

COE CST Fifth Annual Technical Meeting

Task 293. Reduced Order Non-Linear Structural Model

Donghyeon Ryu, Ph.D.

*October 27-28, 2015
Arlington, VA*



Agenda

- Team Members
- Task Description
- Schedule
- Goals
- Results
- Conclusions and Future Work

Team Members

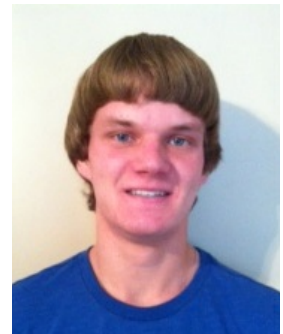

- **Principal Investigators:**

- Donghyeon Ryu, Ph.D., Assistant Professor of Mechanical Engineering, NMT
- Keith Miller, Ph.D., Adjunct Professor of Mechanical Engineering, NMT

- **Student:**

- Mr. Kevin Vedera, BS MENG (May 2016)

- **FAA Technical Monitor:**

- Mr. Nickolas Demidovich

- **Lead Organization: New Mexico Tech**

- Research Partner: Sandia National Laboratories
- Industry Partners: United Launch Alliance, Ball Aerospace

Task Description

- Research Motivation:
 - Finite element analysis of whole structures requires a computational model with large degree of freedoms (DOF), which increases computational costs.
- Methodology:
 - Substructuring: a part of structure (or substructure A) is modeled with reduced DOFs and model of rest part (or substructure B) is experimentally derived to enhance accuracy.

Schedule

- Spring and Summer 2015
 - Testing substructures of the beam specimen to extract modal parameters of the substructures
 - Validation of testing methodology and MATLAB modal parameter extraction code by comparing the experimental and COMSOL FEA models
- Fall 2015
 - Development of MATLAB substructuring using the updated Craig-Bampton method

Goals

- Goals of Specific Task
 - Development of substructuring MATLAB code to combine experimentally derived modal substructure components to reduced-order finite element models of substructures
- Relevance to Commercial Space Industry
 - This methodology will aid in determining the performance and safety margins of commercial space vehicles

Results: Validation of GMAP Code

- Global Modal Analysis Package (GMAP) algorithm was used in MATLAB modal analysis code
 - GMAP code was validated for testing the whole beam

Whole Beam Natural Frequency [Hz]

Mode	Experimental	Truth model
1	34.0	33.0
2	65.8	65.5
3	93.8	92.9
4	146.6	149.9
5	185.4	183.5

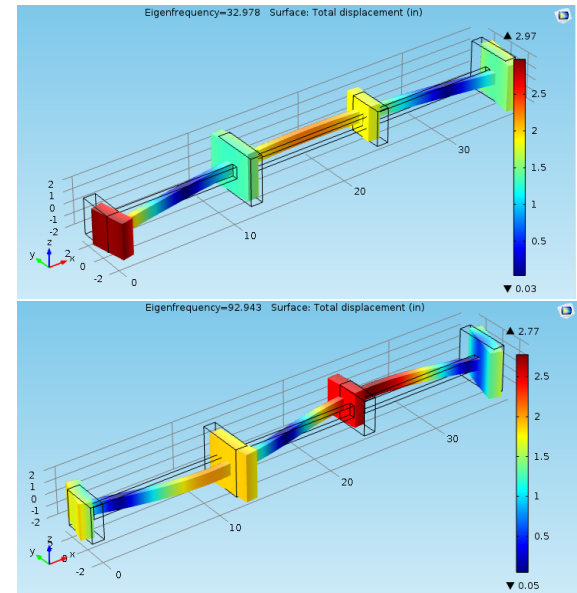

Results: Testing Substructure

- Modal Analysis of Substructures:
 - Reduced-order COMSOL beam model analysis of substructure A: missing one mode and limited accuracy
 - Experimental modal analysis of substructure B: matching with truth computational model

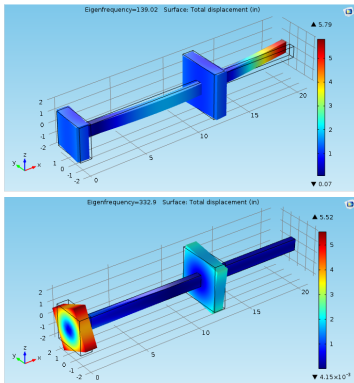

Beam model of substructure A

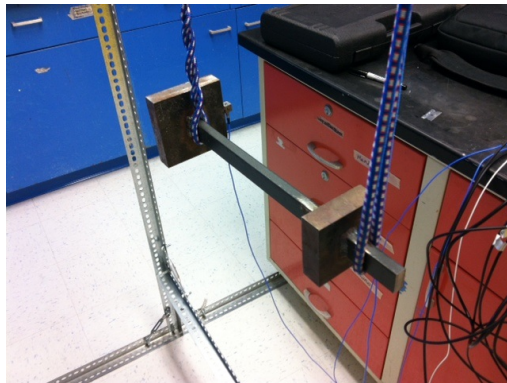

Experimental modal analysis of substructure B

Natural Frequency [Hz]		
Mode	Substructure A (Reduced Order)	Substructure B (Experimental)
1	132	239
2	265	323
3	333	582
4	681	851
5	N/A	1198

Results: Substructuring

- Validation of Updated Craig-Bampton Method:
 - Combining mass and stiffness matrices of substructure A and B beam model COMSOL analysis

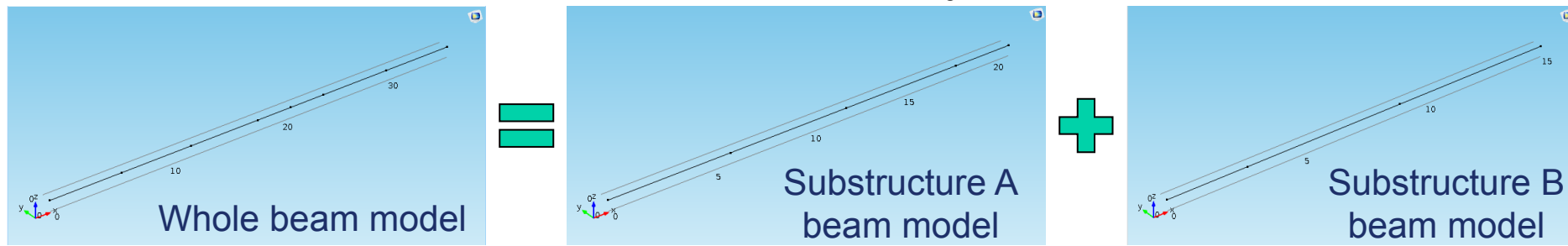

Whole Beam Natural Frequency [Hz]

Mode	Experimental	Truth model	Beam model	Substructuring
1	34.0	33.0	36.0	251.3
2	65.8	65.5	161.9	441.3
3	93.8	92.9	244.3	476.2
4	146.6	149.9	271.9	538.8
5	185.4	183.5	491.7	561.4

Conclusions and Future Work

- **Summary:**
 - Experimental method was improved to yield reliable modal analysis using GMAP MATLAB code.
 - Modal parameters of substructures were acquired using COMSOL beam model and experimentation.
 - The developed MATLAB substructuring code was tested with COMSOL beam model substructures.
- **Next Step:**
 - Improvement of accuracy of the MATLAB substructuring code to substructure reduced-order computational model and experimentally derived model

TASK 293. Reduced Order Non-Linear Structural Model

SUBSTRUCTURING

PROJECT AT-A-GLANCE

- UNIVERSITY: New Mexico Tech
- PRINCIPAL INVESTIGATORS: Dr. Donghyeon Ryu and Dr. Keith Miller
- STUDENT: Mr. Kevin Vedera
- FAA TECHNICAL MONITOR: Mr. Nickols Demidovich

RELEVANCE TO COMMERCIAL SPACE INDUSTRY

- The structural integrity of commercial launch platforms must be assessed for each mission, i.e. safety certification or recertification. A significant amount of structural response data must be collected in order to state confidence bounds on the computed safety margins. Experimental data will very likely need to be supplemented with data generated by numerical simulations of the structural response of the launch platforms to the anticipated flight environments. Efficient, cost-effective methods for generating non-linear structural models of CST platforms will result from this effort.

STATEMENT OF WORK

- Solicit Industrial Working Group feedback to guide implementation of system computational assembly methods.
- Generate non-proprietary code to extract relevant structural features from experimental test data i.e. modal extraction software using rational fractional polynomials (RFP)
- Provide Matlab™ scripts for combining finite element modelled components with experimentally defined (modal) components in structural assemblies.
- Provide help to commercial companies desiring to use modal extraction an assembly codes.

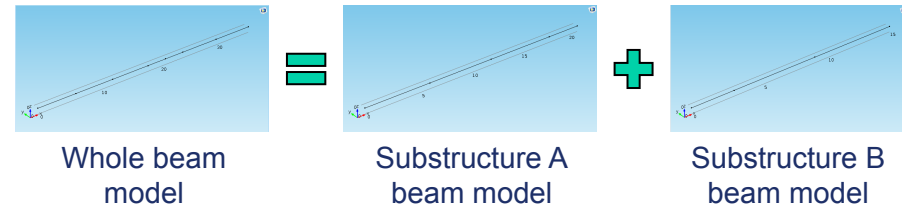
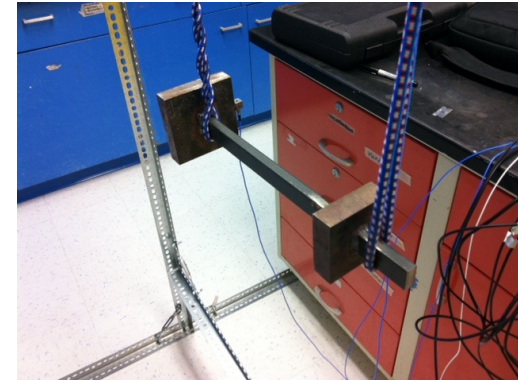
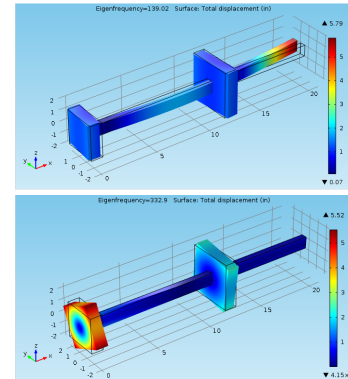

STATUS

- Experimental method was improved to yield reliable modal analysis using GMAP MATLAB code.
- Modal parameters of substructures were acquired using COMSOL beam model and experimentation.
- The developed MATLAB substructuring code was tested with COMSOL beam model substructures.

FUTURE WORK

- Improvement of accuracy of the MATAB substructuring code to substructure reduced-order computational model and experimentally derived model