

# COE CST Eleventh Annual Technical Meeting

## TASK 311. Robust and Low-Cost LED Absorption Sensor for Spacecraft Early Warning Fire Systems

PI & Co-I: Dr. Subith Vasu,  
Dr. Anthony C. Terracciano

Students: Chelsea Kincaid, Garrett Mastantuono  
(Veteran), Zachary Rogers, Abbey Havel, Andrew  
DeRusha, Hamil Patel, Nick Sally, Justin Urso



Center of Excellence for  
Commercial Space Transportation



# Agenda

- Team Members
- Task Description
- Schedule
- Goals
- Results
- Conclusions and Future Work



# Team Members

**PI: Dr. Subith Vasu**

University of Central Florida



Co-I Dr. Anthony  
C. Terracciano



Nick  
Sally

Abbey  
Havel

Chelsea  
Kincaid

Andrew  
DeRusha

Hamil  
Patel

Zachary  
Rogers

2022 Defense and Commercial Sensing Presenters

**Students 2021-2022 who  
got internships**

- Giovanni Wancelotti
- Farid Abuid (Veteran)



**Justin Urso**



**Garrett Mastantuono  
(Veteran)**

## Sponsoring Organizations



# Task Description

- Develop a device which quantifies the presence of gases which indicate a fire or malfunction on spacecraft

- LEDs are used as sources for absorption spectroscopy

$$T_\lambda = \left( \frac{I_\lambda}{I_{\lambda,0}} \right) = \exp(-\alpha_{\lambda,i} \cdot \chi_i \cdot L)$$

$T_\lambda$  - Spectral Transmittance

$I_{\lambda,0}$  - Source Intensity

$I_\lambda$  - Transmitted spectral intensity of electromagnetic radiation

$\alpha_{\lambda,i}$  - absorption coefficient of  $i^{\text{th}}$  species

$\chi_i$  - molar fraction of  $i^{\text{th}}$  species

$L$  - Path variable

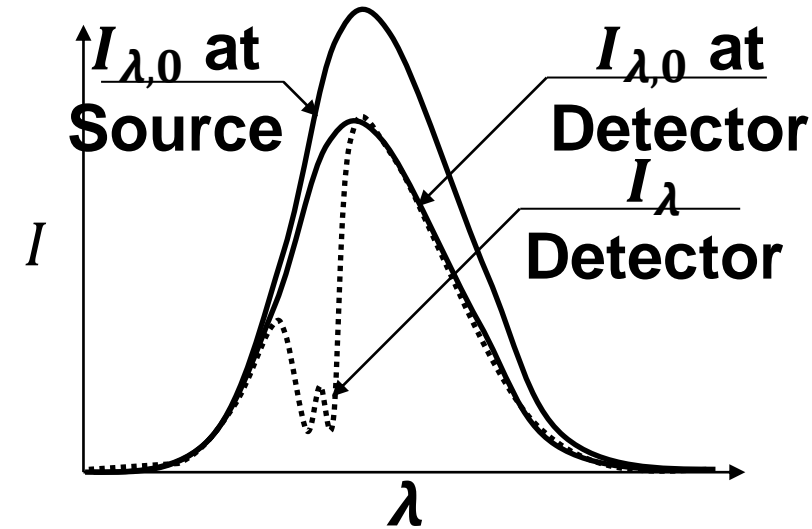
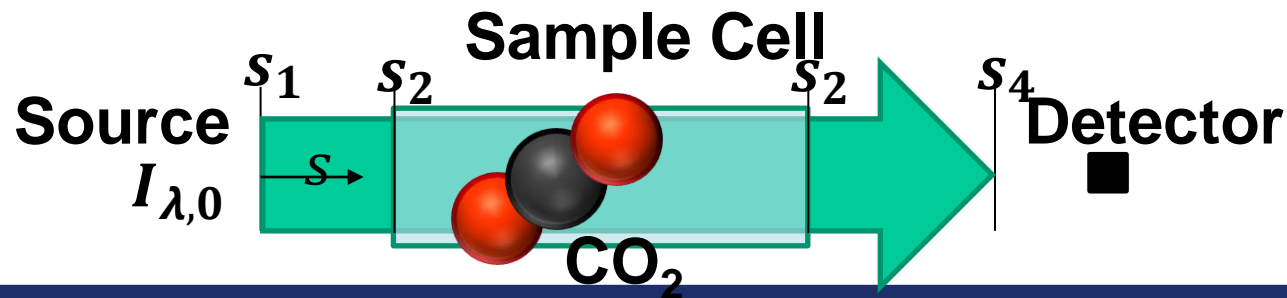

# Schedule

- 2016 – Laboratory proof of concept
- 2017-2020 – Demonstration of functionality in a high-altitude balloon flight, system downsizing
- 2021 –now, Downsizing
  - 3d Printing of optomechanical components/enclosure
  - Task built electronics (analog, power, & data processing)
  - Power & computational need reduction
  - Optics validation
- 2022 Forward, testing (ground and sounding rocket), commercial adoption



# Goals

- **Spacecraft cabin air is confined aboard spacecraft and toxic gases may accumulate**
- **Toxic gas sources include**
  - **Human activity**
  - **Astroculture**
    - (plant hormones, pollen, *etc.*)
  - **System malfunctions**
- **Rapid detection and localization is necessary to ensure safety of crew & experiments**
- **Commercial space needs “standard solutions”**

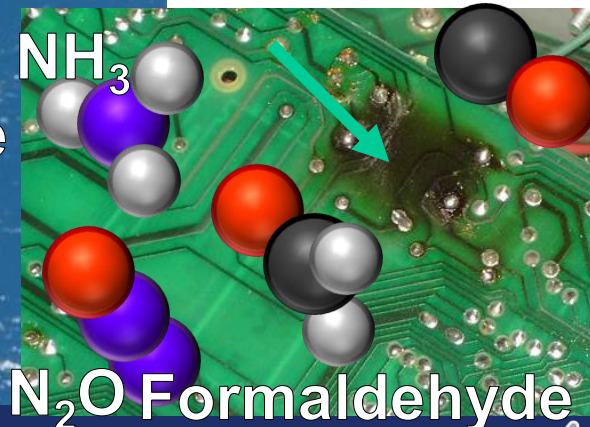
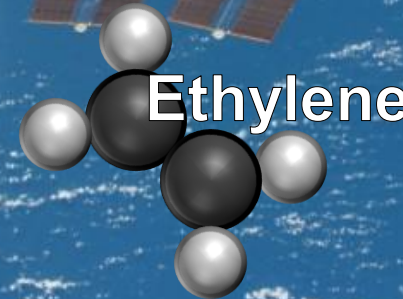
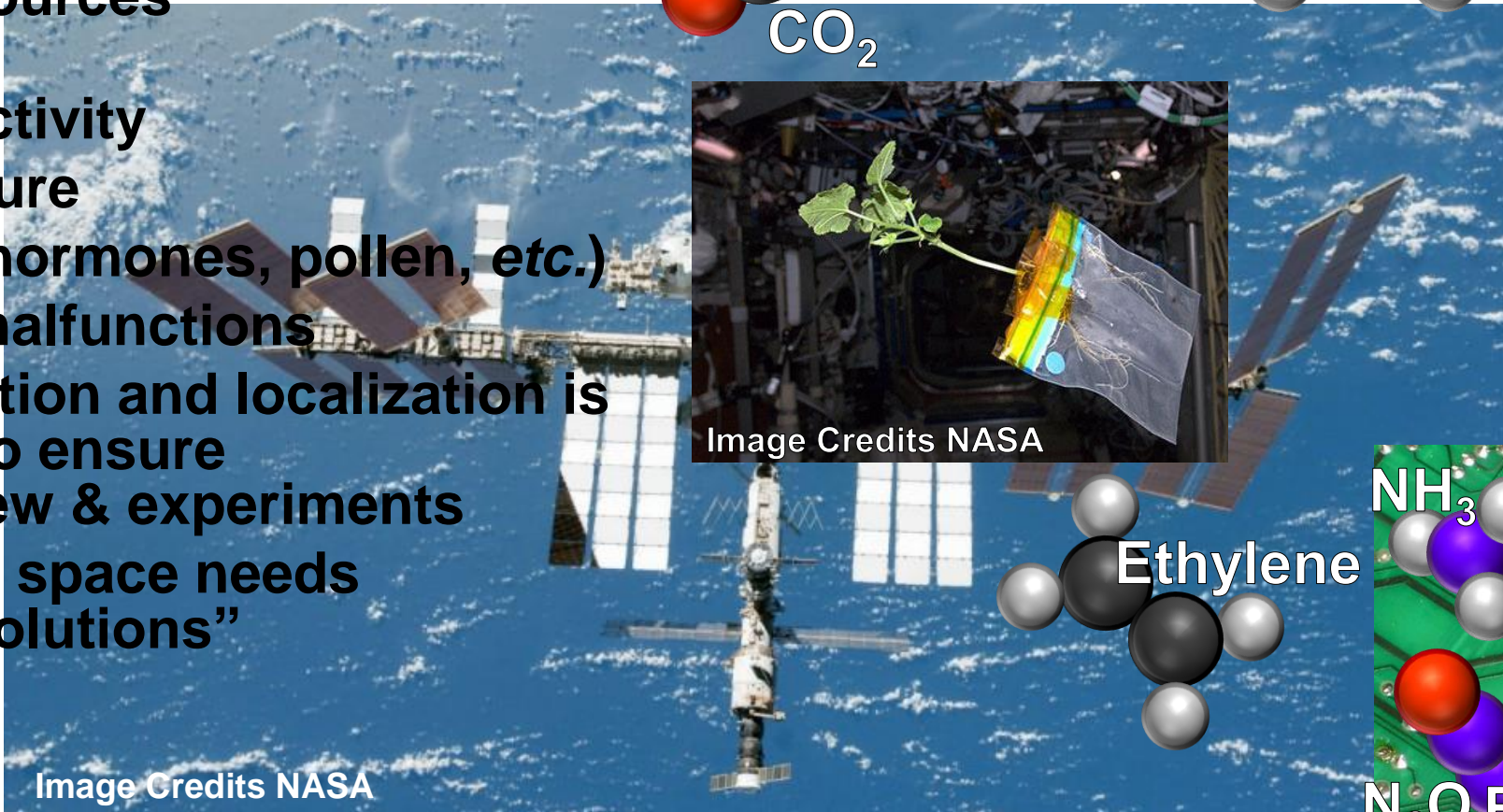
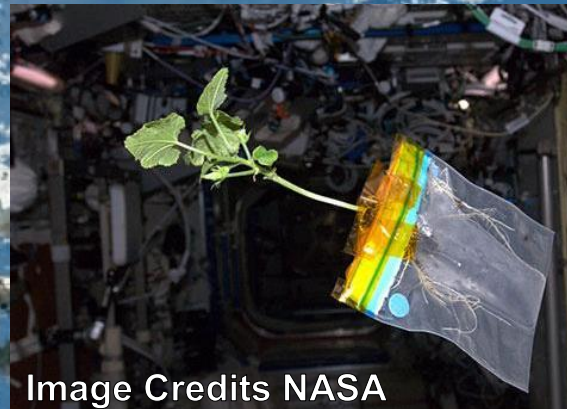

# Results

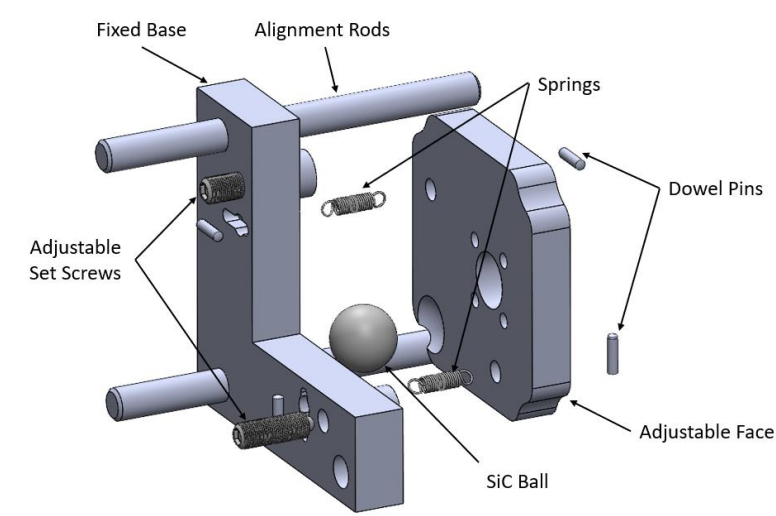
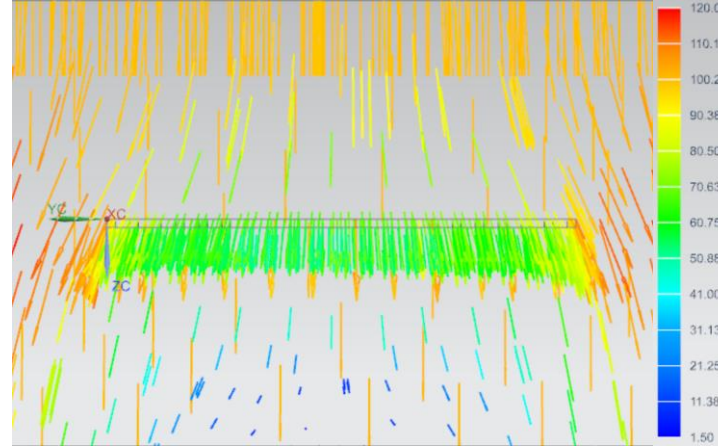
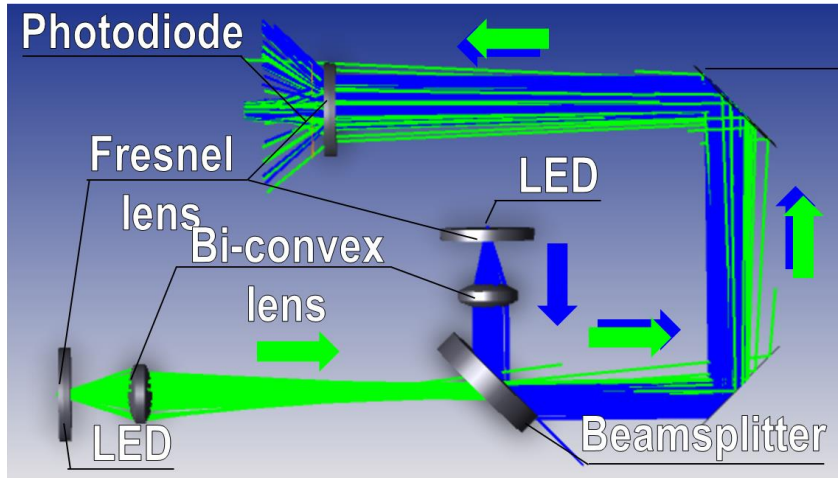

1. “Gaseous Absorption Detection for Space Applications (GADSA): An LED-Based Early Fire Warning System”
2. “Rapid Indexable Positioning System (RIPS) for 3D printed aerospace electro-optics”
3. “High efficiency thermoelectric optoelectronic component temperature regulation”
4. “Embedded systems development for spacecraft MIR hazardous gas detector”
5. “3D Printed Optomechanical Positioners for Aerospace Metrological Instruments”

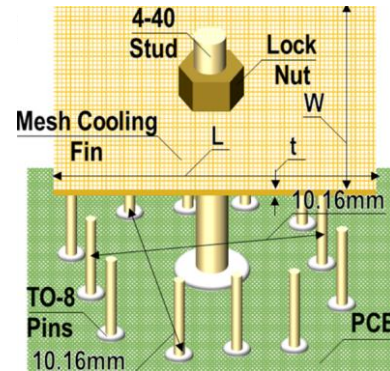

Reserved Space for Electrical Components

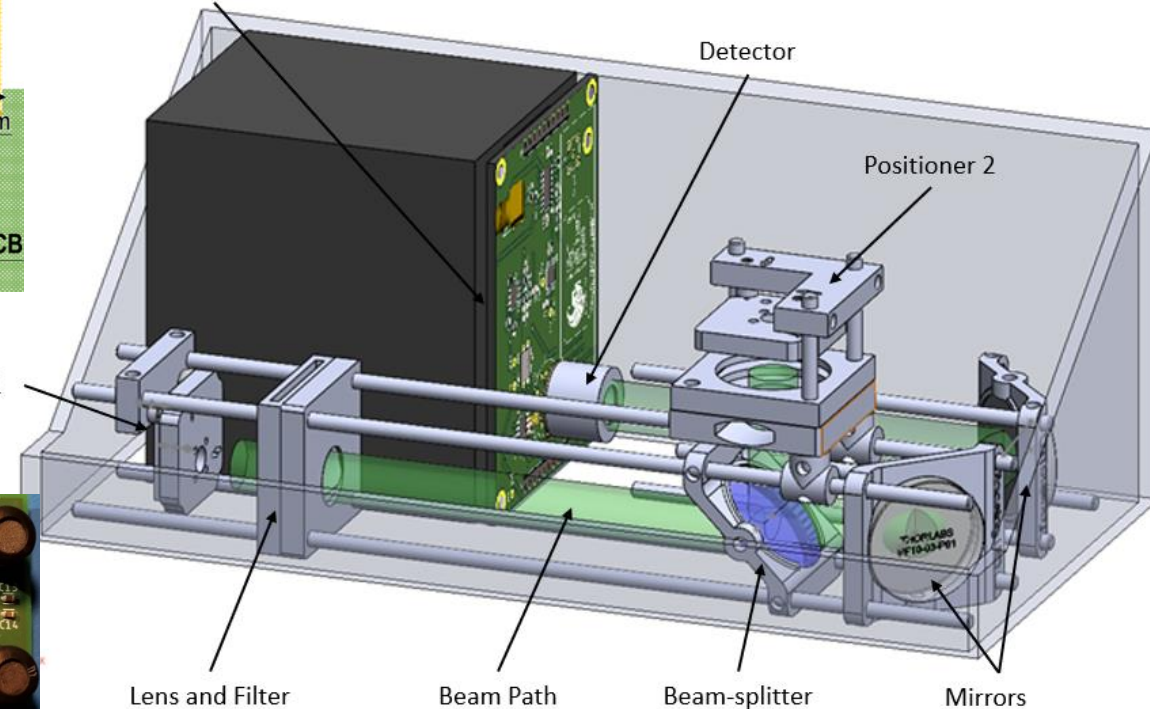
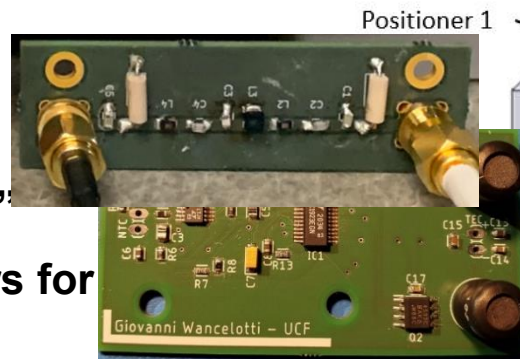

# Publications, Presentations, Awards, & Recognitions

## PRESENTATIONS 2021-2022

1. “Gaseous Absorption Detection for Space Applications (GADSA): An LED-Based Early Fire Warning System”, Abbey Havel, Andrew DeRusha, Hamil Patel, Chelsea Kincaid, Giovanni Wancelotti, Zachary Rogers, Nickolas Demidovich, Anthony C. Terracciano, Subith S. Vasu, *SPIE 2022 Defense + Commercial Sensing*
2. “Rapid Indexable Positioning System (RIPS) for 3D printed aerospace electro-optics”, Hamil Patel, Andrew M. DeRusha, Abbey Havel, Giovanni D. Wancelotti, Zachary L. Rogers, Chelsea M. Kincaid, Justin J. Urso, Nickolas Demidovich, Anthony C. Terracciano, and Subith S. Vasu, *SPIE 2022 Defense + Commercial Sensing*
3. “High efficiency thermoelectric optoelectronic component temperature regulation”, Zachary L. Rogers, Chelsea M. Kincaid, Hamil Patel, Andrew M. DeRusha, Abbey Havel, Giovanni D. Wancelotti, Garrett T. Mastantuono, Justin J. Urso, James Wilson, Nickolas Demidovich, Anthony C. Terracciano, Subith S. Vasu, *SPIE 2022 Defense + Commercial Sensing*
4. “Embedded systems development for spacecraft MIR hazardous gas detector”, Chelsea Kincaid, Giovanni Wancelotti, Abbey Havel, Andrew DeRusha, Hamil Patel, Zachary Rogers, Nicholas A. Sally, Nickolas Demidovich, Justin Urso, Anthony C. Terracciano, Subith S. Vasu, *SPIE 2022 Defense + Commercial Sensing*
5. “3D Printed Optomechanical Positioners for Aerospace Metrological Instruments”, Andrew DeRusha, Hamil Patel, Abbey Havel, Giovanni Wancelotti, Zachary Rogers, Chelsea Kincaid, Nickolas Demidovich, Justin Urso, Anthony C. Terracciano, Subith S. Vasu, *SPIE 2022 Defense + Commercial Sensing*





# Conclusions and Future Work

- Several students (traditional, veteran, & underrepresented in STEM) have contributed to developing aerospace hardware
- CSWaP of sensor was reduced,  $<4.5W$ ,  $\sim 3kg$ ,  $\sim 2.1 L$
- Future tests include lab ground testing
  - Shake Table, environmental chamber with fill gas mixtures, temperature & pressure
- Subsequent sounding rocket testing

