

Acquisition and allocation of resources in response to elevated CO₂ and nitrogen
fertilization in two perennial C₃ grasses

Hannah Abigail Kinmonth-Schultz

A thesis submitted in partial fulfillment of the
requirements for the degree of

Master of Science

University of Washington

2009

Program Authorized to Offer Degree:
College of Forest Resources

University of Washington
Graduate School

This is to certify that I have examined this copy of a master's thesis by

Hannah Abigail Kinmonth-Schultz

and have found that it is complete and satisfactory in all respects,
and that any and all revisions required by the final
examining committee have been made.

Committee Members:

Soo-Hyung Kim

Kern Ewing

Thomas Hinckley

Date: _____

In presenting this thesis in partial fulfillment of the requirements for a master's degree at the University of Washington, I agree that the Library shall make its copies freely available for inspection. I further agree that extensive copying of this thesis is allowable only for scholarly purposes, consistent with "fair use" as prescribed in the U.S. Copyright Law. Any other reproduction for any purposes or by any means shall not be allowed without my written permission.

Signature _____

Date _____

University of Washington

Abstract

Acquisition and allocation of resources in response to elevated CO₂ and nitrogen fertilization in two perennial C₃ grasses

Hannah Abigail Kinmonth-Schultz

Chairperson of the Supervisory Committee:
Assistant Professor Soo-Hyung Kim
College of Forest Resources

Atmospheric concentrations of carbon dioxide (CO₂) have increased over the last century, likely due to human activity, and will likely continue to increase. Plants will respond to increased CO₂ by increased rates of photosynthesis, biomass, and carbon stored in plant tissue; however, the response may differ between plant species and functional groups. Therefore, composition of communities may be altered. Fast growing invasive plants may be best suited to take advantage of the increase in CO₂.

The effect of CO₂ on plant growth must also be considered in conjunction with other human mediated resource changes. Nitrogen is of particular interest because it is often a component of run-off from urban and agricultural areas into natural lands, as well as being a component of wet and dry atmospheric deposition; it facilitates invasive plant establishment; and plant growth is impacted by the ratio of carbon to nitrogen in plant tissue. Here we describe chambers that were built to elevate CO₂ and the results of a study in which two plant species were subjected to elevated CO₂ and nitrogen.

Phalaris arundinacea is a common invader of wetlands throughout North America, while *Glyceria striata* is a native species that has been found to suppress

germination of *P. arundinacea* seedlings. Both are rhizomatous, C₃, perennial grasses. These species were subjected to either ambient or elevated CO₂ (~320 ppm above ambient), and two nitrogen treatments – full strength Hoagland’s solution or a modified solution containing 1/8th the nitrogen components, over two repetitions of a closed-top chamber experiment in the Douglas Research Conservatory, at the University of Washington Botanic Gardens, Seattle, WA, USA.

The chambers were effective in maintaining elevated CO₂ levels, however improvements to their design are discussed. While nitrogen was the strongest contributor to differences in growth in both species, CO₂ contributed to an increase in aboveground biomass, primarily in stem and leaf biomass. The CO₂ effect was enhanced in the high nitrogen pots while the increase was more pronounced for *G. striata*. For both species elevated CO₂ led to an increase in root biomass across nitrogen treatments, and for *P. arundinacea*, a decrease in allocation to rhizomes in the high nitrogen pots. Elevated CO₂ led to a decrease in specific leaf area for *P. arundinacea*.

For *P. arundinacea* the carbon-to-nitrogen ratio increased in the low nitrogen pots, both because of an increase in carbon, and because of a decrease in nitrogen. The same pattern occurred for *G. striata*; however, this was due only to a decrease in nitrogen. *P. arundinacea* increased its fructan-to-carbon ratio in the low nitrogen pots, with an even higher increase under elevated CO₂. Most responses to CO₂ occurred during the first experimental repetition, which had higher light levels than the second.

We conclude that elevated CO₂ likely increased the competitive ability both species, but for somewhat different reasons. It may increase the competitive ability of *P. arundinacea* by increasing aboveground growth in high nitrogen environments. *Phalaris arundinacea* responds to low nitrogen by increasing carbon allocation to its rhizomes, primarily to non-structural carbohydrates such as fructans. Elevated CO₂ magnifies this trend. Elevated CO₂ may also enhance the competitive ability of *G. striata*, and *G. striata* does not accumulate carbon, but rather stores nitrogen in its rhizomes when nitrogen is available.

TABLE OF CONTENTS

	Page
List of Figures	iii
List of Tables	iv
Chapter 1. Introduction	1
1.1 Overview of Chambers and Description of Need.....	2
1.2 Chamber Design	3
1.2.1 Construction.....	3
1.2.2 Monitoring	7
1.3 Results and Discussion	8
1.3.1 CO ₂ Elevation	8
1.3.2 Temperature	13
1.3.3 Plant Response.....	15
1.3.4 Overview of Cost.....	15
1.3.5 Design Inadequacies	15
1.3.6 Conclusions.....	18
Chapter 2. Response of <i>Phalaris arundinacea</i> and <i>Glyceria striata</i> to CO ₂ and Nitrogen.....	19
2.1 Introduction.....	19
2.1.1 Effects of Elevated CO ₂ on Plant Growth	21
2.1.2 Effects of CO ₂ in Conjunction with Nitrogen.....	24
2.1.3 Introduction of Species Used for Experiment	26
2.2 Materials and Methods	28
2.2.1 Plant Materials and Treatments	28
2.2.2 Chamber Construction, CO ₂ Elevation, and Monitoring.....	31
2.2.3 Measurement of Morphological Parameters.....	33
2.2.4 Determination of Water Use.....	35
2.2.5 Determination of Photosynthetic Rate (A), Rubisco	

Functioning (V_{cmax}), and Stomatal Conductance (g_s)	35
2.2.6 Determination of Fructan, Carbon, and Nitrogen Content in Rhizomes.....	36
2.2.7 Experimental Design and Statistical Analysis	38
2.3 Results.....	40
2.3.1 CO ₂ Elevation, Temperature, and Light Levels.....	40
2.3.2 Absolute Biomass	43
2.3.3 Biomass Allocation.....	48
2.3.4 Tiller Number, Leaf Area, Specific Leaf Area	51
2.3.5 Water Use	53
2.3.6 Photosynthetic Rate (A), Rubisco Functioning (V_{cmax}), and Stomatal Conductance (g_s).....	54
2.3.7 Fructan, Carbon, and Nitrogen Content in Rhizomes.....	56
2.4 Discussion.....	59
2.4.1 CO ₂ Elevation, Temperature, and Light Levels.....	59
2.4.2 Morphological Parameters.....	61
2.4.3 Water Use	66
2.4.4 Photosynthesis (A) and Rubisco Functioning (V_{cmax})	66
2.4.5 Fructan, Carbon, and Nitrogen Content in Rhizomes.....	68
2.4.6 Synthesis	72
2.5 Implications	75
2.5.1 <i>Phalaris arundinacea</i>	75
2.5.2 <i>Glyceria striata</i>	78
2.6 Suggestions for Future Study.....	79
Literature Cited.....	81
Bibliography	90
Appendix A: List of Data Transformations	103

LIST OF FIGURES

Figure Number	Page
1.1 Schematic of Chamber.....	6
1.2 Mean Diurnal CO ₂ Levels	9
1.3 Mean Diurnal Temperatures	14
1.4 Chamber Positions in Greenhouse.....	14
2.1 Potting Method and Chambers	30
2.2 Mean Diurnal CO ₂ Levels	41
2.3 Mean Diurnal Temperatures	42
2.4 Mean Diurnal Light Levels.....	43
2.5 Whole-plant, Leaf, Stem, Rhizome, and Root Biomass for <i>Phalaris arundinacea</i>	44
2.6 Whole-plant, Leaf, Stem, Rhizome, and Root Biomass for <i>Glyceria striata</i>	47
2.7 Biomass Allocation for <i>Phalaris arundinacea</i> and <i>Glyceria striata</i>	50
2.8 Carbon and Nitrogen Content in <i>Phalaris arundinacea</i> and <i>Glyceria striata</i>	57
2.9 Carbon and Fructan Content in <i>Phalaris arundinacea</i>	58

LIST OF TABLES

Table Number	Page
1.1 Hourly Mean CO ₂ Levels	12
1.2 Summary of Costs for Chamber Construction.....	16
2.1 <i>Phalaris arundinacea</i> Data Points for Biomass, Tiller Number, SLA Water Use, and Leaf Area	45
2.2 <i>Glyceria striata</i> Data Points for Biomass, Tiller Number, SLA Water Use, and Leaf Area	46
2.3 Data Points for Photosynthesis (A), Stomatal Conductance (g _s), and V _{cmax} of Rubisco.....	55

ACKNOWLEDGEMENTS

I would like to thank my advisor Dr. Soo-Hyung Kim. Through his patient tutelage, I have learned much about ecophysiology and experimental design.

I would also like to thank the members of my committee, Dr. Kern Ewing and Dr. Thomas Hinckley, for their early suggestions, their support and advice throughout, and their thoughtful comments on my manuscript.

This project would have been much more difficult had it not been for my lab mates, Lisa Ceicko, Nicole Hackman, Jeffery Richardson, Emily Palm, and Brandon Neuhaus, who provided valuable feedback for early iterations of my project and chamber design. I also thank them and later additions to our lab, Nathaniel Hough-Snee, Lloyd Nackley, and Chessa Goss for their comments on my manuscript.

I must also again thank several of my lab mates and Laura Blume, Ben Peterson, Michael Hannam, and Lauren Urgenson for help in chamber construction. I would not have been able to do it without them.

I also extend my gratitude to my undergraduate assistants, Marianne Powell and Kimberly Anne Jones, who worked diligently and independently to assist me on aspects of this project.

Finally, I thank my husband, Nicholas Schultz, for his support during difficult portions of the past two years and his encouragement throughout. He is my cheerleader.

CHAPTER 1. INTRODUCTION

Human activities are altering global plant resource availability at an unprecedented rate. In 1997, it was estimated that each year humans double the natural rate of nitrogen fixation by burning fossil fuels that release long-stored nitrogen, planting nitrogen fixing crops, and fixing atmospheric nitrogen for fertilizer through industrial processing (Vitousek et al. 1997). Water quality and timing of water cycles have changed over the past decades as humans manage rivers and draw from groundwater systems for irrigation and municipal uses (Both & Jackson 1997). Most recently, increases in atmospheric carbon dioxide (CO₂) have come to the attention of both scientists and the general public. The 2007 report by the Intergovernmental Panel on Climate Change (IPCC) recognizes that CO₂ has increased since the onset of the industrial age, the causes of the increase are largely due to human activity, and the increase will likely continue (IPCC 2007).

Each of these factors alone, together, or in conjunction with factors such as regional temperature shifts have the propensity to alter plant growth. While the direction of some alterations may be predictable, i.e. low soil nutrient availability increases biomass allocation to roots, the extent or degree of change may differ among species or plant functional groups. This, in turn, may alter the way in which plants interact both with other plant species and with components of their environment as a whole (Bradley & Pregitzer 2007).

In this work, I focus on the effects of two resources, CO₂ and nitrogen. In the first chapter, I discuss the first iteration of a chamber design that has been used to manipulate CO₂. In subsequent sections I describe the results of a study in which plants were subjected to different combinations of CO₂ and nitrogen fertilization.

1.1 OVERVIEW OF CHAMBERS AND DESCRIPTION OF NEED

Earth's atmospheric carbon dioxide (CO₂) concentrations are increasing due to anthropogenic activity (IPCC 2007). Often, the focus on CO₂ is as a greenhouse gas and as a contributor to climate change; however, we now understand that the increase in CO₂ over the last 100 years has likely altered plant growth (Garcia-Amorena et al. 2006). While such observations have implications for plant growth alone, the ways in which plants respond to elevated CO₂ may have larger impacts as well. For example, plant assemblages play integral roles in a region's climate (Callaghan et al. 2004). Study of plant response to CO₂ is therefore necessary to help us predict and, if possible, to mitigate the effects of climate change. However, methods used to elevate CO₂ are often expensive, limiting the number of labs that are able to perform such studies. Here we provide a design for an inexpensive, easily built chamber by which CO₂ may be elevated. We then proceed to discuss its effectiveness and limitations, and propose suggestions for subsequent iterations of the design.

In addition to the need for relatively inexpensive construction and operating costs, we required chambers that were 1) tall enough to hold plants that can reach 150

cm in the wild, and 2) large enough to hold multiple replicates of large pots, enabling us to test the effects of CO₂ on communities of plants as well as on individuals.

Further, to provide flexibility in subsequent experiments, we proposed that the chambers be able to convert from a closed- to open-top configuration and be able to be utilized both indoors and out. This last objective, then, required that the chambers be light, portable, and easy to disassemble and reassemble.

The result was a chamber in which CO₂ could be enriched, and that was transportable and convertible. The chamber can be used in a closed or open-topped configuration and either rests on a wheeled base for use indoors, or can be removed from its base and placed over outside vegetation. Fresh air, which can be enriched with CO₂, is forced through a series of ductwork and plumbing via an inline fan and is delivered to the chamber through holes in the frame. The need to keep costs low as well as the desire that the chambers be portable meant that our design did not include a refrigeration system nor did it include automated control of CO₂ levels; however, this meant that both CO₂ and temperature tracked a diurnal pattern similar to what occurs naturally (George et al. 2007).

1.2 CHAMBER DESIGN

1.2.1 Construction

The chambers are composed of three frames: an internal PVC-pipe frame, which

supports the chambers, a wooden top frame, which supports the top of the chambers, and a wooden base frame, which surrounds the bottom of the chamber (fig. 1.1). The PVC pipe frame is assembled from 3.18 cm internal diameter, (1.25 in), 160 PSi PVC pipe. The pipes comprising the base and the top of this frame are 90.5 cm in length, and those at the corners are 188.5 cm. These are assembled using eight 90° three-way PVC joints (US Plastic Corp., Lima, OH, USA), such that the outside of the frame measures 100 x 100 x 200 cm tall. A PVC t-joint is inserted into the center rear of the frame base to connect the chamber frame to the plumbing, and 0.64 cm holes are drilled every 15 cm around the base and 120 cm up each corner pipe to bring air into the chamber. The top of the chamber is made of two 0.64 cm thick PVC sheets measuring 107 cm x 53.4 cm, which rest on the wooden top frame made of nine 2.54 x 10.16 cm (1x4 in) boards. For this frame, four boards are cut with 45° angles at each end, such that the boards are 103 cm on the outside edge and 91 cm on the inside. These boards are joined at the corners and held together using 90°-angled brackets. A fifth board, 91 cm in length, is attached across the center of the frame made by the first four boards by four straight brackets (two on each end), to serve as a central support for the PVC sheets. The last four boards are attached perpendicularly to the outside of frame, so that the final dimensions of the chamber top are 107 x 107 cm. Quarter-round molding is nailed around the outside edge of the frame to create a cavity into which the two PVC sheets rest.

Around the base of the PVC-pipe frame is attached the wooden base frame made of 2.54 x 10.16 cm (1x4 in) boards, and measuring 107 x 107 cm. These are

oriented so that the 10.16 cm edge runs parallel to the vertically oriented pipes at the corner of the PVC-pipe frame, and is attached to the PVC-pipe frame using four 10.16 cm carriage bolts placed through holes drilled through the board and PVC pipe base (two each on opposite sides). The sides of the chamber are covered with 0.005 mm clear Mylar® polyester sheeting (ePlastics, San Diego, CA, USA), attached to the wooden top and base frames using Velcro®. The Mylar® sheets are sealed at three of the four corners using clear packaging tape, and with Velcro® at the fourth to allow access into the chamber. The total luminous transmittance of the Mylar® is 88.00%, and oxygen diffusion over a 24 hr period is 4 cc/254 cm² (Dupont 2009a).

The chamber rests on a wheeled base that is comprised of six 5.08 x 5.08 cm (2x2 in) boards. Two are cut to 110 cm, and four are cut to 102.4 cm. The two 110 cm boards and two of the 102.4 cm boards are used to make a frame with the remaining two attached inside the frame for central support. The plywood itself is 110 x 110 cm. The four wheels are 10 cm castors, whose threaded ends are put through holes drilled through the plywood. Large, 5.08 cm washers placed above and below the plywood, where each castor is attached, add support.

Fresh air is brought to the chamber through a series of ductwork and piping. Flexible dryer ducting (15.24 x 609.6 cm, 4 x 240 in) is attached near the inlet of the green house and run to a variable speed inline fan (Model FR, Fantech, Sarasota, FL, USA). A 15.24 to 10.16 cm bushing (6 in to 4 in) connects the fan to a 10.16 cm (4 in) PVC-pipe T-joint, which distributes the air to two chambers. From the t-joint to each of the two chambers, runs a 10.16 cm (4 in) aluminum duct attached to a 10.16 cm (4 in)

PVC pipe that is 60.96 cm in length. A 10.16 to 10.16 cm (4 to 4 in) bushing connects the aluminum duct to the pipe. To this pipe, 0.64 (1/4 in) Teflon® tubing is connected to bring CO₂ to the chamber. Two bushings, 10.16 to 3.81 cm (4 to 1.5 in) and 3.81 to 3.18 cm (1.5 to 1.25 in), and a 15 cm length of 3.18 cm internal diameter, (1.25 in), 160 PSi PVC pipe connect the plumbing to the t-joint at the base of the chamber. A 10 cm gap is cut into the wooden base frame of the chamber to accommodate this connection. The flow rate of CO₂ into the chambers was controlled using bubble flow meters (FL-2000, Omega, Stanford, CT, USA). The fans ran continuously at maximum speed replacing the air in the chambers an estimated 6.68 times per minute.

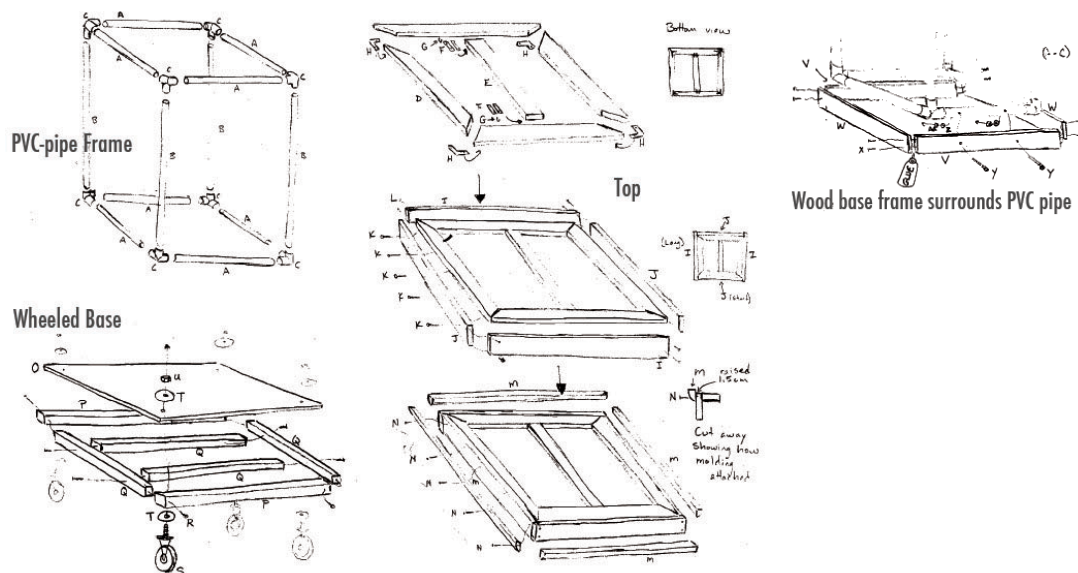

Figure 1.1 Schematic of chamber used to elevated carbon dioxide (CO₂)

1.2.2 Monitoring

Chamber CO₂ concentrations were monitored by collecting air from each chamber using 0.64 cm (0.25 in) clear vinyl tubing placed 50 cm into the chambers from the top and connected to an infrared gas analyzer (CIRAS, PP Systems International, Inc., Amesbury, MA, USA). The elevated chambers were connected to the reference port of CIRAS, while the ambient chambers were connected to the analogue port. Because CIRAS is capable of reading only two samples at a time (the reference and analogue), the collecting tubes from the elevated CO₂ chambers were first joined using plastic t-joints then connected to CIRAS, such that CIRAS read the average CO₂ concentration for the two chambers. The same was done for the ambient CO₂ chambers. The concentrations within the individual chambers were checked weekly to ensure similar concentrations within CO₂ treatments. CIRAS was calibrated at 0 and 700 ppm of CO₂ prior to the beginning of the experiment, then recalibrated at 700 ppm, first bi-weekly, and then monthly after we found that CIRAS did not deviate by more than 5 ppm over the course of two weeks. All tubing, ducting, and plumbing were cut to ensure equal distances from the source to the chamber.

Temperature in each chamber was monitored using a pair of thermocouples placed 20 and 100 cm from the tops of the chambers. The thermocouple pairs were connected in parallel to provide the average temperature within a chamber, and then run to a datalogger (CR1000, Campbell Scientific, Logan, UT, USA). Light levels outside of the greenhouse were collected using a quantum sensor (SQ-100, Apogee

Instruments, Logan, UT, USA) and recorded in a datalogger (CR10, Campbell Scientific, Logan, UT, USA) (Hackman 2009). Temperature and light were recorded every 15 min and CO₂ every 30 min, and downloaded to a computer bi-weekly.

The results presented below are from two experimental repetitions, a summer run (hereafter repetition 1) beginning on July 7, 2008 and a fall run (hereafter repetition 2) beginning on September 21, 2008 in which the chambers contained growing plants. Each repetition lasted 10 weeks.

1.3 RESULTS AND DISCUSSION

1.3.1 CO₂ Elevation

The levels in both the ambient and elevated CO₂ chambers (hereafter “ambient chamber” and “elevated chamber”) displayed a diurnal pattern similar to that found naturally. There was a daytime drawdown due to carbon uptake by photosynthesis and nightly peaks likely due to respiration. However, the range (or difference) between the mean low and high diurnal CO₂ levels was greater than that of two studies that monitored outdoor sites. One study found the greatest diurnal range over five years to be around 100 ppm while the other saw ranges of around 45 ppm (George et al. 2007; Hackman 2009). Within this experiment, the diurnal range from low to high CO₂ levels differed between the first and second repetitions, as did the minimum and maximum levels CO₂. During repetition 1, the levels in the ambient and elevated chambers,

respectively, ranged from lows of 364.34 ± 3.23 and 689.89 ± 8.31 ppm at 1300 hrs to highs of 485.81 ± 11.63 and 826.99 ± 13.42 ppm at 0600 hrs, for a total range of 121.47 and 124.16 ppm (figure 1.2a, table 1.1). During repetition 2, the levels ranged from lows of 411.28 ± 7.12 and 715.00 ± 12.55 at 1300 hrs to highs of 600.75 ± 65.95 and 905.63 ± 61.93 at 0300 hrs, for a total range of 189.47 and 190.63 ppm for the ambient and elevated CO₂ chambers, respectively.

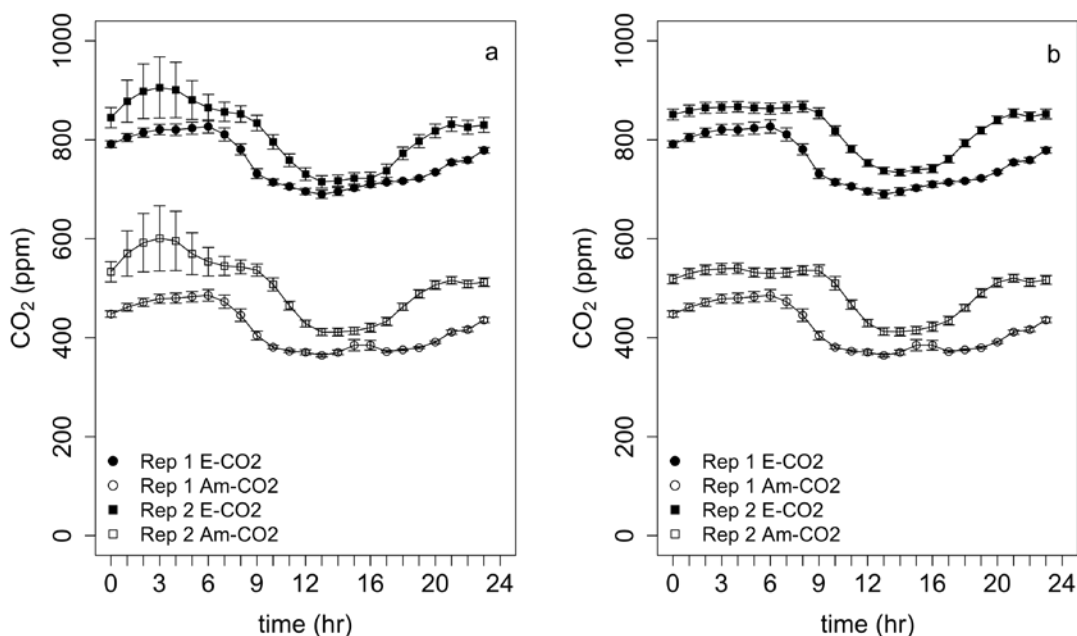

Figure 1.2 Mean diurnal CO₂ levels for the first and second experimental repetitions (Rep 1 & 2) in the elevated (E) and ambient (Am) CO₂ chambers. Figure ‘a’ includes the averages over the 10 weeks of each repetition. Figure ‘b’ excludes the days on which the CO₂ regulator malfunctioned. Error bars are standard error of the mean.

During the repetition 2, the flow meter that regulated CO₂ release from the tank malfunctioned twice, the first time releasing all of the CO₂ in the tank in a matter of hours. The recorded values of CO₂ during this 8 hr period was greater than 1000 ppm, reaching to more than 4000 ppm, with the ambient and elevated chambers differing by

no more than 9 ppm. It is difficult to know whether the measurements for the ambient chambers were accurate on these dates of malfunction as CIRAS is capable only of accurately detecting differences of 700 ppm or less. However, it was the malfunctions that seem to have added to the variability and range of CO₂ levels in both the ambient and elevated chambers in repetition 2. When these six days are removed from the data, the variability and range of repetition 2 becomes similar to repetition 1 – lows of 412.07 ± 8.38 and 733.81 ± 6.33 ppm, highs of 540.30 ± 10.82 and 866.78 ± 10.72 ppm, and ranges of 126.85 and 127.92 ppm for the ambient and elevated chambers, respectively (fig. 1.2b) – although, the hourly mean CO₂ levels are still higher in repetition 2 than they are in repetition 1.

While seasonal changes in day length likely dictated the length of time plants were able to photosynthesize, affecting the length of draw downs in carbon (see discussion of day length in chapter 2), there are multiple possible reasons for the overall higher levels of CO₂ in repetition 2. First, within each repetition the diurnal patterns of CO₂ in the ambient and elevated chambers mirrored each other, having similar patterns of variability and times when peaks and troughs occurred (fig. 2.1, table 1.1). This indicates that the diurnal pattern of CO₂ in the elevated chambers was driven by the diurnal pattern of ambient CO₂ in the greenhouse, and that the addition of CO₂ did not alter the pattern. Therefore, the CO₂ levels in the chambers were driven not only by the plants in the chambers, but also by the other plants in the greenhouse. Because repetition 2 occurred during the fall, plants would have less light by which to photosynthesize and therefore would respire more, contributing to the overall level of

CO₂ being brought into the chambers. Second, similar seasonal patterns would have occurred outside the greenhouse at a landscape level as well (Goudriaan 1987 as cited in Lambers et al. 2006), possibly also contributing to the higher levels of CO₂ in repetition 2. The final possibility is that because a malfunction in the mechanism to elevate CO₂ acted to increase the range and variability of *both* the ambient and elevated chambers, CO₂ leaking from the elevated chambers contributed to the overall level of CO₂ in the greenhouse and therefore also to the levels in the ambient chambers.

Likely, the levels of CO₂ in each chamber were dictated by a combination of factors – the levels of CO₂ in the outlying landscape, the greenhouse, and by a feedback of CO₂ leaking from the elevated chambers. Adjusting the plumbing to draw in air from outside the greenhouse may serve to alleviate both the nightly build up of CO₂ from the greenhouse and the influence of CO₂ from the elevated chambers on the ambient chambers. Seasonal variation in CO₂ due to the outlying landscape will still be a factor, however.

Table 1.1 Hourly mean CO₂ levels, difference between ambient and elevated CO₂ chambers, and ranges from lowest to highest CO₂ level for experimental repetitions 1 and 2. The lowest and highest levels are in bold. Variance is standard error of the mean.

Hour	Repetition 1			Repetition 2		
	Mean Ambient CO ₂	Mean elevated CO ₂	Difference	Mean Ambient CO ₂	Mean elevated CO ₂	Difference
0	447.69 ± 6.48	791.27 ± 6.88	343.58	533.24 ± 20.38	844.71 ± 20.49	311.47
1	461.55 ± 7.64	804.58 ± 8.12	343.03	570.27 ± 45.65	878.00 ± 42.46	307.73
2	471.49 ± 8.33	814.55 ± 9.10	343.07	591.97 ± 58.99	898.06 ± 55.27	306.09
3	478.64 ± 9.44	820.72 ± 10.64	342.08	600.75 ± 65.95	905.63 ± 61.93	304.89
4	479.83 ± 10.35	820.20 ± 11.76	340.37	595.57 ± 60.04	900.60 ± 56.06	305.03
5	482.76 ± 10.64	823.52 ± 12.27	340.76	569.66 ± 42.29	880.46 ± 39.30	310.80
6	485.81 ± 11.63	826.99 ± 13.42	341.18	553.66 ± 28.75	864.71 ± 26.98	311.05
7	472.82 ± 13.32	810.90 ± 13.18	338.07	545.05 ± 19.25	856.59 ± 19.56	311.55
8	445.64 ± 12.70	780.73 ± 10.96	335.08	543.05 ± 13.95	852.13 ± 16.54	309.08
9	404.38 ± 8.88	731.55 ± 9.92	327.17	536.79 ± 12.23	833.97 ± 15.68	297.18
10	380.83 ± 3.52	714.34 ± 6.10	333.51	507.77 ± 13.02	795.75 ± 14.63	287.98
11	372.96 ± 2.68	705.70 ± 4.75	332.73	464.82 ± 9.05	758.73 ± 12.94	293.91
12	370.64 ± 4.95	695.72 ± 6.39	325.09	428.50 ± 6.96	730.62 ± 12.65	302.12
13	364.34 ± 3.23	689.89 ± 8.31	325.55	411.28 ± 7.12	715.00 ± 12.55	303.73
14	370.32 ± 4.60	695.41 ± 8.10	325.09	411.39 ± 7.74	717.27 ± 11.30	305.88
15	384.91 ± 11.39	702.83 ± 4.67	317.92	413.74 ± 7.44	722.15 ± 11.44	308.40
16	384.87 ± 9.97	710.06 ± 5.80	325.19	420.38 ± 9.00	721.94 ± 12.49	301.56
17	371.92 ± 2.24	714.26 ± 3.40	342.34	432.89 ± 8.18	737.43 ± 13.37	304.54
18	375.65 ± 1.87	716.85 ± 2.52	341.20	462.29 ± 7.29	772.53 ± 12.71	310.25
19	379.79 ± 1.99	722.22 ± 2.73	342.42	488.55 ± 8.39	797.41 ± 13.26	308.86
20	391.13 ± 2.55	734.56 ± 3.09	343.43	506.82 ± 8.89	817.99 ± 13.84	311.17
21	411.29 ± 4.35	754.46 ± 4.71	343.17	516.03 ± 7.69	831.38 ± 14.43	315.35
22	416.71 ± 4.62	759.02 ± 4.99	342.31	508.49 ± 7.87	825.50 ± 14.11	317.02
23	435.60 ± 5.11	778.68 ± 5.76	343.09	512.23 ± 8.64	829.91 ± 15.01	317.67
Range	124.16	121.47		190.63	189.47	

1.3.2 Temperature

During each experimental repetition, the four chambers varied in mean temperature by no more than 1.16°C, with the largest difference occurring between chambers 1 and 4 in repetition 1 at 1200 and 1600 hrs. The average difference between repetitions was 3.20°C, with the greatest difference in mean temperature being 6.03°C at 0800 hrs (figure 1.3). For reps. 1 and 2, respectively, average mean temperature reached highs of 26.67±0.22°C at 1200 hrs and 23.91±0.31°C at 1300 hrs, and lows of 17.70±0.22°C at 0500 hrs and 14.61±0.36°C at 0600 hrs.

During the day, the temperatures in the chambers were greater than the mean temperature in the greenhouse (figure 1.3). On average, the chamber temperatures exceeded the mean greenhouse temperature by 2.18 and 1.23°C for repetitions 1 and 2 respectively. The maximum difference for repetition 1 was 5.30°C at 1200 hrs. For repetition 2, the maximum difference was 2.66°C at 1300 hrs.

Initially the chambers were positioned in pairs of two along the greenhouse temperature gradient (figure 1.4a); however, this led to differences of greater than 4.00°C between the pairs. To correct this, the chambers were repositioned along the side of the greenhouse near the cooling pads, to diminish the heating effects of solar radiation (figure 1.4b).

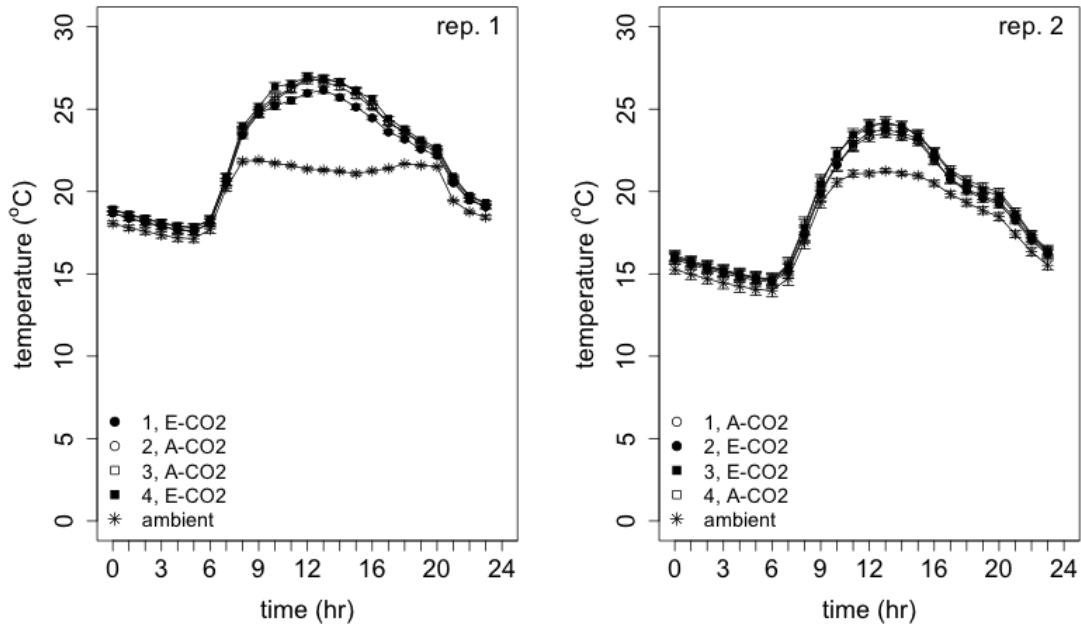

Figure 1.3 Mean diurnal temperatures in the four chambers, and outside the chambers (ambient) for experimental repetitions 1 and 2 (Rep 1 & 2) in the elevated (E) and ambient (Am) CO₂ chambers. Error bars are standard error of the mean.

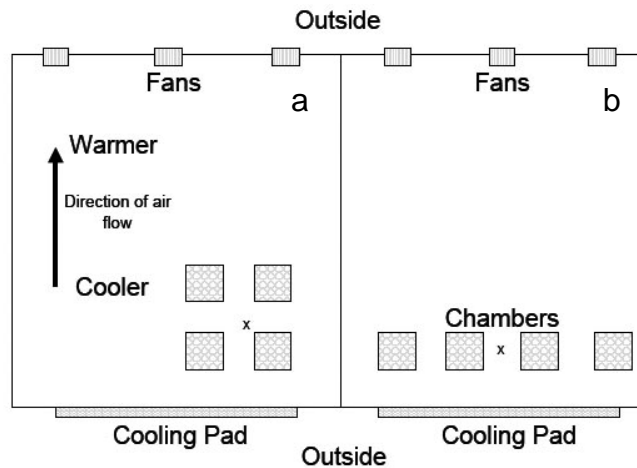

Figure 1.4 Chamber positions in greenhouse. Air coming into the greenhouse is cooled by water-radiated cooling pads and drawn through the greenhouse by suction fans at the opposite end. This created a temperature gradient, causing a temperature difference between the chamber pairs in their original positions (a). The chambers were rearranged parallel to the cooling pads (b). The 'x' is the position for the thermocouple that recorded the greenhouse temperature.

1.3.3 Plant Response

A complete discussion of plant growth is presented in chapter 2; however, plant biomass did respond positively to CO₂ indicating that CO₂ elevation was adequate to illicit a response.

1.3.4 Overview of Cost

I will consider cost of chamber construction and operation, as substitutions can be made in the equipment used to monitor CO₂ and temperature levels. The grand total for construction of four chambers, including the plumbing, fans and electrical components, frames, siding, and CO₂ regulation was \$2,808.16 (table 1.2). One 22.70 kg (50 lb) CO₂ tank supplied CO₂ to two of the four chambers for 11 to 14 days and cost \$25.01, meaning that the cost for a ten-week run was between \$125.00 and \$159.00.

1.3.5 Design Inadequacies

To begin, it must be recognized that there is considerable controversy as to whether enclosure apparatus, such as what is described here, and free air CO₂ enrichment (FACE) technology yield the same results (Ainsworth & Long 2005; Long et al. 2006; Tubiello et al. 2007; Ainsworth et al. 2008). However, as described by Gifford (2004),

overall results are similar between the two technologies, although yields of rice and wheat were reportedly lower in FACE experiments (Long et al. 2006).

Table 1.2 Summary of costs for chamber construction and operation. Cost of the monitoring system is

Category	Description	Total
chamber: plumbing	ductwork, PVC piping, sealants, clear tubing, etc.	\$355.44
air circulation	centrifugal inline fans, switches, wiring, etc.	\$560.98
frame	lumber, waterproof sealant, paint, PVC piping, misc. hardware	\$554.15
siding/top	clear Mylar sheet, 1/4"-thick PVC sheet	\$919.59
CO ₂ regulation	flow regulator for CO ₂ tank, bubble flow meters	\$418.00
Grand Total		\$2,808.16
operation: CO ₂	22.7 kg (50lb tank, lasts 11-14 days)	\$25.01
monitoring:	infrared gas analyzer, thermocouple temperature sensors, data logger	

not included as substitutions can be made.

Further, while the chambers did enable elevation of CO₂, there is much in way of the design that can be improved. First, in terms of CO₂ elevation, there were considerable differences between the two repetitions, drawing light to the fact that our regulatory system was crude and did not allow for precise control of CO₂ levels. However, maintaining CO₂ concentrations at a constant level is also not desirable. Diurnal CO₂ levels naturally fluctuate because of cycles of photosynthesis and respiration (George et al. 2007). Seasonal variation also occurs, especially in the northern latitudes (Goudriaan 1987 as cited in Lambers et al. 2006). Because variation does occur naturally, I am most concerned that the range between daily peaks and

troughs was larger than two studies that observed natural variation (George et al. 2007; Hackman 2009). It is likely that the broad range was due to nightly build up of CO₂ in the chambers as well as in the greenhouse. If the air-circulation component of the chambers is adjusted to bring air from outdoors, this may help to solve the problem.

The Mylar® material used for the chamber sides provided a durable, clear surface. However, it did not respond well to heat molding, and so clear tape was used to seal the Mylar® at the corners of the chambers. Although this was an effective solution the tape will likely need to be replaced periodically. A second disadvantage of the Mylar® was that it was difficult to stretch tightly over the chamber frame. Because of wrinkles and bulges in the sides, the area inside each chamber is slightly different, and is difficult to calculate. While this was adequate for our needs, modification of the design may increase the chambers' durability, and ease of use. If the Mylar® were stretched into frames, such that for each side Mylar® "window panes" were created and then attached to the internal PVC-pipe frame, the Mylar® may be easier to manipulate. Another possible material is Teflon®. Teflon® film has a solar transmission of 96% and is durable, tear resistant, flexible, and can be heat molded (DuPont 2009b). This is the material currently being used in the terracosms at the United States Environmental Protection Agency (EPA) Western Ecology Division's Terrestrial Ecology research site (Gregg 2009). If the modifications I have suggested were made to the sides, the chamber area would be easier to calculate and the sides may be easier to seal using foam tape or caulk. It may then be possible for the

chambers to be used to determine canopy level gas exchange rates similar to the method used by Shaver and colleagues (2007).

A third inadequacy was the inability to control temperature. Because we recognized that there was a temperature gradient across the greenhouse, we were able to move the chambers to account for this. In the future, fans could be added to the chambers to control temperature; however, a more sophisticated monitoring system would be required to turn them on and off as needed.

1.3.6 Conclusions

These chambers provided a mechanism by which to elevate CO₂ that was adequate for our needs as long as we were aware of the deficiencies and were able to account for them, and they did so with relatively little cost. I have proposed several suggestions for changes, however whether these changes are needed will depend on the needs and budgets of future studies. Finally, it is still necessary for these chambers to be tested in their other configurations (open-top, and removed from their bases) before they should be used in those manners.

CHAPTER 2. RESPONSE OF *PHALARIS ARUNDINACEA* AND *GLYCERIA STRIATA* TO CO₂ AND NITROGEN

2.1 INTRODUCTION

Current evidence suggests that there are detectable changes in the composition of ecosystems and distribution of plant species as a result of global change that includes changes in atmospheric deposition of nitrogen, elevated temperatures, changes in snow pack and precipitation, and increases in carbon dioxide concentrations (Vitousek et al. 1997; Poorter & Navas 2003; Cannone et al. 2008). Plant species display a range of biochemical and growth responses to increases of atmospheric carbon dioxide (CO₂). This range of responses will likely result in new plant-plant or plant-herbivore interactions that will influence higher order shifts in ecosystem services and feedbacks to the global carbon balance (Bradley & Pregitzer 2007). In an on going study using open-top chambers placed in the Chesapeake Bay, elevated CO₂ was found to increase the biomass of the C₃ *Scirpus olnei* after four years relative to the C₄ *Spartina patens* and *Distichlis spicata* (Drake 1992; Rasse et al. 2005). In a two-year study utilizing free-air CO₂ enrichment (FACE) technology, a dominant shrub, *Larrea tridentata*, increased shoot production by 50% in a wet year, and seed rain and aboveground growth increased in an invasive annual grass, *Bromus madritensis* ssp. *Rubens* (Smith et al. 2000).

Invasive plant species may best utilize increases in resources, especially carbon dioxide, as they tend to be more efficient, able to take in more carbon per unit energy

expended than non-invasive species (Nagel & Griffin 2004). For example, in a study comparing the response of plants to past, present, and projected levels of CO₂, six invasive species increased biomass under elevated CO₂ – an increase three times that of non-invasive species (Ziska 2003). Nagel and colleagues lend insight as to why. They found that the invasive *Lythrum salicaria* assimilated 208% more carbon per unit of energy invested in leaf biomass than two co-occurring native species, and under elevated CO₂ the sometimes weedy *Xanthium strumarium* was able to produce more biomass without increasing energy investments toward growth (Nagel & Griffin 2004; Nagel et al. 2005). Furthermore, these authors found that species abundance was negatively correlated with area-based leaf construction costs (Nagel & Griffin 2001). In other words, those species that were most abundant allocated relatively fewer carbon resources toward leaf growth.

Conversely, one strategy of native species is slow growth and long-lived leaves which is advantageous when resources are scarce (Grotkopp & Rejmanek 2007). Leaf longevity is negatively correlated with photosynthetic rate (Reich et al. 1992, 1997). Suárez (2003) found that as the ratio of construction costs relative to maximum photosynthetic rate increased, leaf longevity also increased. Faster growing species are then able to utilize resources when they become available by investing in more, short-lived growth, while the genetic background of slow-growing species limits their ability to increase photosynthesis under elevated CO₂.

2.1.1 Effects of Elevated CO₂ on Plant Growth

In general, elevated levels of CO₂ enhance plant photosynthetic rate. This in turn increases overall biomass, a trend that is most pronounced in fast growing C₃ species (Poorter & Navas 2003). Frequently, the enhancement of photosynthesis diminishes after prolonged exposure to elevated CO₂. However, this enhancement is in part because plants divert nitrogen away from photosynthetic apparatus towards the growth of other organs (Wolfe et al. 1998; Ainsworth & Rogers 2007). The overall result is still an increase in biomass even though individual leaves may be photosynthesizing at a rate lower than the initial stimulation. This conclusion is logical; growth rate is better correlated with total leaf area per plant than photosynthesis of a single leaf (Lambers et al. 2006).

The effect of elevated CO₂ on growth may be more important for species with indeterminate growth forms or large carbon sinks (Reekie et al. 1998; Ainsworth & Rogers 2007; Ziska 2008). For example, Ziska (2008) compared the response of two wheat cultivars to elevated CO₂. At ambient CO₂, the cultivar Marquis produced more tillers, but had a lower yield than the other cultivar, Oxen. Under elevated CO₂ there was no difference in yield, and Marquis had a significantly higher aboveground biomass. He theorized that indeterminate growth of Marquis (in this case tiller production) provided more sinks for available carbon, allowing that cultivar to take advantage of the additional CO₂.

A second result of the photosynthetic enhancement by CO₂ is a buildup of non-structural carbohydrates in plant tissue. Total nonstructural carbohydrates are defined as those carbohydrates that are not immediately used for growth, but that can be quickly remobilized for respiration or growth when needed (Smith 1968). Starch and fructan are two examples, and there are several demonstrations of nonstructural carbohydrates increasing in response to elevated CO₂. For example, a study comparing the response of several C₃ and C₄ grasses found that sugars, starch, and fructan all increased, with fructan concentrations increasing three fold in response to elevated CO₂ (Barbehenn et al. 2004). A second study considered the effects of elevated CO₂ in combination with temperature, and found elevated CO₂ to increase the fructan concentration in the leaves of *Pascopyrum smithii*, a C₃ grass, when grown at its optimal temperature, 20°C (Read et al. 1997).

There are a few consequences of carbohydrate accumulation. One result may be a down regulation of photosynthesis over time. Triose-phosphate (the precursor for sugar manufacture) builds up in the chloroplasts and acts as a negative feedback on photosynthesis. In the grass, *Poa alpina*, photosynthesis decreased with increasing carbohydrate concentrations, and in *Festuca vivipara*, photosynthesis was found to be dependent on leaf nitrogen (Baxter et al. 1995). The latter species exhibited an increase in nonstructural carbohydrates, primarily in fructan under elevated CO₂, and the carbon-to-nitrogen ratio tended to decrease in plant tissue with increasing CO₂ (Taub & Wang 2008). However, it has been suggested that carbohydrate storage as fructan, unlike storage as sucrose or starch, may decrease the feedback inhibition of

photosynthesis because it is stored in the vacuole (Bryant et al. 1999). A second implication of nonstructural carbohydrate accumulation is that specific leaf area declines, perhaps because accumulating sugars increase the density of leaves (Poorter & Navas 2003).

While no suite of characteristics accurately describes all invasive species, there are characteristics that may be more common among them. One of these, as described above, is high photosynthetic energy use efficiency, which may allow these species to utilize available CO₂ at a lower cost of construction (Nagel & Griffin 2004). A second characteristic, correlative to the first, is a high relative growth rate (Pattison et al. 1998; Grotkopp & Rejmanek 2007), perhaps in part due to their ability to produce many, short-lived leaves. These two characteristics lead logically to the conclusion that elevated CO₂, as a resource for growth, may enhance the spread of invasive species.

A third characteristic common among invasive species is vegetative spread (Reichard & Hamilton 1997). Some species spread by rhizomes or stolons, and can sprout from fragments of these structures. Rhizomes and stolons are also storage structures where non-structural carbohydrates accumulate. These stored resources allow them to persist into the fall or to sprout rapidly in the spring (Day & Dixon 1985; Lavergne & Molofsky 2004). *Phalaris arundinacea*, for example, was found to accumulate more non-structural carbohydrates in its rhizomes, and also had a faster germination rate in the dark (Tamura & Moriyama 2001). The relative amounts of nonstructural carbohydrates in storage structures such as rhizomes or stolons has been used by some researchers to gage the effectiveness of measures used to control the

invasion of perennial species (Comes 1971; Seebacher 2008). Given that elevated CO₂ leads to the accumulation of nonstructural carbohydrates, one question that has not yet been considered is how elevated CO₂ will impact the amounts of nonstructural carbohydrates in the tissue of invasive plants, and whether this might affect their ability to invade.

2.1.2 Effects of CO₂ in Conjunction with Nitrogen

Increases in the level of atmospheric CO₂ likely have and will lead to changes in plant growth; however, other human mediated resource changes have also lead to shifts in community structure. Wetlands, for example, are highly susceptible to fertilizer or contaminant-rich runoff from urban and agricultural lands (Zedler & Kercher 2005), and all ecosystem types are susceptible to the introduction of nitrogen-fixing weeds. *Sorghum halepense*, for instance, is able to invade nitrogen-poor, tall grass prairies with the help of nitrogen-fixing bacteria (Rout & Chrzanowski 2009). Both bring nutrients into systems that may have once been nutrient poor or alter soil chemistry in other ways. As influxes of nutrients into native habitats have been implicated in the spread of species invasion (Zedler & Kercher 2004), it is important to consider the effects of CO₂ in conjunction with these other factors.

Nitrogen is a resource that must be taken into account because plant growth and physiological processes can be impacted by the ratio of carbon to nitrogen in plant tissue. For example, a study utilizing a modeled approach, suggested that elevated CO₂

would cause an overall decrease in root nitrogen, which could result in decreased respiration and therefore increased root life span (Eissenstat et al. 2000). Further, photosynthetic rate was found to be dependent on the quantity of available nitrogen in leaves of *Festuca vivipara*, which decreased as nonstructural carbohydrates increased (Baxter et al. 1995).

In general, the effects of CO₂ are likely to be more pronounced in high nutrient environments. Whereas CO₂ increases are globally noted, anthropogenic increases in nitrogen deposition vary geographically. However, the combination can have dramatic effects. Poorter and Navas (2003) review multiple studies, which quantified the effects of elevated CO₂ on plant growth, noting that the majority of plants were grown in more or less optimal conditions. Effects would likely be less apparent in most natural environments, where nutrients would be the limiting factor. Nitrogen fixing species, for example, responded strongly to increased CO₂ in nutrient-poor environments (Poorter & Navas 2003). In terms of storage of nonstructural carbohydrates (which, as discussed above, are likely to increase under elevated CO₂), nitrogen may negate or dampen the effect of CO₂. While an increase from 0 to 10 mM of nitrogen increased non-structural carbohydrates in the vines of a grape species, increases of 10 to 20 mM caused a subsequent decrease (Cheng et al. 2004). Taking the concept further, barley was subjected to nitrogen starvation and then nitrogen reapplication (Wang et al. 2000). Fructan levels were found to increase during nitrogen starvation but then decrease when nitrogen was re-supplied.

2.1.3 Introduction of Species Used for Experiment

Phalaris arundinacea (reed canary grass) and *Glyceria striata* (fowl mannagrass, also called *Glyceria elata*) are rhizomatous, C₃, perennial grasses. *Glyceria striata* is native to North America; however, while native strains of *P. arundinacea* exist in historical records, much of what exists today may be hybrids of European strains that had been introduced to the continent (Lavergne & Molofsky 2007). Often facilitated by influxes of nutrients, namely nitrogen, *P. arundinacea* aggressively invades wetlands throughout the northern USA and southern Canada forming species-poor stands, and has been suggested as a model by which to understand species invasion (Lavergne & Molofsky 2004; Craft et al. 2007).

The success of *P. arundinacea* as an invader is due to several characteristics. Because it is able to overwinter underground via its rhizomes it can use resources stored in the rhizomes to sprout early and grow rapidly in the spring. In fact, *P. arundinacea* had a higher concentration of fructans and a higher dark germination rate than did two other species (Tamura & Moriyama 2001). It may also be that fructan contributes to the ability of *P. arundinacea* to overwinter. Tronsmo and colleagues (1993) found that although the total amount of non-structural carbons in *P. arundinacea* and a second grass species did not change upon subjection to cold temperatures, the overall proportions of small sugars increased while fructan levels decreased. Rhizomes have also been shown to enable *P. arundinacea* to grow into

shaded areas, which would be unfavorable for seedling germination (Maurer & Zedler 2002).

Additionally, *P. arundinacea* produces a spreading horizontal canopy when nutrients are available, that has been shown to shade its competitors, or a large root system that suppresses belowground growth of competitors when nutrients are low (Green & Galatowitsch 2002). This ability to respond strongly to a range of environmental conditions has led several to suggest that *P. arundinacea* exhibits morphological plasticity. In addition to nutrients, *P. arundinacea* has been shown to respond strongly to both competition and water level. For example, *P. arundinacea* increased its shoot-height-to-biomass ratio in response to competition with *Spartina pectinata*, and altered its growth from a sward under intermittent flooding to a tussock when flooding was constant (Miller & Zedler 2003; Herr-Turoff & Zedler 2007).

Because of its rapid growth and morphological plasticity, *P. arundinacea* is a good candidate to respond to increasing levels of CO₂. As it is rhizomatous, it further enables exploration of whether elevated CO₂ will impact the storage of compounds in rhizomes, and whether this may alter its ability to spread vegetatively. This grass also stores its nonstructural carbohydrates as fructan (sometimes referred to as fructosan), a form of storage that is found commonly in temperate grasses such as *P. arundinacea* (Smith 1968). Finally, as a perennial grass, *P. arundinacea* has been suggested for use as a biofuel crop (Wrobel et al. 2009).

Glyceria striata is native to much of the United States, and is found in similar habitats to *P. arundinacea* (Schooler et al. 2006). Dense growth of *G. striata* has been

shown to impede germination of *P. arundinacea*, and it has been suggested as an alternative to *P. arundinacea* as a cover crop in storm water wetlands (Lindig-Cisneros & Zedler 2001; Bonilla-Warford & Zedler 2002).

Interested in how these two species might response to future environments, we subjected *P. arundinacea* and *G. striata* to two levels of nitrogen and ambient or elevated CO₂ to test the effects of elevated CO₂ alone and in conjunction with nitrogen. We measured a number of physical, morphological, and physiological variables that included; water use, biomass, biomass allocation, leaf area, tiller number, photosynthetic rate at growth CO₂ concentrations, maximum rate of Ribulose-1,5-bisphosphate carboxylase oxygenase (Rubisco) functioning (V_{cmax}), and fructan, carbon, and nitrogen content.

2.2 MATERIALS AND METHODS

2.2.1 Plant Materials and Treatments

The experiment took place over two repetitions in the Douglas Research Conservatory green house, a facility of the University of Washington Botanic Gardens (47° 39' 27" N, 122° 17' 21", 10 m elevation), Seattle, WA in 2008. For the first repetition, because we were unable to collect sufficient viable seeds, we collected rhizome fragments of *P. arundinacea* from North Wetland, Luther Burbank Park (47° 35' 39" N, 122° 13' 39", 9 m elevation), Mercer Island, Washington on May 2, 2008. These were kept in cold

storage (4°C) for six to seven days, washed, clipped into segments (hereafter referred to as rametes), and stored in water at 4°C until used. The rametes varied in length up to 10 cm to ensure all had two buds (Miller & Zedler 2003). Twenty of the rametes were planted in potting soil in 4.4 L (1 gallon) blow-molded plastic pots and propagated in the green house for use during the second repetition.

Glyceria striata seeds were purchased from Frosty Hollow Ecological Restoration, Langley, Washington and kept in the Miller Seed Vault (15°C, 22% relative humidity) at the University of Washington Botanic Gardens until used. Seeds were planted on May 31 and Aug 29, 2008 for the first and second repetitions, respectively, into blow-molded seed trays in the green house after having been aerated for 24 hours using an aquarium air pump (Tetra Luft Pump, Tetra Sales, Blacksburg, VA, USA).

Because the response of plants in monocultures rather than when they are grown individually is correlated more strongly with plants grown in community settings (Poorter & Navas 2003), 18 *P. arundinacea* rametes and 33 *G. striata* seedlings were randomly selected for planting in each pot. Of these, three rametes and three seedlings were randomly chosen and dried at 70°C to a constant weight to determine starting biomass. The remaining 15 rametes (30 buds) and 30 seedlings were planted into sterilized construction grade sand (Salmon Bay Sand and Gravel, Seattle, WA, USA) in 13.2 L (3 gal) blow-molded plastic pots. Polyester filling (Polyfil®, Fairfield Processing Corp., Danbury, CT, USA) was used to fill the drain holes of the pots preventing sand from spilling, while allowing free water flow. The pots were

placed into 15.4 L (3.5 gal) natural-colored plastic buckets (CPS, Eagle, ID, USA). They were watered through a funnel placed between the side of the pot and bucket to simulate ground water efflux and filled to 10 cm from the bottom with either a high or low nitrogen solution (figure 2.1a). Any *G. striata* seedlings that died during the first week of each repetition were replaced.

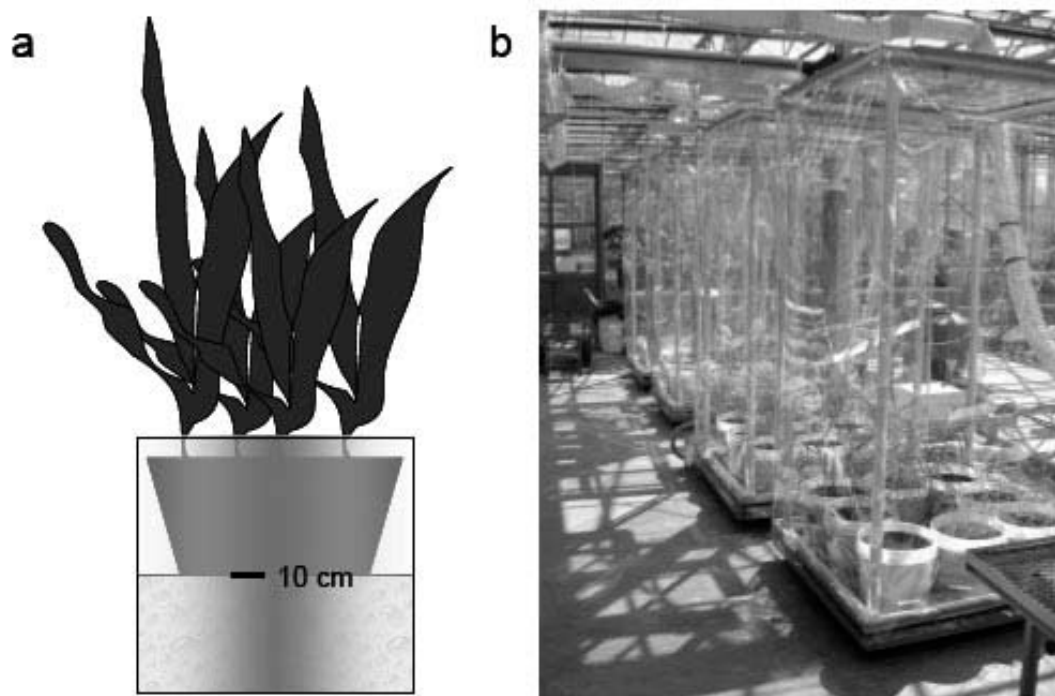

Figure 2.1 Potting method and chambers. Plants were planted into a 13.2 L (3 gal) pot, which was placed inside a 15.4 L (3.5 gal) bucket to allow the water level to be maintained at 10 cm (a). Chambers used to elevate CO₂ (b).

The high nitrogen solution was a full strength Hoagland's solution (Epstein 1972 cited in [Taiz & Zeiger 1998](#)) and contained three nitrogen components: KNO₃, Ca(NO₃)₂•4H₂O, and NH₄H₂PO₄. The low nitrogen solution had 1/8th of each nitrogen component maintaining their relative proportions, but full concentrations of all other components. Two pots for each plant and nitrogen combination were randomly placed

around the edge of each of four closed-top chambers for a total of eight pots per chamber. Two chambers were randomly assigned ambient CO₂ and two ranged approximately 320 ppm of CO₂ above ambient. The pot positions in the chambers and the CO₂ levels were randomly reassigned for repetition 2. Each experimental repetition lasted ten weeks. The first began July 7 and the second on September 21, 2008.

2.2.2 Chamber Construction, CO₂ Elevation, and Monitoring

The chambers (100 cm x 100 cm x 200 cm tall) were supported by 3.18 cm (internal diameter, 1.25 in) PVC pipe frames, which rested on wheeled, plywood bases that had been painted green to prevent rot and limit the absorption and reflection of light (figure 2.1b). The tops were clear 0.64 cm thick PVC sheets resting on a wood frame set atop the PVC pipe frame. Mylar® was stretched around the sides and attached to the top and bottom using Velcro®. Three of the corner seams were sealed with clear packing tape, while a fourth was sealed with Velcro® to allow access into the chambers. Air from near the greenhouse air intake was forced into the chambers via two inline fans (Model FR, Fantech, Sarasota, FL, USA) through a system of flexible aluminum ducting and consecutively smaller PVC pipes into the PVC pipe frames of the chamber. The chamber frames had been drilled with 0.64 cm (0.25 in) holes, 15 cm apart, around the bottom and up to 120 cm up the corner pipes. Each inline fan brought air to a pair of chambers, and within each pair, one chamber was randomly assigned to ambient and the other to elevated CO₂. CO₂ from a 22.70 kg (50 lb) tank (Praxair, Seattle, WA,

USA) was delivered to the elevated CO₂ chambers through 0.64 cm (1/4 in) clear Teflon® tubing, which was attached to the PVC pipe after the inline fan and 20 cm before the chamber, such that air from the fan would push the CO₂ into the chamber through the series of holes in the PVC pipe frame. The flow rate of CO₂ into the chambers was controlled using bubble flow meters (FL-2000, Omega, Stamford, CT, USA).

Chamber CO₂ concentrations were monitored by collecting air from each chamber using 0.64 cm (0.25 in) clear vinyl tubing connected to an infrared gas analyzer (CIRAS, PP Systems International, Inc., Amesbury, MA, USA). The elevated CO₂ chambers (hereafter “elevated chambers”) were connected to the reference port of CIRAS, while the ambient CO₂ chambers (hereafter “ambient chambers”) were connected to the analogue port. Because CIRAS is only capable of reading two samples at a time (the reference and analogue ports), the collecting tubes from the elevated chambers were first joined using plastic t-joints then connected to CIRAS, such that CIRAS read the average CO₂ concentration for the two chambers. The same was done for the ambient CO₂ chambers. The concentrations within the individual chambers were checked weekly to ensure similar concentrations within CO₂ treatments. CIRAS was calibrated at 0 and 700 ppm of CO₂ prior to the beginning of the experiment, then recalibrated at 700 ppm bi-weekly and then monthly after it was realized that CIRAS did not deviate by more than 5 ppm over the course of two weeks. All tubing, ducting, and plumbing were cut to ensure equal distances from the source to the chamber.

Temperature in each chamber was monitored using a pair of thermocouples placed 20 and 100 cm from the tops of the chambers. The thermocouple pairs were connected in parallel to provide the average temperature within a chamber, then run to a datalogger (CR1000, Campbell Scientific, Logan, UT, USA). Light levels outside of the greenhouse were collected using a quantum sensor (SQ-100, Apogee Instruments, Logan, UT, USA) and recorded in a datalogger (CR10, Campbell Scientific, Logan, UT, USA) (Hackman 2009). Temperature and light levels were recorded every 15 minutes, and CO₂ levels were recorded every 30 minutes. All were downloaded to a computer biweekly. Light levels inside the greenhouse were not recorded; however, greenhouse glass intercepts about 15% of incoming light (Fred Hoyt, University of Washington Botanic Gardens, pers. comm.), and the chambers likely intercept even more before light reaches the plants. Artificial light (high pressure sodium 400 watt single phase bulbs, Phillips Electronics North America Corp., Andover, MA, USA) was provided from 0800 to 2200 hrs daily.

2.2.3 Measurement of Morphological Parameters

Aboveground biomass was harvested over the weeks beginning September 21st and December 7th 2008. For most pots, three 49 cm² sub-samples were harvested, the tillers counted, and leaves separated from the stems at the ligules. Leaf area to the nearest 0.01 cm² was calculated using a leaf area meter (LI-3100, Li-Cor Inc., Lincoln, NE, USA), and the remaining tillers were harvested but not counted or separated into leaves

and stems (these are referred to hereafter as the “remainder”). Because there was a range in the number of rametes per pot that produced new growth and in the number of seedlings that survived, pots with less than 30% cover were harvested in their entirety.

Belowground biomass was harvested over a period of five weeks beginning October 1st and December 15th 2008. Belowground parts were washed using a gentle stream of water over a 2 mm mesh, then, either immediately or after storage for no longer than 5 days at 0°C, *P. arundinacea* was separated into roots, new rhizome growth, and original rametes. *Glyceria striata* was separated into roots, plant bases with rhizomes, and plant bases without rhizomes. The number of rametes that produced new growth or the number of seedlings that survived was recorded. Pots were randomly chosen for harvest and were stored at 40°C until they could be washed and processed. All plant material was dried at 70°C to a constant weight and weighed to the nearest 0.01 g.

Single datums for leaf and stem biomass, tiller number, and leaf area were found for each pot by determining the leaf-to-total-aboveground-biomass ratios, tiller-number-to-aboveground-biomass ratios, and leaf-area-to-aboveground-biomass ratios of the three subplots. The values for the three subplots were averaged, and applied to the biomass of the remainder to estimate leaf and stem biomass, tiller number, and leaf area of the remainder. Then all four values (the values from the subplots and the estimated values for the remainder) were added together to give a total for each pot. Using the estimated total leaf and stem biomass and the total rhizome and root biomass for each pot, the average biomass for an individual within a pot was found by dividing

these biomass parameters by the number of rametes or seedlings that had survived to produce new growth. Similarly, average tiller number and leaf area per individual within a pot were found by dividing the estimated total tiller number and leaf area per pot by the number of rametes or seedlings that had survived. It was these average values of the individuals within a pot that were ultimately assessed, and included the following: leaf, stem, rhizome, root and whole-plant biomass, tiller number, and leaf area. The morphological parameters were also used to determine the following: specific leaf area (the fraction of leaf area over dry leaf weight), ratios of the individual parts to whole-plant biomass (hereafter called leaf-mass ratio, stem-mass ratio, rhizome-mass ratio, and root-mass ratio), belowground-to-aboveground-biomass ratios, and rhizome-to-root ratios.

2.2.4 Determination of Water Use

Plants were watered up to 10 cm from the base of the bucket. The amount added at each watering was recorded, and then totaled at the end of each experimental repetition. **This value was divided by the number of rametes or seedlings that had survived per pot to give the average water use for an individual plant within each pot.**

2.2.5 Determination of Photosynthetic Rate (A), Rubisco Functioning (V_{cmax}), and Stomatal Conductance (g_s)

Measurement of carbon assimilation (A) and stomatal conductance was recorded

over a range of internal leaf carbon concentrations (C_i) during morning hours over the last two weeks of each repetition using a portable gas analysis system (LI-6400, Li-Cor Inc., Lincoln, NE, USA). From each pot, one fully expanded, non-shaded leaf either second or third from the top was chosen for measurement, with the light source set at $1500 \mu\text{mol m}^{-2} \text{s}^{-1}$ and the reference CO_2 ranging from 0 to 1500 ppm. CO_2 was provided to the leaf beginning at 400 ppm, decreasing to 0 ppm, and then increasing again to 1500 ppm. Leaves were allowed to stabilize for three minutes at each CO_2 level, and measurements were taken after no longer than ten minutes. The sample and reference ports were matched daily prior to use and before each measurement was taken. One chamber, and four pots representing each plant and nutrient treatment were randomly selected for measurement each day. From these data, A- C_i curves were constructed, and the data were fitted using the curve-fitting model designed by Sharkey and colleagues (2007) to estimate V_{cmax} for Rubisco activity. The photosynthetic rate at growth CO_2 concentrations and stomatal conductance were also compared.

2.2.6 Determination of Fructan, Carbon, and Nitrogen Content in Rhizomes

For *P. arundinacea*, the percent fructan content of the rhizomes was determined using a Fructan Assay Kit (Megazyme International, Bray, Ireland). Rhizomes were dried at 70°C to a constant weight, ground to pass a 0.5 mm mesh in a mill (Wiley Mini Mill, Thomas Scientific, Swedesboro, NJ, USA), and then hand ground using a mortar and pestle, if necessary, to obtain the required sample amount. Because of the variability in percent fructan of *P. arundinacea* rhizomes found in previous studies using this

method (Seebacher 2008), 1 g, which is the amount suggested for small concentrations of fructan was used.

Briefly, the assay procedure hydrolyses sucrose to D-fructose and D-glucose using a sucrase enzyme, and any starch or maltosaccharides present to D-glucose by amylase, pullulanase, and maltase. The resultant sugars are reduced to sugar alcohols using alkaline borohydride. Fructan is then hydrolyzed to D-fructose and D-glucose by fructanase, and the D-fructose and D-glucose absorbance is read using a p-hydroxybenzoic acid hydrazide (PAHBAH) reagent at 410 nm. The formula used to calculate the percent weight of fructan to total dry weight is as follows:

$$\%w/w = \Delta A \times F \times V/W \times 2.48$$

Where ΔA is the difference between the sample and blank absorbances, F is a factor to convert absorbance values to μg of D-fructose (54.5 μg D-fructose/absorbance for 54.4 μg), V is the volume of extractant used, and W is the weight of the sample extracted.

For one representative of each treatment per experimental repetition, total percent carbon and percent nitrogen of the rhizomes for both *P. arundinacea* and *G. striata* were determined by placing ground sample, prepared as above, in 502-186 tin foil cups then combusted at 925°C to determine C-H-N content (Series II CHNS/O Analyzer 2400, Perkin Elmer, Waltham, MA, USA). For both species, analyses on the following were conducted: percent carbon, percent nitrogen, and carbon-to-nitrogen

ratio. For *P. arundinacea* the following additional comparisons were also analyzed: percent fructan, grams fructan in rhizomes, portion of whole-plant biomass that was allocated to fructan per pot, and fructan-to-total-carbon ratio.

2.2.7 Experimental Design and Statistical Analysis

The experimental repetitions were blocked to account for variability that could be attributed to differences between them. The experimental design, then, constituted a two-way main effects split-plot design with time (the repetitions) and CO₂ being main plots and nitrogen being the subplot. Statistical analyses to test for effects of CO₂, nitrogen, and their interaction were done using a general-linear-mixed-effects model (lmer in the lme4 package developed by Douglas Bates, Martin Maechler, and Bin Dai) in R version 2.8.1 (R Development Core Team (2008), Vienna, Austria), in which CO₂, nitrogen and their interaction were included as fixed effects, and time was considered random. Variability due to the chamber pairs (one fan supplied air to two chambers) and individual chambers were also included in the model as random effects. To ensure the data met the assumption of equal variance, some data were transformed based on the results of Box-Cox Power Transformations and graphical comparisons of transformed and non-transformed data (App. A). The variance expressed in this report is standard error of the mean, and the number of individual pots for *P. arundinacea* and *G. striata* were 31 and 32, respectively. Results were considered significant at $\alpha = 0.05$.

Degrees of freedom for the nitrogen effect and CO₂-and-nitrogen interaction were calculated from the total number of pots. Any effect due to CO₂ was further assessed by the following: 1) by comparing the linear-mixed-effects model with and without CO₂, and 2) by comparing the model with and without a random effect due to individual chambers. The former comparison served to provide evidence as to whether there was a CO₂ effect, and the latter provided assurance that individual chambers explained little or no variability. If the models in the former comparison were found significantly different ($p < 0.05$, i.e. that CO₂ did contribute significant variability among treatments) and the latter was found insignificant (i.e. that the variability could not be explained by innate differences among the chambers), then significance of the overall model was computed using degrees of freedom calculated from the total number of pots.

In some instances, data from individual repetitions were analyzed separately. Then the number of individuals for *P. arundinacea* was 15 and 16 for the first and second repetitions, respectively, and 16 for *G. striata* for both repetitions. When individual repetitions were analyzed separately, CO₂ effects were considered significant at $\alpha = 0.10$ because of the small sample size.

2.3 RESULTS

2.3.1 CO₂ Elevation, Temperature, and Light Levels

Carbon dioxide (CO₂) levels fluctuated daily in both the ambient and elevated chambers, with the lowest levels recorded during the day. This pattern, as well as the CO₂ levels, differed between the first and second repetition (figure 2.2). During repetition 1, the levels in the ambient and elevated chambers, respectively, ranged from lows of 364.34±3.23 and 689.89±8.31 ppm at 1300 hrs to highs of 485.81±11.63 and 826.99±13.42 ppm at 0600 hrs, for a total daily range of 121.47 and 124.16 ppm (table 1.1). During repetition 2, the levels ranged from lows of 411.28±7.12 and 715.00±12.55 at 1300 hrs to highs of 600.75±65.95 and 905.63±61.93 at 0300 hrs, for a total daily range of 189.47 and 190.63 ppm for the ambient and elevated CO₂ chambers, respectively. The duration of the daily drawdown due to photosynthesis was shorter for repetition 2, lasting 4 hrs vs. approximately 10 hrs for repetition 1. The average difference between repetition 1 and repetition 2 in the ambient chambers was 75.11±6.01 ppm, with repetition 2 being higher. The average difference between repetition 1 and repetition 2 in the elevated chambers was 65.53±5.36 ppm, with repetition 2 again being higher.

During each experimental repetition, the four chambers varied in mean temperature by no more than 1.16°C, with the largest difference occurring between

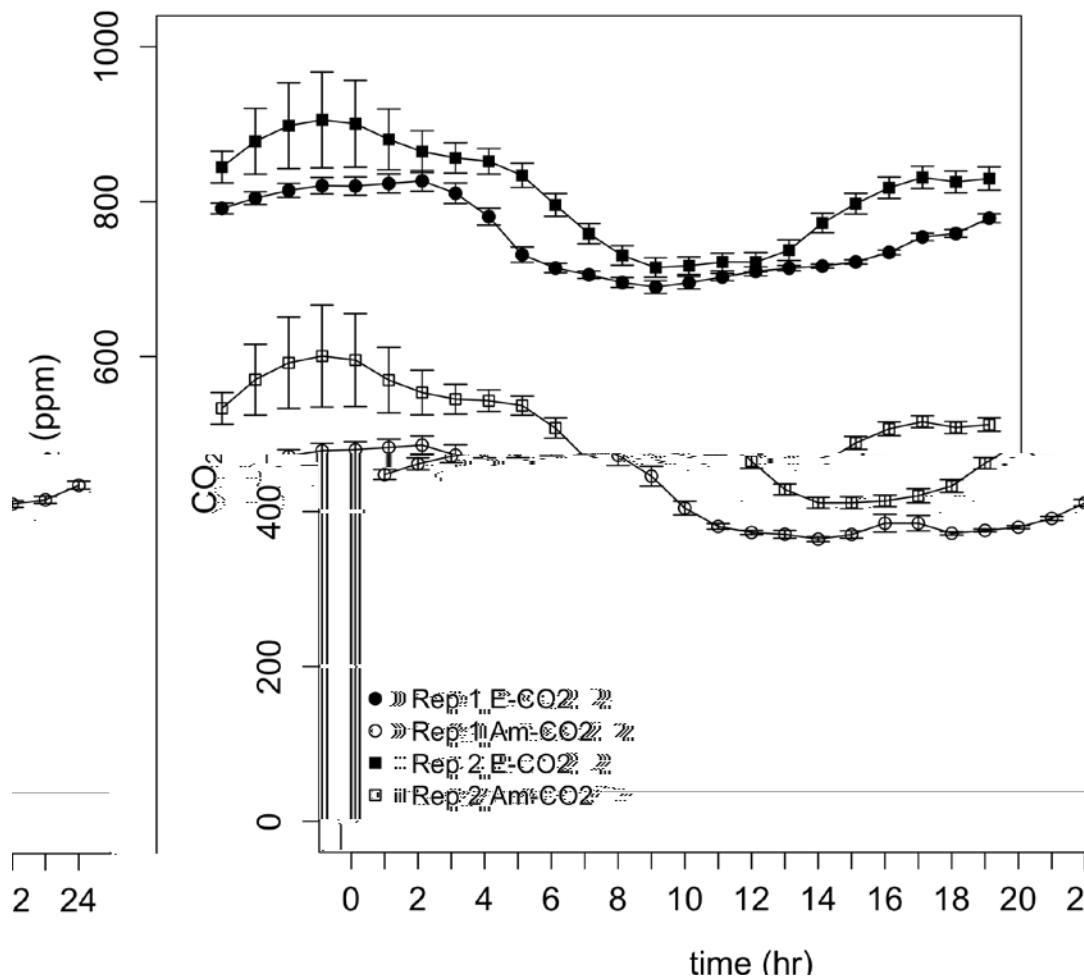

Figure 2.2 Mean diurnal CO₂ levels for the first and second experimental repetitions (Rep 1 & 2) in the elevated (E) and ambient (Am) CO₂ chambers. Repetitions ran for 10 weeks and began on July 7th and September 21st, 2009.

chambers 1 and 4 in repetition 1 at 1200 and 1600 hrs. The average difference in mean temperature between repetitions was 3.20°C (figure 2.3), with the greatest difference being 6.03°C at 0800 hrs. The temperature peaked at 26.67±0.22°C at 1200 hrs and 23.91±0.31°C at 1300 hrs for repetitions 1 and 2, respectively. The temperature reached lows of 17.70±0.22°C at 0500 hrs and 14.61±0.36°C at 0600 hrs for repetitions 1 and 2, respectively.

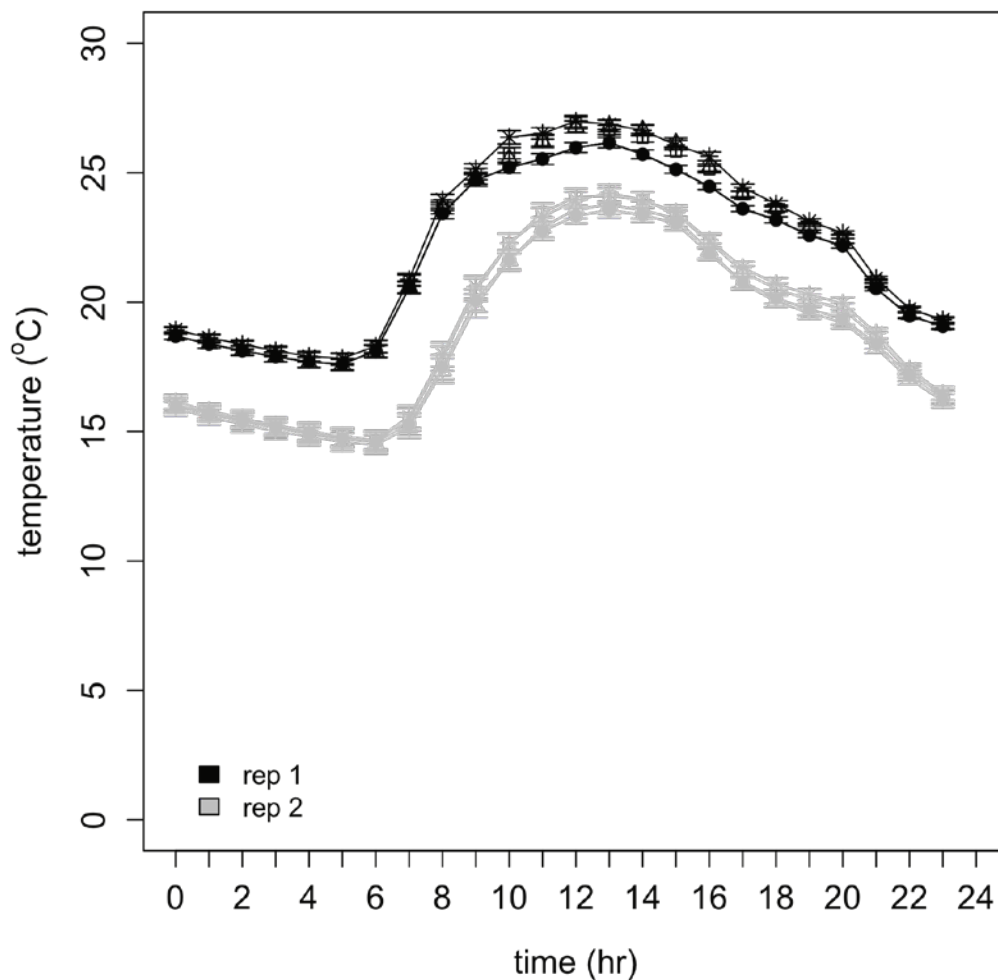

Figure 2.3 Mean diurnal temperatures inside the chambers for the first and second experimental repetitions (Rep 1 & 2) in the elevated (E) and ambient (Am) CO₂ chambers. Repetitions ran for 10 weeks and began on July 7th and September 21st, 2009.

The external light levels coming into the greenhouse differed both in day length and intensity between the two repetitions (figure 2.4). The average difference in hourly means was $349.24 \mu\text{mol m}^{-2} \text{s}^{-1}$, with the greatest difference being $970.85 \mu\text{mol m}^{-2} \text{s}^{-1}$ at 1300 hrs. The average maximum was 1411.79 ± 110.08 and $524.96 \pm 40.44 \mu\text{mol m}^{-2} \text{s}^{-1}$ for repetitions 1 and 2, respectively.

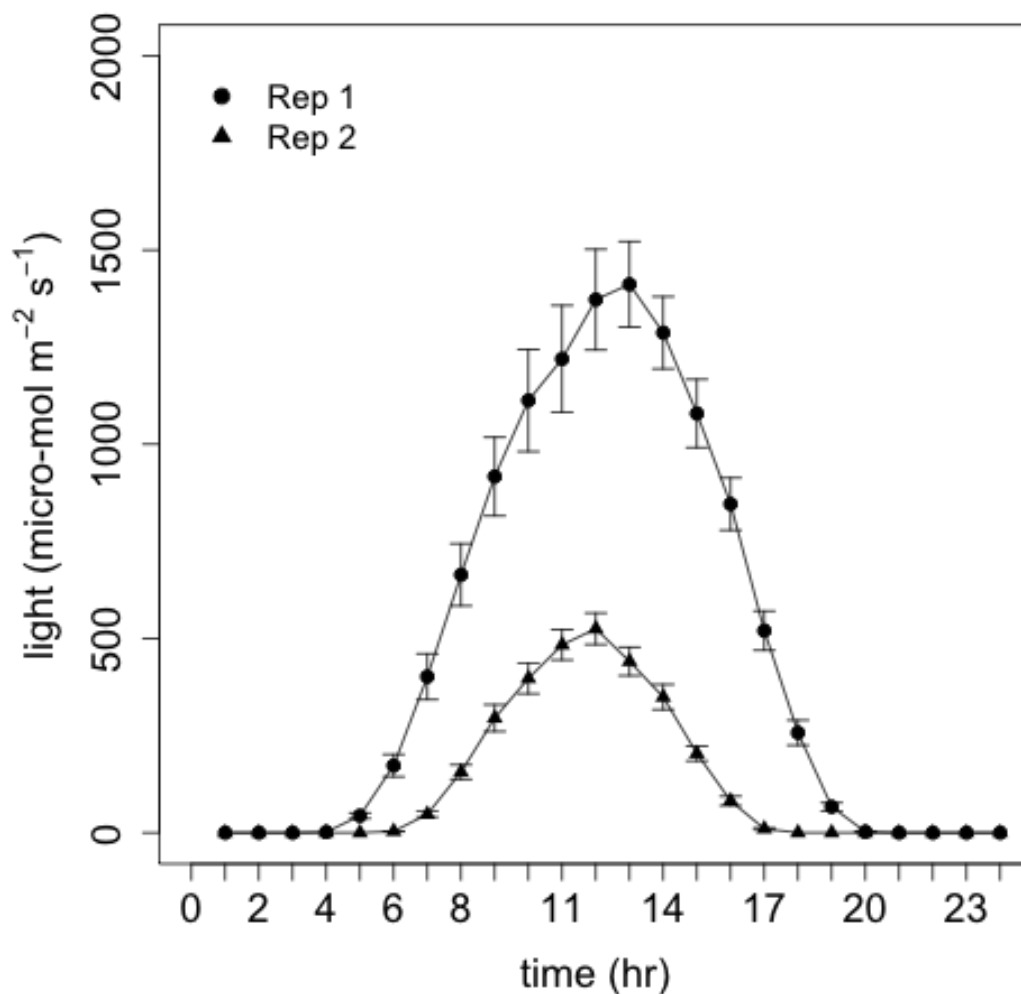

Figure 2.4 Mean diurnal light levels outside the greenhouse for the first and second experimental repetitions (Rep 1 & 2). Repetitions ran for 10 weeks and began on July 7th and September 21st, 2009.

2.3.2 Absolute Biomass

2.3.2(a) *Phalaris arundinacea*

For *P. arundinacea* the whole-plant biomass exhibited significant CO₂ and nitrogen effects (table 2.1, figure 2.5, $p < 0.05$ and 0.001, respectively). Plants grown in elevated CO₂ and high nitrogen had a 301% increase in biomass over plants grown

in ambient CO₂ and low nitrogen, while plants grown in ambient CO₂ and high nitrogen had an 81% increase in biomass. The increase in whole-plant biomass was driven primarily by an increase in aboveground growth. Stem biomass increased significantly in response to CO₂ and nitrogen ($p < 0.01$ and 0.05 , respectively), with the plants in the elevated CO₂, high nitrogen treatments having a 344% increase in biomass over those in the ambient CO₂, low nitrogen treatments. Leaf biomass followed a similar pattern with an increase of 428%; however, CO₂ was only significant in repetition 1 ($p < 0.1$), with an increase of 103% from ambient to elevated CO₂. Nitrogen was significant overall ($p < 0.001$). The fitted mean values for leaf biomass in repetition 1 were 2.41 ± 2.87 and 2.72 ± 3.91 g for plants grown in low nitrogen under ambient and elevated CO₂, respectively, and 6.16 ± 1.88 and 14.67 ± 2.66 g for plants grown in high nitrogen under ambient and elevated CO₂, respectively.

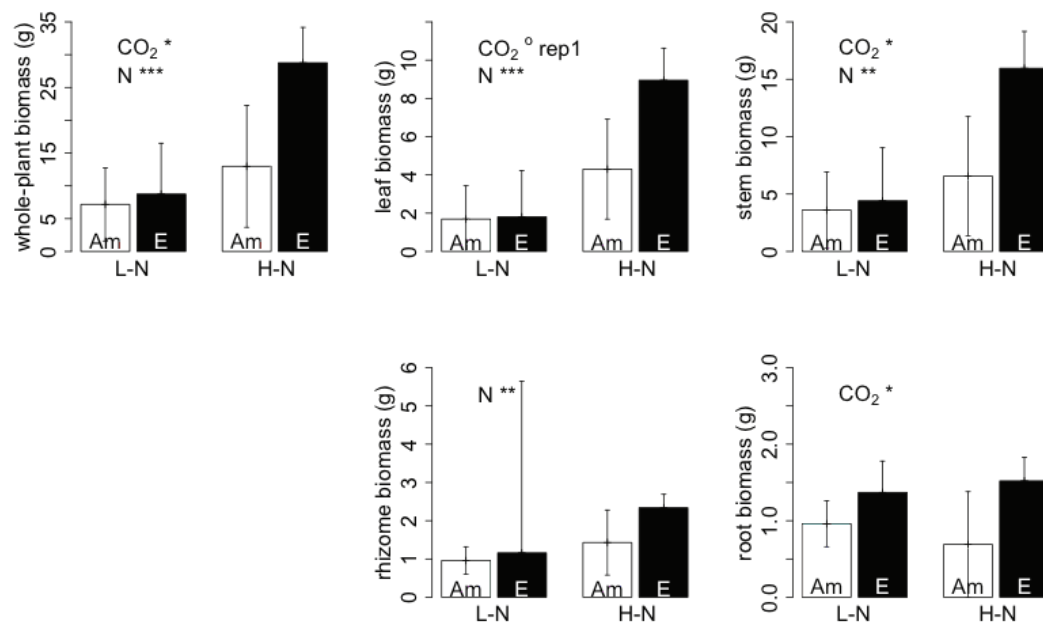

Figure 2.5 Average whole-plant biomass for individuals grown within a pot for *Phalaris arundinacea* as well as the biomass for leaves, stems, rhizomes, and roots in the ambient (Am) CO₂, elevated (E) CO₂, low nitrogen (L-N), and high nitrogen (H-N) treatments. Significance values: $\alpha = 0.1$ ($^{\circ}$), 0.05 (*), 0.01 (**), 0.001 (***). Error bars are standard error of the mean.

Rhizome biomass per individual exhibited only a nitrogen effect ($p < 0.01$), with plants grown in high nitrogen having a 78% increase in biomass over those grown in low nitrogen. Conversely, root biomass exhibited only a CO₂ effect (figure 2.5, $p < 0.05$), with the roots of plants grown in elevated CO₂ having a 74% increase in biomass over those grown in ambient CO₂. There was also a significant difference between repetitions in whole-plant biomass per individual grown within a pot ($p < 0.01$), with the fitted means for whole-plant biomass being 41.38 ± 7.77 and 23.57 ± 4.87 g for repetitions 1 and 2, respectively. Differences between repetitions in the other biomass parameters were not assessed.

Table 2.1 *Phalaris arundinacea* means and standard error for average biomass, tiller number, leaf area and water use for individuals grown within a pot, and specific leaf area for the ambient (A) and elevated (E) and high (H) and low (L) nitrogen treatments. Shading indicates data were transformed to fit assumptions of variance. Significance values: $\alpha = 0.1$ (°), 0.05 (*), 0.01 (**), 0.001 (***)).

<i>P. arundinacea</i>				
		Fitted means		Significance
whole-plant biomass/ individual (g)	A_H	12.98 ± 9.30		
	E_H	28.77 ± 5.39	CO2	*
	A_L	7.18 ± 5.58	N	***
	E_L	8.75 ± 7.76	CO2xN	ns
tiller number/ individual	A_H	13.37 ± 4.66		
	E_H	22.06 ± 3.22	CO2	ns
	A_L	5.78 ± 3.33	N	***
	E_L	7.78 ± 4.63	CO2xN	ns
SLA (cm ² g ⁻¹)	A_H	322.79 ± 59.92		
	E_H	276.08 ± 20.21	CO2	* (rep1)
	A_L	295.58 ± 20.95	N	ns
	E_L	291.33 ± 29.11	CO2xN	ns
water use (ml)	A_H	3126.25 ± 316.90		
	E_H	5067.10 ± 194.10	CO2	* (rep1)
	A_L	3144.80 ± 197.20	N	* (rep2)
	E_L	3284.90 ± 273.90	CO2xN	° (rep1)
Leaf area/ individual (cm ²)	A_H	808.70 ± 316.90		
	E_H	1260.50 ± 194.10	CO2	° (rep1)
	A_L	386.30 ± 197.20	N	***
	E_L	481.90 ± 273.90	CO2xN	ns

2.3.2(b) *Glyceria striata*

Average whole-plant biomass per individual within a pot for *G. striata* exhibited a CO₂ and nitrogen effect, and a strong CO₂ and nitrogen interaction (figure 2.6, $p < 0.01$, 0.001, 0.05). As with *P. arundinacea*, *G. striata* plants grown in the elevated CO₂, high nitrogen treatments exhibited the strongest response overall, with the greatest response being in aboveground biomass. There was a 405% increase in leaf biomass over the ambient CO₂, low nitrogen treatments, and a 537% increase in stem biomass. In comparison, the ambient CO₂, high nitrogen treatments exhibited a 154% increase in

Table 2.2 *Glyceria striata* means and standard error for average biomass, tiller number, leaf area and water use for individuals grown within a pot, and specific leaf area for the ambient (A) and elevated (E) and high (H) and low (L) nitrogen treatments. Shading indicates data were transformed to fit assumptions of variance. Significance values: $\alpha=0.1$ (°), 0.05 (*), 0.01 (**), 0.001 (***).

<i>G. striata</i>					
		Fitted means			Significance
whole-plant biomass/ individual (g)	A_H	1.63	± 0.80		
	E_H	3.54	± 0.49	CO2	**
	A_L	0.75	± 0.43	N	***
	E_L	0.82	± 0.61	CO2xN	*
tiller number/ individual	A_H	9.38	± 2.70		
	E_H	11.80	± 1.54	CO2	ns
	A_L	6.02	± 1.22	N	**
	E_L	5.16	± 1.75	CO2xN	** (rep1)
SLA (cm ² g ⁻¹)	A_H	232.43	± 67.41		
	E_H	219.31	± 29.21	CO2	ns
	A_L	206.27	± 29.21	N	ns
	E_L	231.51	± 41.31	CO2xN	ns
water use/ individual (ml)	A_H	686.72	± 154.99		
	E_H	891.28	± 86.40	CO2	*
	A_L	495.15	± 73.40	N	**
	E_L	422.44	± 105.91	CO2xN	**
Leaf area/ individual (cm ²)	A_H	4.67	± 0.2088		
	E_H	5.28	± 0.2953	CO2	*
	A_L	3.82	± 0.2282	N	***
	E_L	4.04	± 0.3292	CO2xN	ns

leaf biomass and a 158% increase in stem biomass over the ambient CO₂, low nitrogen treatments. While leaf, stem, and rhizome biomass responded to both nitrogen and CO₂, root biomass responded only to CO₂ (figure 2.6, $p < 0.05$), increasing 117% from ambient to elevated CO₂. A similar pattern was observed with *P. arundinacea*.

The CO₂-and-nitrogen interaction demonstrated by whole-plant and stem biomass, as well as by leaf biomass in repetition 1 (figure 2.6, $p < 0.05$), was in all three cases driven by the plants grown in the elevated CO₂, high nitrogen treatments. There was also a significant difference between repetitions in whole-plant biomass for individuals grown within a pot ($p < 0.05$), with the fitted means for whole-plant biomass being 3.84 ± 0.84 and 2.43 ± 0.54 g for repetitions 1 and 2, respectively. Differences between repetitions in the other biomass parameters were not assessed.

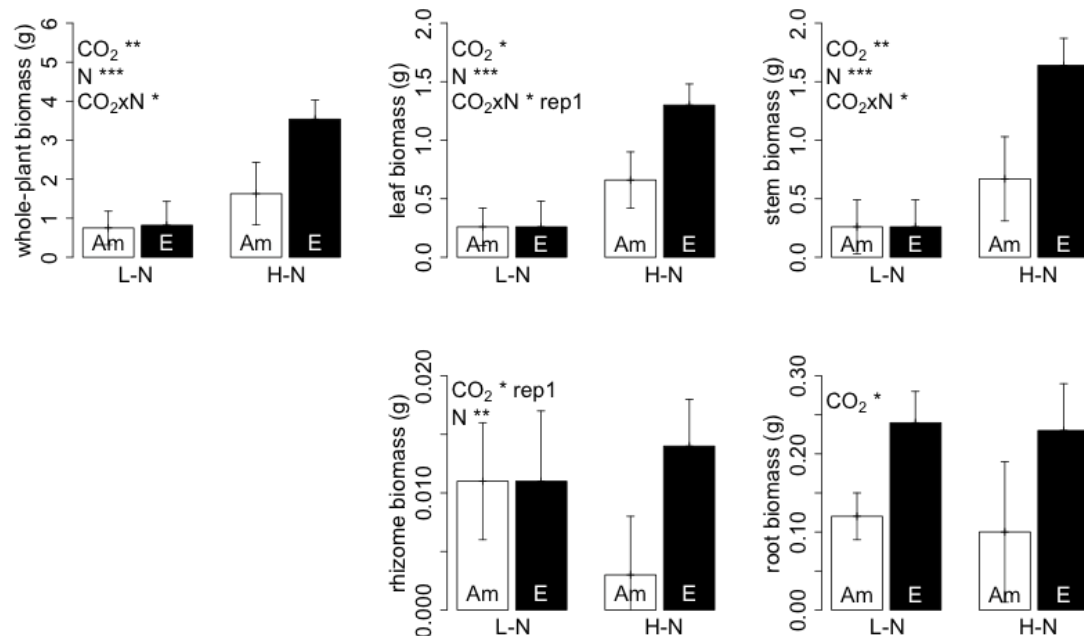

Figure 2.6 Average whole-plant biomass for individuals grown within a pot for *Phalaris arundinacea* as well as the biomass for leaves, stems, rhizomes, and roots in the ambient (Am) CO₂, elevated (E) CO₂, low nitrogen (L-N), and high nitrogen (H-N) treatments. Significance values: $\alpha = 0.1$ (°), 0.05 (*), 0.01 (**), 0.001 (***). Error bars are standard error of the mean.

Rhizome biomass responded significantly to nitrogen (figure 2.6, $p < 0.01$), which seems to be driven primarily by the decrease of biomass in the ambient CO₂, high nitrogen treatments, as there is an average decrease in biomass from low to high nitrogen of 21%. CO₂ elicits a significant response in repetition 1 ($p < 0.05$), and there, the pattern is clearer. The plants grown in elevated CO₂ had higher overall rhizome biomass than those grown in ambient CO₂, with the fitted mean rhizome biomass per individual in the ambient CO₂ treatments having 0.015 ± 0.006 and 0.006 ± 0.004 g under low and high nitrogen, respectively, and the elevated CO₂ treatments having 0.016 ± 0.008 and 0.019 ± 0.005 g.

2.3.3 Biomass Allocation

2.3.3(a) *Phalaris arundinacea*

Phalaris arundinacea demonstrated an overall nitrogen effect in its belowground-to-aboveground-biomass ratio (figure 2.7, $p < 0.001$), with a decrease of 53% from the low to high nitrogen treatments. Considering only the belowground portions, *P. arundinacea* exhibited a significant nitrogen effect in the rhizome-to-root-biomass ratio ($p < 0.001$), with an overall 120% increase in allocation to rhizomes from low to high nitrogen. In repetition 1, there was also a significant CO₂ and nitrogen interaction ($p < 0.05$). There was an overall 25% decrease in allocation to rhizomes from ambient to elevated CO₂ treatments; however, this was driven primarily by elevated CO₂ and high nitrogen. The fitted means for the rhizome-to-root-biomass ratio in repetition 1 were

0.90±0.21 and 0.87±0.28 under ambient and elevated CO₂ in the low nitrogen treatments, respectively, and in the high nitrogen treatments they were 2.21±0.28 and 1.48±0.32.

Phalaris arundinacea plants grown in high nitrogen had a significant, 40%, increase in leaf-mass ratio over those grown in low nitrogen treatments (figure 2.7, $p<0.001$), while CO₂ and the CO₂-and-nitrogen interaction were not significant. Rhizome and root-mass ratios responded to nitrogen in the opposite direction, with 22% and 45% decreases in biomass being allocated to rhizomes and roots, respectively, from the low to high nitrogen treatments ($p<0.05$ and 0.001, respectively).

The CO₂ effect on rhizome-mass ratio was shown to be significant in repetition 1 (figure 2.7, $p<0.05$), driven by the plants grown under elevated CO₂ and high nitrogen. This treatment had the lowest fitted mean ratio, which was 0.075±0.02 of whole-plant biomass allocated to rhizomes. The ambient CO₂, high nitrogen treatments had a mean ratio of 0.11±0.02, and the low nitrogen treatments grown under ambient and elevated CO₂ had fitted mean ratios of 0.14±0.03 and 0.13±0.03, respectively. The CO₂ effect on stem-mass ratio was shown to be slightly significant in repetition 1 (figure 2.7, $p<0.10$), driven again by the plants grown under elevated CO₂ and high nitrogen (fitted mean ratio 0.56±0.02). The fitted mean ratio for ambient CO₂, high nitrogen treatments was 0.51±0.02, and the fitted means for low nitrogen treatments were 0.50±0.02 and 0.52±0.03 under ambient and elevated CO₂, respectively.

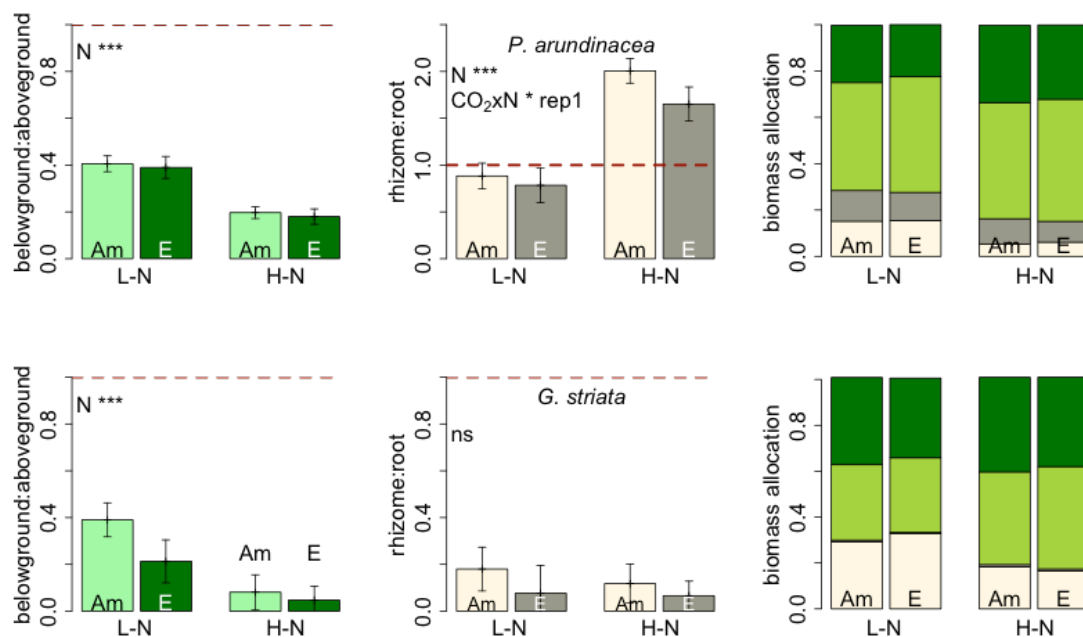

Figure 2.7 From left to right, mean belowground:aboveground and rhizome:root ratios, and whole plant allocation patterns for leaves (dark green), stems (light green), rhizomes (brown), and roots (light brown) for *Phalaris arundinacea* (top) and *Glyceria striata* (bottom) in the ambient (Am) CO₂, elevated (E) CO₂, low nitrogen (L-N), and high nitrogen (H-N) treatments. Significance values: $\alpha=0.1$ ($^{\circ}$), 0.05 (*), 0.01 (**), 0.001 (***). The significance for the biomass allocation for *P. arundinacea* is as follows: leaves (N^{***}), stems (N° rep2, CO_2° rep1), rhizomes (N^* rep2, CO_2^* rep1), and roots (N^{***}). The significance for the biomass allocation for *G. striata* is as follows: leaves (N^{**} rep1), stems and rhizomes (N^{**}), and roots (N^{***}). Error bars are standard error of the mean.

2.3.3(b) *Glyceria striata*

Glyceria striata only demonstrated a nitrogen effect in the belowground-to-aboveground-biomass ratio (figure 2.7, $p<0.001$), with a 79% decrease in allocation belowground from low to high nitrogen. Considering only belowground growth, there was no difference across treatments in the rhizome-to-root-biomass ratio (figure 2.7).

For *G. striata*, leaf-mass ratio was only significant in repetition 1, however, it demonstrated a nitrogen rather than CO₂ effect (figure 2.7, $p < 0.01$), increasing 28% from low to high nitrogen. The fitted mean leaf-mass ratios for repetition 1 in low the nitrogen treatments were 0.30 ± 0.0183 and 0.27 ± 0.0259 under ambient and elevated CO₂, respectively, and in the high nitrogen treatments the ratios were 0.37 ± 0.0245 and 0.36 ± 0.0271 , respectively. Stem-mass ratio exhibited a significant nitrogen effect overall (figure 2.7, $p < 0.01$), with a 30% increase in biomass allocated to stems from the low to high nitrogen treatments. Rhizome and root-mass ratios, also responded to nitrogen ($p < 0.01$ and 0.001 , respectively), showing 78% and 44% decreases in biomass allocated to rhizomes and roots from the low to high nitrogen treatments, respectively.

2.3.4 Tiller Number, Leaf Area, Specific Leaf Area

2.3.4(a) *Phalaris arundinacea*

For *P. arundinacea*, tiller number responded strongly only to nitrogen ($p < 0.001$), with a 190% increase from low to high nitrogen. Average leaf area for the individuals within a pot demonstrated a significant effect due to nitrogen (table 2.1, $p < 0.001$), as well as to CO₂ in repetition 1 ($p < 0.1$). There was an overall increase of 138% from low to high nitrogen and an increase of 46% from ambient to elevated CO₂ in repetition 1. In low nitrogen, the fitted mean values for leaf area in repetition 1 were 584.40 ± 365.10 and 691.60 ± 497.50 cm² for the ambient and elevated CO₂ treatments, respectively. In high

nitrogen, they were 1015.00 ± 242.20 and $1809.10 \pm 337.90 \text{ cm}^2$, respectively. The CO_2 effect on specific leaf area was shown to be significant (table 2.1, $p < 0.05$), with a decrease of 8% from ambient to elevated CO_2 . Specific leaf area also exhibited significant differences between the experimental repetitions ($p < 0.001$). Plants from repetition 2 had a higher specific leaf area than those from repetition 1 (237.82 ± 15.16 and $120.57 \pm 24.20 \text{ cm}^2 \text{ g}^{-1}$, respectively).

2.3.4(b) *Glyceria striata*

Tiller number demonstrated a significant nitrogen effect and, in repetition 1, a CO_2 -and-nitrogen interaction (table 2.2, $p < 0.01$). Tiller number increased 89% from low to high nitrogen, with the strongest response occurring under elevated CO_2 . Under that condition, tillers increased 96% over the ambient CO_2 , low nitrogen treatments. Leaf area demonstrated a significant effect due to CO_2 and nitrogen (table 2.2, $p < 0.05$ and 0.001 , respectively). There was an overall increase of 27% from low to high nitrogen and an increase of 10% from ambient to elevated CO_2 . Specific leaf area exhibited no significant effect overall; however, as with *P. arundinacea*, repetition 2 had a significantly higher specific leaf area than repetition 1 ($p < 0.01$, 157.32 ± 60.48 and $27.32 \pm 38.25 \text{ cm}^2 \text{ g}^{-1}$, respectively).

2.3.5 Water Use

2.3.5(a) *Phalaris arundinacea*

In average water use per individual within a pot, *P. arundinacea* did not show a significant CO₂ effect overall, although there was a trend (table 2.1, $p < 0.1$), with a 33% increase from ambient to elevated CO₂. The trends were clearer when considering individual repetitions. In repetition 1, there was a significant CO₂ effect and a CO₂-and-nitrogen interaction ($p < 0.05$ and 0.1, respectively), both driven by a 51% increase in water use under elevated CO₂ and high nitrogen over the ambient CO₂, low nitrogen treatments. In repetition 2, there was a significant nitrogen effect ($p < 0.05$), with an increase of 48% from the low to high nitrogen treatments. The fitted means for water use in repetition 1 for plants grown in low nitrogen were 5486.80 ± 1146.00 and 5075.10 ± 1561.00 ml under ambient and elevated CO₂, respectively, and the high nitrogen treatments were 4671.70 ± 750.20 and 8265.80 ± 1061.00 ml. The fitted means in repetition 2 for plants grown in low nitrogen were 841.90 ± 442.40 and 1494.80 ± 625.70 ml under ambient and elevated CO₂, respectively, and the high nitrogen treatments were 1580.90 ± 328.90 and 1868.50 ± 442.40 ml.

2.3.5(b) *Glyceria striata*

Overall, *G. striata* showed significant responses to CO₂, nitrogen, and their interaction in average water use for individuals within a pot, (table 2.2, $p < 0.05$, 0.01,

and 0.01, respectively). There was a 72% increase from low to high nitrogen, and an 11% increase from ambient to elevated CO₂. As with *P. arundinacea*, water use was highest in the plants grown in elevated CO₂ and high nitrogen, with an 80% increase over the ambient CO₂, low nitrogen treatments.

2.3.6 Photosynthetic Rate (A), Rubisco Functioning (V_{cm_{max}}), and Stomatal Conductance (g_s)

2.3.6(a) *Phalaris arundinacea*

Phalaris arundinacea exhibited a nitrogen effect on maximum rate of Rubisco functioning (V_{cm_{max}}, [table 2.3](#), $p < 0.05$), having a 26% higher efficiency in the high nitrogen treatments. *Phalaris arundinacea* also exhibited a significant CO₂ effect with photosynthetic rate at growth CO₂ concentrations ([table 2.3](#), $p < 0.001$). The plants grown in elevated CO₂ had an average 53% higher rate of photosynthesis than those grown in ambient CO₂. The nitrogen treatment was also significant ($p < 0.05$), with the plants grown in high nitrogen treatments having a 23% higher rate of photosynthesis than those grown in low nitrogen. *Phalaris arundinacea* exhibited no significant differences in stomatal conductance at growth CO₂ concentrations.

2.3.6(b) *Glyceria striata*

Glyceria striata demonstrated a similar pattern with V_{cm_{max}} in repetition 1. Only

nitrogen was significant (table 2.3, $p < 0.05$), with a 64% increase in the high nitrogen treatments. *Glyceria striata* also exhibited a significant response to CO₂ with photosynthetic rate (table 2.3, $p < 0.01$). The plants grown under elevated CO₂ had a 66% higher photosynthetic rate than those grown under ambient CO₂. Overall, the plants did not respond significantly to nitrogen, although there was a trend ($p < 0.1$), with a 69% increase in photosynthetic rate from low to high nitrogen. *Glyceria striata* exhibited no significant differences in stomatal conductance at growth CO₂ concentrations.

Table 2.3 Means and standard error for photosynthesis (A), stomatal conductance (g_s), and V_{cmax} of Rubisco for *Phalaris arundinacea* and *Glyceria striata* for the ambient (A) and elevated (E) and high (H) and low (L) nitrogen treatments. Shading indicates data were transformed to fit assumptions of variance. Significance values: $\alpha = 0.1$ (°), 0.05 (*), 0.01 (**), 0.001 (***)

		Fitted means		Significance	
P. arundinacea	A ($\mu\text{mol m}^{-2} \text{s}^{-1}$)	A_H	15.59 ± 2.214		
		E_H	24.06 ± 1.574	CO2	***
		A_L	12.75 ± 1.634	N	*
		E_L	19.43 ± 2.269	CO2xN	ns
	g_s	A_H	0.4049 ± 0.0675		
		E_H	0.4596 ± 0.0716	CO2	ns
		A_L	0.4596 ± 0.0745	N	ns
		E_L	0.4255 ± 0.1034	CO2xN	ns
	V_{cmax}	A_H	63.75 ± 4.43		
		E_H	62.63 ± 4.27	CO2	ns
		A_L	52.24 ± 4.44	N	*
		E_L	48.38 ± 6.16	CO2xN	ns
G. striata	A ($\mu\text{mol m}^{-2} \text{s}^{-1}$)	A_H	9.863 ± 1.511		
		E_H	17.69 ± 2.137	CO2	**
		A_L	6.663 ± 2.137	N	ns
		E_L	9.666 ± 3.002	CO2xN	ns
	g_s	A_H	0.2857 ± 0.0571		
		E_H	0.2493 ± 0.0393	CO2	ns
		A_L	0.3274 ± 0.0345	N	ns
		E_L	0.2596 ± 0.0488	CO2xN	ns
	V_{cmax}	A_H	36.63 ± 4.79		
		E_H	38.50 ± 6.77	CO2	ns
		A_L	24.38 ± 6.77	N	*
		E_L	21.50 ± 9.58	CO2xN	ns

(rep1)

2.3.7 Fructan, Carbon, and Nitrogen Content in Rhizomes

2.3.7(a) *Phalaris arundinacea*

Phalaris arundinacea rhizomes exhibited a significant nitrogen effect on the carbon-to-nitrogen ratio (figure 2.8, $p < 0.001$), having a higher carbon-to-nitrogen ratio in the low nitrogen treatments. This pattern was driven both by a significant 7% decrease in percent carbon and a 168% increase in nitrogen from the low to high nitrogen treatments.

Phalaris arundinacea also displayed an overall nitrogen effect on percent fructan in rhizomes (figure 2.9, $p < 0.001$). Following a similar pattern to that of carbon, fructan decreased 68% from the low to high nitrogen treatments. Repetition 2 also displayed a significant CO₂-and-nitrogen interaction ($p < 0.05$), driven by a higher percentage in the elevated CO₂, low nitrogen treatments (fitted mean $11.71 \pm 1.28\%$). The ambient CO₂, low nitrogen treatments had a mean of $8.20 \pm 0.91\%$ and the high nitrogen treatments had fitted means of 3.14 ± 1.51 and $3.79 \pm 1.15\%$ under ambient and elevated CO₂, respectively.

For *P. arundinacea*, the fructan-to-total-carbon ratio in the rhizomes responded significantly to nitrogen (figure 2.9, $p < 0.001$), decreasing 62% from low to high nitrogen. This pattern was driven both by a significant 7% decrease in percent carbon and a 68% increase in nitrogen from the low to high nitrogen treatments. There was

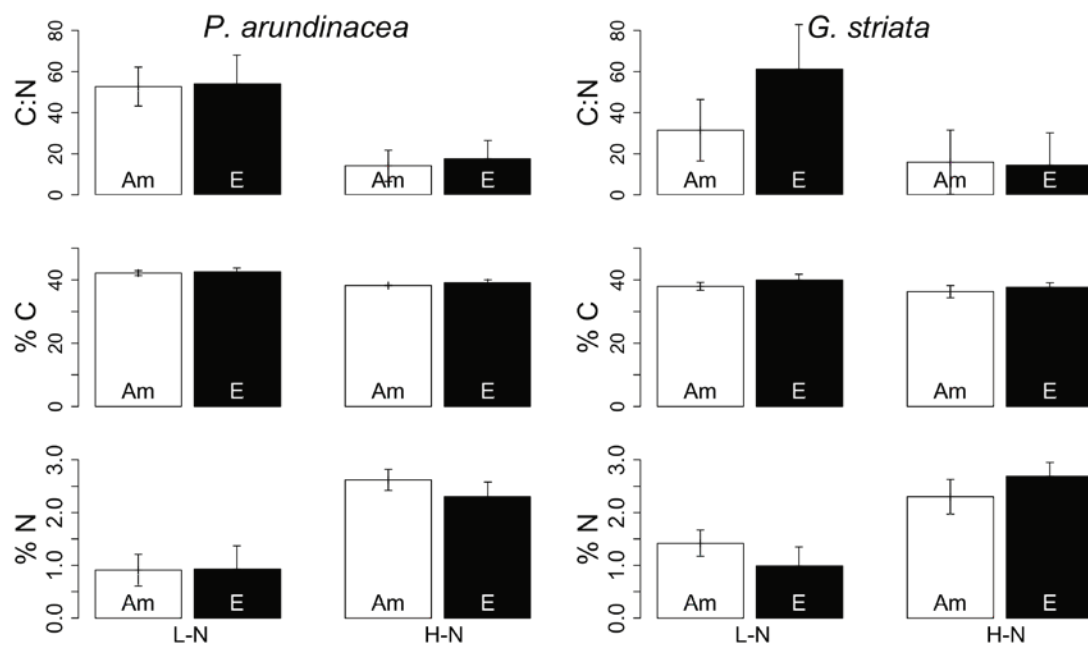

Figure 2.8 The carbon-to-nitrogen ratio, percent carbon, and percent nitrogen content of rhizomes of *Phalaris arundinacea* and *Glyceria striata* in the ambient (Am) CO₂, elevated (E) CO₂, low nitrogen (L-N), and high nitrogen (H-N) treatments. Significance values: $\alpha=0.1$ ($^{\circ}$), 0.05 (*), 0.01 (**), 0.001 (***). Error bars are standard error of the mean. The significance for *P. arundinacea* are as follows: C:N, %C, and %N (N***). The significance for *G. striata* are as follows: C:N (N***, CO₂xN*), %C (ns), and %N (N**, CO₂xN*). Error bars are standard error of the mean.

also a significant CO₂-and-nitrogen interaction (figure 2.9, $p<0.05$), due to a 39% increase in the fructan-to-total-carbon ratio from the ambient to elevated CO₂ plants grown with low nitrogen, and a 24% decrease from the ambient to elevated CO₂ plants grown in high nitrogen.

2.3.7(b) *Glyceria striata*

Glyceria striata rhizomes also exhibited significant nitrogen effects on the carbon-to-nitrogen ratio (figure 2.8, $p<0.001$), having higher carbon-to-nitrogen ratios in the low

nitrogen treatments. This pattern was driven by percent nitrogen in the rhizomes, which increased 107% from the low to high nitrogen pots, because there was no significant difference in percent carbon. In addition, the carbon-to-nitrogen ratio demonstrated a significant CO₂-and-nitrogen interaction ($p<0.05$), driven by a 94% increase in the plants grown in elevated CO₂ and low nitrogen over those in the ambient CO₂, low nitrogen treatments. Again, this pattern was due to a 30% decrease in nitrogen between those treatments, rather than an increase in carbon.

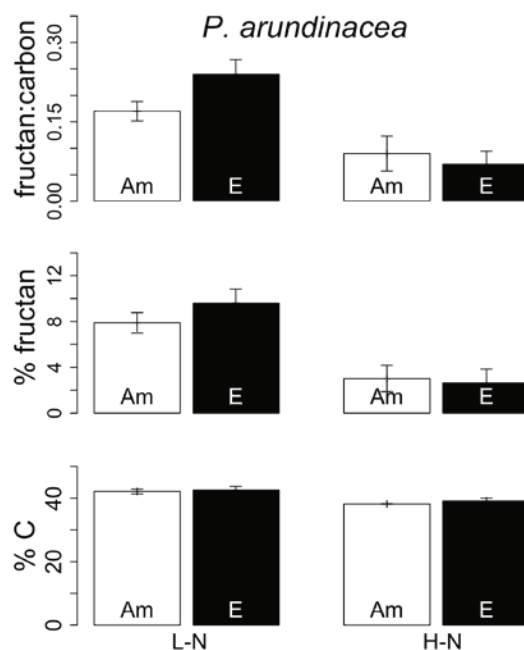

Figure 2.9 The fructan-to-carbon ratio, percent fructan, and percent carbon content of rhizomes of *Phalaris arundinacea* in the ambient (Am) CO₂, elevated (E) CO₂, low nitrogen (L-N), and high nitrogen (H-N) treatments. Significance values: $\alpha=0.1$ (°), 0.05 (*), 0.01 (**), 0.001 (***). Error bars are standard error of the mean. The significance is as follows: fructan:carbon (N***, CO₂xN*), %fructan (N***, CO₂xN* rep2), and %carbon (N***).

2.4 DISCUSSION

2.4.1 CO₂ Elevation, Temperature, and Light Levels

CO₂ fluctuated diurnally in both the ambient and elevated chambers, drawing down during the day as plants photosynthesized and peaking at night as plants respired. This pattern is consistent with patterns measured outdoors in the Puget Sound region; however, the range from high point to low point in our chambers was much greater – approximately 120 ppm in repetition 1. In the Puget Sound region, CO₂ fluctuated approximately 45 ppm from the nightly high point to the mid-day low point (Hackman 2009). In another study near Baltimore, MD, CO₂ fluctuated to a greater extent, with one site having a one-year average range that was similar to the ranges observed in our chambers during repetition 1 (George et al. 2007). The five-year average for that site, however, was around 100 ppm – still less than the range of approximately 120 ppm found here. The reason for the higher ranges observed in our chambers may have been a nightly build up of CO₂ as plants respired in the confined greenhouse or chamber space (for a more detailed discussion of chamber design and inadequacies, see Chapter 1). In fact, the nightly high in the ambient chambers exceeded the outdoor high at the site by 58 ppm (Hackman 2009). The daily low in the ambient chambers differed from the outdoor low at the site by only 2 ppm.

Between experimental repetitions there were differences in CO₂ levels, as well as in temperature and light levels. It is difficult to determine for certain how much each of these factors contributed to perceived growth differences between repetitions;

however, it is possible to draw some conclusions from the literature. Several studies have now been conducted along a rural to urban gradient, along which CO₂ concentrations increase. The difference in CO₂ in urban and rural settings is in some cases comparable to the differences between repetition 1 and repetition 2 in this experiment, and plants have demonstrated a response to increased CO₂ in this context (Ziska et al. 2007; Hackman 2009). For example, Ziska and colleagues (2007) saw an average difference between urban and rural sites of 92 ppm over four years, and Hackman (2009) saw an average difference of 30 ppm between two urban sites and a rural site over **periods of about four weeks**. The average differences between repetitions in this experiment were 75 and 66 ppm for the ambient and elevated chambers, respectively. Even during the daytime when the differences between repetitions were less pronounced, the difference between the midday lows in the ambient chambers (47 ppm) exceeded both daytime and nighttime differences between the urban and rural sites observed by Hackman (2009). It is likely, then, that plants would respond to the differences observed here between repetitions. However, whole-plant biomass was lower in repetition 2, although CO₂ levels were higher. Further, as light levels were also lower in repetition 2, plants had less light energy with which to take up carbon, so perhaps the effect of higher CO₂ on plant growth in repetition 2 was not as pronounced as it would have been given similar light levels. For a more detailed discussion regarding the reason for the differences in CO₂ between repetitions, see chapter 1.

Temperature could have also played a role as C₃ species assimilate carbon more efficiently at lower temperatures (Lambers et al. 2006). However, the response to CO₂ was driven primarily by the results in repetition 1 when temperatures were higher. Thus, temperature, at least, did not impede growth in this experiment.

Most likely, the differences in outside day length and light intensity contributed to the observed growth differences between repetitions, although the artificial light was not altered. Photosynthetic efficiency and therefore carbon assimilation and growth are dependent on light energy, and the majority of parameters tested showed the strongest response to CO₂ in the first repetition, when day length and light intensity were highest. Further, as is evidenced by decreases in average whole-plant biomass from repetition 1 to repetition 2 in both species, productivity was lower in repetition 2. Finally, there were strong differences in specific leaf area across treatments and in both species between the two repetitions. Plants grown in repetition 2 had higher specific leaf areas than those in repetition 1, consistent with patterns found in sun vs. shade grown plants (Lambers et al. 2006).

2.4.2 Morphological Parameters

2.4.2(a) *Phalaris arundinacea*

Overall, nitrogen contributed most significantly to the majority of growth parameters tested for *P. arundinacea*. This is not surprising. *Phalaris arundinacea* responds

strongly to nitrogen fertilization and does so over several growth parameters (Lavergne & Molofsky 2004). In fact, Craft and colleagues (2007) sampled several wetlands in Wisconsin, USA and found that *P. arundinacea* occurred in wetlands where nitrogen fertilization was highest. They concluded that this plant could be used as an indicator of nitrogen pollution in wetlands. However, CO₂ also contributed to the growth parameters observed in this study. Whole-plant biomass increased under elevated CO₂, driven by stem and leaf (repetition 1) biomass. As leaf biomass increased, so did leaf area (repetition 1), while tiller number responded only to nitrogen. For *P. arundinacea*, stems increased in size or perhaps density, but not in number in response to elevated CO₂.

The response to elevated CO₂ was most apparent in plants grown in high nitrogen. Other researchers have noted that CO₂ most strongly affects growth in high nutrient areas. Nitrogen-fixing species responded most positively to elevated CO₂ in low nutrient environments (Poorter & Navas 2003). One mechanism for this phenomenon is that plants with large carbon sinks are better able to take advantage of additional CO₂. The size of the sink can be regulated by several factors, including nutrient availability (Ainsworth and Long 2005). Nutrients, such as nitrogen, are needed for plants to utilize the additional carbon.

The belowground-to-aboveground-biomass ratio showed a response only to nitrogen, decreasing from low to high nitrogen. However, allocation to stems slightly increased under elevated CO₂ and high nitrogen in repetition 1, while allocation to rhizomes decreased. This perhaps indicates a shift from belowground to aboveground

growth when resources (CO₂ and nitrogen) are plentiful. Considering only the belowground portions, both CO₂ and nitrogen had an effect on the rhizome-to-root ratio in repetition 1. Allocation to rhizomes increased overall in high nitrogen, but did so to less of an extent under elevated CO₂.

It is interesting that allocation to belowground portions did not increase under elevated CO₂. Some researchers have theorized that plants will increase allocation to roots to offset the greater carbon accumulation under elevated CO₂ (Drake 1992, but see Poorter & Nagel 2000). However, here, the rhizome-to-root ratio may indicate a similar response. Perhaps when nitrogen is plentiful, *P. arundinacea* shifts belowground growth from nutrient acquisition to storage or vegetative spread, but under elevated CO₂, *P. arundinacea* attempts to compensate for increased carbon by shifting some biomass to nutrient acquisition. This conclusion is further supported by the fact that root biomass responded only to, and increased under, elevated CO₂ under both nutrient regimes.

The growth responses reported here are consistent with those found by Stock and Evans (2006). They observed that *P. arundinacea* biomass increased under elevated CO₂ and high nitrogen when grown alone. This is contrary to a study by Kao-Kniffin and Balser (2007), which found no effect of CO₂ when *P. arundinacea* was grown in near monoculture or mixed communities. One reason for the differences in results may be the CO₂ levels used. Stock and Evans used an elevated CO₂ level of 700 ppm, Kao-Kniffin and Balser used 600 ppm, and we had an average of 764.96 ppm in repetition 1.

Specific leaf area decreased under elevated CO₂ in repetition 1. This coincides with other research that found specific leaf area to decrease in response to CO₂ (Poorter & Navas 2003). One explanation for this phenomenon is that carbon accumulates in the leaf tissues, increasing the density or thickness of the leaves (Poorter & Navas 2003). The fact that specific leaf area responds significantly only to CO₂, and only in repetition 1, lends further support to CO₂ playing a role, but only in the higher light conditions of repetition 1.

2.4.2(a) *Glyceria striata*

When looking only at the means, both *P. arundinacea* and *G. striata* had similar patterns in response to the treatments, with the elevated CO₂, high nitrogen pots having the greatest response. While the nitrogen response of *G. striata* showed similar levels of significance to those of *P. arundinacea*, its response to CO₂ was much stronger in absolute biomass. If the experimental repetitions are considered separately, it is clear that the first repetition drove this response. Yet, the responses of several of the biomass parameters (whole-plant, leaf, and stem) were strong enough to be apparent even when the repetitions were considered together. Further, the degree of change in *G. striata* is greater than in *P. arundinacea*, with the most striking contrast being in stem biomass per individual. The percent increase from the ambient CO₂, low nitrogen treatments to the elevated CO₂, high nitrogen treatments is 537% vs. 344% in *P. arundinacea*.

It is likely that the response in stem biomass is partially contributable to an increase in tiller numbers under elevated CO₂ in repetition 1, as tiller number also responded positively. The increase in leaf biomass contributed, as well, to the canopy with an increase in leaf area. Perhaps both of these findings indicate that *G. striata* is better able to utilize the levels of CO₂ and nitrogen tested here as a resource to increase its canopy volume than *P. arundinacea*. Whether CO₂ and high nitrogen would increase the competitive ability of *G. striata* over *P. arundinacea* would require further study, however.

Like *P. arundinacea*, *G. striata* also increased its root biomass under elevated CO₂ across both nitrogen levels. Again, this pattern of increase differed from all other biomass parameters tested. Even in the low nitrogen treatments, root biomass was higher than those of the plants grown in ambient CO₂, regardless of nitrogen level. Although the rhizome-to-root-biomass ratio did not show any response to either treatment, the pattern was similar to that found in *P. arundinacea*. It is possible that *G. striata* also increases allocation to roots under elevated CO₂.

Finally, while specific leaf area decreased from ambient to elevated CO₂ in *P. arundinacea*, there was no significant change in *G. striata*. If specific leaf area decreased in *P. arundinacea* because it accumulated carbon in its leaves, perhaps *G. striata* does not utilize that strategy.

2.4.3 Water Use

One observed response to elevated CO₂ is a decrease in stomatal aperture resulting in reduced transpiration and water use (Drake et al. 1997, Gifford 2004). That did not occur here. In fact, in both *P. arundinacea* and *G. striata* water use increased in response to elevated CO₂, especially in high nitrogen, with the response being much stronger in *G. striata*. There are likely two reasons for their response. The first is an increase in leaf area under elevated CO₂ and high nitrogen. This increased the surface area over which transpiration could occur. Second, stomatal conductance was not altered in response to either treatment. Perhaps, as these are wetland grasses, and grow where water conservation is typically not important, these species do not respond to elevated CO₂ by decreasing stomatal aperture.

2.4.4 Photosynthesis (A) and Rubisco Functioning (V_{cmax})

2.4.4(a) *Phalaris arundinacea*

Sometimes plants respond to long-term exposure to elevated CO₂ by down regulating their rate of photosynthesis from the increase that occurred at the initial stimulation (Raper & Peedin 1978; Tissue & Oechel 1987). One reason for down regulation may be because plants are able to assimilate carbon more efficiently, and therefore allocate resources away from carboxylation toward other processes (Drake et al.

1997, Ainsworth & Rogers 2007;), one of which is growth. In one early example of this, Arctic tundra communities increased canopy level photosynthesis, although leaf-level acclimation occurred in the species of interest, *Eriophorum vaginatum* (Tissue & Oechel 1987). One theory as to why this occurred is increased tillering by *E. vaginatum*, increasing the photosynthetic surface of the plant. While individual leaves may be photosynthesizing at a lower rate, the plant as a whole may photosynthesize more.

In this study, the photosynthetic rate of *P. arundinacea* at growth CO₂ concentrations was not down regulated, but rather increased with nitrogen and with CO₂. Further, the maximum carboxylation rate of Rubisco (V_{cmax}) exhibited a significant response to nitrogen, but not to CO₂. This is not surprising as carbon assimilation is dependent on the nitrogen concentration of the leaf (Nowak et al. 2004), and nitrogen tends to increase in leaf tissue under nitrogen fertilization. However, because V_{cmax} did not respond to CO₂, *P. arundinacea* did not allocate resources away from carboxylation. Both findings indicate that acclimation did not occur over the 10 weeks of our experiments.

The response of *G. striata* to CO₂ and nitrogen was similar to that of *P. arundinacea* but not as strong, intimating a possible advantage for *P. arundinacea*. However, in an interesting corollary, research on native vs. invasive strains of *P. arundinacea* exhibited no difference in overall rate of photosynthesis (Brodersen et al. 2008). Rather, the authors predicted morphological traits, secondary compounds, and perhaps the patterns of physiology of the plants within a region (rather than the

region's mean photosynthetic response) were more important in predicting invasibility (Brodersen et al. 2008). While photosynthetic rate increased under elevated CO₂, and high nitrogen in this study, and V_{cmax} did not decrease under elevated CO₂, photosynthetic rate may not necessarily be a predictive variable of potential invasiveness in *P. arundinacea* in future conditions.

2.4.5 Fructan, Carbon, and Nitrogen Content in Rhizomes

2.4.5(a) *Phalaris arundinacea*

Percent carbon, the carbon-to-nitrogen ratio, and percent fructan in the rhizomes responded primarily to nitrogen, being lower in high nitrogen pots. This is consistent with several other studies, although none considered rhizomes specifically. Cheng and colleagues (2004) found that while an increase from 0 to 10 mM of nitrogen increased non-structural carbohydrates in the vines of a grape species, increases of 10 to 20 mM caused a subsequent decrease. Similar patterns were found in both apple and cranberry species (Cheng & Fuchigami 2002; Vanden Heuvel & Davenport 2006), and low nitrogen levels increased fructan by 700% in barley leaves (Wang & Tillberg 1996). A subsequent experiment by Wang and colleagues (2000) further supports the role nitrogen plays in carbon storage. They subjected barley to nitrogen starvation and then resupply. Fructan levels increased during nitrogen starvation but then decreased during resupply.

Because of their findings, Cheng and colleagues (2004) proposed that stored nitrogen may be more important for growth in the following season than carbon. However, Lipson and colleagues (1996) proposed a different conclusion. Using *Bistorta bistortoides*, a moderate growing, rhizomatous, perennial alpine grass, they found nitrogen fertilization to increase nitrogen storage in roots while decreasing sucrose storage, a finding similar to the ones cited above. However, they followed their study through to the subsequent season, and found that *B. bistortoides* used stored nitrogen for growth rather than taking up additional nitrogen. They propose that additional nitrogen is not taken up the following season because sucrose reserves are limited, and therefore there is less energy available for additional nitrogen uptake.

Our findings are interesting in that we consider overall carbon as well as carbon allocated for storage in the form of fructan. While both carbon and fructan decreased when grown under high nitrogen, fructan decreased substantially more (a 68% vs. 9% decrease). Furthermore, the rhizome-to-total-biomass ratio decreased for plants grown under high nitrogen (repetition 2), perhaps indicating a shift from carbon used for storage to carbon used for growth. As tiller numbers also increased with high nitrogen, the rhizomes may have spread and produced more tillers. The increase in the rhizome-to-root-biomass ratio in response to nitrogen corroborates this, and offers a second possibility. Under high nitrogen, *P. arundinacea* may shift belowground growth toward vegetative spread, however it may also preference storage over nutrient acquisition.

For the fructan-to-carbon ratio in the rhizomes, there was a significant CO₂-and-nitrogen interaction. A similar pattern occurred for percent fructan content in

repetition 2. This was due to an increase in the elevated CO₂, low nitrogen pots.

While we have not come across other studies that specifically demonstrate a shift from carbon for storage (fructan or starch) to carbon for structure, this pattern is also consistent with other studies. Barbehenn and colleagues (2004) found that sugars, starch, and fructans all increased in a series of grasses, with fructan concentrations increasing three fold, in response to elevated CO₂. Read and colleagues (1997) considered the effects of elevated CO₂ in combination with temperature, and found that *Pascopyrum smithii*, a C₃ grass, increased fructan concentration in its leaves when grown at its optimal temperature. Baxter and colleagues (1995) grew three perennial, montane grass species, *Agrostis capillaris*, *Poa alpina*, and *Festuca vivipara*, in outdoor open-top chambers. While the non-structural carbohydrates did not change in the roots of these species, aboveground non-structural carbohydrates increased in *P. alpina* and *F. vivipara*, the latter due primarily to fructan. In the study presented here, the fact that the highest percentage of fructan occurred in the elevated CO₂, low nitrogen pots, is also consistent with the aforementioned observation that when nitrogen is present, non-structural carbons decrease and are likely utilized toward growth.

2.4.5(b) *Glyceria striata*

While *P. arundinacea* responded to the two nitrogen treatments with an increase in percent carbon and a decrease in percent nitrogen in the low nitrogen pots, *G. striata*

responded significantly only with a decrease in nitrogen. We did not parse storage versus structural carbohydrates in *G. striata* as we did with *P. arundinacea*, but it may be that carbon storage is a strategy used more by *P. arundinacea* than *G. striata*. Nitrogen accumulation may be more important for *G. striata*. To support this suggestion, only *P. arundinacea* responded to CO₂ by decreasing its specific leaf area, perhaps due to an accumulation of non-structural carbohydrates in its leaves that increased their density. *Glyceria striata* showed no response.

Glyceria striata also demonstrated a significant CO₂-and-nitrogen interaction in the rhizome carbon-to-nitrogen ratio, due to a higher ratio in the elevated CO₂, low nitrogen pots. This increase was entirely because of a decrease in nitrogen. Nitrogen content tends to decrease under elevated CO₂, and several hypotheses have been proposed to explain this phenomenon (Taub & Wang 2008). One hypothesis is that tissue nitrogen is decreased because of dilution by accumulated carbon. That does not seem to be the case here. Taub and Wang discuss two other interesting hypotheses. First, nitrogen may decrease in plant tissues because nitrogen uptake by roots is lower when the demand for nitrogen is lower. This may occur under because of increased photosynthetic nitrogen use efficiency under elevated CO₂. Second, the ability of roots to take up nitrogen is diminished. This may occur when decreased transpiration due to decreased stomatal conductance lessens the nitrogen brought to the roots by bulk flow. When measuring gas exchange rates, *G. striata* did not show a significant response with stomatal conductance; however, as root biomass increased under elevated CO₂

regardless of nitrogen level, perhaps bulk flow decreased, triggering root growth to mine for nutrients.

2.4.6 Synthesis

2.4.6(a) *Phalaris arundinacea*

The responses of both *P. arundinacea* and *G. striata* to CO₂ primarily occurred in the first repetition, likely because there was adequate light to elicit a response. In the second repetition, any response noted was primarily due to nitrogen, perhaps because in the light-limited environment, nitrogen became important as plants allocated this resource toward light harvesting and away from carboxylation by Rubisco.

Overall, photosynthesis and the V_{cmax} of Rubisco increased, as expected, under high nitrogen, while only photosynthesis responded to CO₂. Because photosynthesis under growth CO₂ concentrations was higher in plants grown in elevated CO₂, and V_{cmax} did not decrease, *P. arundinacea* did not respond to CO₂ by down regulating its photosynthetic rate in the 10 weeks of our experiment.

Phalaris arundinacea, therefore, accumulated more carbon, responding to elevated CO₂ and high nitrogen by increasing whole-plant biomass. The increase in biomass due to nitrogen was in leaves, stems, and rhizomes, while the increase due to CO₂ occurred primarily in the stems and leaves. Leaf area increased in response to both environmental parameters, while tiller number responded only to nitrogen, indicating that CO₂ may contribute to size or density of tillers but not to number. As the response

in most of these growth parameters was strongest under elevated CO₂ and high nitrogen, elevated CO₂ may contribute to the invasive success of *P. arundinacea* by allowing it to increase its leaf area and perhaps shoot size to compete for light.

The belowground-to-aboveground biomass ratio decreased, predictably, from low to high nitrogen, but did not respond to CO₂. However, elevated CO₂ did lead to an increase in allocation of whole-plant biomass to stems, and a decrease in allocation to rhizomes when the plants were grown in high nitrogen. This perhaps indicates a shift from belowground to aboveground growth when resources are available.

Interestingly, while elevated CO₂ may lead to a slight shift in whole-plant biomass to aboveground growth when the plants are grown in high nitrogen, elevated CO₂ may, to some extent, negate the parallel effect belowground. The rhizome-to-root ratio increased under high nitrogen, but did so to a lesser degree under elevated CO₂. Elevated CO₂ may, therefore, cause *Phalaris arundinacea* to shift some of its belowground growth from storage or vegetative spread to nutrient acquisition to compensate for increased carbon in plant tissues. Further corroborating this, root biomass increased only under elevated CO₂ and in both nitrogen levels.

Stomatal aperture and therefore water use did not decrease under elevated CO₂, rather, water use increased. This is likely due to an increase in leaf area primarily in the high nitrogen treatments.

Phalaris arundinacea further responded to increased nitrogen by decreasing carbon in its rhizomes, with fructan, the storage carbon, decreasing to a greater degree than total carbon. Nitrogen in the rhizomes increased. Under high nutrient conditions,

then, *P. arundinacea* preferences current season growth, rather than carbon storage.

The opposite occurred in low nitrogen conditions under elevated CO₂. In that case, fructan increased to a greater extent than did total carbon, perhaps indicating that elevated CO₂ may improve the ability of *P. arundinacea* to re-sprout from rhizomes in the spring.

2.4.6(b) *Glyceria striata*

For the most part, *G. striata* responded to CO₂ and nitrogen similarly to *P. arundinacea*. *Glyceria striata* did not appear to acclimate to CO₂ by down regulating its rate of photosynthesis, at least in the 10 weeks of this experiment. The additional carbon assimilated under CO₂ and nitrogen lead to an increase in biomass, which was due primarily to leaves and stems. Like *P. arundinacea* some of this increase contributed to increased leaf area, but tiller number also responded to both treatments. It is possible then, that the CO₂ and nitrogen levels tested, may also increase the ability of *G. striata* to compete for shade by increasing its canopy volume. Further, as the biomass of leaves and stems increased to a greater degree in *G. striata* than they did in *P. arundinacea*, and they demonstrated a stronger response to CO₂, it may be that *G. striata* will better utilize elevated CO₂.

Glyceria striata differed from *P. arundinacea* in its allocation patterns. Like *P. arundinacea*, *G. striata* increased allocation to aboveground portions in response to high nitrogen, and decreased allocation belowground. However, it did not alter its

allocation in response to CO₂. *Glyceria striata*, then, may be less morphologically plastic, less capable of adjusting allocation in response to environmental variables.

Like *P. arundinacea*, stomatal aperture and therefore water use did not decrease under elevated CO₂. Instead, water use increased, likely because leaf area, as a surface for transpiration, also increased.

While both species responded to elevated CO₂ by decreasing their carbon-to-nitrogen ratio from low to high nitrogen treatments, this response was driven only by an increase in nitrogen in *G. striata*. Neither low nitrogen nor elevated CO₂ triggered an increase in stored carbons, as they did in *P. arundinacea*. Perhaps carbon storage is less important to *G. striata*. The fact that *G. striata* did not decrease its specific leaf area in response to elevated CO₂, further corroborates this. Specific leaf area may decrease in response to CO₂, because a build up of non-structural carbohydrates in the leaves increases their density.

2.5 IMPLICATIONS

2.5.1 *Phalaris arundinacea*

Overall, elevated CO₂ enhances the photosynthetic rate of plants, resulting in an increase in whole-plant biomass (Poorter & Navas 2003), a trend that is more pronounced in fast growing C₃ species. Although enhancement in photosynthesis diminishes after prolonged exposure to elevated CO₂ (Ainsworth & Rogers 2007), this

decrease is, in part, because plants divert nitrogen away from photosynthetic apparatus to mobilize stored carbon for growth of other organs (Gifford 2004). The effect of CO₂ on overall growth may be more important for species with indeterminate growth forms or large carbon sinks (Ziska 2008), because indeterminate growth may provide more sinks for available carbon. *Phalaris arundinacea* may be one such species, as it has been shown to rapidly take advantage of other available resources, often to a greater extent than native species (Lavergne & Molofsky 2004).

Poorter & Nagel (2000) argue that when resource allocation is being considered, it is best to consider more than above and belowground biomass. When leaves and stems are considered together, it is not possible to parse the effects of the very different roles that each organ plays. They suggest divisions of at least leaves, stems, and roots. Here, we propose that for perennial species, storage structures such as rhizomes, stolons, or tubers should also be considered separately as they play roles different than either stems or roots.

Polaris arundinacea is shade intolerant and is successful due to a synergy of disturbance, which removes the native canopy allowing *P. arundinacea* access to light, and fertilization (Kercher et al. 2007). In fact, planting willow stakes to provide rapid shade has been prescribed as a means by which to combat *P. arundinacea* invasion (Kim et al. 2006). It is the first repetition of the experiment, then, that gives a more accurate assessment of whether *P. arundinacea* will become more aggressive with increasing CO₂. Under the elevated CO₂ and high nitrogen levels used here, *P. arundinacea* increased its whole-plant biomass, with this increase being driven by the

biomass of stems and leaves. As, CO₂ did not elicit a response in tiller number, CO₂ may contribute to the size of each shoot rather than additional shoots. Leaf area, however, did increase with elevated CO₂. Ecologically, with its indeterminate growth, *P. arundinacea* may be able to utilize CO₂ when nitrogen is present to increase its canopy volume to shade out competitors. This is a strategy that has been noted previously with this species (Miller & Zedler 2003).

Interestingly, relative allocation to rhizomes decreased with elevated CO₂ and high nitrogen. This may indicate that when resources are available, *P. arundinacea* allocates more to aboveground growth for utilization in the current season. One study noted, for example, that *Vigna unguiculata* altered allocation to roots only enough to prevent water stress, otherwise the plant put more resources towards aboveground growth (Schulze et al. 1983 as cited in Percy et al. 1987). When resources are scarce, *P. arundinacea* may increase the resources stored in its rhizomes for use the following spring. Supporting these conclusions, *P. arundinacea* has exhibited a shift from aboveground growth in high nutrient environments to belowground growth in low nutrient environments in prior experiments, in both cases suppressing growth of other species (Green & Galatowitsch 2002).

If *P. arundinacea* does allocate more to storage when nutrients are scarce, elevated CO₂ may indeed improve the ability of *P. arundinacea* to sprout in the spring, as here we find that percent fructan concentrations and the ratio of fructan-to-total-carbon in the rhizomes increased in the elevated CO₂, low nitrogen treatment. However, further study is needed to determine whether this will occur.

Finally, root biomass did increase in response to elevated CO₂. While roots were a much smaller component of overall biomass than stems and leaves, an increase in root biomass has implications for competition for belowground resources as well as interactions with soil microorganisms (Green & Galatowitsch 2002; Kao-Kniffin & Balsler 2007).

2.5.2 *Glyceria striata*

Glyceria striata responded to a much greater extent than *P. arundinacea* to elevated CO₂, with the response in whole-plant biomass driven by more than 5- and 4-fold increases in stem and leaf biomass, respectively. This may indicate that CO₂ will increase the competitive advantage of *G. striata*; however, competition studies must be conducted to confirm this. In addition, it needs to be noted that while *P. arundinacea* is shade intolerant, *G. striata* can tolerate shade (USDA, NRCS 2009). It is possible that even in repetition 1, *P. arundinacea* was hindered by the lower light levels in the greenhouse (greenhouse glass transmits only about 85% of ambient light (Fred Hoyt, University of Washington Botanic Gardens, pers. comm.)). Outdoor studies, in high light, are needed to determine if *G. striata* will still respond to a greater degree than *P. arundinacea* under elevated CO₂.

Again, as with *P. arundinacea*, root biomass increased in response to elevated CO₂, and did so to a greater degree than *P. arundinacea* (117% versus 74%). This has

implications for competition for belowground resources as well as interactions with soil microorganisms (Green & Galatowitsch 2002; Kao-Kniffin & Balser 2007).

2.6 SUGGESTIONS FOR FUTURE STUDY

Throughout the study we noticed several anecdotal differences between the repetitions. In repetition 1, both species in both of the elevated CO₂ chambers flowered, whereas the plants in the ambient chambers did not. In addition, *G. striata* in the ambient chambers turned visibly yellow and began to brown. Yellowing became only slightly apparent in repetition 2 and no flowering occurred. While there is debate as to whether CO₂ alters phenology (Gifford 2004), adequate light levels, either related to photoperiod or photonflux density, are needed to move species through various life stages (Taiz & Zeiger 1998).

Because of the differences observed between repetition 1 and repetition 2, it is likely that we harvested at different life stages in each repetition. Fructan concentrations change in rhizomes throughout the course of a season (Day & Dixon 1985; Chalmers et al. 2005), and the assessment of differences in fructan provides only preliminary evidence that CO₂ may play a role in its accumulation. Further, our study does not demonstrate that fructans are important for growth. Indeed, nitrogen may be more important (Cheng et al. 2004), although some theorize that this may not be true when growth over multiple seasons is observed (Lipson et al. 1996). In addition to the competition study between *G. striata* and *P. arundinacea* mentioned above, a next step

would be to follow *P. arundinacea* grown under elevated CO₂ over subsequent seasons to determine whether changes in percent fructan content do promote faster regeneration in the spring.

LITERATURE CITED

- Ackerly, D., Dudley, S., Sultan, S., et al., 2000. The evolution of plant ecophysiological traits: Recent advances and future directions. *BIOSCIENCE*, 50(11), 979-995.
- Ainsworth, E., Leakey, A., Ort, D., et al., 2008. FACE-ing the facts: inconsistencies and interdependence among field, chamber and modeling studies of elevated [CO₂] impacts on crop yield and food supply. *NEW PHYTOLOGIST*, 179(1), 5-9.
- Ainsworth, E. & Long, S., 2005. What have we learned from 15 years of free-air CO₂ enrichment (FACE)? A meta-analytic review of the responses of photosynthesis, canopy. *NEW PHYTOLOGIST*, 165(2), 351-371.
- Ainsworth, E. & Rogers, A., 2007. The response of photosynthesis and stomatal conductance to rising [CO₂]: mechanisms and environmental interactions. *PLANT CELL AND ENVIRONMENT*, 30(3), 258-270.
- Barbehenn, R., Chen, Z., Karowe, D., et al., 2004. C-3 grasses have higher nutritional quality than C-4 grasses under ambient and elevated atmospheric CO₂. *GLOBAL CHANGE BIOLOGY*, 10(9), 1565-1575.
- Baxter, R., Bell, S., Sparks, T., et al., 1995. Effects of elevated CO₂ concentrations on 3 montane grass species: source metabolism and whole plant carbon partitioning. *JOURNAL OF EXPERIMENTAL BOTANY*, 46(289), 917-929.
- Bloor, J., Barthes, L. & Leadley, P., 2008. Effects of elevated CO₂ and N on tree-grass interactions: an experimental test using *Fraxinus excelsior* and *Dactylis glomerata*. *FUNCTIONAL ECOLOGY*, 22(3), 537-546.
- Bonilla-Warford, C. & Zedler, J., 2002. Potential for using native plant species in stormwater wetlands. *ENVIRONMENTAL MANAGEMENT*, 29(3), 385-394.
- Both, D. & Jackson, C., 1997. Urbanization of aquatic systems: Degredation thresholds, stormwater detection, and the limits of mitigation. *JOURNAL OF THE AMERICAN WATER RESOURCES ASSOCIATION*, 33(5), 1077-1090.
- Bradford, M., Shumacher, H., Catovsky, S., et al., 2007. Impacts of invasive plant species on riparian plant assemblages: interactions with elevated atmospheric carbon dioxide and nitrogen deposition. *OECOLOGIA*, 152(4), 791-803.

- Bradley, K. & Pregitzer, K., 2007. Ecosystem assembly and terrestrial carbon balance under elevated CO₂. *TRENDS IN ECOLOGY & EVOLUTION*, 22(10), 538-547.
- Brodersen, C., Lavergne, S. & Molofsky, J., 2008. Genetic variation in photosynthetic characteristics among invasive and native populations of reed canarygrass (*Phalaris arundinacea*). *BIOLOGICAL INVASIONS*, 10(8), 1317-1325.
- Bryant, J., Burrell, M. & Kruger, N., 1999. *PLANT CARBOHYDRATE BIOCHEMISTRY*, Oxford: Bios Scientific Publishers.
- Callaghan, T., Bjorn, L., Chernov, Y., et al., 2004. Effects of changes in climate on landscape and regional processes, and feedbacks to the climate system. *AMBIO*, 33(7), 459-468.
- Cannone, N., Diolaiuti, G., Guglielmin, M., et al., 2008. Accelerating climate change impacts on alpine glacier forefield ecosystems in the European Alps. *ECOLOGICAL APPLICATIONS*, 18(3), 637-648.
- Chalmers, J., Lidgett, A., Cummings, et al., 2005. Molecular genetics of fructan metabolism in perennial ryegrass. *PLANT BIOTECHNOLOGY JOURNAL*, 3(5), 459-474.
- Cheng, L., Xia, G. & Bates, T., 2004. Growth and fruiting of young 'Concord' grapevines in relation to reserve nitrogen and carbohydrates. *JOURNAL OF THE AMERICAN SOCIETY FOR HORTICULTURAL SCIENCE*, 129(5), 660-666.
- Cheng, L. & Fuchigami, L., 2002. Growth of young apple trees in relation to reserve nitrogen and carbohydrates. *TREE PHYSIOLOGY*, 22, 1297-1303.
- Comes, R., 1971. *The Biology and Control of Reed Canarygrass (Phalaris arundinacea L.) on Irrigation Ditchbanks*. Oregon State University: Doctoral Dissertation.
- Cowan, J. & Reekie, E., 2008. Effects of elevated CO₂ on intra-specific competition in *Sinapis alba*: an examination of the role of growth responses to red : far-red ratio. *PLANT BIOLOGY*, 10(2), 202-210.
- Craft, C., Krull, K. & Graham, S., 2007. Ecological indicators of nutrient enrichment, freshwater wetlands, Midwestern United States (US). *ECOLOGICAL INDICATORS*, 7(4), 733-750.

- Day, P. & Dixon, R., 1985. *Biochemistry of Storage Carbohydrates in Green Plants*, London: Academic Press.
- Drake, B., 1992. A field-study of the effects of elevated CO₂ on ecosystem processes in a Chesapeake Bay wetland. *AUSTRALIAN JOURNAL OF BOTANY*, 40(4-5), 579-595.
- Drake, B., Gonzalez-Meler, M. & Long, S., 1997. More efficient plants: A consequence of rising atmospheric CO₂? *ANNUAL REVIEW OF PLANT PHYSIOLOGY AND PLANT MOLECULAR BIOLOGY*, 48, 609-639.
- Dupont, 2009. Dupont Teijin Films. Available at:
<http://www.dupontteijinfilms.com/FilmEnterprise/ProductLocatorResults.asp?Version=US> [Accessed July 10, 2009].
- DuPont, 2009. DuPont Teflon FEP Film. Available at:
http://www2.dupont.com/Teflon_Industrial/en_US/products/product_by_name/teflon_fep/index.html [Accessed May 14, 2009].
- Eissenstat, D., Wells, C., Yanai, R., et al., 2000. Building roots in a changing environment: implications for root longevity. *NEW PHYTOLOGIST*, 147(1), 33-42.
- Garcia-Amorena, I., Wagner, F., van Hoof, T., et al., 2006. Stomatal responses in deciduous oaks from southern Europe to the anthropogenic atmospheric CO₂ increase; refining the stomatal-based CO₂ proxy. *REVIEW OF PALAEOBOTANY AND PALYNOLOGY*, 141(3-4), 303-312.
- George, K., Ziska, L., Bunce, J., et al., 2007. Elevated atmospheric CO₂ concentration and temperature across an urban-rural transect. *ATMOSPHERIC ENVIRONMENT*, 41(35), 7654-7665.
- Gifford, R., 2004. The CO₂ fertilising effect - does it occur in the real world? The International Free Air CO₂ Enrichment (FACE) Workshop: Short- and long-term effects of elevated atmospheric CO₂ on managed ecosystems, Ascona, Switzerland, March 2004. *NEW PHYTOLOGIST*, 163(2), 221-225.
- Goudriaan, J., 1987. The Biosphere as a Driving Force in the Global Carbon-Cycle. *NETHERLANDS JOURNAL OF AGRICULTURAL SCIENCE*, 35(2), 177-187.
- Green, E. & Galatowitsch, S., 2002. Effects of *Phalaris arundinacea* and nitrate-N addition on the establishment of wetland plant communities. *JOURNAL OF APPLIED ECOLOGY*, 39(1), 134-144.

- Gregg, J., 2009. DOE Program for Ecosystem Research. *US Department of Energy: Program for Ecosystem Research*. Available at: <http://per.ornl.gov/Gregg.html> [Accessed July 10, 2009].
- Grotkopp, E. & Rejmanek, M., 2007. High seedling relative growth rate and specific leaf area are traits of invasive species: Phylogenetically independent contrasts of woody angiosperms. *AMERICAN JOURNAL OF BOTANY*, 94(4), 526-532.
- Hackman, N., 2009. *Measuring Plant Responses to CO2 Concentrations in the Urban Environment of Seattle, WA*. Master's Thesis. University of Washington.
- He, J., Wolfe-Bellin, K. & Bazzaz, F., 2005. Leaf-level physiology, biomass, and reproduction of *Phytolacca americana* under conditions of elevated CO2 and altered temperature regimes. *INTERNATIONAL JOURNAL OF PLANT SCIENCES*, 166(4), 615-622.
- Herr-Turoff, A. & Zedler, J., 2007. Does morphological plasticity of the *Phalaris arundinacea* canopy increase invasiveness? *PLANT ECOLOGY*, 193(2), 265-277.
- IPCC, 2007. *Climate Change 2007: The Physical Science Basis. Contribution of Working Group I to the Fourth Assessment Report of the Intergovernmental Panel on Climate Change*, Available at: <http://www.ipcc.ch/ipccreports/ar4-syr.htm> [Accessed May 4, 2009].
- Kao-Kniffin, J. & Balsler, T., 2007. Elevated CO2 differentially alters belowground plant and soil microbial community structure in reed canary grass-invaded experimental wetlands. *SOIL BIOLOGY & BIOCHEMISTRY*, 39(2), 517-525.
- Kercher, S., Herr-Turoff, A. & Zedler, J., 2007. Understanding invasion as a process: the case of *Phalaris arundinacea* in wet prairies. *BIOLOGICAL INVASIONS*, 9(6), 657-665.
- Kim, K., Ewing, K. & Giblin, D., 2006. Controlling *Phalaris arundinacea* (reed canarygrass) with live willow stakes: A density-dependent response. *ECOLOGICAL ENGINEERING*, 27(3), 219-227.
- Lambers, H., Chapin, F.I. & Pons, T., 2006. *PLANT PHYSIOLOGICAL ECOLOGY*, Springer Science + Business Media, LLC.
- Lavergne, S. & Molofsky, J., 2007. Increased genetic variation and evolutionary potential drive the success of an invasive grass. *PROCEEDINGS OF THE NATIONAL ACADEMY OF SCIENCES OF THE UNITED STATES OF AMERICA*, 104(10), 3883-3888.

- Lavergne, S. & Molofsky, J., 2004. Reed canary grass (*Phalaris arundinacea*) as a biological model in the study of plant invasions. *CRITICAL REVIEWS IN PLANT SCIENCES*, 23(5), 415-429.
- Lindig-Cisneros, R. & Zedler, J., 2001. Effect of light on seed germination in *Phalaris arundinacea* L. (reed canary grass). *PLANT ECOLOGY*, 155(1), 75-78.
- Lipson, D., Bowman, W. & Monson, R., 1996. Luxury uptake and storage of nitrogen in the rhizomatous alpine herb, *Bistorta bistortoides*. *ECOLOGY*, 77(4), 1277-1285.
- Long, S., Ainsworth, E., Leakey, A., et al., 2006. Food for thought: Lower-than-expected crop yield stimulation with rising CO₂ concentrations. *SCIENCE*, 312(5782), 1918-1921.
- Maurer, D. & Zedler, J., 2002. Differential invasion of a wetland grass explained by tests of nutrients and light availability on establishment and clonal growth. *OECOLOGIA*, 131(2), 279-288.
- Miller, R. & Zedler, J., 2003. Responses of native and invasive wetland plants to hydroperiod and water depth. *PLANT ECOLOGY*, 167(1), 57-69.
- Nagel, J. & Griffin, K., 2004. Can gas-exchange characteristics help explain the invasive success of *Lythrum salicaria*? *BIOLOGICAL INVASIONS*, 6(1), 101-111.
- Nagel, J. & Griffin, K., 2001. Construction cost and invasive potential: Comparing *Lythrum salicaria* (Lythraceae) with co-occurring native species along pond banks. *AMERICAN JOURNAL OF BOTANY*, 88(12), 2252-2258.
- Nagel, J., Wang, X., Lewis, J., et al., 2005. Atmospheric CO₂ enrichment alters energy assimilation, investment and allocation in *Xanthium strumarium*. *NEW PHYTOLOGIST*, 166(2), 513-523.
- Nowak, R.S., Ellsworth, D.S. & Smith, S.D., 2004. Functional responses of plants to elevated atmospheric CO₂: do photosynthetic and productivity data from FACE experiments support early predictions? *NEW PHYTOLOGIST*, 162(2), 253-280.
- Pattison, R., Goldstein, G. & Ares, A., 1998. Growth, biomass allocation and photosynthesis of invasive and native Hawaiian rainforest species. *OECOLOGIA*, 117(4), 449-459.

- Pearcy, R., Bjorkman, O., Caldwell, M., et al., 1987. Carbon gain by plants in natural environments. *BIOSCIENCE*, 37(1), 21-29.
- Poorter, H. & Nagel, O., 2000. The role of biomass allocation in the growth response of plants to different levels of light, CO₂, nutrients and water: a quantitative review. *AUSTRALIAN JOURNAL OF PLANT PHYSIOLOGY*, 27(6), 595-607.
- Poorter, H. & Navas, M., 2003. Plant growth and competition at elevated CO₂: on winners, losers and functional groups. *NEW PHYTOLOGIST*, 157(2), 175-198.
- Raper, C. & Peedin, G., 1978. Photosynthetic rate during steady-state growth as influenced by carbon-dioxide concentration. *BOTANICAL GAZETTE*, 139(2), 147-149.
- Rasse, D., Peresta, G. & Drake, B., 2005. Seventeen years of elevated CO₂ exposure in a Chesapeake Bay Wetland: sustained but contrasting responses of plant growth and CO₂ uptake. *GLOBAL CHANGE BIOLOGY*, 11(3), 369-377.
- Read, J., Morgan, J., Chatterton, N., et al., 1997. Gas exchange and carbohydrate and nitrogen concentrations in leaves of *Paspopyrum smithii* (C-3) and *Bonteloua gracilis* (C-4) at different carbon dioxide concentrations and temperatures. *ANNALS OF BOTANY*, 79(2), 197-206.
- Reekie, E. MacDougall, C., Wong, I., et al., 1998. Effect of sink size on growth response to elevated atmospheric CO₂ within the genus *Brassica*. *CANADIAN JOURNAL OF BOTANY-REVUE CANADIENNE DE BOTANIQUE*, 76(5), 829-835.
- Reich, P., Walters, M. & Ellsworth, D., 1997. From tropics to tundra: Global convergence in plant functioning. *PROCEEDINGS OF THE NATIONAL ACADEMY OF SCIENCES OF THE UNITED STATES OF*, 94(25), 13730-13734.
- Reichard, S. & Hamilton, C., 1997. Predicting invasions of woody plants introduced into North America. *CONSERVATION BIOLOGY*, 11(1), 193-203.
- Rout, M. & Chrzanowski, T., 2009. The invasive *Sorghum halepense* harbors endophytic N₂-fixing bacteria and alters soil biogeochemistry. *PLANT AND SOIL*, 315(1-2), 163-172.
- Schooler, S., McEvoy, P. & Coombs, E., 2006. Negative per capita effects of purple loosestrife and reed canary grass on plant diversity of wetland communities. *DIVERSITY AND DISTRIBUTIONS*, 12(4), 351-363.

- Seebacher, L., 2008. *Phalaris arundinacea control and riparian restoration within agricultural watercourses in King county, Washington*. Doctoral Dissertation, University of Washington.
- Sharkey, T., Bernacchi, C., Farquhar, G., et al., 2007. Fitting photosynthetic carbon dioxide response curves for C-3 leaves. *PLANT CELL AND ENVIRONMENT*, 30(9), 1035-1040.
- Shaver, G., Street, L., Rastetter, E., et al., 2007. Functional convergence in regulation of net CO₂ flux in heterogeneous tundra landscapes in Alaska and Sweden. *JOURNAL OF ECOLOGY*, 95(4), 802-817.
- Smith, S., Huxman, T., Zitzer, S., et al., 2000. Elevated CO₂ increases productivity and invasive species success in an arid ecosystem. *NATURE*, 408(6808), 79-82.
- Smith, D., 1968. Classification of several native North American grasses as starch or fructosan accumulators in relation to taxonomy. *JOURNAL OF THE BRITISH GRASSLAND SOCIETY*, 23, 306-309.
- Stinson, K., Tranz, J., Petzold, J., et al., 2006. Architectural and physiological mechanisms of reduced size inequality in CO₂-enriched stands of common ragweed (*Ambrosia artemisiifolia*). *GLOBAL CHANGE BIOLOGY*, 12(9), 1680-1689.
- Stock, W. & Evans, J., 2006. Effects of water availability, nitrogen supply and atmospheric CO₂ concentrations on plant nitrogen natural abundance values. *FUNCTIONAL PLANT BIOLOGY*, 33(3), 219-227.
- Suarez, N., 2003. Leaf longevity, construction, and maintenance costs of three mangrove species under field conditions. *PHOTOSYNTHETICA*, 41(3), 373-381.
- Taiz, L. & Zeiger, E., 1998. *PLANT PHYSIOLOGY* 2nd ed., Sunderland, Massachusetts: Sinaur Associates, Inc.
- Tamura, Y. & Moriyama, M., 2001. Nonstructural carbohydrate reserves in roots and the ability of temperate perennial grasses to overwinter in early growth stages. *PLANT PRODUCTION SCIENCE*, 4, 56-61.
- Taub, D. & Wang, X., 2008. Why are Nitrogen Concentrations in Plant Tissues Lower under Elevated CO₂? A Critical Examination of the Hypotheses. *JOURNAL OF INTEGRATIVE PLANT BIOLOGY*, 50(11), 1365-1374.

- Tissue, D. & Oechel, W., 1987. Response of *Eriophorum vaginatum* to elevated CO₂ and temperature in the Alaskan tussock tundra. *ECOLOGY*, 68(2), 401-410.
- Tronsmo, A., Kobro, G., Morgenlie, S., and Flengsrud, R.. 1993. Carbohydrate content and glycosidase activities following cold hardening in 2 grass species. *PHYSIOLOGIA PANTARUM*. 88: 689-695.
- Tubiello, F., Amthor, J., Boote, K., et al., 2007. Crop response to elevated CO₂ and world food supply - A comment on "Food for Thought..." by Long et al., *Science* 312 : 1918-1921, 2006. *EUROPEAN JOURNAL OF AGRONOMY*, 26(3), 215-223.
- USDA, NRCS, 2009. *The PLANTS Database*. Available at: <http://plants.usda.gov> [Accessed May 21, 2009].
- Vanden Heuvel, J. & Davenport, J., 2006. The impact of nitrogen application on nonstructural carbohydrate production in cranberry leaves. *HORTSCIENCE*, 41(4), 124 .
- Vitousek, P., Aber, J., Howarth, R., et al., 1997. Human alteration of the global nitrogen cycle: Sources and consequences. *ECOLOGICAL APPLICATIONS*, 7(3), 737-750.
- Wang, C. & Tillberg, J., 1996. Effects of nitrogen deficiency on accumulation of fructan and fructan metabolizing enzyme activities in sink and source leaves of barley (*hordeum vulgare*) . *PHYSIOLOGIA PLANTARUM*, 97, 339-345.
- Wang, C., Van den Ende, W. & Tillberg, J., 2000. Fructan accumulation induced by nitrogen efficiency in barley leaves correlates with the level of sucrose: fructan 6-fructosyltransferase mRNA. *Planta*, 211, 701-707.
- Wolfe, D., Gifford, R., Hilbert, D., et al., 1998. Integration of photosynthetic acclimation to CO₂ at the whole-plant level. *GLOBAL CHANGE BIOLOGY*, 4(8), 879-893.
- Zedler, J. & Kercher, S., 2004. Causes and consequences of invasive plants in wetlands: Opportunities, opportunists, and outcomes. *CRITICAL REVIEWS IN PLANT SCIENCES*, 23(5), 431-452.
- Zedler, J. & Kercher, S., 2005. Wetland resources: Status, trends, ecosystem services, and restorability. *ANNUAL REVIEW OF ENVIRONMENT AND RESOURCES*, 30, 39-74.

- Ziska, L., 2003. Evaluation of the growth response of six invasive species to past, present and future atmospheric carbon dioxide. *JOURNAL OF EXPERIMENTAL BOTANY*, 54(381), 395-404.
- Ziska, L., 2008. Three-year field evaluation of early and late 20th century spring wheat cultivars to projected increases in atmospheric carbon dioxide. *FIELD CROPS RESEARCH*, 108(1), 54-59.
- Ziska, L., George, K. & Frenz, D., 2007. Establishment and persistence of common ragweed (*Ambrosia artemisiifolia* L.) in disturbed soil as a function of an urban-rural macro-environment. *GLOBAL CHANGE BIOLOGY*, 13(1), 266-274.

BIBLIOGRAPHY

- Ackerly, D., Dudley, S., Sultan, S., et al., 2000. The evolution of plant ecophysiological traits: Recent advances and future directions. *BIOSCIENCE*, 50(11), 979-995.
- Aerts, R., 2009. Nitrogen supply effects on leaf dynamics and nutrient input into the soil of plant species in a sub-arctic tundra ecosystem. *POLAR BIOLOGY*, 32(2), 207-214.
- Ainsworth, E., 2008. Rice production in a changing climate: a meta-analysis of responses to elevated carbon dioxide and elevated ozone concentration. *GLOBAL CHANGE BIOLOGY*, 14(7), 1642-1650.
- Ainsworth, E., Leakey, A., Ort, D., et al., 2008. FACE-ing the facts: inconsistencies and interdependence among field, chamber and modeling studies of elevated [CO₂] impacts on crop yield and food supply. *NEW PHYTOLOGIST*, 179(1), 5-9.
- Ainsworth, E. & Long, S., 2005. What have we learned from 15 years of free-air CO₂ enrichment (FACE)? A meta-analytic review of the responses of photosynthesis, canopy. *NEW PHYTOLOGIST*, 165(2), 351-371.
- Ainsworth, E. & Rogers, A., 2007. The response of photosynthesis and stomatal conductance to rising [CO₂]: mechanisms and environmental interactions. *PLANT CELL AND ENVIRONMENT*, 30(3), 258-270.
- Aranjuelo, I., Perez, P., Hernandez, L., et al., 2005. The response of nodulated alfalfa to water supply, temperature and elevated CO₂: photosynthetic downregulation. *PHYSIOLOGIA PLANTARUM*, 123(3), 348-358.
- Barbehenn, R., Chen, Z., Karowe, D., et al., 2004. C-3 grasses have higher nutritional quality than C-4 grasses under ambient and elevated atmospheric CO₂. *GLOBAL CHANGE BIOLOGY*, 10(9), 1565-1575.
- Baxter, R., Bell, S., Sparks, T., et al., 1995. Effects of elevated CO₂ concentrations on 3 montane grass species: source metabolism and whole plant carbon partitioning. *JOURNAL OF EXPERIMENTAL BOTANY*, 46(289), 917-929.
- Baxter, R. & Farrar, J., 1999. Export of carbon from leaf blades of *Poa alpina* L-at elevated CO₂ and two nutrient regimes. *JOURNAL OF EXPERIMENTAL BOTANY*, 50(336), 1215-1221.

- Belote, R., Weltzin, J. & Norby, R., 2004. Response of an understory plant community to elevated [CO₂] depends on differential responses of dominant invasive species and is mediated by soil water availability. *NEW PHYTOLOGIST*, 161(3), 827-835.
- Berendse, F. & Moller, F., 2009. Effects of competition on root-shoot allocation in *Plantago lanceolata* L.: adaptive plasticity or ontogenetic drift? *PLANT ECOLOGY*, 201(2), 567-573.
- Bernacchi, C., Coleman, J., Bazzazz., et al., 2000. Biomass allocation in old-field annual species grown in elevated CO₂ environments: no evidence for optimal partitioning. *GLOBAL CHANGE BIOLOGY*, 6(7), 855-863.
- Bloor, J., Barthes, L. & Leadley, P., 2008. Effects of elevated CO₂ and N on tree-grass interactions: an experimental test using *Fraxinus excelsior* and *Dactylis glomerata*. *FUNCTIONAL ECOLOGY*, 22(3), 537-546.
- Bonilla-Warford, C. & Zedler, J., 2002. Potential for using native plant species in stormwater wetlands. *ENVIRONMENTAL MANAGEMENT*, 29(3), 385-394.
- Both, D. & Jackson, C., 1997. Urbanization of aquatic systems: Degredation thresholds, stormwater detection, and the limits of mitigation. *Journal of the American Water Resources Association*, 33(5), 1077-1090.
- Bradford, M., Shumacher, H., Catovsky, S., et al., 2007. Impacts of invasive plant species on riparian plant assemblages: interactions with elevated atmospheric carbon dioxide and nitrogen deposition. *OECOLOGIA*, 152(4), 791-803.
- Bradley, K. & Pregitzer, K., 2007. Ecosystem assembly and terrestrial carbon balance under elevated CO₂. *TRENDS IN ECOLOGY & EVOLUTION*, 22(10), 538-547.
- Brodersen, C., Lavergne, S. & Molofsky, J., 2008. Genetic variation in photosynthetic characteristics among invasive and native populations of reed canarygrass (*Phalaris arundinacea*). *BIOLOGICAL INVASIONS*, 10(8), 1317-1325.
- Bryant, J., Burrell, M. & Kruger, N., 1999. *Plant Carbohydrate Biochemistry*, Oxford: Bios Scientific Publishers.
- Cai, Z., Porrter, L., Han., Q et al., 2008. Effects of light and nutrients on seedlings of tropical *Bauhinia* lianas and trees. *TREE PHYSIOLOGY*, 28(8), 1277-1285.

- Callaghan, T., Bjorn, L., Chernov, Y., et al., 2004. Effects of changes in climate on landscape and regional processes, and feedbacks to the climate system. *AMBIO*, 33(7), 459-468.
- Cannone, N., Diolaiuti, G., Guglielmin, M., et al., 2008. Accelerating climate change impacts on alpine glacier forefield ecosystems in the European Alps. *ECOLOGICAL APPLICATIONS*, 18(3), 637-648.
- Catovsky, S. & Bazzaz, F., 1999. Elevated CO₂ influences the responses of two birch species to soil moisture: implications for forest community structure. *GLOBAL CHANGE BIOLOGY*, 5(5), 507-518.
- Chalmers, J., Lidgett, A., Cummings., et al., 2005. Molecular genetics of fructan metabolism in perennial ryegrass. *PLANT BIOTECHNOLOGY JOURNAL*, 3(5), 459-474.
- Cheng, L., Xia, G. & Bates, T., 2004. Growth and fruiting of young 'Concord' grapevines in relation to reserve nitrogen and carbohydrates. *JOURNAL OF THE AMERICAN SOCIETY FOR HORTICULTURAL SCIENCE*, 129(5), 660-666.
- Cheng, L., Xia, G. & Bates, T., 2004. Growth and fruiting of young 'Concord' grapevines in relation to reserve nitrogen and carbohydrates. *JOURNAL OF THE AMERICAN SOCIETY FOR HORTICULTURAL SCIENCE*, 129(5), 660-666.
- Cheng, L. & Fuchigami, L., 2002. Growth of young apple trees in relation to reserve nitrogen and carbohydrates. *Tree Physiology*, 22, 1297-1303.
- Comes, R., 1971. *The Biology and Control of Reed Canarygrass (Phalaris arundinacea L.) on Irrigation Ditchbanks.* , Oregon State University: Doctoral Dissertation.
- Cowan, J. & Reekie, E., 2008. Effects of elevated CO₂ on intra-specific competition in *Sinapis alba*: an examination of the role of growth responses to red : far-red ratio. *PLANT BIOLOGY*, 10(2), 202-210.
- Craft, C., Krull, K. & Graham, S., 2007. Ecological indicators of nutrient enrichment, freshwater wetlands, Midwestern United States (US). *ECOLOGICAL INDICATORS*, 7(4), 733-750.
- Day, P. & Dixon, R., 1985. *Biochemistry of Storage Carbohydrates in Green Plants*, London: Academic Press.

- Delisle, F., Lavoie, C., Jean, M., et al., 2003. Reconstructing the spread of invasive plants: taking into account biases associated with herbarium specimens. *JOURNAL OF BIOGEOGRAPHY*, 30(7), 1033-1042.
- Drake, B. 1992. A field study of the effects of elevated CO₂ on ecosystem processes in a Chesapeake Bay wetland. *AUSTRALIAN JOURNAL OF BOTANY*, 40(4-5), 579-595.
- Drake, B., Gonzalez-Meler, M. & Long, S., 1997. More efficient plants: A consequence of rising atmospheric CO₂? *ANNUAL REVIEW OF PLANT PHYSIOLOGY AND PLANT MOLECULAR BIOLOGY*, 48, 609-639.
- Dupont, 2009a. Dupont Teijin Films. Available at:
<http://www.dupontteijinfilms.com/FilmEnterprise/ProductLocatorResults.asp?Version=US> [Accessed July 10, 2009].
- DuPont, 2009b. DuPont Teflon FEP Film. Available at:
http://www2.dupont.com/Teflon_Industrial/en_US/products/product_by_name/teflon_fep/index.html [Accessed May 14, 2009].
- Edwards, K., Cizkova, H., Zemanova, K., et al., 2006. Plant growth and microbial processes in a constructed wetland planted with *Phalaris arundinacea*. *ECOLOGICAL ENGINEERING*, 27(2), 153-165.
- Eissenstat, D., Wells, Yanai, R., et al., 2000. Building roots in a changing environment: implications for root longevity. *NEW PHYTOLOGIST*, 147(1), 33-42.
- Feng, Y., 2008. Photosynthesis, nitrogen allocation and specific leaf area in invasive *Eupatorium adenophorum* and native *Eupatorium japonicum* grown at different irradiances. *PHYSIOLOGIA PLANTARUM*, 133(2), 318-326.
- Feng, Y. & Fu, G., 2008. Nitrogen allocation, partitioning and use efficiency in three invasive plant species in comparison with their native congeners. *BIOLOGICAL INVASIONS*, 10(6), 891-902.
- Feng, Y., Fu, G. & Zheng, Y., 2008. Specific leaf area relates to the differences in leaf construction cost, photosynthesis, nitrogen allocation, and use efficiencies between invasive and noninvasive alien congeners. *PLANTA*, 228(3), 383-390.
- Garcia-Amorena, I., Wagner, F., van Hoof, T., et al., 2006. Stomatal responses in deciduous oaks from southern Europe to the anthropogenic atmospheric CO₂ increase; refining the stomatal-based CO₂ proxy. *REVIEW OF PALAEOBOTANY AND PALYNOLOGY*, 141(3-4), 303-312.

- George, K., Ziska, L., Bunce, J., et al., 2007. Elevated atmospheric CO₂ concentration and temperature across an urban-rural transect. *ATMOSPHERIC ENVIRONMENT*, 41(35), 7654-7665.
- Gielen, B., De Boeck, H., Lemmens, C., et al., 2005. Grassland species will not necessarily benefit from future elevated air temperatures: a chlorophyll fluorescence approach to study autumn physiology. *PHYSIOLOGIA PLANTARUM*, 125(1), 52-63.
- Gifford, R., 2004. The CO₂ fertilising effect - does it occur in the real world? The International Free Air CO₂ Enrichment (FACE) Workshop: Short- and long-term effects of elevated atmospheric CO₂ on managed ecosystems, Ascona, Switzerland, March 2004. *NEW PHYTOLOGIST*, 163(2), 221-225.
- Gifford, R., 1995. Whole plant respiration and photosynthesis of wheat under increased CO₂ concentration and temperature: Long-term vs short-term distinctions for modelling. *GLOBAL CHANGE BIOLOGY*, 1(6), 385-396.
- Goudriaan, J., 1987. The Biosphere as a Driving Force in the Global Carbon-Cycle. *NETHERLANDS JOURNAL OF AGRICULTURAL SCIENCE*, 35(2), 177-187.
- Green, E. & Galatowitsch, S., 2002. Effects of *Phalaris arundinacea* and nitrate-N addition on the establishment of wetland plant communities. *JOURNAL OF APPLIED ECOLOGY*, 39(1), 134-144.
- Gregg, J., 2009. DOE Program for Ecosystem Research. *US Department of Energy: Program for Ecosystem Research*. Available at: <http://per.ornl.gov/Gregg.html> [Accessed July 10, 2009].
- Grotkopp, E. & Rejmanek, M., 2007. High seedling relative growth rate and specific leaf area are traits of invasive species: Phylogenetically independent contrasts of woody angiosperms. *AMERICAN JOURNAL OF BOTANY*, 94(4), 526-532.
- Hackman, N., 2009. *Measuring Plant Responses to CO₂ Concentrations in the Urban Environment of Seattle, WA*. Master's Thesis. University of Washington.
- He, J., Wolfe-Bellin, K. & Bazzaz, F., 2005. Leaf-level physiology, biomass, and reproduction of *Phytolacca americana* under conditions of elevated CO₂ and altered temperature regimes. *INTERNATIONAL JOURNAL OF PLANT SCIENCES*, 166(4), 615-622.
- Hebeisen, T., Luscher, A., Zanetti, S., et al., 1997. Growth response of *Trifolium repens* L and *Lolium perenne* L as monocultures and bi-species mixture to free

- air CO₂ enrichment and management. *GLOBAL CHANGE BIOLOGY*, 3(2), 149-160.
- Hely, S. & Roxburgh, S., 2005. The interactive effects of elevated CO₂, temperature and initial size on growth and competition between a native C-3 and an invasive C-3 grass. *PLANT ECOLOGY*, 177(1), 85-98.
- Herr-Turoff, A. & Zedler, J., 2007. Does morphological plasticity of the *Phalaris arundinacea* canopy increase invasiveness? *PLANT ECOLOGY*, 193(2), 265-277.
- IPCC, 2007. *Climate Change 2007: The Physical Science Basis. Contribution of Working Group I to the Fourth Assessment Report of the Intergovernmental Panel on Climate Change*, Available at: <http://www.ipcc.ch/ipccreports/ar4-syr.htm> [Accessed May 4, 2009].
- Jifon, J. & Wolfe, D., 2005. High temperature-induced sink limitation alters growth and photosynthetic acclimation to elevated CO₂ in bean (*Phaseolus vulgaris* L.). *JOURNAL OF THE AMERICAN SOCIETY FOR HORTICULTURAL SCIENCE*, 130(4), 515-520.
- Jumpponen, A., Mulder, C., Huss-Danell, K., et al., 2005. Winners and losers in herbaceous plant communities: insights from foliar carbon isotope composition in monocultures and mixtures. *JOURNAL OF ECOLOGY*, 93(6), 1136-1147.
- Kao-Kniffin, J. & Balsler, T., 2007. Elevated CO₂ differentially alters belowground plant and soil microbial community structure in reed canary grass-invaded experimental wetlands. *SOIL BIOLOGY & BIOCHEMISTRY*, 39(2), 517-525.
- Kercher, S., Carpenter, Q. & Zedler, J., 2004. Interrelationships of hydrologic disturbance, reed canary grass (*Phalaris arundinacea* L.), and native plants in Wisconsin wet meadows. *NATURAL AREAS JOURNAL*, 24(4), 316-325.
- Kercher, S., Herr-Turoff, A. & Zedler, J., 2007. Understanding invasion as a process: the case of *Phalaris arundinacea* in wet prairies. *BIOLOGICAL INVASIONS*, 9(6), 657-665.
- Kercher, S. & Zedler, J., 2004. Flood tolerance in wetland angiosperms: a comparison of invasive and noninvasive species. *AQUATIC BOTANY*, 80(2), 89-102.
- Kim, K., Ewing, K. & Giblin, D., 2006. Controlling *Phalaris arundinacea* (reed canarygrass) with live willow stakes: A density-dependent response. *ECOLOGICAL ENGINEERING*, 27(3), 219-227.

- Kirschbaum, M., 2004. Direct and indirect climate change effects on photosynthesis and transpiration. *PLANT BIOLOGY*, 6(3), 242-253.
- Korner, C., 2003. Carbon limitation in trees. *JOURNAL OF ECOLOGY*, 91(1), 4-17.
- Korner, C., 2006. Plant CO₂ responses: an issue of definition, time and resource supply. *NEW PHYTOLOGIST*, 172(3), 393-411.
- Lambers, H., Chapin, F.I. & Pons, T., 2006. *Plant Physiological Ecology*, Springer Science + Business Media, LLC.
- Lavergne, S. & Molofsky, J., 2007. Increased genetic variation and evolutionary potential drive the success of an invasive grass. *PROCEEDINGS OF THE NATIONAL ACADEMY OF SCIENCES OF THE UNITED STATES OF AMERICA*, 104(10), 3883-3888.
- Lavergne, S. & Molofsky, J., 2004. Reed canary grass (*Phalaris arundinacea*) as a biological model in the study of plant invasions. *CRITICAL REVIEWS IN PLANT SCIENCES*, 23(5), 415-429.
- Lavoie, C., Dufresne, C. & Delisle, F., 2005. The spread of reed canarygrass (*Phalaris arundinacea*) in Quebec: A spatio-temporal perspective. *ECOSCIENCE*, 12(3), 366-375.
- Lavoie, C., Jean, M., Deslisle, F., et al., 2003. Exotic plant species of the St Lawrence River wetlands: a spatial and historical analysis. *JOURNAL OF BIOGEOGRAPHY*, 30(4), 537-549.
- Lemmens, C., De Boeck, H., Gielen, B., et al., 2006. End-of-season effects of elevated temperature on ecophysiological processes of grassland species at different species richness levels. *ENVIRONMENTAL AND EXPERIMENTAL BOTANY*, 56(3), 245-254.
- Lilley, J., Bolger, T. & Gifford, R., 2001. Productivity of *Trifolium subterraneum* and *Phalaris aquatica* under warmer, high CO₂ conditions. *NEW PHYTOLOGIST*, 150(2), 371-383.
- Lilley, J., Bolger, T., Peoples, M. et al., 2001. Nutritive value and the nitrogen dynamics of *Trifolium subterraneum* and *Phalaris aquatica* under warmer, high CO₂ conditions. *NEW PHYTOLOGIST*, 150(2), 385-395.
- Lindig-Cisneros, R. & Zedler, J., 2001. Effect of light on seed germination in *Phalaris arundinacea* L. (reed canary grass). *PLANT ECOLOGY*, 155(1), 75-78.

- Lipson, D., Bowman, W. & Monson, R., 1996. Luxury uptake and storage of nitrogen in the rhizomatous alpine herb, *Bistorta bistortoides*. *ECOLOGY*, 77(4), 1277-1285.
- Long, S., Ainsworth, E., Leakey, A., et al., 2006. Food for thought: Lower-than-expected crop yield stimulation with rising CO₂ concentrations. *SCIENCE*, 312(5782), 1918-1921.
- Markesteyn, L. & Poorter, L., 2009. Seedling root morphology and biomass allocation of 62 tropical tree species in relation to drought- and shade-tolerance. *JOURNAL OF ECOLOGY*, 97(2), 311-325.
- Maurer, D. & Zedler, J., 2002. Differential invasion of a wetland grass explained by tests of nutrients and light availability on establishment and clonal growth. *OECOLOGIA*, 131(2), 279-288.
- McCarthy, M., Enquist, B. & Kerkhoff, A., 2007. Organ partitioning and distribution across the seed plants: Assessing the relative importance of phylogeny and function. *INTERNATIONAL JOURNAL OF PLANT SCIENCES*, 168(5), 751-761.
- Miller, R. & Zedler, J., 2003. Responses of native and invasive wetland plants to hydroperiod and water depth. *PLANT ECOLOGY*, 167(1), 57-69.
- Nagel, J. & Griffin, K., 2004. Can gas-exchange characteristics help explain the invasive success of *Lythrum salicaria*? *BIOLOGICAL INVASIONS*, 6(1), 101-111.
- Nagel, J. & Griffin, K., 2001. Construction cost and invasive potential: Comparing *Lythrum salicaria* (Lythraceae) with co-occurring native species along pond banks. *AMERICAN JOURNAL OF BOTANY*, 88(12), 2252-2258.
- Nagel, J., Wang, X., Lewis, J., et al., 2005. Atmospheric CO₂ enrichment alters energy assimilation, investment and allocation in *Xanthium strumarium*. *NEW PHYTOLOGIST*, 166(2), 513-523.
- Nowak, R.S., Ellsworth, D.S. & Smith, S.D., 2004. Functional responses of plants to elevated atmospheric CO₂: do photosynthetic and productivity data from FACE experiments support early predictions? *New Phytologist*, 162(2), 253-280.
- Pal, M., Karthikeyapandian, V., Jain, V., et al., 2004. Biomass production and nutritional levels of berseem (*Trifolium alexandrinum*) grown under elevated CO₂. *AGRICULTURE ECOSYSTEMS & ENVIRONMENT*, 101(1), 31-38.

- Pattison, R., Goldstein, G. & Ares, A., 1998. Growth, biomass allocation and photosynthesis of invasive and native Hawaiian rainforest species. *OECOLOGIA*, 117(4), 449-459.
- Pearcy, R., Bjorkman, O., Caldwell, M., et al., 1987. Carbon gain by plants in natural environments. *BIOSCIENCE*, 37(1), 21-29.
- Perez, P., Morcuende, R., del Molino., et al., 2005. Diurnal changes of Rubisco in response to elevated CO₂, temperature and nitrogen in wheat grown under temperature gradient tunnels. *ENVIRONMENTAL AND EXPERIMENTAL BOTANY*, 53(1), 13-27.
- Perry, L. & Galatowitsch, S., 2004. The influence of light availability on competition between *Phalaris arundinacea* and a native wetland sedge. *PLANT ECOLOGY*, 170(1), 73-81.
- Poorter, H., 1993. Interspecific variation in the growth response of plants to an elevated CO₂ concentration. *VEGETATION*, 104, 77-97.
- Poorter, H. & Nagel, O., 2000. The role of biomass allocation in the growth response of plants to different levels of light, CO₂, nutrients and water: a quantitative review. *AUSTRALIAN JOURNAL OF PLANT PHYSIOLOGY*, 27(6), 595-607.
- Poorter, H. & Navas, M., 2003. Plant growth and competition at elevated CO₂: on winners, losers and functional groups. *NEW PHYTOLOGIST*, 157(2), 175-198.
- Raper, C. & Peedin, G., 1978. Photosynthetic rate during steady-state growth as influenced by carbon-dioxide concentration. *BOTANICAL GAZETTE*, 139(2), 147-149.
- Rasse, D., Peresta, G. & Drake, B., 2005. Seventeen years of elevated CO₂ exposure in a Chesapeake Bay Wetland: sustained but contrasting responses of plant growth and CO₂ uptake. *GLOBAL CHANGE BIOLOGY*, 11(3), 369-377.
- Rawson, H., Gifford, R. & Condon, B., 1995. Temperature gradient chambers for research on global environment change: portable chambers for research on short stature vegetation. *PLANT CELL AND ENVIRONMENT*, 18(9), 1048-1054.
- Read, J., Morgan, J., Chatterton, N., et al., 1997. Gas exchange and carbohydrate and nitrogen concentrations in leaves of *Paspopyrum smithii* (C-3) and *Bonteloua gracilis* (C-4) at different carbon dioxide concentrations and temperatures. *ANNALS OF BOTANY*, 79(2), 197-206.

- Reekie, E. MacDougall, C., Wong, I., et al., 1998. Effect of sink size on growth response to elevated atmospheric CO₂ within the genus *Brassica*. *CANADIAN JOURNAL OF BOTANY-REVUE CANADIENNE DE BOTANIQUE*, 76(5), 829-835.
- Reich, P., Walters, M. & Ellsworth, D., 1997. From tropics to tundra: Global convergence in plant functioning. *PROCEEDINGS OF THE NATIONAL ACADEMY OF SCIENCES OF THE UNITED STATES OF*, 94(25), 13730-13734.
- Reich, P., Walters, M. & Ellsworth, D., 1992. Leaf life-span in relation to leaf, plant, and stand characteristics among diverse ecosystems. *ECOLOGICAL MONOGRAPHS*, 62(3), 365-392.
- Reichard, S. & Hamilton, C., 1997. Predicting invasions of woody plants introduced into North America. *CONSERVATION BIOLOGY*, 11(1), 193-203.
- Rout, M. & Chrzanowski, T., 2009. The invasive *Sorghum halepense* harbors endophytic N₂-fixing bacteria and alters soil biogeochemistry. *PLANT AND SOIL*, 315(1-2), 163-172.
- Saebø, A. & Mortensen, L., 1995. Growth and regrowth of *Phleum pratense*, *Lolium perenne*, *Trifolium repens*, and *Trifolium pratense* at normal and elevated CO₂ concentrations. *AGRICULTURE ECOSYSTEMS & ENVIRONMENT*, 55(1), 29-35.
- Samarakoon, A. & Gifford, R., 1996. Elevated CO₂ effects on water use and growth of maize in wet and drying soil (vol 23, pg 53, 1996). *AUSTRALIAN JOURNAL OF PLANT PHYSIOLOGY*, 23(3), 401-401.
- Schooler, S., McEvoy, P. & Coombs, E., 2006. Negative per capita effects of purple loosestrife and reed canary grass on plant diversity of wetland communities. *DIVERSITY AND DISTRIBUTIONS*, 12(4), 351-363.
- Seebacher, L., 2008. *Phalaris arundinacea* control and riparian restoration within agricultural watercourses in King county, Washington Doctoral Dissertation., University of Washington.
- Sharkey, T., Bernacchi, C., Farquhar, G., et al., 2007. Fitting photosynthetic carbon dioxide response curves for C-3 leaves. *PLANT CELL AND ENVIRONMENT*, 30(9), 1035-1040.

- Shaver, G., Street, L., Rastetter, E., et al., 2007. Functional convergence in regulation of net CO₂ flux in heterogeneous tundra landscapes in Alaska and Sweden. *JOURNAL OF ECOLOGY*, 95(4), 802-817.
- Smith, S., Huxman, T., Zitzer, S., et al., 2000. Elevated CO₂ increases productivity and invasive species success in an arid ecosystem. *NATURE*, 408(6808), 79-82.
- Smith, D., 1968. Classification of several native North American grasses as starch or fructosan accumulators in relation to taxonomy. *Journal of the British Grassland Society*, 23, 306-309.
- Soussana, J. & Luscher, A., 2007. Temperate grasslands and global atmospheric change: a review. *GRASS AND FORAGE SCIENCE*, 62(2), 127-134.
- Stinson, K., Tranz, J., Petzold, J., et al., 2006. Architectural and physiological mechanisms of reduced size inequality in CO₂-enriched stands of common ragweed (*Ambrosia artemisiifolia*). *GLOBAL CHANGE BIOLOGY*, 12(9), 1680-1689.
- Stock, W. & Evans, J., 2006. Effects of water availability, nitrogen supply and atmospheric CO₂ concentrations on plant nitrogen natural abundance values. *FUNCTIONAL PLANT BIOLOGY*, 33(3), 219-227.
- Suarez, N., 2003. Leaf longevity, construction, and maintenance costs of three mangrove species under field conditions. *PHOTOSYNTHETICA*, 41(3), 373-381.
- Taiz, L. & Zeiger, E., 1998. *Plant Physiology* 2nd ed., Sunderland, Massachusetts: Sinaur Associates, Inc.
- Tamura, Y. & Moriyama, M., 2001. Nonstructural carbohydrate reserves in roots and the ability of temperate perennial grasses to overwinter in early growth stages. *Plant PRODUCTION SCIENCE*, 4, 56-61.
- Tanner, C., Cordell, J., Rubey, J., et al., 2002. Restoration of freshwater intertidal habitat functions at Spencer Island, Everett, Washington. *RESTORATION ECOLOGY*, 10(3), 564-576.
- Taub, D. & Wang, X., 2008. Why are Nitrogen Concentrations in Plant Tissues Lower under Elevated CO₂? A Critical Examination of the Hypotheses. *JOURNAL OF INTEGRATIVE PLANT BIOLOGY*, 50(11), 1365-1374.
- Tissue, D. & Oechel, W., 1987. Response of *Eriophorum vaginatum* to elevated CO₂ and temperature in the Alaskan tussock tundra. *ECOLOGY*, 68(2), 401-410.

- Tubiello, F., Amthor, J., Boote, K., et al., 2007. Crop response to elevated CO₂ and world food supply - A comment on "Food for Thought..." by Long et al., *Science* 312 : 1918-1921, 2006. *EUROPEAN JOURNAL OF AGRONOMY*, 26(3), 215-223.
- Upreti, D., 1998. Carbon dioxide enrichment technology: Open top chambers a new tool for global climate research. *JOURNAL OF SCIENTIFIC & INDUSTRIAL RESEARCH*, 57(5), 266-270.
- Upreti, D. et al., 2002. Effect of elevated carbon dioxide concentration on the stomatal parameters of rice cultivars. *PHOTOSYNTHETICA*, 40(2), 315-319.
- USDA, NRCS, 2009. *The PLANTS Database*. Available at: <http://plants.usda.gov> [Accessed May 21, 2009].
- Vanden Heuvel, J. & Davenport, J., 2006. The impact of nitrogen application on nonstructural carbohydrate production in cranberry leaves. *HORTSCIENCE*, 41(4), 124.
- Vitousek, P., Aber, J., Howarth, R., et al., 1997. Human alteration of the global nitrogen cycle: Sources and consequences. *ECOLOGICAL APPLICATIONS*, 7(3), 737-750.
- Volder, A., Gifford, R. & Evans, J., 2007. Effects of elevated atmospheric CO₂, cutting frequency, and differential day/night atmospheric warming on root growth and turnover of Phalaris swards. *GLOBAL CHANGE BIOLOGY*, 13(5), 1040-1052.
- Wang, C. & Tillberg, J., 1996. Effects of nitrogen deficiency on accumulation of fructan and fructan metabolizing enzyme activities in sink and source leaves of barley (*hordeum vulgare*) . *Physiologia Plantarum*, 97, 339-345.
- Wang, C., Van den Ende, W. & Tillberg, J., 2000. Fructan accumulation induced by nitrogen efficiency in barley leaves correlates with the level of sucrose: fructan 6-fructosyltransferase mRNA. *Planta*, 211, 701-707.
- Weltzin, J., Belote, R. & Sanders, N., 2003. Biological invaders in a greenhouse world: will elevated CO₂ fuel plant invasions? *FRONTIERS IN ECOLOGY AND THE ENVIRONMENT*, 1(3), 146-153.
- Wolfe, D., Gifford, R., Hilbert, D., et al., 1998. Integration of photosynthetic acclimation to CO₂ at the whole-plant level. *GLOBAL CHANGE BIOLOGY*, 4(8), 879-893.

- Wright, I., Reich, R., Westoby, M., et al., 2004. The worldwide leaf economics spectrum. *NATURE*, 428(6985), 821-827.
- Wrobel, C., Coulman, B. & Smith, D., 2009. The potential use of reed canarygrass (*Phalaris arundinacea* L.) as a biofuel crop. *ACTA AGRICULTURAE SCANDINAVICA SECTION B-SOIL AND PLANT SCIENCE*, 59(1), 1-18.
- Zedler, J. & Kercher, S., 2004. Causes and consequences of invasive plants in wetlands: Opportunities, opportunists, and outcomes. *CRITICAL REVIEWS IN PLANT SCIENCES*, 23(5), 431-452.
- Zedler, J. & Kercher, S., 2005. Wetland resources: Status, trends, ecosystem services, and restorability. *ANNUAL REVIEW OF ENVIRONMENT AND RESOURCES*, 30, 39-74.
- Ziska, L., 2003. Evaluation of the growth response of six invasive species to past, present and future atmospheric carbon dioxide. *JOURNAL OF EXPERIMENTAL BOTANY*, 54(381), 395-404.
- Ziska, L., 2008. Three-year field evaluation of early and late 20th century spring wheat cultivars to projected increases in atmospheric carbon dioxide. *FIELD CROPS RESEARCH*, 108(1), 54-59.
- Ziska, L., George, K. & Frenz, D., 2007. Establishment and persistence of common ragweed (*Ambrosia artemisiifolia* L.) in disturbed soil as a function of an urban-rural macro-environment. *GLOBAL CHANGE BIOLOGY*, 13(1), 266-274.

APPENDIX A. LIST OF DATA TRANSFORMATIONS

Table A.1 Data were transformed as needed to meet assumptions of equal variance. Transformations were based on Box-Cox Power Transformations and confirmed by visual assessment of graphical representations of the data. The transformations are below.

	<i>Phalaris arundinacea</i>	<i>Glyceria striata</i>
Absolute Biomass		
Whole-plant biomass	Log(y)	Log(y)
Leaf biomass	Log(y)	1/sqrt(y)
Stem biomass	Log(y)	Log(y)
Rhizome biomass	Log(y)	sqrt(y)
Root biomass	Log(y)	Log(y)
Tiller number	1/sqrt(y)	1/sqrt(y)
Biomass Ratios		
Leaf mass ratio	Not transformed	Not transformed
Stem mass ratio	Not transformed	Not transformed
Rhizome mass ratio	Not transformed	Log(y)
Root mass ratio	Not transformed	Log(y)
Rhizome:root ratio	Log(y)	Log(y)
Belowground:aboveground	Log(y)	Log(y)
Misc. Physical Param.		
Specific leaf area	Not transformed	Not transformed
Leaf area	Log(y)	Not transformed
Water use	Log(y)	1/sqrt(y)
Fructan, Carbon, and Nitrogen		
% Carbon	Not transformed	Not transformed
% Nitrogen	Not transformed	Not transformed
Carbon:Nitrogen	1/sqrt(y)	1/(y)
% Fructan	Not transformed	Not assessed
Fructan:Carbon	Sqrt(y)	Not assessed
Gas Exchange		
Stomatal conductance (g _s)	Sqrt(y)	Not transformed
V _{cm_{ax}} of Rubisco	Not transformed	Sqrt(y)
Photosynthesis (A)	Log(y)	Sqrt(y)