

Bound Plackets

Plackets are used to finish garment openings and allow dressing ease. They are used at necklines with neckbands, sleeves with cuffs, and at waistlines with waistbands. Plackets may also be used as design elements at pant and skirt hems.

Continuous Lap Placket

The continuous lap placket can be used on sleeves, at the back of a neckline, or below a back button opening especially on children's wear. The placket binding may be cut on the straight grain or bias from the same fabric as the garment being made. It should be cut $1\frac{1}{4}$ inches wide and be one inch longer than twice the length of the placket opening. Press $\frac{1}{4}$ inch under along one long edge of the binding.

Prepare the placket opening by transferring the pattern marking to the garment. Following the marking; stitch with small machine stitches (15 stitches per inch) to reinforce the opening. Taking one or two stitches across the point of the marking will make cutting the opening easier. Cut the opening between the stitched lines all the way to the point being careful not to clip the reinforcement stitches. (Figure 1)

Spread the cut area open and place the right side of the placket binding to the wrong side of the garment. Pin the reinforcement stitching $\frac{1}{4}$ inch from the edge of the binding. Sew $\frac{1}{4}$ inch seam just outside of the reinforcement stitching. (Figure 2) Bring folded edge of binding to front covering the previous stitching and sew close to the fold. (Figure 3) Fold placket into place, lapping binding evenly by folding binding under on the overlap. (Figure 4)

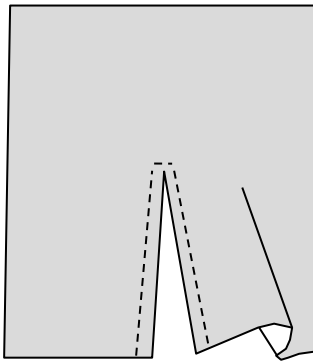

Figure 1

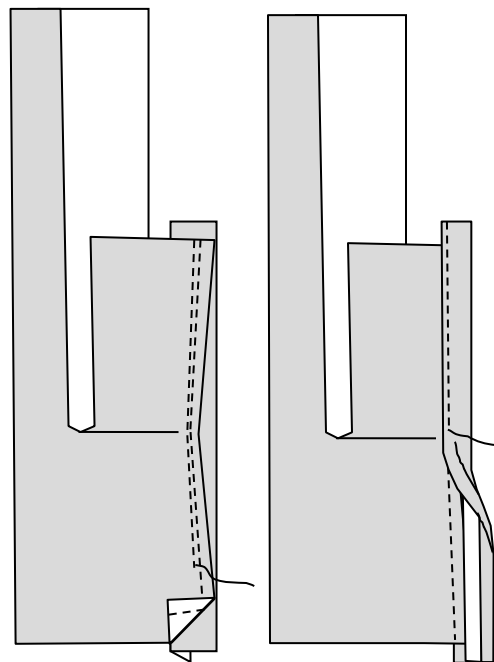

Figure 2

Figure 3

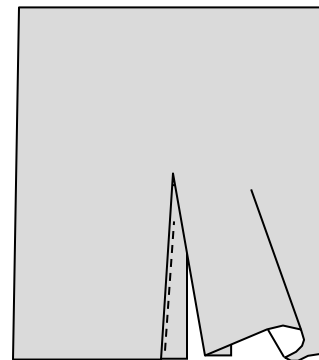

Figure 4

Tailored Shirt Placket

The tailored shirt placket can be used at the front neck opening or on the lower edge of the sleeve. It is a durable finish for both areas. Buttonholes can be sewn through the placket for added security. Follow the diagram for drawing the placket binding pattern. (Figure 5) Cut pattern from fabric on the straight grain. Remember to reverse the pattern when using as a sleeve placket. Press the outside edges of the placket to inside along the $\frac{1}{4}$ inch fold lines. Fold corners down and press forming the triangle shape. (Figure 6)

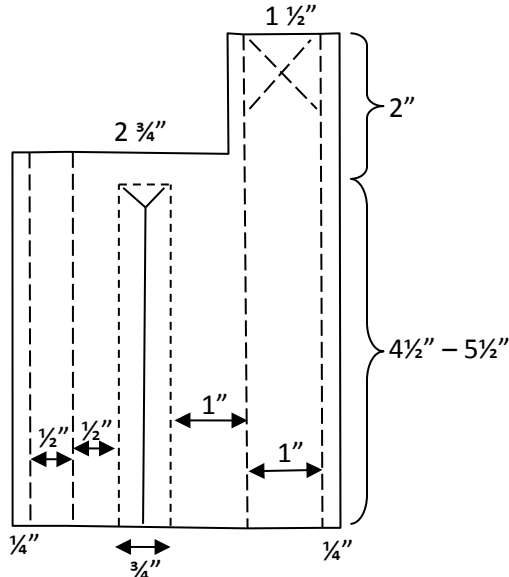

Figure 5

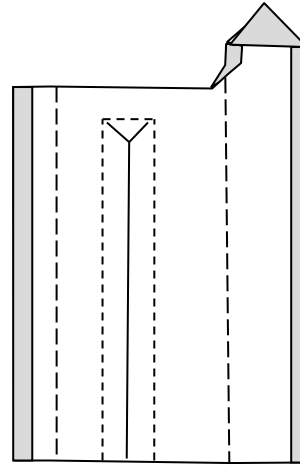

Figure 6

Pin the placket right side to the garment wrong side at the desired garment opening. Stitch along stitching lines. Cut opening; snipping to each corner. Be careful not to clip the stitching at the corners. (Figure 7) Fold placket towards the opening stitching lines and press. (Figure 8)

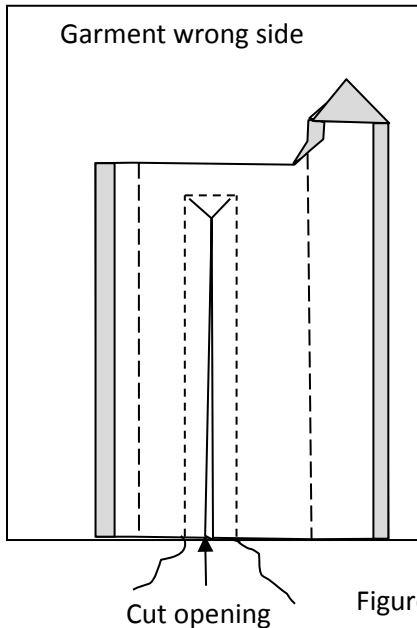

Figure 7

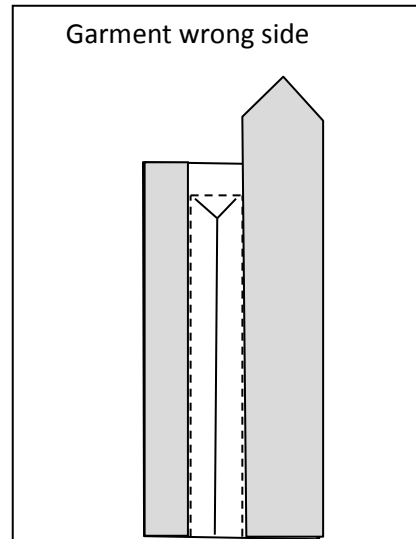

Figure 8

Turn placket to right side of garment. (Figure 9) Refold under placket along creased folds. Stitch close to fold covering the cut edge and previous stitching. (Figure 10) Refold upper placket and edge stitch close to fold through upper placket only. (Figure 11) Fold upper placket over under placket, covering the opening. Stitch through all fabric layers across the placket and around the remaining folded edges, enclosing the cut edges and previous stitching. (Figure 12)

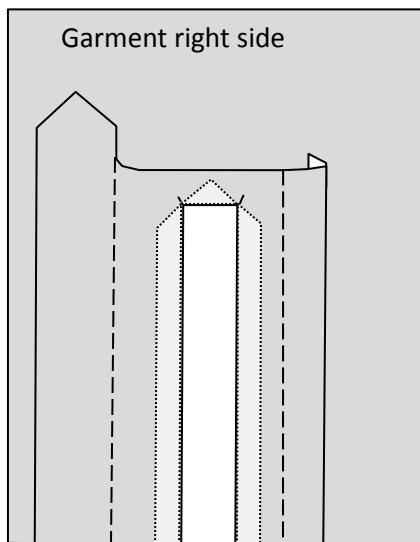

Figure 9

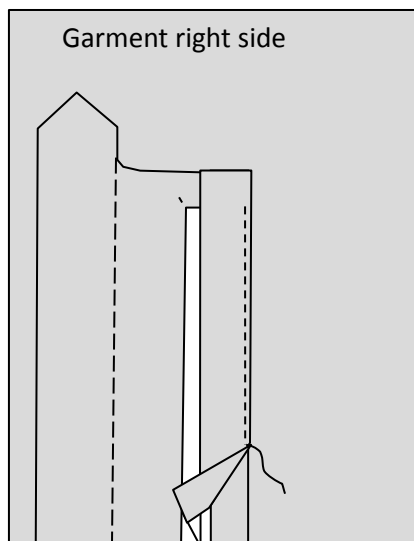

Figure 10

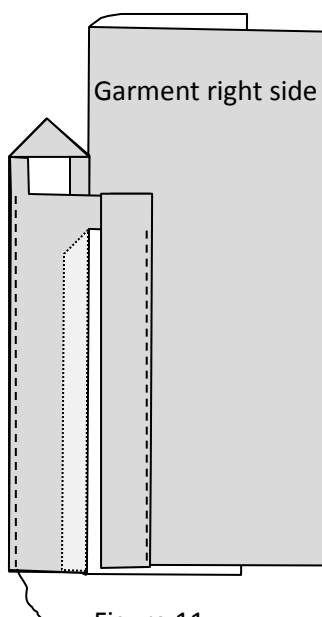

Figure 11

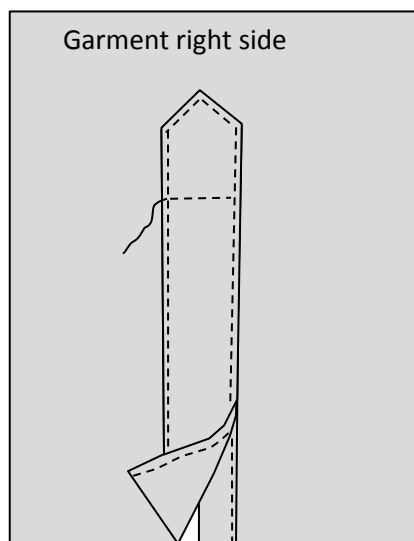

Figure 12

Rugby Placket

A rugby placket can be added to a shirt neckline. For girl's shirts, mark the placket opening $\frac{5}{8}$ inch to the left of the center to lap right over left. (Figure 13) For a boy's shirt, mark the placket opening to the right of the center to lap left over right.

Cut placket facing $4\frac{1}{4}$ inches wide by the length of the opening plus 2 inches. Interface the facing. Mark the cutting line $1\frac{1}{2}$ " from the long edge of the facing. (Figure 14) This line and the placket opening should be 5 – 6 inches long. Press under $\frac{1}{4}$ inch on each long side of facing. Place facing right side to shirt right side matching the marked lines. Use 15 stitches per inch; machine stitch $\frac{1}{8}$ inch away from the line tapering to the point. Pivot and take 1 – 2 stitches across the point, pivot again and continue stitching $\frac{1}{8}$ inch way from the line back to the top. (Figure 15) Carefully cut between stitching to point. (Figure 16)

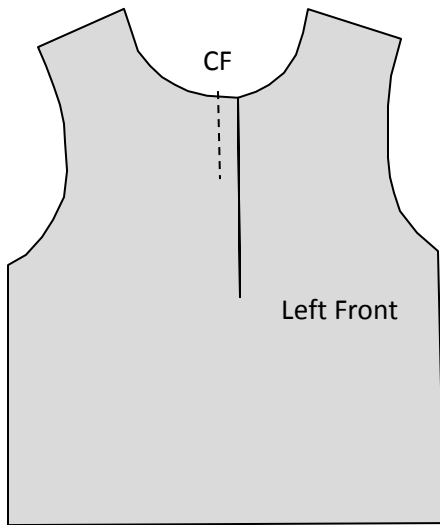

Figure 13

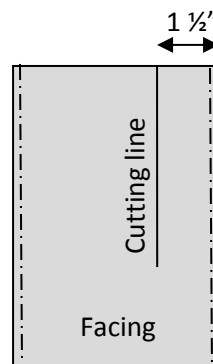

Figure 14

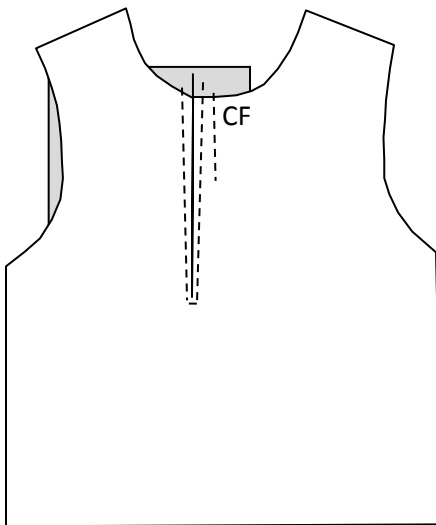

Figure 15

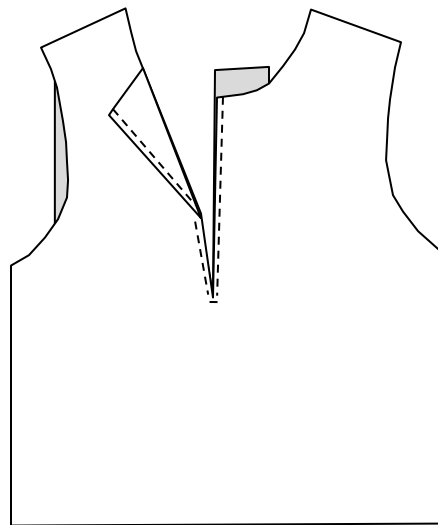

Figure 16

Sew front to back at shoulder seams and add collar or neckband if desired. *(Not illustrated)*

To finish neckline, fold facing back on itself 1¼ inches. (Figure 17) Trim facing even with top of neck edge. Apply bias or knit facing strip to neckline seam, covering the facing at each end. (Figure 18)

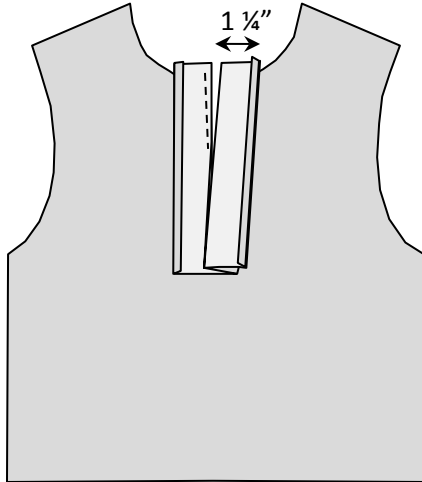

Figure 17

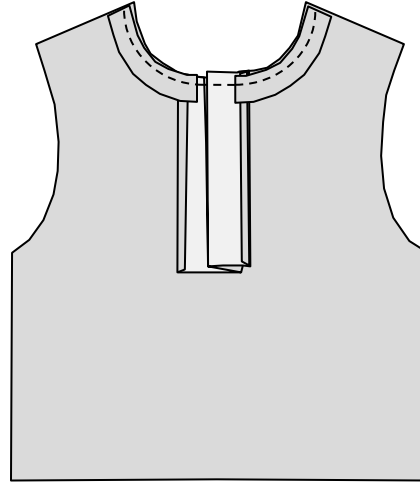

Figure 18

Turn placket facing and facing strip to inside of garment. Press placket flat. Trim and turn under or overcast lower edge of placket facing. Topstitch the length of the overlap catching in the folded edge of the packet facing underneath. Stitch in the ditch on the underlap side catching other folded edge of the packet facing underneath. (Figure 19) Topstitch neckline facing strip and lower end of opening forming a rectangle. (Figure 20)

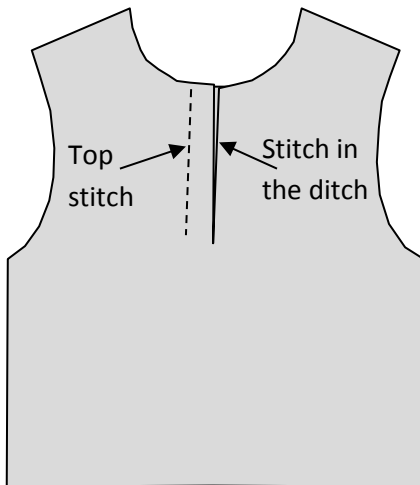

Figure 19

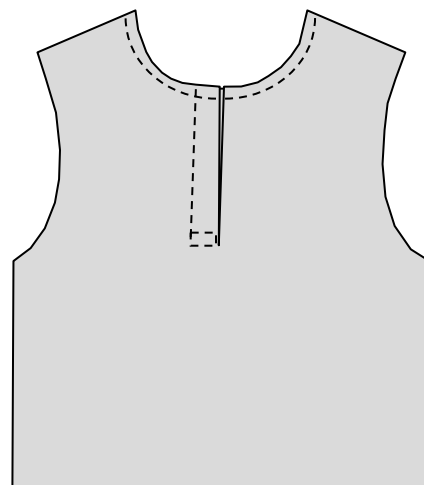

Figure 20

Henley Placket

The Henley placket is most often found at the neckline of a collarless shirt. Because buttons and buttonholes are added, the placket should be interfaced for added stability.

Cut the placket piece 5 times the width and 1 inch longer than the desired opening. (Figure 21)

Example: For a 1-inch wide placket, cut the placket piece 5½ inches wide.

Position center of placket piece to center front of garment, right sides together. Use 15 stitches per inch; machine stitch along placket stitching line. Cut along center line stopping short of the end and angle cut to each corner as illustrated. (Figure 22)

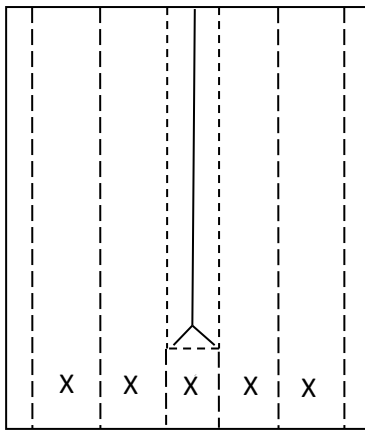

Figure 21

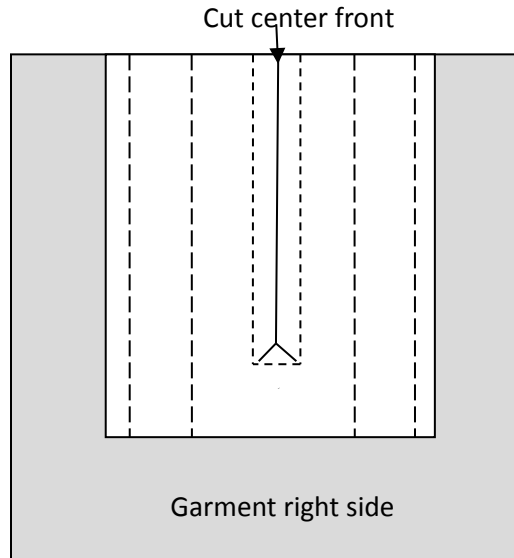

Figure 22

Press cut edges towards placket piece along stitching lines. Press under ¼ inch on each long side of placket piece. (Figure 23) Fold sides in to meet stitching lines. (Figure 24)

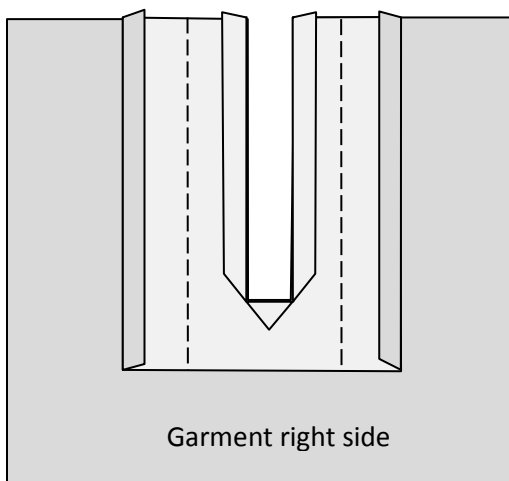

Figure 23

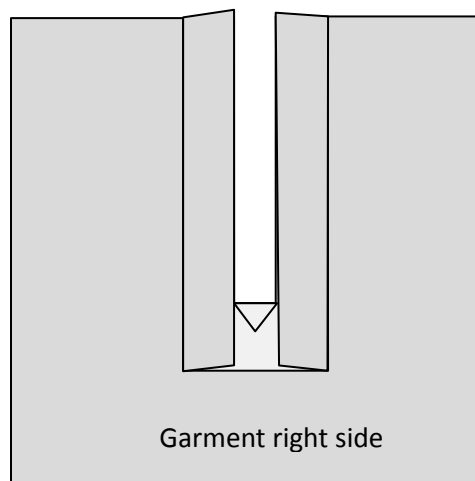

Figure 24

Sew front to back at shoulder seams. (Not illustrated)

Fold placket band back along crease line with right sides together. Sew collar band to neck edge overlapping placket band. (Figure 25) Overcast neckline seam and turn placket bands right side out. Fold garment away from placket and edge stitch close to both long edges stopping stitching at collar band. Repeat for other side of placket. Tuck the ends of the placket bands around to the underside of the garment. Lap left band over right for men (Figure 26) or right over left for women.

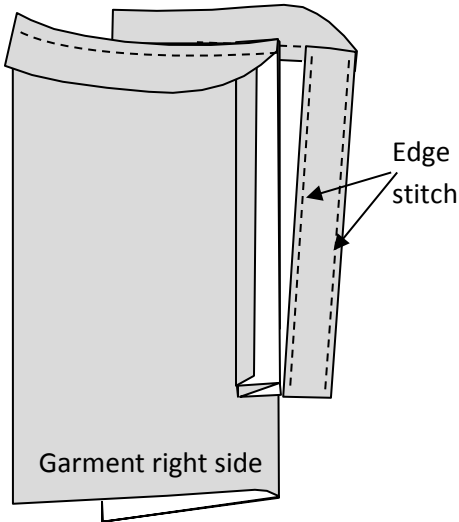

Figure 25

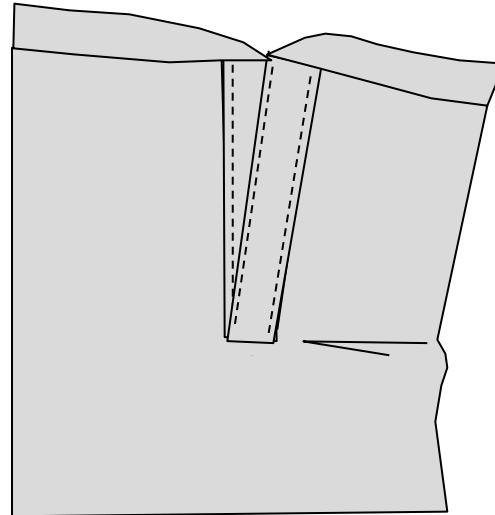

Figure 26

Fold garment away from placket end to reveal the small triangle. Stitch over previous stitching through all layers of the placket. (Figure 27) Add buttons and buttonholes. (Figure 28)

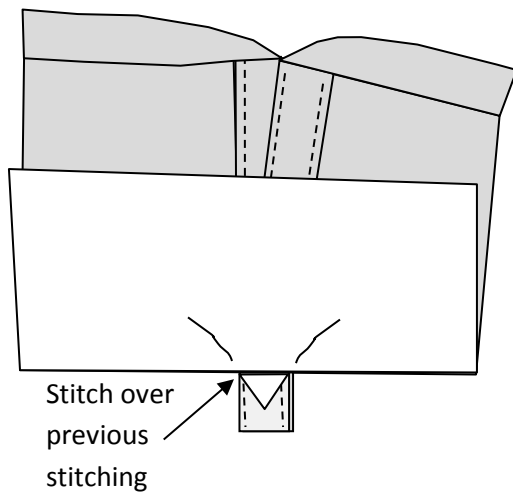

Figure 27

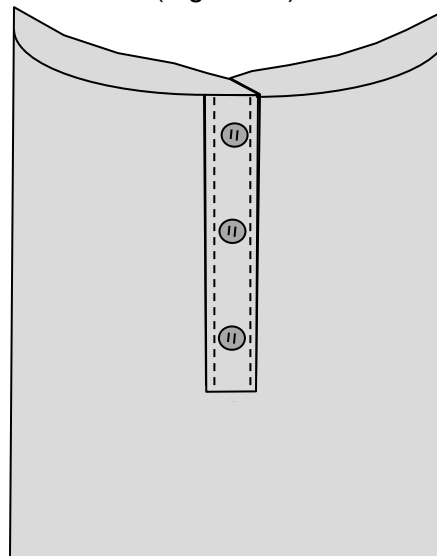

Figure 28

Marjorie M. Baker, M.S.
Extension Associate for Clothing and Textiles

January 2011

Copyright © 2015 for materials developed by University of Kentucky Cooperative Extension. This publication may be reproduced in portions or its entirety for educational or nonprofit purposes only. Permitted users shall give credit to the author(s) and include this copyright notice. Educational programs of Kentucky Cooperative Extension serve all people regardless of race, color, age, sex, religion, disability or national origin.