

SHORT AND LONG WAVE RADIATION: TFLEX FLEX
 GILL SONIC ANEMOMETER, FLEX
 GILL SONIC ANEMOMETER, TFLEX
 CO2 ANTENNA
 RAIN GAGE(2), FLEX & TFLEX
 SOLAR LIGHT, FL(5) Y 20s
 AT/RH, TFLEX MP-101 A
 AT/RH, FLEX MP101 A
 AT/RH2. FLEX HYGROCLIP
 RADAR REFLECTOR
 DRUCK BAROMETER, FLEX
 DRUCK BAROMETER, TFLEX

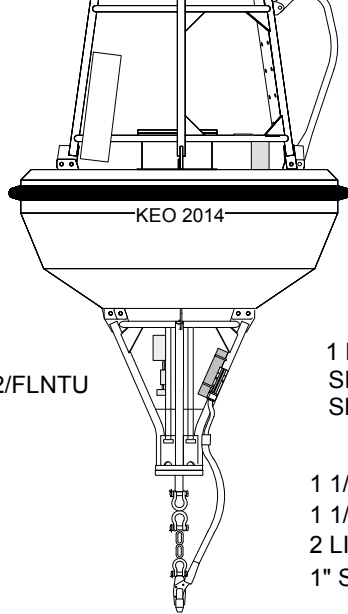

TFLEX TUBE
 TFLEX SYSTEM SOFT VER# 1.12

PMEL pCO2 ELECTRONICS-ÚT ÖŠ SPAN GAS-LUXFER
 Å
 ØSÖYÄYÜVÖT
 UUØVÅKÖÜÅFEGÁ

1 METER:
 UW SBE-16 CTD/GTD/02/FLNTU
 UW SBE-43
 SAMI pH SENSOR

1 METER:
 SBE 37SMP TC, FLEX
 SBE 37SMP TC TFLEX

1 1/4" SAS
 1 1/4" SAS
 2 LINKS 1" CHAIN
 1" SAS
 WRENCH TIGHTEN
 3 SHACKLES

2,322 METERS BOUYANT 7/8" POLYOLEFIN MOORING LINE

3/4" SAS WITH BUSHING
 .5 METER 1/2" CHAIN
 5/8" SAS
 5 TON SWIVEL; LOWER BODY OF SWIVEL ATTACHED TO BALLS
 5/8" SAS
 5/8" SAS
 4 METERS 1/2" CHAIN
 5/8" SAS
 4 METERS 1/2" CHAIN
 5/8" SAS
 4 METERS 1/2" CHAIN
 5/8" SAS
 4 METERS 1/2" CHAIN
 5/8" SAS
 4 METERS 1/2" CHAIN
 5/8" SAS
 .5 METERS 1/2" CHAIN
 3/4" SAS
 20 METERS 1 1/8" NYLON
 7/8" SAS
 .5 METER 1/2" CHAIN
 3/4" SAS
 5 TON SWIVEL
 3/4" SAS
 5/8" SAS
 TWIN 8242 ACOUSTIC RELEASES
 FACTORY CHAIN/RING KIT
 5/8" SAS
 .5 METER 1/2" CHAIN
 3/4" SAS
 50 METERS 1 1/8" NYLON
 3/4" SAS
 .5 M 3/4" CHAIN
 3/4" SAS
 5 TON SWIVEL
 3/4" SAS
 4 M 3/4" CHAIN

1.1 METERS 1/2" CHAIN

18 ea. 17" VITROVEX 6,700 METER GLASS BALL FLOATS. 1.5 METER SPACING BETWEEN 2 PACKS.

SBE-37SM TCP (DEPTH 56M-ABOVE BOTTOM)

WELD 3/4" SAS NUT

ALL SHACKLES WELDED CLOSED BELOW THIS LINE

3/8" wire rope shackled around anchor shafts

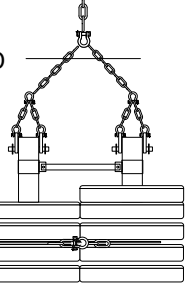

3/4" SAS
 1 M 1/2" CHAIN
 3/4" SAS
 ANCHOR BAR
 ANCHOR WEIGHT
 8,240#, AIR WT
 7,168#, WET WT.

Wrap 3/4" SAS pin/nut with Vulcanizing Tape, overwrap with black tape.

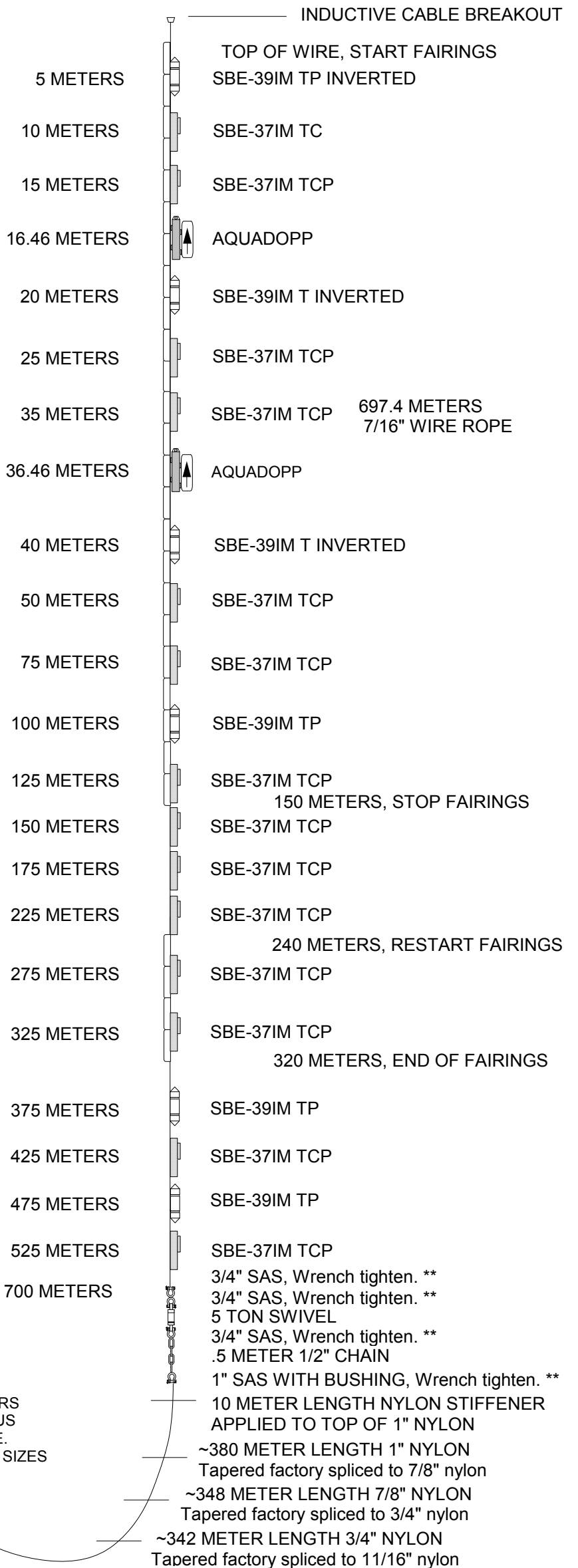

WRENCH TIGHTEN ALL SHACKLES	
DEPTH: 5760 METERS	
 NOAA-PMEL-KEO 7600 Sandpoint Way NE Seattle, Wa. 98115 (206) 526-6149	
MOORING:	KEO-012 AS DEPLOYED
SCOPE:	1.4:1
DRAWN BY:	MIKE CRAIG
DATE:	8 JANUARY 2015
DRAWN AS DEPLOYED:	