

GILL SONIC ANEMOMETER, FLEX  
 SHORT AND LONG WAVE RADIATION, FLEX  
 CO2 ANTENNA  
 ATRH, HYGROCLIP, FLEX  
 ATRH, ROTORNICS  
 MP-101A, FLEX  
 RADAR REFLECTOR  
 RECOVERY HANDLE

GILL SONIC ANEMOMETER, ATLAS  
 SHORT AND LONG WAVE RADIATION, ATLAS  
 FLEX RAIN GAGE  
 SOLAR LIGHT FI(5) Y 20s  
 VAISALA WXT520, FLEX(BP only)  
 AIR TEMPERATURE, RELATIVE HUMIDITY, ATLAS  
 DRUCK BAROMETER (FLEX)

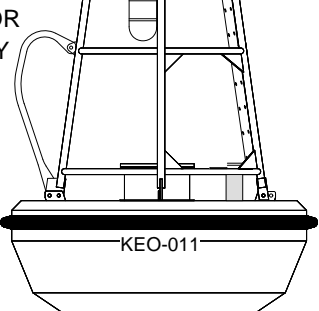

SABINE pCO2 & FLEX SYSTEMS  
 INTERNAL GPS & IRIDIUM ANTENNAS

SBE 16+V2 w/Optode, ECO FLNTUS, GTD CO2 (GTD-UW)  
 1 METER SSC, ATLAS  
 DOUBLE NUT AND TORQUE ALL NUTS TO 120 ft-#

1 METER SBE-37 SMP-TC, FLEX  
 SAMI pH  
 CABLE BRACKET  
 1 1/4" SAS  
 1 1/4" SAS  
 2 LINKS 1" CHAIN  
 1" SAS  
 INDUCTIVE CABLE BREAKOUT

5 METERS	INDUCTIVE CABLE BREAKOUT	TOP OF WIRE, START FAIRINGS
10 METERS		SBE-39IM TP INVERTED
15 METERS		SBE-37IM TC
16.46 METERS		AQUADOPP
20 METERS		SBE-39IM T INVERTED
25 METERS		SBE-37IM TC
35 METERS		SBE-37IM TC
36.46 METERS		AQUADOPP
40 METERS		SBE-39IM T
50 METERS		SBE-37IM TCP
75 METERS		SBE-37IM TCP
100 METERS		SBE-37IM TCP
125 METERS		SBE-37IM TCP
150 METERS		SBE-37IM TCP
175 METERS		SBE-37IM TCP
225 METERS		SBE-37IM TCP
240 METERS		RESTART FAIRINGS
275 METERS		SBE-37IM TCP
325 METERS		SBE-37IM TCP
350 METERS		END OF FAIRINGS
375 METERS		SBE-39IM TP
425 METERS		SBE-37IM TCP
475 METERS		SBE-39IM TP
525 METERS		SBE-37IM TCP
700 METERS		SBE-37SM TCP

2,322 METERS BOUYANT 7/8" POLYOLEFIN MOORING LINE

1.1 METERS 1/2" CHAIN  
 3/4" SAS WITH BUSHING  
 .5 METER 1/2" CHAIN  
 5/8" SAS  
 5 TON SWIVEL; LOWER BODY OF SWIVEL ATTACHED TO BALLS  
 5/8" SAS  
 5/8" SAS  
 4 METERS 1/2" CHAIN  
 5/8" SAS  
 4 METERS 1/2" CHAIN  
 5/8" SAS  
 4 METERS 1/2" CHAIN  
 5/8" SAS  
 4 METERS 1/2" CHAIN  
 5/8" SAS  
 4 METERS 1/2" CHAIN  
 5/8" SAS  
 1 METER 1/2" CHAIN (OMIT)  
 .5 METERS 1/2" CHAIN  
 3/4" SAS  
 20 METERS 1 1/8" NYLON  
 3/4" SAS (OMIT)  
 7/8" SAS  
 1 METER 1/2" CHAIN  
 3/4" SAS  
 5 TON SWIVEL  
 3/4" SAS  
 5/8" SAS  
 TWIN 8242 ACOUSTIC RELEASES  
 SBE-37SM TCP  
 FACTORY CHAIN/RING KIT  
 5/8" SAS  
 .5 METER 1/2" CHAIN  
 3/4" SAS  
 50 METERS 1 1/8" NYLON  
 3/4" SAS  
 .5 M 3/4" CHAIN  
 3/4" SAS  
 5 TON SWIVEL  
 3/4" SAS  
 4 M 3/4" CHAIN  
 WELD 3/4" SAS NUT

ALL SHACKLES WELDED CLOSED BELOW THIS LINE

3/8" wire rope shackled around anchor shafts

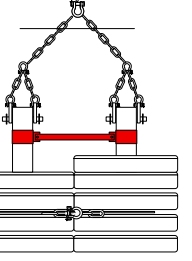

3/4" SAS  
 1 M 1/2" CHAIN  
 3/4" SAS  
 ANCHOR BAR EXTENDED FOR LARGE DIAMETER WHEELS  
 ANCHOR WEIGHT  
 8,240#, AIR WT  
 7,168#, WET WT.

\*\*Wrap 3/4" SAS pin/nut with Vulcanizing Tape, \*\* overwrap with black tape.

4,941 METERS CONTINUOUS NYLON LINE. TOTAL, ALL SIZES

FACTORY SPLICED NYLON TAPER 1,070 METERS TOTAL

WRENCH TIGHTEN ALL SHACKLES	
DEPTH: 5760 METERS	
<b>NOAA-PMEL-KEO</b> 7600 Sandpoint Way NE Seattle, Wa. 98115 (206) 526-6149	
MOORING:	KEO-011
SCOPE:	1.4:1
DRAWN BY:	Rick Miller
DATE:	1 MAY 2013
DRAWN AS DEPLOYED:	Rick Miller
	5 SEPT. 2013