

Solar Dynamics Observatory

The background of the entire page is a vibrant, fiery orange and red. It features a large, glowing sun-like sphere in the upper right, with bright, turbulent solar flares extending from its surface. In the lower left, there is a smaller, stylized sun with a cutaway section that reveals a bright yellow and white core, surrounded by a textured, orange-brown outer layer. The overall effect is one of intense heat and dynamic energy.

*“...to understand the nature and source
of the solar variations that affect
life and society.”*

Report of the Science Definition Team

Solar Dynamics Observatory Science Definition Team

David Hathaway
Chairman
Code SD50
NASA/MSFC
Huntsville, AL 35812

John W. Harvey
National Solar Observatory
P.O. Box 26732
Tucson, AZ 85726

K. D. Leka
Colorado Research Division
Northwest Research Assoc.
3380 Mitchell Lane
Boulder, CO 80301

Spiro Antiochos
Code 7675
Naval Research Laboratory
Washington, DC 20375

Donald M. Hassler
Southwest Research Institute
1050 Walnut St., Suite 426
Boulder, Colorado 80302

David Rust
Applied Physics Laboratory
Johns Hopkins University
Laurel, MD 20723

Thomas Bogdan
High Altitude Observatory
P. O. Box 3000
Boulder, CO 80307

J. Todd Hoeksema
Code S
NASA/Headquarters
Washington, DC 20546

Philip Scherrer
HEPL Annex B211
Stanford University
Stanford, CA 94305

Joseph Davila
Code 682
NASA/GSFC
Greenbelt, MD 20771

Jeffrey Kuhn
Institute for Astronomy
University of Hawaii
2680 Woodlawn Drive
Honolulu, HI 96822

Rainer Schwenn
Max-Planck-Institut für Aeronomie
Max Planck Str. 2
Katlenburg-Lindau
D37191 GERMANY

Kenneth Dere
Code 4163
Naval Research Laboratory
Washington, DC 20375

Barry LaBonte
Institute for Astronomy
University of Hawaii
2680 Woodlawn Drive
Honolulu, HI 96822

Leonard Strachan
Harvard-Smithsonian
Center for Astrophysics
60 Garden Street
Cambridge, MA 02138

Bernhard Fleck
ESA Space Science Dept.
c/o NASA/GSFC
Code 682.3
Greenbelt, MD 20771

Judith Lean
Code 7673L
Naval Research Laboratory
Washington, DC 20375

Alan Title
Lockheed Martin Corp.
3251 Hanover Street
Palo Alto, CA 94304

Richard Harrison
CCLRC
Chilton, Didcot
Oxfordshire OX11 0QX
UNITED KINGDOM

John Leibacher
National Solar Observatory
P.O. Box 26732
Tucson, AZ 85726

Roger Ulrich
Department of Astronomy
UCLA, 9831 MSB
Los Angeles, CA 90024

Barbara Thompson
Project Scientist
Code 682
NASA/GSFC
Greenbelt, MD 20771

Table of Contents

1	Executive Summary	1
2	Overview	3
3	Current Scientific Understanding and Outstanding Questions	8
3.1	Solar Influences on Global Change and Space Weather	8
3.1.1	Irradiance Variations	8
3.1.2	Energetic Particles from Flares and CMEs	13
3.1.3	Coronal Structure and Solar Wind Variations	17
3.2	Mechanisms of Solar Variability	20
3.2.1	The Solar Cycle	21
3.2.2	Active Region Evolution	24
3.2.3	Small-Scale Magnetic Structure	27
4	Required Observations	32
4.1	Helioseismic Images	32
4.2	Longitudinal Magnetograms	33
4.3	Atmospheric Images	34
4.4	EUV Spectral Irradiance	35
4.5	Photometric Images	35
4.6	Vector Magnetograms	36
4.7	UV/EUV Spectra	38
4.8	Coronagraphic Images	39
4.9	Total Irradiance	40
4.10	Coronal Spectroscopy	41
4.11	Heliometry	42
5	Potential Instruments and Allocation of Resources	42
6	Mission Concept	43
6.1	Orbit Selection	44
6.2	Attitude Control System	45
6.3	Data and Communication System	46
6.4	Spacecraft Power	47
6.5	Instrument Module	47
6.6	Ground System	47
6.7	Mission and Science Operations	48
7	Concurrent Observations	49
7.1	STEREO	49
7.2	Solar-B	49
7.3	Solar Probe	49
7.4	SORCE	51
7.5	GOES/NPOESS	52
7.6	SOLIS	53
7.7	ATST	53
7.8	Solar Sentinels	54
7.9	Solar Orbiter	54
7.10	FASR	55
8	Acknowledgements	54

1 Executive Summary

The Solar Dynamics Observatory (SDO) is a cornerstone mission within the Living With a Star (LWS) program. SDO's mission is to understand the nature and source of the solar variability that affects life and society. As such, its principal functions are two-fold. First, it must make accurate measurements of those solar parameters that are necessary to provide a deeper physical understanding of the mechanisms that underlie the Sun's variability on timescales ranging from seconds to centuries. Second, through remote sensing, it must monitor and record those aspects of the Sun's variable radiative, particulate, and magnetic plasma outputs that have the greatest impact on the terrestrial environment and the surrounding heliosphere.

Our Sun is an active star. This activity impacts planet Earth and human society in numerous ways. Terrestrial climate, ozone concentrations in the stratosphere, and atmospheric drag on satellites all respond to variations in the Sun's radiative output. Astronauts, airline passengers, and satellite electronics are all imperiled by the energetic particles produced in solar flares and coronal mass ejections (CMEs). Electrical power to our homes and businesses, communications, and navigation systems can all be interrupted by geomagnetic storms driven by blasts in the solar wind. SDO will study the mechanisms of solar variability – through a broad spectrum of temporal, spatial, and energetic scales – to provide the tools and scientific understanding that will enable us to improve the quality of forecasts of solar activity. SDO will also provide the measurements that are critical as input to studies of the geospace environment at their point of origin in the Sun-Earth system in order to quantify the Sun's influence on global change and improve our characterizations and forecasts of space weather.

In this report we discuss several key science questions that derive from our present incomplete knowledge of the physical underpinnings of the Sun's variability. They are selected for the promise they hold in catalyzing a significant

advance in modeling, quantifying, and perhaps eventually predicting solar variability over the relevant timescales. Variable solar outputs necessarily impact parallel efforts aimed at understanding, modeling, and predicting the behavior of the Sun-Earth system. Accordingly, we also speak to the scientific issues and problems that arise from inadequate knowledge of solar radiative, particulate, and magnetic plasma outputs.

Together, the solar and terrestrial science questions and ongoing research activities point to specific observables that must be supplied by SDO for the successful operation of the LWS science program. This document identifies a set of required observables that best addresses the dual objectives of SDO. In so doing, it provides the basic arguments and the supporting evidence that leads to the identification of the essential observations. The nature of the required measurements in turn drives the choice of a geosynchronous (GEO) orbit for the spacecraft. A potential suite of instruments is described which is in principle capable of acquiring the required observables, while at the same time satisfying the logistical constraints imposed on the SDO.

The overarching science questions to be addressed by the SDO are:

- What mechanisms drive the quasi-periodic 11-year cycle of solar activity?
- How is active region magnetic flux synthesized, concentrated, and dispersed across the solar surface?
- How does magnetic reconnection on small scales reorganize the large-scale field topology and current systems? How significant is it in heating the corona and accelerating the solar wind?
- Where do the observed variations in the Sun's total and spectral irradiance arise, and how do they relate to the magnetic activity cycles?
- What magnetic field configurations lead to the CMEs, filament eruptions, and flares that produce energetic particles and radiation?
- Can the structure and dynamics of the solar wind near Earth be determined from the

magnetic field configuration and atmospheric structure near the solar surface?

- When will activity occur, and is it possible to make accurate and reliable forecasts of space weather and climate?

The answers to these pressing science questions are to be found in direct observations of the relevant solar activity and the interpretation of these data. To this end, the complement of SDO instruments should supply the following basic data types (ordered from solar interior outward, not by priority).

- Full-disk dopplergrams of appropriate spatial and temporal resolution, duration and continuity to permit accurate helioseismological inferences of conditions in the solar interior.
- Full-disk magnetograms capable of characterizing the surface magnetic field and its evolution, and monitoring the emergence and processing of magnetic flux.
- Full-disk precise photometric images to explore the temporal and spatial variability of the solar irradiance and determine couplings with the magnetic structures.
- Full-disk filtergrams recorded simultaneously in a variety of visible and EUV bandpasses to assess the dynamics and energetics of the solar atmosphere on global and active region scales.
- Sun-as-a-star EUV spectral irradiance measurements to monitor and record temporal variations of radiative outputs crucial for gauging ionospheric, mesospheric and thermospheric responses to solar forcing.
- Restricted field of view UV/EUV slit spectra to make precise diagnoses of plasma dynamics and energetics.
- White-light polarization brightness images of the solar corona to record and monitor coronal evolution and re-structuring important for generating geoeffective interplanetary disturbances.

To provide a context and a guide for proposals submitted in response to the forthcoming AO associated with SDO, we have devised a potential suite of generic instruments. The instruments

listed below satisfy the data requirements stated above while remaining within the financial and logistical limitations placed upon the SDO mission.

- Helioseismic/Magnetic Imager
- Atmospheric Imaging Array
- EUV Spectral Irradiance Monitor
- Coronagraph
- Photometric Mapper
- UV/EUV Spectrometer
- Vector Magnetograph

The first three instruments are of highest priority. SDO must include instruments such as these to fulfill its mission. All three provide data with proven value that are not likely to be supplied through other programs. The final four instruments are of high priority. The data they obtain are needed for the SDO mission but they may be supplied in some other, albeit compromised, form by other programs, may be more speculative in nature, or may tax the SDO resources. A Total Solar Irradiance Monitor is also considered to be of highest priority, but two TSI Monitors are expected to fly on other platforms concurrently with SDO.

The remainder of this document amplifies on the considerations that went into this selection of questions, critical data, and instrument complement. It provides the traceability from the scientific questions to the instrument requirements and mission design.

2 Overview

The primary goal of SDO is to understand the nature and source of the solar variations that affect life and society. This broad goal leads to two objectives. One objective is to understand the mechanisms of solar variability as characterized by three processes that operate on three different timescales – the solar cycle (months to centuries), active region evolution (hours to months), and small-scale magnetic element interactions (seconds to hours). The second objective is to understand the solar influences on global change and space weather as characterized by three different sources – irradiance variations, energetic particles from flares and CMEs, and plasma disturbances from solar wind structures.

With the exception of the slow evolutionary changes in solar structure over the last 4.5 billion years, all solar variability is magnetic in origin. The solar cycle is a magnetic cycle in which the Sun's magnetic poles reverse with a periodicity of approximately 11 years and intense magnetic fields erupt through the surface in sunspots whose numbers wax and wane with the cycle. Solar flares and CMEs occur when magnetic fields are stressed beyond their limits. The very structure of the corona and the solar wind is determined by the structure of the magnetic field. The heating of the Sun's corona and the acceleration of the solar wind are thought to be due to interactions between small-scale magnetic elements. SDO will help us to understand the mechanisms of solar variability by observing how the magnetic field is generated and structured and how this stored magnetic energy is released into the heliosphere and geospace. Our current scientific understanding leads to a series of outstanding questions that must be addressed by SDO. These questions lead to

observations, potential instruments, and a mission design.

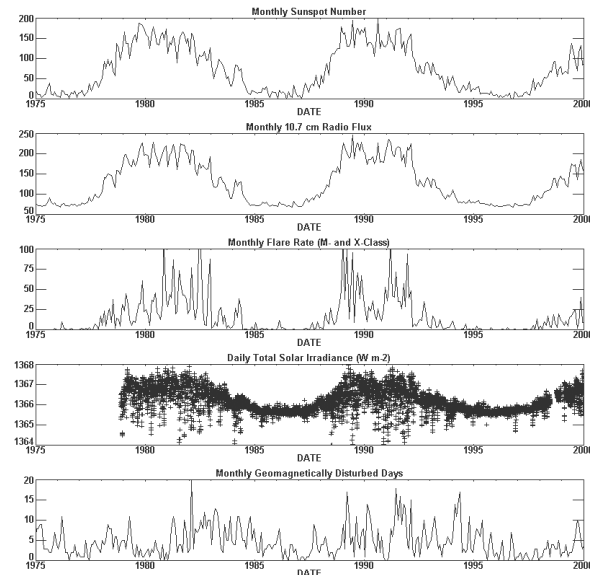

Figure 2.1. Recent solar cycle variability. Sunspot number and solar 10.7 cm radio flux (top two panels) are well-correlated indicators of solar variability. Solar flares (third panel) and total solar irradiance (fourth panel) generally follow the solar cycle. Geomagnetic variability (bottom panel) has a component in phase with the cycle but also shows considerable activity near solar minimum attributed to the effects of high-speed solar wind streams.

What mechanisms drive the quasi-periodic 11-year cycle of solar activity?

The solar cycle controls the long-term behavior of solar activity and the resultant modulation of the Sun's electromagnetic, particulate and magnetic plasma emissions that affect the Earth. Solar magnetic fields with their associated forces and electric currents are recognized as being responsible for the Sun's activity, but the underlying processes which create and then dissipate these fields in an 11-year cycle are poorly understood. Although helioseismology has revealed flows and thermal structures related to the magnetic variability, present theoretical models based on these observations can only broadly reproduce the observed magnetic evolution and are far from having pre-

dictive capability. Historical records suggest that the strength of the cyclic magnetic variations may have been different from what is observed today and that there may have been associated terrestrial climate changes. Furthermore, sun-like stars are observed to have a wider range of activity than is seen in the Sun, suggesting that current solar behavior could be misleadingly steady.

SDO will examine the processes that control the solar cycle. The SDO Magnetographs will measure the structure and evolution of the magnetic field itself. The Helioseismograph will measure the relevant fluid flows at levels within the Sun from the surface to the deep interior with unprecedented resolution and coverage. By extending the volume of the solar interior accessible to helioseismic probing and increasing its sensitivity in the crucial regions, SDO will provide data critical for understanding the 11-year activity cycle. The Photometric Mapper will measure temperature and radiance variations on the solar surface that are associated with the deep-seated drivers of the solar cycle while the EUV Spectral Irradiance Monitor measures the dramatic variations in the EUV.

How is active region magnetic flux synthesized, concentrated, and then dispersed across the solar surface?

The evolution of active regions controls the behavior of solar activity on timescales from hours to months. Sunspots cause decreases of a few tenths percent in total in solar irradiance. Energetic particles are released through magnetic reconnection associated with the evolution of active regions. Although simple isolated regions rarely produce flares or CMEs, complex sunspot groups with complicated and stressed magnetic field elements frequently do produce eruptive events. Bright active regions – evi-

dent as faculae in the photosphere, plage in the chromosphere and large loop structures in the corona – alter electromagnetic radiation at all wavelengths. The evolution of active regions depends upon the structure of the emerging magnetic flux, the local flow patterns, and the magnetic connections in the solar atmosphere.

SDO will have the capability to study active regions and their evolution by obtaining measurements unavailable from other missions or observatories. The Helioseismograph will measure the local flow patterns using observations with unique spatial resolution and coverage. It will have the ability to “see” active regions as they develop on the far side of the Sun and will resolve structures just below the surface. It may also be able to detect magnetic structures before they emerge at the surface, a capability shared with the Photometric Mapper. The Magnetographs and Atmospheric Imaging Array will provide critical information on the complexity of the magnetic structures in active regions. The resultant fluctuations recorded by the EUV Spectral Irradiance Monitor will capture the disk-integrated effect of the emergence, evolution and rotation of all active regions.

How does magnetic reconnection of solar magnetic fields on small spatial scales relate to coronal heating, solar wind acceleration and the transformation of the large-scale field topology?

The small-scale magnetic elements control solar activity on short timescales. As these elements erupt through the photosphere they interact with each other and with larger extant magnetic structures such as those associated with active regions. The magnetodynamic nature of small-scale magnetic flux may be the basis for short-term solar variability. They may provide the triggers for

eruptive events and their constant interactions may be a key source of coronal heating and solar wind acceleration. They may also contribute to irradiance variations in the form of enhanced network emission.

SDO will make critical observations of the small-scale magnetic elements, their interactions, and the resulting transformation of the large-scale field topology. The Magnetographs will have sufficient spatial and temporal resolution and coverage to follow the evolution of these elements. The Helioseismograph will determine the nature of the photospheric and sub-photospheric flows that control their motions. The Atmospheric Imaging Array will follow the magnetic connections within the atmosphere by simultaneously providing images of coronal loops at a series of different temperatures. The EUV Imaging Spectrometer will determine the physical conditions associated with these features including temperature and bulk velocity. The Coronagraph will provide information on the large-scale field topology and the associated solar wind.

Where do the observed variations in the Sun's total and spectral irradiance arise, and how do they relate to the magnetic activity cycles?

The Sun's electromagnetic radiation is the primary energy input to the Earth. This radiation varies at all wavelengths, and on all timescales observed thus far. Total solar irradiance varied by about 0.1% during recent 11-year sunspot cycles. While these variations are thought to be too small to have a dominant impact on climate, there is nevertheless considerable evidence in both contemporary and paleo-climate records of apparent solar-related variability. Variations in the solar UV are larger and have a direct and significant effect on stratospheric ozone concentrations. Still larger variations in the

Sun's EUV radiation cause dramatic fluctuations in the density of the Earth's outermost atmospheric layers and the electron density in the ionosphere, affecting the control and operation of earth-orbiting spacecraft, and communication and navigation systems. Magnetic features – sunspots, active regions, network – that alter the temperature and composition of the solar atmosphere are primary sources of solar irradiance variability.

SDO will make direct measurements of the solar irradiance, map the sources of the irradiance variations, and provide observations of the physical characteristics of these sources. The SDO EUV Spectral Irradiance Monitor will provide the first continuous, high time resolution measurements of the EUV irradiance variations that are critically important for changes in the Earth's upper atmosphere and ionosphere. The measurements will be made on a timescale of seconds while the SDO mission provides coverage over the solar cycle. The Photometric Mapper will provide unique imaging capability in bolometric intensity and in visible and IR bandpasses that allow for the positive identification of the solar sources of the total irradiance variations. The Atmospheric Imaging Array will provide coincident images of the full solar disk made in EUV radiation at selected emission temperatures so as to identify the sources of the observed EUV variations. SDO will also provide measurements to aid in our understanding of the sources of the irradiance variations. The EUV Imaging Spectrometer will examine the physical conditions of key features. Magnetograms will provide information on the magnetic nature of the features and their interactions while Helioseismic images provide information on related sub-surface structures and flows.

What magnetic field configurations lead to the CMEs, filament eruptions, and flares that produce energetic particles?

The Sun emits energetic particles during solar flares and CMEs. The energetic particle flux in a large proton flare can be lethal to an astronaut outside the protective envelope of Earth's magnetosphere. Significant particle fluxes penetrate to aircraft altitudes where they pose a health risk to passengers and crew. Showers of these energetic particles degrade and destroy electronic components on commercial, military, and research satellites. They also cause short-term depletions of the ozone layer, especially in polar regions. The solar eruptions that produce large fluxes of energetic particles are also magnetic in nature, frequently resulting from the reorganization of magnetic fields in the outer solar atmosphere.

SDO will provide continuous and improved observations of the solar conditions that lead to eruptive events such as flares and CMEs. Magnetographs will provide images of the underlying magnetic field. The Atmospheric Imaging Array will reveal the resulting structures in the chromosphere and corona at the spatial and temporal resolution of the TRACE imager but with the full-disk coverage of the SOHO/EIT instrument. The Coronagraph will detail the structure and evolution of the corona and CMEs while the EUV Imaging Spectrometer examines the physical conditions at key positions associated with the energetic particle events.

Can the structure and dynamics of the solar wind be determined from the magnetic field configuration and atmospheric structure near the solar surface?

Disturbances in the solar wind rack the Earth's magnetosphere and drive geomagnetic storms. These storms enhance and re-

organize populations of energetic particles in the Earth's magnetosphere, radiation belts, and ionosphere. Storm-induced electric currents can flow through power lines, overpower circuit breakers and transformers, and ultimately disrupt power distribution. Sudden changes in the electron density and structure of the ionosphere can hamper global positioning systems and radio communications. During maxima of the solar cycle CMEs are the primary contributors to these solar wind disturbances. Near minima the disturbances are dominated by variations in the structure of the solar wind itself. Solar wind structures also modulate the flux of galactic cosmic rays, allowing a larger flux of cosmic rays at the Earth during periods of lower solar activity. The resultant cosmogenic isotopes – ^{14}C and ^{10}Be – when stored in tree rings and ice cores produce unique archives of long-term solar variability that are crucial to untangling solar influences on Earth's past climate. There is even speculation that galactic cosmic rays may alter climate by creating cloud condensation nuclei.

SDO will observe the structure and dynamics of both the corona and the source region of the solar wind. The Coronagraph will observe both CMEs and solar wind structures. The Magnetographs and Atmospheric Imaging Array will reveal the related magnetic structures closer to the surface. The EUV Imaging Spectrometer will examine the physical conditions that accompany the acceleration of the solar wind, the heating of the corona, and the initiation of CMEs. Coronal spectroscopy would be an important tool for detailed measurements of velocity, composition, and temperature.

When will activity occur, and is it possible to make accurate and reliable forecasts of space weather and climate?

Within the LWS Program SDO must provide the observations that are crucial for understanding and predicting solar variability on all timescales. SDO must provide the data that serves as inputs to, or boundary conditions for, the other systems within the LWS program. The extent to which space weather and climate can be predicted will be recognized only after we gain a better understanding of the sources and nature of solar variability by addressing the preceding questions.

SDO Science. In the following section (Section 3) we outline our current understanding of solar variability itself – irradiance variations, energetic particle emission by flares and CMEs, and solar wind variations – along with the mechanisms that drive this variability – the solar cycle, active region evolution, and small-scale magnetic element interactions.

SDO Instruments. The outstanding scientific questions that arise can be addressed by a set of observations as described in Section 4. A potential set of instruments to acquire these observations on SDO includes:

- Helioseismic/Magnetic Imager
- Atmospheric Imaging Array
- EUV Spectral Irradiance Monitor
- Coronagraph
- Photometric Mapper
- UV/EUV Imaging Spectrometer
- Vector Magnetograph

A Total Solar Irradiance (TSI) Monitor should also be included if redundant observations are not available concurrently with SDO. The detailed instrument capabilities are traced back to the scientific questions in the following sections. However, a brief description of the instruments should provide some initial guidance.

The **Helioseismic/Magnetic Imager** would extend the capabilities of the SOHO/MDI instrument by going to higher spatial and temporal resolution with continuous full-disk coverage. The **Atmospheric Imaging Array** would be similar to the SOHO/EIT and TRACE instruments but with several independent telescopes providing simultaneous observations with the spatial resolution of TRACE, an order of magnitude increase in temporal resolution and the full-disk coverage of EIT. The **EUV Spectral Irradiance Monitor** would provide long-term, continuous measurements of the solar irradiance from 1 nm to 120 nm. The **Coronagraph** would be similar to the SOHO/LASCO instrument but with far better spatial and temporal resolution along with extended spatial coverage from 1.1 R_{Sun} to 15 R_{Sun} . The **Photometric Mapper** would be unique to SDO. It would provide photometric and bolometric images of the solar radiance. The **UV/EUV Imaging Spectrometer** would be a high resolution, high time cadence imaging spectrometer designed to complement the Atmospheric Imaging Array and Magnetographs. The **Vector Magnetograph** would provide both the strength and direction of the magnetic flux across the full solar disk at 5-minute intervals.

SDO Mission Concept. The high resolution, rapid cadence, and continuous coverage required for the observations lead to an SDO Mission design that places the satellite into a geosynchronous orbit. This allows for continuous contact at high data rate with a dedicated ground station. A geosynchronous orbit can also be used to minimize the data interruptions caused by the satellite passing through the Earth's and the Moon's shadows. The **SDO Mission Concept** (Section 6) calls for a launch in late 2006 or early 2007 on a Delta booster. The mission would be for a nominal 5 years with an additional

5-year extended mission. The SDO mission will help us make great strides toward understanding the solar variability that affects life and society. The instruments will provide the observations that lead to a more complete understanding of the solar dynamics that drive variability in the Earth's environment.

3 Current Scientific Understanding and Outstanding Questions

We have learned much about the Sun and solar variability in the last few years. The scientific discoveries from missions such as SOHO and TRACE make headlines in the popular press and are occasionally featured on the nightly news. The very nature of scientific inquiry, however, teaches us that the more we learn the more we find that we don't understand. We have learned much about the solar influences on global change and space weather, but we have also found that we do not fully understand all sources of the irradiance variations and we can't reliably predict energetic particle eruptions or solar wind variations. Likewise, we have learned much about the structure and dynamics of the solar interior and the evolution of active region magnetic fields, but we still don't understand the solar dynamo and can't reliably predict the size of the next solar cycle or the emergence of the next active region. The understanding of the mechanisms of solar variability that we have gained from previous missions, ground-based observations, and theoretical studies leads us to additional questions that require new observations. In the following subsections we describe our current scientific understanding and list some of the outstanding questions that must be addressed by SDO.

We have divided the science into two broad areas with three subdivisions each. The solar

influences on global change and space weather represent one broad area. There are three significant types of solar influences: photons (irradiance), energetic particles (associated with flares and CMEs), and plasma (coronal structure and solar wind variability). The mechanisms of solar variability represent the other broad area. While these mechanisms are all magnetic in nature, they can be neatly separated according to the timescales associated with each: long-term (the solar cycle), mid-term (active region evolution), and short-term (small-scale magnetic element interactions). SDO must address **all** these areas to advance our understanding of the nature and source of the solar variations that affect life and society.

3.1 Solar Influences on Global Change and Space Weather

Understanding the solar influences on global change and space weather is increasingly important as society becomes more reliant on technology. Global warming and ozone depletion can be influenced by solar irradiance variations. The health and safety of satellites and astronauts can be influenced by energetic particles from solar flares and CMEs. Electrical power distribution to our cities can be interrupted by geomagnetic storms induced by variations in the solar wind. While our understanding of these effects and their solar origins has improved greatly over the past decade, many outstanding questions remain.

3.1.1 Irradiance Variations

The radiation that the Sun provides to the Earth varies at all wavelengths and on all timescales. While the Sun's fundamental energy source is the nuclear conversion of hydrogen to helium in the core, the immediate radiative energy source for the Earth's surface and lower atmosphere is the solar pho-

tosphere. The chromosphere and corona produce the UV, EUV and X-ray radiations that are the primary source of energy for the Earth's upper atmosphere and ionosphere. With million-year photon diffusion times in the core, the emergent luminosity at its outer boundary should be effectively constant on any total solar irradiance measurement timescale. Given the observed variability, it follows that the mechanisms that deliver energy to the photosphere must be variable.

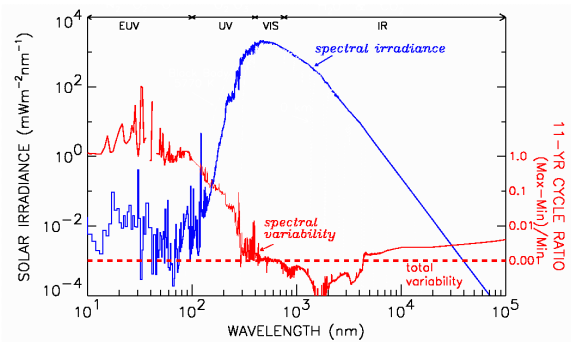

Figure 3.1. Solar spectral irradiance and its solar cycle variability as functions of wavelength. The solar cycle variability at wavelengths shorter than about 100 nm is typically greater than 100%.

The magnitude of the irradiance variability depends on the timescale and the wavelength of the radiation (Fig. 3.1). Most variable is EUV radiation at the shortest wavelengths. Emitted from outer layers of the solar atmosphere, this radiation exhibits rapid short-term order-of-magnitude fluctuations during solar flares and more gradual variations of a few orders of magnitude during the solar cycle. Least variable is the near infrared spectrum, emitted from the deepest layers of the photosphere, where flare-related variability is negligible and solar cycle changes are thought to be a few tenths of a percent, at most.

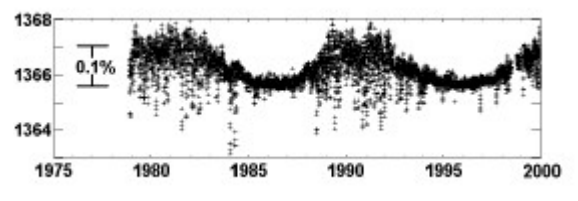

Figure 3.2. Total solar irradiance (W/m^2) as a function of time. Total solar irradiance varies by about 0.1% over a solar cycle and by several times that on shorter (solar rotation) timescales.

The spectrally integrated ‘total’ irradiance, of relevance to climate on Earth, varies by a few parts per million in association with p-mode oscillations, a few tenths percent during solar rotation, about 0.1% in recent solar cycles (Fig. 3.2), and possibly by a few tenths percent on longer timescales. The UV radiation from 160 to 300 nm that produces stratospheric ozone and modulates the middle atmosphere, varies by 1 to 20% during a solar rotation, about twice that during the solar cycle, and possibly more on longer timescales. Although the radiative output at ultraviolet wavelengths less than 400 nm constitutes only 8% of the total radiative output, the stronger variability at these shorter wavelengths makes a significant contribution (30%) to the total solar irradiance variations. The EUV radiation from 1 to 120 nm that produces the ionosphere and is the primary heat source for the thermosphere varies by 50% to factors of two or more during solar rotations and the solar cycle. Significant variations are expected during solar flares, but are presently unknown.

3.1.1.1 Irradiance Variations – Current Understanding

Magnetized features in the solar atmosphere are associated with solar irradiance variations across the entire electromagnetic spectrum. Magnetic fields in sunspots redirect the upward flow of energy from the convec-

tion zone and affect the emergent radiation locally in the photosphere. In bright magnetic regions, specifically active region plage, faculae and dispersed network, irradiance is locally enhanced. The interplay of locally “dark and bright” features causes variations in photospheric radiation (wavelengths > 200 nm) on timescales ranging from days to a solar cycle. Bright, magnetized features largely control the variability of chromospheric emission that includes some of the strongest EUV emission lines. In the outer solar atmosphere, magnetic fields in active regions expand to form coronal loop structures that at times cover a significant fraction of the global solar atmosphere. Density and temperature enhancements alter the emission in coronal magnetic loops and their presence causes significant increases in X-ray and extreme ultraviolet lines, especially during flares.

Fluctuations in total (spectrally integrated) irradiance are traceable to both sunspot and facular sources on short (solar rotation) timescales. The movement across the visible solar disk of a large sunspot group can cause the total irradiance to decrease by a few tenths of a percent. These short-term variations are superimposed on an overall total solar irradiance increase from sunspot minimum to maximum. Empirical models of sunspot darkening and facular brightening account for recent solar irradiance cycles, but the models require a factor of two more facular brightening than sunspot darkening during maximum. It is not clear that all the variation can be found in the faculae. Models for the flow of heat through the convection zone suggest that heat flow blockage by sunspots should restructure the convection zone and produce bright rings around active regions. Recent observations of bright rings around active regions and changes in the solar radius add to the controversy.

Ground-based measurements of the solar radius exist over the last 300 years, but these results are controversial and inconsistent. Historical measurements show that the Sun's radius may even have been larger during the Maunder Minimum - during extremely cold periods in Europe and the Atlantic regions. The French CERGA radius measurements detected a larger solar radius during solar minimum. Others have found the opposite positive correlation between apparent radius changes and the solar activity cycle. There are also hints of periodic solar radius variations over timescales of 1,000 days to 80 years, but taken as a whole these measurements generally are neither consistent nor conclusive. It is apparent that the results to date have been severely limited by the atmosphere.

Because the nuclear energy generation rate is effectively constant on solar cycle timescales the Sun must be storing a fraction of this energy flux in thermal, gravitational, or magnetic forms in order for its net luminosity to vary. Each of these mechanisms leads to distinct perturbations in the equilibrium stellar structure and potentially detectable changes in the solar diameter. It follows that a sensitive determination of the solar radius fluctuations can help reveal the cause of the solar cycle changes.

Quantitative understanding of the magnetic sources of EUV irradiance variations is far less developed. Until recently, the only models of EUV irradiance variability were simply parameterizations of the 10.7 cm radio flux. In reality the database of reliable EUV irradiance observations is simply too limited to realistically constrain even the most simple of empirical models. This has led to a new approach of using differential emission measures (combined with atomic parameters of the emitting species) of specific magnetic features (active regions, co-

ronal holes) and the quiet background Sun, to construct full-disk EUV irradiance. Solar images (e.g., Ca K, SOHO/EIT, Yohkoh/SXT) provide estimates of the fractional volume covered by the respective features at any time during the solar cycle. This approach depends on having reliable emission measure distributions. Unfortunately, we have only a small number of suitable, calibrated, high spectral and spatial resolution observations covering the needed wide range of emission temperatures. Nevertheless, the new approach to quantifying magnetic sources of EUV irradiance variability from a more physical understanding of the temperature, density and atomic parameters is promising. The major challenge here is to obtain better data in the EUV lines of coronal and transition region origin. Many of these lines arise in structures whose areas are poorly estimated by traditional chromospheric indices such as Ca K and Mg II.

3.1.1.2 Irradiance Variations – Outstanding Questions

Where do the observed variations in the Sun’s total and spectral irradiance arise, and how do they relate to the magnetic activity cycles? This is the overarching question for the solar irradiance variations. It leads to a series of more focused questions in specific areas.

What are the sources of the total irradiance variations? The projected areas of sunspots and faculae are well correlated with the total solar irradiance variations. However, alternative sources such as luminosity changes due to radius variations associated with sunspots and faculae can also give this correlation. Present photometry of spots and faculae is not accurate enough to demonstrate that the irradiance effects are equal to – rather than merely proportional to – the

total irradiance variations attributed to them. An accurate (~10%) equality would be an important test of the models. Equality of the year-to-year photometric and radiometric contributions probably offers the cleanest discriminator between the enhanced network, and other explanations of the 11-year component of irradiance variation. Merely showing proportionality leaves open the possibility that more global changes also proportional to activity level might be playing a significant role.

[Text highlighted in gray provides the traceability between the scientific goals, the measurement characteristics, and the requirements on potential instruments for SDO.]

The **total solar irradiance** must continue to be monitored to address these questions. Efforts toward identifying the sources of these variations are of little use without knowledge of the variations themselves.

Photometric images, photometrically accurate narrowband images and broadband bolometric images, are needed to determine the actual sources of the irradiance variations. These images must have the spatial resolution to resolve sunspots and faculae and the accuracy and precision to determine their contribution to the total irradiance.

Magnetograms with comparable spatial resolution are also needed in order to discriminate between the magnetic and the non-magnetic irradiance sources.

Helioseismic images will aid in measuring variations in the size of the Sun that should be related to luminosity variations.

Heliometry – precise measurements of the size and shape of the Sun – will also aid in measuring variations in the size of the Sun

that should be related to luminosity variations.

How does the EUV spectral irradiance change on timescales of seconds to decades? There is a severe lack of knowledge of solar spectral irradiance variability at wavelengths shorter than 120 nm, where the database is characterized by intermittent observations made with poorly calibrated instruments. Solar cycle EUV irradiance variability amplitudes are uncertain by 50% or more, and variations associated with flares are essentially unknown. Only for the total irradiance and for the spectral irradiance from 120 to 400 nm do continuous, well-calibrated databases exist. NASA's Office of Earth Science (OES) has made these latter observations during the past decade at longer wavelengths for understanding natural variations in climate and ozone.

The **EUV spectral irradiance** shortward of 120 nm must be monitored. The observations should cover the neglected wavelength range from 1 nm to 120 nm with enough spectral resolution to be useful to solar, upper atmospheric and ionospheric studies. The temporal resolution should be short enough to follow flares, and the temporal coverage should extend through a solar cycle. These measurements should have sufficient short-term precision and long-term stability to monitor the EUV variations on timescales of flares to the solar cycle.

What are the sources of the spectral irradiance variations? Although magnetic regions are understood to be the primary cause of EUV and X-ray irradiance variations, the details of this association have yet to be determined. This is because of the complete absence of simultaneous well-calibrated full-disk images (that resolve the spatial features with adequate spectral resolution) and independent, spectrally-compatible, EUV irradi-

ance observations (to specify the actual variations and to verify the understanding developed from analysis of the images).

Atmospheric images like those obtained with SOHO/EIT and Yohkoh/SXT will aid in the identification and quantification of the spectral irradiance variations. Full-disk, narrowband EUV images at a series of EUV wavelengths should be taken simultaneously with the EUV spectral irradiance measurements. These images should have the spatial resolution to identify the nature of the features and the temporal resolution to follow the rapid variations in flares. The measurements must be made in a sound radiometric way that eliminates spurious instrumental or spacecraft effects. The spectral bands should be chosen such that emission measures spanning a range of temperatures from 10^4K to a few 10^6K can be constructed for individual or classes of magnetic elements.

UV/EUV spectra are needed to provide detailed information about the density and temperature of the plasma in individual magnetic regions on the Sun's disk. It is evident that a major contributor to irradiance changes are the variations in UV/EUV emission lines associated with regions of strong magnetic fields in the photosphere. Without sufficient spectral and spatial resolution it is not possible to understand the physical mechanisms responsible for the variations. High spectral resolution would provide significantly more reliable emission measure determinations, and the coordination with the full-disk images would provide global context for these spatially resolved observations.

Were solar irradiance variations larger in the historical past? Present specifications of solar total and spectral irradiance variability for terrestrial research are based largely on multi-component empirical mod-

els. Although these models can be quite complex, they represent a very simplified view of the structure of the solar atmosphere.

The ability to understand solar variations outside of the current era requires the development of physical models based on observations of the solar sources of the total and spectral irradiance variations at the necessary spectral and spatial resolution.

3.1.2 Flares and CMEs as the Source of Energetic Particles

Flares and CMEs are the primary sources of energetic particles from the Sun. Solar flares and coronal mass ejections are the largest explosions in the solar system, and are the root cause of much of the Earth's geomagnetic and ionospheric disturbances. The energetic particles produced in these explosions can be harmful to humans and electronic instruments in space. Figure 3.3 shows LASCO images of the solar corona before and after the flare of July 14, 2000. The energetic particles produced in this event showered the LASCO detector and made observations impossible for some time. The fundamental physics of these events remains elusive and predictions must become more reliable. These extremely complex phenomena require the explosive conversion of magnetic energy into accelerated particles, bulk mass motions, light, and heat. SDO must examine the evolving magnetic configurations associated with these events and identify their precursors.

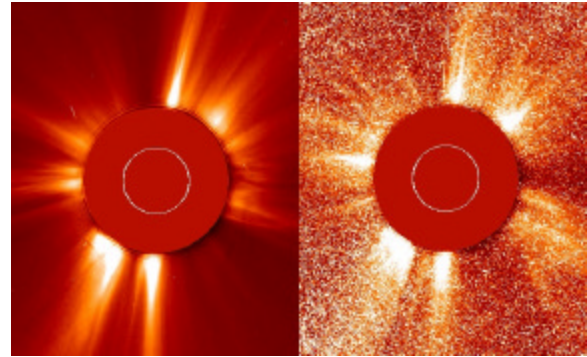

Figure 3.3. LASCO images of the solar corona before (left) and just after (right) the large flare of July 14, 2000 (the Bastille Day event). Energetic particles from the flare eventually overwhelmed the detector and made observations impossible for some time.

3.1.2.1 Flares and CMEs – Current Understanding

Solar flares have long been recognized as a key component of solar variability on short timescales. The advent of space-based observations has also added CMEs and shocks in the solar wind as significant components. Much has been learned about these phenomena and about how they accelerate particles to cosmic ray energies. Our understanding and predictive abilities have improved but not to the point where we can reliably predict the occurrence and geoeffectiveness of these events.

Solar flares can be detected at virtually all wavelengths. The NOAA GOES satellites include solar X-ray monitors that are used to detect and classify solar flares. The occurrence of flares is well correlated with the magnetic complexity of active regions. Delta spots, sunspots with opposite magnetic polarities included within a common penumbra, often produce flares. Detailed measurements of the magnetic field also reveal stressed magnetic field configurations in flaring active regions. Figure 3.4 shows a flaring active region along with the observed magnetic field and the stress-free field de-

rived from the observed line-of-sight field component. The magnetic field vectors are twisted or sheared in the region where this flare occurred. Other indicators of stressed field configurations include sigmoid, or S-shaped, coronal loops observed in images obtained in the UV/EUV. While these magnetic structures indicate the likelihood of a flare, they are not highly reliable and cannot indicate when a flare will occur or how strong it will be. Detailed determinations of the magnetic configurations in many flaring and non-flaring active regions are needed for systematic studies of these and other flare indicators.

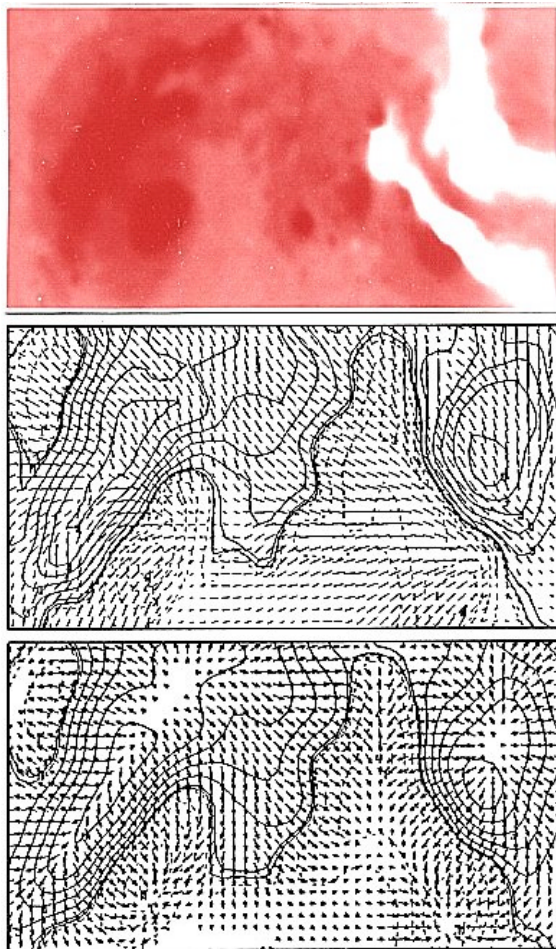

Figure 3.4. Stressed magnetic field configuration in a flaring active region (off-band $H\alpha$ - top panel). The observed magnetic field vectors (center panel) are twisted relative to the stress-free field vectors (bottom panel) in the region of the flare.

Traditionally CMEs have been observed with white light coronagraphs using polarizers and broadband filters. With the launch of SOHO, considerable progress toward a detailed description of CMEs is being made through a combination of observations with the EIT, LASCO and UVCS instruments. SOHO observations with the LASCO coronagraphs show that CMEs have a wide range of speeds from 100 km/s to greater than 1000 km/s. EIT observations show that a large CME can empty a substantial fraction of the corona. We know typical masses (10^{16} g) and total energies (10^{32} ergs) of CMEs, but not what causes the variations of these parameters from one CME to another. We need to know how the magnetic field energizes and accelerates CME material.

There is evidence that initially slower-speed CMEs that tend to have higher accelerations are related to prominence eruptions while the faster CMEs are associated with flare events but the correlation is not exact. SMM observations show that the range of CME speeds does not appear to be related to the amount of thermal input into the CME, so the variation must be related to the nonthermal energy from the magnetic field. UVCS observations indicate ionization states formed at temperatures over a broad range (from 10^4 to 10^7 K) and heat input comparable to the kinetic energy in the ejected material.

By their explosive nature, CMEs also reflect short-term changes in the configuration of the coronal magnetic field. On short timescales, magnetic reconnection of field lines is often seen just before and sometimes after a CME has erupted, but whether reconnection is a cause or an effect of the CME is still debated. There has been some success in using the presence of sigmoid magnetic fields in the low corona as a precursor for CME eruptions but it is not yet possible to

predict which sigmoid structures will erupt or when.

The geoeffectiveness of CMEs that strike the Earth is known to depend, in part, on the shock strength and on the direction of the magnetic field. Those CMEs that have southward directed interplanetary magnetic fields are known to produce the largest geomagnetic storms. Studies of the relationship between the direction of the magnetic field in CMEs and their geoeffectiveness conclude that accurate storm forecasting requires a means of predicting the magnetic field configuration in CMEs.

The process of magnetic reconnection is thought to be the principle mechanism by which magnetic energy is converted into thermal energy in flares and CMEs. A primary result of magnetic reconnection is the creation of new field line connectivities. On large spatial scales, the new plasma loops are often seen to connect pre-existing photospheric flux elements with newly emerged photospheric flux elements. The rate at which these new loops appear is on the order of 0.1% to 10% of the Alfvén time, indicating that this occurs in the regime of fast reconnection. The high electrical conductivity of the coronal plasma implies that small spatial scales are often needed in order for magnetic reconnection to occur at a reasonable rate. These spatial scales are below the resolution limit of current instrumentation.

Besides providing clues about the storage and release of magnetic energy, CMEs provide a major avenue (in addition to the fast and slow speed wind) for coupling the Sun's atmosphere to the more extended heliosphere. CMEs may be the fundamental means by which the Sun sheds both magnetic flux and helicity (Fig. 3.5) over the 11-year solar cycle. The rate of free energy built up over the solar cycle (in the form of

increasing helicity) may be about the same as the amount of free energy removed convectively by CMEs during a solar cycle. While there is good evidence for the expected flux and helicity transport in the past three decades of solar wind data, quantitative inferences about magnetic helicity from solar observations have been difficult to obtain.

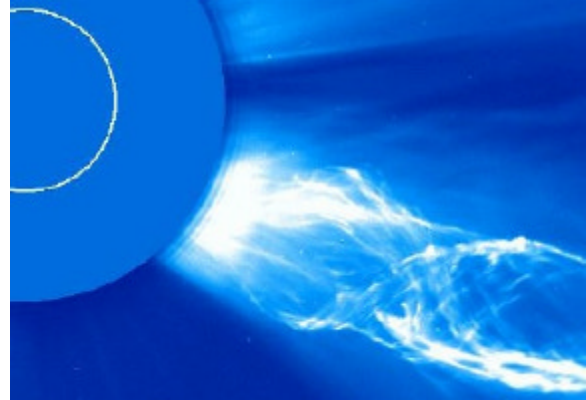

Figure 3.5. Helical structure in a CME observed with LASCO on June 2, 1998.

3.1.2.2 Flares and CMEs – Outstanding Questions

What magnetic field configurations lead to the CMEs, filament eruptions, and flares that produce energetic particles? Our current understanding of flares and CMEs suggests that the magnetic field configuration and its evolution determine the development of these explosive events. The photospheric magnetic fields often indicate the existence of stressed magnetic field configurations. However, the lack of significant changes in the photospheric fields after an eruption suggests that the actual restructuring of the field occurs high in the solar atmosphere where the magnetic forces dominate. Significant restructuring of the corona is often observed before, during, and after these events.

Vector magnetic flux measurements are required to determine the configuration of the surface magnetic fields. While **longitudinal magnetograms** provide some indication of the field's complexity, vector magnetograms in the photosphere (and ideally the chromosphere where the fields are closer to a force-free state), are required to determine the presence and magnitude of the magnetic stresses associated with these eruptions. Useful observations require adequate spatial resolution (~ 1 arcsec) to resolve the small-scale elements that may trigger the eruptions, adequate temporal resolution to follow the evolution (minutes) and the spatial and temporal coverage to capture all events and to determine long-range interconnections between magnetic regions.

Atmospheric images are required to determine the configuration of the magnetic fields in the lower corona associated with flares and CMEs. These images provide direct evidence of the occurrence of these events and provide critical information on their spatial, temporal, and physical characteristics.

Coronagraphic images are required to determine the configuration of the magnetic fields in the outer corona associated with flares and CMEs. These images also provide direct evidence of the occurrence of these events and provide critical information on their spatial and temporal characteristics.

UV/EUV spectra are required to determine the physical conditions at the site of the eruption – both before and after the events themselves. These measurements may help to identify the triggering events for these eruptions.

Helioseismic images are required to measure the surface and sub-surface flows asso-

ciated with the magnetic field pattern evolution.

Is the magnetic helicity removed from the Sun by CMEs consistent with the rate of helicity generation under the surface and with the rate of helicity transport in the solar wind? The Sun has a weak preference for left-helical fields in the north and right-helical fields in the south but the cause of this hemispheric pattern is not yet understood. Measurements of the patterns and the net amount of helicity generation would place important constraints on solar dynamo models. From a global point of view, CMEs are an inevitable response to helicity generation, but we do not know whether the helicity is primarily generated by the dynamo, by convection, or by shearing of coronal fields. A better understanding of helicity generation and removal is crucial to understanding CMEs.

Can the magnetic field direction and twist of CMEs be related to their geoeffectiveness? The direction of the interplanetary magnetic field in the solar wind is known to be a good indicator of the geoeffectiveness of the disturbance. To what extent can this field component be determined from observations of CMEs close to the Sun?

Vector magnetic flux measurements are required to determine the helicity of the surface magnetic fields.

Atmospheric imaging and UV/EUV spectroscopy can provide information on the sign of the magnetic helicity, and the field geometry for the twisted magnetic fields in CMEs.

Where do CMEs form shock waves, and how are coronal shocks related to the fluxes of energetic particles at the Earth? Energetic particles are accelerated in shocks

associated with CMEs. The locations and development of these shocks must be studied in more detail.

EUV coronal spectroscopy would provide important information on the physical conditions inside of CMEs as they evolve during their transit through the outer corona. Velocity distributions, line of sight velocities, and the detection of high temperature spectral lines can be used to determine shocks and current sheets within CME structures.

What is the role of magnetic reconnection in the heating and acceleration of CMEs? Some models of CMEs give a prominent role to a reconnection current sheet connecting the CME flux rope to a post-CME flare arcade.

UV/EUV spectra can provide evidence of extremely hot structures at the reconnection sites with observations of high temperature spectral lines and measurements of the plasma temperature, density, and heating rate. The presence of predicted MHD waves created at reconnection sites can be detected by their effects on observed spectral line profiles for comparison with models of the reconnection process.

3.1.3 Coronal Structure and Solar Wind Variations

Solar wind variations also produce geomagnetic disturbances. This is particularly evident late in each solar cycle when flares and CMEs are less likely and the Sun's global field geometry is more stable. As the Sun's rotation brings around the sources of high-speed streams we see recurring geomagnetic disturbances at ~27-day intervals (Fig. 3.6). Corotating Interaction Regions (CIRs) form within the heliosphere when such streams interact with ambient slow solar wind. These

interactions eventually include the formation of shocks that accelerate particles which contribute to the space weather environment.

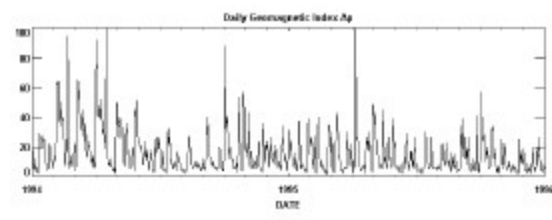

Figure 3.6. Geomagnetic fluctuations during the declining phase of Cycle 22. Disturbances recurring at 27-day intervals are due to high-speed streams in the solar wind.

3.1.3.1 Coronal Structure and Solar Wind Variations – Current Understanding

In the high-temperature, low-density extended corona the plasma beta (ratio of gas pressure to magnetic field energy density) is low enough that motions of the coronal plasma are usually dominated by the magnetic field configuration. We know that the high-speed wind originates in the open magnetic field regions in coronal holes and that the slow-speed wind emanates from above streamers.

Magnetic field extrapolation models, using photospheric magnetic fields as input, can now fairly reliably reproduce the large-scale structure of the inner corona (Fig. 3.7). These models have become more sophisticated by including non-potential fields and MHD effects. Maps of regions where the magnetic field is opened to the heliosphere correspond well to coronal holes and the source of high-speed wind streams. Yet, the physics involved in the heating of the corona and the acceleration of the solar wind is still hotly debated.

While much has been learned in recent years about coronal heating and solar wind variability, no unifying theory about the physi-

cal mechanisms responsible has emerged. Theories of coronal heating and solar wind acceleration generally fall into two broad categories: (1) heating and acceleration by Alfvén or other MHD waves and (2) heating and acceleration by the impulsive release of energy at sites of magnetic reconnection. Observations from current solar missions (e.g. SOHO, *Yohkoh*, and TRACE) have provided evidence for both types of mechanisms.

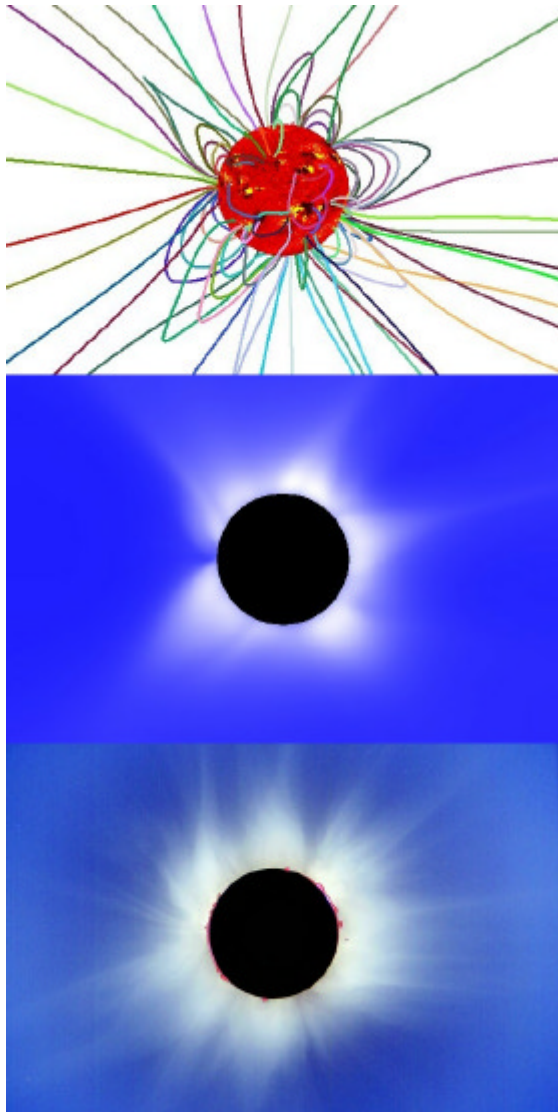

Figure 3.7. Coronal structures derived from an MHD field extrapolation model (top and middle panel, SAIC) for the August 11, 1999 eclipse (bottom panel). There are good agreements with many struc-

tures in spite of the lack of complete (back side) magnetic field information.

While Alfvén waves with frequencies high enough to probe cyclotron resonances (10 to 10,000 Hz) have not yet been observed directly in the solar wind or corona, UVCS coronal hole observations have given rise to renewed interest in the theoretical investigation of resonant wave dissipation. Spectral line widths indicating large anisotropic ion velocities have been observed. It is not known if the fluctuations originate primarily at the coronal base or are generated continuously in the acceleration region of the wind (via turbulent cascade or plasma instabilities).

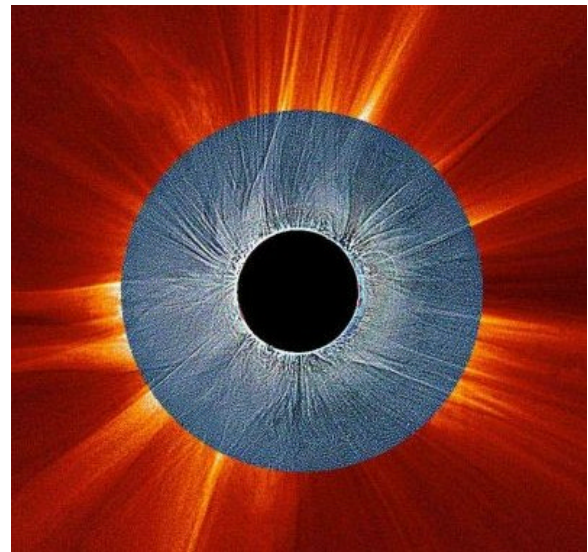

Figure 3.8. Coronal structures from 1.0 to $> 5 R$ (August 11, 1999 LASCO C2 image and total eclipse photo from S. Koutchmy). Solar wind speed can be measured using moving features in the outer corona but much of the restructuring takes place much closer to the surface.

SOHO/MDI magnetogram observations suggest that a “magnetic carpet” of twisted magnetic fields that reconfigure on timescales of minutes may be responsible for heating the quiet corona. Thin current sheets are generated between the twisted and braided field lines, and magnetic reconnection

tion occurs stochastically to relax the system to a lower-energy state (with net particle heating). “Microflares” from the reconnection sites on small loops seen in *Yohkoh*/SXT images and vector magnetograms may provide enough energy to heat the corona at least locally in active regions. Whether these local heating processes can heat the extended corona above a few tenths of a solar radius is still an open question.

Recent progress has also been made on the slow speed wind and its relation to coronal streamers. UVCS observations of high temperature ions high in streamers suggest preferential heating of ions with high mass-to-charge ratios. These results, while not conclusive, are consistent with ion cyclotron resonance absorption that could lead to a steady expansion of material into the slow speed wind. Other streamer observations made with LASCO show moving “blobs” or density enhancements that appear to emerge from the tips of streamers. This suggests that some of the mass in the slow speed wind is released by intermittent reconnections of the open and closed magnetic field lines in streamers. This view is consistent with the results of earlier investigations that link the origin of the slow speed wind to the streamer belt. However coronal abundance measurements show that most of the slow speed wind probably originates from the streamer edges, since these regions have similar depletions of high First Ionization Potential (FIP) elements that are found in the slow speed wind. More detailed measurements are needed to establish, with confidence, what fraction of the slow speed wind comes from streamer edges versus the closed-field regions of streamers.

3.1.3.2 Coronal Structure and Solar Wind Variations – Outstanding Questions

Can the structure and dynamics of the solar wind be determined from the magnetic field configuration and atmospheric structure near the solar surface? The temperatures and outflow speeds of the large polar coronal holes at solar minimum have been shown to differ from those of the coronal holes that appear primarily at low latitudes at solar maximum. For the low-speed wind, the large equatorial streamer belt at solar minimum seems to be hotter than the more sporadic streamers that form at all latitudes at solar maximum. Precisely how these thermal changes depend on the coronal field morphology is not well understood. The solar corona as a whole is brighter in its EUV emission at solar maximum than it is at solar minimum. Whether this arises because of an overall density increase, a change in the radial and latitudinal distribution of coronal heating, or is related to photospheric brightness changes, is not yet known.

Magnetograms are required to determine the configuration of the surface magnetic fields associated with the coronal and solar wind structures. Magnetic measurements at the boundaries between streamers and coronal holes will elucidate the role of open and closed fields in producing the slow speed wind. Longitudinal magnetograms are the minimum required observation, and to fully support the science outlined above vector photospheric magnetic flux measurements are required. While longitudinal magnetograms provide some indication of the field configuration, vector magnetograms in the photosphere, and ideally in the chromosphere where the fields are closer to a force-free state, are required to provide a more accurate determination.

Atmospheric images are required to reveal the location, morphology, and thermodynamic characteristics of atmospheric features associated with the outer coronal structures. The locations of polar plumes and the edges of streamers can be identified in such images. They also assist in the determination of the magnetic field configuration.

Coronagraphic images are required to determine the positions of streamers and coronal holes, the solar wind speeds associated with them, and to follow their evolution.

UV/EUV spectra are required to determine the physical conditions associated with the solar wind structures. Temperatures, densities, flow speeds, and the presence of waves and turbulence need to be determined within these structures. Spectroscopic measurements of bulk coronal outflow velocities at the boundaries between streamers and coronal holes will elucidate the role of open and closed fields in producing the slow speed wind.

EUV coronal spectroscopy would also provide important information on solar wind structures. Velocity distributions of ions and electrons could be measured to determine the spectrum of waves and turbulence in coronal structures. Doppler shifts and ion abundances could be measured to characterize the source regions of the high-speed and low-speed solar wind structures.

Helioseismic images are required to measure the surface and sub-surface flows. These flows control, to some extent, the magnetic field pattern evolution and the subsequent restructuring of the corona and solar wind.

What are the fundamental processes responsible for the heating and acceleration of the high-speed and low-speed solar

wind? Solar wind variations have a direct impact on space weather. We must better understand the processes involved in producing these variations. Heating and acceleration of the corona is ultimately related to the magnetic field. Observations are needed to differentiate between the alternative mechanisms of MHD wave absorption and impulsive Joule heating. Different proposed mechanisms of wave generation (i.e., turbulent cascade or local micro-instabilities) depend in different ways on the evolving coronal flux tube area, photospheric field strength, and plasma beta.

UV/EUV Spectra are needed to characterize the density, bulk velocity, energy state, ionization, and elemental abundance of solar wind source regions. A key means of identifying the dominant physical processes will be to observe how the measured plasma parameters and inferred wave properties evolve on timescales from days to solar cycles. Reconnection sites on the boundaries of streamers can be identified by measuring spectral line widths in these regions. Magnetic reconnection sites should also produce ions in highly excited charge states and their characteristic spectra.

3.2 Mechanisms of Solar Variability

Magnetic structure is produced in the Sun through a broad range of spatial and temporal scales. The global field reverses on a solar cycle timescale, while magnetic elements at the limit of resolution evolve on timescales of minutes or seconds. Ultimately, the source of this magnetic activity can be traced to the heat released by nuclear reactions in the solar core. However, the mechanisms by which the activity is produced involve the fluid flows driven by this heating and the magnetic field itself. Our ability to understand and ultimately predict solar ac-

tivity hinges on our understanding of how these magnetic structures are produced. Predictions of the size and timing of the next solar cycle will not be reliable until we understand how the cycle is produced. Predictions of flares and CMEs will not be reliable until we understand how active regions form and evolve. Predictions of solar wind variations will not be reliable until we understand how the wind is accelerated. SDO will provide crucial observations needed to improve our understanding of the mechanisms that produce solar magnetism.

3.2.1 The Solar Cycle

The solar cycle has proven notoriously difficult to predict. Once a cycle is well underway its smoothed behavior can be predicted with some reliability using statistical models for the shape of the cycle. Predictions prior to the start of a cycle are, however, much less reliable and longer range predictions are virtually useless. Currently, all methods of cycle prediction are empirical in nature. While we understand many of the processes involved in producing the solar cycle we do not have a physical model that will take initial conditions and predict future behavior. Long-range predictions of the solar cycle (as well as extensions backward in time) are important for understanding the climate connection, for predicting satellite drag, and for predicting the frequency of eruptive events such as flares and CMEs. SDO will improve our understanding of the solar cycle by providing continuous observations and extended spatial coverage of the two main components of the solar cycle – the magnetic field and the fluid flows within the Sun.

3.2.1.1 The Solar Cycle – Current Understanding

The solar cycle is a magnetic cycle in which the polarity of sunspots and the Sun’s global magnetic field reverse approximately every 11 years (Fig. 3.9). The source of this magnetic cycle is widely believed to be a magnetohydrodynamic dynamo seated within the solar interior. Magnetic fields are effectively “frozen” into the highly conducting ionized plasma within the Sun. Shearing motions within the plasma can amplify the embedded magnetic field. Regions with strong magnetic field become buoyant in the convection zone and rise rapidly to the surface. Magnetic loops emerge at the surface to form bipolar active regions with a characteristic tilt imposed by the solar rotation that leaves the following polarity closer to the poles than the leading polarity. At the surface a meridional flow slowly transports magnetic elements from the active latitudes to the poles while cellular flows like supergranules disperse them randomly across the surface.

The cycle is completed through magnetic reconnection between elements of opposing polarities. These ingredients (rotation, shear flow, meridional flow, cellular flows, rising tilted loops, and reconnection) are thought to be critical components of the dynamo. Observations and theoretical models exist for each of these but conflicts and questions remain and a comprehensive model containing all these ingredients is yet to be formulated.

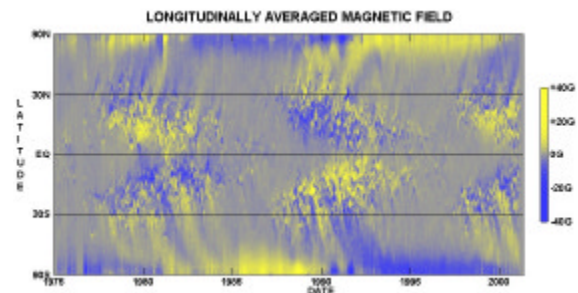

Figure 3.9. Longitudinally averaged magnetic field as a function of latitude and time. Active region magnetic flux is evident in the “butterfly” pattern within about 50° of the equator. The reversal of the magnetic polarities from cycle-to-cycle is evident at the poles and in the equatorward edges of the butterfly patterns.

The well-known differential rotation seen on the surface of the Sun is one example of a shear flow – latitudinal shear. Radial shear has long been thought to be the principal driver for the dynamo. Early kinematic dynamos for the Sun required a radial shear from a rotation rate that increased towards the interior while hydrodynamic models of the convection zone gave a rotation rate that decreased. Both of these models were shown to have problems when helioseismic observations revealed the true nature of the internal rotation profile. The rotation rate is nearly constant across the bulk of the convection zone with the shear layers at the top and bottom. The region of high shear found at the base of the convection zone (Fig. 3.10) is thought to be the source of the solar cycle. The rate of shear across this “tachocline” can wrap a magnetic field line once around the Sun’s equator every 16 months. Recent observations suggest that there is a periodic variation in the rotation rate at the tachocline with a timescale of 1.3 to 1.8 years. Others analyzing the MDI and GONG data only find evidence for chaotic variations. Should there be additional time periods associated with the solar cycle, the constraints on models will tighten.

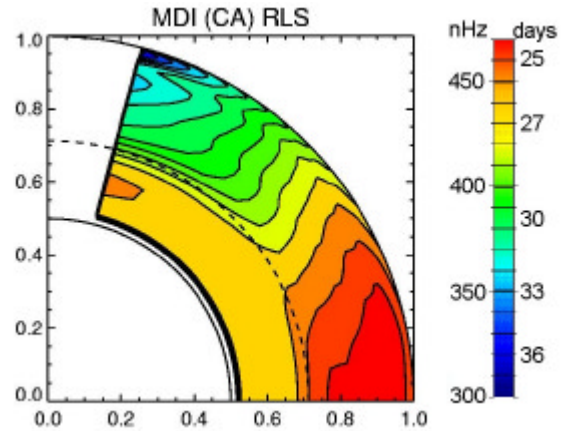

Figure 3.10. Internal rotation rate as a function of latitude and depth. The tachocline (dashed line - where the rotation velocity changes rapidly) is thought to be the location of the magnetic dynamo associated with the 11-year cycle.

The torsional oscillation pattern represents a shear flow on a smaller scale. Bands of enhanced rotation rate appear near the poles and migrate toward the equator by the middle of each cycle. This torsional pattern produces enhanced latitudinal shear in the active latitudes. The detection of the torsional pattern in the outer 5 percent of the Sun’s radius by helioseismic probing makes it evident that the structure is more than a superficial process. In layers below this outer 5 percent, the nature of the velocity structures becomes more obscure.

A meridional flow is observed both on the surface and in the interior. The strength of this flow, its latitudinal structure, and its variations in time are still somewhat uncertain. Tracking features on the surface gives a flow speed about half that given by the directly observed Doppler velocities. Helioseismic studies also give higher flow speeds and show that the poleward flow extends well into the convection zone. “Flux transport” models for the large-scale surface magnetic field have been developed over the last 40 years. These models do a remarkable job of reproducing the magnetic flux distribution using only surface flows and the

eruption of magnetic flux in active regions. However, the meridional flows employed in these models are quite different from the observed flows in both strength and structure. There are serious concerns about why the models of the polar cap size and field strength work as well as they do given that the poleward flow systems vary as much as is observed.

The hierarchy of velocity structures in the Sun begins with differential rotation and meridional circulation at the largest scale. At smaller scales is the torsional oscillation pattern. Superposed on the torsional oscillations is a persistent cell-like or wave-like pattern with a geometric scale of roughly 10 percent the solar diameter. At still smaller scale are supergranules. The supergranule pattern dominates the smaller scale distribution of the magnetic field and clearly plays a role in moving magnetic flux across the surface.

3.2.1.2 The Solar Cycle – Outstanding Questions

What mechanisms drive the quasi-periodic 11-year cycle of solar activity? This key question leads to others directly concerning the relevant processes themselves – differential rotation, meridional circulation, torsional oscillations, and cellular flows.

How are variations in the solar cycle related to the internal flows and surface magnetic field? The amplitude of the solar cycle can vary dramatically from one cycle to the next. Can we identify an early indicator of solar cycle magnitude? We expect these variations to be related to differences in the internal flows (e. g., differential rotation and meridional flow) and the magnetic field itself (e. g. polar field strength).

How is the differential rotation produced? The processes that produce the differential rotation are still uncertain. Hydrodynamical models for the solar convection zone reproduce the latitudinal differential rotation but not its variation with depth or time. Within these models the differential rotation is maintained by angular momentum fluxes driven by large-scale convective flows. The detection of these cellular flows and confirmation of the presence of the momentum flux would help our understanding of the solar cycle.

What is the structure of the meridional flow and how does it vary? The meridional flow itself has been exceedingly difficult to measure. Its form, in both latitude and radius, is still quite uncertain and its time dependence is unknown. The poleward surface flow extends well into the interior but the equatorward return flow has not been detected. Better characterizations of the meridional circulation will aid our understanding of the solar cycle.

What role does the torsional pattern play in the solar dynamo? The extension of the torsional oscillation pattern well below the surface suggests that this phenomenon is more than a small perturbation in rotation due to the presence of active region magnetic fields at the surface. While it is probably not the driving force behind the dynamo, it may very well play a significant role in that process and may signal variations in the behavior of the solar cycle.

Are the small latitudinal surface brightness variations related to the torsional pattern or the meridional flow? Latitudinal bands of enhanced surface brightness are seen in MDI data and the extreme polar regions appear darker. These features may be a thermal signature related to the meridi-

onal circulation or the torsional pattern. Changes in their structure and position may hold important clues to understanding the solar cycle.

Magnetic Images are needed to follow the evolution of the surface magnetic field. The magnetograms themselves should cover the visible disk to allow mapping the field to all latitudes and longitudes. The sensitivity should be sufficient to follow changes in quiet areas as well as in active regions and to accurately measure the polar flux.

Helioseismic Images are required for studies of the structures and flows in the solar interior. Helioseismic probing of the critical near surface layers (a region that all acoustic waves travel through and, because of the lower sound speed, spend much of their time in) requires high spatial resolution and rapid cadence observations. Probing of the three-dimensional structures deep in the convection zone requires good spatial resolution near the limbs to allow for widely separated measurement areas.

Atmospheric Images are needed in conjunction with the magnetograms to determine the large-scale magnetic field configuration associated with the solar cycle.

Coronagraphic Images are also needed in conjunction with the magnetograms to determine the large-scale magnetic field configuration associated with the solar cycle.

Photometric Images are needed to determine the actual source of the solar cycle variations in irradiance. These images may also reveal thermal structures associated with the solar dynamo process.

3.2.2 Active Region Evolution

Active regions are the most visible evidence of solar variability. The intense magnetic fields in active regions are the source of flares and most CMEs. The chromospheric and coronal structures that accompany active regions are the source of irradiance variations in the UV, EUV, and X-rays. Understanding and predicting the structure and evolution of active regions is key to our understanding and predictions of explosive events and spectral irradiance variations. Detection of emerging magnetic structures in the interior and understanding their physical properties can make important contributions to space weather forecasting.

3.2.2.1 Active Region Evolution – Current Understanding

The probability of the appearance of an active region can be given as a function of the size of the region for a given latitude and the phase and amplitude of the solar cycle. The number distribution of active region flux has been well measured through the solar cycle. It is an exponential function of the flux that does not change slope over the solar cycle. The amplitude of the function, and hence the total active region flux, changes by about a factor of eight from solar minimum to maximum depending upon the amplitude of the cycle.

Once an active region emerges, there is a high probability that additional eruptions of flux will occur in the neighborhood, or even in the same region (activity nests, active longitudes). There is some weak evidence that activity tends to concentrate around the edges of giant cellular patterns. Once an active region starts to become visible, its ultimate size and complexity can be estimated by the rate of flux growth and the complexity of its early appearance. However, none

of these predictions are based on physical models for the emergence of active region flux. There is a clear need for a better understanding of active region formation.

The source of the active region flux is thought to be in the tachocline, the shear layer just below the convection zone. Differential rotation should amplify the field until the magnetic energy density is so large that it becomes buoyant and rises to the surface. The magnetic fields must be amplified to about 10^5 Gauss to become sufficiently buoyant to begin their rise. Typically, active region magnetic flux emerges through the surface in the form of sunspot groups and plage. The spots grow in size over the course of days while the preceding and following spots drift apart in longitude. Active regions have characteristic tilts with respect to lines of constant latitude and asymmetries in the morphology of the preceding and following spots.

Models of buoyant flux tubes have been constructed to follow their rise from the bottom of the convection zone to within about 10,000 km of the solar surface. Above that height the rate of change of pressure is so great that current computers are not sufficient for the calculations required. (Six of the fifteen scale heights between the bottom and top of the convection zone occur in the top 10,000 km.) These models show how the effects of solar rotation can produce active regions with both tilt and morphological asymmetry between preceding and following spots. However, these models neglect the turbulent motions within the convection zone. Even neglecting turbulence it is difficult to create a stable rising flux bundle.

Observations of the interior rotation (Fig. 3.10) show that there is a sharp decline in the angular rotation rate over the top 10,000 km of the convection zone. Given the high shear between the surface and the deeper

convection zone it is hard to understand how the active regions that result from flux emergence can long remain connected to their origin in the tachocline.

MDI high-resolution measurements have demonstrated that it is possible, using time-distance helioseismology and acoustic tomography, to form images of the critical top 10,000 km. Time sequences of such images should do much to increase our understanding of active region flux emergence and the subsequent detachment of this flux from the deep convection zone. The behavior of the flux in the top 10,000 km of the Sun may be key to the understanding of the solar dynamo process that generates the active region flux.

As to the prediction of specific active regions at specific times and places, very little can be done at present. Searches for thermal shadow precursor signals in advance of the eruption of an active region have been inconclusive using currently available observations. Helioseismic tomography can be used to probe the flow field beneath active regions (Fig. 3.11). These techniques might detect emerging active structures in the deep interior before they are visible. However, a clear case of a precursor signal has not been observed. Initial results using the MDI high-resolution data indicate that the flux propagates rapidly, in less than 8 hours, through the top 10,000 km of the convection zone. One could speculate that this rise time is sufficiently rapid and the cadence of existing observations is too slow to detect a precursor signal. Alternatively, the precursor signals may simply be too weak to detect. Surface Doppler measurements do, however, show persistent convergence at the sites of active regions prior to their emergence. These observational techniques provide great promise for furthering our understanding of active regions.

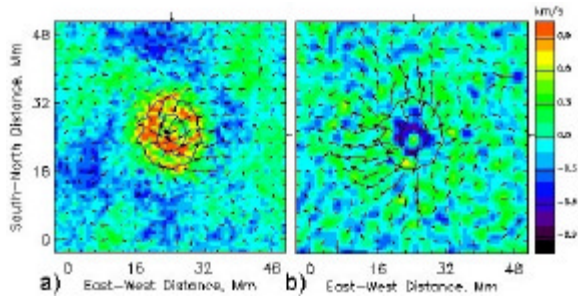

Figure 3.11. The material flows at the depth of 0-3 Mm (a) and at 6-9 Mm (b). The outline of the sunspot umbra and penumbra is shown. The colors are vertical motion with positive values (red) corresponding to downflow. The arrows are horizontal motion. Measurements like these may reveal active regions before they emerge.

Another recent success is the new ability to make crude images of sound speed anomalies near the surface on the far side of the Sun (Fig. 3.12). Thus, it has become possible, in principle, to predict that a large active region will rotate onto the visible disk days to weeks before this happens.

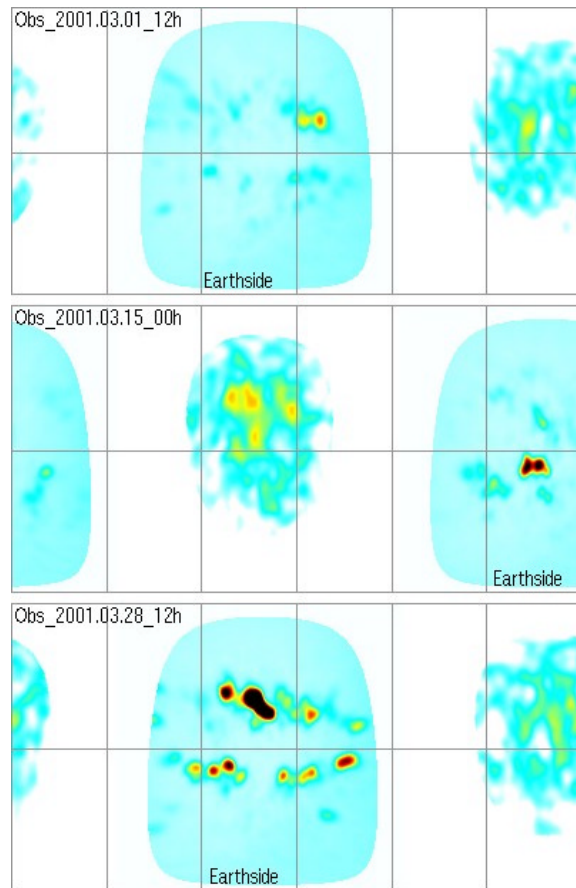

Figure 3.12. Helioseismic maps of the Sun. This set of three maps constructed 13.5 days apart shows that the “big spot” (AR9393) was seen on the far side before it was seen on the Earth side.

3.2.2.2 Active Region Evolution – Outstanding Questions

How is magnetic flux synthesized, concentrated, and transported to the solar surface where it emerges in the form of evolving active regions?

Can active region magnetic flux be observed before it erupts through the surface? Helioseismic studies can see changes in the sound speed below active regions but have not seen these variations before they erupt through the surface.

To what extent are the appearances of active regions predictable? An important goal for SDO is to develop an understanding of the locations and times of magnetic region eruption that goes beyond simple statistics. Can we go beyond empirically identifying the locations of activity?

What roles do local flows play in active region evolution? Some aspects of active region evolution are obviously dependent upon the characteristics of the emerging flux itself. Other aspects depend upon the surrounding flows that are themselves influenced by the presence of the active region.

Magnetic Images are required to determine the configuration of the surface magnetic fields associated with active regions. Vector magnetograms are required to provide a realistic assessment and to indicate the presence of electrical current systems and non-potential magnetic field systems. Vector magnetograms will also give evidence as to whether flux leaves the surface predominantly as bubbles, or whether it is principally the outcome of local annihilation of fields of opposing polarity. High cadence MDI observations have shown that the magnetic configuration changes in intervals as short as minutes. Therefore the fields must be measured on a comparable cadence in order to separate temporal and spatial variations.

Helioseismic Images are needed to construct subsurface maps with sensitivity and turnaround time superior to present capabilities. We also need helioseismic mapping of the far side of Sun with fast turnaround time. Helioseismic probing of the critical near surface layers (a region that all acoustic waves travel through and, because of the lower sound speed, spend much of their time in) requires high spatial resolution and rapid cadence observations. Probing of the three-

dimensional structures deep in the convection zone requires good spatial resolution near the limbs to allow for widely separated measurement areas.

Atmospheric Images are needed in conjunction with the magnetograms to determine the magnetic field configuration associated with active regions and their evolution. Simultaneous observations in several temperature regimes are needed to follow the evolution of the overlying loop systems. The rapid evolution (seconds) of these loops requires rapid cadence.

Coronagraphic Images are also needed in conjunction with the magnetograms to determine the magnetic field configuration associated with active regions and their evolution.

Photometric Images may reveal thermal structures associated with the active regions before they emerge.

UV/EUV Spectra are needed to provide information on the physical characteristics of atmospheric structures within active regions. These measurements may provide important information on reconnection events associated with the evolution of active region magnetic fields.

3.2.3 Small-Scale Magnetic Structure

While the large-scale distribution of magnetic flux on the Sun determines the coupling from the Sun to the heliosphere, the small-scale mixed polarity flux may provide most of the energy that heats the corona. In order to understand the distribution of fields on the Sun we must identify the types of sources of magnetic flux, the mechanisms for the spreading the flux, and the manner in which flux disappears from the surface. The

various mechanisms of flux disappearance are key to understanding the local heating of the outer atmosphere, the acceleration of the solar wind, and the contribution these elements make to the solar irradiance variations.

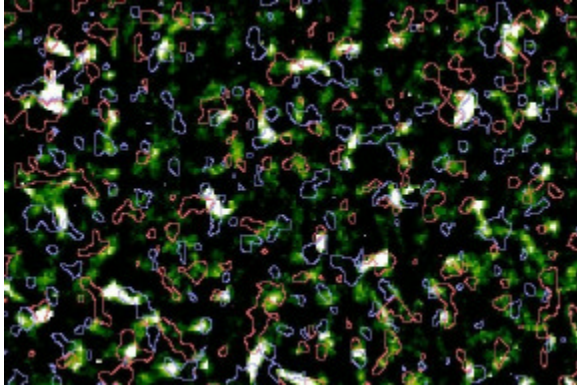

Figure 3.13. Small-scale magnetic elements (red and blue contours) and the coronal network bright points (SOHO/EIT image). The bright coronal features are well correlated with magnetic elements in general and magnetic dipoles in particular.

3.2.3.1 Small-Scale Magnetic Structure – Current Understanding

Away from active regions, most of the photospheric magnetic flux appears to exist in the form of flux tubes. These structures have complex dynamics. They form when a sufficient amount of flux is aggregated by local velocity flows to affect the transport of thermal energy. A cooling and subsequent collapse of the mass in the tube leads to a compression of the field into a kiloGauss-strength configuration. This structure persists until torn apart by convection.

An unknown amount of flux exists outside of active regions and the strong flux tubes. Some estimates indicate that the total flux may be as much as or more than that contained in active regions over the solar cycle. This pattern of mixed polarity has been

characterized as a “salt and pepper” pattern or the “magnetic carpet”. How it is created, how it evolves, and how it is destroyed are all uncertain. Presumably it is a manifestation of a local dynamo at work in the upper photosphere, but its relation to other scales of magnetic activity is not known.

Observations during the last few years have established that a significant fraction of the observed flux on the solar surface emerges in ephemeral regions – bipolar regions with lifetimes of hours. The ephemeral region number distribution, like the active region number distribution, is also exponential. Although it has not been as well measured as the active region flux over the cycle, there is strong indication that the amplitude of the cyclic variation is a factor of two or less. Consequentially, the ratio of total active region to ephemeral region flux varies considerably during the cycle. Another component of the flux is the inter-network field. This component has not yet been well characterized. There is evidence that the field strength of the inter-network field is 500 Gauss or less, while the active region and ephemeral region magnetic structures, excluding sunspots, have field strengths of 1100 ± 100 Gauss.

When active region flux emerges it forms plage as well as sunspots. Plage are regions in which the average magnetic flux is 125 ± 25 Gauss. Since the typical magnetic elements in plage have field strengths of about a kilogauss, the magnetic filling factor for plage is about 12%. Quite remarkably, plage maintain their average field strength as the active region grows and finally disappears. Outside plage, in the quiet Sun, the average field flux is about 5 Gauss. Because about 90% of the flux in the quiet Sun also has field strength of a kilogauss, the quiet Sun filling factor is about 0.5%. Subsurface imaging should collect data that will allow in-

sights into the structure of the flow and magnetic fields below the plage that give raise to the remarkable bimodal character of plage and quiet Sun.

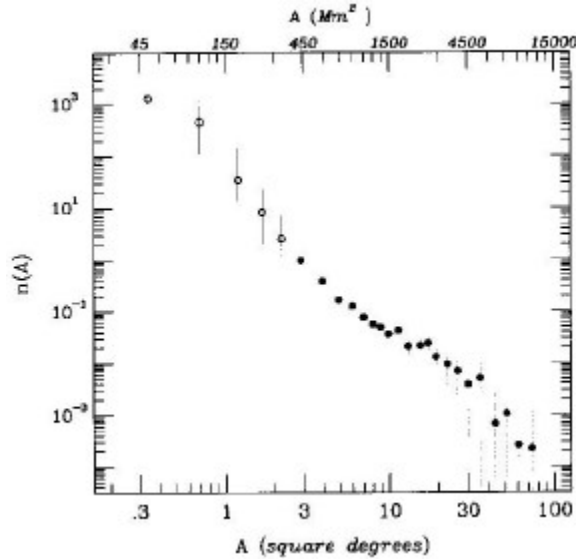

Figure 3.14. Histogram for the number of magnetic regions as a function of size (area). Ephemeral regions (open circles) appear as an extension of the distribution function for active regions (closed circles).

Once field elements leave the plage, they are dispersed over the surface by the diffusive action of convection, by the differential rotation, and by meridional flows. Linear models of flux distribution by diffusion, rotation, and flows have been developed over the past 40 years and have done an excellent job of predicting the mean characteristics of the surface flux distribution. In particular, given the observed plage strength, the mean field with a spatial resolution of a few arcminutes (see Fig. 3.9) and the mean field at the pole can be predicted. However, these models do not properly reproduce the number distribution of flux, the total flux with resolutions of a few arcseconds, or the spatial distribution of flux over the surface.

By proper choice of the value of the diffusion coefficient, the speed of the meridional

flow, and the latitude that the meridional flow terminates, these linear models produce remarkable agreement with low-resolution observations of the flux distribution over the surface. Unfortunately, the value of the diffusion coefficient that is required by the models is higher by a factor two than the measured values reported in the literature. This is not very serious because the majority of the measurement techniques for determining the diffusion constant strongly weight high concentrations of flux. Recent MDI observations have shown that the dispersal of flux is a function of the magnitude of the size of the flux concentration and that larger flux concentrations disperse more slowly than small ones. (Of course, these results mean that the uses of a fixed diffusion constant and consequently linear model of the surface spreading of magnetic field are not sufficient for an accurate description of flux dispersal.) Much more serious is that both the strength and the latitudinal structure of the meridional flow used in the models are not consistent with the observations. The poleward flow speed and the latitude of the upper cutoff control both the diameter and the magnetic flux of the polar cap field. There are strong indications from both ground and MDI measurements that these poleward current systems may also vary both in longitude and time.

Kinematic modeling that includes the supergranulation flow shows that there must be a constant eruption of new flux to maintain the measured total flux observed with a resolution of a few arcseconds. Constant eruption of flux is also required to maintain the observed quiet Sun network. Simulations show that the magnetic network would disappear in days without continuous replacement. The most recent measurements of the ephemeral flux emergence rate yields about $5 \cdot 10^{23}$ Mx/day, which is equivalent to 10 to 20 large active regions. This rate is

sufficient to replace the quiet Sun network in less than a day and the flux in an active region, if the emergence rate is the same as in quiet Sun, in a few weeks. Because the rate of emergence of ephemeral flux is so high, 10 to 30% of the quiet Sun flux may reside in the cell centers just because the travel time to the boundary is only a small fraction of the total flux lifetime on the surface.

Ephemeral region flux emerges inside supergranulation cells and is transported to the cell boundary where it cancels with existing flux in the magnetic network. This means that ephemeral flux is not just the result of magnetic loops emerging through and then sinking back below the solar surface. Rather ephemeral regions must disappear by some type of reconnection process. There are a number of methods for estimating the energy released in the reconnection. But using the initial field strength and the foot point separation of the emerging loop to estimate a magnetic volume energy, the result is 3×10^7 ergs/cm²/sec. This energy emergence rate is two orders of magnitude more than necessary to heat the corona, but most of the energy may be dissipated in the chromosphere and transition region.

There is clear evidence from very high-resolution filter magnetograms that magnetic field emerges on the scale of granulation. Spectropolarimetry indicates that there is a component of the field with a strength that is probably less than 500 Gauss, and that there is a significant amount of weak horizontal field in quiet Sun. Taken together these observations constitute a strong suggestion that there are surface magnetic fields associated with every form of convection. Numerical simulations indicated that a weak seed field is amplified sufficiently by convective flows to generate a mixed polarity field that contains 25% of the kinetic energy originally in the convection.

Local dynamo action is extremely interesting as a process that has the capacity to continuously generate energy that can then be used to heat the chromosphere, transition region and corona. In addition models suggest that local and global dynamos can couple and thus produce variations in the length and amplitude of the solar cycle.

3.2.3.2 Small-Scale Magnetic

Structure – Outstanding Questions

How does magnetic reconnection of solar magnetic fields on small spatial scales relate to coronal heating, solar wind acceleration and the transformation of the large-scale field topology? There are indications that the interactions between opposite polarity elements contribute to coronal heating. These interactions may also provide the triggers for eruptive events that restructure the large-scale field.

How are the small-scale magnetic features produced? There is now good evidence for magnetic dynamo activity in the thin layer just below the photosphere. There is strong shear across this layer and the rate at which magnetic flux appears and disappears suggests local generation.

What are the dynamics of magnetic structures on very small spatial scales? Several mechanisms may be involved in the appearance, disappearance, and interactions between these small magnetic structures. High-resolution vector magnetograms show that many magnetic elements seen in longitudinal magnetograms may just be intersections

of undulating flux ropes with the photosphere.

Magnetic Images are required to identify and to follow the evolution of these elements. Full-disk observations with enough spatial resolution (~ 1) to identify them will be needed to determine their characteristics. The temporal cadence should be fast enough to follow their evolution and interactions (~ 5 min is probably the best that can be achieved). Longitudinal magnetograms should be sufficient for most studies involving the small-scale magnetic elements but vector magnetograms will be required to understand the flux ropes forming the small-scale elements.

Helioseismic Images are needed to determine the nature of the fluid flows that surround these elements and to examine their sub-surface structure. Since flows close to the surface will be the most significant, the oscillation images will need the spatial (~ 1) and temporal (< 50 sec) resolution to resolve them and their temporal evolution.

Atmospheric Images are needed to determine the effects of these elements on coronal and chromospheric heating. These images should also have the spatial resolution (~ 1) to identify the elements and the temporal resolution (~ 10 sec) to follow their evolution. These images need to cover a wide range of temperatures to determine the effects of these elements on atmospheric heating and dynamics.

UV/EUV Spectra are needed to provide information on the physical characteristics of atmospheric structures above these small-scale magnetic elements. These measurements should provide important information on events associated with coronal heating by these magnetic elements.

4 Required Observations

An array of observations is needed to address the scientific questions posed for SDO. Each of these observations and their characteristics can be traced back to one or more of the outstanding questions stated in the previous section. (Note that all six of the scientific areas discussed in the previous Section are deemed critical to the SDO Mission. The scientific links among the different areas suggest that all would suffer from the omission of any one.) Since single instruments might be designed to provide more than one measurement (e.g., helioseismic images and magnetograms), we present the requirements for the measurements themselves in the following sub-sections. Potential instruments and the possible allocation of resources are given in Section 5.

All of these observations are important for one or more of the scientific areas to be addressed by SDO. However, some are deemed to be of higher priority than others for a variety of reasons. Some of these observations are either unique to SDO or have requirements that can be uniquely met by SDO (e.g. full-disk spatial coverage, continuous time coverage over several years, rapid cadence, high bandwidth). Other observations may be provided by other programs, may be more speculative in nature, or may be more difficult to obtain with current technology and resources. We recognize the need for setting priorities for SDO and have done so by grouping the observations and their respective instruments into three priority categories: **highest priority** – SDO must make these observations; **high priority** – due effort should be made to include these observations but for one reason or another (as discussed in the following sub-sections) the mission could go on without them; **important** – these would enhance the scientific

return from SDO but should not be included at the expense of higher priority observations.

The highest priority observations include (from the interior outward):

- Helioseismic Images
- Longitudinal Magnetograms
- Atmospheric Images
- EUV Spectral Irradiance
- Total Solar Irradiance (should concurrent measurements not be available from other platforms)

The high priority observations include:

- Photometric Images
- Vector Magnetograms
- UV/EUV Spectra
- Coronagraphic Images

The important observations include:

- Coronal Spectroscopy
- Heliometry

Further refinement of priorities within these groups is unproductive at this phase of the mission definition. The actual resources required to obtain the measurements, the actual instruments to be flown on other missions, and other programmatic considerations could easily change those priorities.

4.1 Helioseismic Images

Helioseismic images are required for studies of the Sun's internal flows and structures. This impacts all aspects of SDO science. Helioseismic images provide information on solar radius changes for irradiance studies (Section 3.1.1.2) and on sub-surface flows that drive magnetic field evolution associated with flares and CMEs (Section 3.1.2.2) and with coronal structures and solar wind variations (Section 3.1.3.2). Helioseismic images provide critical measurements of the internal flows that drive the solar cycle (Section 3.2.1.2), active region evolution (Section 3.2.2.2), and the dynamics of the small-scale magnetic elements (Section

3.2.3.2). One of the highest priorities for SDO is to obtain the helioseismic observations required to provide a detailed view of the upper 10-20 Mm of the convection zone. These measurements are of highest priority for SDO. They will not be available with the required spatial resolution and full-disk coverage from any other source.

Accuracy. Signals near the base of the convection zone likely generate wave travel time variations as small as 0.01 second. The total travel time approaches 2 hours so the timing accuracy must be on the order of a part in 10^6 over intervals of hours to days.

Dynamic Range. Previous experience shows that the best signal-to-noise can be obtained with Doppler observations as compared to brightness observations in the 1 to 5 mHz region. Therefore dynamic range is discussed here in terms of velocity. The instrument must have a velocity dynamic range large enough to accommodate both the spacecraft orbit and the Sun's rotation. The orbit will have a range of about 6 km/s and the Sun adds about 7 km/s from East to West limbs giving a dynamic range of about 13 km/s.

Time Cadence. There is useful wave power up to about 8 mHz and measurable power to at least 12 mHz. A sample with a 10 mHz Nyquist frequency leaves the spectrum clean up to 8 mHz. This gives a time cadence of about 45 seconds per measurement.

Spatial Resolution. A reasonable goal is to sample the wave-speed profile and flows with about 1 Mm depth resolution in the upper 10-20 Mm of the convection zone. This requires sample points 3 Mm apart. At 75° from disk center, this corresponds to about 1 arcsec resolution. This can be provided with 0.5 arcsec detector pixels.

Field Of View. In order to detect fields and flows nearer the base of the convection zone, we need simultaneous observations across the full disk (again 75° from disk center is a reasonable goal, this is 0.97 in units of the radius).

Completeness. Gaps in the data stream compromise the helioseismic objectives. Experience with MDI and GONG indicate that nearly complete coverage (more than 95% of the time) is needed.

Table 4.1: Measurement Characteristics for the Helioseismic Imager

Observable	Osc. Time Series
Accuracy (Clock)	10^{-6}
Dynamic Range	13 km/s
Time Cadence	< 50 sec
Spatial Resolution	1 arcsec
Field of View	Full Disk
Duration	10 years
Completeness	99.99% coverage 95% of time

4.2 Longitudinal Magnetograms

Magnetic images are critical for all of the scientific areas to be addressed by SDO. Longitudinal magnetograms are needed: to distinguish between magnetic and non-magnetic sources of the irradiance variations (Section 3.1.1.2); to determine the configuration of the magnetic fields associated with flares and CMEs (Section 3.1.2.2) and solar wind variations (Section 3.1.3.2); to follow the evolution of the magnetic field over the solar cycle (Section 3.2.1.2) and as active regions evolve (Section 3.2.2.2); and to identify and follow the small magnetic elements (Section 3.2.3.2). Longitudinal magnetograms are of highest priority to SDO. Full-disk, high-resolution magnetograms will not be obtained with the required tem-

poral resolution and coverage by any other means.

Precision. A pixel-by-pixel precision between 5 and 50 G over a 5 minute integration is needed to follow the evolution of the small-scale magnetic elements.

Accuracy. The disk integrated magnetic flux should be measured with an accuracy of about 0.1 G. This level of accuracy allows for studies of active region flux imbalances and determinations of the global field configuration.

Dynamic Range. Sunspot umbrae harbor the strongest magnetic fields with peak values of about 3000 G. A dynamic range of 6-7 kG would capture even the strongest flux concentrations.

Time Cadence. Individual magnetograms should be obtained at a cadence of at least 1 minute to account for the Doppler shifts due to the 5-min oscillations.

Spatial Resolution. High spatial resolution (~1 arcsec) is required to identify the small intranetwork magnetic elements.

Field Of View. Full-disk measurements are required to provide the global field configuration, to monitor all active regions, and to provide complete coverage for studies of irradiance and small magnetic features.

Table 4.2: Measurement Characteristics for the Longitudinal Magnetograph

Observable	Longitudinal B
Precision	5-50 G / 5 min
Accuracy	0.1 G
Dynamic Range	Several kG
Time Cadence	~ 1 min
Spatial Resolution	1 arcsec
Field of View	Full Disk
Duration	10 years

4.3 Atmospheric Images

Atmospheric images are required for all aspects of the SDO mission. They indicate the sources of the EUV irradiance variations (Section 3.1.1.2), the occurrence and nature of flares and CMEs (Section 3.1.2.2), and the structure and dynamics of the low corona (Section 3.2.3.2). They reveal the magnetic structures associated with the solar cycle (Section 3.2.1.2), active region evolution (Section 3.2.2.2), and small-scale magnetic elements (Section 3.2.3.2). These observations are of highest priority to SDO. Full-disk images at the required spatial and temporal resolution will not be obtained by any other means.

Precision/Accuracy. A photometric accuracy of about 10% is needed for these images to be useful as a tool for the determining the sources of the spectral irradiance. Similar accuracy is needed in making useful ratios of the images to determine physical characteristics of the atmospheric features. These imagers must be properly calibrated to insure the stability and repeatability of the measurements at the 10% level.

Dynamic Range. A high dynamic range (10^3 or greater) is needed to provide observations with sufficient signal to noise and to span the range of emission features from intra-network loops to bright active regions.

Time Cadence. An important diagnostic of coronal activity may lie with transient flow patterns that are perhaps created by short-term heating events. The flow velocities on the order of 100 km/s, near the sound speed, are often observed. A cadence of 10 seconds would be sufficient to track these flows from resolution element to resolution element between consecutive exposures.

Spatial Resolution. We know from measurements with HRTS and SUMER that the atmospheric structures are highly filamentary. TRACE observations show that with 1 arcsec spatial resolution, solar structures are recorded with sufficient clarity that much of the confusion produced by the fine structure is overcome. CCDs with a 4096x4096 format will soon become available and would provide a 1.2 arcsec resolution over the 40 arcmin field of view.

Field Of View. Full-disk images are required to observe flares and CMEs and to identify sources of EUV irradiance variability. CMEs are often large-scale events that can involve a significant portion of the solar disk. In addition, it would be useful to observe the initial acceleration of CMEs near the solar limb with some overlap with the coronagraph. Consequently, a field of view (FOV) of 40 arc-min ($1.25 R_{\text{Sun}}$) is specified.

Spectral Resolution. Relatively high spectral purity (resolving power of 20 or so) is needed so that the individual images refer to only a small temperature range.

Temperature Range. Solar activity often involves the nearly simultaneous rapid evolution of plasmas over a wide range of temperatures, such as hot flare plasmas, the eruption of cool prominence material and the reconfiguration of coronal loops during a flare or CME event. To understand the dynamics of the coronal field, we must be able to trace the loops as they evolve in temperature. That requires narrow pass bands because only those allow the clear identification of loops while minimizing the line of sight confusion. The ability of the Atmospheric Imagers to observe plasmas over a wide range of temperature (0.02 – 4 MK) will help untangle the relevant physical processes. The number of image bandpasses

needed to effectively span this range is uncertain. The minimum is probably four but seven would be far more useful.

Table 4.3: Measurement Characteristics for the Atmospheric Imagers

Observable	Intensity
Precision/Accuracy	10 %
Dynamic Range	$10^3 - 10^5$
Time Cadence	10 sec
Spatial Resolution	1.2 arcsec
Field of View	$40 \times 40 \text{ arcsec}^2$
Spectral Resolution	$\lambda/\Delta\lambda \sim 20$
Temperature Range	0.02 – 4 MK

4.4 EUV Spectral Irradiance

The EUV irradiance and its variations influence ionospheric and thermospheric composition, density, and temperature. The need for continuous observations of these variations (Section 3.1.1.2) drives the SDO requirements for an EUV Spectral Irradiance Monitor. These observations are of highest priority to SDO. While EUV spectral irradiance observations will be obtained by the SEE instrument on the TIMED mission, these observations will not be concurrent with the SDO mission and are of lower spectral and temporal resolution. The SDO EUV observations play a critical role in helping us to understand how solar variability influences the ionosphere and thermosphere. Tracking the solar cycle variations, and the possibility of longer-term secular variations is desirable. The observations should be obtained continuously to maintain a calibrated time series, and to provide continuous inputs for geophysical studies undertaken elsewhere within the LWS program.

Precision/Accuracy. The absolute uncertainty (accuracy) translates into uncertainties in geophysical parameters (densities, tem-

peratures) calculated by geophysical models that use these inputs, so the goal is maximum accuracy. Accuracies of 10% reflect the state of the art irradiance calibrations using synchrotron irradiance standards. Degradation of the optics and detectors forces a requirement for some on-board calibration as well. The measurements should have long-term stability on the order of 5% for useful solar cycle studies.

Dynamic Range. The solar cycle variability ranges from 50 percent to two orders of magnitude over this spectral range, with even larger variations (a factor of up to 1000 in some lines) occurring during flares. A dynamic range of about 1000 can be obtained with a combination of detector dynamic range and different exposures.

Time Cadence. Synchronization with the SDO Atmospheric Imagers is desirable for tracing the flux to the magnetic (and possibly other) sources of its variability and for formulating physical mechanisms. This indicates a similar time cadence of about 10 sec for the EUV irradiance measurements.

Field Of View. A slightly larger FOV than the solar disk will minimize pointing error problems. The FOV should be sufficient to capture off-limb radiation that may contribute to the flux of some hot coronal lines.

Spectral Resolution. Solar emission lines that are close in wavelength can nevertheless have quite different variabilities if they have different emission temperatures i.e., sources in different solar atmospheric regions. At wavelengths longer than 10 nm, line and continuum energy inputs to the upper atmosphere and ionosphere must be separately measured and distinguished to achieve the required geophysical understanding. AURIC (Atmospheric Ultraviolet Radiation and Ionization Code), which is used to calculate

photoelectron production and heating, requires input spectra with 0.1 nm resolution.

Spectral Range. Understanding ionospheric and neutral density responses to solar variability requires knowledge of the solar energy inputs over a spectral range from 1-120 nm in both lines and continua.

Table 4.4: Measurement Characteristics for the EUV Spectral Irradiance Monitor

Observable	Spectral Irradiance
Precision/Accuracy	10 %
Dynamic Range	10^3
Time Cadence	10 sec
Spatial Resolution	None
Field of View	1°
Spectral Resolution	$\Delta\lambda \sim 0.1 \text{ nm}$
Spectral Range	1 – 120 nm

4.5 Photometric Images

Photometric image data is essential to finding the origins of solar irradiance and luminosity variability (Section 3.1.1.2). These images may also reveal thermal structures associated with the solar cycle (Section 3.2.1.2) and active region evolution (Section 3.2.2.2). These observations are of high priority for SDO, as they address three important areas. Data of high photometric sensitivity or extended bandwidth will only be obtained from space and would be unique to SDO. However, empirical modeling of the sources of the irradiance variations suggests that the sources are well understood and helioseismic determinations of solar radius variations indicate that these variations probably play only a minor role in producing the irradiance variations. The ability to image thermal perturbations associated with active regions before they emerge is somewhat speculative but may prove to be revolutionary.

It is likely that the photometric mapper (PM) will operate with two channels. In its first channel it will achieve the highest possible photometric accuracy and spatial resolution. The second channel captures the widest possible spectral coverage (approaching total solar irradiance bolometric spectral coverage) with sufficient spatial resolution to identify photospheric magnetic contributions as small as faculae.

Precision. In its first channel the PM must have photometric stability and sensitivity sufficient to detect faint diffuse brightness changes associated with surface magnetic features like sunspot bright rings, facular shadows and the network irradiance perturbations. Detecting these subtle features will require a precision of about 0.1%. In its second channel the PM must have the ability to tally the contributions to the irradiance variations from the various photospheric features. A precision of 3% at each pixel should be sufficient for the number of pixels given by the spatial resolution requirement.

Dynamic Range. The dynamic range at each pixel should be sufficient to capture the range of intensities from the darkest sunspot umbrae to the brightest plage and faculae.

Time Cadence. The images should be obtained at about 1 minute intervals to resolve the *p*-mode oscillation component of the irradiance variations.

Spatial Resolution. Photospheric faculae should be resolved in these images. A spatial resolution between 1 arcsec and 10 arcsec should be sufficient.

Field Of View. The full photospheric disk must be imaged for the mapper to provide the observations needed to determine the sources of the irradiance variations.

Table 4.5 Photometric Mapper Characteristics

Channel	Photometric	Bolometric
Observable	Surface Intensity	Bolometric Intensity
Precision	0.1 %	3 %
Dynamic Range	$>10^3$	30
Time Cadence	1 min	1 min
Spatial Resolution	1 arcsec	10 arcsec
Field of View	Full Disk	Full Disk
Spectral Resolution	Narrow band	Broad band
Completeness	95%	95%

4.6 Vector Magnetograms

Vector magnetograms are needed to determine: the magnetic stresses and current systems associated with flares and CMEs (Section 3.1.2.2); the nonpotentiality of coronal magnetic fields (Section 3.1.3.2); and the large-scale magnetic field pattern evolution associated with the solar cycle (Section 3.2.1.2) and active region evolution (Section 3.2.2.2). These are high priority observations for SDO. They address critical needs in several areas. However, full-disk vector magnetograms with the required spatial resolution may be difficult to obtain with current technology and mission resources. Limited field of view observations at higher resolution will be acquired with instruments on Solar-B (Section 7.2). Full-disk measurements from the ground will be acquired with the SOLIS instruments (Section 7.6). These alternative observations do not, however, fully satisfy the SDO requirements. Solar-B has a very limited field of view and SOLIS will have poorer spatial resolution and temporal coverage.

Precision. The precision of the transverse field direction measurements should be a

few degrees. This translates into a polarization precision of $\sim 10^{-4}$. The precision of the field strength measurements should be better than 50 G for a 10-minute integration time.

Accuracy. The vector field measurements should yield the correct vector field direction in each resolution element to within five degrees. The longitudinal component accuracy should be consistent with a disk integrated flux accuracy of about 0.1 G.

Dynamic Range. Sunspot umbrae harbor the strongest magnetic fields with peak values of about 3000 G. A dynamic range of 6-7 kG would capture even the strongest flux concentrations.

Time Cadence. Polarimetric scans should be obtained at a cadence that allows the Doppler shifts due to the 5-minute oscillations to be removed or compensated for. Full-disk vector magnetograms should be obtained at a cadence of about 6 per hour.

Spatial Resolution. High spatial resolution (~ 1 arcsec) is required to identify the small magnetic elements.

Field Of View. Full-disk measurements are required to provide the global field configuration, to monitor all active regions, and to provide complete coverage for studies of irradiance and small magnetic features.

Table 4.6: Measurement Characteristics for the Vector Magnetograph

Observable	Vector B
Transverse Precision	50 G ($\sim 3^\circ$)
Polarimetric Precision	$\sim 10^{-4}$
Dynamic Range	Several kG
Time Cadence	~ 10 min
Spatial Resolution	1 arcsec
Field of View	Full Disk
Duration	10 years

4.7 UV/EUV Spectra

The UV/EUV Imaging Spectrometer will provide spectral images and measurements that reveal quantitatively the dynamics of the solar atmosphere, from the photosphere, through the transition region to the corona. The UV/EUV Imaging Spectrometer will provide quantitative constraints on the physical mechanisms associated with: the sources of the spectral irradiance variations (Section 3.1.1.2): the impulsive release of energy that results in flares and CMEs (Section 3.1.2.2); and the sources of high-speed and low-speed solar wind (Section 3.1.3.2). UV/EUV spectra are also needed to provide information on the physical characteristics of atmospheric structures in active regions (Section 3.2.2.2) and above small-scale magnetic elements (Section 3.2.3.2). These observations are of high priority to SDO. They are required to address several outstanding questions. Although there is an EUV Spectrometer planned for the upcoming Solar-B mission (Section 7.2), it is not ideally suited to the SDO scientific objectives for two reasons. First, the Solar-B EIS is primarily a coronal spectrometer, with only one strong emission line below 10^6 K. Second, the estimated count rates of the Solar-B EIS are too low to match the temporal cadence of the Atmospheric Imager Array. The SDO UV/EUV Imaging Spectrometer nicely complements the Atmospheric Imaging because it provides quantitative observations with the spatial and temporal resolution necessary to resolve ambiguities seen in the imager observations.

Precision/Accuracy. Spectral intensity should be measured to within 10% to contribute to the spectral irradiance studies. Line widths should be measured to within about 10% to provide useful information on non-thermal broadening associated with

physical mechanisms in the relevant features. Doppler velocities should be measured to within 1-5 km/s to determine the nature of the dynamic events.

Dynamic Range. Spectral intensity varies widely from one spectral feature to another and from quiet sun to active plage. A dynamic range of 10^3 to 10^5 should capture all these features.

Time Cadence. Ideally, the time cadence of the UV/EUV Imaging Spectrometer should match the 10 sec cadence of the Atmospheric Imaging Array. This can be accomplished with limited FOV raster motions about a given location (e.g. central meridian) or target (e.g. active region), repeated throughout the majority of the observing period. Synoptic observing programs providing raster images of the entire disk may also be performed periodically.

Spatial resolution. A spatial resolution of 1.3 arcsec should be sufficient to resolve the facular elements associated with the spectral irradiance variations.

Field Of View. The routine raster FOV will be limited by the necessity to match the time cadence of the Atmospheric Imaging Array. However, it will also be necessary to observe the full solar disk and inner corona by slit rasters or other techniques.

Spectral Resolution. A spectral resolution (resolving power) of 30000 should be sufficient to measure the required line profile information.

Temperature Range. The measurements should include spectral features that cover the temperature range of the Atmospheric Imaging Array – 0.02 to 4 MK.

Table 4.7: Measurement Characteristics for the UV/EUV Imaging Spectrometer

Observable	Line Profiles
Precision/Accuracy	Intensity 10 % Width 10% Velocity 1-5 km/s
Dynamic Range	$10^3 - 10^5$
Time Cadence	10 sec
Spatial Resolution	~1 arcsec
Field of View	16 to 34 arcmin
Spectral Resolution	$\lambda/\Delta\lambda \sim 30,000$
Temperature Range	0.02 – 4 MK

4.8 Coronagraphic Images

Coronagraphic images are important for many aspects of the SDO Mission. These images indicate the occurrence of CMEs (Section 3.1.2.2) and reveal the structure of the corona and presence of solar wind variations (Section 3.1.3.2). They also provide important information on changes in the magnetic configuration of the corona associated with the solar cycle (Section 3.2.1.2) and active region evolution (Section 3.2.2.2). The coronagraphic images are of high priority to SDO. They provide critical information on events and processes associated with several outstanding questions. However, the STEREO mission (Section 7.1) is designed to address many of these questions. Nonetheless, coronagraphic images from SDO will be needed to span the duration of the mission and provide information on the occurrence of CMEs and solar wind variations.

The SDO coronagraphic images will probably require two separate channels in order to map the structure of the corona from $1.1 R_{\text{Sun}}$ to $15 R_{\text{Sun}}$. The stray light suppression requirements are such that it is not practical for a single coronagraph channel to be used for the entire range of heights. Further, a de-

sired spatial resolution of 12 arcsec or better at the inner edge of the FOV ($1.1 R_{\text{Sun}}$) requires an internally occulted coronagraph system. The channel for the outer corona should provide overlapping coverage with the other coronagraph channel. That implies that this channel has to be an externally occulted system. The requirement for halo CME detection is a high priority for the LWS mission, in general, and SDO, in particular since these are CMEs that affect Earth and have their origins from regions directly observed on the disk with the Atmospheric Imaging instruments.

Precision. The polarization brightness should be measured with a precision of about 10% to provide useful information on coronal structures and their variations.

Dynamic Range. A dynamic range of about 10^3 captures most of the observed variations in the inner corona. A somewhat wider dynamic range of about 10^4 captures most of the observed variations in the outer corona.

Field Of View. An inner height of $1.1 R_{\text{Sun}}$ is required to overlap the FOV of the Atmospheric Imaging instruments and thus allow for continuous tracking of events like CMEs from their initiation in disk imagers through their development in the extended corona. An outer height of about $15 R_{\text{Sun}}$ is needed in order to allow detection of halo CMEs that are directed toward the Earth. Experience from LASCO observations shows that beyond $15 R_{\text{Sun}}$ the propagation properties of CMEs don't change much and so this outer limit would be acceptable.

Time Cadence. High time cadence will be required to study the dynamics of coronal disturbances (CMEs, streamer blowouts, eruptive prominences, etc.). SOHO/LASCO observations have shown that 1-min and 5-min cadences, for the inner and outer chan-

nels respectively, are required and sufficient for accurate determinations of liftoff times, helical motions, and speed profiles for different parts of coronal mass ejections.

Spatial Resolution. Observations of CMEs should have a high enough spatial resolution to discern their small-scale structures. Plumes and polar rays are on the order of a few arc-minutes in width but they have fine-scale structure on the sub arc-minute level that is probably related to their magnetic field configurations. A 2048×2048 CCD detector would give a spatial resolution of 6" for the inner coronagraph and 30 arcsec for the outer coronagraph. This would give SDO twice the resolution of LASCO C1 and a comparable resolution to C2; it is more than adequate to meet the SDO science requirements.

Table 4.8: Measurement Characteristics for the Coronagraph

Channel	Inner	Outer
Observable	Polarized Intensity	Polarized Intensity
Precision	10 %	10 %
Dynamic Range	10^3	10^4
Time Cadence	1 min	5 min
Spatial Resolution	6 arcsec	30 arcsec
Field of View	$1.1-3. R_{\text{Sun}}$	$2.5-15 R_{\text{Sun}}$
Spectral Range	400-700 nm	400-700 nm

4.9 Total Irradiance

The total solar irradiance must be accurately and precisely monitored to determine the nature and source of the irradiance variations (Section 3.1.1.2). These observations are of highest priority to SDO but will likely be obtained from both SORCE (Section 7.4) and GOES/NPOESS (Section 7.5) during

the SDO mission and are therefore not included as part of SDO. If, however, it appears that these observations will not be provided by these alternative sources then a Total Solar Irradiance Monitor should be placed on SDO.

Precision/Accuracy. The absolute uncertainty (accuracy) translates into uncertainties in the energy input to the terrestrial climate system. The goal is maximum accuracy to minimize uncertainties in climate models, and also to ensure that the instrument is properly characterized to achieve the needed high repeatability. The actual solar energy input to the radiometer depends on the entrance aperture, but is typically of order 100 milliWatt. The ability to measure the change in this signal due to changes in total solar irradiance depends, in part, on the noise floor of the radiometer electronics. This ratio sets the dynamic range and it must be sufficient to enable the required repeatability and uncertainty, at a cadence of 1 observation per minute.

Time Cadence. The 5-minute oscillations affect total solar irradiance, and the instrument must be capable of resolving these in time.

Duration. Tracking the solar cycle variations, and the possibility of longer term secular variations, is desirable.

Completeness. The instrument should be operated continuously to maintain a calibrated time series, and to provide continuous inputs for geophysical studies undertaken elsewhere within LWS.

Field Of View. A FOV slightly larger than the solar disk will minimize pointing error problems.

Table 4.9: Measurement Characteristics for a Total Solar Irradiance Monitor

Observable	Total Irradiance
Precision/Accuracy	0.01%
Repeatability	0.001% per year
Time Cadence	1 min
Duration	Solar Cycle
Completeness	continuous
Field of View	2°

4.10 Coronal Spectroscopy

Spectroscopic measurements in the extended corona are needed to for characterizing the mechanisms that accelerate CMEs (Section 3.1.2.2) and the solar wind (Section 3.1.3.2). These observations are important for SDO but are limited in scope and would require significant resources. Spectroscopic measurements in the corona up to about 2 R_{Sun} can be accomplished with either an internally occulted coronagraph design (see, e.g. LASCO-C1) or a very sensitive “wide angle” EUV spectrograph. However spectroscopic measurements in the extended corona (beyond 1.5 R_{Sun}), require an externally occulted telescope (see, e.g. SOHO/UVCS) due to the rapid decrease with height of coronal emission line intensities. A large aperture, externally occulted coronagraph-spectrometer system would have the proper stray light suppression and sensitivity to allow for the measurement of dozens of faint coronal lines out to heliocentric distances of 10 R_{Sun} . Such an instrument would be capable of characterizing sites of magnetic reconnection and shock formation in CMEs by observing high charge state ions and non-thermal line broadening. It will also measure velocity distributions of H, He, electrons, and heavy ions to determine the power spectrum of resonant MHD waves that may be responsible for heating and acceleration. Helical 3D velocities can be determined

from Doppler shifts and Doppler dimming. Coronal source regions for CME and solar wind plasma can be determined from abundance determinations.

While advanced coronagraph-spectrometers would be desirable, we felt that such instruments could not be accommodated with the present SDO spacecraft resources. However, if an opportunity does arise for flying this type of instruments it would be a valuable complement to the SDO Mission.

Table 4.10: Measurement Characteristics for a UV Coronagraph Spectrometer

Observable	Line Profiles
Precision/Accuracy	Intensity 15 % Width 10% Velocity 5 km/s
Dynamic Range	10^5
Time Cadence	10 min
Spatial Resolution	4"
Field of View	4~30" \times 2000"
Range of View	1.1-10 R_{Sun}
Spectral Resolution	$\lambda/\Delta\lambda \sim 10,000$
Spectral Range	28-140 nm

4.11 Heliometry

Measurements of small changes in the solar radius and limb shape (heliometry) are needed to determine how and where the emergent solar luminosity is gated and stored (Section 3.1.1.2). These measurements are important for SDO but should not require the resources of an additional instrument. The Helioseismic Images from SDO will be important for observing solar

“acoustic” radius fluctuations. The Photometric Images may be obtained in a manner that also allows for heliometry. The magnitude of the radius fluctuation, compared to the irradiance change during a solar cycle contains important information on where and how energy is stored. If W is the ratio of relative radius and irradiance changes, then physical models predict a wide range of values for W . Depending on the mechanism and depth of the interior perturbation estimates of W range from 2×10^{-4} to 7.5×10^{-2} . Given a solar cycle irradiance change of about 10^{-3} , a desirable goal for SDO is to achieve a radius sensitivity of at least 10 milliarcsec on solar rotation time-scales. Such measurements will allow us to clearly discriminate between competing solar cycle luminosity variation models.

5 Potential Instruments and Allocation of Resources

We have examined several generic instruments for inclusion in the SDO payload to estimate the total mass, data rate, power and volume required to accommodate them. These estimates are included in Table 5. Several assumptions have been made in arriving at these estimates. The masses do not include electronics boxes, mounting, radiators, etc. The data rates assume the use of image compression. The range of masses, data rate and volume for the Atmospheric Imaging Array is due to the number of possible telescope tubes.

Table 5. Allocation of Resources

Instrument	Mass (kg)	Data Rate (Mbps)	Power (W)	Volume (cm ³)
HMI	40	25	60	90x40x25
Atmospheric Imaging Array	40-70	20-50	45	100x15x30 100x45x60
EUV SIM	20-30	<1	45	44x48x21
Coronagraph	30	1	35	135x17x17
UV/EUV Spectrometer	40-60	15-30	40	160x60x30
Photometric Mapper	30	5	50	100x30x30
Vector Magnetograph	10+	5	20+	90x40x40
Total	210-270	62-117	295	

6 Mission Concept

This section details the spacecraft, launch vehicle, ground system and data system for SDO. These items have been discussed as being sufficient to support the science as defined in this Science Definition Team report. Future adjustments and variations will undoubtedly occur, as the mission concept matures into the design and development phase.

The science of the Solar Dynamics Observatory optimally will be performed on a spacecraft that allows nearly continuous observations of the Sun and a scientific data rate well in excess of 100 Megabits per second. These two requirements drive the orbit and spacecraft specification and the definition of the SDO Mission. Nearly continuous observations can be obtained from other orbits, such as a low Earth orbit (LEO), but a LEO orbit would require on-board storage of large volumes of scientific data pending

downlink. The large data rate, along with the strict limitations on on-board storage capacity, result in an effective requirement of continuous contact. An inclined geosynchronous (GEO) orbit will allow nearly continuous observation of the Sun, and can downlink data to a single dedicated ground station.

The mission will launch into a geosynchronous transfer orbit (GTO) and then use an apogee kick motor (AKM) or other orbital transfer mechanism to boost the spacecraft into geosynchronous orbit. The spacecraft will be three-axis stabilized and will maintain solar pointing with occasional maneuvers to unload the momentum accumulated in the reaction wheels. Twice a year SDO will undergo “eclipse seasons,” which will last 2-3 weeks, with a maximum Earth eclipse period of approximately 70 minutes. Spacecraft maneuvers, eclipses, and occasional ground system outages will interrupt the scientific observations.

Missions of the Living With a Star program are designed to perform investigations of the long-term variations of the Sun-Earth connected system. The SDO mission will be designed for a 5-year baseline with expendables to last an additional five years of an extended mission.

Table 6.1 illustrates the mass breakdown used in a preliminary definition study for SDO. Compared are the mass estimates for a custom-built spacecraft and a spacecraft from the Rapid Spacecraft Development Office (RSDO) catalog. An instrument module mass of 200 kg, an Apogee Kick Motor (AKM) mass of 668 kg, and the RSDO catalog mass estimates were used in the study calculations. Modifications of a custom-built bus would include a lighter battery, a lighter structural composition of the bus, and adjustments to the propulsion and communication systems.

Table 6.1: SDO Preliminary Study Bus and Payload Mass Breakdown (kg)

	Custom	RSDO
ACS	54	42
Power	60	92
Harness	15	19
RF comm.	35	72 w/ C&DH
C&DH	11	
Propulsion	10	61
Hydrazine	20	20
AKM Stage	10	8
Balance Wt.	10	7
Thermal	60	
Mechanical	34	114 w/ therm
Subtotal	319	434
Instruments	200	200
AKM	668	668
Total	1187	1302

6.1 Orbit Selection

The orbit of the Solar Dynamics Observatory will allow a high science data rate (160 Mbps) and nearly continuous contact via a single dedicated ground station. This ground station can be built and operated at a fraction of the cost of a mission that would rely on existing ground contact networks. The ground track of a geosynchronous orbit with an inclination of 28.5 degrees orbit is shown in Figure 6.1, projected onto 102 degrees Earth longitude.

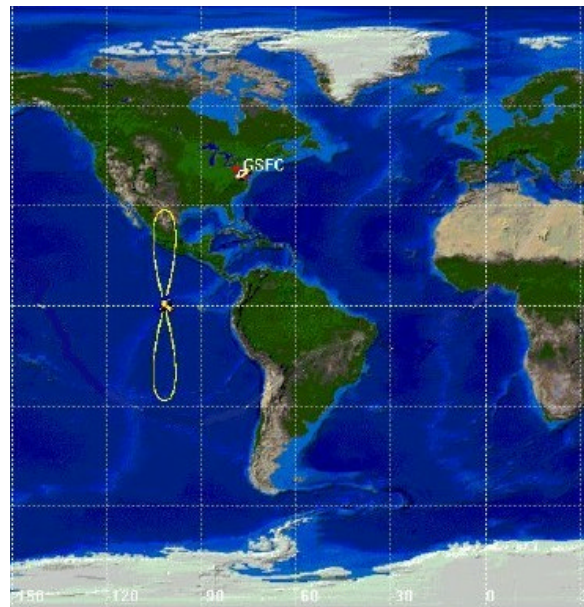

Figure 6.1: Ground track of geosynchronous orbit with an inclination of 28.5 degrees.

The disadvantages of this orbit include launch and orbit acquisition costs (relative to LEO) and eclipse (Earth shadow) seasons twice annually. During these 2-3 week eclipse periods, SDO will experience a daily interruption of solar observations. The maximum duration of these interruptions is 70 minutes, during which solar observations will be interrupted. The spacecraft attitude control system (ACS) and power system must recover from each of these eclipse periods, which may involve a longer duration

of the interruption of the scientific observations. Three lunar shadow events also occur annually, with durations of approximately 30 minutes. The total duration of these interruptions is approximately 45 hours annually. Eclipse and shadow periods are shown in Figure 6.2.

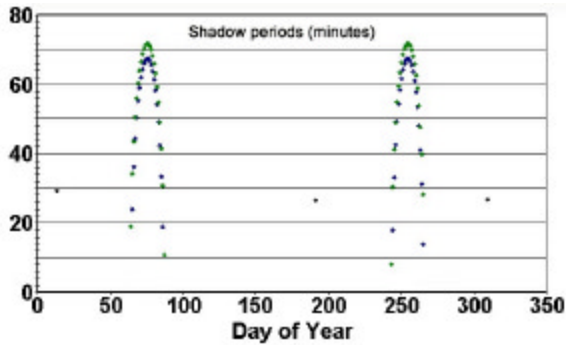

Figure 6.2: Annual periods of Earth and lunar shadow (minutes per day).

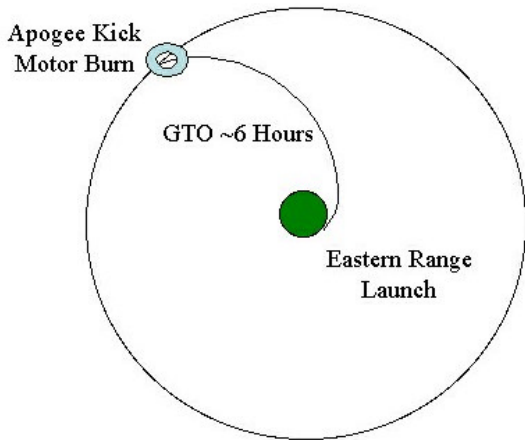

Figure 6.3: Illustration of a launch to geosynchronous transfer orbit (GTO) and orbit circularization with an Apogee Kick Motor.

SDO's orbit can be achieved with a launch into a geosynchronous transfer orbit (GTO), with an apogee kick motor (AKM) to circularize the orbit at geosynchronous altitude (Figure 6.3). The total mass to be lifted to GTO includes the spacecraft and instruments as well as the AKM. Figure 6.4 compares the mass capabilities to GTO of vari-

ous launch vehicles, using an AKM such as the Star-30E and a spacecraft mass of 634 kg. The Delta 2925 meets the launch mass criteria, but other vehicles such as the Delta Lite and the Taurus would require use of a much lighter spacecraft and AKM, or would require the consideration of an alternate orbit profile. During the design of the SDO mission, contingency and mass margins as well as mass and spin balance requirements must be taken into consideration; these items will constrain the total mass able to be accommodated.

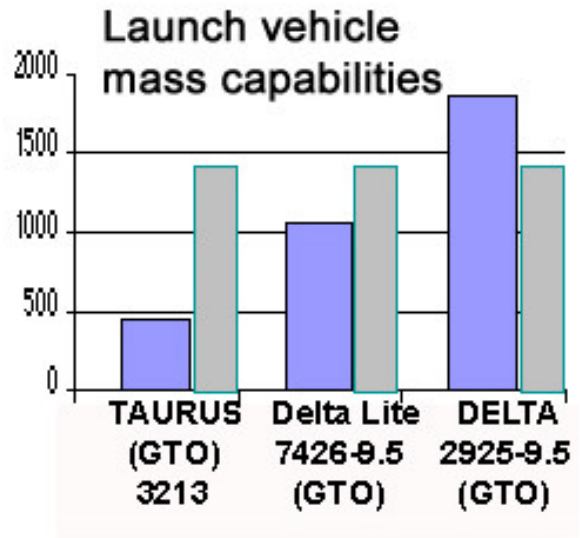

Figure 6.4: Mass margins for various launch vehicles. The total mass of the spacecraft and AKM is shown in gray. The launch vehicle capabilities (in mass to GTO) are shown in blue. A Delta 2925 has a margin of nearly 500 kg.

6.2 Attitude Control System

Most of the requirements of the SDO mission can be met by a geosynchronous spacecraft from the RSDO catalog, with some necessary adjustments. The standard geosynchronous ACS would include a star-tracker, course and fine sun sensors, gyroscopic sensors and reaction wheels. Four reaction wheels in a pyramid configuration will allow efficient unloading of accumu-

lated momentum and will provide redundancy for a long-term mission design. Attitude control system considerations include the adaptation of a geosynchronous spacecraft to maintain a sensitive three-axis stabilized solar pointing. These modifications would include a measurement from a guidescope in the instrument package which will link to the ACS to meet the stability requirements required by the instrument package, and the use of low-jitter reaction wheels (such as the SMEX Lite IRWA) to restrict the jitter introduced to the system.

The spacecraft ACS requirements which were discussed were as follows:

Jitter: The instruments with higher resolution place restrictions on the amount the pointing can vary during the collection of data. The HMI and AIA require that the jitter in both pitch, yaw and roll not vary by more than a fraction of a pixel over the interval of time required to collect the data. Therefore, the image must be stabilized to .25 arcsec (3 sigma) over a few seconds (determined by the image collection time) in pitch and yaw. It is likely that the spacecraft ACS will not be able to satisfy this requirement, and will have a pitch/yaw jitter near 5 arcsec over 45 seconds. The instruments would incorporate image stabilization using data from the guidescope. Because the image stabilization system cannot correct for jitter in the roll axis, the roll jitter must be held to within 50 arcsec (3 sigma) over a period of 45 seconds.

Accuracy/Stability: It is estimated that an image stabilization system cannot function properly at angles greater than 10-15 arcsec; therefore, if the spacecraft introduces 5 arcsec jitter, the greatest deviation from the overall pointing must be within 5-10 arcsec (3 sigma) in pitch and yaw. A coronagraph requires a similar accuracy in pitch and yaw;

based on the field of view and the design of the coronagraph, the Sun must be centered behind the occulting disk to within a desirable tolerance. The accuracy and stability of the roll of the spacecraft is specified in relative terms; the HMI requires a stable viewing angle, though the angle does not necessarily have to be aligned at solar North.

Attitude Knowledge: Because of its restricted field of view, the spectrometer would require a knowledge of a fraction of the instrument resolution. Therefore, the knowledge in pitch and yaw would be set at a fraction of an arc second (which can be provided by the ACS or by the instrument package). The HMI requires a roll knowledge of 30-60 arcsec (3 sigma), corresponding to a fraction of a pixel at the solar limb.

SDO will have several modes of operation including: **Science mode** - 3-axis zero-momentum control, pointing roll axis toward the Sun, run wheels in bias speed, using measurement from guide telescope for pitch and yaw and star tracker measurement for roll; **Calibration mode** - includes possible offsets and maneuvers for instrument calibration; **Safehold mode** - uses CSS and wheel to point solar array normal to the Sun, similar to Sun acquisition; **Delta V mode** - for orbit maintenance; and **Delta H mode** - to unload momentum using propulsion

These operational modes may need to include periods of recovery from Earth shadow periods, and maneuvers to assist in instrument calibration.

6.3 Data and Communication System

Commands to the science instruments will be scheduled for 1 contact per day. The high rate science data downlink, at 160 Mbits/sec,

and the low rate housekeeping data will be continuously maintained between the ground and the spacecraft.

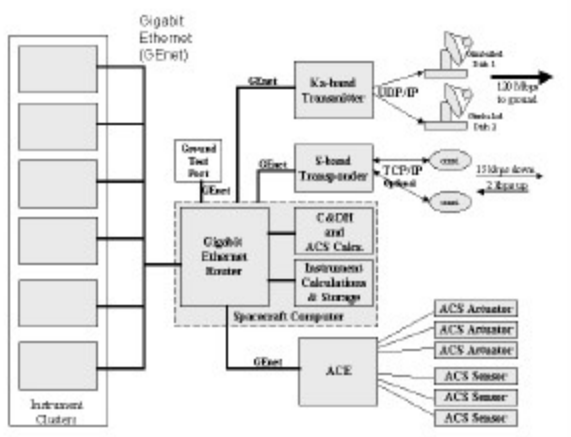

Figure 6.5: SDO CD&H system.

6.4 Spacecraft Power

The instruments were assumed to require a combined power of 250 Watts, with 50 Watts for survival. (The estimates were based on 24% efficient Triple Junction GaAs cells, with 2 spacecraft wings, each with solar array area of 3.2 square meters, including losses from UV and energetic particle radiation, thermal cycling, assembly losses, and losses from SA to battery, battery to load, & SA to load.) The estimates of the spacecraft power requirements are listed in Table 6.2

Table 6.2. Spacecraft bus eclipse power (W)

	Custom	RSDO
ACS	84	53
Power	21	52
RF comm.	100	41
C&DH	35	12
Propulsion	5	12
Thermal	50	91
Harness	23	
Total	295	284

6.5 Instrument Module

An instrument module must accommodate the SDO instruments and provide an acceptable launch environment. The instrument module consists of a mounting structure, instrumentation, cables, heaters and radiators. The mounting structure shall be designed to serve as an optical bench to allow for mounting and alignment of the sensitive SDO instruments. Figure 6.6 shows an illustration of the launch configuration of SDO, including the instrument module, AKM, and solar panels in a 9.5-foot Delta fairing.

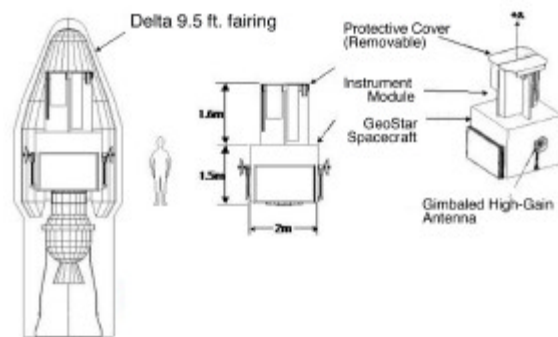

Figure 6.6: SDO instrument module launch configuration

6.6 Ground System

The SDO mission utilizes an inclined geosynchronous orbit to take advantage of a single dedicated ground station. This ground station would ideally be located in a location with minimal effects of rain attenuation. X-band frequencies are becoming less available to missions in the space sciences; it is likely that the primary downlink of SDO data will use Ka- or Ku-band frequencies. For space research 37 GHz is currently allocated, with a possibility of allocation at 21 or 27 GHz. The Ku and Ka frequencies suffer greater rain attenuation than X-band, but the antennae are much smaller and can be

built inexpensively, and backup stations can be considered to meet data completeness requirements.

Data latency (including delivery to final users) requirements may drive ground system considerations; several of the LWS partners may require latency significantly less than an hour. Additionally, the high science data rate indicates that only the health and safety data would be able to be stored on board in the event of a contact interruption. The data gathering architecture will be selected to maximize long continuous streams of valid data. The high data completeness requirement will also be a design driver for the ground system and the downlink margins.

During the nominal mode of spacecraft operation, the ground system can operate as a semi-autonomous system, allowing standard operations to proceed on a 40 hour per week schedule. The geosynchronous orbit and on-board safing systems make the use of a semi-autonomous ground system a low risk and low cost way of meeting the mission requirements.

6.7 Mission and Science Operations

Most of the SDO planned instruments are full-disk instruments and the observations of the mission are not “event-driven,” (e.g. responses to flares or CMEs). There is considerable value in collecting observations as routinely, and under as stable observing conditions and repeatable operation scenarios, as possible. Thus, the nominal science mode of operation can be accomplished with daily command loads similar to those used by the TRACE mission. Instead of near-real-time commanding, daily command loads compiled by the PIs will be sent by the Mission Operations Team.

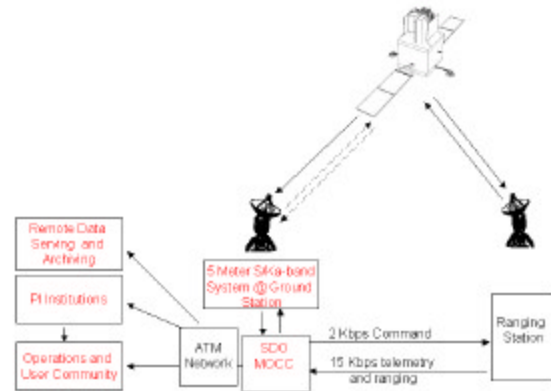

Figure 6.7: SDO Mission Operations and Ground System Network

The Mission Operations Center, Science Operations Center and Ground System could be distributed or centralized. Centralization requires less transport of data over the Internet and greater communication between the mission operations and science teams. However, the cost of data transport at the time of the SDO mission is unknown, and the cost advantage gained from less transport requires further study. Moreover, the cost of temporary storage of SDO data at the ground system site (to compensate for temporary network and distribution failures) is dependent on the future price of bulk storage.

The ground station will be able to strip the science data packets from the downlink stream and send them to the storage sites, either at PI institutions or at a centralized data service. The packets will be assembled into Level Zero data sets and may receive additional processing prior to being made available for distribution.

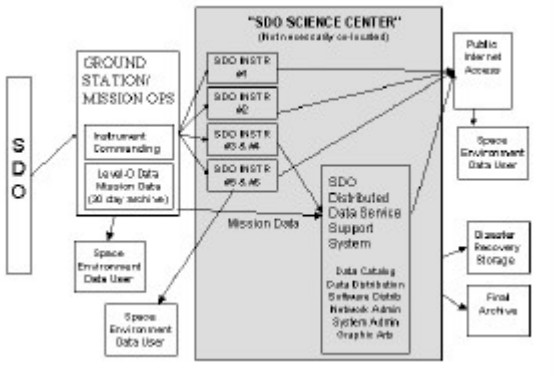

Figure 6.8: SDO Distributed Data System

Data generated by LWS missions are to be free and publicly available for analysis. Proper support of an open data policy requires the provision of the development of software and analysis tools and calibration algorithms by the instrument team. These services will be provided through the Principal Investigations.

7 Concurrent Observations

Several space-based and ground-based instruments will be operational at times during the SDO mission. Observations from some of these instruments [particularly those on other LWS missions] will, at the very least, complement those from the SDO instruments. In some cases (e.g. total solar irradiance) these observations may replace those that otherwise would need to be obtained with SDO. The following sub-sections describe the instruments as they were specified at the time of this report. Future changes in these specifications may influence the final choices for SDO instruments. Table 7 lists the facilities along with their anticipated dates of operation and key measurements.

Table 7: Concurrent Observations

Facility	Measurements	Date
STEREO	Atmospheric Images Coronal Images	2006-2011
Solar-B	Atmospheric Images Magnetograms UV/EUV Spectra	2005-
Solar Probe	Atmospheric Images Coronal Images Magnetograms	2010-2015
SORCE	Total Irradiance Spectral Irradiance	2002-2007
GOES/NPOESS	Total Irradiance Spectral Irradiance	2010-
SOLIS	Magnetograms Spectra	2001-2025
ATST	Magnetograms	N/A
Solar Sentinels	Atmospheric Images Helioseismic Images	N/A
Solar Orbiter	Atmospheric Images Coronal Images Magnetograms UV/EUV Spectra	2009-
FASR	Coronal Magnetograms	N/A

7.1 STEREO

STEREO (Solar-TERrestrial RELations Observatory) will provide new perspectives on the structure of the solar corona and CMEs by moving away from our customary Earth-bound vantage point and by using two spacecraft to provide information on three-dimensional structure. Both spacecraft carry a suite of instruments including: two coronagraphs (covering the range 1.25 - 4 R_{Sun} , and 2-15 R_{Sun}), an extreme ultraviolet imager (full-disk, 1 arcsec pixels), a heliospheric imager (an externally occulted coronagraph that can image the heliosphere from 12 R_{Sun} to beyond Earth's orbit), an interplanetary radio burst tracker, *in situ* particle and field detectors, and a plasma composition experiment.

This mission is designed: to further our understanding of the origins and consequences of CMEs, to determine the processes that control CME evolution in the heliosphere, to discover the mechanisms and sites of solar energetic particle acceleration, to determine the 3D structure and dynamics of coronal and interplanetary plasmas and magnetic fields, and to probe the solar dynamo through its effects on the corona and the heliosphere.

The STEREO Mission spacecraft are expected to be launched in December 2005. The two spacecraft will slowly drift apart in ecliptic longitude with a total separation of 45° after the first year and 90° after the second year. The mission is expected to last two years at minimum and, more likely, five years.

STEREO will overlap with SDO and provide coronagraphic images like those needed for SDO. STEREO's lifetime, however, is shorter than SDO's and during parts of the STEREO mission the STEREO instruments will be viewing solar regions far removed from the SDO observations. The STEREO coronagraphs will complement the measurements made from SDO but cannot be used to replace them.

7.2 Solar-B

Solar-B is a Japanese mission proposed as a follow-on to the highly successful Japan/US/UK *Yohkoh* (Solar-A) collaboration. The mission consists of a coordinated set of optical, EUV and X-ray instruments that will investigate the interaction between the Sun's magnetic field and its corona. The result will be an improved understanding of the mechanisms that give rise to solar magnetic variability and how this variability

modulates the total solar output and creates the driving force behind space weather.

The spacecraft will accommodate three major instruments: a large solar optical telescope (SOT), an X-ray telescope (XRT), and an EUV Imaging Spectrograph (EIS). All three major instruments will give extremely high resolution observations of a field of view on the Sun that is restricted to an active region spatial scale. The SOT includes focal plane instruments that will provide longitudinal magnetograms with 1-5G sensitivity and vector magnetograms with 30-50G sensitivity to transverse fields. The XRT provides atmospheric images at wavelengths from 2 to 6 nm. The EIS provides UV/EUV spectra with a resolving power of about 10,000 over wavelength ranges from 17-21 nm and 25-29 nm (covering temperatures from 10^5 to 10^7 K but with only one strong emission line below 10^6 K).

The Solar-B spacecraft is scheduled for launch in the fall of 2005. It will be placed in a polar, sun-synchronous orbit about the Earth. This will keep the instruments in continuous sunlight, with no day/night cycling for nine months each year. Solar-B will address some of the same problems that SDO will address but with higher spatial resolution and a smaller field of view. The combination of vector magnetograms, atmospheric images, and UV/EUV spectra should provide the measurements needed to answer many of the outstanding questions concerning the initiation of flares and CMEs.

7.3 Solar Probe

The Solar Probe mission is an unprecedented exploration of the inner heliosphere, which will achieve unique science by flying over the pole of the Sun and as close to the Sun's surface, through the solar corona, as is

technologically feasible today. It will first travel to Jupiter for a gravity assist, leave the ecliptic plane, fly over the Sun's poles to within 8 solar radii, and reach perihelion over the equator at 4 solar radii. A unique aspect of the Solar probe orbit is that the trajectory is orthogonal to the Sun-Earth line during perihelion passage so that there is continuous radio contact throughout the flyby. Two perihelion passes are planned, the first near the 2010 solar maximum and the second near the 2015 solar minimum. This orbit ensures that the mission will probe both the high speed solar wind streams and the equatorial low-speed streams.

The results from SOHO and Ulysses have focused our understanding of the solar corona to the point where *in situ* measurements are now necessary for further progress. Both imaging and *in situ* measurements will provide the first three-dimensional view of the corona, high spatial and temporal resolution measurements of the plasma and magnetic fields, as well as helioseisology and magnetic field observations of the solar pole.

The Solar Probe Nadir-Viewing Imagers will provide the only full view of the Sun's Poles, imaging both the North and South Pole within one day. The Solar Probe Magnetograph/Helioseismograph will provide out-of-the-ecliptic observations of the polar magnetic field and polar sub-surface flow patterns essential to answering fundamental questions related to the solar dynamo and the origins of the solar cycle.

The observations of the solar corona and solar wind that Solar Probe will provide are critical to understanding fundamental processes that can be obtained in no other way, and will provide a set of measurements that complement, but are distinct from, the SDO observations. Finally, the Solar Probe obser-

vations of the polar magnetic field and polar sub-surface flow patterns are essential to answering fundamental questions related to the solar dynamo and the origins of the solar cycle, which are central to the SDO primary scientific objectives, but which cannot be obtained with the SDO spacecraft.

7.4 SORCE

SORCE (Solar Radiation and Climate Experiment) is a program within NASA's Office of Earth Science (OES) for measuring solar irradiance. The solar-pointed SORCE spacecraft carries five instruments to measure both total and spectral solar irradiances. These are the Total Irradiance Monitor (TIM), Spectral Irradiance Monitor (SIM), two identical Solar Stellar Irradiance Comparison Experiments (SOLSTICE) and the X-ray Photometer System (XPS).

The TIM measures total solar irradiance using electrical substitution radiometers. The observations have an uncertainty goal of 0.01% and a long-term repeatability of 0.001% per year.

The SIM measures solar UV, visible and IR spectral irradiance from 200 nm to 2000 nm with spectral resolution ranging from a few nm at UV wavelengths to tens of nm at IR wavelengths. It uses a prism for wavelength dispersion and a bolometer and diodes for signal detection. The SIM spectral irradiances have uncertainties of 0.03% and long-term repeatabilities of 0.01% per year.

The two SOLSTICE instruments measure the solar UV spectral irradiance from 120 to 300 nm with spectral resolution of about 0.1 nm, using grating spectrometers that have the capability also to observe bright blue stars for calibration tracking. The SOLSTICE UV spectral irradiance uncertainties

are in the range 3% to 6% and repeatabilities are 0.5%.

The XPS is a bank of broadband X-ray photometers in the range 1 – 31 nm with spectral bands 5 to 10 nm, uncertainty of 12% and repeatability of 3% per year.

SORCE will be launched in mid 2002, with expected mission duration of 5 years. It will overlap with ACRIMSAT, which has provided total solar irradiance data since 2000, thereby extending the continuous record of total solar irradiance that commenced in late 1978. NASA OES plans to continue the solar irradiance measurements with a follow-on solar irradiance mission in the time frame of 2006-2011 that measures total solar irradiance (e.g., TIM) and spectral irradiance from 200 to 2000 nm (e.g., SIM).

7.5 GOES/NPOESS

GOES (Geosynchronous Operational Environmental Satellites) and NPOESS (National Polar-orbiting Operational Environmental Satellite System) are satellite systems deployed by NOAA to monitor the environment.

Solar irradiance will be monitored by NPOESS. Measurements of total solar irradiance and of the solar spectral irradiance in the wavelength range from 200 to 2000 nm with accuracies and precisions similar to those of the TIM and SIM instruments on SORCE are specified. The solar irradiance measurements are designated for flight on one of the three NPOESS spacecraft. Since the priority for the solar measurements is relatively low among other NPOESS measurements, failure of the spacecraft would not trigger an immediate replacement of the solar instruments. This means that gaps may occur in the total solar irradiance measured by NPO-

ESS, expected to commence around 2010, depending on existing resources.

Measurements of solar EUV radiation in five broad bands in the range 10 to 130 nm are planned to be made from future GOES platforms commencing in late 2002, depending on the health and status of existing GOES spacecraft. The EUV broadband fluxes are recorded every 10 seconds, with an uncertainty of 10% and a repeatability of 5% over 7 years. The instrument uses diffraction gratings to disperse the light, thin-film filters to further remove unwanted wavelengths, silicon diode detectors to collect the light and tantalum shielding to eliminate effects from radiation. Two GOES spacecraft are planned to be operational at any one time providing redundancy and cross-calibration for the EUV sensor. With the launch of each new GOES EUV Sensor every (2-5 years), a new calibration will be applied to the data set.

In addition to these major resources, at least two European programs are planning to measure solar irradiance during the next decade. Three solar instruments (ACES, SOVIM and SOLSPEC) will measure the total solar irradiance and the solar spectrum from the EUV to the IR. The solar package is presently scheduled as part of the *Columbus* module of the International Space Station, to be launched during 2004-2005 with a priority of solar minimum observations. PICARD, a small spacecraft carrying instruments to measure the total solar irradiance and solar diameter, is under development in France, for launch by CNES around 2006 with a 2-3 year mission duration.

These measurements may facilitate the calibration of the SDO EUV Spectral Irradiance measurements but will not have the spectral resolution or coverage to replace them.

7.6 SOLIS

SOLIS (Synoptic Optical Long-term Investigations of the Sun) is a ground-based project of NSO to provide regular observations of the Sun for at least 25 years. It will replace many of NSO's current synoptic facilities. The primary science objectives are to increase understanding of solar activity and its effects on earth by means of observations of the Sun's full vector magnetic field and the dynamics and evolution of solar changes related to the magnetic field. Aside from basic research on the solar activity cycle, the observations will also be used as inputs to test models that are alleged to be able to forecast activity.

The first SOLIS facility is nearing completion and the recent NAS/NRC report "Astronomy and Astrophysics in the New Millennium" recommends building two additional systems to be located at longitudes different from the US. This would increase the average 24-hour duty cycle from about 30% to about 80%. The US system includes three instruments: a vector spectromagnetograph (VSM), a full-disk monochromatic imager, and an integrated sunlight spectrometer for sun-as-a-star spectroscopy.

The VSM is the most unique instrument and would be the common network instrument. The VSM is a 50-cm telescope and a high-resolution spectrograph. It can provide full-disk vector magnetograms in about 15 minutes with a polarimetric noise level of about 3×10^{-4} using one arcsecond pixels. It will also provide high-sensitivity photospheric and chromospheric line-of-sight component magnetograms as well as He I dynamics images.

The monochromatic imager provides intensity and Doppler images in a number of solar spectrum lines using one arcsecond pix-

els. Quick-look SOLIS data will be available on the Web within 30 minutes and more accurately reduced data within 24 hours. Special campaigns and user-proposed programs can be interleaved with the regular synoptic observations. The synoptic data will be openly available.

SOLIS and SDO will complement each other in a number of ways. Lightweight space magnetographs will be filter based and it will be very useful to compare results from such an instrument with the higher spectral resolution SOLIS measurements to seek out systematic errors in both types of observations. Similarly, the higher spatial resolution space observations will permit a study of how ground-based observations are degraded by terrestrial seeing. In case a vector magnetograph is not flown on SDO, the SOLIS vector observations will provide an obvious enhancement. The same holds true for the chromospheric magnetograms. SOLIS will provide regular monochromatic measurements of intensity and dynamics in the cool solar atmosphere that will be valuable for use with the SDO high temperature measurements. Perhaps the best complementarity would be one that we cannot predict, namely, some SDO discovery that stimulates follow-up observations with SOLIS, or vice versa.

7.7 ATST

ATST (Advanced Technology Solar Telescope) is a proposed ground-based telescope facility designed for high-resolution studies of the Sun. The proposal is for a 4-meter telescope operating in the visible and infrared (0.3 to 35 microns) with very high resolution (0.1 arcsec or better) and a large photon flux for sensitive polarimetry. The facility will have the spatial resolution and sensitivity to study the ubiquitous weak magnetic field elements in the photosphere and

measure magnetic fields in the corona. It will have the capability to examine waves in magnetic flux tubes to test models of chromospheric and coronal heating. It will have a 5 arcmin field of view that will allow studies of active region evolution and the initiation of flares and CMEs.

ATST will address some of the same problems that SDO will address (e.g. small-scale magnetic elements) but with higher spatial resolution, smaller field of view, and less complete coverage. The proposal suggests that operations begin in about 2008.

7.8 Solar Sentinels

The Solar Sentinels will consist of a fleet of spacecraft distributed throughout the heliosphere. They will help to improve the accuracy of models of CMEs and other solar wind transients. They will resolve geoeffective solar wind structures and map them back to solar features. They will search for the locations and mechanisms of energetic particle acceleration, and provide tomographic images of the Sun. When fully deployed, the Sentinels will increase the lead-time and accuracy of geospace forecasts.

The Inner Heliospheric Sentinels will make *in situ* observations of the heliospheric vector magnetic field, the solar wind plasma properties, and the spectrum of high-energy particles. They will make remote measurements of the propagation of interplanetary shocks by tracking radio bursts. A Farside Sentinel will also provide EUV images of the solar corona along with photospheric magnetograms. Radio occultations will be employed along with these images and those from SDO to identify the birthplace of transients. Helioseismic measurements will be made in conjunction with those from SDO

to follow the development of structures within the Sun.

The fleet will consist of four Inner Heliospheric Sentinels in heliocentric orbits ranging between 0.5 and 0.95 AU, a FarSide Sentinel in a 1 AU orbit opposite Earth, on the far side of the Sun, and a single L1 Sentinel to provide solar wind input information to the geospace components. These elements will work together to track solar disturbances as they evolve and transit the inner heliosphere. The inner heliospheric sentinels are spinning satellites. The FarSide Sentinel is three-axis stabilized.

Solar Sentinels will supplement SDO observations to provide continuous and whole surface imaging of the photosphere and solar corona, hence allow the study of evolution of solar active regions. The observations complement those from SDO but with little or no redundancy.

7.9 Solar Orbiter

The Solar Orbiter was selected by ESA at the end of 2000 as a “flexi”- mission, for launch in the 2008-2013 time frame. The key mission objectives of the Solar Orbiter are: (a) to study the Sun from close-up (45 solar radii, or 0.21 AU), and (b) to provide images of the Sun's polar regions from heliographic latitudes as high as 22 degrees during the nominal mission, and over 30 degrees during the extended mission.

Solar Orbiter's unique heliosynchronous, near-Sun trajectory will allow, in conjunction with concurrent high-resolution remote sensing observations, *in situ* investigations of the energetic particle environment in close proximity to different source regions, such as active regions, flare locations, CMEs and associated shocks. Solar Orbiter's

unique high-latitude trajectory will allow it to determine the longitudinal extent of CMEs and provide, in conjunction with SDO and ground-based observatories, full coverage of the entire Sun over 360° in longitude.

The potential payload includes two instrument packages: the Heliospheric *in situ* instrument package and the Solar Remote sensing instrument package. The Heliospheric *in situ* instruments include: a solar wind analyzer, radio and plasma wave analyzers, a magnetometer, energetic particle detectors, an interplanetary dust detector, a neutral particle detector, and a solar neutron detector. The Solar remote sensing instruments include: an EUV full-Sun and high resolution imager, a high-resolution EUV spectrometer, a high-resolution visible-light telescope and magnetograph, an EUV and visible-light coronagraph, and a radiometer.

We hope that the interested parties within ESA will do everything possible to ensure a launch in a timely manner, i.e. in 2009 or soon after. From recent solar and heliospheric physics missions, e.g. SOHO, *Yohkoh*, TRACE, and *Ulysses*, we have learned that by far the best scientific return from missions is through efficient coordination. A launch of Solar Orbiter in 2009, or soon after, would provide a significant overlap with SDO. The combination of Earth-orbit high-resolution observations from SDO with the close-encounter and polar observations from Solar Orbiter would allow an invaluable, thorough analysis of many aspects of solar activity and its influence on the Earth.

7.10 FASR

FASR (Frequency Agile Solar Radiotelescope) will provide radio observations of coronal magnetic fields that complement optical/IR measurements of photospheric

and chromospheric fields, and in this regard promises to be an important supporting instrument for SDO studies of the magnetic field in the corona. FASR has been rated highly by the NRC panel on the future of ground-based solar astronomy, and recommended as a moderate-sized initiative by the decadal NRC Astronomy and Astrophysics Survey Committee. The telescope will be a solar-dedicated instrument providing excellent images of the full Sun with arcsecond spatial resolution at a wide range of frequencies nearly simultaneously, with both targeted research and synoptic capabilities.

Radio observations are able to measure magnetic fields due to the gyroresonance effect: electrons spiraling in the coronal magnetic fields provide opacity at radio wavelengths at low harmonics of the electron gyrofrequency, $2.8 \times 10^{-3} B$ GHz where B is measured in Gauss. A given observing frequency and sense of circular polarization is sensitive to a single value of magnetic field strength; by changing frequencies FASR will be sensitive to magnetic fields in the range 100 - 2000 G. Surfaces of constant magnetic field strength show up in radio maps at the appropriate frequency as bright regions: they have coronal brightness temperatures because gyroresonance opacity makes them optically thick, whereas the surrounding atmosphere with lower magnetic field strength is optically thin and has much lower brightness temperature. The dependence of opacity on viewing angle introduces some complications but the theory is well understood, and radio data have proven to be excellent diagnostics for testing extrapolations of photospheric fields into the corona.

8 Acknowledgements

The Science Definition Team would like to acknowledge the following people for their

assistance in the production of this report: John Leon, Paul Caruso, Sahag Dardarian and Ron Miller from the GSFC Project team for their support during the discussions of mission requirements; Art Poland, Dick Fisher, Karel Schrijver and the LWS Science Architecture Team for LWS program science support; Members of the SDO Mission Science Preformulation Team: Leon Golub, Russ Howard, Steve Kahler, Dana Longcope and Vic Pizzo; Military Space Weather advisers during preformulation: Lt. Col. Michael Bonnadonna, Maj. Peter Engelmann, Capt. Riley D. Jay, Maj. Phyllis Kampmeyer and Lt. Col. Erwin Williams; Joe Gurman and Terry Kucera at GSFC for mission development; Jennifer Rumburg for information systems; Scientists who assisted in the instrument study and discussions: Rock Bush, Darrell Judge, Don McMullin, Jesper Schou, Jake Wolfson and Tom Woods.