

These slides: <http://sporadic.stanford.edu/bump/Montreal.pdf>

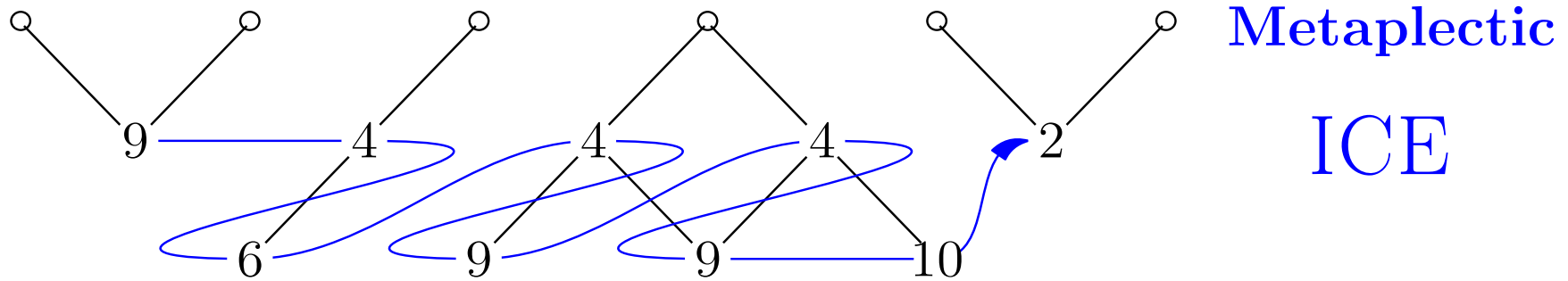

and the

Combinatorics
of
Whittaker
Functions

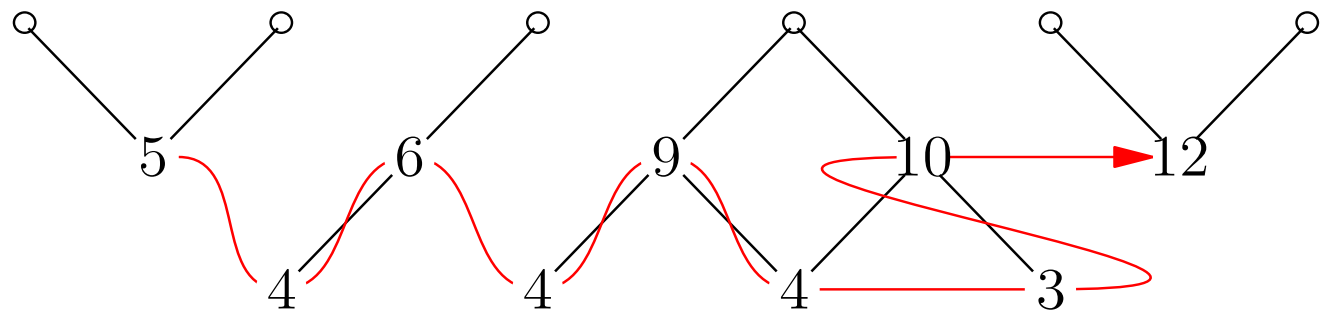

Work of Brubaker, Bump, Friedberg, Chinta, Hoffstein and Gunnells.

Supported in part by NSF Grant 1001079.

References

I will report mainly on two works about **spherical** Whittaker functions on metaplectic groups.

- **Weyl Group Multiple Dirichlet Series: Type A Combinatorial Theory** by Brubaker, Bump and Friedberg (Annals of Mathematics Studies, 2011).
- **Metaplectic Ice** by Brubaker, Bump, Friedberg, Chinta and Gunnells.

A complete picture for just the spherical Whittaker function would also include the very different approach by Chinta and Gunnells, work of Peter McNamara, Chinta and Offen.

Recent work on **Iwahori** Whittaker functions includes recent work of Brubaker, Bump and Licata ($n = 1$) and of Chinta, Gunnells and Puskás ($n > 1$). This too is combinatorially interesting, much richer than the spherical case. The main new feature is the appearance of **Demazure operators** which, in the metaplectic case are related to the Kazhdan-Patterson-Chinta-Gunnells action of the Weyl group. We will not report on this today.

The Whittaker Function as a Combinatorial Object

Let F be a nonarchimedean local field, \mathfrak{o} , \mathfrak{p} the integers and its maximal ideal, p a fixed generator of \mathfrak{p} , and $q = |\mathfrak{o}/\mathfrak{p}|$.

Spherical Whittaker functions on a split reductive p -adic group $G(F)$ are in a sense well-understood. Let \hat{G} be the Langlands dual group. Then G and \hat{G} contain maximal tori T and \hat{T} that are in duality. Let $\Lambda = X^*(\hat{T})$, the weight lattice in \hat{G} . If $\lambda \in \Lambda$ is a **dominant weight** then λ indexes the following data:

- An element t_λ of $T(F)$ determined modulo $T(\mathfrak{o})$,
- A finite dimensional representation of $\hat{G}(\mathbb{C})$ with character χ_λ , highest weight λ .

If $\mathbf{z} \in \hat{T}(\mathbb{C})$, then \mathbf{z} indexes:

- A representation of $G(F)$ and its **Whittaker function**.

The **Casselman-Shalika formula** asserts

$$W(t_\lambda) = \prod_{\alpha \in \Delta^+} (1 - q^{-1} \mathbf{z}^{-\alpha}) \chi_\lambda(\mathbf{z}).$$

(The usual normalization would have $1 - q^{-1} \mathbf{z}^\alpha$ but this is more convenient for us.)

If F contains the n -th roots of unity we may consider instead a Whittaker function on the n -fold metaplectic cover $\tilde{G}(F)$. Then $W(t_\lambda)$ is a **very interesting combinatorial object**.

The Weyl Character Formula

Let $\hat{G}(\mathbb{C})$ be a complex reductive Lie group, realized as an affine algebraic group. Let \hat{T} be a maximal split torus, and $\mathbf{z} \in \hat{T}(\mathbb{C})$. Let $P = X^*(\hat{T})$ be the weight lattice. Let λ be a dominant weight and let χ_λ be the irreducible character of $\hat{G}(\mathbb{C})$ with highest weight λ . By the **Weyl character formula**

$$\prod_{\alpha \in \Delta} (1 - \mathbf{z}^{-\alpha}) \chi_\lambda(\mathbf{z}) = \sum_{w \in W} (-1)^{l(w)} \mathbf{z}^{w(\lambda + \rho) - \rho} \quad \left(\rho = \frac{1}{2} \sum_{\alpha \in \Delta^+} \alpha \right)$$

The Casselman-Shalika Formula ($n = 1$ case).

The **Casselman-Shalika formula** again:

$$W(t_\lambda) = \begin{cases} \prod_{\alpha \in \Delta} (1 - q^{-1} \mathbf{z}^{-\alpha}) \chi_\lambda(\mathbf{z}) & \text{if } \lambda \text{ is dominant,} \\ 0 & \text{otherwise.} \end{cases}$$

Compare this with the Weyl character formula. The product $\prod_{\alpha \in \Delta} (1 - q^{-1} \mathbf{z}^{-\alpha})$ is a deformation of the **Weyl denominator**

$$\prod_{\alpha \in \Delta} (1 - \mathbf{z}^{-\alpha}) = \sum_{w \in W} (-1)^{l(w)} \mathbf{z}^{w(\rho) - \rho}.$$

The CS formula is a deformation of the Weyl character formula.

Tokuyama's deformation of the WCF

The Weyl character formula has a deformation ([Tokuyama, 1988](#)) that exactly matches the Casselman-Shalika formula. It produces, with t a parameter

$$\prod_{\alpha \in \Delta^+} (1 - tz^{-\alpha}) \chi_{\lambda}(z).$$

Tokuyama expressed this as a sum over strict Gelfand-Tsetlin patterns with shape $\lambda + \rho$. There are different ways of expressing his result.

- As a sum over the Kashiwara crystal $\mathcal{B}_{\lambda + \rho}$.
- As the partition function of an (ice type) solvable lattice model.

Both versions generalize to a formula for metaplectic Whittaker functions.

Gauss sums

Let \mathfrak{o} be the ring of integers in F , \mathfrak{p} its maximal ideal, so $q = |\mathfrak{o}/\mathfrak{p}|$. The **Gauss sum**

$$g(m, c) = \sum_{d \bmod c} \left(\frac{d}{c}\right)_n \psi\left(\frac{dm}{c}\right)$$

where $\left(\frac{d}{c}\right)_n$ is the n -th power residue symbol and $\psi: \mathfrak{o}/\mathfrak{p} \rightarrow \mathbb{C}$ is a fixed nontrivial additive character. If p is a fixed generator of \mathfrak{p} :

$$g(a) = q^{-a} g(p^{a-1}, p^a), \quad h(a) = q^{-a} g(p^a, p^a).$$

Properties

If $n > 2$, the Gauss sums are mysterious but the following properties are enough for us.

Periodic: $g(a+n) = g(a), \quad h(a+n) = h(a)$

If $n \nmid a$: $h(a) = 0, \quad |g(a)| = q^{-1/2}.$ If $n|a+b$ then $g(a)g(b) = q^{-1}$

$$g(a+b)h(a)h(b) = h(a+b)g(a)g(b) + h(a+b)g(a+b).$$

The case $n = 1$

If $n = 1$, $g(a) = -q^{-1}, \quad h(a) = 1 - q^{-1}$

Crystals (Kashiwara)

The Kashiwara crystal \mathcal{B}_λ in type A_r is a directed graph with labeled edges and vertices semistandard Young tableaux (SSYT) of shape λ . Here $\lambda \in \Lambda$ is a dominant weight.

If $v \xrightarrow{i} w$ is an edge we write $w = f_i v$ or $v = e_i w$. In this case $\text{wt}(w) = \text{wt}(v) - \alpha_i$ where α_i is the i -th simple root. There is a unique **highest weight vector** v_λ with $\text{wt}(v_\lambda) = \lambda$.

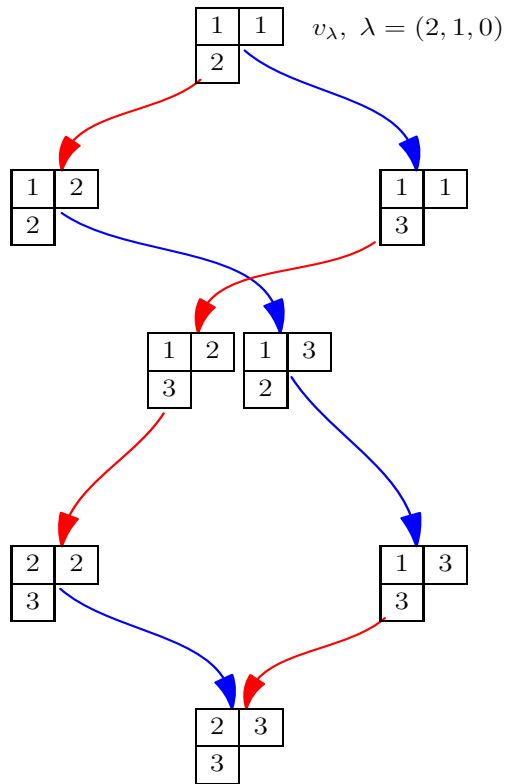

We will use this color scheme for A_2 crystals:

$$v \xrightarrow{\text{red}} w \quad \text{means} \quad v \xrightarrow{1} w$$

$$v \xrightarrow{\text{blue}} w \quad \text{means} \quad v \xrightarrow{2} w$$

There is a weight function $\text{wt}: \mathcal{B}_\lambda \rightarrow \Lambda$ and $\sum z^{\text{wt}(v)} = \chi_\lambda(v)$. Thus \mathcal{B}_λ is a combinatorial analog of the irreducible representation π_λ of \hat{G} with highest weight λ .

String Patterns (Berenstein, Zelevinsky, Littelmann)

For example if $n = 2$ and $\lambda = (2, 1, 0)$. Traditionally the vertices are Semistandard Young Tableaux (SSYT) of shape λ but they can also be parametrized by Gelfand-Tsetlin Patterns (GTP) with top row λ or string patterns (BZL). The BZL patterns are important for us so we review them. We fix a special word $s_{i_1}s_{i_2}s_{i_3}\cdots s_N$ representing the long Weyl group element, $N = \frac{1}{2}r(r+1)$. We either $(i_1, i_2, \dots, i_N) = \Omega_\Gamma$ or Ω_Δ ,

$$\Omega_\Gamma = (1, 2, 1, 3, 2, 1, 4, 3, 2, 1, \dots), \quad \Omega_\Delta = (r, r-1, r, r-2, r-1, r-2, \dots).$$

Beginning at $v \in \mathcal{B}_\lambda$, **we walk to the highest weight vector v_λ** using the raising operators the directions e_{i_1}, e_{i_2}, \dots . That is, let b_1 be the largest integer such that $e_{i_1}^{b_1}v \neq 0$. Then let e_{i_2} be the largest integer such that $e_{i_2}^{b_2}e_{i_1}^{b_1}v \neq 0$. Finally $e_{i_N}^{b_N}\cdots e_{i_1}^{b_1}v = v_\lambda$. We put the distances into an array:

$$\text{BZL}_\Gamma(v) = \begin{pmatrix} b_N & \cdots & & & b_{N-r+1} \\ \vdots & & & \ddots & \\ b_6 & b_5 & b_4 & & \\ b_3 & b_2 & & & \\ b_1 & & & & \end{pmatrix} \quad (\text{or } \text{BZL}_\Delta(v)).$$

Example

For example, consider the marked vertex, which is actually the tableau $v = \begin{array}{|c|c|c|c|c|} \hline 1 & 1 & 2 & 3 & 3 \\ \hline 2 & 2 & & & \\ \hline \end{array}$.

(We have labeled the vertices of this crystal, \mathcal{B}_λ with $\lambda = (5, 2, 0)$ by their BZL patterns.)

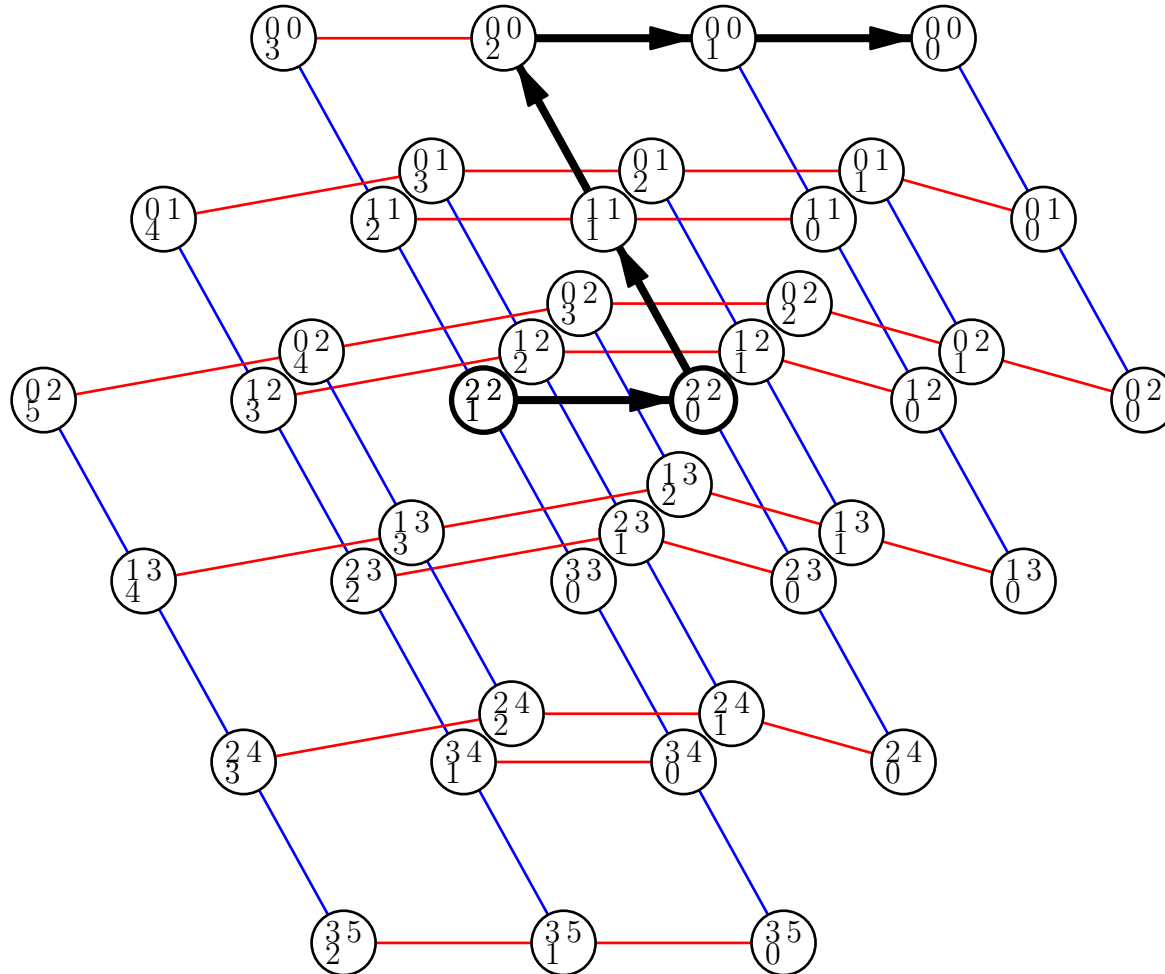

Then b_1, b_2, b_3 are the lengths of the three segments of the path from v to v_λ , so

$$\begin{pmatrix} b_3 & b_2 \\ b_1 & \end{pmatrix} = \begin{pmatrix} 2 & 2 \\ 1 & \end{pmatrix}.$$

Actually we will **decorate** $\text{BZL}(v)$ by boxing or circling certain entries. In this case the decorated pattern is $\begin{pmatrix} 2 & \textcircled{2} \\ \boxed{1} & \end{pmatrix}$. We will explain the boxing and circling rules below.

Circling

Littelmann proved that if

$$\text{BZL}(v) = \begin{pmatrix} \vdots & \vdots & \ddots \\ b_6 & b_5 & b_4 \\ b_3 & b_2 \\ b_1 \end{pmatrix}$$

the entries in each row are increasing. Thus if a row is

$$b_l \cdots b_{k+1} b_k$$

we have $b_k \leq b_{k+1} \leq \cdots \leq b_l = 0$. If any of these inequalities is not strict, that is if $b_i = b_{i+1}$ or (when $i=l$) if $b_i=0$ then we circle b_i .

Boxing

Let $v_k = e_{i_{k-1}}^{b_{k-1}} \cdots e_{i_1}^{b_1} v$. If $f_{i_k} v_k$ is nil then we box b_k . Concretely this means that the sequence $v_k, e_{i_k} v_k, e_{i_k}^2 v_k, \dots, e_{i_k}^{b_k} v_k$ is an **entire root string** within the crystal.

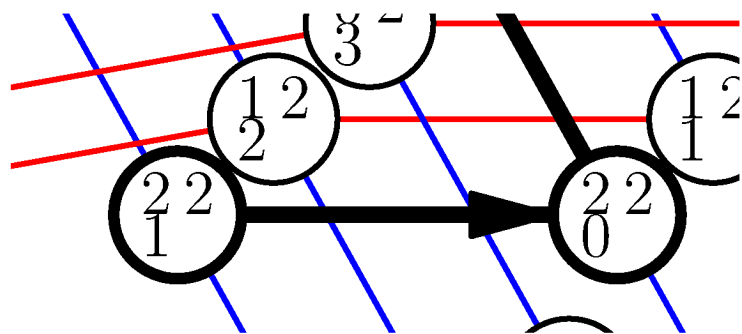

Hence in the example $v_1 = v$. We box $b_1 = 1$.

Also we circle b_2 since $b_2 = b_3$:

$$\text{BZL}(v) = \begin{pmatrix} 2 & \textcircled{2} \\ \boxed{1} \end{pmatrix}$$

The Meaning of Circling and Boxing

Kashiwara defined an infinite crystal \mathcal{B}_∞ . It has a unique highest weight vector with weight 0. By tensoring it with a crystal \mathcal{T}_λ having a unique element of weight λ , we may arrange that the highest weight is λ .

Using the string (BZL) patterns, Littelmann showed (in Type A) that \mathcal{B}_∞ may be identified with the cone of patterns:

$$\left(\begin{array}{cccc} b_N & \cdots & & b_{N-r+1} \\ \vdots & & \ddots & \\ b_6 & b_5 & b_4 & \\ b_3 & b_2 & & \\ b_1 & & & \end{array} \right), \quad \begin{array}{cccc} 0 & b_N & \cdots & b_{N-r+1} \\ \vdots & & & \\ 0 & b_6 & b_5 & b_4 \\ 0 & b_3 & b_2 & \\ 0 & b_1 & & \end{array} \quad N = \frac{1}{2}r(r+1) = |\Delta^+|$$

Now we may recognize the boundary as consisting of the facets of this cone determined by the strict equalities $b_1 = 0$, $b_2 = b_3$, $b_3 = 0$, etc.

We think of \mathcal{B}_∞ and any subcrystal as an integer polytope.

\mathcal{B}_∞ is the crystal of $U(\mathfrak{n}_+)$ where \mathfrak{n}_+ is the maximal nilpotent subalgebra of $\mathfrak{sl}(r+1)$.

Similarly there is a crystal (not in Category \mathcal{O}) $\mathcal{B}_{-\infty}$ of $U(\mathfrak{n}_-)$ with 0 as its lowest weight.

Two embeddings

Embed $\mathcal{B}_{\lambda+\rho}$ (green) into $\mathcal{B}_{\infty} \otimes \mathcal{T}_{\lambda+\rho}$ (extending downwards)

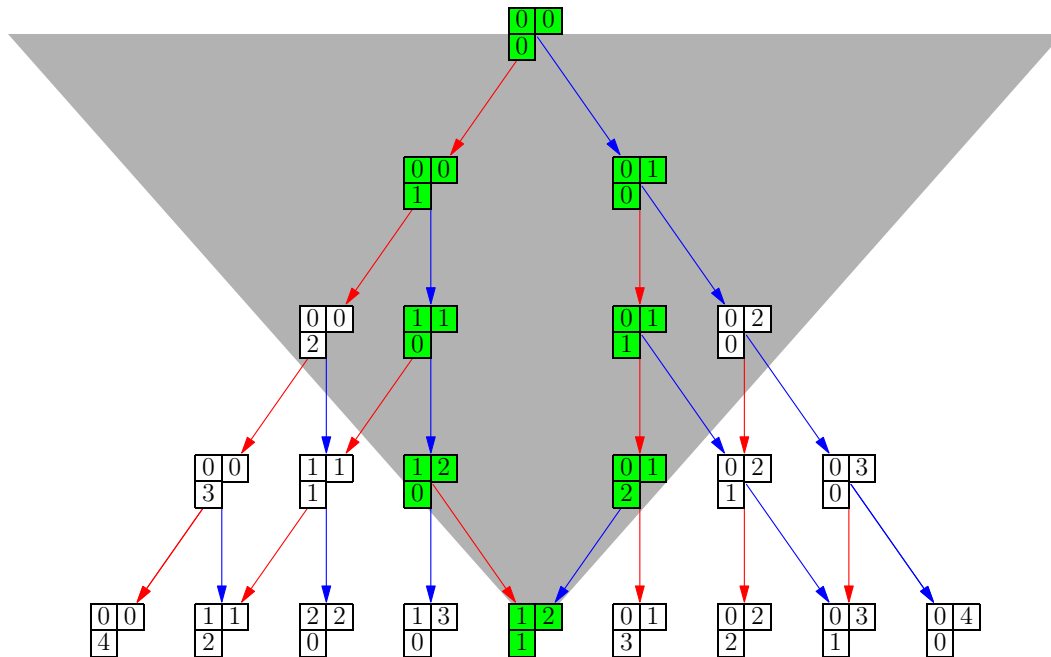

upper boundary: circles

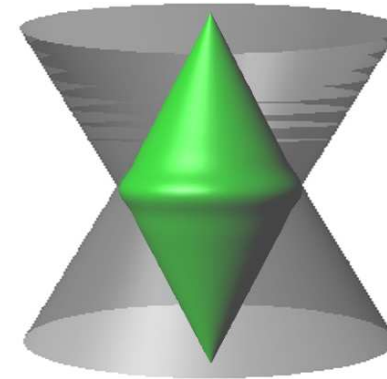

lower boundary: boxes

Similarly, we may embed $\mathcal{B}_{\lambda+\rho}$ into $\mathcal{B}_{-\infty} \otimes \mathcal{T}_{w_0(\lambda+\rho)}$. This is not drawn above, but corresponds to the gray shaded area (extending upwards).

Thus $\mathcal{B}_{\lambda+\rho}$ may be identified with the integer points in the intersection of two polyhedral cones. If a vertex lies on the boundary of one cone, the entry whose value causes it to be on the boundary is circled. If it lies on the boundary of the other cone, the entry whose value causes it to be on the boundary is boxed.

Tokuyama's Formula: Crystal Version

Tokuyama's formula may be expressed as a sum over $\mathcal{B}_{\lambda+\rho}$.

$$\prod_{\alpha \in \Delta^+} (1 - tz^{-\alpha}) \chi_{\lambda}(z) = \sum_{v \in \mathcal{B}_{\lambda+\rho}} G(v) z^{\rho - w_0(\text{wt}(v))}, \quad w_0 = \text{long element of } W.$$

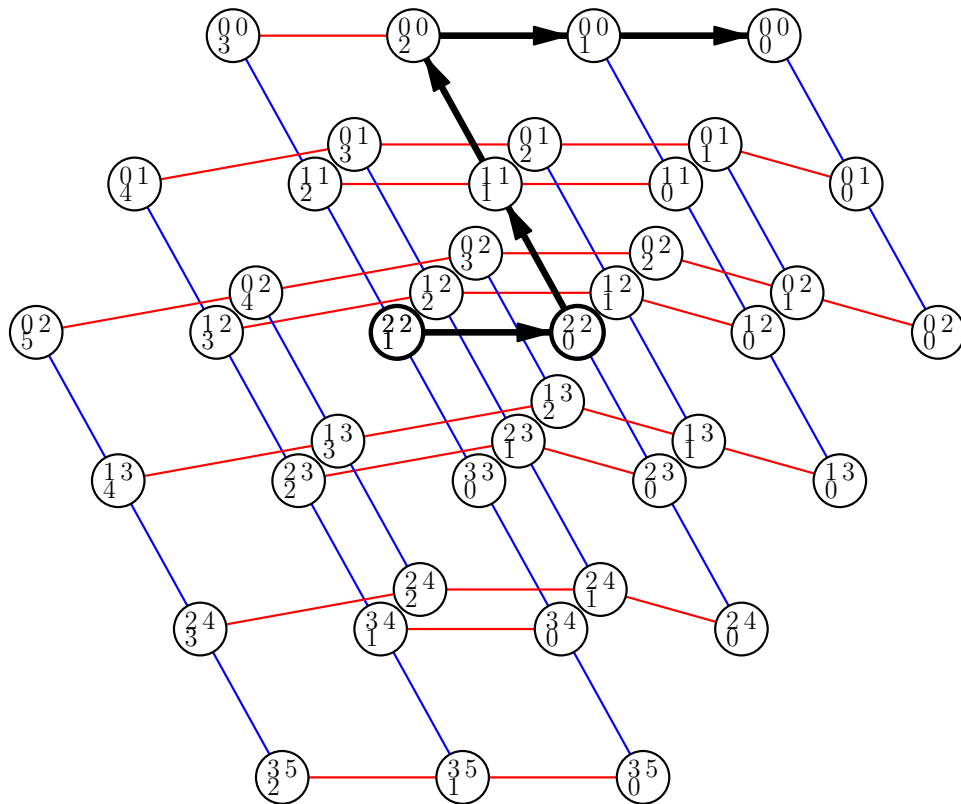

$$G(v) =$$

$$\prod_{b_i \in \text{BZL}(v)} \begin{cases} h(b_i) & \text{usually} \\ g(b_i) & b_i \text{ boxed} \\ 1 & b_i \text{ circled} \\ 0 & b_i \text{ boxed and circled} \end{cases}$$

If $n = 1$,

$$g(b) = -q^{-1}$$

$$h(b) = 1 - q^{-1}$$

$$\text{BZL}_{\Gamma}(v) = \begin{matrix} 2 \\ \boxed{1} \end{matrix} \begin{matrix} \textcircled{2} \\ \end{matrix}, \quad G_{\Gamma}(v) = g(1) \cdot q^{-2} \cdot h(2)$$

Change g and h to Gauss sums to get metaplectic Whittaker fn.

Two Words, Two Problems

Recall that we defined

$$\Omega_\Gamma = (1, 2, 1, 3, 2, 1, 4, 3, 2, 1, \dots), \quad \Omega = (r, r-1, r, r-2, r-1, r-2, \dots),$$

and either could be used in defining $\text{BZL}(v)$. **Problem 1:** to prove

Theorem 1. (Brubaker, Bump, Friedberg) *We have*

$$\sum_{v \in \mathcal{B}_{\lambda+\rho}} G_\Gamma(v) \mathbf{z}^{\text{wt}(v)} = \sum_{v \in \mathcal{B}_{\lambda+\rho}} G_\Delta(v) \mathbf{z}^{\text{wt}(v)}.$$

- This equals $\prod_{\alpha \in \Delta^+} (1 - q^{-1} \mathbf{z}^{-n\alpha}) W(t_\lambda)$, the metaplectic Whittaker function.
- In fact we could use any reduced word for the long Weyl group element w_0 and try to make this definition. However only for these two particular words do we have such a simple description.
- The equality of these two expressions is a combinatorially deep.

Problem 2 is to prove transformation properties of $\sum_{v \in \mathcal{B}_{\lambda+\rho}} G_\Gamma(v)$ for the Weyl group action on \mathbf{z} . For $n=1$ (Tokuyama) this is the symmetry of Schur functions.

About Theorem 1

$$\sum_{v \in \mathcal{B}_{\lambda+\rho}} G_{\Gamma}(v) z^{\text{wt}(v)} = \sum_{v \in \mathcal{B}_{\lambda+\rho}} G_{\Delta}(v) z^{\text{wt}(v)}.$$

It is **often** true that

$$G_{\Gamma}(v) = G_{\Delta}(v).$$

If v is in the interior of the crystal (interpreted as the set of lattice points in a convex polytope, that is, if boxing and circling don't occur, then $G_{\Gamma}(v) = G_{\Delta}(v)$. It is even usually true if v is on the boundary.

However for certain cases, the sum is definitely necessary. It is enough to prove:

$$\sum_{\substack{v \in \mathcal{B}_{\lambda+\rho} \\ \text{wt}(v) = \mu}} G_{\Gamma}(v) = \sum_{\substack{v \in \mathcal{B}_{\lambda+\rho} \\ \text{wt}(v) = \mu}} G_{\Delta}(v).$$

To accomplish this it may be necessary to combine different v in the same weight space and make use of Gauss sum identities. This can be checked in any given case but the pattern is chaotic as the possible.

An Example

Let us consider the A_2 crystal $\mathcal{B}_{\lambda+\rho}$ where $\lambda + \rho = (7, 5, 0)$. For most $v \in \mathcal{B}_{\lambda+\rho}$ we have

$$G_{\Gamma}(v) = G_{\Delta}(v).$$

This is true for 69 out of the 81 elements of the crystal.

But consider the elements v of weight $\mu = (4, 5, 3)$. There are three:

$$v_1 = \begin{array}{|c|c|c|c|c|c|c|} \hline 1 & 1 & 1 & 1 & 2 & 3 & 3 \\ \hline 2 & 2 & 2 & 2 & 3 & & \\ \hline \end{array}, \quad v_2 = \begin{array}{|c|c|c|c|c|c|c|} \hline 1 & 1 & 1 & 1 & 2 & 2 & 3 \\ \hline 2 & 2 & 2 & 3 & 3 & & \\ \hline \end{array}, \quad v_3 = \begin{array}{|c|c|c|c|c|c|c|} \hline 1 & 1 & 1 & 1 & 2 & 2 & 3 \\ \hline 2 & 2 & 2 & 2 & 2 & & \\ \hline \end{array}.$$

We have

$$G_{\Gamma}(v_2) = G_{\Delta}(v_2) = h(1)h(2)h(3)$$

However this fails for v_1 and v_3 which must be considered a “packet” not to be subdivided.

| v | $\text{BZL}_{\Gamma}(v)$ | $G_{\Gamma}(v)$ |
|-------|---------------------------------------------------------------------------------|-----------------|
| v_1 | $\begin{array}{ c } \hline 2 \\ \hline 1 \\ \hline \end{array} 3$ | $g(2)h(3)g(1)$ |
| v_2 | $\begin{array}{ c } \hline \textcircled{0} \\ \hline 3 \\ \hline \end{array} 3$ | $h(3)^2$ |

| v | $\text{BZL}_{\Delta}(v)$ | $G_{\Delta}(v)$ |
|-------|-----------------------------------------------------------------------------------------------|-----------------|
| v_1 | $1 \begin{array}{ c } \hline 3 \\ \hline \end{array}$ | $h(1)g(3)h(2)$ |
| v_2 | $3 \begin{array}{ c } \hline \textcircled{3} \\ \hline \textcircled{0} \\ \hline \end{array}$ | $h(3)g(3)$ |

$$g(2)h(3)g(1) + h(3)^2 = h(1)g(3)h(2) + h(3)g(3).$$

This identity is needed. Both sides vanish unless $n = 1$ or 3 .

Ice Models

There is another approach to metaplectic Whittaker functions based on the six-vertex model of statistical physics. We will describe a statistical mechanical model \mathfrak{S} . It has a set $S(\mathfrak{S})$ of states, and for each state $v \in S(\mathfrak{S})$ a **Boltzmann weight** $G(v)$. The **partition function** is $Z(\mathfrak{S}) = \sum G(v)$.

Begin with a grid, usually (but not always) rectangular:

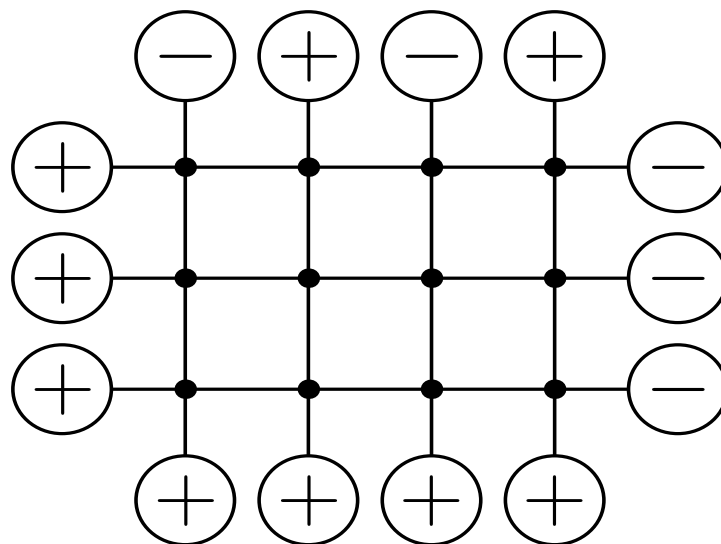

Each exterior edge is assigned a fixed **spin** + or -. The inner edges are also assigned spins but these will vary.

Six Vertex Model

A **state** of the model is an assignment of spins to the inner edges. (The outer edges have preassigned spins. Every vertex is assigned a set of **Boltzmann weights**. These depend on the spins of the four adjacent edges. For the six-vertex model there are only six nonzero Boltzmann weights (depending on the vertex v).

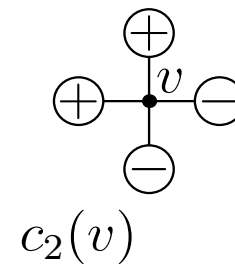
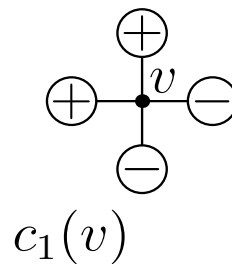
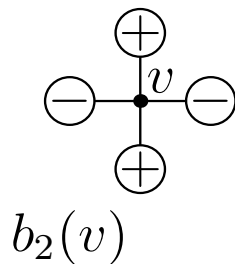
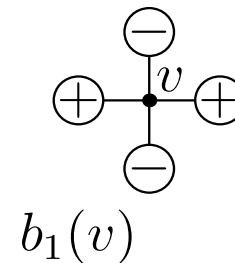
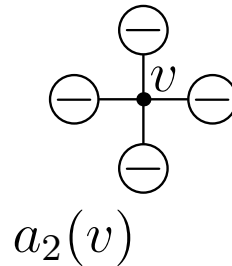
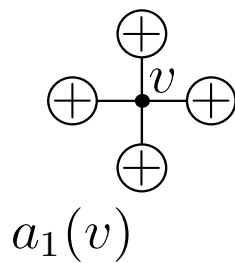

The **Boltzmann weight** of the state is the product of the weights at the vertices. The **partition function** is the sum over the states of the system.

Metaplectic Ice

Brubaker, Bump, Friedberg, Chinta and Gunnells showed how to choose Boltzmann weights to produce the metaplectic Whittaker function. The spin on horizontally oriented edges must be augmented by an index a which is an integer mod n . There are two flavors of weights. First **Gamma ice**:

| | | | | | | |
|----------|---|-------|--------|-------|-----------|---|
| Γ | | | | | | |
| | 1 | z_i | $g(a)$ | z_i | $h(a)z_i$ | 1 |

Second, **Delta ice**:

| | | | | | | |
|----------|-------|------------|---|-------|-----------|---|
| Δ | | | | | | |
| | z_i | $z_i g(a)$ | 1 | z_i | $h(a)z_i$ | 1 |

With suitable boundary conditions, the partition function is $\prod_{\alpha \in \Delta^+} (1 - q^{-1} z^{-n\alpha}) W(t_\lambda)$.

Same Problems, Different Tools

The equivalence of the two points of view is straightforward to show. There is an embedding of the set of states of the statistical mechanical system into $\mathcal{B}_{\lambda+\rho}$ and the elements of $\mathcal{B}_{\lambda+\rho}$ that are in the image of the mapping are precisely those for which $G(v)$ is nonzero. So the two sums are term-by-term equivalent.

The statistical-mechanical view makes available a new tool: the **Yang-Baxter equation**.

Transfer Matrices

Given one row of ice, with Boltzmann weights S at each vertex the partition function depends on the top row α and the bottom row β . It may be thought of as a matrix $\Sigma_{\alpha,\beta}^S$.

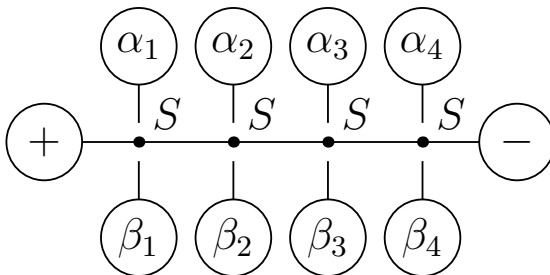

Commutativity of Transfer Matrices

Now given a second set of Boltzmann weights the partition function

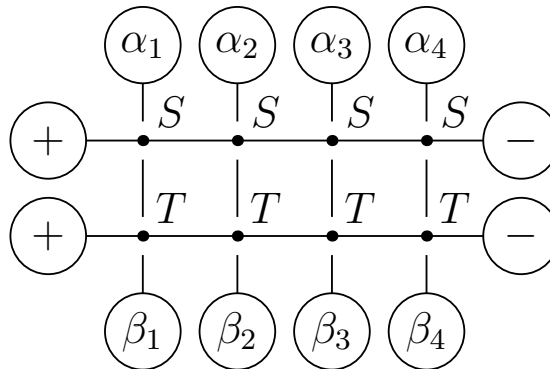

is computed from the row transfer matrices Σ^S and Σ^T by matrix multiplication. If it equals the partition function of

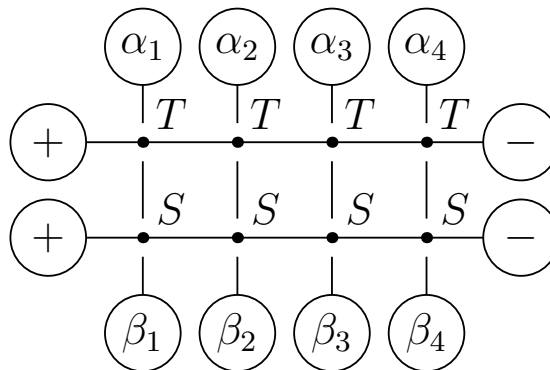

for all α, β then the transfer matrices Σ^S and Σ^T commute.

Yang-Baxter Equation

Baxter introduced a powerful method for proving commutativity of transfer matrices. It may be that Boltzmann weights corresponding to a vertex R may be found such that the partition functions:

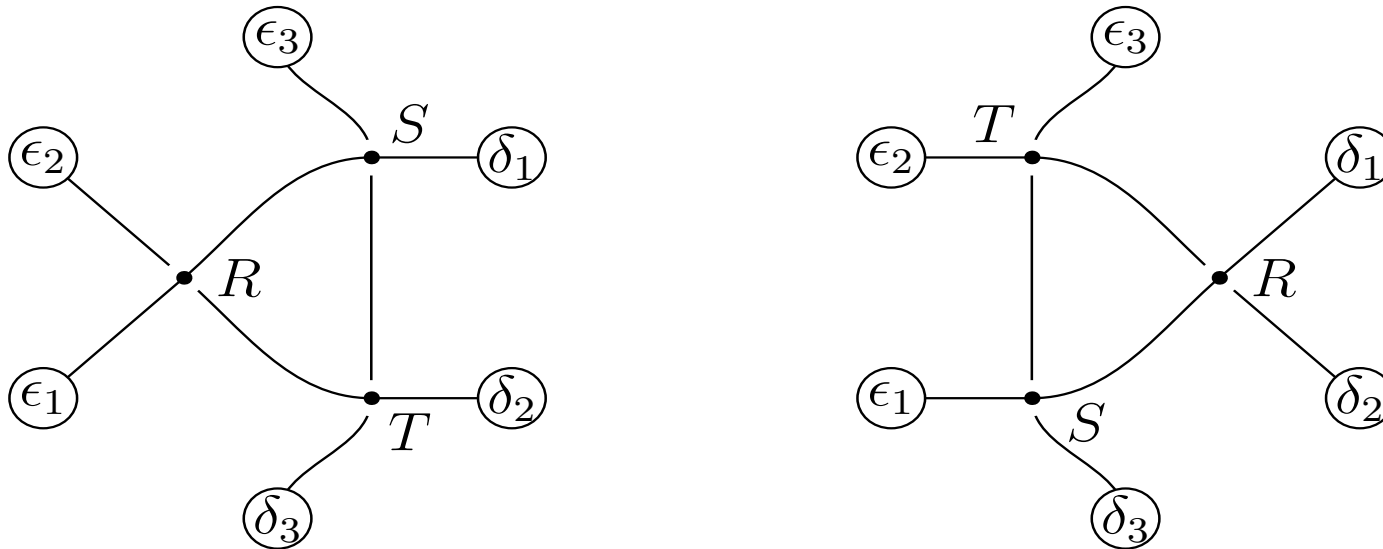

are equal for all boundary values. This can be used to prove things like the commutativity of Σ^S and Σ^T .

- Both **Problem 1** and **Problem 2** can be formulated in terms of commuting transfer matrices.
- If $n = 1$ they can be solved using Yang-Baxter equation.
- If $n > 1$ the results can be proved but only by other methods.

How YBE is used

It is assumed that the only nonzero Boltzmann weight for the vertex R with $\varepsilon_1 = \varepsilon_2 = +$ has also $\varepsilon_3 = \varepsilon_4 = +$, and that this Boltzmann weight is 1.

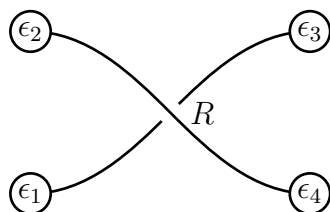

If so, attaching R as shown does not change the partition function (left, below).

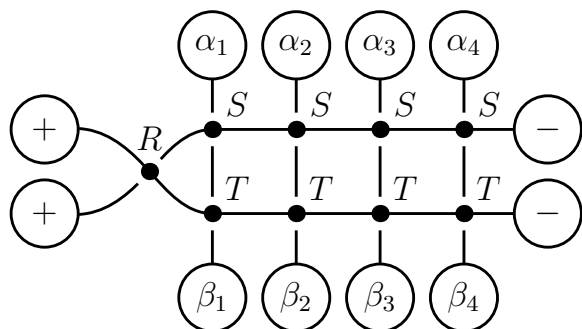

Now use the Yang-Baxter equation repeatedly, which interchanges S and T in every column.

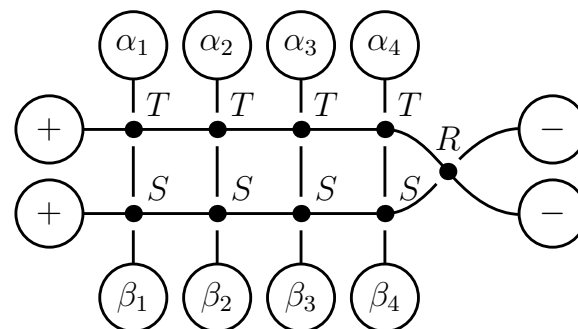

Assuming the only nonzero weight with $\varepsilon_3 = \varepsilon_4 = -$ also has $\varepsilon_1 = \varepsilon_2 = -$, we may now discard the R-matrix and the commutativity of transfer matrices is proved.

Back to Crystals

If $n > 1$ we don't know how to use the Yang-Baxter Equation to prove Theorem 1 so we return to crystals. We will use Gelfand-Tsetlin patterns (GTP) in place of tableaux.

| | | | |
|---|---|---|---|
| 1 | 1 | 2 | 3 |
| 2 | 3 | | |

corresponds to the pattern

$$\mathfrak{T}_\Gamma(v) = \left\{ \begin{array}{cccc} 4 & 2 & & 0 \\ & 3 & 1 & \\ & & 2 & \end{array} \right\}$$

The i -th row from the bottom in the GT pattern is the shape of the tableau after removing all entries $> i$.

Crystals admit the following operations (Lascoux and Schützenberger, Kashiwara).

- The **Schützenberger involution**, which interchanges the highest and lowest weight vector, and interchanges e_i with f_{r+1-i} . It is a crystal graph automorphism.
- An action of the Weyl group. The reflection s_i simply reverses the i -labeled root strings. The Weyl group operations are not graph automorphisms.

These maps have been usefully translated into GTP by Kirillov and Berenstein.

Two Parametrizations by Gelfand Tsetlin Patterns

The Γ parametrization is not the only one we use. Recall that

| | | | |
|---|---|---|---|
| 1 | 1 | 2 | 3 |
| 2 | 3 | | |

corresponds to the pattern

$$\mathfrak{T}_\Gamma(v) = \left\{ \begin{array}{cccc} 4 & & & 0 \\ & 2 & & \\ & & 1 & \\ & & & 2 \end{array} \right\}$$

The i -th row from the bottom in the GT pattern is the shape of the tableau after removing all entries $> i$.

It will be convenient to make use of a second parametrization

$$v = \begin{array}{|c|c|c|c|} \hline 1 & 1 & 1 & 2 \\ \hline 3 & 3 & & \\ \hline \end{array} \longrightarrow (\text{Schützenberger}) \begin{array}{|c|c|c|c|} \hline 1 & 1 & 3 & 3 \\ \hline 2 & 3 & & \\ \hline \end{array} \longrightarrow \mathfrak{T}_\Delta(v) = \left\{ \begin{array}{ccc} 4 & & 0 \\ & \begin{array}{c} \parallel \\ 2 \\ \parallel \\ 2 \end{array} & 1 \end{array} \right\}$$

For the Δ word, we apply the Schützenberger involution of the crystal before constructing the Gelfand-Tsetlin pattern by the same recipe. Alternatively use an algorithm for the involution due Kirillov and Berenstein.

Gelfand-Tsetlin Patterns and String (BZL) patterns

Rule for Γ word:

| | | | |
|---|---|---|---|
| 1 | 1 | 2 | 3 |
| 2 | 3 | | |

$$\left\{ \begin{array}{cccc} 4 & 2 & 0 & \\ & 3 & 1 & \\ & & 2 & \end{array} \right\}$$

It is straightforward to read off $\text{BZL}_\Gamma(v)$ from the GT pattern: in this case it is:

$$\left(\begin{array}{cc} 4-3 & (4+2) - (3+1) \\ 3-2 & \end{array} \right) = \left(\begin{array}{cc} 1 & 2 \\ 1 & \end{array} \right)$$

We consider the consecutive differences between rows, accumulating from left to right.

Circling occurs when one of the entries equals the entry above it and to the left. Boxing occurs when it equals the entry above and to the right.

| | | | |
|---|---|---|---|
| 1 | 1 | 1 | 2 |
| 3 | 3 | | |

$$\left\{ \begin{array}{ccc} 4 & 2 & 0 \\ \parallel & & \parallel \\ 4 & & 0 \\ & & \\ & & 3 \end{array} \right\}$$

$$\left(\begin{array}{cc} 4-4 & (4+2) - (4+0) \\ 4-3 & \end{array} \right) = \left(\begin{array}{cc} \textcircled{0} & \boxed{2} \\ 1 & \end{array} \right)$$

△ Word:

To calculate the BZL pattern from this Gelfand-Tsetlin pattern, we use a modified algorithm. We still subtract between rows, but we subtract the entry above and to the left, and accumulate from right to left. For this reason, we will draw the BZL pattern the mirror image of the Γ convention. (Now the rows are decreasing.)

$$\left\{ \begin{array}{ccc} 4 & & 0 \\ & \begin{array}{c} \parallel \\ 2 \\ \parallel \\ 2 \end{array} & 1 \end{array} \right\} \quad \left(\begin{array}{cc} (2+1) - (2+0) & 1-0 \\ & 2-1 \end{array} \right) = \left(\begin{array}{cc} \textcircled{1} & 1 \\ & \boxed{1} \end{array} \right)$$

Now recall Theorem 1, which we are trying to show. It is enough to show for weight μ :

$$\sum_{\substack{v \in \mathcal{B}_{\lambda+\rho} \\ \text{wt}(v) = \mu}} G_{\Gamma}(v) = \sum_{\substack{v \in \mathcal{B}_{\lambda+\rho} \\ \text{wt}(v) = \mu}} G_{\Delta}(v).$$

Short Patterns

Using the involution and partial involutions, it is possible to reduce to a problem involving just three rows of the Gelfand-Tsetlin pattern. We regard the top and bottom row as being fixed, and the middle row variable. For example, let

$$t = \left\{ \begin{array}{cccccc} 23 & 15 & 12 & 5 & 2 & 0 \\ & 20 & 12 & 5 & 4 & 2 \\ & & 14 & 9 & 5 & 3 \end{array} \right\}.$$

We form a BZL array as above, using the Δ convention for the first two rows, and the Γ convention for the second and third row. Thus in this case we obtain

$$\text{BZL}_{\Delta\Gamma}(t) = \left\{ \begin{array}{cccc} 9 & \textcircled{4} & \textcircled{4} & 4 \\ & 6 & 9 & \textcircled{9} \\ & & & \boxed{2} \\ & & & 10 \end{array} \right\}, \quad G_{\Delta\Gamma}(t) = h(9) \cdot 1 \cdot 1 \cdot h(4)g(2)h(6)h(9)g(9)h(10).$$

Reflection

We consider the top and bottom row of the pattern fixed, and the middle row subject to variation. Given a, b in the top row and c, d in the bottom, row, with x between them:

$$\begin{array}{cc} a & b \\ & x \\ c & d \end{array}$$

x is constrained by the inequality $\min(a, c) \leq x \leq \max(b, d)$. We reflect in this range, replacing x by $x' = \min(a, c) + \max(b, d)$. Let \mathfrak{t}' be the resulting pattern. In the example

$$\mathfrak{t} = \left\{ \begin{array}{cccccc} 23 & 15 & 12 & 5 & 2 & 0 \\ & 20 & 12 & 5 & 4 & 2 \\ & & 14 & 9 & 5 & 3 \end{array} \right\} \quad \mathfrak{t}' = \left\{ \begin{array}{cccccc} 23 & 15 & 12 & 5 & 2 & 0 \\ & 18 & 14 & 9 & 4 & 0 \\ & & 14 & 9 & 5 & 3 \end{array} \right\}.$$

Now compute the BZL patterns. In \mathfrak{t} we use Δ convention in the first row and Γ in the second, while in \mathfrak{t}' , these are switched.

$$\text{BZL}_{\Delta\Gamma}(\mathfrak{t}) = \left\{ \begin{array}{cccc} 9 & \textcircled{4} & \textcircled{4} & 4 & \boxed{2} \\ & 6 & 9 & \textcircled{9} & 10 \end{array} \right\} \quad \text{BZL}_{\Gamma\Delta}(\mathfrak{t}') = \left\{ \begin{array}{cccc} 5 & 6 & 9 & 10 & \boxed{12} \\ & \textcircled{4} & \textcircled{4} & 4 & 3 \end{array} \right\}$$

The correspond Gauss sum contributions $G_{\Delta\Gamma}(\mathfrak{t})$ and $G_{\Gamma\Delta}(\mathfrak{t}')$ are:

$$h(9)g(4)g(4)g(4) \cdot 1 \cdot h(6)h(9)g(9)h(10), \quad h(5)h(6)h(9)h(10)g(12) \cdot 1 \cdot 1 \cdot h(4)h(3).$$

Crystal Interpretation

The meaning of these patterns is as follows:

$$\text{BZL}_{\Delta\Gamma}(t) = \left\{ \begin{array}{cccc} 9 & \textcircled{4} & \textcircled{4} & 4 & \boxed{2} \\ & 6 & 9 & \textcircled{9} & 10 \end{array} \right\} \quad \text{BZL}_{\Gamma\Delta}(t') = \left\{ \begin{array}{cccc} 5 & 6 & 9 & 10 & \boxed{12} \\ & \textcircled{4} & \textcircled{4} & 4 & 3 \end{array} \right\}$$

There is an element v of $\mathcal{B}_{\lambda+\rho}$ such that all $e_i v = 0$ except $i = 1$ and $i = r$. In other words, v is a highest weight vector for the (reducible) A_{r-2} crystal obtained by discarding the edges labeled 1 and r . Now we consider two words:

$$\omega_{\Gamma\Delta} = (1, 2, 3, \dots, r-1, r, r-1, \dots, 1), \quad \omega_{\Delta\Gamma} = (r, r-1, r-2, \dots, 3, 2, 1, 2, \dots, r).$$

Then we form the string patterns as before. The entries appear in the accordion arrays in the following order:

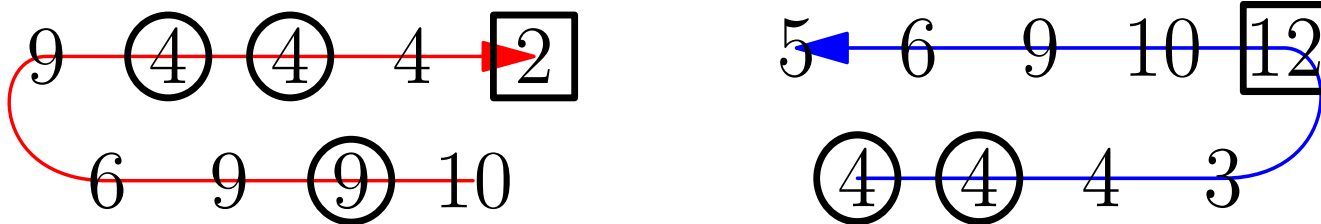

As usual we wind up at the highest weight vector.

Comparison

Theorem 2. (Brubaker, Bump, Friedberg) *Fix the top and bottom row of a short Gelfand-Tsetlin pattern and sum over all middle rows with fixed row sum. Then*

$$\sum_{\mathfrak{t}} G_{\Delta\Gamma}(\mathfrak{t}) = \sum_{\mathfrak{t}} G_{\Gamma\Delta}(\mathfrak{t}').$$

As was shown by Brubaker, Bump, Friedberg, Chinta and Gunnells, this formula is exactly equivalent to the commutativity of two transfer matrices for Gamma and Delta ice. Unfortunately, we have to prove it without the Yang-Baxter equation.

This implies Theorem 1. The phenomena discussed in that context are present here, in a simplified form: for most \mathfrak{t} , we have term by term equality $G_{\Delta\Gamma}(\mathfrak{t}) = G_{\Gamma\Delta}(\mathfrak{t}')$. When this fails, the terms have to be gathered together in “packets” and nontrivial Gauss sum identities employed.

The Snake Lemma

Let us show that if \mathfrak{t} is in the interior of crystal then $G_{\Delta\Gamma}(\mathfrak{t}) = G_{\Gamma\Delta}(\mathfrak{t}')$.

This follows from the **Snake Lemma** which asserts that we may order the entries in $\text{BZL}_{\Delta\Gamma}(\mathfrak{t})$ and $\text{BZL}_{\Gamma\Delta}(\mathfrak{t}')$ in a special way. We may arrange that

$$\text{BZL}_{\Delta\Gamma}(\mathfrak{t}) = \{\gamma_1, \gamma_2, \dots, \gamma_{2r-1}\},$$

$$\text{BZL}_{\Gamma\Delta}(\mathfrak{t}') = \{\gamma_1 - \gamma_2, \gamma_2, \gamma_2 + \gamma_3 - \gamma_4, \gamma_4, \dots, \gamma_{2r-2}, \gamma_{2r-2} + \gamma_{2r}\}.$$

(The even entries are the same, while if k is odd, we have $\gamma_{k-1} + \gamma_k - \gamma_{k+1}$.)

Now since we are in the interior there is no boxing or circling, and

$$G_{\Delta\Gamma}(\mathfrak{t}) = h(\gamma_1)h(\gamma_2)\cdots h(\gamma_{2r-1}) = \begin{cases} (1 - q^{-1})^{2r-1} & \text{if } n \mid \gamma_1, \gamma_2, \dots, \gamma_{2r-1} \\ 0 & \text{otherwise.} \end{cases}$$

The entries in $\text{BZL}_{\Gamma\Delta}(\mathfrak{t}')$ have the same greatest common divisor, so $G_{\Gamma\Delta}(\mathfrak{t}')$ is the same.

Illustrating the Snake Lemma

$$t = \begin{pmatrix} 23 & 15 & 12 & 5 & 2 & 0 \\ & 20 & 12 & 5 & 4 & 2 \\ & & 14 & 9 & 5 & 3 \end{pmatrix} \quad t' = \begin{pmatrix} 23 & 15 & 12 & 5 & 2 & 0 \\ & 18 & 14 & 9 & 4 & 0 \\ & & 14 & 9 & 5 & 3 \end{pmatrix}.$$

Follow the snake: $\text{BZL}_{\Delta\Gamma}(t) = \left\{ \begin{array}{c} 9 \xrightarrow{4} 4 \xrightarrow{4} 4 \xrightarrow{4} 4 \xrightarrow{2} 2 \\ \leftarrow 6 \leftarrow 9 \leftarrow 9 \leftarrow 10 \end{array} \right\}$

$$\text{BZL}_{\Gamma\Delta}(t') = \left\{ \begin{array}{c} 5 \xrightarrow{4} 6 \xrightarrow{4} 9 \xrightarrow{4} 10 \xrightarrow{2} 12 \\ \leftarrow 4 \leftarrow 4 \leftarrow 4 \leftarrow 3 \end{array} \right\}$$

$$\{\gamma_1 - \gamma_2, \gamma_2, \gamma_2 + \gamma_3 - \gamma_4, \gamma_4, \dots\} = \{9 - 4, 4, 4 + 6 - 4, 4, 4 + 9 - 4, 4, 4 + 9 - 10, 10, 10 + 2\}.$$

$$\{\gamma_1, \gamma_2, \dots, \gamma_9\} = \{9, 4, 6, 4, 9, 4, 9, 10, 2\}.$$

Totally Resonant Case

Fix the top and bottom rows of a short Gelfand-Tsetlin pattern.

$$\mathfrak{t} = \left\{ \begin{array}{cccccccc} L_0 & L_1 & L_2 & \cdots & L_{r-1} & L_r \\ & a_0 & a_1 & \cdots & a_{r-1} & a_r \\ & & M_1 & M_2 & & M_{r-1} \end{array} \right\}.$$

If no $L_i = M_i$, then by a similar argument using the Snake Lemma, we may show that $G_{\Delta\Gamma}(\mathfrak{t}) = G_{\Gamma\Delta}(\mathfrak{t}')$. If $L_i = M_i$ then we say there is **resonance** and we may expect to find packets. We may reduce to the **totally resonant** case where all $L_i = M_i$.

$$\mathfrak{t} = \left\{ \begin{array}{cccccccc} L_0 & L_1 & L_2 & \cdots & L_{r-1} & L_r \\ & a_0 & a_1 & \cdots & a_{r-1} & a_r \\ & & L_1 & L_2 & \cdots & L_{r-1} \end{array} \right\}.$$

Now the BZL patterns have a special form:

$$\mathfrak{t} = \left\{ \begin{array}{cccccc} s & \phi_1 & \phi_2 & \cdots & \phi_d \\ & \psi_1 & \psi_2 & \cdots & \psi_d \end{array} \right\}, \quad \phi_i + \psi_i = s, \quad n|s.$$

$$\mathfrak{t}' = \left\{ \begin{array}{cccccc} \psi_1 & \psi_2 & \cdots & \psi_d & s \\ & \phi_1 & \phi_2 & \cdots & \phi_d \end{array} \right\}.$$

Now ψ_i is boxed or circled if and only if ϕ_i is !

Resotopes

The patterns now may be interpreted as lattice points in a convex polytope:

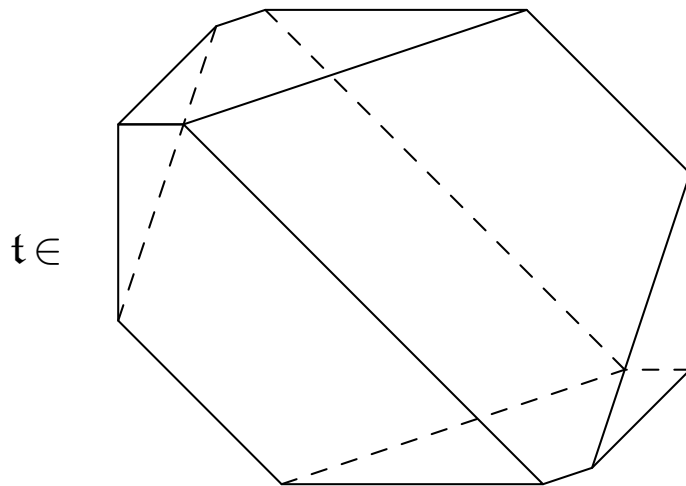

$$\mathfrak{t} = \left\{ \begin{array}{cccccccc} s & \phi_1 & \phi_2 & \dots & \phi_d \\ \psi_1 & \psi_2 & \dots & \psi_d \end{array} \right\}.$$

We may assume that $n|s$ since otherwise both terms vanish.

Inclusion-Exclusion

The problem is still complex but the following may be carried out. The **resotope** above may be obtained by cutting the corners off a simplex. The sum may be obtained by summing over the **entire simplex** and a process of Möbius inversion (inclusion-exclusion). What is summed is over the simplices is an alternating sum over **signatures** that describe the boxing and circling of the ϕ_i and ψ_i .

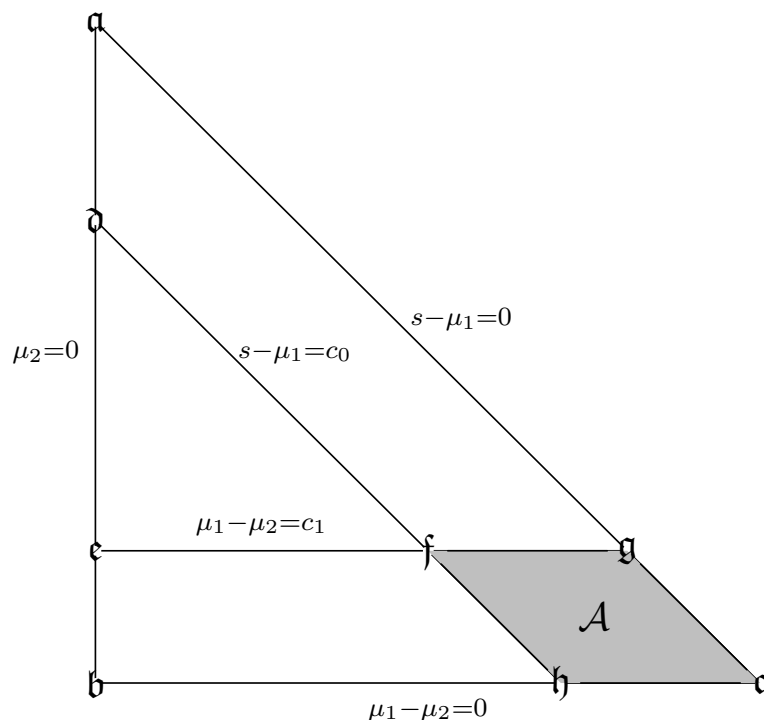

Sum over the resotope \mathcal{A} is reduced to a sum over a simplex.

Although these alternating sums seem more complex they are actually simpler!

After this modification the problem may be solved.

Conclusion

We see that the key result needed to prove Theorem 2 may be formulated in terms of commutativity of transfer matrices for Γ and Δ ice.

Given Theorem 2 the proof of Theorem 1 parallels the proof of the same fact using the Yang-Baxter equation (available only when $n = 1$). Given a system of Γ ice, we may change the bottom row to Δ ice. Then use commutativity of transfer matrices to move this row to the top, and repeat the process until done.

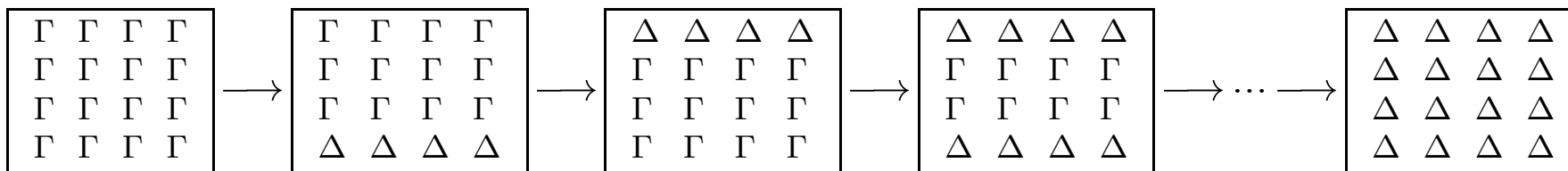

If $n > 1$, the needed Yang-Baxter equation is not available despite serious efforts to find it. The advantages of having it would go beyond simplification of these difficult arguments. Drinfeld, Faddeev-Takhtajan-Reshetikhin, Majid and others has shown how solutions of the Yang-Baxter equation gives rise to a module or family of modules in a braided category, which can in turn be realized as the category of modules or comodules over a **quantum group**. Thus Baxter's work on the six vertex module leads to $U_q(\hat{\mathfrak{sl}}_2)$.

Thus giving a proof of Theorem 2 using a Yang-Baxter equation could lead to interesting new quantum groups.