

Crystals of Type B and Metaplectic Whittaker Functions

Brubaker, Bump, Chinta and Gunnells

May 11, 2010

Let n be an integer and let F be a nonarchimedean local field whose characteristic is not a prime dividing n . Let μ_k be the group of k -th roots of unity in the algebraic closure of F ; we assume that $\mu_{2n} \subset F$. Let G be a split, simply-connected semisimple algebraic group over F . We assume that G is actually defined over the ring \mathfrak{o} of integers in F in such a way that $K = G(\mathfrak{o})$ is a special maximal compact subgroup of $G(F)$.

Matsumoto [19] constructed an n -fold metaplectic cover $\tilde{G}(F)$ of $G(F)$. For this, we only need $\mu_n \subset F$ but the hypothesis $\mu_{2n} \subset F$ simplifies the metaplectic cocycle and the resulting formulas. We are interested in values of a spherical Whittaker function W on $\tilde{G}(F)$.

Let $G = \mathrm{Sp}_{2r}$ and let $n = 2$. In this case, we present two representations of the Whittaker function.

- Bump, Friedberg and Hoffstein [7] gave a description of the Whittaker function, essentially as a sum of up to 2^r irreducible characters of $\mathrm{Sp}(2r)$, that is, of Cartan type C_r .
- Chinta and Gunnells [13] gave a recipe for the p -parts of Weyl group multiple Dirichlet series. We will show that this agrees with the description of the Whittaker function in [7].

In addition to these descriptions, we have three other conjectural formulas for the metaplectic Whittaker function. Let λ denote a dominant weight for the root system of Cartan type B_r . Let t_λ be an element of the split maximal torus parametrized by λ . Then:

- The value of the Whittaker function W at t_λ may be expressed as a sum over the Kashiwara crystal \mathcal{B}_λ . (Conjecture 1.)

- The value $W(t_\lambda)$ may be expressed as a sum over the Kashiwara crystal $\mathcal{B}_{\lambda+\rho}$, where ρ is the Weyl vector. (Conjecture 2.)
- The value may be expressed as the partition function for a statistical model. (Conjecture 3).

The second and third conjectural descriptions are easily seen to be equivalent but give rise to very different considerations. Although these statements are only partially proved, they are convincingly supported by calculations.

An interesting feature of this situation is the interplay between Type B descriptions and Type C descriptions.

The Classical Case: The Casselman-Shalika formula

Before considering this problem, let us review the situation when $n = 1$, so that $G(F)$ and $\tilde{G}(F)$ are the same. Let Λ be the weight lattice of the connected L-group ${}^L G^\circ$. It is the group $X({}^L T)$ of rational characters of a maximal torus ${}^L T$ of ${}^L G^\circ$. If $\lambda \in \Lambda$ and $\mathbf{z} \in {}^L T$ we will denote by \mathbf{z}^λ the value of λ at \mathbf{z} . Let Φ be the root system of ${}^L G^\circ$, so that the root system of G is the dual root system $\hat{\Phi}$.

If T is an F -split torus of G , then $\Lambda \cong T(F)/T(\mathfrak{o})$. If $\lambda \in \Lambda$, let t_λ be a representative of its coset in $T(F)$. Unramified quasicharacters of $T(F)$ correspond to elements of ${}^L T$. Indeed, an unramified quasicharacter ξ of $T(F)$ is a quasicharacter that is trivial on $T(\mathfrak{o})$, that is, a character of Λ , and so there is an element $\mathbf{z} \in {}^L T$ such that $\xi(t_\lambda) = \mathbf{z}^\lambda$. In this case, we write $\xi = \xi_{\mathbf{z}}$.

If α is a positive root, then the coroot α^\vee is a positive root of G with respect to T . Let X_{α^\vee} be the corresponding root eigenspace in $\text{Lie}(G)$, and let N be the maximal unipotent subgroup with Lie algebra $\bigoplus_{\alpha \in \Phi^+} X_{\alpha^\vee}$. Then $B = TN$ is a Borel subgroup.

Let ψ_N be a nondegenerate character of N . Then ψ_N is trivial on $\exp(X_{\alpha^\vee})$ if α is positive root that is not simple. If α is a simple positive root then we may arrange that ψ_N is trivial on $\exp(X_{\alpha^\vee}) \cap K$ but no larger subgroup of $\exp(X_{\alpha^\vee})$.

Let $\xi = \xi_{\mathbf{z}}$ be a character of $T(F)$, which we extend to a character of $B(F)$ by taking $N(F)$ to be in the kernel. Let δ be the modular quasicharacter of $B(F)$. The normalized induced representation $\pi(\xi)$ consists of all locally constant functions $f : G(F) \rightarrow \mathbb{C}$ such that $f(bg) = (\xi\delta^{1/2})(b)f(g)$, with $G(F)$ acting by right translation. The standard spherical vector f° is the unique function such that $f^\circ(k) = 1$ for $k \in K$. Let w_0 be a representative of the long Weyl group element. We may assume

that $w_0 \in K$. Then the spherical Whittaker function is

$$W(g) = \int_{N(F)} f^\circ(w_0 n g) \psi_N(n) dn. \quad (1)$$

If $\xi = \xi_z$ then the integral is convergent provided $|z^\alpha| < 1$ for $\alpha \in \Phi^+$. For other z it may be defined by analytic continuation from this domain.

According to the formula of Casselman and Shalika [8] we have $W(t_\lambda) = 0$ unless the weight λ is dominant, and if λ is dominant, then

$$W(t_\lambda) = \prod_{\alpha \in \Phi^+} (1 - q^{-1} z^\alpha) \chi_\lambda(z), \quad (2)$$

where χ_λ is the irreducible character of ${}^L G^\circ$ with highest weight λ and q is the cardinality of the residue field.

Let \mathcal{B}_λ be the Kashiwara crystal with highest weight λ , so that

$$\chi_\lambda(z) = \sum_{v \in \mathcal{B}_\lambda} z^{\text{wt}(v)}. \quad (3)$$

Ignoring the normalizing constant $\prod_{\alpha \in \Phi^+} (1 - q^{-1} z^\alpha)$ in (2), this could be regarded as a formula for the Whittaker function.

We note that by the Weyl character formula

$$\prod_{\alpha \in \Phi^+} (1 - z^\alpha) \chi_\lambda(z) = \sum_{w \in W} (-1)^{l(w)} z^{w(\rho+\lambda)+\rho}, \quad \rho = \frac{1}{2} \sum_{\alpha \in \Phi^+} \alpha.$$

The factor $\prod_{\alpha \in \Phi^+} (1 - z^\alpha)$ is the *Weyl denominator* and the factor $\prod_{\alpha \in \Phi^+} (1 - q^{-1} z^\alpha)$ which appears in (2) is a deformation of this factor.

We are therefore interested in deformations of the Weyl character formula in which the deformed denominator appears. A typical such formula will have the form

$$\prod_{\alpha \in \Phi^+} (1 - q^{-1} z^\alpha) \chi_\lambda(z) = \sum_{v \in \mathcal{B}_{\lambda+\rho}} G(v) z^{\text{wt}(v)}, \quad (4)$$

where $\mathcal{B}_{\lambda+\rho}$ is the Kashiwara crystal with highest weight $\lambda+\rho$. We will call a function G on $\mathcal{B}_{\lambda+\rho}$ which satisfies this identity a *Tokuyama function*. The archetype is the formula of Tokuyama [21], where it was stated in the language of Gelfand-Tsetlin patterns, and translated into the crystal language in [4]. This is for Cartan type A. For Cartan type C, see [1] in this volume.

For general n , we may define the metaplectic Whittaker function by an integral generalizing (1), and then ask for a formula of the form

$$W(t_\lambda) = \delta^{1/2}(t_\lambda) \sum_{v \in \mathcal{B}_{\lambda+\rho}} G(v) \mathbf{z}^{\text{wt}(v)}. \quad (5)$$

We will give analogs of both (3) and (4) for the metaplectic Whittaker function on the double cover of $\text{Sp}_{2r}(F)$. However this is the *only* metaplectic example where we have an analog of (3), whereas analogs of (4) may be found in many cases of group and degree of metaplectic cover:

- $G = \text{SL}_n$ and any n : [4], [5], [6].
- $G = \text{Spin}(2r + 1)$ and n odd: [1] (rigorously for $n = 1$ or n sufficiently large).
- $G = \text{Spin}(2r)$ and n even: [9].
- $G = \text{Sp}(2r)$ and n even: this paper (rigorously for $n = 2$).

The Metaplectic Whittaker Function

We review the formula for the metaplectic Whittaker function on the double cover of $\text{Sp}_{2r}(F)$ which was found by Bump, Friedberg and Hoffstein. We are assuming that $\mu_4 \subset F$, which simplifies the formula slightly, since the quadratic Hilbert symbol $(-1, a)_2 = (a, a)_2 = 1$ because -1 is a square.

Let $\text{Sp}_{2r} = \{g \in \text{GL}_{2r} \mid gJ^t g = J\}$, where $J = \begin{pmatrix} & -J_r \\ J_r & \end{pmatrix}$, $J_r = \begin{pmatrix} & & & 1 \\ & & \ddots & \\ & & & \\ 1 & & & \end{pmatrix}$.

The metaplectic cocycle defining the double cover satisfies

$$\sigma \left(\begin{pmatrix} x_1 & & & & & \\ & \ddots & & & & \\ & & x_r & & & \\ & & & x_r^{-1} & & \\ & & & & \ddots & \\ & & & & & x_1^{-1} \end{pmatrix}, \begin{pmatrix} y_1 & & & & & \\ & \ddots & & & & \\ & & y_r & & & \\ & & & y_r^{-1} & & \\ & & & & \ddots & \\ & & & & & y_1^{-1} \end{pmatrix} \right) = \prod (x_i, y_i)_2.$$

The double cover $\widetilde{\text{Sp}}_{2r}(F)$ consists of pairs (g, ε) with $g \in \text{Sp}_{2r}(F)$ and $\varepsilon = \pm 1$. The multiplication is $(g, \varepsilon)(g', \varepsilon') = (gg', \varepsilon\varepsilon'\sigma(g, g'))$. Let $\Lambda_C = \mathbb{Z}^r$; in the next section we will interpret this as the weight lattice of Cartan Type C_r . An element

Let us combine the two most important parts of this formula and write

$$W(\lambda) = \prod_i (1 + q^{-\frac{1}{2}} z_i) \prod_{i < j} (1 - q^{-1} z_i z_j^{-1})(1 - q^{-1} z_i z_j) \times \frac{1}{\Delta_C} \mathcal{A} \left(z^{\lambda + \rho_C} \prod_{k=1}^r (1 - q^{-1/2} z_k^{-1}) \right). \quad (6)$$

We note that in this context λ is integral and that $\lambda + \rho_B$ is half-integral. But (6) makes sense if λ is half-integral. Furthermore, the Whittaker function can be extended to the larger group GSp_{2r} . It is natural to expect that our results can be extended to GSp_{2r} , and that the values of (6) when λ is half-integral are to be interpreted as values of the Whittaker function on GSp_{2r} . Although we cannot confirm this when λ is half-integral, we will make some observations about the values of (6) in this case.

An Embarrassment of L-groups

Although Langlands only defined an L-group for algebraic groups, there is a natural candidate for an L-group of $\tilde{G}(F)$ when G is split. For $G = \mathrm{Sp}_{2r}$, it is natural to assume that the L-group should be:

$$\begin{cases} \mathrm{Sp}_{2r}(\mathbb{C}) & \text{if } n \text{ is even,} \\ \mathrm{Spin}_{2r+1}(\mathbb{C}) & \text{if } n \text{ is odd.} \end{cases}$$

For example, the alternation of the Cartan type of the L-group is suggested by Savin [20], who found that the Cartan type of the genuine part of the Iwahori Hecke algebra was isomorphic to that of $\mathrm{Sp}_{2r}(F)$ if n is odd and of $\mathrm{Spin}_{2r+1}(F)$ if n is even, suggesting that the L-group of the metaplectic should be isomorphic to the L-groups of these groups. Thus we may provisionally expect that in generalizing the Casselman-Shalika formula to the double cover of Sp_{2r} the role of ${}^L G^\circ$ should be played by $\mathrm{Sp}_{2r}(\mathbb{C})$, and indeed, such a generalization was found by Bump, Friedberg and Hoffstein [7].

It is therefore a little surprising that in generalizing (5) the relevant crystal \mathcal{B}_λ is not of type C_r but rather of type B_r ! In explaining this, both the representations of $\mathrm{Sp}_{2r}(\mathbb{C})$ (type C_r) and $\mathrm{Spin}_{2r+1}(\mathbb{C})$ (type B_r) will play a role.

We will compare these representation theories by the *ad hoc* method of identifying the ambient spaces of their weight lattices. The weight lattice Λ_C of type C_r is \mathbb{Z}^r . The lattice Λ_C has index two in the weight lattice Λ_B of type B_r . The lattice Λ_B consists of $\lambda = (\lambda_1, \dots, \lambda_r) \in \frac{1}{2}\mathbb{Z}^r$ such that all $\lambda_i - \lambda_j \in \mathbb{Z}$. The Weyl group W of

type B_r is the same as the Weyl group of type C_r ; acting on Λ_B or Λ_C , it is generated by simple reflections $\sigma_1, \dots, \sigma_r$ where σ_i acting on $\Lambda = \mathbb{Z}^r$ interchanges λ_i and λ_{i+1} in $\lambda = (\lambda_1, \dots, \lambda_r)$ when $i < r$, and σ_r sends $\lambda_r \rightarrow -\lambda_r$. The Weyl vector ρ of any root system is half the sum of the positive roots, or the sum of the fundamental dominant weights. The Weyl vectors for B_r and C_r are

$$\rho_B = \left(r - \frac{1}{2}, r - \frac{3}{2}, \dots, \frac{1}{2} \right), \quad \rho_C = (r, r - 1, \dots, 1).$$

If $\lambda \in \Lambda_C$ is a dominant weight, then the irreducible character of $\mathrm{Sp}_{2r}(\mathbb{C})$ with highest weight λ will be denoted χ_λ^C , and similarly if $\lambda \in \Lambda_B$ is a dominant weight, the irreducible character of $\mathrm{Spin}_{2r+1}(\mathbb{C})$ with highest weight λ will be denoted χ_λ^B . In either case, let g be an element of the relevant group. Let $\mathbf{z} = (z_1, \dots, z_r)$ be such that the eigenvalues of g are $z_i^{\pm 1}$ in the symplectic case, or such that the eigenvalues of the image of g in $\mathrm{SO}_{2r+1}(\mathbb{C})$ are $z_i^{\pm 1}$ and 1 in the spin case. Then the Weyl character formula asserts that

$$\chi_\lambda^C(g) = \frac{1}{\Delta_C} \mathcal{A}(\mathbf{z}^{\rho_C + \lambda}) \quad \text{or} \quad \chi_\lambda^B(g) = \frac{1}{\Delta_B} \mathcal{A}(\mathbf{z}^{\rho_B + \lambda})$$

depending on which case we are in, where the Weyl denominators are

$$\Delta_C = \mathcal{A}(\mathbf{z}^{\rho_C}) = \prod_{i < j} \left[(z_i^{1/2} z_j^{-1/2} - z_i^{-1/2} z_j^{1/2})(z_i^{1/2} z_j^{1/2} - z_i^{-1/2} z_j^{-1/2}) \right] \prod_i (z_i - z_i^{-1}),$$

$$\Delta_B = \mathcal{A}(\mathbf{z}^{\rho_B}) = \prod_{i < j} \left[(z_i^{1/2} z_j^{-1/2} - z_i^{-1/2} z_j^{1/2})(z_i^{1/2} z_j^{1/2} - z_i^{-1/2} z_j^{-1/2}) \right] \prod_i (z_i^{1/2} - z_i^{-1/2}).$$

In particular

$$\frac{\Delta_C}{\Delta_B} = \prod_{i=1}^r (z_i^{1/2} + z_i^{-1/2}) = \frac{\rho_C}{\rho_B} \prod_{i=1}^r (1 - z_i^{-1}). \quad (7)$$

On the face of it, the last formula has little meaning, since the Weyl denominators live on different groups. We will use it in the next section.

Ambivalence of the L-group

Let G be a reductive group over a nonarchimedean local field F . Let us consider the role of the L-group in the Casselman-Shalika formula. The semisimple conjugacy classes of ${}^L G^\circ$ parametrize the spherical representations of $G(F)$. Let π be a spherical representation and $\mathbf{z} = \mathbf{z}_\pi$ the parametrizing conjugacy class. Then the values of

the irreducible characters of $G(F)$ on \mathbf{z} equal the values of the spherical Whittaker function of π .

So we should seek a similar interpretation in the metaplectic case. Let $G = \mathrm{Sp}_{2r}(F)$ and let $\tilde{G}(F)$ be the double cover. Either $\mathrm{Sp}_{2r}(\mathbb{C})$ or $\mathrm{SO}_{2r+1}(\mathbb{C})$ will serve to parametrize the principal series representations of G .

But what about the factor:

$$\prod_i (1 + q^{-\frac{1}{2}} z_i) \prod_{i < j} (1 - q^{-1} z_i z_j^{-1})(1 - q^{-1} z_i z_j) \quad (8)$$

This is supposed to be a deformation of the Weyl denominator. The Weyl denominators of types B and C are, respectively, $\mathbf{z}^{-\rho_B}$ and $\mathbf{z}^{-\rho_C}$ times

$$\prod_i (1 - z_i) \prod_{i < j} (1 - z_i z_j^{-1})(1 - z_i z_j), \quad \prod_i (1 - z_i^2) \prod_{i < j} (1 - z_i z_j^{-1})(1 - z_i z_j).$$

Now there are two ways of looking at (8). We may write it as

$$\prod_i (1 - q^{-\frac{1}{2}} z_i)^{-1} \times \prod_i (1 - q^{-1} z_i^2) \prod_{i < j} (1 - q^{-1} z_i z_j^{-1})(1 - q^{-1} z_i z_j),$$

and the factor in front is interpreted as the p -part of a quadratic L-function. Letting $q \rightarrow 1$ the remaining product becomes the deformed Weyl denominator of type C . On the other hand, we may let $q^{-\frac{1}{2}} \rightarrow -1$, in which case (8) becomes the Weyl denominator of type B .

A similar dual interpretation pertains with the factor

$$\frac{1}{\Delta_C} \mathcal{A} \left(\mathbf{z}^{\lambda + \rho_C} \prod_{k=1}^r (1 - q^{-1/2} z_k^{-1}) \right). \quad (9)$$

On the one hand, if we expand the product we get a sum

$$\sum_{S \subset \{1, 2, 3, \dots, r\}} (-q^{1/2})^{|S|} \frac{1}{\Delta_C} \mathcal{A} \left(\mathbf{z}^{\lambda + \rho} \prod_{i \in S} z_i^{-1} \right). \quad (10)$$

Each term is either zero, or an irreducible character of $\mathrm{Sp}_{2r}(\mathbb{C})$ by the Weyl character formula. Hence (9) may be regarded as a sum of $\leq 2^r$ irreducible characters of $\mathrm{Sp}_{2r}(\mathbb{C})$ and thus has a Type C flavor. But on the other hand, let us again specialize $q^{\frac{1}{2}} \rightarrow -1$. Then using (7), the factor (9) becomes

$$\frac{1}{\Delta_B} \mathcal{A} (\mathbf{z}^{\lambda + \rho_B}) = \chi_\lambda^B(\mathbf{z}). \quad (11)$$

Actually this formula generalizes to a formula like (3) for the metaplectic Whittaker function in the form (9). We will discuss this point later.

Chinta-Gunnells description

Chinta and Gunnells [12], [13] gave a construction of the p -parts for multiple Dirichlet series. See also Chinta, Friedberg and Gunnells [11] and Chinta and Offen [10]. We will show that their construction gives the metaplectic Whittaker function of $\widetilde{\mathrm{Sp}}_{2r}(F)$ when the root system is of type B_r .

The Chinta-Gunnells method begins by defining an action on functions of the spectral parameters, which we review in the case at hand.

As before, let T be the maximal torus of diagonal elements in SO_{2r+1} , whose eigenvalues are $z_1, \dots, z_r, 1, z_r^{-1}, \dots, z_1^{-1}$. Let T' be the preimage of T in Spin_{2r+1} . The coordinate ring of T' is then generated by $z_i^{\pm 1}$ and by $\sqrt{z_1 \cdots z_r}$. We write a rational function f on T' as a linear combination of two parts f^+ and f^- , which are the odd and even parts respectively with respect to the rational map of T' that sends $z_i \rightarrow z_i$ and $\sqrt{z_1 \cdots z_r} \rightarrow -\sqrt{z_1 \cdots z_r}$. In the particular case at hand, the action is described separately on f^+ and f^- and it does not mix them. Thus we may describe the action separately in the two cases $f = f^+$ and $f = f^-$.

First suppose that $f = f^+$. Let s_1, \dots, s_r be the simple reflections in W . If $1 \leq i < r$ then

$$(f|s_i)(\mathbf{z}) = f(s_i \mathbf{z}),$$

while if $i = r$ then

$$(f|s_r)(\mathbf{z}) = \frac{1 - q^{-1/2} z_r^{-1}}{1 - q^{-1/2} z_r} f(s_r \mathbf{z}), \quad \mathbf{z} = (z_1, \dots, z_r).$$

If $f = f^-$ then the rule when $1 \leq i < r$ is unchanged but

$$(f|s_r)(\mathbf{z}) = \frac{1}{z_r} f(s_r \mathbf{z}).$$

The braid relations are satisfied, and so this definition extend to a right action $f \mapsto f|w$ for all $w \in W$. Now the Chinta-Gunnells description of the p -part of the multiple Dirichlet series may be written

$$\mathrm{CG}(\lambda, \mathbf{z}) = \mathbf{z}^{\lambda + \rho_C} \sum_{w \in W} \frac{\mathbf{z}^{-\lambda - \rho_C} |w}{\Delta_C(w \mathbf{z})}. \quad (12)$$

Let us denote this as $\mathrm{CG}(\lambda, \mathbf{z})$. Let

$$D(\mathbf{z}) = \prod_{i=1}^r (1 - q^{-1} z_i^2) \prod_{i < j} (1 - q^{-1} z_i z_j) (1 - q^{-1} z_i z_j^{-1}).$$

Theorem 2 *We have*

$$D(\mathbf{z}) \text{CG}(\lambda, \mathbf{z}) = \mathbf{z}^{\lambda+\rho_C} W(\lambda),$$

where $W(\lambda)$ is the Whittaker value defined in (6).

Proof Let

$$P = \prod_{i=1}^r (1 - q^{-1/2} z_i).$$

Lemma 1 *If $f = f^+$ then*

$$\frac{(f|w^{-1})(\mathbf{z})}{f(w\mathbf{z})} = \frac{P(w\mathbf{z})}{P(\mathbf{z})}.$$

Proof If $p(w, z) = P(w\mathbf{z})/P(\mathbf{z})$ then p satisfies the cocycle condition $p(ww', z) = p(w, w'z)p(w', z)$. The left-hand side also satisfies the same cocycle relation so we are reduced to the case where w is a simple reflection, in which case it follows easily from the definition. \square

Now $\text{CG}(\lambda, \mathbf{z})$ equals

$$\frac{\mathbf{z}^{\lambda+\rho_C}}{\Delta_C} \sum_{w \in W} (-1)^{l(w)} (\mathbf{z}^{-\lambda-\rho_C} | w) = \frac{\mathbf{z}^{\lambda+\rho_C}}{\Delta_C} \sum_{w \in W} (-1)^{l(w)} (\mathbf{z}^{-\lambda-\rho_C} | w).$$

Replacing w by w^{-1} and using the Lemma, this equals

$$\frac{\mathbf{z}^{\lambda+\rho_C}}{\Delta_C P(\mathbf{z})} \mathcal{A}(P(\mathbf{z}) \mathbf{z}^{-\lambda-\rho_C}).$$

Now we observe that for any function $\mathcal{A}(f(\mathbf{z})) = \mathcal{A}(f(w_0\mathbf{z}))$. We have $w_0\mathbf{z} = (z_1^{-1}, \dots, z_r^{-1})$ and so our last expression equals

$$\frac{\mathbf{z}^{\lambda+\rho_C}}{\prod_{i=1}^r (1 - q^{-1/2} z_i)} \frac{1}{\Delta_C} \mathcal{A} \left(\mathbf{z}^{\lambda+\rho_C} \prod_{i=1}^r (1 - q^{-1/2} z_i^{-1}) \right).$$

Multiplying by $D(\mathbf{z})$ and simplifying, the statement follows. \square

BZL Patterns

Let w_0 be the long Weyl group element. Choose a decomposition reduced decomposition $w_0 = s_{\omega_1} \cdots s_{\omega_N}$ into a product of simple reflections where $1 \leq \omega_i \leq r$ (the rank). Let

$$\omega = (\omega_1, \dots, \omega_N)$$

be the corresponding *reduced word* for w_0 .

Let $v \in \mathcal{B}$. Let k_1 be the largest integer such that $e_{\omega_1}^{k_1}(v) \neq 0$. Then let k_2 be the largest integer such that $e_{\omega_2}^{k_2} e_{\omega_1}^{k_1}(v) \neq 0$, and so forth. Then $e_{\omega_N}^{k_N} \cdots e_{\omega_1}^{k_1}(v) = v_\lambda$. The pattern (k_1, \dots, k_N) determines v , and gives a convenient way of parametrizing elements of the crystal. These patterns were studied by Littelmann [17] and by Berenstein and Zelevinsky [2]. We will refer to (k_1, \dots, k_N) as a *BZL pattern* and write $(k_1, \dots, k_N) = \text{BZL}_\omega(v)$.

Theorem 3 *There exists a unique function σ on \mathcal{B} taking values in the nonnegative integers with the following properties. If v_λ is the highest weight vector then $\sigma(v_\lambda) = 0$. If $x, y \in \mathcal{B}$ and $f_i(x) = y$ with $i < r$, then $\sigma(x) = \sigma(y)$. If $e_r(x) = 0$, and $y = f_r^k(x)$, then*

$$\sigma(y) = \begin{cases} \sigma(x) & \text{if } k \text{ is even,} \\ \sigma(x) + 1 & \text{if } k \text{ is odd.} \end{cases}$$

Let us illustrate this with an example.

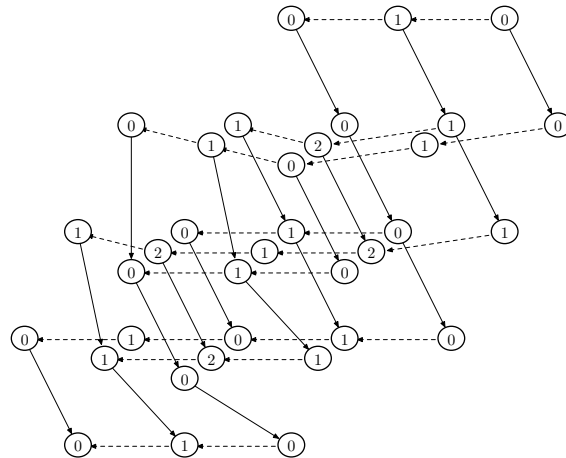

This illustrates the crystal with highest weight $\lambda = (2, 1)$ for B_2 . We draw $x \longrightarrow y$ with a solid arrow if $y = f_1(x)$, and with a dashed arrow if $y = f_2(x)$. The vertex in the upper right-hand corner is v_λ . The values of σ are shown for every element.

Proof We will give one definition of σ for each reduced decomposition

$$w_0 = s_{\omega_1} s_{\omega_2} \cdots s_{\omega_{r,2}}$$

of the long element. We will show that these definitions are all equivalent, then deduce the statement. We start with the BZL string of $v \in \mathcal{B}$ corresponding to this word. Thus if

$$\omega = (\omega_1, \omega_2, \cdots, \omega_{r,2})$$

let $k_1, k_2, \cdots, k_{r,2}$ be defined by

$$e_{\omega_n}^{k_n} \cdots e_{\omega_1}^{k_1} v \neq 0, \quad e_{\omega_n}^{k_n+1} \cdots e_{\omega_1}^{k_1} v \neq 0,$$

so that $e_{\omega_{r,2}}^{k_{r,2}} \cdots e_{\omega_1}^{k_1} v = v_\lambda$ is the highest weight element of the crystal base. Define

$$\sigma_\omega(v) = \sum_{\omega_j=r} \begin{cases} 1 & \text{if } k_j \text{ is odd,} \\ 0 & \text{if } k_j \text{ is even.} \end{cases} \quad (13)$$

We wish to assert that if σ and $\sigma' = (\omega'_1, \cdots, \omega'_{r,2})$ are two reduced decompositions then $\phi_\sigma = \phi_{\sigma'}$.

The proof will involve a reduction to the rank two case, so let us first prove that the statement is true for crystals of type B_2 . In this case, there are only two reduced words and we may assume that $\omega = \{1, 2, 1, 2\}$ and $\omega' = \{2, 1, 2, 1\}$. In this case, Littelmann [17] (Section 2) proved that

$$\begin{aligned} k'_1 &= \max(k_4, k_3 - k_2, k_2 - k_1), \\ k'_2 &= \max(k_3, k_1 - 2k_2 + 2k_3, k_1 + 2k_4), \\ k'_3 &= \min(k_2, 2k_1 - k_3 + k_4, k_4 + k_1), \\ k'_4 &= \min(k_1, 2k_2 - k_3, k_3 - 2k_4). \end{aligned}$$

From this it follows easily that the number of odd elements of the set $\{k'_2, k'_4\}$ is the same as the number of odd elements of the set $\{k_1, k_3\}$, that is, $\sigma_\omega = \sigma_{\omega'}$.

We turn now to the proof that $\sigma_\omega = \sigma_{\omega'}$ when r is general. Let Σ be the set of all reduced words representing the long element, and consider the equivalence relation generated by $\omega \sim \omega'$ if ω' is obtained from ω by replacing a string $\{l, m, l, m, \cdots\}$ of length equal to the order N of $s_l s_m$ in the Weyl group by the string $\{m, l, m, l, \cdots\}$ of the same length. By a theorem of Tits any two reduced decompositions are equivalent under this relation. As a consequence, it is sufficient to show that $\sigma_\omega = \sigma_{\omega'}$ when σ' is obtained by replacing an occurrence of l, m, l by m, l, m ($m = l + 1 < r$), or an

occurrence of l, m, l, m by m, l, m, l ($l = r - 1, m = r$) or an occurrence of l, m by m, l when $|l - m| > 1$.

Suppose that $i_t = l, i_{t+1} = m$, etc. are the elements of σ that are changed in σ' . The element i_{t-1} and i'_{t-1} of σ and σ' preceding this string (if it is not initial) is not l or m , and similarly the element following it. Let

$$v_h = e_{i_h}^{k_h} \cdots e_{i_1}^{k_1} v, \quad e_{i_h}^{k_h+1} \cdots e_{i_1}^{k_1} v = 0, \quad v'_h = e_{i'_h}^{k'_h} \cdots e_{i'_1}^{k'_1} v, \quad e_{i'_h}^{k'_h+1} \cdots e_{i'_1}^{k'_1} v = 0,$$

so $v_0 = v'_0 = v$ and $v_{r^2} = v'_{r^2} = v_\lambda$. We will argue that the sequences v_0, v_2, \dots, v_{r^2} and $v'_0, v'_2, \dots, v'_{r^2}$ are the same, as are the sequences k_1, k_2, \dots, k_{r^2} and $k'_1, k'_2, \dots, k'_{r^2}$, except that in the middle of the sequences, $v_{t-1} = v'_{t-1}$ and $v_{t+N-1} = v'_{t+N-1}$ but $v_t, v_{t+1}, \dots, v_{t+N-2}$ are replaced by their primed counterparts, and similarly the k_i .

To see this, remove all edges of the crystal graph except those labeled l and m produces a crystal graph \mathcal{B}' of type $A_2, B_2, A_1 \times A_1$ or $A_1 \times B_1$. Then $v_{t-1} = v'_{t-1}$ since ω and ω' agree up to this point. Let \mathcal{B}'' be the connected component of \mathcal{B}' containing this. Then v_{t+N-1} is the highest weight vector in \mathcal{B}'' and so is v'_{t+N-1} . It is now clear that the portion of the BZL pattern which lies within this crystal is the only part of k_1, \dots, k_{r^2} which is different from k'_1, \dots, k'_{r^2} , and we have only to show that the number of k_i within this subpattern with $\omega_i = r$ such that k_i is odd is the same as for the k'_i . That is, we have reduced to the rank two case. If \mathcal{B}' is of type B_2 we have proven this, and the other three cases are trivial, since an A_2 or $A_1 \times A_1$ crystal has no edges of type r , while an $A_1 \times B_1$ crystal is just a Cartesian product.

Now let $1 \leq i \leq r$. To verify the assertion that if $f_i(x) = y$, choose a word ω whose first element $\omega_1 = i$. If $(k_1, \dots, k_{r^2}) = \text{BLZ}_\omega(x)$ then $(k_1 + 1, k_2, \dots, k_{r^2}) = \text{BZL}_\omega(y)$. Thus Since $\sigma(x)$ is the number of odd k_i with $\omega_i = r$, it is obvious that $\sigma(x) = y$. On the other hand, suppose that $e_r(x) = 0$. Choosing ω such that $\omega_1 = r$, we have $\text{BZL}(x) = (k_1, \dots, k_{r^2})$ with $k_1 = 0$ while $\text{BZL}(f_r^k(x)) = (k, k_2, \dots, k_{r^2})$ and so obviously $\sigma(f_r^k(x)) = \sigma(x)$ if k is odd and $\sigma(x) + 1$ if k is even. \square

We recall that the Weyl group acts on the crystal: each simple reflection s_i acts by reversing the i -root strings. It is shown that this action gives rise to a well-defined action on the crystal in Littelmann [18].

Proposition 1 *If λ is integral, then the function σ is constant on W orbits of the crystal.*

Proof It is clear from the definition that reversing the i -root string through $v \in \mathcal{B}_\lambda$ does not change $\sigma(v)$ if $i < r$ since σ is constant on the root string in that case. If $i = r$, then the fact that λ is integral means that each root string has odd length,

and therefore $\sigma(s_i(v)) = \sigma(v)$ in this case also, since $v - s_r(v) = k\alpha_r$ with k even. If λ is half-integral, the Weyl group action does not preserve σ . \square

Conjecture 1 *Assume that λ is integral. Then*

$$\frac{1}{\Delta_C} \mathcal{A} \left(\mathbf{z}^{\lambda + \rho_C} \prod_{k=1}^r (1 - q^{-1/2} \mathbf{z}_i^{-1}) \right) = \sum_{v \in \mathcal{B}_\lambda} (-q^{1/2})^{\sigma(v)} \mathbf{z}^{\text{wt}(v)}.$$

This expresses the metaplectic Whittaker function (except for its normalizing constant) as a sum over the crystal.

Type B crystals

Let \mathcal{B} be the crystal of an irreducible finite-dimensional representation for any Cartan type, and let W be the corresponding Weyl group. We will denote the Kashiwara (root) operators by e_i and f_i . They are maps $\mathcal{B} \rightarrow \mathcal{B} \cup \{0\}$. If λ is the highest weight then there is a unique element $v_\lambda \in \mathcal{B}$ of weight λ .

Let us disregard the normalizing constant (8) for the time being, and consider (9) to be the value of the p -adic Whittaker function at t_λ in $\widetilde{\text{Sp}}_{2r}(F)$, where λ is a dominant weight for $\text{Spin}_{2r+1}(\mathbb{C})$. Strictly speaking, this only makes sense if λ is integral. However if λ is half-integral, it is probable that this scenario can be extended, taking t_λ in $\text{GSp}_{2r}(F)$. In any case, (9) is defined whether λ is integral or half-integral.

We saw in (11) that when $q^{1/2}$ is specialized to -1 the value of (9) becomes the character χ_λ^B of an irreducible representation of $\text{Spin}_{2r+1}(\mathbb{C})$. We will reinterpret this fact in terms of crystals, showing that for any q , the expression (9) may be interpreted as a deformation of χ_λ^B .

Decorated BZL Patterns

We will decorate the values k_1, \dots, k_N by drawing boxes or circles around some of them, by rules that we will explain. The boxing rule is as follows. If

$$f_{\omega_i} e_{\omega_{i-1}} \dots e_{\omega_1}(v) = 0$$

then we box k_i . Concretely, this means that the path from v to v_λ that goes through

$$v, e_{\omega_1}^{k_1}(v), e_{\omega_2}^{k_2} e_{\omega_1}^{k_1}, \dots$$

includes the entire ω_i -string through $e_{\omega_i}^{k_i} \cdots e_{\omega_1}^{k_1}(v)$. Intuitively, it means (very roughly) that the value k_i is as large as possible, and cannot be increased.

The circling rule may be expressed also very roughly as meaning that the value k_i is as small as possible, and cannot be decreased. To make this precise for type B_r and for one particular reduced word ω , we appeal to some results of Littelmann.

The admissible BZL patterns of type B_r (and other Cartan types) are described in Littelmann [17]. We will use the Bourbaki ordering of the weights, so that the fundamental dominant weights are $\omega_1, \dots, \omega_r$ with $\omega_1 = (1, 0, \dots, 0)$ the highest weight of the standard representation, and $\omega_r = (\frac{1}{2}, \dots, \frac{1}{2})$ the highest weight of the spin representation. Then the reduced decomposition that we will use is

$$w_0 = s_r(s_{r-1}s_r s_{r-1})(s_{r-2}s_{r-1}s_r s_{r-1}s_{r-2}) \cdots (s_1 \cdots s_r \cdots s_1).$$

Thus $\omega = (r, r-1, r, r-1, r-2, r-1, r, r-1, r-2, \dots)$ and $N = r^2$. An alternative indexing will sometimes be convenient, so we will write alternatively

$$\text{BZL}(v) = (k_1, \dots, k_{r^2}) = (k_{r,r}, k_{r-1,r-1}, k_{r-1,r}, k_{r-1,r+1}, \dots).$$

Following Littelmann, we put the entries into a triangular array, from bottom to top and left to right, thus

$$\left\{ \begin{array}{cccccc} k_{1,1} & \cdots & & k_{1,r} & k_{1,r+1} & \cdots & k_{1,2r-1} \\ & \ddots & & \vdots & & \ddots & \\ & & k_{r-1,r-1} & k_{r-1,r} & k_{r-1,r+1} & & \\ & & & k_{r,r} & & & \end{array} \right\} = \left\{ \begin{array}{cccccc} \cdots & & \vdots & & \cdots & & \\ & k_5 & k_6 & k_7 & k_8 & k_9 & \\ & & k_2 & k_3 & k_4 & & \\ & & & k_1 & & & \end{array} \right\}$$

Littelmann proved that the entries in each row satisfy the following inequalities:

$$2k_{i,i} \geq 2k_{i,j+1} \geq \cdots \geq 2k_{i,r-1} \geq k_{i,r} \geq 2k_{i,r+1} \geq \cdots \geq 2k_{i,2r-i} \geq 0$$

Note that every value is doubled except the middle one.

Let us describe the rules for this. First, we circle the entry if the corresponding inequality is strict. Let us make this explicit in the case $r = 3$. In this case

$$\text{BZK}(v) = (k_{3,3}, k_{2,2}, k_{2,3}, k_{2,4}, k_{1,1}, k_{1,2}, k_{1,3}, k_{1,4}, k_{1,5}) = (k_1, k_2, \dots, k_9)$$

and the array is:

$$\left\{ \begin{array}{ccccc} k_{1,1} & k_{1,2} & k_{1,3} & k_{1,4} & k_{1,5} \\ & k_{2,2} & k_{2,3} & k_{2,4} & \\ & & k_{3,3} & & \end{array} \right\} = \left\{ \begin{array}{ccccc} k_5 & k_6 & k_7 & k_8 & k_9 \\ & k_2 & k_3 & k_4 & \\ & & k_1 & & \end{array} \right\}. \quad (14)$$

We have

$$k_{3,3} \geq 0$$

and if $k_{3,3} = 0$ we circle it. We have $2k_{2,2} \geq k_{2,3}$ and if this is an equality, we circle $k_{2,2}$. Similarly $k_{2,3} \geq 2k_{2,3}$ and if this is equality, we circle $k_{2,3}$.

We attach a simple root of the B_r root system to each column of the array, in this order:

$$\alpha_1, \dots, \alpha_{r-1}, \alpha_r, \alpha_{r-1}, \dots, \alpha_r.$$

Thus if

an entry is in the column labeled by α_i , then the corresponding element of the long word ω is i . Thus let c_i be the sum of the i -th column. We have

$$\text{wt}(v) = \lambda - (c_1 + c_{2r-1})\alpha_1 - (c_2 + c_{2r-1})\alpha_2 - \dots - c_r\alpha_r.$$

Only α_r is a short root.

The Sum

Let p be a prime element in the nonarchimedean local field F . Let $(,)$ be the local Hilbert symbol. If $0 \neq c \in \mathfrak{o}$ and $m \in \mathfrak{o}$

$$g_t(m, c) = \sum_{\substack{x \bmod c \\ \gcd(x, c) = 1}} \psi\left(\frac{mx}{c}\right) (x, c)^t.$$

We will need these for $t = 1, 2$. We will also denote, for a nonnegative integer a

$$g_t(a) = g_t(p^{a-1}, p^a), \quad h_t(a) = g_t(p^a, p^a).$$

If $n = 2$, then all these Gauss sums may be made explicit. The Gauss sum $g_1(1, p)$ is a square root of q , which we will denote $q^{1/2}$; by choosing ψ correctly we may arrange that it is the positive square root. Assuming $n = 2$, we then have:

$$g_1(a) = q^{a-\frac{1}{2}}, \quad h_1(a) = \begin{cases} q^{a-1}(q-1) & \text{if } a \text{ is even,} \\ 0 & \text{otherwise,} \end{cases}$$

and

$$g_2(a) = -q^{a-1}, \quad h_2(a) = (q-1)q^{a-1}.$$

We now assume that n is even, and that \mathcal{B} is crystal of type B_r . If $v \in \mathcal{B}$ we define

$$G(v) = \prod_{k \in \text{BZL}(v)} \begin{cases} q^{-k} h_t(k) & \text{if } k \text{ is unboxed and uncircled,} \\ q^{-k} g_t(k) & \text{if } k \text{ is boxed but not circled,} \\ 1 & \text{if } k \text{ is circled but not boxed,} \\ 0 & \text{if } k \text{ is both boxed and circled.} \end{cases}$$

where $t = t(k)$ is 1 if the root corresponding to k is α_r , and $t = 2$ otherwise. This means that $t = 1$ if k is in the middle column of the array (14), and $t = 2$ otherwise. Note that these differ from the weights used in [4] in two ways:

- Due to the presence of both long and short roots we have two kinds of Gauss sums, indexed by t .
- The factor is multiplied by q^{-k} which ultimately simplifies the formulas.
- We have made our BZL patterns using the e_i instead of the f_i . This makes no real difference.

Now let λ be a dominant weight. Then we claim that $G(v)$ is a Tokuyama function for the metaplectic Whittaker function. More precisely:

Conjecture 2 *Assume that λ is integral. Then with $W(\lambda)$ as in (6), we have*

$$W(\lambda) = \sum_{v \in \mathcal{B}_{\lambda+\rho}} G(v) z^{-\text{wt}(v)}$$

Ice Models

We will now give an alternative description of the Whittaker function as the partition function of a statistical system in the six-vertex model. The Boltzmann weights are in the free-fermionic regime studied by Brubaker, Bump and Friedberg [3]. This particular system is closely related to one studied by Hamel and King [14] and Ivanov [15]. It is also similar to the U-turn models used by Kuperberg [16] to study a class of alternating sign matrices. Despite these similarities, the particular model that we describe is new.

Some arguments in this section are very similar to those in Ivanov [15]. The model that we consider is very similar to the one that he uses, except that the Boltzmann weights at the ‘‘caps’’ to be introduced below are different in his work.

We consider an array of vertices with $2r$ rows and sufficiently many columns. The intersections of the rows and columns of the array will be called *vertices*. The

vertices in the odd numbered rows will be designated “Gamma ice” (labeled \bullet) and those in even numbered rows (labeled \circ) will be designated “Delta ice.” Each pair of rows will be closed at the right edge by a “cap” containing a single vertex. Thus if $r = 2$ the array looks like:

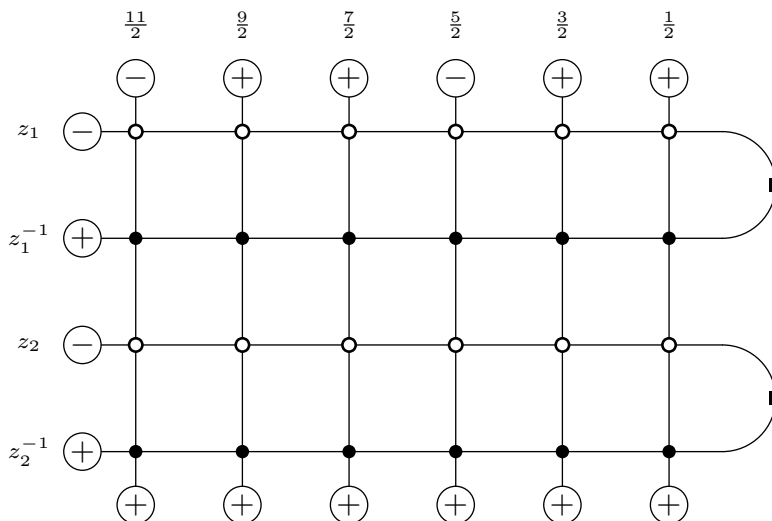

We have labeled the boundary edges by certain signs \pm . The interior edges will also be labeled with signs, but these signs will be variable, whereas the boundary edge signs are fixed and are part of the data describing the system.

The boundary edge signs are to be described as follows. We put $-, +, -, +, \dots$ on the left edge, so that the rows of Delta ice begin with $-$ and the rows of Gamma ice begin with $+$. We put $+$ along the bottom edge. For the top edge, we label the columns with half integers beginning with $\frac{1}{2}$ at the right and increasing by 1 from right to left. We put $-$ in the columns labeled from values in $\lambda + \rho_B$. Thus if $r = 2$ and $\lambda = (4, 2)$ then $\lambda + \rho_B = (\frac{11}{2}, \frac{5}{2})$ and so we put $-$ in those columns, as indicated. The remaining top edges are labeled $+$.

A *state* of the system is an assignment of edges to the remaining interior edges. For the Gamma and Delta vertices, the assignments must be taken from the following

choices.

Γ vertex						
Boltzmann weight	1	z_i^{-1}	t	z_i^{-1}	$z_i^{-1}(t+1)$	1
Δ vertex						
Boltzmann weight	z_i	$z_i(t+1)$	1	$z_i t$	1	1

For the cap vertices, which we will label \square , the two adjacent edges must have the same sign, as follows.

\square Cap Vertex		
Boltzmann weight	$-\sqrt{-t}z_i^{1/2}$	$z_i^{-1/2}$

Let t be a parameter to be determined later. Every vertex in the state has a *Boltzmann weight* taken from the above table. Let $\mathfrak{S} = \mathfrak{S}(z_1, \dots, z_r, t)$ be the set of all states.

Given a state $S \in \mathfrak{S}$ of the system, the Boltzmann weight $\text{BW}(S)$ of the state is the product over all vertices of the weights of the vertex. The *partition function* $Z(\mathfrak{S})$ is the sum over all states S of $\text{BW}(S)$.

The Weyl group W is the group of transformations of z_1, \dots, z_r generated by permutations of the z_i and the 2^r transformations $z_i \rightarrow z_i^{\pm 1}$.

Proposition 2 *The product*

$$z^{\rho_B} \prod_i (1 - i\sqrt{t}z_i^{-1}) \left[\prod_{i>j} (1 + tz_i z_j)(1 + tz_i z_j^{-1}) \right] Z(\mathfrak{S}) \quad (15)$$

is invariant under the action of W .

The ideas of this proof are similar to those in [3], where the “caduceus” braid also appears.

Proof We must show invariance under the simple reflections. First we check invariance when z_i and z_{i+1} are switched.

We make use of the following types of vertices.

Type							
$\Gamma\Delta$							
Boltzmann weight	$t^2 z_j - z_i^{-1}$	$(t+1)z_j$	$tz_j + z_i^{-1}$	$tz_j + z_i^{-1}$	$(t+1)z_i^{-1}$	$z_i^{-1} - z_j$	
$\Delta\Delta$							
Boltzmann weight	$tz_i + z_j$	$z_j(t+1)$	$tz_j - tz_i$	$z_i - z_j$	$(t+1)z_i$	$z_i + tz_j$	
$\Gamma\Gamma$							
Boltzmann weight	$tz_i^{-1} + z_j^{-1}$	$tz_j^{-1} + z_i^{-1}$	$tz_j^{-1} - tz_i^{-1}$	$z_i^{-1} - z_j^{-1}$	$(t+1)z_i^{-1}$	$(t+1)z_j^{-1}$	
$\Delta\Gamma$							
Boltzmann weight	$z_i - z_j^{-1}$	$(t+1)z_i$	$tz_i + z_j^{-1}$	$tz_i + z_j^{-1}$	$(t+1)z_j^{-1}$	$-t^2 z_i + z_j^{-1}$	

The results in [3] include the following “star-triangle relation” or Yang-Baxter equation. Let $X, Y \in \{\Gamma, \Delta\}$. Choose three vertices of types X, Y and XY , whose Boltzmann weights are given by the above tables. Call these vertices S, T and R . Let $\varepsilon_1, \dots, \varepsilon_6$ be six signs, \pm . Then the following two partition functions (each involving

two vertices) are equal.

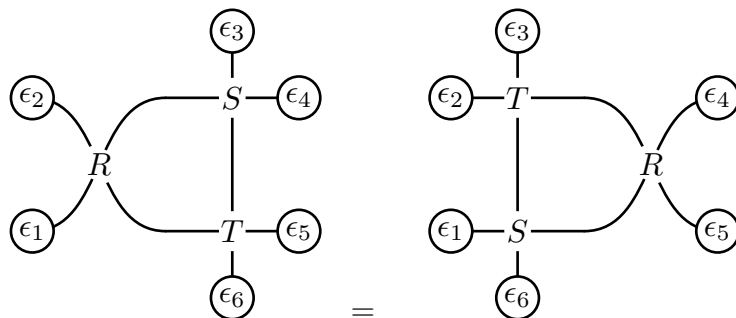

This means that (on each side of the equation) we sum over all assignments of signs to the 3 interior edges, which are marked with unlabeled circles. The reversal of the spectral parameters, and of the order of the S and T vertices is indicated.

Now consider four rows of the system, which have (alternately) Δ , Γ , Δ , Γ vertices, with spectral parameters z_i , z_i^{-1} , z_j and z_j^{-1} . (So $j = i + 1$.) To the left of these four rows, we attach the following “caduceus” braid, which was first considered by Ivanov [15].

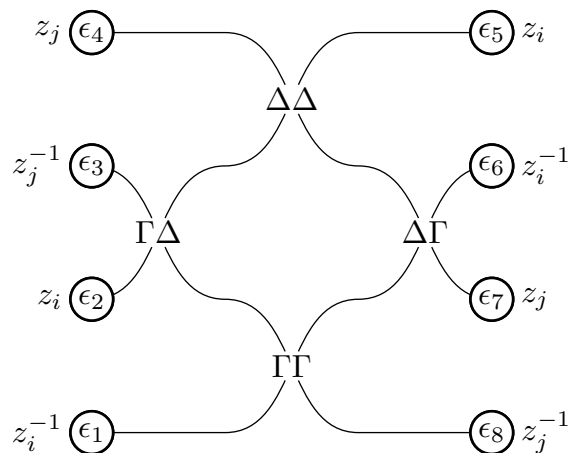

We observe that there is only one legal configuration for this system which has

$(\varepsilon_1, \varepsilon_2, \varepsilon_3, \varepsilon_4) = (+, -, +, -)$. This configuration is:

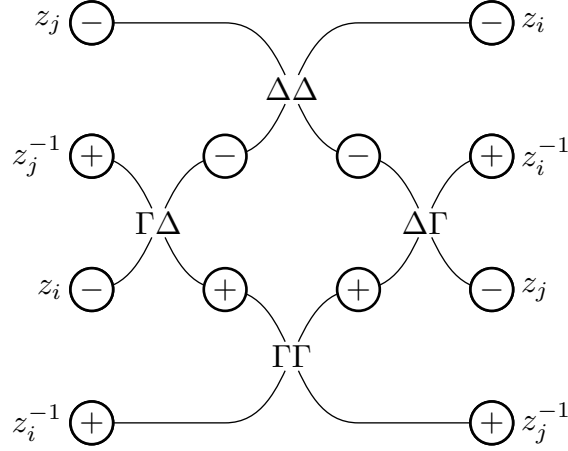

The partition function is just the product of the values at the four vertices, which can be read off from the above table:

$$(tz_j + z_i^{-1})(z_i + tz_j)(tz_i^{-1} + z_j^{-1})(tz_i + z_j^{-1}). \quad (16)$$

Therefore attaching the caduceus to the left of the four rows multiplies the partition function by this factor.

Using the Yang-Baxter equation, the factor moves across the ice until it encounters the caps. In the process, the z_i and z_j spectral parameters are interchanged – effectively the two pairs of rows are switched.

Lemma 2 *Let $\varepsilon_1, \varepsilon_2, \varepsilon_3, \varepsilon_4 \in \{+, -\}$. Then the partition function of the system on the left in the following diagram*

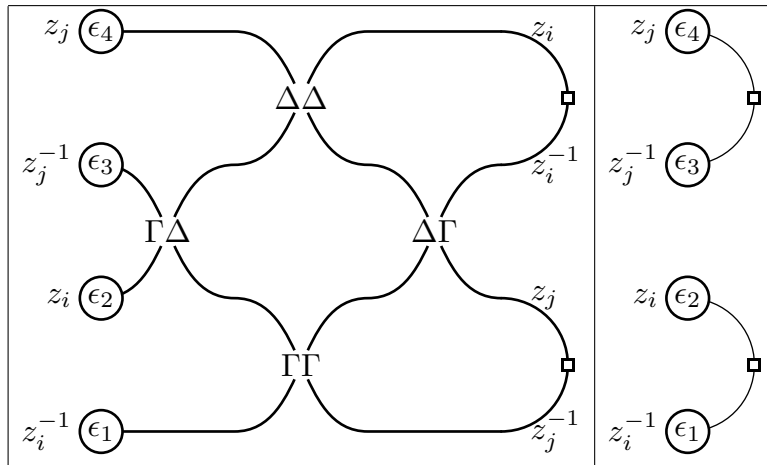

equals

$$(tz_i + z_j^{-1})(tz_i + z_j)(tz_i^{-1} + z_j^{-1})(tz_j + z_i^{-1}). \quad (17)$$

times the partition function of the system on the right.

This means that interchanging z_i and $z_j = z_{i+1}$ has the effect of multiplying Z by the ratio of (16) to (17). This ratio equals

$$\frac{z_j + tz_i}{z_i + tz_j} = \frac{z_j}{z_i} \cdot \frac{1 - tz_i z_j^{-1}}{1 - tz_j z_i^{-1}} = \frac{z^{s_i \rho_B} 1 - tz_i z_j^{-1}}{z^{\rho_B} 1 - tz_j z_i^{-1}},$$

which means that the product (15) is invariant under this interchange.

Now we consider the effect of the interchange $z_r \leftrightarrow z_r^{-1}$. For this, we begin by transforming the very bottom row of Γ vertices with spectral parameters z_r into Δ vertices with the spectral parameter z_r^{-1} by changing the signs of all the horizontal edges in the row. Thus we are using the following weights before and after the change:

Γ vertex (before)						
Boltzmann weight	1	z_r^{-1}	1	z_r^{-1}	t	$z_r^{-1}(t+1)$
Δ vertex (after)						
Boltzmann weight	1	z_r^{-1}	1	$z_r^{-1}t$	1	$z_r^{-1}(t+1)$

This change has no effect on the Boltzmann weights because of the boundary conditions: only $+$ occur in the bottom edge spins, and therefore only the first three patterns occur. In order to compensate for the change, we must replace the cap vertices with the following modified ones, which we label by \blacksquare instead of \square :

\blacksquare Cap Vertex		
Boltzmann weight	$-\sqrt{-t}z_r^{1/2}$	$z_r^{-1/2}$

Now we attach a $\Delta\Delta$ vertex to the left, using the following Boltzmann weights:

$\Delta\Delta$						
Boltzmann weight	$tz_r + z_r^{-1}$	$z_r^{-1}(t + 1)$	$tz_r^{-1} - tz_r$	$z_r - z_r^{-1}$	$(t + 1)z_r$	$z_r + tz_r^{-1}$

We are putting $-$ on both left edge vertices. This multiplies the partition function by $z_r + tz_r^{-1}$. We use the Yang-Baxter equation repeatedly to push this $\Delta\Delta$ vertex across the bottom two rows until it encounters the cap. Then we have the following configuration:

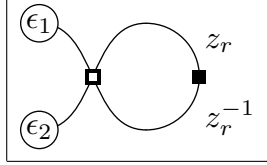

It may be checked that the value of this configuration is

$$(1 - \sqrt{-tz_r})(1 + \sqrt{-tz_r^{-1}})$$

times the value of the single \blacksquare vertex. After this is substituted we may then repeat the sign change, turning the bottom row back into Γ vertices, with parameter z_r^{-1} changed to z_r .

Therefore $z_r + tz_r^{-1}$ times $Z(\mathfrak{S})$ equals $(1 - \sqrt{-tz_r})(1 + \sqrt{-tz_r^{-1}})$ times the partition function with z_r replaced by its inverse. This implies that (15) is invariant under $z_r \rightarrow z_r^{-1}$. \square

Conjecture 3 Take $t = -\frac{1}{q}$. Then $Z(\mathfrak{S})$ equals

$$z^{w(\rho_B)} \prod_i (1 + q^{-1/2} z_i) \left[\prod_{i < j} (1 - q^{-1} z_i z_j) (1 - q^{-1} z_i z_j^{-1}) \right] \frac{1}{\Delta_C} \mathcal{A} \left(z^{\lambda + \rho_C} \prod_{k=1}^r (1 - q^{-1/2} z_k^{-1}) \right)$$

It follows from Proposition 2 that $Z(\mathfrak{S})$ is divisible by the product

$$\prod_i (1 + q^{-1/2} z_i) \left[\prod_{i < j} (1 - q^{-1} z_i z_j) (1 - q^{-1} z_i z_j^{-1}) \right],$$

and the quotient is a polynomial in $q^{-1/2}$ and z_i, z_i^{-1} that is invariant under the Weyl group. We can prove the conjecture if $r \leq 3$.

Thus, this ice-type model conjecturally represents the Whittaker function. This conjecture implies Conjecture 2.

References

- [1] J. Beineke, B. Brubaker, and S. Frechette. A crystal definition for symplectic multiple Dirichlet series. In *This Volume*.
- [2] A. Berenstein and A. Zelevinsky. String bases for quantum groups of type A_r . In *I. M. Gelfand Seminar*, volume 16 of *Adv. Soviet Math.*, pages 51–89. Amer. Math. Soc., Providence, RI, 1993.
- [3] B. Brubaker, D. Bump, and S. Friedberg. Schur polynomials and the Yang-Baxter equation. *Preprint*, 2010.
- [4] B. Brubaker, D. Bump, and S. Friedberg. *Weyl Group Multiple Dirichlet Series: Type A Combinatorial Theory*. Annals of Mathematics Studies, to appear.
- [5] B. Brubaker, D. Bump, S. Friedberg, and J. Hoffstein. Weyl group multiple Dirichlet series III: Eisenstein series and twisted unstable A_r . *Annals of Mathematics*, 166:293–316, 2007.
- [6] Ben Brubaker, Daniel Bump, and Solomon Friedberg. Gauss sum combinatorics and metaplectic Eisenstein series. In *Automorphic forms and L-functions I. Global aspects*, volume 488 of *Contemp. Math.*, pages 61–81. Amer. Math. Soc., Providence, RI, 2009.
- [7] Daniel Bump, Solomon Friedberg, and Jeffrey Hoffstein. p -adic Whittaker functions on the metaplectic group. *Duke Math. J.*, 63(2):379–397, 1991.
- [8] W. Casselman and J. Shalika. The unramified principal series of p -adic groups. II. The Whittaker function. *Compositio Math.*, 41(2):207–231, 1980.
- [9] G. Chinta and P. Gunnells. Littelmann patterns and Weyl group multiple Dirichlet series of type D. In *This Volume*.
- [10] G. Chinta and O. Offen. A metaplectic Casselman-Shalika formula for GL_r . *Preprint*, 2009.

- [11] Gautam Chinta, Solomon Friedberg, and Paul E. Gunnells. On the p -parts of quadratic Weyl group multiple Dirichlet series. *J. Reine Angew. Math.*, 623:1–23, 2008.
- [12] Gautam Chinta and Paul E. Gunnells. Weyl group multiple Dirichlet series constructed from quadratic characters. *Invent. Math.*, 167(2):327–353, 2007.
- [13] Gautam Chinta and Paul E. Gunnells. Constructing Weyl group multiple Dirichlet series. *J. Amer. Math. Soc.*, 23(1):189–215, 2010.
- [14] A. M. Hamel and R. C. King. Bijective proofs of shifted tableau and alternating sign matrix identities. *J. Algebraic Combin.*, 25(4):417–458, 2007.
- [15] Ivanov. Dissertation. *Stanford*, 2010.
- [16] Greg Kuperberg. Symmetry classes of alternating-sign matrices under one roof. *Ann. of Math. (2)*, 156(3):835–866, 2002.
- [17] P. Littelmann. Cones, crystals, and patterns. *Transform. Groups*, 3(2):145–179, 1998.
- [18] Peter Littelmann. Paths and root operators in representation theory. *Ann. of Math. (2)*, 142(3):499–525, 1995.
- [19] H. Matsumoto. Sur les sous-groupes arithmétiques des groupes semi-simples déployés. *Ann. Sci. École Norm. Sup. (4)*, 2:1–62, 1969.
- [20] Gordan Savin. Local Shimura correspondence. *Math. Ann.*, 280(2):185–190, 1988.
- [21] T. Tokuyama. A generating function of strict Gelfand patterns and some formulas on characters of general linear groups. *J. Math. Soc. Japan*, 40(4):671–685, 1988.