

Other Test Method 37 (OTM-37): Measurement of Direct PM_{2.5} and PM₁₀ Emissions at Low Concentrations by Dilution Sampling (Constant Sampling Rate Procedure)

Note: Please submit a copy, either electronic or paper, of any test report from application of this OTM to EPA's Measurement Technology Group.

- Electronic copies should be submitted via email with the subject line "OTM-037" to: EMC@epa.gov
- Paper copies should be mailed to:

**Measurement Technology Group
Office of Air Quality Planning and Standards
U.S. Environmental Protection Agency (Mail Code E143-02)
Research Triangle Park, NC 27711**

Background on OTM-37

EPA promulgated a revised constant rate sampling procedure (40 CFR 51, Appendix M, Method 201A) to measure filterable PM₁₀ and PM_{2.5} at stationary sources (75 FR 80118, December 21, 2010), which includes a PM_{2.5} cyclone (IV) between a PM₁₀ cyclone (I) and an in-stack filter. EPA promulgated a revised sampling procedure (40 CFR 51, Appendix M, Method 202) to measure condensable particulate matter at stationary sources (*ibid.*). Prior to promulgation of revised Methods 201A and 202 in 2010, in 2004 EPA published Conditional Test Method 039 (CTM-039) to measure filterable and condensable PM₁₀ and PM_{2.5} at stationary sources using a dilution sampling technique (see reference 9 in Section 16 of this method).

CTM-039 serves as a valuable foundation for this new low concentration primary (direct) PM₁₀ and PM_{2.5} test method, OTM-37, which shares many of the same equipment, elements and language. ISO Method 25597:2013 (see reference 6 in section 16 of this method) also serves as a foundation for certain calculations in this method. ISO Method 25597:13 specifies calculations for a stationary source PM₁₀ and PM_{2.5} partial flow dilution sampling method whereby a portion of the diluted stack gas sample is drawn through a filter and the remainder of the diluted stack gas sample is bypassed. In addition, because this method cools and dilutes the stack gas sample to near ambient conditions, aliquots of the bypassed diluted sample gas could be collected for analyses using ambient air methodologies. The ambient air sample collection and analysis methods and procedures given in 40 CFR 50, Appendix L provide an important foundation for the procedures specified in this method.

This method for measurement of primary PM

OTM-37 includes additional modification of specifications for CTM-039 equipment to improve accuracy and precision at low concentrations, including:

- Addition of one or more 38 mm (1.5 inch) diameter sanitary flange fittings to the 142 mm exhaust filter holder inlet to accommodate 47 mm PTFE membrane sample filters for sample collection;
- Addition of a 38 mm (1.5 inch) sanitary flange fitting in the dilution air supply line to accommodate a 47 mm PTFE membrane filter for dilution air blanks; and
- Addition of mass flow meters (MFM) for measuring diluted sample flow rate through the 47 mm filters;
- Electropolishing of rather than applying PTFE coating on electrically conductive metal surfaces in contact with the diluted sample to minimize particle deposits on the surfaces due to electrostatic charge.

The calculation setup in this method and Method 201A (2010) are similar, with additional calculations in OTM-37 for:

- Dilution system setup;
- Use of venturis for measuring raw (undiluted) sample and dilution air flow rates;
- Use of diluted sample and dilution air relative humidities for calculating sample moisture fraction;
- Use of mass flow meters (MFM) for measuring diluted sample and dilution air flow rates through the 47 mm filters; and
- Bypassing a portion of the diluted sample stream through the exhaust filter.

It also must be noted that due to the complexity of the calculations, computer software in conjunction with a data acquisition system should be used to monitor, calculate, and record all the pertinent data and parameters necessary to operate and use this method. Method performance data using similar methodology are available for clean gas (natural gas or refinery fuel gas) fired boilers, process heaters, gas turbine engines and combined cycle/ cogeneration units, and reciprocating engines. Similar approaches have also been applied to a No. 6 oil-fired boiler and a diesel engine (with and without diesel particulate filter). See Section 13 of this method for additional discussion of method performance and Section 16 for the cited references.

This method was submitted by Ramboll Environ, Inc. in conjunction with the American Petroleum Industry (API) to EPA's Office of Air Quality, Planning and Standards – Air Quality Assessment Division – Measurement Technology Group (MTG) for inclusion into the Other Test Method (OTM) category on EPA's Air Emission Monitoring Center (EMC) website at: <https://www.epa.gov/emc/emc-other-test-methods>.

The posting of a test method on the **Other Test Methods** portion of the EMC website is neither an endorsement by EPA regarding the validity of the test method nor a regulatory approval of the test method. The purpose of the Other Test Methods portion of the EMC website is to promote discussion of developing emission measurement methodologies and to provide regulatory agencies, the regulated community, and the public at large with potentially helpful tools.

Other Test Methods are test methods which have not yet been subject to the Federal rulemaking process. Each of these methods, as well as the available technical documentation supporting them, have been reviewed by the EMC staff and have been found to be potentially useful to the emission

measurement community. The types of technical information reviewed include field and laboratory validation studies; results of collaborative testing; articles from peer-reviewed journals; peer review comments; and quality assurance (QA) and quality control (QC) procedures in the method itself. A table summarizing the available technical information for each method can be found at the link below. The EPA strongly encourages the submission of additional supporting field and laboratory data as well as comments in regard to these methods.

These methods may be considered for use in federally enforceable State and local programs (e.g., Title V permits, State Implementation Plans (SIP)) provided they are subject to an EPA Regional SIP approval process or permit veto opportunity and public notice with the opportunity for comment. The methods may also be considered to be candidates to be alternative methods to meet Federal requirements under 40 CFR Parts 60, 61, and 63. However, they must be approved as alternatives under 60.8, 61.13, or 63.7(f) before a source may use them for this purpose. Consideration of a method's applicability for a particular purpose should be based on the stated applicability as well as the supporting technical information outlined in the table. The methods are available for application without EPA oversight for other non-EPA program uses including state permitting programs and scientific and engineering applications.

As many of these methods are submitted by parties outside the Agency, the EPA staff may not necessarily be the technical experts on these methods. Therefore, technical support from EPA for these methods is limited, but the table contains contact information for the developers so that you may contact them directly. Also, be aware that these methods are subject to change based on the review of additional validation studies or on public comment as a part of adoption as a Federal test method, the Title V permitting process, or inclusion in a SIP.

Method History

Final – TBD

EPA advises all potential users to review the method and all appendices carefully before application of this method

OTHER TEST METHOD 37 (OTM-37)

MEASUREMENT OF PRIMARY (DIRECT) PM_{2.5} AND PM₁₀ EMISSIONS AT LOW CONCENTRATIONS BY DILUTION SAMPLING (CONSTANT SAMPLING RATE PROCEDURES)

TABLE OF CONTENTS

1.	SCOPE AND APPLICABILITY	- 3 -
2.	SUMMARY OF METHOD	- 5 -
3.	DEFINITIONS	- 6 -
4.	[Reserved].....	- 6 -
5.	SAFETY	- 6 -
6.	EQUIPMENT AND SUPPLIES.....	- 7 -
7.	REAGENTS AND STANDARDS	- 15 -
8.	SAMPLE COLLECTION, PRESERVATION, STORAGE, AND TRANSPORT	- 16 -
9.	QUALITY CONTROL	- 35 -
10.	CALIBRATION AND STANDARDIZATION.....	- 36 -
11.	ANALYTICAL PROCEDURES	- 39 -
12.	CALCULATIONS AND DATA ANALYSIS	- 40 -
13.	METHOD PERFORMANCE.....	- 60 -
14.	POLLUTION PREVENTION.....	- 61 -
15.	WASTE MANAGEMENT	- 61 -
16.	REFERENCES.....	- 61 -
17.	TABLES, FIGURES, FLOWCHARTS, AND VALIDATION DATA.....	- 63 -
	APPENDIX A: [reserved]	- 78 -
	APPENDIX B: Venturi Calibration and Calculations.....	- 79 -

TABLES

Table 1:	Typical Particulate Matter Concentrations.....	- 63 -
Table 2:	Required Cyclone Cut Diameters (D_{50}).....	- 63 -
Table 3:	ΔH_1 Values Based on Preliminary Traverse Data	- 63 -

FIGURES

Figure 1:	OTM37 dilution sampling train for low PM ₁₀ and/or PM _{2.5} concentrations.	- 64 -
Figure 2:	Dilution sampler pressure, temperature and relative humidity instrumentation.....	- 65 -
Figure 3:	Design specifications for cyclone I (10 micrometers).....	- 66 -
Figure 4:	Design specifications for cyclone IV (2.5 micrometers).....	- 67 -
Figure 5:	Design specifications for cyclone I (10 micrometers) sample nozzles.....	- 68 -

Figure 6:	Design specifications for cyclone IV (2.5 micrometers) sample nozzles.....	- 69 -
Figure 7:	Gas flow blockage by the combined cyclone sampling head.....	- 70 -
Figure 8:	Acceptable sample gas flow rate for combined cyclone heads.....	- 71 -
Figure 9:	47 mm filter holder assembly.....	- 72 -
Figure 10:	Filter holder, top.....	- 73 -
Figure 11:	Filter cassette, upper section.....	- 74 -
Figure 12:	Filter support screen.....	- 75 -
Figure 13:	Filter cassette, lower section.....	- 76 -
Figure 14:	Sample recovery scheme.....	- 77 -
Figure B-1:	Venturi flow meter calibration setup.....	- 80 -

1. SCOPE AND APPLICABILITY

1.1 Scope

This method describes the procedure that you--the tester--may follow to measure particulate matter (PM) emissions with a nominal aerodynamic diameter of 2.5 micrometers (μm or microns) ($\text{PM}_{2.5}$) and/or 10 μm (PM_{10}) and smaller. This method collects filterable PM_{10} and/or $\text{PM}_{2.5}$ and condensable PM. You may use this method only on stationary sources.

1.2 Applicability

This method has not been subject to the Federal rulemaking process; however, it has been found to be potentially useful for the measurement of primary PM. This method may be considered for use in Federally Enforceable State and local programs (e.g., Title V permits, state implementation plans (SIP)) provided they are subject to an EPA regional SIP approval process or permit veto opportunity and public notice with the opportunity for comment. This method is also available for application without EPA oversight for other non-EPA program uses including state permitting programs and scientific and engineering applications.

This method will be used by operators of stationary sources needing to quantify emissions of primary $\text{PM}_{2.5}$ and/or PM_{10} . Primary $\text{PM}_{2.5}$ emissions include filterable and condensable $\text{PM}_{2.5}$ emissions that exist or form through reactions as emissions reach ambient temperatures. This method may only be applied to sources with no entrained water droplets and provided that the relative humidity of the diluted stack gas sample is maintained below 100 percent. This method also may be especially useful for measuring $\text{PM}/\text{PM}_{10}/\text{PM}_{2.5}$ emission concentrations below approximately 10 milligrams (mg) per dry standard cubic meter (dscm) or with cumulative net weight gains below approximately 10 mg, such as fossil fuel- and gaseous fuel-fired boilers, process heaters and steam generators including units utilizing clean gas fuels such as natural gas.

This method may be used to separate the coarse and the fine components of filterable particulate matter emissions. The coarse component is particulate matter that has a nominal aerodynamic diameter of 10 μm and smaller but larger than 2.5 μm . The coarse particulate matter is recovered from the back half of the PM_{10} sizing device (i.e., cyclone I turnaround cup and inner down-comer line), the front half of the $\text{PM}_{2.5}$ sizing device (i.e., cyclone IV cup) and the tubing connecting the two cyclones.

The fine component ($\text{PM}_{2.5}$) is particulate matter that has a nominal aerodynamic diameter of 2.5 μm and smaller. The fine particulate matter is recovered from the exit tube of cyclone IV, the interior surfaces of all hardware between cyclone IV and the sample filter (probe, sample venturi, dilution chamber, mixing chamber and front half filter holder), and the sample filter.

By summing the coarse and fine components, this method measures PM_{10} . If desired, the particulate matter larger than 10 μm also may be measured using this method provided that a full stack traverse in accordance with Method 1 requirements is performed and with the knowledge that the results may be biased due to local isokinetic sampling rate deviations within the stack cross-section. The method may be used with both cyclones or with either the PM_{10} or $\text{PM}_{2.5}$ cyclone alone, depending on test objectives.

The measured $\text{PM}_{2.5}$ consists of both $\text{PM}_{2.5}$ that is solid or liquid at stack conditions and any particulate matter that condenses as the samples reach ambient conditions after dilution. The condensable PM is collected on the 47 mm polytetrafluoroethylene (PTFE) membrane sample filter and recovered from the sections of the sampling trains after the cyclone(s) and before the sample filter. By summing the filterable components, this method may measure total $\text{PM}_{2.5}$, total PM_{10} , and/or total PM.

1.3 Responsibility

You are responsible for obtaining the equipment and supplies you will need in this method. You must also develop your own standard operating procedures for conducting this method and any additional procedures to ensure accurate sampling and analytical measurements.

1.4 Additional Methods and Procedures

This is a complex test method. To obtain reliable results, you must be trained and experienced in the use of in-stack filtration systems and their operations, isokinetic sampling procedures in general, EPA Method 201A, and the procedures of this test method. You must have a thorough knowledge of the following methods and procedures:

- Method 1 - Sample and Velocity Traverses for Stationary Sources (40 CFR Part 60, Appendix A-1);
- Method 2 - Determination of Stack Gas Velocity and Volumetric Flow Rate (Type S Pitot Tube) (40 CFR Part 60, Appendix A-1);
- Method 3 - Gas Analysis for Carbon Dioxide, Oxygen, Excess Air, and Dry Molecular Weight (40 CFR Part 60, Appendix A-2);
- Method 4 - Determination of Moisture Content in Stack Gases (40 CFR Part 60, Appendix A-3);
- Method 5 - Determination of Particulate Matter Emissions from Stationary Sources (40 CFR Part 60, Appendix A-4);
- Method 17 - Determination of Particulate Matter Emissions from Stationary Sources (40 CFR Part 60, Appendix A-6);
- Method 201A (2010) - Determination of PM₁₀ and PM_{2.5} Emissions (Constant Sampling Rate Procedures) (40 CFR Part 51, Appendix M);
- Reference Method for the Determination of Fine Particulate Matter as PM_{2.5} in the Atmosphere (40 CFR 50, Appendix L);
- Monitoring PM_{2.5} in Ambient Air Using Designated Reference or Class I Equivalent Methods, Quality Assurance Guidance Document 2.12, EPA-454/B-16-001, U.S. EPA, National Exposure Research Laboratory. Research Triangle Park, NC. January 2016.

1.5 Limitations

1.5.1 Water droplets

You must not use this method to measure emissions in stack gases containing water droplets. Stack gases with entrained water droplets may have droplets larger than the cut sizes for the cyclones and these droplets may contain solids, liquids and dissolved vapors that would become PM₁₀ and PM_{2.5} particulate matter when released to the ambient air and the water evaporates.

1.5.2 High stack gas temperatures

Stainless steel in-stack cyclone assemblies with threaded connections cannot be used for sources with stack gas temperatures above approximately 370 °C (700 °F) because the threaded connections will gall and seize, precluding sample recovery and permanently damaging the assembly.

NOTE: *In-stack cyclone assemblies constructed using flanged break-away bolt connections and/or using high-temperature alloys have been successfully used for high temperature stack gases. A sample train configuration using an external heated cyclone located in an oven between the probe and sample venturi similar to that used in Other Test Method 036 also has been used; this may be useful*

for trapping a portion but not all of the particles larger than the cyclone cutoff diameter (some large particles may be collected in the probe upstream of the cyclone).

This method seeks to minimize particle deposition in the sample probe due to thermophoresis by maintaining probe temperature slightly above the temperature of the stack gas. It may not be practical to maintain the sample probe temperature higher than the stack gas temperature for sources with high stack gas temperatures. Particle deposition in the sample probe may become significant when the probe temperature is cooler than the stack gas temperature. When the sample gas absolute temperature at the sample venturi is more than 2% lower than the stack gas absolute temperature, the sample probe and venturi recovery rinse procedure must be performed (Container 4A in Figure 14 of Section 17).

Higher stack gas temperatures and/or high stack gas moisture concentrations may require higher dilution ratios, increased dilution air drying and/or lower dilution air temperatures to achieve the upper diluted sample temperature and relative humidity specified in this method. This should be carefully considered during test planning and sampling train configuration to assure that dilution conditions will meet method specifications and test objectives.

1.5.3 Ambient air conditions

This method specifies dilution air conditioning to meet upper temperature and relative humidity specifications for the diluted stack gas sample. The dilution air conditioning system must have sufficient drying and thermal capacity to accommodate high or low ambient air temperatures and high ambient air humidity when such conditions are expected.

Note: It may be difficult to achieve method specifications for diluted sample temperature and relative humidity during periods with very high or very low ambient air temperatures and/or elevated absolute humidity. Users of similar methods have found it beneficial to conduct test programs during periods of optimal ambient conditions (e.g., at night or during a more moderate annual season).

2. SUMMARY OF METHOD

This method combines particle size separation principles of Method 201A with a system that dilutes and cools the sample gas prior to collection of the PM passing through the size separation stage, including condensable PM, on a membrane filter. Stack gas is extracted at a pre-determined constant sample gas flow rate to achieve near isokinetic sampling rates through in-stack PM₁₀ and/or PM_{2.5} cyclones. The cyclones separate particles with nominal aerodynamic diameters of greater than 10 µm, less than 10µm and greater than 2.5 µm, and allow particles 2.5 µm and smaller entrained in the stack gas sample to continue through the heated sample probe and heated sample venturi. The stack gas sample is diluted with filtered, dehumidified, and temperature-adjusted air prior to and at the mixing cone. After mixing the dilution air and stack sample gas to allow for particulate condensation and gas-particle interaction, PM_{2.5} is captured on a 47 mm PTFE membrane sample filter. A schematic of the sampling train can be found in Figure 1 of Section 17.

To recover the samples after a test, all sample transport surfaces of the cyclones, probe, sample venturi, venturi-cone connector tube and pre-dilution tee in contact with the stack gas sample are rinsed with acetone (see Figure 14 of Section 17). The mixing cone, mixing chamber, and filter holder inlet are first rinsed with DI water and then with acetone. These rinses are evaporated to dryness, desiccated and analyzed gravimetrically to determine the particulate mass (PM₁₀ and/or PM_{2.5}) in each sample fraction. The 47 mm PTFE membrane sample filter is conditioned at 20-23 °C (68-73 °F) and 30-40 percent relative humidity and then weighed to determine the particulate mass (PM_{2.5}).

3. DEFINITIONS

Condensable particulate matter means material that is vapor phase at stack conditions, but condenses and/or reacts upon cooling and dilution in the ambient air to form solid or liquid PM as the emissions reach ambient temperature. Note that all condensable PM is assumed to be in the PM_{2.5} size fraction.

Constant weight means a difference of no more than 0.05 mg or 1 percent of net weight (final weight less tare weight), whichever is greater, between two consecutive weighings, with no less than 6 hours of desiccation time between weighings.

Direct PM (also known as "primary PM") means solid or liquid particles emitted directly from an air emissions source or activity or reaction products of gases emitted directly from an air emissions source or activity which form particulate matter as they reach ambient temperatures. Direct PM emissions include filterable and condensable PM emissions composed of elemental carbon, directly emitted organic carbon, directly emitted sulfate, directly emitted nitrate, and other organic or inorganic particles that exist or form through reactions as emissions reach ambient temperatures (including but not limited to crustal material, metals, and sea salt).

Electropolished means polishing a material to a uniform bright finish (no surface finish Ra is specified) in accordance with ASTM B912-13 "Standard Specification for Passivation of Stainless Steels Using Electropolishing".

Field train proof blank means a sample train that is cleaned, fully assembled, leak checked twice, recovered and analyzed in the same manner as the sample trains used for sample collection.

Filterable particulate matter means solid or liquid particles emitted directly from an air emissions source or activity and captured on the filter of a stack test train.

Filterable PM_{2.5} means filterable PM with a nominal aerodynamic diameter of 2.5 micrometers and smaller.

Filterable PM₁₀ means filterable PM with a nominal aerodynamic diameter of 10 micrometers and smaller.

PM_{2.5} means filterable PM_{2.5} plus condensable particulate matter.

PM₁₀ means filterable PM₁₀ plus condensable particulate matter.

Stainless steel refers to a grade of stainless steel that is resistant to corrosion (i.e., 316 grade or equivalent).

Titanium refers to a grade of titanium that meets the criteria found in ASTM B265 (i.e., Grade 2 or equivalent).

4. INTERFERENCES

[Reserved]

5. SAFETY

The procedures required in this method may involve hazardous materials, operations, and equipment. This method does not address all of the safety issues associated with these procedures. It is the responsibility of the user to establish appropriate safety and health practices and determine the applicable regulatory limitations prior to performing these procedures. Organizational and site-specific health and safety guidelines and rules should be consulted for specific precautions to be taken.

5.1 Site Hazards

Prior to applying these procedures/specifications in the field, the potential hazards at the test site should be considered; advance coordination with the site is critical to understand the conditions and applicable safety policies. At a minimum, portions of the sampling system will be hot, requiring appropriate gloves, long sleeves, and caution in handling this equipment.

5.2 Laboratory Safety

Policies should be in place to minimize risk of chemical exposure and to properly handle waste disposal in the laboratory. Personnel are advised to wear appropriate laboratory attire and personal protective equipment according to a Chemical Hygiene Plan established by the laboratory.

5.3 Reagent Toxicity/Carcinogenicity

The toxicity and carcinogenicity of any reagents used must be considered (this method specifies the use of acetone in equipment cleaning and sample recovery procedures). This measurement may involve exposure to hazardous materials, operations, and equipment and this method does not address all of the potential safety hazards associated with implementing this approach. It is the responsibility of the user to establish appropriate safety and health practices and determine the applicable regulatory limitations prior to performance. Any chemical should be regarded as a potential health hazard and exposure to these compounds should be minimized. Users should refer to relevant Safety Data Sheets (SDS) for chemicals specified in this method or at the measurement site.

5.4 Waste Disposal

Any waste generated by this procedure must be disposed of according to a hazardous materials management plan that details and tracks various waste streams and disposal procedures.

6. EQUIPMENT AND SUPPLIES

6.1 Sampling Train

Figures 1 and 2 of Section 17 of this method present a sampling train schematic for this test method. The sampling train consists of sample extraction and collection equipment as well as dilution supply air equipment for supplying clean, dry mixing air. The following paragraphs describe the sampling train's primary design features in detail.

6.1.1 Stack gas sample extraction and collection equipment

6.1.1.1 PM₁₀ and PM_{2.5} cyclones

Choose a stainless steel PM₁₀ and/or PM_{2.5} cyclone with the internal surfaces electropolished. Viton® or silicone rubber O-rings used in the cyclone sampling head have an upper temperature limit of approximately 205 °C (400 °F). PTFE O-rings may be used for temperatures up to approximately 316 °C (600 °F). Use cyclones with stainless steel sealing rings for stack temperatures above approximately 205 °C (400 °F).

Stainless steel cyclones with threaded components may not be suitable for sources with stack gas temperatures exceeding approximately 260 °C (500 °F) because the threads may gall or seize, thus preventing the recovery of the collected PM and rendering the cyclones unusable for subsequent use. You may use stainless steel cyclone assemblies constructed with bolt-together rather than screw-together assemblies for temperatures up to approximately 538 °C (1,000 °F). You must use "break-away" (expendable) stainless steel bolts that can be over-torqued and broken if necessary to release cyclone closures, thus allowing you to recover the sample without damaging the cyclone flanges or contaminating the samples. For temperatures above approximately 538 °C (1,000 °F), you may use cyclones constructed of high-temperature stainless steel alloys with bolt-together closures and break-away bolts.

The cyclones must meet the design specifications shown in Figures 3 and 4 of Section 17. Use a caliper to verify the dimensions of the cyclones to within ± 0.02 cm (± 0.01 inch) of the design specifications.

6.1.1.2 Nozzle

You must use an electropolished stainless steel nozzle with a sharp tapered leading edge. Nozzle composition and electropolishing requirements are the same as those specified for the PM₁₀/PM_{2.5} cyclones. You should have a selection of nozzles in small diameter increments available for the cyclone being used to ensure that you can select the appropriate nozzle for your field test conditions. When only the PM_{2.5} cyclone is used, you must use a nozzle made for the PM_{2.5} cyclone.

We recommend that you choose one of the nozzles listed in Figures 5 or 6 of Section 17 because they meet the design specifications for this method.

6.1.1.3 Pitot tube

You must use an S-type pitot tube made of heat resistant tubing. The Pitot tube can be welded to the probe sheath or attached using appropriate fittings. Follow the specifications for the Pitot tube and its orientation to the inlet nozzle given in paragraph 6.1.1.3 of Method 5 (Reference 7).

6.1.1.4 Probe liner

You will need a probe liner made of seamless electropolished titanium tubing with a heating system capable of maintaining a probe exit gas temperature during sampling within ± 3 °C (± 5.4 °F) of the desired temperature setting of at least 5 °C (9 °F) above the stack gas temperature.

Since the actual undiluted sample gas temperature at the outlet of the probe is not usually monitored during sampling, probes constructed according to APTD-0581 and utilizing the calibration curves of APTD-0576 (or calibrated according to the APTD-0576 procedures) will be considered acceptable.

NOTE: Electrically conductive probe liner materials are required to minimize particle deposition in the probe liner due to electrostatic charge. Borosilicate, quartz glass, PTFE and other electrically non-conductive probe liners are not recommended because particle deposition in the probe liner due to electrostatic charge may increase.

6.1.1.5 Differential pressure transducers

You will need electronic pressure transducers or equivalent pressure measuring devices. Transducers shall be used for measuring the pitot velocity head, the sample venturi and dilution air venturi differential pressures, the stack gas static pressure, the cyclone pressure drop, and the static pressure at the mixed gas RH sensor. The pressure transducers shall have the ranges specified in Figure 2 of Section 17 and an accuracy of ± 0.25 percent of full scale range or better. In addition, pressure-measuring devices must be selected such that the zero and span do not drift by more than 5 percent of the average expected pressure readings over the range of environmental conditions expected during the field test.

6.1.1.6 Heating system/compartments

Any heating system capable of maintaining a temperature around the sample venturi to within ± 3 °C (± 5.4 °F) of the desired temperature setting of at least 5 °C (9 °F) above the stack gas temperature.

6.1.1.7 Temperature sensors

You will need temperature sensors capable of measuring temperature to within ± 1.1 °C (± 2 °F). The temperature sensors for gas temperatures must be installed so that the sensing tip is in direct contact with the sample gas or air.

6.1.1.8 Sample venturi

You will need a calibrated subsonic venturi flow meter consisting of a converging cone, venturi throat, and diffuser. The venturi tube must be constructed of stainless steel with electropolished surfaces in contact with the sample. The internal surfaces in contact with the sample gas must be electropolished. The inlet section to the sample venturi will consist of a converging cone that has an included angle of 21 degrees. The outlet section of the venturi tube will consist of a diverging cone that has an included angle of 7 to 8 degrees.

6.1.1.9 Couplers, fittings, reducers, and unions

You will need connectors or couplers to assemble the portions of the sampling train (e.g., to connect the PM_{2.5} cyclone IV to the probe, to connect the probe to the sample venturi, and to connect the sample venturi to the mixing chamber, etc.). You will need stainless steel sanitary flange fittings with seal rings to connect the dilution hose to the inlet of the mixing cone holder, to connect the mixing chamber between the cone holder exit and the exhaust filter holder inlet and to connect the sample filter holders to the exhaust filter holder inlet.

6.1.1.10 Mixing cone and holder

You will need a mixing assembly to mix the clean dry dilution air with the stack sample gas to achieve a uniform concentration of the PM. The mixing assembly consists of a mixing cone and holder where the dilution air makes initial contact with the stack sample gas.

The mixing cone is placed in the cone holder. The cone and cone holder composition and electro polishing requirements are the same as those specified for the PM₁₀/PM_{2.5} cyclones and the nozzle. The mixing cone holder is round with a 10.1 cm (4 inch) nominal inside diameter and is approximately 12.7 cm (5 inches) long. The base (or inlet end) of the cone holder has a circular opening to allow the connection of the sample venturi-cone connector tubing and the inlet of the mixing cone. Near its base, the cone holder has a 38 mm (1.5 inch) diameter sanitary flange connection for the dilution air supply line.

A slipstream of the dilution supply air is diverted through the sample venturi heated compartment, allowing the slipstream of dilution air to be preheated and provide an annular flow of heated air surrounding the exit of the sample line at the mixing cone sample inlet. The open face (or exit end) of the cone holder is flanged to allow for a connection to the mixing chamber. The mixing cone's ability to completely and rapidly mix the sample and dilution streams must be verified prior to sampling using the procedures found in Section 10.7.

Note: While this section specifies the mixing cone design as a cone, other mixing designs (e.g., jet entrainment, mixing orifice, venturi, etc.) may be used, so long as these designs meet the specifications found in Section 10.7.

6.1.1.11 Mixing chamber

The mixing chamber is used to allow for the completion of mixing between the dilution air and raw stack gas sample. The mixing chamber must be constructed of stainless steel and should have sanitary flange-type fittings at both ends to allow for connections to the mixing cone holder and the exhaust filter inlet. It must have a nominal diameter of 10 centimeters (cm) (4 inches) and a length of at least 43 cm (17 inches). The chamber surfaces in contact with the sample gas must be electropolished.

6.1.1.12 Exhaust filter holder assembly

The exhaust filter holder for 142 mm round exhaust filter mats must be made of stainless steel. The inlet or front half of the exhaust filter holder must be constructed so that it has a sanitary flange for connecting to the mixing chamber. The surfaces of the filter holder inlet and fittings in contact with

the diluted stack gas sample upstream of the exhaust filter must be electropolished stainless steel. The filter support must include a stainless steel screen frit support, a fine mesh frit, a Viton® O-ring, and a sanitary flange clamp. The filter holder exit must be of a diameter to allow connecting to a 64 mm (2.5 inch) diameter flexible hose coupler.

The exhaust filter holder inlet must include one or more (typically three) 38 mm (1.5 inch) diameter sanitary flange fittings to accommodate attachment of 47 mm filter holder assemblies. A total of three 38 mm (1.5 inch) sanitary flange fittings is recommended to accommodate replicate samples and/or sample speciation media. The 38 mm (1.5 inch) sanitary flange fittings must be oriented such that the exposed surfaces of all sample filters is approximately upward.

The exhaust filter holder design must provide a positive seal against leakage from the outside or around the filter. The exhaust filter holder must include a Viton® O-ring seal, a stainless steel O-ring separator shim, a stainless steel screen which supports the filter, and a final PTFE or PTFE-coated rubber O-ring seal.

6.1.1.13 Exhaust gas blower with DC motor control

You must use a regenerative air blower for inducing the main gas flow through the sampling train. The blower must be able to provide 850 liters per minute (L/min) (30 cubic feet per minute, cf/min) of gas flow at a pressure of 762 mm of mercury (30 inches of water column, iwc). The blower must also be equipped with an electric motor and direct current (DC) motor speed control so that the blower speed can be automatically controlled by the DACS to maintain target dilution ratios and sample flow rates.

6.1.1.14 Relative humidity sensor

You will need a relative humidity sensor for real-time monitoring of the amount of water vapor (i.e., moisture) in the mixed gas (i.e., stack sample gas and dilution supply air mixture). The relative humidity sensor must have an accuracy of ± 2 percent from 0 to 90 percent relative humidity or better. The operating temperature range of the relative humidity sensor must be from -10 to +50 °C (14 to 122 °F).

6.1.1.15 Flexible exhaust gas hoses

You will need a section of flexible reinforced polyvinyl (or other suitable material) hose to connect the exhaust filter holder outlet to the exhaust gas blower inlet. The hose must be reinforced to prevent collapse under mild vacuum pressures during normal operation.

6.1.1.16 Equipment heat trace

You will need an electrical heating tape or custom-fitted heating blankets and insulation wrap to maintain the entire exposed surface temperature of the mixing cone holder, mixing chamber and filter holder inlets above the water dew point (saturation temperature) of the mixed gas (diluted sample) but not higher than 20 °C (85 °F). You may need a temperature controller for each heating tape or heating blanket.

6.1.1.17 Mass flow meters

You will need at least two mass flow meters (MFM) to measure the sample filter and the dilution air blank filter flow rates. Coarse particulate filters and water removal systems must be installed between the filters and the MFMs to protect the MFMs from particles or water droplets. The MFMs must be capable of metering the sample volume required and measuring this volume to within 2 percent of reading of a representative gas.

Mass flow meters must be calibrated prior to field use according to Section 10.3.3 of this Method.

NOTE: Water vapor in the gas sample significantly interferes with the accuracy of some commercially-available thermal mass flow meters, even at volume concentrations below 2 percent. If you are using

thermal mass flow meters, you must use a dryer to remove water vapor from the dilution air and mixed gas entering the MFMs. A silica gel or anhydrous calcium sulfate cartridge with sufficient absorbing capacity for the duration of the tests may be used.

6.1.1.18 Vacuum pump

You will need a vacuum pump to draw diluted sample and dilution air through the sample and dilution air blank filters. The capacity of the vacuum pump should be sufficient to draw 25 liters per minute (1.3 cubic feet per minute) through each filter at a maximum vacuum sufficient to draw samples and perform leak checks. The sample pump must have a vacuum gage to measure the pump inlet vacuum. The pump exhaust may be vented to atmosphere.

6.1.1.19 Sample filter flow control valves

You will need an in-line valve located between the filter outlet and pump inlet for each sample and dilution air blank filter to adjust the flow rates through the filters.

6.1.1.20 Sample (47 mm) filter holder assemblies

The sampler must have leak-free filter holder assemblies to adapt and seal the filter holder inlet to the 38 mm (1.5 inch) sanitary flange adapter fitting and to hold and seal a 47 mm filter cassette, specified in section 7.1.2 of this method, such that the diluted stack gas sample or dilution air passes through the filter at a uniform face velocity.

The upper (inlet) portion of this assembly must be fabricated as indicated in Figures 9 and 10 in section 17.0 of this method and must accept and seal with the filter cassette, which must be fabricated as indicated in Figures 11 through 13 in section 16 of this method. The upper portion of this assembly must include a tapered or similar inlet adapter (not shown in the Figures) transitioning the filter holder inlet diameter to a 38 mm (1.5 inch) sanitary flange fitting for direct connection to a corresponding fitting on the exhaust filter holder inlet.

The lower portion of the filter holder assembly must be of a design and construction that:

- Mates with the upper portion of the assembly to complete the filter holder assembly,
- Completes both the external air seal and the internal filter cassette seal such that all seals are reliable over repeated filter changings, and
- Facilitates repeated changing of the filter cassette by the sampler operator;
- Mates with a fitting to connect the filter outlet to a mass flow meter;
- Incorporates a fitting to facilitate connection of a thermocouple for measuring the temperature of the diluted stack gas sample at the outlet of the filter holder.

6.1.1.21 Sample and dilution air blank filter connectors and fittings

You will need flexible polyethylene or PTFE tubing and fittings to connect the 47 mm filter holder outlets, flow control valves, protection filters and vacuum pump.

6.1.1.22 Data acquisition and control system

The sampler must have an electronic data acquisition and control system (DACS) to record instrument signals, convert instrument signals to engineering parameters, and control system flow rates. The DACS must have signal input modules compatible with temperature sensor, pressure transducer and other instrument output signals. Pressure transducers, temperature sensors and other instruments must have signal outputs compatible with the DACS. The DACS should calculate test parameters required to operate and monitor sampler operation according to this Method and test requirements. The DACS should provide automatic control of exhaust and dilution air flow rates to maintain operation conforming to this method and test requirements (with provision for manual override in special

situations). The DACS should provide for user input parameters including but not limited to instrument calibration factors, pre-test calculations, target operating conditions, and other parameters as necessary to conduct the test. The DACS must record and should display instrument outputs and calculated parameters in engineering units for documentation of sampler operation during each test.

6.1.2 Dilution air supply equipment

6.1.2.1 Dehumidifier/cooler/heater

If the relative humidity of the dilution air is greater than 50 percent, you will need a dehumidifier. A cooled condenser or sorbent bed drier may be used to dehumidify the dilution air. If the dilution air temperature is greater than 27 °C (80 °F), you will need a cooling system to cool the dilution air such that the temperature of the resulting mixed dilution air and stack gas sample at the exhaust filter is 29 °C (85 °F) or lower. A gas-liquid heat exchanger and circulating liquid cooling medium may be used. The total pressure drop across the dehumidifier and cooling system must not restrict the dilution air flow rate below that required for testing. If the ambient conditions are favorable, you may not need to use either a dehumidifier or cooling system.

Note: When ambient temperatures are relatively low, it may be acceptable for the dilution air supply to have a relative humidity of greater than 50 percent so long as no condensation is observed in the aging chamber.

6.1.2.2 Dilution air blower with dc motor control

You will need a regenerative air blower to supply dilution air to the mixing chamber. The blower must be able to provide 850 L/min (30 cf/min) at a pressure of 762 mm of mercury (30 iwc). The blower should also be equipped with direct current (DC) motor control so that flow can be adjusted during the test to maintain the required dilution air flow rate. The inlet and outlet of the blower should be fitted with sanitary flange fittings for direct connection to other dilution air supply components.

6.1.2.3 Relative humidity sensor

You will need a relative humidity sensor for real-time monitoring of the dilution air moisture. The RH sensor must have an accuracy of ± 2 percent from 0 to 90 percent relative humidity or better. The operating temperature range of the RH sensor must be from -10 to 50 °C (14 to 122 °F). The relative humidity sensor should be installed in a section of stainless steel tubing with sanitary flange fittings on the inlet and outlet for direct connection of the assembly to other dilution air supply components.

6.1.2.4 Dilution air particulate filter and filter housing

You will need an ultra-low penetration air (ULPA) filter or equivalent filter that provides a minimum collection efficiency of 99.9995 percent for 0.12 μm and larger particles. The dilution air particulate filter must be rated for a minimum air flow rate of 1130 liters per minute (40 cubic feet per minute) at a maximum pressure drop that does not restrict the dilution air supply below that required for the test, and the collection efficiency test shall be conducted according to ISO 29463.

The dilution air particulate filter housing must provide for a positive seal such that air does not bypass the filter. The dilution air particulate filter housing inlet and outlet should be fitted with sanitary flange fittings for direct connection to other dilution air supply components.

6.1.2.5 Dilution air activated carbon filter

You will need an activated carbon filter for the dilution air supply. The activated carbon filter must be placed upstream of the dilution air particulate filter and must be capable of removing volatile organic compounds from the dilution air with good to high efficiency.

NOTE: *Granulated activated carbon beds or activated carbon-impregnated fiber filters may be used. The activated carbon filter may be located with the dilution air particulate filter in the same filter*

housing if the filter housing is designed to accommodate both filters, or it may be placed in a separate filter housing and attached upstream of the dilution air particulate filter inlet.

6.1.2.6 Dilution air venturi

You will need a calibrated subsonic venturi flow meter consisting of a converging cone, venturi throat, and diffuser. Since only dry, clean air will be contacting the venturi surfaces, the dilution air venturi tube may be constructed of any non-reactive material (stainless steel, aluminum, etc.). The inlet section to the venturi tube will consist of a converging cone that has an included angle of 21 degrees. The outlet section of the venturi tube will consist of a diverging cone that has an included angle of 7 to 8 degrees. The dilution air venturi inlet and outlet should be fitted with sanitary flange fittings for direct connection to other dilution air supply components.

6.1.2.7 Temperature sensors

You will need to monitor dilution air temperature near the relative humidity sensor (see Figure 2 in Section 17). You will need a temperature sensor similar to those described in Section 6.1.1.7.

6.1.2.8 Flexible dilution air hose

You will need sections of flexible polyvinyl (or other suitable material) hose to connect the dehumidifier to the dilution air blower and dilution air venturi to the mixing chamber.

6.1.2.9 Hose couplers and miscellaneous fittings

You may need miscellaneous fittings such as hose couplers and reducers for connecting the flexible hoses to the various train components.

6.1.2.10 Dilution air blank filter holder, MFM, flow control valve, sample pump, tubing and fittings

A 47 mm filter is required for collecting dilution air blank samples. The dilution air blank filter holder should be located in the dilution air supply downstream of the dilution air particulate filter. See 6.1.1.17 through 6.1.1.21 for mass flow meter, sample pump, filter holder, and related specifications.

6.1.2.11 Dilution air blank filter holder adapter tee

You will need a 38 mm (1.5 inch) diameter tee constructed of stainless steel with 1.5 inch diameter sanitary flange fittings on each opening. All surfaces must be electropolished stainless steel.

6.2 Leak check equipment

You will need the following equipment to leak check the sampling equipment.

6.2.1 Pump

You may use a vacuum gauge, leak-free pump, a needle valve and a mass flow meter as specified in section 6.1.1.17 of this method.

6.2.2 Leak check adapter

You will need a leak check adapter to attach to the exit of the exhaust filter holder to perform leak checks. The assembly consists of a PVC tube section with a port connection with a female quick-connect fitting, a normal hose coupler, and a plugged coupler.

You will need a blanking plate for each of the 38 mm (1.5 inch) diameter sanitary flange fittings (for 47 mm filter holders) on the exhaust filter holder inlet and dilution air supply. You may need a blanking plate for the mixing tube inlet.

6.2.3 Umbilical line

You will need an umbilical line to connect to the leak check adapter quick-connect and the pump.

6.3 Sample recovery equipment

You will need the following equipment to quantitatively determine the amount of particulate matter recovered from the sampling train.

6.3.1 Recovery equipment

You will need nylon or PTFE bristle brushes with stainless steel wire or PTFE handles. The probe brush will have extensions (slightly longer than the probe) constructed of stainless steel, PTFE, or similarly inert material. The brushes must be properly sized and shaped to brush out the nozzles, PM_{2.5} and PM₁₀ cyclones, probe liner, sample venturi tube, sample venturi-cone connector, mixing cone, mixing chamber, and exhaust filter holder inlet.

6.3.2 Wash bottles

You must use PTFE wash bottles.

6.3.3 Glass recovery rinse sample storage containers

You must use amber glass bottles with PTFE-lined lids or other non-reactive bottles (e.g., High Density Linear Polyethylene (HDLPE), or PTFE) pre-cleaned sample bottles for water samples. Amber glass bottles with PTFE-lined lids must be used for organic samples.

6.3.4 Funnel

You may use a glass funnel to aid in collecting acetone and water recovery rinses into the sample jars.

6.3.5 Sample and dilution air blank protective containers

You will need protective containers for the 47 mm sample and dilution air blank filter cassettes. Use the same protective containers in which the sample cassettes pre-loaded with conditioned and tared 47 mm filters were transported prior to testing. See reference 11 in Section 16.0 of this method for further guidance.

6.3.6 Disposable powderless nitrile safety gloves

You will need disposable powderless nitrile or neoprene safety gloves to wear at all times when handling sampling equipment during cleaning and when recovering samples.

6.4 Sample preparation and analysis sample analysis

6.4.1 Equipment for recovery rinse analysis

You will need a desiccator and containers such as glass beakers with fluoropolymer liners or other non-reactive low mass containers. You will need an analytical balance capable of measuring particulate mass to within 0.01 mg for recovery rinses (if these samples will be analyzed). The balance should be in a controlled environment capable of maintaining a relative humidity of less than 50 percent and a temperature of 20 °C ±5.6 °C (68 °F ±10 °F).

6.4.2 Equipment for 47 mm filter analysis

The analytical balance used to weigh 47 mm filters must be suitable for weighing the type and size of filters specified under section 7.1.1 of this method, and must have a readability of ±1 µg. The balance must be calibrated as specified by the manufacturer at installation and recalibrated immediately prior to each weighing session. See reference 11 in section 16.0 of this method for additional guidance.

You will need anti-static strips and a static dissipating pad surrounding the balance to neutralize static charges during weighing.

The analytical balance must be installed in an environmentally-controlled weighing room to maintain the temperature at 21.5° ± 0.5°C and relative humidity at 32.5 percent ±2.0 percent. Temperature

and relative humidity must be continuously recorded. The air in the weighing room must be filtered to reduce particulate matter circulation.

7. REAGENTS AND STANDARDS

7.1 Sample Collection

7.1.1 Exhaust filter

You must use a 142 mm filter made of borosilicate microfibers reinforced with woven glass cloth and bonded with PTFE. The exhaust filter is used for protection of the exhaust relative humidity, temperature and pressure sensors and the exhaust blower.

7.1.2 Sample Filter

The sample filters used for this method are the same as those used for PM_{2.5} ambient air monitoring. Any filter manufacturer or vendor who sells or offers to sell 47 mm PTFE membrane filters specifically identified for use with PM_{2.5} ambient air monitoring reference methods shall certify that the required number of filters from each lot of filters offered for sale as such have been tested as specified in this section 7.1.2 and meet all of the following design and performance specifications. These specifications are consistent with those filters used for the collection of ambient air PM_{2.5} samples according to 40 CFR Part 50, Appendix L.

- Size: Circular, 46.2 mm diameter ± 0.25 mm.
- Medium. Polytetrafluoroethylene (PTFE), with integral support ring.
- Support ring. Polymethylpentene (PMP) or equivalent inert material, 0.38 ± 0.04 mm thick, outer diameter $46.2 \text{ mm} \pm 0.25$ mm, and width of $3.68 \text{ mm} (\pm 0.00, -0.51 \text{ mm})$.
- Pore size. 2 μm as measured by ASTM F316-94.
- Filter thickness. 30 to 50 μm .
- Maximum pressure drop (clean filter). 30 cm water column @ 16.67 L/min clean air flow.
- Maximum moisture pickup. Not more than 10 μg weight increase after 24-hour exposure to air of 40 percent relative humidity, relative to weight after 24-hour exposure to air of 35 percent relative humidity.
- Collection efficiency. Greater than 99.7 percent, as measured by the DOP test (ASTM D 2986-91) with 0.3 μm particles at the sampler's operating face velocity.
- Filter weight stability. Filter weight loss shall be less than 20 μg , as measured in each of the following two tests specified below. The following conditions apply to both of these tests: Filter weight loss shall be the average difference between the initial and the final filter weights of a random sample of test filters selected from each lot prior to sale. The number of filters tested shall be not less than 0.1 percent of the filters of each manufacturing lot, or 10 filters, whichever is greater. The filters shall be weighed under laboratory conditions and shall have had no air sample passed through them, i.e., filter blanks. Each test procedure must include initial conditioning and weighing, the test, and final conditioning and weighing. Conditioning and weighing shall be in accordance with sections 8.1.3 of this method and general guidance provided in reference 11 of section 16.0 of this method.
- Test for loose, surface particle contamination. After the initial weighing, install each test filter, in turn, in a filter cassette (Figures 11, 12 and 13 of this method) and drop the cassette from a height of 25 cm to a flat hard surface, such as a particle-free wood bench. Repeat two times,

for a total of three drop tests for each test filter. Remove the test filter from the cassette and weigh the filter. The average change in weight must be less than 20 µg.

- Test for temperature stability. After weighing each filter, place the test filters in a drying oven set at 40 °C±2 °C for not less than 48 hours. Remove, condition, and reweigh each test filter. The average change in weight must be less than 20 µg.
- Alkalinity. Less than 25 microequivalents/gram of filter, as measured by the guidance given in reference 11 in section 16.0 of this method.
- Supplemental requirements. Although not required for determination of PM_{2.5} mass concentration under this method, additional specifications for the filter must be developed by users who intend to subject PM_{2.5} filter samples to subsequent chemical analysis. These supplemental specifications include background chemical contamination of the filter and any other filter parameters that may be required by the method of chemical analysis. All such supplemental filter specifications must be compatible with and secondary to the primary filter specifications given in this section 7.1.2 of this method.

7.2 Train preparation and sample recovery

7.2.1 Acetone

You must use acetone that is stored in a glass bottle that has a blank value that has blank value less than 1.0 ppmw (0.1 mg/100 g) of residue. Acetone must be stored in the original glass container until immediately prior to each test. All acetone used for sample preparation and recovery in this method must meet this specification.

7.2.2 Water

Use deionized, ultra-filtered water that contains less than 0.5 ppmw (0.05 mg/100g) of residue. For the purpose of this method, all water used for sample preparation and recovery must meet this specification.

Note: It is strongly suggested you use water that meets or exceeds CAP/CLSI specifications for Clinical Laboratory Reagent Water (CLRW) and USP/NF Purified Water. These standards do not include a requirement for residuals, however water made to this standard routinely typically demonstrates residuals of less than 0.1 ppmw (0.01mg/100g).

7.3 Filter Recovery

For analyzing recovery rinses, you will need a desiccant such as anhydrous calcium sulfate, indicating type. You will weigh the beakers and filters after being held in the desiccator containing the desiccant material using the analytical balance described in Section 6.4.1.

8. SAMPLE COLLECTION, PRESERVATION, STORAGE, AND TRANSPORT

8.1 Sample train preparation

8.1.1 Filter check

Check filters visually against light for irregularities, flaws, or pinhole leaks. Label the shipping containers (glass or polystyrene petri dishes, 47 mm filter protective containers), and keep each filter in its identified container at all times except during sampling and weighing.

8.1.2 47 mm filter weighing

Weigh the 47 mm filters as specified in Section 11.2.3 of this Method.

8.1.3 Sampling equipment cleaning

Rinse all portions of the sampling equipment from which PM₁₀ and PM_{2.5} will be recovered (e.g., nozzle, PM₁₀ and PM_{2.5} cyclones, probe, sample venturi, connectors, mixing cone, mixing chamber, and filter holder inlet) with hot tap water and then wash in hot water with laboratory detergent. Next, rinse with tap water, followed by additional rinses with water. Rinse with acetone and allow to air dry.

After washing as specified above, pre-condition new titanium probe liners by rinsing with hexane followed by heating to at least 500°C for at least 1 minute to vaporize any remaining manufacturing oil residues. This may be accomplished using a tube furnace and by heating the probe liner in sections. Draw air through the probe at a low flow rate while heating. After the probe liner has cooled, rinse and brush the probe liner again with deionized distilled water followed by acetone then hexane. Finally, rinse the probe liner with acetone without brushing and collect the rinseate into a sample container, then analyze the rinseate as specified in Section 11.2.1 of this method. If the result is greater than 0.2 milligrams, repeat the steps above until the probe liner acetone rinse blank is 0.2 milligrams or less. Wash the sections of flexible hose that will be used between the dilution air particulate filter exit and the mixing cone holder in hot soapy water, rinse with deionized, distilled water, and allow to air dry.

After washing, assemble the sampling equipment including heating blankets but without the exhaust blower, heat the sampling system to the highest practical temperature above 85°F and less than 300°F, and run filtered air through the system for at least ten minutes to remove all traces of acetone vapor.

After cleaning, cover all openings where contamination can occur until the sampling equipment is assembled for sampling.

8.2 Pre-test evaluation

You must do the following to gather the necessary data for the pre-test calculations:

- Determine the sampling site location and traverse points.
- Calculate probe/cyclone blockage for stacks between 18 and 24 inches in diameter.
- Verify the absence of cyclonic flow.
- Complete a preliminary velocity and temperature profile and select a nozzle(s).
- Estimate the stack gas moisture concentration.

8.2.1 Sampling site location and traverse point determination

Follow the standard procedures in Method 1 to select the appropriate sampling site. Choose a location that maximizes the distance from upstream and downstream flow disturbances.

The required maximum number of total traverse points at any location is 12, as shown in Figure 7 of Section 17 of Method 1 of Appendix A-1 to Part 60). You must prevent the disturbance and capture of any solids accumulated on the inner wall surfaces by maintaining a 1-inch distance from the stack wall (0.5 inch for sampling locations less than 36.4 inches in diameter with the pitot tube and 32.4 inches without the pitot tube). During sampling, when the PM_{2.5} cyclone is used without the PM₁₀, traverse points closest to the stack walls may not be reached because the inlet to a PM_{2.5} cyclone is located approximately 2.75 inches from the end of the cyclone. For these cases, you may collect samples using the procedures in Section 11.3.2.2 of Method 1 of appendix A-3 to part 60. You must use the traverse point closest to the unreachable sampling points as replacement for the unreachable points. You must extend the sampling time at the replacement sampling point to include the duration of the unreachable traverse points.

If a duct or stack is round with two or four ports located 90 degrees apart, use six sampling points on each diameter. Use a three by four sampling point layout for rectangular ducts or stacks.

You must determine if the sampling ports can accommodate the in-stack cyclones used in this method. You may need larger diameter sampling ports than those used by Method 5 of appendix A-4 to part 60 or Method 17 of appendix A-6 to part 60 for total filterable particulate sampling. When you are using only the PM_{2.5} cyclone (cyclone IV), you may use 10-cm (4 inch) diameter sampling ports if the ports are clean. If the PM₁₀ cyclone is used and the nozzles are smaller than 4.1 mm (0.16 inches) in diameter, the sampling port diameter must be at least 15 cm (6 inches) since the nozzle-cyclone assembly will not fit into the conventional 10-cm (4 inch) diameter ports.

When the PM_{2.5} cyclone is used without the PM₁₀ cyclone, traverse points closest to the stack walls may not be reached because the inlet to a PM_{2.5} cyclone is located approximately 70 mm (2.75 inches) from the end of the cyclone. For these cases, you may collect samples using the procedures in Section 11.3.2.2 of Method 1 of Appendix A-1 to Part 60. You must use the traverse point closest to the unreachable sampling points as replacement for the unreachable points. You must extend the sampling time at the replacement sampling point to include the duration of the unreachable traverse points.

8.2.2 Probe/cyclone blockage calculations

Follow the procedures in the next two sections, as appropriate.

8.2.2.1 Ducts with diameters greater than 92 cm (36.4 inches).

Based on commercially available cyclone assemblies for this procedure, ducts with diameters greater than 36.4 inches have blockage effects less than three percent, as illustrated in Figure 7 of Section 17. You must minimize the blockage effects of the combination of the in-stack nozzle/cyclones, Pitot tube, and filter assembly that you use by keeping the cross-sectional area of the assembly at three percent or less of the cross-sectional area of the duct.

8.2.2.2 Ducts with diameters between 65 and 92 cm (25.7 and 36.4 inches).

Ducts with diameters between 65 and 92 cm (25.7 and 36.4 inches) have blockage effects ranging from three to six percent, as illustrated in Figure 7 of Section 17. Therefore, when you conduct tests on these small ducts, you must adjust the observed velocity pressures for the estimated blockage factor whenever the combined sampling apparatus blocks more than three percent of the stack or duct (see Sections 8.6.4.2 and 8.6.4.3 on the probe blockage factor and the final adjusted velocity pressure, respectively).

NOTE: Valid sampling with the combined PM_{2.5}/PM₁₀ cyclones/filter sampling head and Pitot tube cannot be performed with this method if the average stack blockage from the sampling assembly is greater than six percent, i.e., the stack diameter is less than 67 mm (26.5 inches).

8.2.3 Cyclonic flow check

This method is not recommended for sampling locations that have cyclonic flow conditions. You must follow Method 1 of Appendix A-1 to Part 60 to determine the presence or absence of cyclonic flow.

You do this by inserting the S-type pitot tube into the stack and at each of the traverse points rotate the pitot tube until you locate the angle that has a null (zero) velocity pressure. Record the angles and calculate the average of the absolute values of the null velocity pressure angles. Cyclonic flow is present if the average absolute value exceeds 20 degrees.

8.2.4 Preliminary velocity and temperature profile

Conduct a preliminary velocity and temperature traverse by following Method 2 of Appendix A-2 to Part 60 velocity traverse procedures. The purpose of the velocity profile is to determine all of the following:

- The sample gas flow rate for the combined probe/cyclone sampling head needed to meet the required cyclone particle size cutoff diameter;
- The appropriate nozzle(s) to maintain isokinetic ratio within the acceptable range over the measured velocity pressure and temperature range for the average sample gas flow rate required to achieve the target sample volume. If the isokinetic range cannot be met (e.g., batch processes, extreme process flow or temperature variation), void the sample or use methods to correct the data. The acceptable variation from isokinetic sampling is 80 to 120 percent and no more than 100 ± 21 percent (2 out of 12 or 5 out of 24) of the sampling points outside of this criterion; and
- The necessary sampling duration to obtain sufficient particulate catch weights.

8.2.4.1 Preliminary traverse

You must use an S-type pitot tube with a thermocouple to conduct the preliminary traverse. Conduct the preliminary traverse as close as possible to the anticipated testing time on sources that are subject to hour-by-hour gas flow rate variations greater than approximately ± 20 percent and/or gas temperature variations greater than approximately ± 28 °C (± 50 °F).

***NOTE:** You should be aware that these variations can cause errors in the cyclone cut diameters and the isokinetic sampling rates.*

8.2.4.2 Velocity pressure range and temperature

Insert the S-type Pitot tube into the stack and record the velocity pressure and temperature measured at each traverse point. You will use this later to select the appropriate nozzles(s).

8.2.4.3 Initial gas stream viscosity and molecular weight

Calculate the average stack gas temperature; estimate the stack gas oxygen, carbon dioxide, and moisture concentrations. You will use this information to calculate the initial gas stream viscosity (Equation 3) and molecular weight (Equations 1 and 2).

***NOTE:** For these initial calculations, you must either assume a moisture concentration (based on prior knowledge of the process); estimate moisture following the procedures outlined in Method 4 (Reference 7) or use a wet bulb-dry bulb measurement device or a hand-held hygrometer measurement device for stack gas temperatures less than 71 °C (160 °F).*

8.2.5 Particulate matter concentration in the gas stream

Determine the particulate matter concentration in the gas stream through qualitative measurements or estimates based on previous measurements. Having an idea of what the particulate matter concentration is in the gas stream will help you determine the appropriate test run duration necessary to acquire a mass of particulate matter at least five times greater than the method detection level (see section 8.3.8) for the sample filters.

8.2.6 Estimate stack gas moisture

Estimate the moisture concentration of the stack gas using historical data, EPA Method 4 (approximation method or its alternatives) or other techniques.

8.2.7 Stack gas pressure (absolute)

Determine the stack gas pressure using the barometric pressure and measured stack gas static gauge pressure.

8.3 Pre-test calculations

You must perform various pre-test calculations to calculate the appropriate sample gas flow rate through cyclone I (PM₁₀) and cyclone IV (PM_{2.5}), to select the most appropriate size nozzle(s), and to set the minimum-maximum velocity criteria. Calculating the appropriate sample gas flow rate will allow you to meet the particle cut size specification for each cyclone as listed in Table 2 of Section 17. The appropriate sample gas flow rate is defined by the performance curves for both cyclones, as illustrated in Figure 8 of Section 17. The optimum sample gas flow rate is the overlap zone defined as the range below the 2.25 µm curve of cyclone IV down to the 11.0 µm curve of cyclone I (area between the two dark, solid lines in Figure 8 of Section 17).

You must calculate a sample gas flow rate in the middle of the overlap zone to maximize the acceptable tolerance for slight variations in flow characteristics at the sampling location. The overlap zone is also a weak function of the gas composition.

[NOTE: You should be aware that the acceptable range is limited, especially for gas streams with temperatures less than approximately 38 °C (100 °F).]

You must perform the calculations listed below and the calculations described in paragraphs 8.3.1 through 8.3.7 of this section.

If you are using...	To calculate...	Then use...
Preliminary data	dry stack gas molecular weight, M_{ds}	Equation 1
Dry gas molecular weight (M_d) and preliminary moisture concentrations in the gas streams	wet stack and sample gas molecular weights, M_{w1} and M_w	Equation 2 ¹
Stack gas temperature, oxygen and preliminary moisture concentrations in the gas stream	gas viscosity, μ	Equation 3
Barometric pressure and average static (gauge) stack gas pressure	stack gas pressure (absolute), P_s	Equation 4
Gas viscosity, μ	Cunningham correction factor ² , C	Equation 5
Assumed Reynolds number ³ (N_{re}) $N_{re} < 3162$	preliminary lower limit cut diameter for cyclone I, D_{50LL}	Equation 6
D_{50LL} from Equation 6	cut diameter for cyclone I for middle of the overlap zone, D_{50T}	Equation 7
D_{50T} from Equation 7	final sample gas flow rate for cyclone I, Q_I (Q_s)	Equation 8
Q_I (Q_s) from Equation 8	(verify) the assumed Reynolds number	Equation 9

¹ Use prior stack test results or use Method 4 of Appendix A to 40 CFR Part 60 to estimate the moisture concentration the stack gas before the test. You may use a wet bulb-dry bulb measurement device or hand-held hygrometer to estimate moisture concentration in sources with gas temperature less than 160°F.

² For the lower cut diameter of cyclone IV, 2.25 micrometer.

³ Verify the assumed Reynolds number using paragraph 8.3.1, below, before proceeding to Equation 12.

If you are using...	To calculate...	Then use...
Assumed Reynolds number ³ (N_{re}) $N_{re} \geq 3162$	lower limit cut diameter for cyclone I, D_{50LL}	Equation 10
Q_s from Equation 8 and estimated stack moisture concentration	estimated sample gas flow rate through cyclones I and IV (at standard conditions, dry basis), $Q_{st(std)}$	Equation 11
$Q_{st(std)}$ from Equation 11	estimated dilution air flow rate (at standard conditions, dry basis), $Q_{2(std),t}$	Equation 12
Sample gas flow rate through cyclones I and IV (Q_s); stack gas pressure and temperature; and estimated molecular weight, temperature and pressure at the sample venturi	target sample venturi pressure differential setting, ΔH_1	Equation 13
Dilution air flow rate ($Q_{2(std),t}$) and estimated molecular weight, air temperature and pressure at the dilution air venturi	target dilution air venturi pressure differential setting, ΔH_2	Equation 14
Use preliminary data to calculate initial stack gas velocity (v_s)	velocity of stack gas (v_s)	Equation 15
Use Equations 16, 17, and 18 to recalculate v_s for C_p and probe blockage (b_r) prior to calculating the nozzle diameter for the acceptable sample gas flow rate	adjusted velocity of stack gas (v_s)	Equations 16, 17, and 18 (adjusted)
Sample gas flow rate through cyclones (Q_s) and adjusted stack gas velocity (v_s)	nozzle diameter for acceptable sample gas flow rate (D_n)	Equation 19
Nozzle diameter (D_n)	nozzle area (A_n)	Equation 20
Sample gas flow rate through cyclones (Q_s) and nozzle diameter (D_n)	sample gas velocity in nozzle (v_n)	Equation 21
Gas viscosity (μ), sample gas flow rate through cyclones (Q_s), and nozzle velocity (v_n)	minimum (R_{min}) and maximum (R_{max}) nozzle/stack velocity ratio parameter to maintain isokinetic range of 80 to 120 percent.	Equations 22 and 23
Nozzle velocity calculated in Equation 21 and R_{min}	minimum stack gas velocity (v_{min}) if R_{min} (Equation 22) is an imaginary number (value under the square root function is negative) or less than 0.5	Equation 24
	or	
	minimum stack gas velocity (v_{min}) if R_{min} (Equation 22) is greater than 0.5	Equation 25
Nozzle velocity calculated in Equation 21 and R_{max}	maximum stack gas velocity (v_{max}) if R_{max} is equal to or less than 1.5	Equation 26
	or	

If you are using...	To calculate...	Then use...
	maximum stack gas velocity (v_{\max}) if R_{\max} is greater than 1.5	Equation 27
Preliminary data (i.e., P_s , T_s , and M_w), C_p , and v_{\min}	minimum stack gas velocity pressure (Δp_{\min}) which will maintain an isokinetic range of 80 percent to 120 percent	Equation 28
Preliminary data (i.e., P_s , T_s , and M_w), C_p , and v_{\max}	maximum stack gas velocity pressure (Δp_{\max}) which will maintain an isokinetic range of 80 percent to 120 percent	Equation 29
Preliminary traverse data ($\Delta p'$), number of traverse points (N), and total run time (t_r)	sample gas flow time at point 1 (t_1) rounded to the nearest ¼ minutes (15 seconds).	Equation 30
Historical field train proof blank results	Estimated method quantifiable levels	Equations 67 to 71
Estimated method quantifiable levels	Minimum test run duration	Equation 72
Estimated mixed gas moisture fraction	Estimated mixed gas dew point	Equation 65

8.3.1 Verify Reynolds number

Verify the assumed Reynolds number (N_{re}) by substituting the sample gas flow rate (Q_s) calculated in Equation 8 into Equation 9. Then use the following procedures to determine if the N_{re} used in Equation 6 was correct.

If the N_{re} is ...	Then ...	And ...
< 3162	Calculate ΔH_1 for the sample venturi	
\geq 3162	Recalculate D_{50LL} using Equation 10	Substitute the "new" D_{50LL} into Equation 7 to recalculate D_{50T}

8.3.2 Final sample gas flow rate

You must recalculate the final sample gas flow rate (Q_s) if the assumed Reynold's number used in your initial calculation is not correct. Use Equation 8 to recalculate the optimum sample gas flow rate (Q_s).

8.3.3 Dilution air supply rate

You should use a dilution ratio in the range of at least 10 (minimum) up to 40 to achieve near ambient conditions in the diluted stack gas sample. The appropriate dilution ratio will allow you to cool the stack gas sample to 29 °C (85 °F) or lower while avoiding water vapor condensation. You must calculate using Equation 12 the rate of dilution air required to achieve the desired dilution ratio to keep water vapor condensation from occurring in the mixing cone or mixing chamber. Select the lowest dilution ratio of 10 or higher commensurate with avoiding water condensation and achieving

detection limit objectives. You must not use a dilution ratio of 40 or greater as this may inhibit CPM formation that may otherwise be present in the emissions as they reach ambient conditions.

NOTE: *If condensation is observed after a test, the external heaters should be checked to assure that surface temperatures of the mixing cone holder, mixing tube and filter holders are maintained above the water dew point. If the surface temperatures are acceptable, the relative humidity of the dilution air should be decreased and/or the dilution ratio should be increased.*

8.3.4 Sample venturi pressure setting

Use Equation 13 to calculate the sample venturi pressure setting (ΔH_1) after you calculate the optimum sample gas flow rate and confirm the Reynolds number.

NOTE: *The stack gas temperature may vary during the test which will affect the actual sample gas flow rate through the cyclones. If this occurs, you must make slight adjustments to the blower controls to achieve the sample venturi ΔH_1 to maintain the correct cyclone cut diameters. Therefore, use Equation 13 to recalculate the ΔH_1 values for 28 °C (50 °F) above and below the stack temperature measured during the preliminary traverse. You may document the information on a form similar to Table 3 in Section 17. These calculations may be embedded in the DACS for control purposes.*

8.3.5 Dilution air venturi pressure setting

Use Equation 14 to calculate the dilution air venturi ΔH_2 after you calculate the optimum dilution air supply rate based on the desired dilution ratio.

8.3.6 Choosing a sampling nozzle

You must select one or more nozzle sizes to provide for near isokinetic sample gas flow rates (that is, 80 percent to 120 percent). This will also minimize any isokinetic sampling errors for the 10 μm and 2.5 μm particles at each point. First calculate the mean stack gas velocity, v_s , using Equation 15. Look at Section 8.6.3 for information on correcting for blockage and use of different Pitot tube coefficients. Then use Equation 19 to calculate the diameter of a nozzle that provides for isokinetic sampling at the mean stack gas velocity at flow Q_s . From the available nozzles just smaller and just larger than this diameter, D , select the most promising nozzle(s). Perform the following steps for the selected nozzle(s).

8.3.6.1 Nozzle area

Calculate the nozzle opening cross-sectional area using Equation 20.

8.3.6.2 Velocity of gas in nozzle

Calculate the velocity of the gases entering the nozzle using Equation 21.

8.3.6.3 Minimum/maximum nozzle/stack velocity ratio

Use Equation 22 to calculate the minimum nozzle/stack velocity ratio, R_{\min} . Use Equation 23 to calculate the maximum nozzle/stack velocity ratio, R_{\max} .

8.3.6.4 Minimum gas velocity

Use Equation 24 to calculate the minimum gas velocity (v_{\min}) if R_{\min} is an imaginary number (negative value under the square root function) or if R_{\min} is less than 0.5. Use Equation 25 to calculate v_{\min} if R_{\min} is greater than or equal to 0.5.

8.3.6.5 Maximum gas velocity

Use Equation 26 to calculate the maximum stack velocity (v_{\max}) if R_{\max} is less than 1.5. Use Equation 27 to calculate the gas velocity if R_{\max} is greater than or equal to 1.5.

8.3.6.6 Conversion of gas velocities to velocity pressure

Use Equation 28 to convert v_{\min} to minimum velocity pressure, Δp_{\min} . Use Equation 29 to convert v_{\max} to maximum velocity pressure, Δp_{\max} .

8.3.6.7 Comparison of minimum and maximum velocity pressures

Compare minimum and maximum velocity pressures with the observed velocity pressures at all traverse points during the test (see section 8.2.4.1 of this section).

8.3.7 Optimum sampling nozzle

The nozzle you selected is appropriate if all the observed velocity pressures during the preliminary test fall within the range of the Δp_{\min} and Δp_{\max} .

Choose an optimum nozzle that provides for isokinetic sampling conditions as close to 100 percent as possible. This is prudent because even if there are slight variations in the gas flow rate, gas temperature, or gas composition during the actual test, you have the maximum potential of satisfying the isokinetic criteria. Generally, one of the two candidate nozzles selected will be closer to optimum (see Section 8.3.6).

When testing is for $PM_{2.5}$ only, you can only have two traverse points that are outside the range of the Δp_{\min} and Δp_{\max} . If the coarse fraction for PM_{10} determination is included, only one traverse point can fall outside the minimum-maximum velocity pressure range. However, you can select two or more nozzles so that the traverse points will be within the criteria calculated for each nozzle.

Visually check the selected nozzle for damage before use and replace it if it is damaged. Apply PTFE tape to the nozzle threads, being careful to avoid applying tape beyond the threaded area at the nozzle exit. Screw the pre-selected nozzle into the main body of the cyclone. If you are using both cyclones, connect the cyclone IV inlet to the outlet of cyclone I (see Figure 3 of Section 17).

8.3.8 Estimated method detection level

You must determine the estimated method detection level based on at least seven field train proof blanks. Calculate the estimated method detection limit for each sample fraction (47 mm filters, acetone recovery rinses, water recovery rinse) following equations 67 and 68 in section 12 of this method.

If seven sets of field train proof blank results are not available (e.g., if you are using this test for the first few times), you may collect seven field train proof blanks from a location other than a source location. This may not replicate all sources of measurement error that occur at a source location. However, as field train proof blanks are collected at source locations with each test, you must use the seven most recent field train proof blanks for establishing method detection limits. You may establish general method detection limits based on at least four independent sets of seven field train proof blanks. You must update general method levels at least annually or when any field train proof blank exceeds the current general method level.

8.3.9 Minimum test run duration

You must determine the minimum test run duration necessary to assure that the method detection level is no more than 20 percent of the applicable regulatory limit or action level for the intended use of the data. Calculate the minimum test run duration following equation 72 in section 12 of this method.

NOTE: *The minimum test run duration generally should not be less than 60 minutes to assure a representative sample.*

8.4 Sampling train assembly

First, you must assemble the train and then leak check the train from the cyclone nozzle tip; if necessary, perform a separate leak check on the diluted section of the train (mixing cone, mixing chamber, filter). Leak check the dilution and sample venturi pressure lines; leak check the pitot tubes following Section 8.1 of EPA Method 2. Use the following procedures to prepare as much of the sampling train as possible in a controlled environment.

NOTE: Do not contaminate the sampling train during preparation and assembly. You must keep all openings where contamination can occur covered until just prior to assembly or until sampling is about to begin.

8.4.1 Sampling head.

Assemble the cyclone sampling head using one or both of the PM₁₀ and PM_{2.5} cyclones, depending on the test objectives. Install seal rings of the appropriate material based on the stack gas temperature as specified in Section 6.1.1.1.

You must keep the nozzle covered to protect it from nicks and scratches and keep all openings where contamination can occur covered until just prior to assembly or until sampling is about to begin.

8.4.2 Exhaust filter and filter holder.

Use tweezers or clean disposable surgical gloves to place a pre-weighed filter on the filter support screen of the filter holder. You must center the filter so that the sample gas stream will not circumvent the filter. After placing the O-ring on the holder correctly, join the two filter holder halves by placing the front half (or inlet) filter holder on top of the filter and back half filter holder. Clamp the two filter holder halves together using the 6 inch sanitary flange clamp.

NOTE: Placing PTFE tape around the circumference of the joint prior to clamping may be effective in reducing leak rate, if necessary.

8.4.3 Mixing chamber and exhaust filter holder.

Place the mixing chamber exit flange on the filter holder inlet flange, making sure the seal ring is properly seated between the two flanges and then place a 4 inch diameter (nominal) stainless steel sanitary clamp over the flanges to complete the seal.

NOTE: Placing PTFE tape around the circumference of the joint prior to clamping may be effective in reducing leak rate, if necessary.

8.4.4 Probe-heated compartment-mixing cone holder.

Insert the sample venturi-cone connector (SVCC) tubing through the tee used to create the annulus space for the preheated dilution air slipstream. Connect the tubing to the mixing cone holder tubing and to the tee. Connect the sample venturi ball fitting to the SVCC socket fitting with a pinch clamp. Attach the inlet socket of the sample venturi to the probe's exit ball fitting with a pinch clamp and secure the probe with the probe holder bracket.

Attach the sanitary flange end of the reducer to the 38 mm (1.5 inch) flange on the mixing cone holder, making sure the gasket seal ring is properly placed between the flanges; use a 38 mm (1.5 inch) clamp to complete the seal. Confirm that the 64 mm (2.5 inch) end of the reducer is capped by a plugged hose coupler (which will be replaced prior to the testing).

8.4.5 Mixing cone, mixing chamber and exhaust filter holder.

Place the mixing cone inside the cone holder as shown in Figure 2. Join the cone holder flange to the mixing chamber flange, making sure the gasket seal ring is correctly located between the two flanges

using a 10 cm (4 inch) diameter (nominal) stainless steel sanitary clamp to complete the seal. Join the sanitary flange end of the filter holder inlet to the mixing chamber exit flange with the Viton® seal ring between and seal with a sanitary flange clamp. Orient the filter holder inlet such that the 38 mm (1.5 inch) sanitary flange fitting outlets are oriented vertically downward when the train is fully assembled. Confirm that the filter holder exit is capped by a plugged hose coupler (which will be replaced prior to the testing). Attach the blanking plates, gaskets and clamps for the 38 mm (1.5 inch) sanitary flange fittings on the exhaust filter holder inlet and tighten the clamps to seal.

Wrap the mixing cone holder, mixing chamber, exhaust filter holder inlet and sample filter holder inlet with non-shedding thermal insulation, electric heating tapes and/or custom-fitted blankets. Attach a thermocouple to the exterior surface of the mixing chamber approximately 2 inches upstream from the filter holder inlet. Do not place the thermocouple directly under the heating tape, if used.

If necessary to maintain surface temperatures above the water dew point and to achieve a mixed gas temperature of 85 °F or lower, insulate these sections with a thermal insulation blanket that will not shed fibers (do not use loose fiber insulation). Reflective thermal insulation also may be effective in maintaining mixed gas temperature of 85 °F or lower when ambient temperatures are high.

8.4.6 Exhaust gas blower.

Connect a flexible hose to the inlet of the exhaust gas blower using a hose coupler. You will attach the other end to the filter holder exit (after removing the plugged coupler) after the probe is inserted into the stack port (after leak checking).

8.4.7 Dehumidifier and dilution air blower.

Connect the dilution air blower inlet to the dehumidifier outlet using flexible hose and sanitary flange hose couplers.

8.4.8 Dilution air particulate filter housing, dilution air blank filter holder tee and dilution air venturi.

- Connect the sample dryer/activated carbon filter outlet to the dilution air blower inlet using sanitary flange fittings;
- Connect the dilution air blower outlet directly to the relative humidity sensor assembly inlet using sanitary flange fittings.
- Connect the relative humidity sensor assembly outlet directly to the dilution air particulate filter housing inlet using sanitary flange fittings.
- Connect the dilution air particulate filter housing outlet to the dilution air blank filter holder tee inlet using sanitary flange fittings.
- Connect the dilution blank filter holder tee outlet directly to the dilution air venturi inlet using sanitary flange fittings.
- Connect one end of a cleaned flexible hose to the outlet of the dilution air venturi using a sanitary flange hose coupler.
- Attach a hose coupler to the opposite end of the cleaned flexible hose and attach a blanking plate and gasket to seal the hose until testing begins. This end will be connected to the mixing cone holder, after the probe is inserted into the stack.
- Attach a blanking plate, gasket and clamp to the filter attachment opening of the dilution air blank filter holder adapter tee and tighten the clamp to seal.

8.4.9 47 mm filter holder assemblies

Loading the 47 mm filters into the filter holders must be performed in a clean area. Put on a new pair of nitrile gloves before loading the 47 mm filter assemblies. For samples and dilution air blanks, remove a 47 mm filter cassette from its protective container and place it in the filter holder assembly. Assemble the top and bottom sections of the filter holder to secure the filter cassette within the assembly. Do not overtighten the filter holder assembly or damage to the filter may result. Record the filter location and test identification code on the protective container or bar code log. Retain the protective containers for sample recovery.

Attach the sample filter to the 38 mm (1.5 inch) sanitary flange fitting on the exhaust filter holder inlet. Attach the 47 mm dilution air blank filter to the dilution air blank tee. Connect the 47 mm filter assembly outlets to the MFM inlet filters. Attach clean blanking plates to any unused 38 mm (1.5 inch) sanitary flange fittings on the exhaust filter inlet.

8.5 Leak Check Procedure

You must conduct pre-test and post-test leak checks of the sampling train. Use the procedures outlined below to leak check the entire sampling system, including pressure lines, sample filters and dilution air supply connections downstream of the dilution air venturi.

8.5.1 Pre-test and post-test leak checks.

A leak check of the undiluted and diluted sections is required. You may leak check both sections together or separately. Each section has a different maximum allowable leak rate:

- 0.7 L/min (0.02 cf/min) for the undiluted section (nozzle to the mixing cone holder outlet including dilution air supply connections downstream of the dilution air venturi);
- 1.4 L/min (0.05 cf/min) for the diluted section (mixing chamber inlet through the exhaust filter holder outlet); and
- 0.7 L/min (0.02 cf/min) for both sections combined (nozzle to the exhaust filter outlet including dilution air supply connections downstream of the dilution air venturi).

Perform the pre-test leak check at a vacuum of 76 mm (3 in.) Hg. Perform the post-test leak check at the highest vacuum observed during the test. You must use a flow meter that is sensitive enough to accurately measure the leak rate, such as a mass flow meter, rotameter or dry gas meter.

8.5.1.1 Undiluted section leak check.

You must plug the sample venturi pressure taps (one way is to connect the two taps with rubber tubing) and the mixing cone holder outlet. A 10 cm (4 inch) blank plate designed for use with sanitary flange fittings works well. Attach the dilution air supply hose (which connects the dilution air venturi outlet to the inlet port of the mixing cone holder) to the dilution air supply inlet port of the mixing cone holder. Connect the leak check adapter to the inlet of the dilution air supply hose. Connect the umbilical line from the pump to the leak check adapter.

Perform the leak check by plugging the nozzle, pulling a vacuum as specified in Section 8.5.1 and observing the leak rate indicated by a flow meter. If the pre-test leak rate exceeds the allowable leak rate specified in Section 8.5.1, determine the source of the leaks, seal them and re-perform the pre-test leak check until the leak rate does not exceed the allowable leak rate. Record the pre-test and post-test leak check results on the field test data sheet for the specific test.

NOTE: Do not conduct a leak check during port changes.

8.5.1.2 Diluted section leak check.

Connect the leak check adapter to the exhaust filter holder outlet. Attach a 47 mm sample filter holder containing the PTFE membrane sample filter for the test onto one of the ports on the exhaust filter holder inlet. Install blank plates and seals in the mixing chamber inlet and in the unused 38-mm (1.5-inch) 47-mm filter ports on the exhaust filter holder inlet. Plug the sample filter holder outlet. Connect the umbilical line from the pump to the leak check adapter.

Perform the leak check by pulling a vacuum as specified in 8.5.1 and observing the flow rate. Slowly release the vacuum at the end of the leak check to avoid damaging the sample filter. If the pre-test leak rate exceeds the allowable leak rate specified in Section 8.5.1, determine the source of the leaks, seal them and re-perform the pre-test leak check until the leak rate does not exceed the allowable leak rate. Record the pre-test and post-test leak check results on the field test data sheet for the specific test.

NOTE: Do not conduct a leak check during port changes.

8.5.1.3 Combined diluted and undiluted leak checks

If you are leak checking the diluted and undiluted sections together with the sampling train fully assembled, attach the dilution air supply hose (which connects the dilution air venturi outlet to the inlet port of the mixing cone holder) to the dilution air supply inlet port of the mixing cone holder, attach a 47 mm sample filter holder containing the PTFE membrane sample filter for the test onto one of the ports on the exhaust filter holder inlet, install blank plates and seals in dilution air supply hose inlet and in the unused 38 mm (1.5 inch) sample filter ports on the exhaust filter holder inlet. Install the leak check adapter on the exhaust filter holder outlet. Plug the nozzle.

Perform the leak check by pulling a vacuum as specified in 8.5.1 and observing the flow rate indicated by a flow meter. Slowly release the vacuum at the end of the leak check to avoid damaging the sample filter. If the pre-test leak rate exceeds the allowable leak rate specified in Section 8.5.1, determine the source of the leaks, seal them and re-perform the pre-test leak check until the leak rate does not exceed the allowable leak rate. Record the pre-test and post-test leak check results on the field test data sheet for the specific test.

8.5.2 Pitot tube assembly

You must perform a leak check of the Pitot tube assembly before and after each run. Conduct the leak check as follows: (1) blow through the pitot impact opening until at least 7.6 cm of water column (3.0 iwc) pressure registers on the manometer; then, close off the impact opening. The pressure shall remain stable for at least 15 seconds; (2) do the same for the static pressure side, except using suction to obtain the minimum of 7.6 cm of water column (3.0 iwc) pressure. Record the leak check results on a data sheet for the specific test.

NOTE: You may use a plastic syringe connected to the impact or static opening with flexible tubing to pressurize the Pitot tube assembly.

8.5.3 Venturi pressure lines

You must perform a leak check of the sample and dilution air venturi pressure lines. Conduct a pre-test leak check as follows for each venturi: (1) blow through the positive pressure line until at least 76 mm (3 inches) of water column pressure registers on the manometer or pressure transducer display; then, close off the tubing. The pressure shall remain stable for at least 15 seconds; (2) do the same for the negative or low pressure side, except using suction to obtain the minimum of 76 mm (3.0 inches) of water column pressure. Record the leak check results on a data sheet for the specific test.

8.5.4 47 mm filter holder, MFM, flow control valve, vacuum pump and connecting tubing

Assemble the vacuum pump, flow control valves, MFM and all connecting tubing and connect to the loaded 47 mm filter holders that will be used for the test run. Ensure that the cap on the inlet of the 47 mm filter holder remains intact. Turn on the vacuum pump and adjust the vacuum to 76 mm (3 inches) Hg column. Observe the MFM reading. The flow rate must remain below 0.5 L/min for at least 15 seconds to complete the leak check. When the leak check is complete, slowly release the vacuum before turning off the pump so as not to damage the PTFE membrane filter.

8.5.5 Mixing cone holder, mixing tube, exhaust filter holder and sample filter heaters

Attach heating tapes and/or heating blankets to the exterior of the mixing cone holder, mixing tube, exhaust filter holder and sample filter holders. Attach a temperature sensor to measure the exterior mixing tube surface temperature approximately 5 cm (2 inches) from the exit of the mixing tube. Ensure that all exterior surfaces of these components are protected such that surface temperature is maintained above the mixed gas (diluted sample) water dew point. An insulating blanket may be used to insulate any surfaces not directly in contact with the heating tapes or blankets.

8.6 Sampling system operation

You must maintain nominal cyclone cut sizes of 10 μm and 2.5 μm and keep the isokinetic sampling ratios as close to 100 percent as possible. Maintain the probe and heated compartment temperatures at least 5.6 °C (10 °F) greater than the stack gas temperature to minimize particle deposits in the probe and sample venturi due to thermophoresis.

Maintain the dilution air relative humidity at 50 percent or lower and you must maintain the 47 mm outlet mixed gas temperature and the 142 mm filter exhaust temperature at or below 29 °C (85 °F). For each run, record the site barometric pressure (adjust for elevation); record additional required data at the beginning and end of each time increment (dwell time).

***NOTE:** Stack gas temperature for some source types may be greater than the heating capability of the probe and/or heated compartment. In these instances, operate the probe and heated compartment at the highest practical temperature below the stack gas temperature.*

8.6.1 Cyclone sampling head preheating

You must preheat the cyclone sampling head to within 10 °C (18 °F) of the stack temperature of the gas stream. You must insert the cyclone head-probe assembly into the stack, with the nozzle rotated away from the gas flow direction, for 15 to 40 minutes depending on the time required to achieve the required temperature. You must preheat the probe and the sample venturi compartment to at least 5.6 °C (10 °F) higher than the stack gas temperature (see note in Section 8.6).

8.6.2 Mixing cone holder, mixing tube, exhaust filter holder inlet and sample filter holder assembly preheating

Cool ambient temperatures may lead to surface temperatures in the mixing cone, mixing chamber and filter holder sections to fall below the water dew point of the diluted sample, resulting in water condensation within the sampler. This may occur even though the relative humidity of the diluted sample is less than 100 percent. Water condensation in the sampler will interfere with sample collection. To prevent condensation from occurring, you must also preheat and maintain the surface temperature of the mixing cone holder, mixing chamber, exhaust filter holder inlet and sample filter holder assemblies at a temperature above the water dew point of the diluted sample or sufficient to avoid water condensation, but less than 29 °C (85 °F) to avoid heating the diluted stack gas above

the maximum filter temperature. Use the electric heating tapes and/or heating blankets for this purpose.

NOTE: The water vapor saturation temperature can be calculated using correlations or determined from psychrometric charts based on the diluted sample temperature and relative humidity or using an equation derived from Equation 62 in Section 12 of this method. For example, if the temperature and relative humidity of the diluted sample are 29 °C (85 °F) and 80 percent, respectively, the water vapor saturation temperature would be 26 °C (78 °F). Maintaining the surface temperature between 27 °C and 29 °C (80 °F and 85 °F) should be sufficient in this example. It may be necessary to conduct a preliminary test run to establish the appropriate temperature.

8.6.3 Sample point dwell time

You must calculate the dwell time (that is, sampling time) for each sampling point to ensure that the overall run provides a velocity-weighted average that is representative of the entire gas stream. Vary the dwell time at each traverse point proportionately with the sample traverse point velocity. Use the Equations 30 and 31 to calculate the dwell time at the first point and at each subsequent point. It is recommended that the number of minutes sampled at each point be rounded to the nearest 15 seconds.

8.6.3.1 Dwell time at first sampling point

Calculate the dwell time for the first point, t_1 , using Equation 30. This becomes the baseline time per point used in calculating the dwell time for the subsequent points. You must use the data from the preliminary traverse. N equals the total number of traverse points to be sampled.

8.6.3.2 Dwell time at remaining sampling points

Calculate the dwell time at each of the remaining traverse points, t_n , using Equation 31. This time you must use the actual test run data and the dwell time calculated for the first point. Each traverse point must have a dwell time of at least two minutes.

8.6.4 Adjusted velocity pressures

When selecting your sampling points using your preliminary velocity traverse data, your preliminary velocity pressures must be adjusted to take into account the increase in velocity due to blockage. Also, you must adjust your preliminary velocity data for differences in Pitot tube coefficients. Use the following instructions to adjust the preliminary velocity pressure.

8.6.4.1 Different pitot tube coefficient

You must use Equation 16 to correct the recorded preliminary velocity pressures if the Pitot tube mounted on the combined cyclone sampling head has a different Pitot tube coefficient than the Pitot tube used during the preliminary velocity traverse (see Section 8.2.4).

8.6.4.2 Probe blockage factor

You must use Equation 17 to calculate an average probe blockage correction factor (b_f) if the diameter of your stack or duct is between 65.3 and 92.5 cm (25.7 and 36.4 inches) for the combined PM_{2.5}/PM₁₀ cyclone/filter sampling head and pitot tube and between 47.8 and 67.3 cm (18.8 and 26.5 inches) for the PM_{2.5} cyclone/filter sampling head and pitot tube. A probe blockage factor is calculated because of the flow blockage caused by the relatively large cross-sectional area of the combined cyclone sampling head, as discussed in Section 8.2.2 and illustrated in Figure 7 of Section 17.

8.6.4.3 Final adjusted velocity pressure

Calculate the final adjusted velocity pressure (Δp_{s2}) using Equation 18.

8.6.5 Sampling system operation

Collect samples as described in Section 4.1.5 of U.S. EPA Method 5 of Appendix A-3 to Part 60, except use the procedures in this section for isokinetic sampling and flow rate adjustment. Maintain the sampling flow rate calculated in Section 8.3.2 throughout the run provided the stack temperature is within 28 °C (50 °F) of the temperature used to calculate ΔH_1 . If stack temperatures vary by more than 28 °C (50 °F), use the appropriate ΔH_1 value calculated in Section 8.3.4. Calculate the dwell time at each traverse point as each point is traversed.

8.6.5.1 Startup

Clean the portholes prior to the test run. This will minimize the chance of collecting deposited material in the nozzle. Confirm that the probe and sample venturi compartment temperatures are at least 5.6 °C (10 °F) above the stack temperature (or maximum practical operating temperature when stack gas temperature is higher than the maximum practical operating temperatures), that the cyclone heads have had sufficient time to preheat and that the entire surface temperature of the mixing cone holder, mixing chamber and filter holder is above the estimated water dew point of the diluted sample.

Just prior to inserting the sample probe into the sample port, start the dilution air blower at a low speed with the exhaust gas blower off, sufficient to slightly pressurize the dilution sampler above the stack pressure, thereby preventing hot undiluted stack gas from entering the sampler and causing water vapor condensation before beginning the test run.

Position the probe at the first sampling point with the nozzle pointing directly into the gas stream. Ensure the probe/pitot tube assembly is leveled. Allow sufficient time to preheat the cyclone assembly.

NOTE: When the probe is in position, seal off the openings around the probe and porthole to minimize stack gas or air leakage into or out of the port.

NOTE: When handling the sampling assembly during port changes and after sample collection, maintain the horizontal orientation of the mixing chamber on a slight incline such that any water vapor condensate, should condensation occur, does not run into the sample filters before they are recovered.

8.6.5.2 Begin sampling

Increase the dilution blower speed until the pressure reading of the dilution air venturi is close to the target ΔH_2 calculated previously for the desired dilution ratio. Then start the exhaust gas blower and adjust the sample gas flow rate by changing the motor control setting of the exhaust gas blower until the pressure reading of the sample venturi is close to the target ΔH_1 calculated previously for the desired particulate cut sizes.

Adjust both blower settings until achieving the desired cyclone cut sizes, dilution ratio and mixed gas exhaust temperature and relative humidity. It is helpful to have an estimate of the motor control settings needed for the target dilution ratio and cut sizes before the test so that the settings may be quickly reached (to minimize the amount of test time not meeting the criteria of the method).

Once the cyclone cut size, dilution ratio and the mixed gas exhaust temperature and relative humidity stabilize at the target conditions, start the test by turning on the 47 mm filter sample pump and opening the flow control valves to start diluted sample and dilution air flows through the sample and dilution air blank filters and set the flow rate through each filter to 25 L/min (0.88 cf/min). The filter flow control valves may be adjusted prior to the start of the test such that the initial flow rate after turning on the pump is near 25 L/min (0.88 cf/min), and such that they may be finely adjusted after setting the exhaust gas and dilution air blowers. Adjust the exhaust gas and dilution air flow rates by changing the motor control settings of the exhaust gas and dilution air blowers until the pressure

reading of the dilution air venturi is close to the target ΔH_1 and ΔH_2 , respectively, calculated previously for the desired sample flow rate and dilution ratio (the DACS may perform this automatically).

NOTE: *The sample venturi will produce a positive pressure differential regardless of flow direction through the sample probe. Flow direction is determined separately by comparing the pressure at the sample venturi inlet and stack pressure, which will differ by the pressure drop through the cyclones and sample probe ("Cyclone dP"). When you initially start the dilution blower prior to inserting the cyclones and sample probe into the stack, the sample venturi will indicate a positive sample flow rate; however, the Cyclone dP will be greater than zero (positive number) indicating air is flowing from the sampler into the stack. Be sure that the Cyclone dP is less than zero (negative number) after starting and adjusting the exhaust gas blower to ensure that stack gas is flowing into the sampler.*

8.6.5.3 Traversing.

You must traverse the stack cross-section, sampling the previously selected points (maximum of 12 points). After the first point, position the nozzle at the next traverse point, measure the velocity pressure, and calculate the dwell time for that point. Do not bump the cyclone nozzle into the stack walls when sampling near the walls or when removing or inserting the probe through the portholes. This will minimize the chance of extracting deposited materials.

During port changes, maintain the horizontal orientation of the mixing chamber on a slight incline such that any water vapor condensate, should condensation occur, runs forward and not into the sample filters.

8.6.5.4 Data recording.

You must either record the data required manually on the field test data sheet for each run or store the data electronically in a data acquisition system (DAS). We recommend that you record field data manually in addition to electronic data recording as a backup in case the electronic data become corrupted or lost. If you record the data on field test data sheets, record the initial data readings. Then take readings at the following times: (1) the beginning and end of each sample time increment, (2) when changes in flow rates are made, and (3) when sampling is halted. You must record all field data needed to calculate sample results and document that sampling conditions conform to the specifications of this method.

Compare the velocity pressure measurements (Equations 28 and 29) with the velocity pressure measured during the preliminary traverse. Keep the sample venturi ΔH_1 at the value calculated in Section 8.3.4 for the stack temperature that is observed during the test. Keep the dilution air venturi ΔH_2 at the value calculated in Section 8.3.5. Record all the point-by-point data and other source test parameters on the field test data sheet. Maintain the flow through the sampling system until the last traverse point is sampled. Do not leak check the sampling system during port changes.

8.6.5.5 End of run procedure

To avoid water condensation in the sampler at the end of the run, you must follow this procedure. First close the flow control valves for the the 47 mm filters and record the time of day (this defines the end of the test run) and turn off the sample pump. Then turn off the exhaust gas blower and reduce the dilution air blower speed such that the Cyclone dP changes to a slightly positive value to purge diluted sample from the sampling assembly. Do not turn off the dilution blower. Remove the sampling assembly from the stack. Then turn off the dilution air blower.

Depending on the flexible hose lengths and platform geometry, it may be necessary for you to disconnect the dilution air supply hose and the exhaust hose from the sampling assembly before the probe can be removed from the stack. If so, be sure to cap or plug the openings.

Use care so that you do not scrape the Pitot tube or the combined sampling head against the port or stack walls. Maintain the horizontal orientation of the mixing chamber on a slight incline such that any water vapor condensate, should condensation occur, does not run into the sample filters. Record the final readings and other test parameters on the field test data sheet. After you stop the gas flow, make sure you keep the cyclone head level to avoid tipping dust from one section of the sampling head to another.

Remove the 47 mm filter holders containing the sample(s) and dilution air blank and cap them to prevent particulate matter from entering the assembly during transfer and sample train recovery. Place clean blanking plates, gaskets and sanitary flange clamps on the 47 mm filter ports and tighten the clamp to seal them.

After cooling and when the probe can be safely handled, wipe off all external surfaces near the cyclone nozzle and cap the inlet to cyclone I. Remove the sampling head from the probe. Cap the nozzle and exit of cyclone IV to prevent particulate matter from entering the assembly.

8.6.5.6 Post-sampling leak check

Perform the post-test leak check of the combined sampling train section as described in Section 8.5.1.3, after removing the combined cyclone head. If the leak rate of the combined sampling train exceeds the allowable leak rate, perform separate leak checks on the diluted and undiluted sections. Enter the results of the leak checks onto the field test data sheet. If the leak rates of the diluted and/or undiluted sampling train sections (without the combined cyclone sampling head) exceed their respective allowable leak rates, the run is invalid and you must repeat it.

8.7 Sample Recovery

Sample recovery rinses involve the quantitative transfer by rinsing (and brushing when required) the sampler surfaces in contact with the sample with acetone to recover particles in the following size fractions: (1) $> 10 \mu\text{m}$, (2) $\leq 10 \mu\text{m}$ but $> 2.5 \mu\text{m}$ (coarse), and (3) $\leq 2.5 \mu\text{m}$. You must use ultra-pure acetone rinse to recover particles from the nozzle, cyclone heads, probe, sample venturi, mixing cone, mixing chamber, and front half of the exhaust filter holder. Sample recovery must take place in a clean environment and not on the stack. Wear clean powderless nitrile disposable gloves at all times while handling samples.

8.7.1 Container No. 1 (acetone recovery rinse - nozzle and cyclone I particulate matter $> 10 \mu\text{m}$)

This particulate size fraction recovery is required only if you are determining total particulate matter including particles $> 10 \mu\text{m}$. Quantitatively recover the (1) particulate matter from the cyclone I cup and acetone rinses of the cyclone I cup, (2) internal surface of the nozzle, and (3) cyclone I internal surfaces, including the inside surface of the down-comer line, into Container No. 1. Seal the container and mark the liquid level on the outside of the container. You must keep any dust found on the outside of cyclone I and cyclone nozzle external surfaces out of the sample by cleaning the outside surfaces prior to opening the components for sample recovery. This container holds particulate matter $> 10 \mu\text{m}$.

8.7.2 Container No. 2 (acetone recovery rinse - cyclones I and IV particulate matter ≤ 10 and $> 2.5 \mu\text{m}$)

This particulate size fraction recovery is required if you are determining PM_{10} . Place in Container No. 2 the solids from the cyclone IV cup and the acetone rinses of the cyclone I turnaround cup (above inner down-comer line), cyclone I exit tube, and cyclone IV excluding the exit tube interior surface. Seal the container and mark the liquid level on the outside of the container. This container holds "coarse" particulate matter (≤ 10 and $> 2.5 \mu\text{m}$).

8.7.3 Container No. 3 (water recovery rinse - mixing cone, mixing chamber, and filter holder inlet particulate matter $\leq 2.5 \mu\text{m}$)

Rinse with DI water and recover the interior surfaces exposed to the sample gas in Container No. 3. Specific components are the mixing cone, mixing chamber, and the front half (inlet) of the filter holder. Seal the container and mark the liquid level on the outside of the container. This container holds particulate matter that is $2.5 \mu\text{m}$ and smaller.

8.7.4 Container No. 4A (acetone recovery rinse - cyclone IV, probe and sample venturi particulate matter $\leq 2.5 \mu\text{m}$)

Rinse with acetone, brush, and recover all the interior surfaces exposed to the sample gas in Container No. 4. This will consist of rinses from the exit tube of cyclone IV, probe, sample venturi, and sample venturi cone connector. Seal the container and mark the liquid level on the outside of the container. This container holds particulate matter that is $2.5 \mu\text{m}$ and smaller.

8.7.5 Container No. 4B (acetone recovery rinse - mixing cone, mixing chamber, and exhaust filter holder inlet particulate matter $\leq 2.5 \mu\text{m}$)

Rinse with acetone, brush, and recover all the interior surfaces exposed to the sample gas in Container No. 4. This will include all components from the exit tube of cyclone IV up to and including the exhaust filter holder inlet. Specific components are the exit tube of cyclone IV, probe, sample venturi, and sample venturi cone connector; after the DI water rinse, rinse the mixing cone, mixing chamber, and the front half (inlet) of the exhaust filter holder with acetone. Seal the container and mark the liquid level on the outside of the container. This container holds particulate matter that is $2.5 \mu\text{m}$ and smaller.

8.7.6 Container No. 5 (not used)

8.7.7 Container No. 6 (acetone recovery rinse blank)

Take 200 ml of the acetone directly from the wash bottle you used, and place it in Container No. 6, labeled Acetone Recovery Rinse Blank.

8.7.8 Container No. 7 (DI water recovery rinse blank)

Take 200 ml of the DI water directly from the wash bottle you used, and place it in Container No. 7, labeled DI Water Recovery Rinse Blank.

8.7.9 Sample filters

Recover the sample filter cassettes in a very clean recovery area that is totally enclosed and free from suspended dust. Ideally, the recovery area also should be supplied with filtered ventilation and temperature controlled. Recovery work benches should be completely covered in new lint-free laboratory paper before the start of each test program. Restrict foot traffic in and out of the sample recovery area whenever samples are exposed.

8.7.9.1 Container No. 8 (47 mm sample filter)

Remove the sample filter cassette from the sample filter holder and place the cassette into its original labeled and numbered protective container. Never directly handle the filter membrane.

8.7.9.2 Container No. 9 (47 mm dilution air blank filter)

Remove the dilution air blank filter cassette from the dilution air blank filter holder and place the cassette into its original labeled and numbered protective container. Never directly handle the filter membrane.

8.8 Sample transport and storage

During storage and transport to the laboratory, the 47 mm filters with cassettes should be placed in their original labeled and numbered protective containers. Place the filter protective containers in sealable plastic freezer bags.

The sealed plastic bags containing the 47 mm filter samples, accompanied by the completed chain of custody record, can be packed in an insulated protective container (a cooler for example) with as many containers of frozen ice substitute as needed to keep the samples at the specified temperatures.

You must store and transport the 47-mm filter and the acetone and water recovery rinse samples at a temperature of 27°C (80°F) or lower if the samples will be analyzed within 10 days after sample collection. If the samples will be analyzed within 10 to 30 days after sample collection, you must store and transport the samples at a temperature of between 0°C (32°F) and 4°C (39°F) (do not freeze).

The temperature inside the transport container may be monitored and recorded with a maximum/minimum thermometer or other indicator of temperature. See reference 11 in Section 16 of this method for additional guidance on transport of cooled filters.

Package and handle the samples in a manner that reduces vibrations that may dislodge particles from the filters or cause breakage of the rinse containers. Upon arrival at the laboratory, the samples must be stored at the same temperatures specified above until they are conditioned and analyzed.

9. QUALITY CONTROL

9.1 Daily audits

Conduct daily quality audits using data quality indicators that require review of (1) recording and transfer of raw data, (2) calculations, and (3) documentation of testing procedures.

9.2 Calculations

Verify the calculations by independent, manual checks using the equations found in Section 12. You must flag any suspect data and identify the nature of the problem and potential effect on data quality. After you complete the test, prepare a data summary and compile all the calculations and raw data sheets.

9.3 Operating conditions

You must record any unusual process operating conditions or adverse weather conditions that occur during testing. Discontinue the test if the operating conditions may cause non-representative particulate emissions.

9.4 Samples

9.4.1 Sample handling procedures

Because the samples are collected at temperatures of <29 °C (85 °F) or lower, you must take precautions to keep the samples from experiencing temperatures higher than the filtration temperatures. Higher temperatures may cause partial loss of volatile particulate matter components.

You must document the custody transfer of the samples on chain of custody forms. Include enough coolant packages or other cooling means in the transport container to maintain samples at the temperatures specified in section 8.8 of this method. Transport the samples in the transport container to the laboratory expeditiously.

9.4.2 Recovery rinse sample handling procedures

You must document custody transfer of the recovery rinse samples on chain of custody forms. Package the recovery rinse sample containers in a manner to prevent breakage during transport and

store at temperatures specified in Section 8.8 of this method until analysis. Promptly transport the recovery rinse containers to the laboratory in the transport container.

Upon arrival at the lab, verify that no leakage of samples from the containers has occurred.

9.4.3 47 mm filter handling procedures

You must store and transport the sample and dilution air blank 47 mm filter cassettes in their protective containers sealed in plastic sealable bags at temperatures specified in Section 8.8 of this method until analysis. You must document custody transfer of the samples on chain of custody forms. Include enough coolant packages or other cooling means in the transport container to maintain filters at the temperatures specified in section 8.8 of this method. Transport the filters in the transport container to the laboratory expeditiously.

9.5 What blanks must I collect and analyze?

9.5.1 Water and acetone recovery rinse blanks

For each test, you must collect and analyze at least one water recovery rinse blank and one acetone recovery rinse blank as specified in section 8.7 of this method for each lot of reagent used during the tests. You must use these blank results to calculate the final test results.

9.5.2 Field train proof blanks

For each source unit tested, you must collect and analyze at least one field train proof blank (FTPB). Use approximately the same volumes of acetone and water for FTPB recovery rinses as used for sample recovery rinses. FTPBs include all sources of random measurement error (imprecision) and systematic measurement error (bias) within the measurement process except those associated with extracting stack gas samples. You will use replicate FTPB results to establish method detection levels.

You must collect one FTPB prior to the first test run for each source unit that will be tested. Optionally, you may collect additional FTPBs after the first or second test run.

You must analyze all FTPB sample fractions for liquid total weights and for liquid and filter net weights and report the results in the test report.

9.5.3 Dilution air blanks

You must collect one dilution air blank for every test run. You must analyze all dilution air blanks and report the results in the test report.

If a dilution air blank filter net weight exceeds the method quantifiable level for 47 mm filters and if it is lower than the corresponding 47 mm filter sample result, adjusted for the volume of gas passed through the filters and dilution air and raw stack gas sample volumes, you will correct the sample result for the dilution air blank net weight (see Section 12).

10. CALIBRATION AND STANDARDIZATION

[NOTE: Maintain a laboratory log of all calibrations. All calibrations must be performed within six months of a test.]

10.1 Gas flow velocities

You must use an S-type pitot tube that meets requirements specified in EPA Publication 600/4-77-027b for making velocity measurements (see Reference 11 in section 16 of this method). You must also:

- Visually inspect the S-type Pitot tube before sampling.

- Leak check both legs of the Pitot tube before and after sampling.
- Maintain proper orientation of the S-type Pitot tube while making measurements.

10.1.1 S-type pitot tube orientation

The S-type Pitot tube is oriented properly when the yaw and the pitch axis are 90 degrees to the stack axis.

10.1.2 Average velocity pressure record

Instead of recording either high or low values, record the average velocity pressure observed at each point during flow measurements.

10.1.3 Pitot tube coefficient

You may either determine the pitot tube coefficient based on physical measurement techniques described in Section 10.1 of EPA Method 2 of Appendix A-2 to Part 60 or by determining a calibrating the s-type pitot according to Section 10.1.3 of EPA Method 2 of Appendix A-2 to Part 60. When calibrating, you must calibrate the pitot tube using the sampling head because of potential interferences from the cyclone body.

10.2 Thermocouple calibration

You must use the procedures described in paragraph 10.3 of EPA Method 2 of Appendix A-2 to Part 60 to calibrate the temperature measurement system.

10.3 Nozzles

Use electropolished stainless steel nozzles for isokinetic sampling. Make sure that all nozzles are thoroughly cleaned, visually inspected, and calibrated according to the procedure outlined in paragraph 10.1 of Method 5 of Appendix A-5 to Part 60.

10.4 Venturis

You must calibrate each venturi over the expected range of flow rates to be encountered. For the sample venturi, this will be approximately 9.9 to 13 standard L/min (0.35 to 0.45 standard cf/min) or 9.9 to 28 actual L/min (0.35 to 1.0 actual cf/min) at stack temperatures; for the dilution air venturi, this will be approximately 10 to 57 actual L/min (3.6 to 20 actual cf/min). Each venturi should be fabricated so that the typical pressure differentials are in the optimal operating range of the devices used to monitor the pressures.

10.4.1 Sample venturi calibration

You must calibrate the sample venturi using procedures described in Appendix B of this method. You must generate a curve of Reynolds number versus flow rate and calculate the coefficients for a flow correlation.

10.4.2 Dilution air venturi calibration

You must calibrate the sample venturi using procedures described in Appendix B of this method. You must generate a curve of Reynolds number versus flow rate and calculate the coefficients for a flow correlation.

10.5 MFM calibration.

Prior to its initial use, the MFMs shall be calibrated. You may calibrate the meter using either a bottled gas containing dry air or the actual diluted stack gas as measured during sampling.

You must perform these calibrations of the MFM using a reference gas flow meter (RGFM). The RGFM may be: (1) a wet test meter calibrated according to Section 10.3.1 of EPA Method 5 of Appendix A-4 to Part 60; (2) a gas flow metering device calibrated at multiple flow rates using the procedures found

in section 16 of EPA Method 5 of Appendix A-4 to Part 60; (3) a NIST-traceable primary volumetric calibration device capable of measuring volumetric flow to an accuracy of 1 percent.

Determine an average calibration factor (Y) for the MFM by calibrating at three sample flow rate settings covering the range of sample flow rates at which the meters will be operated. Concurrently measure the the RGFM and the MFM being calibrated for at least 10 minutes at each of three flow rates covering the typical range of operation of the sampling system. For each set of concurrent measurements, record the total sample volume, in units of dry standard cubic meters (dscm), measured by the RGFM and the gas flow meter being tested. Calculate an individual calibration factor Y_i at each tested flow rate by taking the ratio of the RGFM volume to the sample volume recorded by the MFM. Average the three Y_i values, to determine Y , the calibration factor for the MFM. Each of the three individual values of Y_i must be within ± 0.02 of the average Y .

Check the calibration of the MFM following each field test at one intermediate flow rate setting, either at, or in close proximity to, the average sample flow rate during the field test. If a one-point calibration check shows that the value of Y_i at the tested flow rate differs by more than 5 percent from the current value of Y , repeat the full 3-point calibration procedure to determine a new value of Y , and apply the new Y value to the gas volume measurements made with the MFM during the field test that was just completed.

10.6 Relative humidity transmitters

You may use the manufacturer's recommended procedure for calibrating the RH sensors. Verify the dilution air and mixed gas RH sensor calibrations within three months of each test by attaching the two sensors to each other and drawing ambient air with approximately 50 to 70 percent relative humidity simultaneously through both sensors. Because the difference between the two RH sensors is very important in calculating stack gas moisture concentration using this method, the two RH sensors must agree within 2.8 percent of reading when monitoring the same gas stream.

10.7 Mixing Cone

Prior to use, you must verify the mixing cone's performance to adequately blend the dilution and sample streams in one time laboratory tests.

To perform this evaluation, you must set up the complete OTM-037 sampling train with the exception of the cyclones. Operate the sampler to draw air through the sample probe at a constant sample rate of 25-30 L/min and with a dilution air flow rate of 225-270 L/min (dilution ratio of approximately 10). Add a flow of tracer gas (e.g., propane) to the inlet of the sample probe. Add sufficient tracer gas at a high enough concentration to generate measurable tracer gas concentrations in the exhaust gas after the exhaust filter holder.

Measure tracer gas radial concentration according to the appropriate reference method (e.g. Method 25A) profiles near the exit of the mixing chamber along six points (4.4, 14.6, 29.6, 70.4, 85.4, 95.6 % of diameter), on each of two test ports located 90° apart. Repeat this measurements three times (full traverse three times in succession).

Calculate the average tracer gas concentration at each radial measurement point. The mixer performance is considered acceptable if all of the average radial tracer gas concentrations are 90% to 110% of the fully mixed tracer gas concentration.

11. ANALYTICAL PROCEDURES

11.1 What procedures must I follow to record analytical data?

Record all data on the analytical data sheet. You can obtain the data sheet from Figure 5-6 of U.S. EPA Method 5 (40 CFR 60 Appendix A-3).

11.2 What procedure must I follow for the container analysis?

Follow the analysis procedures outlined below:

11.2.1 Container Nos. 1, 2, 3, 4A, 4B, 6, and 7 (recovery rinse samples, field train proof blanks and wash bottle blanks).

Observe the level of liquid in the container relative to the mark on the container, and record on the analysis sheet whether leakage occurred during transport. If a noticeable amount of leakage has occurred, either void the sample or use methods to correct the final results. Measure the liquid in the container gravimetrically to ± 0.5 g. Quantitatively transfer the contents to a tared beaker with fluoropolymer liner or other non-reactive low mass container for sample weighing, and evaporate to dryness at ambient temperature and pressure. Desiccate for 24 hours, and weigh to a constant weight. Calculate the net weight (final weight less tare weight). Report the results to the nearest 0.01 mg.

11.2.2 Container No. 5 (not used).

11.2.3 Containers No. 8 and 9 (47 mm filters).

Use the following procedures for conditioning and weighing 47 mm filters:

- Filter conditioning. All sample filters used must be conditioned immediately before both the pre- and post-sampling weighings as specified below. See reference 11 in section 16.0 of this method for additional guidance.
 - Mean temperature. 20 to 23 °C.
 - Temperature control. $\pm 2^\circ\text{C}$ over 24 hours.
 - Mean humidity. 30 to 40 percent relative humidity.
 - Humidity control. ± 5 relative humidity percent over 24 hours.
 - Conditioning time. Not less than 24 hours.

NOTE: Generally, condition filters at 30 to 40 percent relative humidity; however, where it can be shown that the mean mixed gas relative humidity during sampling is less than 30 percent, conditioning is permissible at a mean relative humidity within ± 5 relative humidity percent of the mean mixed gas relative humidity during sampling, but not less than 20 percent.

- Weighing procedure.
 - New filters should be placed in the conditioning environment immediately upon arrival and stored there until the pre-sampling weighing. See reference 11 in section 16.0 of this method for additional guidance.
 - The analytical balance must be located in the same controlled environment in which the filters are conditioned. The filters must be weighed immediately following the conditioning period without intermediate or transient exposure to other conditions or environments.
 - Filters must be conditioned at the same conditions (humidity within ± 5 relative humidity percent) before both the pre- and post-sampling weighings.

- Both the pre- and post-sampling weighings should be carried out on the same analytical balance. You must use an effective technique to neutralize static charges on the filter, see reference 11 in section 16.0 of this method. If possible, both weighings should be carried out by the same analyst.
 - The pre-sampling (tare) weighing must be within 30 days of the sampling period.
 - The post-sampling conditioning and weighing must be completed within 30 days after the sample is collected. You must maintain the filter samples at temperatures below the average diluted sample temperature during sampling (or 4 °C) during the time between retrieval from the sampler and the start of the conditioning. Reference 11 in section 16.0 of this method has additional guidance on transport of cooled filters.
- Filter blanks.
 - New field blank filters must be weighed along with the pre-sampling (tare) weighing of each lot of 47 mm filters. These blank filters must be transported to the sampling site, installed in the sampler, retrieved from the sampler without sampling, and reweighed as a quality control check.
 - New laboratory blank filters must be weighed along with the pre-sampling (tare) weighing of each set of 47 mm filters. These laboratory blank filters should remain in the laboratory in protective containers during the field sampling and should be reweighed as a quality control check.

Additional guidance for proper filter weighing and related quality assurance activities is provided in reference 11 in section 16.0 of this method.

Weigh the filters before sample collection. After the filter has been weighed and while still in the filter weighing room, place the filter in a filter cassette and assemble the cassette, then place the cassette in a protective container. The protective container must contain no loose material that could be transferred to the filter. The protective container must hold the filter cassette securely such that the cover shall not come in contact with the filter's surfaces. See Reference 11 in section 16.0 of this method for additional information. Label each protective container with a unique filter identification code or laboratory bar code.

Filters must remain in the filter cassette at all times except during weighing. Do not load filters into or remove filters from filter cassettes in any location except the weighing room. Never directly handle or touch the filter media at any time except during weighing.

12. CALCULATIONS AND DATA ANALYSIS

12.1 Calculations

After the run is completed, you need to perform all of the calculations listed in this section. Also provided are instructions and references for the calculations.

Calculations	Instructions and References
Exhaust gas blower pressure, absolute (P_3)	Use Equation 32
Sample venturi gas pressure, absolute (P_1)	Equation 33

Calculations	Instructions and References
Dilution air venturi air pressure, absolute (P_2)	Equation 34
Moisture fraction of dilution air, dimensionless (B_{W2})	Equation 35
Moisture fraction of mixed gas, dimensionless (B_{W3})	Equation 62
Moisture fraction of stack gas, dimensionless (B_{WS})	Equation 63
Molecular weight of dry stack and sample gas (M_{ds})	Recalculate with Equation 36 using actual dry gas composition data for the run.
Molecular weight of wet stack and sample gas (M_{W1})	Recalculate with Equation 37 using actual moisture data for the run.
Molecular weight of wet dilution air (M_{W2})	Equation 38
Sample gas flow through sample venturi at actual conditions (Q_1)	Equation 39
Sample gas flow rate at stack conditions through cyclones I (Q_S)	Recalculate Q_S with Equation 40 using actual temperatures and pressures measured during run.
Dilution air flow rate at venturi (Q_2)	Equation 41
Dilution air flow rate at dry standard conditions ($Q_{2(std)}$)	Equation 42
Sample gas flow rate through sample venturi at dry standard conditions ($Q_{1(std)}$)	Equation 43
Dilution ratio (DR)	Equation 44
Gas viscosity (μ)	Recalculate viscosity using Equation 3 using actual stack temperature, moisture, and oxygen concentrations.
Actual particle cut diameter for cyclone I (D_{50})	Calculate this using Equation 45 and using the average temperatures and pressures measured during each test run.
Test condition Reynolds number	Use Equation 9 to calculate the actual Reynolds number during test conditions based on: (1) the sample gas flow for the combined cyclone head, (2) the actual gas viscosity for the test, and (3) the dry and wet gas stream molecular weights.
Cunningham correction factor (C_r)	Recalculate the Cunningham correction factor using Equation 48 using actual test run data and a D_p of 2.5.

Calculations	Instructions and References
Particle cut diameter for $N_{re} < 3162$ for cyclone IV (D_{50}) or particle cut diameter for $N_{re} \geq 3162$ for cyclone IV (D_{50}) of 2.5	Depending on the N_{re} value, use Equation 46 or 47 and the recalculated Cunningham factor (C_r) to recalculate the particle cut diameter.
Re-establish cyclone IV D_{50} . (D_{50-1})	Use Equations 49 or 50 to recalculate the particle cut diameter. Use the re-established Cunningham correction factor (calculated in the previous step) and the calculated Reynold's number to determine D_{50-1} .
Establish "Z" values. The "Z" value is the result of an analysis that you must perform to determine if the Cunningham correction factor is acceptable.	Use Equation 51 to establish "Z" values. Compare the calculated cyclone IV D_{50} (either Equation 46 or 47) to the re-established cyclone IV D_{50-1} (either Equation 49 or 50) values based upon the test condition calculated Reynolds number. Acceptable "Z" value is determined by Equation 52.
Volume sampled, dry SCF ($V_{1(std)}$)	Use Equation 53.
Percent isokinetic rate (I)	Calculate this with Equation 54.
Acetone field train proof blank concentration (C_a)	Calculate this with Equation 55.
Water field train proof blank concentration (C_w)	Calculate this with Equation 56.
Acetone field train proof blank weight (W_a)	Calculate this with Equation 57.
Water field train proof blank weight (W_w)	Calculate this with Equation 58.
Precision of sample fraction masses	Equation 66
Method Quantifiable levels	Update using field train proof blank results from latest tests using Equations 67, 68, and 69.
Concentration of $PM_{2.5}$ particulate matter ($C_{PM2.5}$)	Calculate $PM_{2.5}$ concentration with Equation 79 (sample filter).
Concentration of coarse particulate matter < 10 and $\geq 2.5 \mu m$ ($C_{PM10-2.5}$)	Calculate coarse PM concentration with Equation 60.
Concentration of collectible PM_{10} matter (C_{PM10})	Calculate PM_{10} concentration with Equations 61 and 80. Use Equation 80 for low concentrations.

12.1.1 Gas pressure in sampling train.

12.1.1.1 Mixed gas RH sensor gas pressure.

Calculate the mixed gas absolute pressure at the RH sensor (P_3) using Equation 32.

12.1.1.2 Sample venturi gas pressure.

Calculate the sample venturi gas absolute pressure (P_1) using Equation 33.

12.1.1.3 Dilution air venturi air pressure.

Calculate the dilution air venturi air absolute pressure (P_2) using Equation 34.

12.1.1.4 Moisture concentration of dilution air.

Calculate the moisture concentration (B_{W2}) of the dilution air expressed as a decimal fraction using Equation 35.

12.1.2 Molecular weight of stack gas, sample gas, and dilution air.

12.1.2.1 Molecular weight of stack and sample gas, dry.

Recalculate the molecular weight of the stack and sample gas (M_{ds}) using Equation 36 (same as Equation 1). Use the actual dry gas composition data determined for the run using Method 3 or other acceptable method.

12.1.2.2 Molecular weight of stack and sample gas, wet.

Recalculate the wet molecular weight of the stack and sample gas (M_{W1}) using Equation 37. Use the actual stack gas moisture concentration determined for the run using Equation 63 in this method or use another acceptable method.

12.1.2.3 Molecular weight of dilution air, wet.

Calculate the molecular weight of the dilution air (M_{W2}) using Equation 38.

12.1.3 Gas flow rates

12.1.3.1 Sampling flow rate at actual conditions.

Calculate the sampling flow rate through the sample venturi (Q_1) at actual conditions using Equation 39.

12.1.3.2 Sampling flow rate at cyclones.

Calculate the sampling flow rate through the Cyclones (Q_S) at actual conditions using Equation 40.

12.1.3.3 Dilution air flow rate at ambient conditions.

Calculate the dilution air flow rate (Q_2) at ambient conditions using Equation 41.

12.1.3.4 Dilution air flow rate at dry standard conditions.

Calculate the dilution air flow rate ($Q_{2(std)}$) at dry standard conditions using Equation 42.

12.1.3.5 Sample gas flow rate at dry standard conditions.

Calculate the dilution air flow rate ($Q_{2(std)}$) at dry standard conditions using Equation 43.

12.1.4 Dilution ratio.

Calculate the dilution ratio (DR) using Equation 44.

12.1.5 D₅₀ of cyclone IV.

You must analyze D₅₀ of cyclone IV and the concentrations of the particulate matter in the various size ranges. To determine the actual D₅₀ for cyclone IV, you must recalculate the Cunningham correction factor and the Reynolds number for the best estimate of cyclone IV D₅₀. The following paragraphs summarize additional information on how to recalculate the Cunningham correction factor and determine which Reynold's number to use.

12.1.5.1 Cunningham correction factor.

You must recalculate the initial estimate of the Cunningham correction factor using the actual test data. Insert the actual test run data and D₅₀ of 2.5 μm into Equation 48. This will give you a new Cunningham correction factor that is based on actual data.

12.1.5.2 Initial D₅₀ for cyclone IV.

Determine the initial estimate for cyclone IV D₅₀ using the test condition Reynolds number calculated with Equation 9 as indicated in the listing of calculations in Section 12.1. Refer to the following instructions.

- If the Reynold's number is less than 3162, calculate the D₅₀ for cyclone IV with Equation 46, using actual test data.
- If the Reynold's number is equal to or greater than 3162, calculate the D₅₀ for cyclone IV with Equation 47, using actual test data.
- Insert the "new" D₅₀ value calculated by either Equation 46 or 47 into Equation 48 to re-establish the Cunningham Correction Factor (C_r).

[NOTE: Use the cyclone IV Reynolds number calculated for the test condition to determine the most appropriate equation (Equation 46 or 47).]

12.1.5.3 Re-establish cyclone IV D₅₀.

Use the re-established Cunningham correction factor (calculated in the previous step) and the calculated Reynold's number to determine D₅₀₋₁.

- Use Equation 49 to calculate the re-established cyclone IV D₅₀₋₁ if the Reynolds number is less than 3162.
- Use Equation 50 to calculate the re-established cyclone IV D₅₀₋₁ if the Reynolds number is equal to or greater than 3162.

12.1.5.4 Establishing "Z" values

The "Z" value is the result of an analysis that you must perform to determine if the Cunningham correction factor is acceptable. Compare the calculated cyclone IV D₅₀ (either Equation 46 or 47) to the re-established cyclone IV D₅₀₋₁ (either Equation 49 or 50) values based upon the test condition calculated Reynolds number (Equation 51). Follow these procedures:

- Use Equation 51 to calculate the "Z". If the "Z" value is within 0.99 and 1.01, then the D₅₀₋₁ value is the best estimate of the cyclone IV D₅₀ cut diameter for your test run.
- If the "Z" value is greater than 1.01 or less than 0.99, re-establish a Cunningham correction factor based on the D₅₀₋₁ value determined in either Equations 49 or 50, depending upon the test condition Reynolds number.
- Use the second revised Cunningham correction to re-calculate the cyclone IV D₅₀.
- Repeat this iterative process as many times as necessary using the prescribed equations until you achieve the criteria documented in Equation 52.

12.1.6 Particulate concentrations

12.1.6.1 Acetone and Water Recovery Rinse Blank concentrations

Use Equations 55 and 56 to calculate the acetone recovery rinse blank (C_a) and water recovery rinse blank (C_w) concentrations, respectively. These results are used for quality assurance purposes only and do not enter into test result calculations.

12.1.6.2 Acetone and Water Recovery Rinse Sample Masses

Calculate the acetone and water recovery rinse sample masses (m_1 , m_2 , m_3 and m_4) by subtracting the acetone and water rinse field train proof blank net weights from the sample net weights for each corresponding sample fraction. You must not subtract field train proof blank net weights greater than 2.0 mg.

12.1.6.3 NOTE: *In the absence of historical field train proof blank utilizing the procedures found in this method, the default value of 2.0 mg chosen is the same as allowed in Method 202, when Best Practices is implemented. To minimize the systematic bias, EPA suggest you incorporate procedures found in the Method 202 Best Practices (when applicable) to minimize bias. Filter Net Weights*

Determine the net weights of the 47 mm filters used in the tests and in the field train proof blanks.

12.1.6.4 Calculate PM₁₀, Coarse PM and PM_{2.5} Concentrations

Use the following procedures:

- Use Equations 59 and 79 to calculate the concentration of PM_{2.5} (CPM_{2.5} and CPM_{2.5f47}) recovered quantitatively from Container Nos. 3, 4, 5, 8 and 9.
- Use Equation 60 to determine the concentration of coarse PM from the quantitative recovery of PM_{<10>2.5} particulate matter (CPM_{<10>2.5}) from Container No. 2.
- Use Equations 61 and 80 to calculate the concentration of PM₁₀ (CPM₁₀ and CPM_{10f47}) recovered quantitatively from Container Nos. 2, 3, 4, 5, 8 and 9.

12.2 Reporting

You must include the following list of conventional elements in the emissions test report.

- Emission test description including any deviations from this protocol
- Summary data tables on a run-by-run basis
- Flowchart of the process or processes tested
- Sketch of the sampling location(s)
- Preliminary traverse data sheets including cyclonic flow checks
- Raw field data sheets
- Laboratory analytical sheets and case narratives
- Sample calculations
- Pre-test and post-test calibration data
- Chain of custody forms
- Documentation of process and air pollution control system data

12.3 Nomenclature

You must use the following nomenclature. Excluding the viscosity coefficients (C_#), mass fractions (m_#), standard deviations (S_#), the subscript "s" refers to stack gas; subscript "1" is for sample venturi; subscript "2" refers to the dilution air venturi or dilution air; and subscript "3" denotes mixed (exhaust) gas stream.

%CO₂=carbon dioxide concentration of gas stream, dry basis, percent by volume.

%O₂=oxygen concentration of gas stream, dry basis, percent by volume.

%O_{2,wet}=oxygen concentration of gas stream, percent by volume of wet gas.

[NOTE: the oxygen percentage used in Equation 3 is on a WET gas basis; that means that since O₂ is typically measured on a dry gas basis, the measured %O₂ must be multiplied by the quantity (1 - B_{WS}) to convert to a wet basis. Therefore %O_{2,wet} = (1 - B_{WS}) x %O_{2dry}]

A = area of stack or duct at sampling location, square inches.

A_n = area of sample nozzle, square feet.

A_{t1} = cross-sectional area of sample venturi throat, square feet.

A_{t2} = cross-sectional area of dilution air venturi throat, square feet.

B_f = average blockage factor calculated in Equation 17, dimensionless.

B_{W2} = moisture fraction of dilution air, mol/mol.

B_{W3} = moisture fraction of mixed gas (diluted stack gas sample), mol/mol.

B_{WS} = moisture fraction of stack gas, mol/mol.

C = Cunningham correction factor for particle diameter, D_p , and calculated using the actual stack gas temperature, dimensionless.

$C^*PM_{2.5}$ = In-stack concentration equivalent (actual O_2 , wet basis) of $PM_{2.5}$ applicable emission standard or test objective, gr/DSCF.

C_1 = -150.3162 (micropoise), gas viscosity equation coefficient

C_2 = 18.0614 (micropoise/ $K^{0.5}$), gas viscosity equation coefficient = 13.4622 (micropoise/ $^{\circ}R^{0.5}$)

C_3 = 1.19183×10^6 (micropoise K^2), gas viscosity equation coefficient = 3.86153×10^6 (micropoise $^{\circ}R^2$)

C_4 = 0.591123 (micropoise), gas viscosity equation coefficient

C_5 = 91.9723 (micropoise), gas viscosity equation coefficient

C_6 = 4.91705×10^{-5} (micropoise/ K^2), gas viscosity equation coefficient = 1.51761×10^{-5} (micropoise/ R^2)

C_a = acetone recovery rinse blank concentration, mg/g.

C_{d1} = discharge coefficient for sample venturi, as determined based on the C_d versus N_{Re} correlation according to Appendix B Equation B-9.

C_{d2} = discharge coefficient for dilution air venturi, as determined based on the C_d versus N_{Re} correlation according to Appendix B Equation B-9.

C_{f1} = flow coefficient for sample venturi. See Appendix B, Equation B-4.

C_{f2} = flow coefficient for dilution air venturi. See Appendix B, Equation B-4.

C_{f1} = flow coefficient for sample venturi, as determined according to Appendix B Equation B-4.

C_{f2} = flow coefficient for dilution air venturi, as determined according to Appendix B Equation B-4.

C_p' = coefficient for the pitot used in the preliminary traverse, dimensionless.

C_p = pitot tube coefficient for the combined cyclone-pitot assembly, dimensionless.

$C_{PM<10>2.5}$ = concentration of coarse particulate matter between 10 and 2.5 micrometers (acetone recovery rinse), gr/DSCF (gr/ft³).

C_{PM10} = concentration of PM_{10} , gr/DSCF (gr/ft³).

$C_{PM2.5}$ = concentration of $PM_{2.5}$, gr/DSCF (gr/ft³).

$C_{PM2.MDL}$ = method detection level for $PM_{2.5}$ concentration, gr/DSCF (gr/ft³).

$C_{PM2.MQL}$ = method quantifiable level for $PM_{2.5}$ concentration, gr/DSCF (gr/ft³).

C_r = re-estimated Cunningham correction factor for particle diameter equivalent to the actual cut size diameter and calculated using the actual stack gas temperature, dimensionless.

C_w = water recovery rinse blank concentration, mg/mg.

D_{50} = particle cut diameter, micrometers.

$D_{50(N+1)}$ = D_{50} value for cyclone IV calculated during the N+1 iterative step, micrometers.

D_{50-1} = re-calculated particle cut diameters based on re-estimated C_r , micrometers.

D_{50LL} = cut diameter for cyclone I corresponding to the 2.25 μm cut diameter for cyclone IV.

D_{50N} = D_{50} value for cyclone IV calculated during the Nth iterative step, micrometers.

D_{50T} = cyclone I cut diameter corresponding to the middle of the overlap zone shown in Figure 9 of Section 17, micrometers.

D_n = inner diameter of sampling nozzle mounted on cyclone I or IV, inches.

D_p = physical particle size, micrometers.

DR = dilution ratio (ratio of mixed gas volume to raw undiluted sample gas volume), dry basis, dimensionless.

F = contingency factor for minimum sample run duration.

g = gram.

g_c = gravitational constant (US customary units) = 32.174 lbf-ft/lbf-s².

gr = grain (weight).

I = isokinetic sampling ratio, percent.

iwc = inches of water column (pressure).

k_1 = sample venturi calibration constant for preliminary calculations (see Appendix B).

k_2 = dilution air venturi calibration constant for preliminary calculations (see Appendix B).

K_p = pitot tube calculation constant = 85.49, (ft/sec)/(pounds/mole ^{-°R}), for gas reference conditions of 527.67 °R and 29.92 inches Hg column, and mercury reference temperature of 0 °C.

m_1 = mass of residue determined for Container No. 1 (sample, field train proof blank corrected, >10 micrometers acetone rinse fraction), mg.

m_2 = mass of residue determined for Container No. 2 (sample, field train proof blank corrected, ≤10 and >2.5 micrometers acetone rinse fraction), if PM₁₀ determination is required, mg.

m_3 = mass of residue determined for Container No. 3 (sample, field train proof blank corrected, ≤2.5 micrometers water rinse fraction), mg.

m_{4A} = mass of residue determined for Container No. 4A (sample, field train proof blank corrected, ≤2.5 micrometers acetone rinse fraction), mg.

m_{4B} = mass of residue determined for Container No. 4B (sample, field train proof blank corrected, ≤2.5 micrometers acetone rinse fraction), mg.

$m_{1,MDL}$ = method detection level for the acetone recovery rinse net weights (>10 micrometers fraction), mg.

$m_{2,MDL}$ = method detection level for the acetone recovery rinse net weights (≤ 10 and > 2.5 micrometers fraction), mg.

$m_{3,MDL}$ = method detection level for the water recovery rinse net weights, mg.

$m_{4A,MDL}$ = method detection level for the Container 4A acetone recovery rinse net weights (≤ 2.5 micrometers fraction), mg.

$m_{4B,MDL}$ = method detection level for the Container 4B acetone recovery rinse net weights (≤ 2.5 micrometers fraction), mg.

m_a = mass of residue for acetone recovery rinse blank after evaporation, mg.

M_{ds} = molecular weight of dry stack and sample gas, pounds/pound mole.

m_{f2} = mass of particulate matter collected on the 47 mm dilution air blank filter, mg.

m_{f3} = mass of particulate matter collected on the 47 mm mixed gas (diluted sample) filter, mg.

$m_{f2,MQL}$ = method quantifiable level for the 47 mm dilution air blank filter, mg.

$m_{f3,MDL}$ = method detection level (mg) for the 47 mm sample filter

$m_{f3,MQL}$ = method quantifiable level (mg) for the 47 mm sample filter

$m_{PM_{2.5},MDL}$ = in-stack equivalent total $PM_{2.5}$ mass method detection level, mg.

$m_{PM_{2.5},MQL}$ = in-stack equivalent total $PM_{2.5}$ mass method quantifiable level, mg.

m_w = mass of residue of water recovery blank after evaporation, mg.

M_w = molecular weight of wet stack and sample gas, lbm/lbmol.

M_{w1} = molecular weight of wet sample gas, lbm/lbmol.

M_{w2} = molecular weight of wet dilution air, lbm/lbmol.

M_{d2} = molecular weight of dry air = 28.92 lbm/lbmol

n_1 = sample venturi calibration constant for preliminary calculations (see Appendix B).

n_2 = dilution air venturi calibration constant for preliminary calculations (see Appendix B).

N = number of iterative steps or total traverse points.

N_{reIV} = Reynolds Number for Cyclone IV, dimensionless.

P_1 = sample venturi gas absolute pressure, in. Hg.

P_2 = dilution air venturi gas absolute pressure, in. Hg.

P_3 = mixed gas absolute pressure at exhaust relative humidity sensor, in. Hg.

P_b = barometric pressure, in. Hg.

P_g = stack gas static gauge pressure, iwc.

P_s = absolute stack gas pressure, in. Hg.

P_{SR} = S-type Pitot tube reverse side gauge pressure, iwc.

P_{std} = standard reference absolute pressure = 760 mm Hg (29.92 in. Hg)

Q_1 = sample gas actual flow rate at sample venturi, ACFM wet.

$Q_{1(std)}$ = sample gas flow rate (standard temperature and pressure), dry, SCFM (ft^3/min).

$Q_{1(\text{std}),t}$ = target sample gas flow rate (standard temperature and pressure), dry, SCFM (ft³/min).

Q_2 = dilution air flow actual rate at dilution air venturi, ACFM wet.

$Q_{2(\text{std})}$ = dilution air flow rate (standard temperature and pressure), dry, SCFM (ft³/min).

$Q_{2(\text{std})T}$ = target dilution air flow rate based on assumed dilution ratio, dry (standard temperature and pressure), SCFM (ft³/min).

$Q_{3(\text{std})}$ = mixed gas (diluted sample) flow rate (standard temperature and pressure), dry, SCFM (ft³/min)

$Q_{3(\text{wet})}$ = mixed gas (diluted sample) flow rate (standard temperature and pressure, wet, SCFM (ft³/min).

Q_I = sample gas actual flow rate for cyclone I to achieve specified D_{50} , wet, ACFM (ft³/min).

Q_{IV} = sample gas actual flow rate for cyclone IV to achieve specified D_{50} , wet, ACFM (ft³/min).

Q_S = sample gas actual flow rate at cyclone I, wet, ACFM (ft³/min).

Q_{ST} = target sample gas actual flow rate at cyclone I required to achieve specified D_{50} , wet, ACFM (ft³/min).

$Q_{S(\text{std})}$ = sample gas actual flow rate (standard temperature and pressure), dry, SCFM (ft³/min).

$Q_{S(\text{std})T}$ = target sample gas actual flow rate (standard temperature and pressure), dry, SCFM (ft³/min).

$q_{2(\text{dry})}$ = dilution air flow rate through 47 mm filter for dilution air blank (standard temperature and pressure), dry, SCFM dry (ft³/min).

$q_{2(\text{wet})}$ = dilution air flow rate through 47 mm filter for dilution air blank (standard temperature and pressure), wet, SCFM (ft³/min).

$q_{3(\text{dry})}$ = mixed gas sample flow rate through 47 mm filter (standard temperature and pressure), dry, SCFM (ft³/min).

$q_{3(\text{wet})}$ = mixed gas sample flow rate through sample filter (standard temperature and pressure), wet, SCFM (ft³/min).

R = molar gas constant, 1545.35 ft-lbf/lbmol-°R.

r_1 = pressure ratio for sample venturi, as determined according to Appendix B Equation B-5.

r_2 = pressure ratio for dilution air venturi, as determined according to Appendix B Equation B-5.

RH_2 = relative humidity of dilution air, percent, at dilution air blower RH sensor.

RH_3 = relative humidity of diluted sample, percent, at exhaust gas blower RH sensor.

R_{max} = nozzle/stack velocity ratio parameter, maximum, dimensionless.

R_{min} = nozzle/stack velocity ratio parameter, minimum, dimensionless.

S = standard deviation, mg.

S_{m2} = precision (standard deviation) for acetone recovery rinses >2.5 μm and <10 μm, mg.

S_{m3} = precision (standard deviation) for water recovery rinses ≤2.5 μm, mg.

S_{m4} = precision (standard deviation) for acetone recovery rinses ≤2.5 μm, mg.

S_{f2} = precision (standard deviation) for 47 mm dilution air blank filter net weight, mg.

S_{f3} = precision (standard deviation) for 47 mm sample filter net weight, mg.

T_1 = sample gas absolute temperature at sample venturi, °R.

T_2 = dilution air absolute temperature at dilution air relative humidity sensor, °R.

T_3 = mixed gas absolute temperature at exhaust gas relative humidity sensor, °R.

T_s = stack gas absolute temperature, °R.

T_{std} = standard reference absolute temperature = 293.15 K (527.67 °R).

t_1 = dwell (sampling) time at point 1, minutes.

t_n = dwell (sampling) time at point n, minutes.

t_r = total projected run time, minutes.

t_{run} = total actual run time, minutes.

$V_{1(std)}$ = volume of stack gas sampled (standard temperature and pressure), dry, SCF (ft³).

$V_{2(std)}$ = total volume of dilution air during test run (standard temperature and pressure), dry, SCF (ft³).

$V_{2f(std)}$ = volume of dilution air sampled through 47 mm filter for dilution air blank (standard temperature and pressure), dry, SCF (ft³).

$V_{3(std)}$ = total volume of diluted stack gas sampled (standard temperature and pressure), dry, SCF (ft³).

$V_{3f(std)}$ = volume of diluted stack gas sampled through sample filter (standard temperature and pressure), dry, SCF (ft³).

v_{max} = maximum gas velocity calculated from Equations 26 or 27, ft/sec.

v_{min} = minimum gas velocity calculated from Equations 24 or 25, ft/sec.

v_n = sample gas velocity in the nozzle, ft/sec.

v_s = velocity of stack gas, ft/sec.

iwc = inches of water column.

γ_1 = specific heat ratio, stack gas (default value = 1.385), dimensionless.

γ_2 = specific heat ratio, dilution air (default value = 1.399), dimensionless.

Z = ratio of estimated cyclone IV D_{50} values, dimensionless.

Z_1 = compressibility factor for gas at sample venturi, dimensionless.

Z_2 = compressibility factor for gas at dilution air venturi, dimensionless.

β_1 = ratio of throat diameter to inlet diameter for sample venturi.

β_2 = ratio of throat diameter to inlet diameter for dilution air venturi.

ΔH_1 = sample venturi pressure drop, in. W.C.

ΔH_2 = dilution air venturi pressure drop, in. W.C.

$\Delta p'_1$ = stack gas velocity pressure measured at point 1 during the previous velocity traverse (preliminary traverse), in. W.C.

$((\Delta p')^{0.5}_{avg})^2$ = square of the average square root of $\Delta p'$ (from the previous velocity traverse), iwc.

Δp_1 = stack gas velocity pressure measured at point 1 during the run, iwc.

Δp_{cyc} = differential pressure between stack static gage pressure and sample venturi inlet static gage pressure, in. W.C.

Δp_m = observed stack gas velocity pressure using S-type Pitot tube in preliminary traverse, iwc.

Δp_{max} = maximum stack gas velocity pressure, iwc.

Δp_{min} = minimum stack gas velocity pressure, iwc.

Δp_3 = static gauge pressure at exhaust relative humidity sensor, iwc.

Δp_n = stack gas velocity pressure at point n during the test run, in. W.C.

Δp_s = stack gas velocity pressure calculated in Equation 16, in. W.C.

Δp_{s1} = stack gas velocity pressure adjusted for combined cyclone Pitot tube, in. W.C.

Δp_{s2} = stack gas velocity pressure corrected for blockage, in. W.C.

γ_1 = isentropic exponent of gas for sample venturi. For an ideal gas, this is the ratio of specific heats of the gas mixture, C_p/C_v .

γ_2 = isentropic exponent of gas for dilution air venturi. For an ideal gas, this is the ratio of specific heats of the gas mixture, C_p/C_v .

μ = gas viscosity at Cyclone I, micropoise.

μm = micrometers

2.08854337883712E-09 = units conversion constant, pounds force-second per square foot per micropoise (lbf-s/ft²/micropoise)

5.20231511 = units conversion constant, lbf/ft²/iwc

12.0 = constant calculated as 60 percent of 20.5 in² cross-sectional area of combined cyclone head, square inches.

13.6 = units conversion constant, iwc/in. Hg.

18 = molecular weight of water, lbm/lbmol.

28.31685 = units conversion constant, L/ft³.

144 = units conversion constant, in²/ft².

459.67 = units conversion constant, °F/°R.

70.72601527 = units conversion constant, lbf/ft²/in Hg.

7000 = units conversion constant, gr/lbm.

453592 = units conversion constant, mg/lbm.

12.4 What equations will I use in this method?

You will use the following equations to complete the calculations required in this test method. You will need to perform some calculations prior to the test (e.g., pre-test calculations), during the test, and after the test (e.g., post-test).

12.4.1 Pre-Test calculations.

The following calculations must be performed prior to the test to determine appropriate sampling and dilution supply rates for the test.

Molecular weight of dry stack gas.

$$M_{ds} = 0.44 \times (\%CO_2) + 0.32 \times (\%O_2) + 0.28 \times (100 - \%O_2 - \%CO_2) \quad \text{Equation 1}$$

[NOTE: Use estimated %CO₂ and %O₂ to calculate initial M_{ds} prior to the test run.]

Molecular weight of wet stack gas.

$$M_w = M_{ds} \times (1 - B_{ws}) + 18 \times (B_{ws}) \quad \text{Equation 2}$$

[NOTE: For these initial calculations, you must either assume a moisture concentration (based on prior knowledge of the process); estimate moisture following the procedures outlined in EPA Method 4 in 40 CFR 60, Appendix A; use a wet bulb-dry bulb measurement device; or use a hand-held hygrometer measurement device for stack gas temperatures less than 160 °F.)]

Gas Viscosity.

$$\mu = C_1 + C_2 \times \sqrt{T_s} + C_3 \times T_s^{-2} + C_4 \times (\%O_{2,wet}) - C_5 \times B_{ws} + C_6 \times B_{ws} \times T_s^2 \quad \text{Equation 3}$$

Stack gas pressure (absolute).

$$P_s = P_b + \frac{P_g}{13.6} \quad \text{Equation 4}$$

P_g may be estimated for sample train operation during tests from the S-type pitot tube reverse side gauge pressure, P_{sr}.

$$P_g = P_{sr} + (1 - C_p^2) \times \Delta p \quad \text{Equation 4A}$$

Cunningham correction factor. The Cunningham correction factor is calculated for D_p = 2.25 µm.

$$C = 1 + 0.0057193 \times \left[\frac{\mu}{P_s D_p} \right] \times \left[\frac{T_s}{M_w} \right]^{0.5} \quad \text{Equation 5}$$

Lower limit cut diameter for Cyclone I for N_{reIV} < 3162. The Cunningham correction factor is for a 2.25 µm diameter particle.

$$D_{50LL} = 9.507 \times C^{0.3007} \times \left[\frac{M_w \times P_s}{T_s} \right]^{0.1993} \quad (N_{reIV} < 3162) \quad \text{Equation 6}$$

Cut diameter for Cyclone I for the middle of the overlap zone.

$$D_{50T} = \left(\frac{11 + D_{50LL}}{2} \right) \quad \text{Equation 7}$$

Target sample gas flow rate using both Cyclone I and Cyclone IV (at stack conditions, wet basis).

$$Q_{sT} = Q_I = 0.07296 \times (\mu) \times \left[\frac{T_s}{M_w \times P_s} \right]^{0.2949} \times \left[\frac{1}{D_{50T}} \right]^{1.4102} \quad \text{Equation 8}$$

Target sample gas flow rate using only PM2.5 cyclone

For N_{re} less than 3,162.

$$Q_{IV} = 0.0060639 \times \left[\frac{\mu}{C^{0.4242}} \right] \times \left[\frac{P_s M_w}{T_s} \right]^{-0.5759} \times \left[\frac{1}{D_{50}} \right]^{0.8481} \quad \text{Equation 8A}$$

For N_{re} greater than 3162.

$$Q_{IV} = 0.007657 \times \left[\frac{\mu}{C^{0.6205}} \right] \times \left[\frac{P_s M_w}{T_s} \right]^{-0.3795} \times \left[\frac{1}{D_{50}} \right]^{1.241} \quad \text{Equation 8B}$$

Reynolds Number at Cyclone IV.

$$N_{reIV} = 8.64 \times 10^5 \times \left[\frac{P_s \times M_w}{T_s} \right] \times \left[\frac{Q_s}{\mu} \right] \quad \text{Equation 9}$$

Lower limit cut diameter for Cyclone I for $N_{relIV} \geq 3162$. The Cunningham correction factor is for a 2.25 μm diameter particle.

$$D_{50LL} = 10.0959 \times C^{0.44} \times \left[\frac{M_w \times P_s}{T_s} \right]^{0.06} \quad (N_{relIV} \geq 3162) \text{ Equation 10}$$

Target sample gas flow rate through Cyclones I and IV (at standard conditions, dry basis).

$$Q_{s(std)T} = Q_s \times \left(\frac{T_{std}}{P_{std}} \right) \times \left(\frac{P_s}{T_s} \right) \times (1 - B_{ws}) \quad \text{Equation 11}$$

Target dilution air flow rate at assumed dilution ratio, SCFM Dry.

$$Q_{2(std)T} = Q_{s(std)T} \times (DR - 1) \quad \text{Equation 12}$$

[NOTE: Refer to Section 8.3.3 of this method for selecting appropriate dilution ratio.]

Target sample venturi pressure differential setting.

$$\Delta H_1 = \left[\frac{Q_{s(std)T}}{(1 - B_{ws})} \times \frac{T_1}{T_{std}} \times \frac{P_{std}}{P_1} \times \frac{1}{k_1} \times \sqrt{\frac{P_1 \times M_{w1}}{T_1}} \right]^{n_1} \quad \text{Equation 13}$$

[NOTE: For Equation 13, M_{w1} is estimated to be equal to M_w which is calculated in Equation 2; T_1 is estimated to be 5 degrees higher than T_s ; and P_1 is estimated to be equal to P_b .]

Target dilution air venturi pressure differential setting.

$$\Delta H_2 = \left[\frac{Q_{2(std)T}}{(1 - B_{w2})} \times \frac{T_2}{T_{std}} \times \frac{P_{std}}{P_2} \times \frac{1}{k_2} \times \sqrt{\frac{P_2 \times M_{w2}}{T_s}} \right]^{n_1} \quad \text{Equation 14}$$

[NOTE: For this equation, M_{w2} is equal to $28.836 - 10.836 \times B_{w2}$. You may estimate B_{w2} from the measured relative humidity and temperature of the conditioned dilution air or assume $B_{w2} = 1$ percent for pre-test calculations); T_2 should be slightly higher than ambient temperature (approximately 5 °C or higher if the dilution air is heated); and P_2 is estimated to be equal to P_b .]

Stack gas velocity. Correct the mean preliminary velocity pressure for C_p and blockage using Equations 16, 17, and 18.

$$v_s = K_p \times C_p \times \left(\sqrt{(\Delta p')} \right)_{avg} \times \left[\sqrt{\frac{T_s}{P_s \times M_w}} \right] \quad \text{Equation 15}$$

Adjusted velocity pressure.

$$\Delta p_s = \Delta p_m \times \left[\frac{C_p}{C'_p} \right]^2 \quad \text{Equation 16}$$

Average probe blockage factor (both cyclones).

$$b_f = \frac{22}{A} \quad \text{Equation 17}$$

Adjusted velocity pressure.

$$\Delta p_{s2} = \Delta p_{s1} \times \left[\frac{1}{(1 - b_f)} \right]^2 \quad \text{Equation 18}$$

Calculated nozzle diameter for acceptable sample gas flow rate.

$$D_n = \left[\frac{3.056 \times Q_s}{v_s} \right]^{0.5} \quad \text{Equation 19}$$

Nozzle area.

$$A_n = \pi \times \frac{D_n^2}{4} \times \frac{1}{144} \quad \text{Equation 20}$$

Nozzle gas velocity.

$$v_n = \frac{\left(\frac{Q_s}{60}\right)}{A_n} \quad \text{Equation 21}$$

Minimum nozzle/stack velocity ratio parameter.

$$R_{min} = 0.2457 + \left(0.3072 - \frac{0.2603 \times (\mu) \times (Q_s)^{0.5}}{v_n^{1.5}}\right)^{0.5} \quad \text{Equation 22}$$

Maximum nozzle/stack velocity ratio parameter.

$$R_{max} = 0.4457 + \left(0.5690 + \frac{0.2603 \times (\mu) \times (Q_s)^{0.5}}{v_n^{1.5}}\right)^{0.5} \quad \text{Equation 23}$$

Minimum gas velocity for $R_{min} \leq 0.5$ or if R_{min} is an imaginary number.

$$v_{min} = v_n \times (0.5) \quad \text{Equation 24}$$

Minimum nozzle gas velocity for $R_{min} > 0.5$.

$$v_{min} = v_n \times R_{min} \quad \text{Equation 25}$$

Maximum nozzle gas velocity for $R_{max} \leq 1.5$.

$$v_{max} = v_n \times R_{max} \quad \text{Equation 26}$$

Maximum nozzle gas velocity for $R_{max} > 1.5$.

$$v_{max} = v_n \times (1.5) \quad \text{Equation 27}$$

Minimum velocity pressure.

$$\Delta p_{min} = 1.3686 \times 10^{-4} \times \left[\frac{P_s \times M_w}{T_s}\right] \times \left[\frac{v_{min}}{C_p}\right]^2 \quad \text{Equation 28}$$

Maximum velocity pressure.

$$\Delta p_{max} = 1.3686 \times 10^{-4} \times \left[\frac{P_s \times M_w}{T_s}\right] \times \left[\frac{v_{max}}{C_p}\right]^2 \quad \text{Equation 29}$$

Sampling time at point 1.

$$t_1 = \left(\frac{C_p}{C_p'}\right) \times \left(\frac{\Delta p_1'}{\Delta p_{avg}'}\right)^{0.5} \times \left(\frac{t_r}{N}\right) \quad \text{Equation 30}$$

12.4.2 Calculations during the test.

Sampling time at point n . You must use the actual test run data at each point, n , and test run point 1.

$$t_n = t_1 \times \frac{\sqrt{\Delta p_n}}{\sqrt{\Delta p_1}}; n = 2, 3, \dots, N \quad \text{Equation 31}$$

12.4.3 Calculations after the conclusion of the test

The following calculations must be performed after the test to determine if the appropriate PM₁₀ and PM_{2.5} cut sizes were sampled and the method criteria met.

Mixed gas (diluted sample) pressure at RH sensor pressure (absolute).

$$P_3 = P_b - \frac{\Delta p_3}{13.6} \quad \text{Equation 32}$$

Sample venturi gas pressure (absolute).

$$P_1 = P_s + \frac{\Delta P_{cyc}}{13.6} \quad \text{Equation 33}$$

Dilution air venturi gas pressure (absolute).

$$P_2 = P_1 + \frac{\left(\frac{-\Delta H_1 + \Delta H_2}{2.5} + 0.5\right)}{13.6} \quad \text{Equation 34}$$

[NOTE: the constant 2.5 is an empirical constant for the ratio of throat to total venturi pressure drop. The constant 0.5 is an empirical constant for the pressure drop across the mixing cone in inches of water.]

Dilution air moisture fraction.

$$B_{w2} = \frac{RH_2 \times 10^{\left(6.6912 - \frac{3144}{T_2 - 69.14}\right)}}{P_2} \quad \text{Equation 35}$$

Molecular weight of stack and sample gas, dry. Recalculate M_{ds} using dry gas composition data determined during the run. The equation is the same as Equation 1.

$$M_{ds} = 0.44 \times (\%CO_2) + 0.32 \times (\%O_2) + 0.28 \times (100 - \%O_2 - \%CO_2) \quad \text{Equation 36}$$

Molecular weight of stack and sample gas, wet. Recalculate M_{w1} using moisture data determined during the run.

$$M_{w1} = M_{ds} \times (1 - B_{ws}) + 18 \times (B_{ws}) \quad \text{Equation 37}$$

Molecular weight of dilution air, wet.

$$M_{w2} = 28.92 \times (1 - B_{w2}) + 18 \times (B_{w2}) \quad \text{Equation 38}$$

Sample flow rate at sample venturi conditions, ACFM wet.

$$Q_1 = \frac{C_{d1} \times C_{f1} \times A_{t1} \times P_1 \times T_{std} \times 60}{P_{std}} \times \sqrt{\frac{R}{Z_1 \times M_{w1} \times T_1}} \quad \text{Equation 39}$$

See Appendix B for venturi nomenclature and calculations.

Sample flow rate at cyclone (stack) conditions, ACFM wet. Q_s is recalculated using actual stack temperatures and pressures measured during the run.

$$Q_s = Q_1 \times \left(\frac{T_s}{T_1}\right) \times \left(\frac{P_1}{P_s}\right) \quad \text{Equation 40}$$

Dilution air flow rate at dilution air venturi conditions, ACFM wet.

$$Q_2 = \frac{C_{d2} \times C_{f2} \times A_{t2} \times P_2 \times T_{std} \times 60}{P_{std}} \times \sqrt{\frac{R}{Z_2 \times M_{w2} \times T_2}} \quad \text{Equation 41}$$

See Appendix B for venturi nomenclature and calculations.

Dilution air flow rate (at dry standard conditions), SCFM dry.

$$Q_{2(std)} = Q_2 \times \frac{528}{29.92} \times \left[\frac{P_2}{T_2}\right] \times (1 - B_{w2}) \quad \text{Equation 42}$$

Sample flow rate at standard conditions, SCFM dry. B_{ws} is the stack gas moisture decimal fraction as measured using another method.

$$Q_{1(std)} = Q_1 \times \frac{528}{29.92} \times \left[\frac{P_1}{T_1}\right] \times (1 - B_{ws}) \quad \text{Equation 43}$$

Dilution ratio.

$$DR = \frac{Q_{1(std)} + Q_{2(std)}}{Q_{1(std)}} \quad \text{Equation 44}$$

Actual particle cut diameter for Cyclone I. This is based on actual temperatures and pressures measured during the test run.

$$D_{50} = 0.15625 \times \left[\frac{T_s}{M_w \times P_s} \right]^{0.2091} \times \left[\frac{\mu}{Q_s} \right]^{0.7091} \quad \text{Equation 45}$$

Particle cut diameter for $N_{reIV} < 3162$ for Cyclone IV. C must be recalculated using the actual test run data and a D_{50} (D_p) of 2.5.

$$D_{50} = 0.0024302 \times \left[\frac{\mu}{Q_s} \right]^{1.1791} \times \left[\frac{1}{C} \right]^{0.5} \times \left[\frac{T_s}{P_s \times M_w} \right]^{0.6790} \quad (N_{reIV} < 3162) \text{ Equation 46}$$

[NOTE: The viscosity and Reynolds Number must be recalculated using the actual stack temperature, moisture, and oxygen (wet) concentrations.]

Particle cut diameter for $N_{reIV} > 3162$ for Cyclone IV. C must be recalculated using the actual test run data and a D_{50} (D_p) of 2.5.

$$D_{50} = 0.019723 \times \left[\frac{\mu}{Q_s} \right]^{0.8058} \times \left[\frac{1}{C} \right]^{0.5} \times \left[\frac{T_s}{P_s \times M_w} \right]^{0.3058} \quad (N_{reIV} \geq 3162) \text{ Equation 47}$$

Re-estimated Cunningham correction factor. You must use the actual test run Reynolds Number (N_{re}) value and select the appropriate D_{50} from Equation 46 or 47 (or Equation 49 or 50 if iterating).

$$C_r = 1 + 0.0057193 \times \left[\frac{\mu}{P_s D_{50}} \right] \times \left[\frac{T_s}{M_w} \right]^{0.5} \quad \text{Equation 48}$$

Re-calculated particle cut diameter for $N_{re} < 3162$.

$$D_{50-1} = 0.0024302 \times \left[\frac{\mu}{Q_s} \right]^{1.1791} \times \left[\frac{1}{C_r} \right]^{0.5} \times \left[\frac{T_s}{P_s \times M_w} \right]^{0.6790} \quad (N_{re} < 3162) \text{ Equation 49}$$

Re-calculated particle cut diameter for $N_{re} \geq 3162$.

$$D_{50-1} = 0.019723 \times \left[\frac{\mu}{Q_s} \right]^{0.8058} \times \left[\frac{1}{C_r} \right]^{0.5} \times \left[\frac{T_s}{P_s \times M_w} \right]^{0.3058} \quad (N_{re} \geq 3162) \text{ Equation 50}$$

Ratio (Z) of D_{50} and D_{50-1} Values.

$$Z = \frac{D_{50-1}}{D_{50}} \quad \text{Equation 51}$$

Acceptance criteria for Z values. The number of iterative steps is represented by N .

$$0.99 \leq \left[Z = \left(\frac{D_{50N}}{D_{50N+1}} \right) \right] \leq 1.01 \quad \text{Equation 52}$$

Volume sampled at standard conditions, dry SCF.

$$V_{1(std)} = Q_{1(std)} \times t_{run} \quad \text{Equation 53}$$

Isokinetic sampling ratio, percent.

$$I = \left(\frac{100 \times T_s \times V_{1(std)} \times P_{std}}{60 \times v_s \times t_{run} \times A_n \times P_s \times (1 - B_{ws}) \times T_{std}} \right) \quad \text{Equation 54}$$

Acetone recovery rinse blank concentration.

$$C_a = \frac{m_a}{W_a} \quad \text{Equation 55}$$

Water recovery rinse blank concentration.

$$C_w = \frac{m_w}{W_w} \quad \text{Equation 56}$$

(Equations 57, 58 and 59 are deleted)

Coarse PM (PM_{<10>2.5}) concentration, gr/DSCF.

$$C_{PM<10>2.5} = \left(\frac{7000}{453592} \right) \times \left(\frac{m_2}{V_{1(std)}} \right) \quad \text{Equation 60}$$

(Equation 61 is deleted)

Moisture content of mixed gas (diluted sample). Calculate the volumetric moisture fraction in the mixed gas (diluted sample), B_{w3} using the temperature, pressure and relative humidity of the mixed gas.

$$B_{w3} = \frac{\frac{RH_3}{100} \times 10^{(6.6912 - \frac{3144}{T_3 - 69.14})}}{P_3} \quad \text{Equation 62}$$

Moisture content of stack gas. Calculate the volumetric moisture fraction in the wet undiluted (raw) stack gas sample as follows:

$$B_{ws} = \frac{(B_{w3} \times Q_{3(wet)} - B_{w2} \times Q_2 \times \frac{T_{std}}{T_2} \times \frac{P_2}{P_{std}})}{Q_1 \times \frac{T_{std}}{T_1} \times \frac{P_1}{P_{std}}} \quad \text{Equation 63}$$

Where the volumetric flow rate of the wet diluted sample at EPA reference temperature and pressure, $Q_{3(wet)}$, is:

$$Q_{3(wet)} = \left(Q_1 \times \frac{T_{std}}{T_1} \times \frac{P_1}{P_{std}} + Q_2 \times \frac{T_{std}}{T_2} \times \frac{P_2}{P_{std}} \right) \quad \text{Equation 64}$$

Estimated dew point of mixed gas. You may estimate the dew point (saturation temperature) of the mixed gas, $T_{3(sat)}$ in °R, for determining the minimum dilution ratio and surface temperatures during test planning, based on the estimated stack gas moisture fraction and dilution air moisture fraction,

$$T_{3(sat)} = \frac{3144}{6.6912 - \log\left(\left(\frac{B_{ws}}{DR} + B_{w2} \times \left(1 - \frac{1}{DR}\right)\right) \times P_{bar}\right)} + 69.14 \quad \text{Equation 65}$$

Precision of field train proof blanks. Use the net weights without applying any blank corrections for each sample fraction from your most recent seven consecutive field train proof blanks collected during the same and/or prior tests. Calculate the precision expressed as standard deviation, in mg, for each sample fraction y using this equation.

$$S_y = \sqrt{\frac{\sum_{i=1}^{i=n} (x_{i,y} - \bar{x}_y)^2}{n-1}} \quad \text{Equation 66}$$

Where $x_{i,y}$ is the net weight of the i^{th} replicate of sample fraction y in mg, \bar{x}_y is the average of the seven sample fraction y net weights, and n is the number of replicates, which must be seven (7).

Method detection levels and method quantifiable levels. Calculate the precisions (standard deviations) in mg for the sample and dilution air blank filters, S_{f3} and S_{f2} , respectively, for the filters from the field train proof blanks. Use raw FTPB results without any corrections for calculating detection levels.

Calculate the method quantifiable levels in mg for the sample and dilution air blank filters, $m_{f3,MQL}$ and $m_{f2,MQL}$, respectively, according to Equation 67,

$$m_{fi,MQL} = \overline{m_{fi}} + S_{fi} \times 10 \quad \text{Equation 67}$$

Where $\overline{m_{f_i}}$ is the average net weight.

Calculate the method detection level in mg for the sample and dilution air blank filters, $m_{f_3,MDL}$ and $m_{f_2,MDL}$, respectively, according to Equation 67A,

$$m_{f_i,MDL} = \overline{m_{f_i}} + S_{f_i} \times t_{99,1t} \quad \text{Equation 67A}$$

Where $t_{99,1t}$ is the 99% confidence single-tailed Student's t-factor for (7-1)=6 degrees of freedom, equal to 3.14.

Calculate the precision (standard deviation) in mg for the field train proof blank $\leq 2.5 \mu\text{m}$ water recovery rinse, S_{m_3} . Calculate the method quantifiable level and method detection level in mg for the $\leq 2.5 \mu\text{m}$ water recovery rinse, in mg,

$$m_{3,MQL} = \overline{m_3} + S_{m_3} \times 10 \quad \text{Equation 68}$$

$$m_{3,MDL} = \overline{m_3} + S_{m_3} \times t_{99,1t} \quad \text{Equation 68A}$$

Calculate the method quantifiable level for the part A and part B $\leq 2.5 \mu\text{m}$ acetone recovery rinses, $m_{4A,MQL}$ and $m_{4B,MQL}$, and other sample fractions from the field train proof blanks similarly.

To determine the in-stack equivalent total PM_{2.5} mass method quantifiable level, $m_{PM2.5,MQL}$ in mg, when using the sample filter alone,

$$m_{PM2.5,MQL} = \left[(\overline{m_{f_3}} - \overline{m_{f_2}}) m_{f_{47RL}} + 10 \times \sqrt{(S_{f_3})^2 + (S_{f_2})^2} \right] \times DR \quad \text{Equation 69}$$

If the recovery rinse results are included, calculate the method quantifiable levels for the filter and rinses as follows,

$$m_{PM2.5,MQL} = \frac{(\overline{m_{f_3}} - \overline{m_{f_2}}) \times DR + \overline{m_3} + \overline{m_{4A}} + \overline{m_{4B}} + 10 \times \sqrt{(S_{f_3} \times DR)^2 + (S_{f_2} \times DR)^2 + (S_{m_3})^2 + (S_{m_{4A}})^2 + (S_{m_{4B}})^2}}{1} \quad \text{Equation 70}$$

The combined in-stack method detection level for PM_{2.5} mass, $m_{PM2.5,MDL}$, may be calculated similarly, substituting $t_{99,1t}$ for the value 10 in Equation 70.

To determine the in-stack equivalent of the PM_{2.5} concentration method quantifiable level, $CPM_{2.5,MQL}$ in gr/dscf,

$$C_{PM2.5,MQL} = \frac{7000}{453592} \times \frac{m_{PM2.5,MQL}}{V_{1(std)}} \quad \text{Equation 71}$$

Minimum test run duration. Calculate the minimum test run duration, t_r in minutes, based on the sample filter method quantifiable level and the in-stack concentration equivalent (at actual O₂, dry basis) of the applicable emission standard, $C_{PM2.5}^*$ in gr/DSCF,

$$t_r = \frac{1}{C_{PM2.5}^*} \times \frac{7000}{453592} \times \frac{m_{f_{47RL}}}{q_{ds(dry)}} \times DR \times F \quad \text{Equation 72}$$

where F is a contingency factor in minutes per minute (dimensionless) providing additional run time to allow for unforeseen factors.

PM₁₀ and PM_{2.5} concentration (sample filter). Calculate PM₁₀ and/or PM_{2.5} concentrations based on the sample filter results using the following equations.

Mixed dry gas volumetric flow rate at US EPA reference conditions, DSCF per minute.

$$Q_{3(std)} = Q_{1(std)} + Q_{2(std)} \quad \text{Equation 73}$$

The total mixed dry gas sample volume passed through the sample filter, DSCF.

$$V_{3f(std)} = (1 - B_{w3}) \sum_{n=1}^{n=N} q_{3(wet)_n} \times t_n \quad \text{Equation 74}$$

Where: t_n is dwell time in minutes at the n^{th} traverse point (or, the most frequent interval for which data are recorded); $q_{3(wet)_n}$ is the average wet mixed gas flow rate at standard temperature and pressure passed through the sample filter for the n^{th} traverse point in wet SCF per minute (1 SCF per minute = 28.31685 × liters per minute); and N is the total number of traverse points in a test.

The total dilution air dry gas volume passed through the 47 mm dilution air blank filter, DSCF.

$$V_{2f(std)} = (1 - B_{w2}) \sum_{n=1}^{n=N} q_{2(wet)_n} \times t_n \quad \text{Equation 75}$$

Where: $q_{2(wet)_n}$ is the average wet dilution air flow rate at US EPA reference temperature and pressure through the 47 mm dilution air blank filter for the n^{th} traverse point in DSCF per minute.

The total undiluted exhaust dry gas sample volume at US EPA reference conditions, DSCF.

$$V_{1(std)} = \sum_{n=1}^{n=N} Q_{1(std)_n} \times t_n \quad \text{Equation 76}$$

Total mixed dry gas volume at US EPA reference conditions, DSCF.

$$V_{3(std)} = \sum_{n=1}^{n=N} Q_{3(std)_n} \times t_n \quad \text{Equation 77}$$

Total dilution air dry gas volume at US EPA reference conditions, DSCF.

$$V_{2(std)} = \sum_{n=1}^{n=N} Q_{2(std)_n} \times t_n \quad \text{Equation 78}$$

PM_{2.5} concentration in the stack gas, gr/DSCF.

$$C_{PM2.5} = \left(\frac{7000}{453592} \right) \times \left(\frac{\left[\frac{m_{f3}}{V_{3f(std)}} \times V_{3(std)} - \frac{m_{f2}}{V_{2f(std)}} \times V_{2(std)} \right]}{V_{1(std)}} + \left(\frac{m_3 + m_{4A} + m_{4B}}{V_{1(std)}} \right) \right) \quad \text{Equation 79}$$

Where: m_{f3} is the mass of particulate matter collected on the sample filter in milligrams; and m_{f2} is the mass of particulate matter collected on the dilution air blank filter in milligrams.

NOTE: If m_{f2} is below the analytical detection limit, no dilution air blank correction should apply (substitute zero for m_{f2}).

PM₁₀ concentration in the stack gas, gr/DSCF.

$$C_{PM10f47} = \left(\frac{7000}{453592} \right) \times \left(\frac{\left[\frac{m_{f47,3}}{V_{f47,3(std)}} \times V_{3(std)} - \frac{m_{f47,2}}{V_{f47,2(std)}} \times V_{2(std)} \right]}{V_{1(std)}} + \left(\frac{m_2 + m_3 + m_{4A} + m_{4B}}{V_{1(std)}} \right) \right) \quad \text{Equation 80}$$

[NOTE: When the net weights of the sample fractions are below their respective method detection levels, the following practice is recommended. If m_{f2} is below the method detection level, substitute zero (i.e., no correction for dilution air blank). If $C_{PM2.5}$ is less than the method detection level, substitute the 47 mm filter method detection level for m_{f3} and annotate the result "below detection level" (BDL). If the acetone and water recovery rinse samples and field train proof blanks are not greater than their respective method detection levels, substitute zero for m_2 , m_3 , m_{4A} and/or m_{4B} .]

13. METHOD PERFORMANCE

13.1 Accuracy

Because the size and volatility of the particles making up source particulate matter emissions varies over a wide range and the mass concentration of particles varies with particle size, it is difficult to define the accuracy of PM_{2.5} measurements in an absolute sense. The accuracy of PM₁₀ and/or PM_{2.5} measurements is therefore defined in a relative sense, referenced to measurements provided by this reference method. Accordingly, accuracy of the overall measurement system is defined as the degree of agreement between two identical sampling trains operating simultaneously according to this test method with probe nozzles co-located in the stack and includes all sources of random (imprecision) and systematic (bias) measurement errors.

Accuracies (average relative percent difference) achieved in one test program based on nine replicate paired sampling train runs are:

- 47 mm PTFE membrane filters: 29 percent (3.3 micrograms);
- Acetone recovery rinses – cyclones: 2 to 59 percent (30 to 100 micrograms);
- Acetone recovery rinses - chamber: 13 to 121 percent (2,900 micrograms);
- Acetone recovery rinses – secondary chamber: 13 to 110 percent (400 to 3,700 micrograms);
- Water recovery rinses: [results unavailable].

Accuracy of the sample filter measurements also can be defined as the degree of agreement between two or more sample filters operating simultaneously during a test on the same sampling train. When defined in this manner, the accuracy achieved in one test program with three simultaneous sample filters was 2 percent to 11 percent (standard deviation of 3 to 11 micrograms).

13.2 Precision

Precision is defined in terms of replicate field train proof blank results obtained using this test method. Precision is defined as the standard deviation or relative standard deviation of at least seven replicate field train proof blanks that you will collect in the same or consecutive field test programs. This will establish the measurement precision that you can achieve within your organization's quality programs and practices. You will determine the precision for planning each test program based on your seven most recent field train proof blank results.

You will determine the precision for each sample fraction (sample filters, dilution air blank filters, acetone recovery rinses, water recovery rinses).

Precisions (standard deviations) achieved in tests using this method are:

- 47 mm PTFE membrane filters: 2.7 to 4.1 micrograms;
- Acetone recovery rinses – cyclones: 100 to 400 micrograms;
- Acetone recovery rinses – chamber: 600 to 1,100 micrograms;
- Acetone recovery rinses – secondary chamber: 700 to 1,700 micrograms;
- Water recovery rinses: [results unavailable].

13.3 Method detection level

The method detection level for each sample fraction (sample filters, acetone recovery rinses, water recovery rinses) is defined in Section 12.4.4 of this method. The method detection level corresponds to the lowest level that can be distinguished from zero with 99 percent confidence.

14. POLLUTION PREVENTION

[Reserved]

15. WASTE MANAGEMENT

[Reserved]

16. REFERENCES

We cited or used the following references in the development of this test method:

1. Dawes, S.S., and W.E. Farthing. "Application Guide for Measurement of PM_{2.5} at Stationary Sources," U.S. Environmental Protection Agency, Atmospheric Research and Exposure Assessment Laboratory, Research Triangle Park, NC, 27511, EPA-600/3-90/057 (NTIS No.: PB 90-247198), November 1990.
2. Hawks, Bruce, "Water Saturation Vapor Pressure Calculation," Stack Sampling Newsletter; July, 1979.
3. Hildemann, L. M., Cass, G. R. & Markowski, G. R. 1989. A Dilution Stack Sampler for Collection of Organic Aerosol Emissions: Design, Characterization and Field Tests, *Aerosol Science and Technology*, **10**: 1, 193-204.
4. Mobley, D.J., "Additional Guidance on PM_{2.5} Cassette Handling and Transportation," U.S. Environmental Protection Agency; Emissions, Monitoring & Analysis Division; January 19, 2000.
5. [deleted].
6. *Stationary source emissions — Test method for determining PM_{2.5} and PM₁₀ mass in stack gases using cyclone samplers and sample dilution*, ISO 25597:2013(E). International Organization for Standardization, Geneva, Switzerland.
7. U.S. Environmental Protection Agency, Federal Reference Methods 1 through 5 and Method 17, Appendix A, in *Part 60, Chapter 40, U.S. Code of Federal Regulations*.
8. U.S. Environmental Protection Agency, Federal Reference Method 201A, Appendix M, in *Part 51, Chapter 40, U.S. Code of Federal Regulations*.
9. U.S. Environmental Protection Agency, Conditional Test Method (CTM) 039, <https://www3.epa.gov/ttn/emc/ctm/ctm-039.pdf> accessed August 24, 2016.
10. U.S. Environmental Protection Agency, Reference Method for the Determination of Fine Particulate Matter as PM_{2.5} in the Atmosphere, Appendix L, in *Part 50, Chapter 40, U.S. Code of Federal Regulations*.
11. *Quality Assurance Guidance Document 2.12. Monitoring PM_{2.5} in Ambient Air Using Designated Reference or Class I Equivalent Methods*. National Exposure Research Laboratory, U.S. Environmental Protection Agency, Research Triangle Park, North Carolina. January 2016 or later edition.
12. Stationary Source Specific Methods, Volume III, in *Quality Assurance Handbook for Air Pollution Measurement Systems*, EPA-600/4-77 -027b, Environmental Monitoring and Support Laboratory, Office of Research and Development, U.S. Environmental Protection Agency, Research Triangle Park, North Carolina. August 1977.
13. Martin, R.M. Construction Details of Isokinetic Source-Sampling Equipment, APTD-0581. U.S. Environmental Protection Agency, Research Triangle Park, NC. April 1971.

14. Rom, J.J. Maintenance and Calibration of Isokinetic Sampling Equipment, APTD-0576, U.S. Environmental Protection Agency, Research Triangle Park, North Carolina. March 1972.
15. McDougall, D. et al., ACS Committee on Environmental Improvement. 1980. Guidelines for Data Acquisition and Data Quality Evaluation in Environmental Chemistry. *Anal. Chem.* 52, 2242-2249.
16. England, G.C. Development of Fine Particulate Emission Factors and Speciation Profiles for Oil and Gas-fired Combustion Systems, Final Report, GE Energy and Environmental Research Corporation, Irvine, California, prepared for U.S. Department of Energy, Gas Research Institute, American Petroleum Institute, California Energy Commission and New York State Energy Research and Development Authority, 2004.

17. TABLES, FIGURES, FLOWCHARTS, AND VALIDATION DATA

You must use the following tables, diagrams, flowcharts, and data to complete this test method successfully.

Table 1: Typical Particulate Matter Concentrations

Particle Size Range	Concentration and percent by Weight (CTM 39)	Low Concentration and percent by Weight
Total collectable particulate	0.015 gr/DSCF (34 mg/dscm)	0.0001 gr/DSCF (0.3 mg/dscm)
≤ 10 and > 2.5 μm	40 percent of total collected particulate matter	0 (not greater than method quantifiable level or not significantly different from field train proof blanks)
≤ 2.5 μm	20 percent of total collected particulate matter	100 percent of total collected particulate matter

Table 2: Required Cyclone Cut Diameters (D_{50})

Cyclone	Min. Cut Diameter, μm	Max. Cut Diameter, μm
PM ₁₀ Cyclone (Cyclone I from five stage cyclone)	9	11
PM _{2.5} Cyclone (Cyclone IV from five stage cyclone)	2.25	2.75

Table 3: ΔH_1 Values Based on Preliminary Traverse Data

Stack Temperature, ($^{\circ}\text{R}$)	Ts - 50 $^{\circ}$	Ts	Ts + 50 $^{\circ}$
ΔH_1 (inches W.C.)	-	-	-

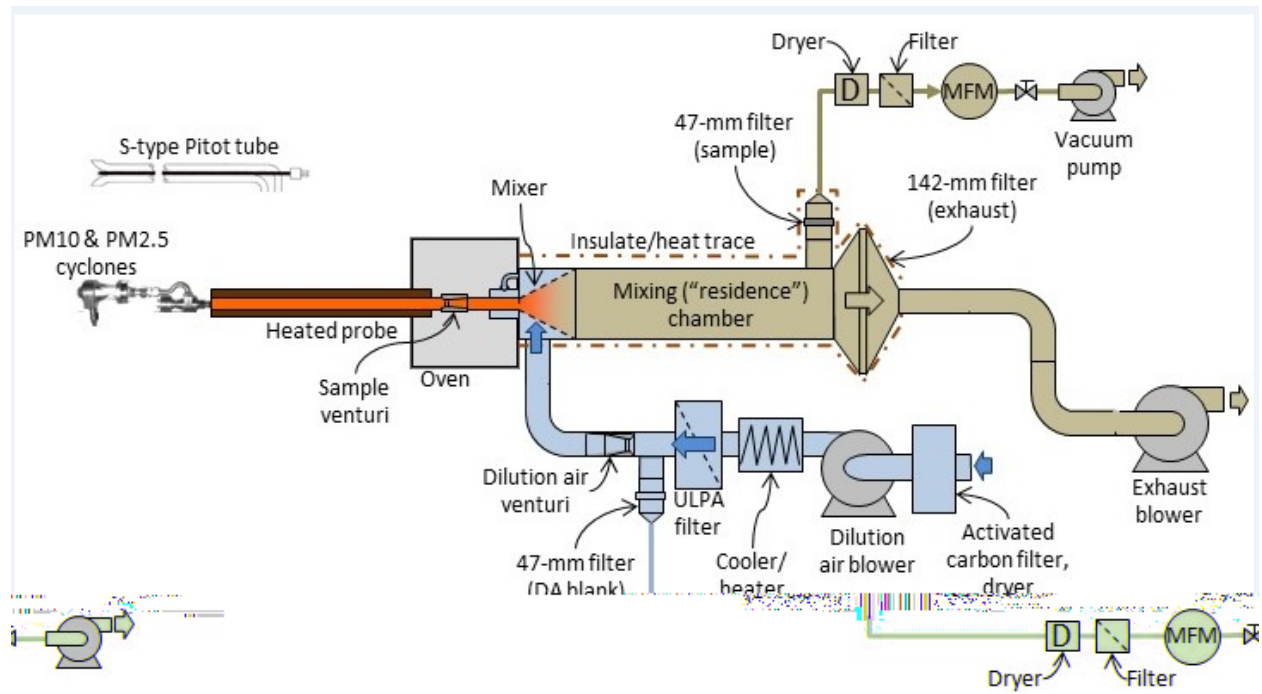

Figure 1: OTM37 dilution sampling train for low PM_{10} and/or $PM_{2.5}$ concentrations.

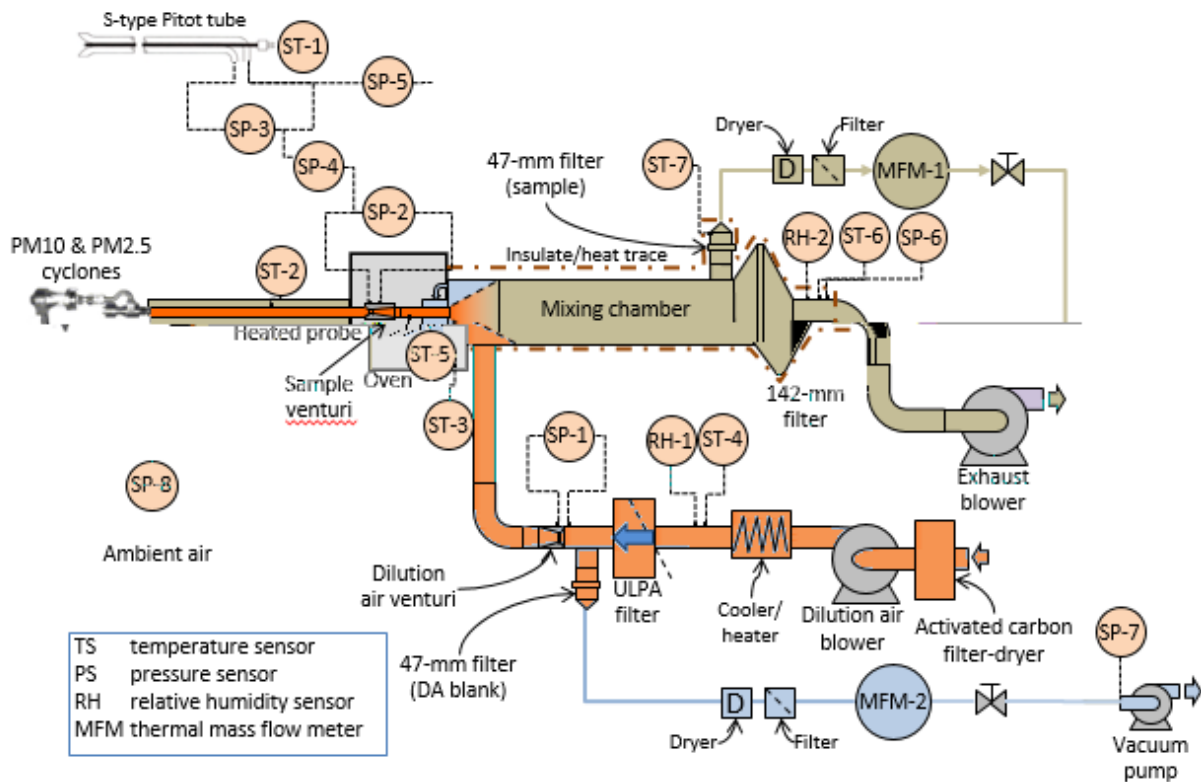
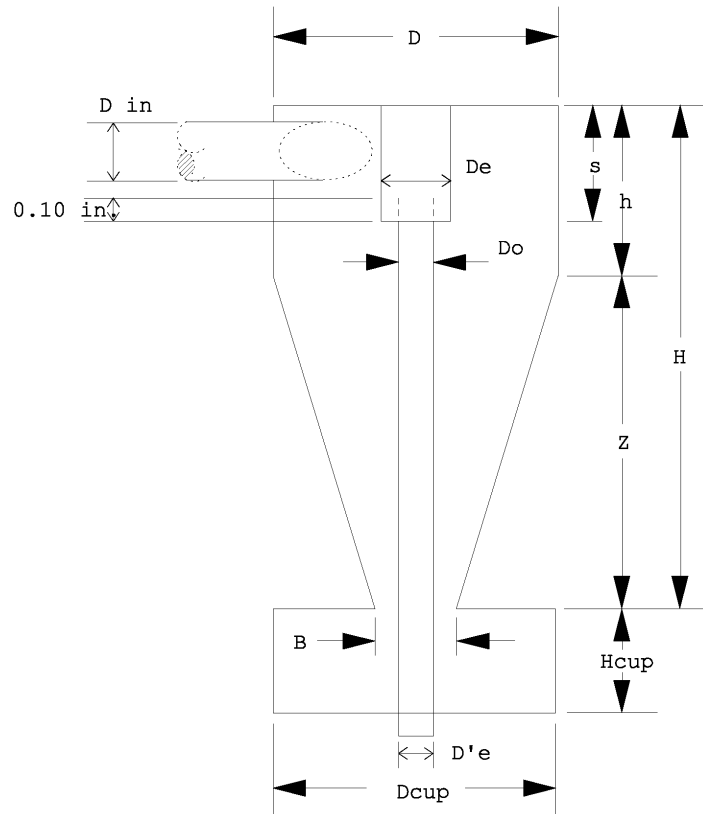

Figure 2: Dilution sampler pressure, temperature and relative humidity instrumentation.

Table 4: Pressure, Temperature, and Relative Humidity Sensor IDs

Instru-ment ID	Description	Suggested Range	Corresponding Nomenclature
ST-1	Stack gas temperature sensor	0 to 300 °C (0 to 600 °F)	T_s
ST-2	Stack probe temperature sensor	0 to 300 °C (0 to 600 °F)	--
ST-3	Oven temperature sensor	0 to 300 °C (0 to 600 °F)	--
ST-4	Dilution air temperature sensor	0 to 50 °C (0 to 120 °F)	T_2
ST-5	Sample venturi temperature sensor	0 to 300 °C (0 to 600 °F)	T_1
ST-6	Exhaust gas temperature sensor	0 to 50 °C (0 to 120 °F)	T_3
ST-7	47-mm filter outlet mixed gas temperature sensor	0 to 50 °C (0-120 °F)	--
SP-1	Dilution air venturi differential pressure transducer	0-250 mm wc (0 to 10 iwc)	ΔH_2
SP-2	Sample venturi differential pressure transducer	0-130 mm wc (0 to 5 iwc)	ΔH_1
SP-3	Pitot tube differential pressure (velocity head)	0 to 130 mm wc (0 to 5 iwc)	Δp_m
SP-4	Cyclone differential pressure transducer	-250 to +250mm wc (-10 to	Δp_{cyc}
SP-5	Stack gas static gauge pressure (pitot) transducer	-630 to +630 mm wc (-25 to	P_g
SP-6	Exhaust vacuum pressure transducer	0 to 760 mm Hg (0 to 50 iwc)	P_3
SP-7	Sample pump vacuum gauge	0 to -30 in. Hg	--
SP-8	Barometric pressure sensor	17.4-32.5 in. Hg	P_b
RH-1	Dilution air relative humidity	0 to 100%	RH ₁
RH-2	Mixed gas relative humidity	0 to 100%	RH ₂
MFM-1	Mixed gas sample flow rate (47-mm filter)	0 to 100 Lpm (0 to 3.5 cfm)	$q_{3(dry)}$ OR $q_{3(wet)}$
MFM-2	Dilution air blank flow rate (47-mm filter)	0 to 100 Lpm (0 to 3.5 cfm)	$q_{2(dry)}$ OR $q_{2(wet)}$



Cyclone I (10 Micrometer)	Cyclone Interior Dimensions (cm ± 0.02 cm)											
	Din	D	De	B	H	h	Z	S	Hcup	Dcup	De'	Do
	1.27	4.47	1.50	1.88	6.95	2.24	4.71	1.57	2.25	4.45	1.02	1.24

Figure 3: Design specifications for cyclone I (10 micrometers).

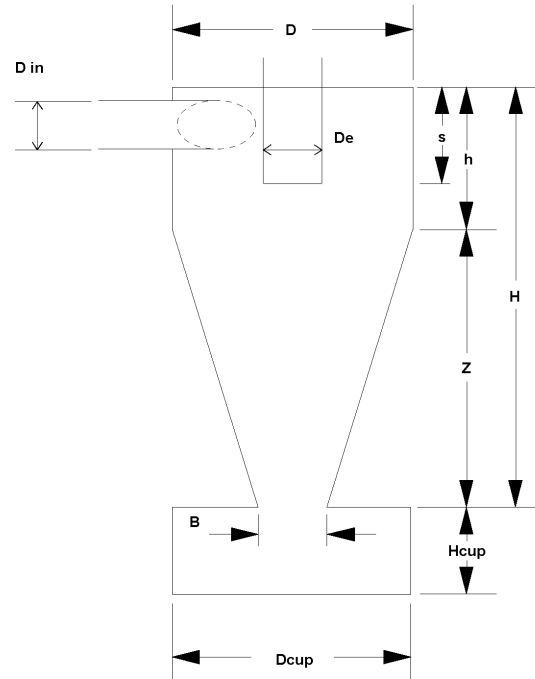

Cyclone IV (2.5 Micrometer)	Cyclone Interior Dimensions (cm \pm 0.02 cm)									
	D_{in}	D	D_e	B	H	h	Z	S	H_{cup}	D_{cup}
	0.51	2.54	0.59	1.09	2.68	1.03	1.65	0.58	2.22	2.62

Figure 4: Design specifications for cyclone IV (2.5 micrometers).

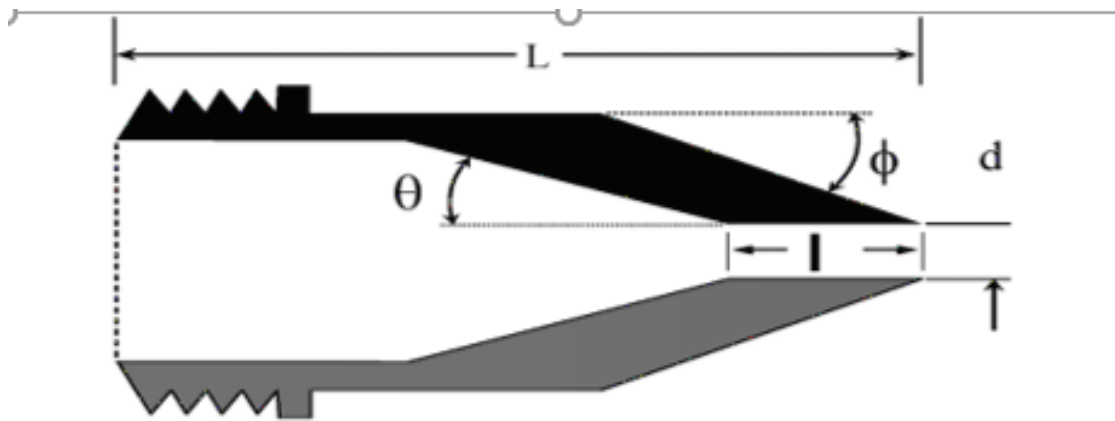

Figure 5: Design specifications for cyclone I (10 micrometers) sample nozzles.

Table 5: Design Specifications for cyclone I

d- Nozzle Diameter, (inches)	θ -Cone Angle (degrees)	Φ – outside taper (degrees)	l - Straight inlet (inches)	L – Total Length (inches)
0.125	4	15	<0.05	2.710 \pm 0.05
0.136	4	15	<0.05	2.653 \pm 0.05
0.150	4	15	<0.05	2.553 \pm 0.05
0.164	5	15	<0.05	1.970 \pm 0.05
0.180	6	15	<0.05	1.572 \pm 0.05
0.197	6	15	<0.05	1.491 \pm 0.05
0.215	6	15	<0.05	1.450 \pm 0.05
0.233	6	15	<0.05	1.450 \pm 0.05
0.264	5	15	<0.05	1.450 \pm 0.05
0.300	4	15	<0.05	1.480 \pm 0.05
0.342	4	15	<0.05	1.450 \pm 0.05
0.390	3	15	<0.05	1.450 \pm 0.05

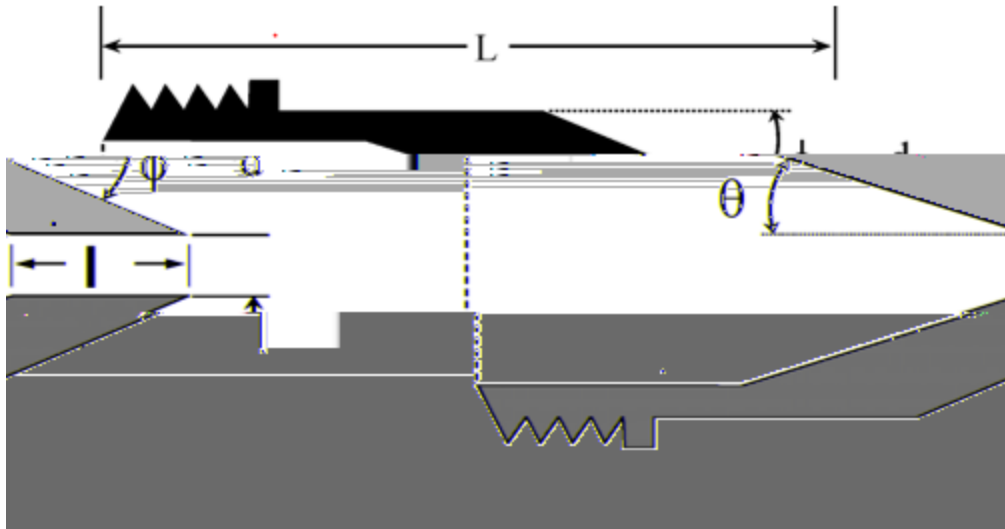

Figure 6: Design specifications for cyclone IV (2.5 micrometers) sample nozzles. Dimensions

Table 6 Design Specifications for Cyclone IV

d- Nozzle Diameter, (inches)	θ -Cone Angle (degrees)	ϕ – outside taper (degrees)	l - Straight inlet (inches)	L – Total Length (inches)
0.125	3	15	<0.05	1.450 \pm 0.05
0.138	2	15	<0.05	1.450 \pm 0.05
0.156	1	15	<0.05	1.450 \pm 0.05
0.172	1	15	<0.05	1.450 \pm 0.05
0.188	1	15	<0.05	1.450 \pm 0.05
0.200	0	15	<0.05	1.450 \pm 0.05

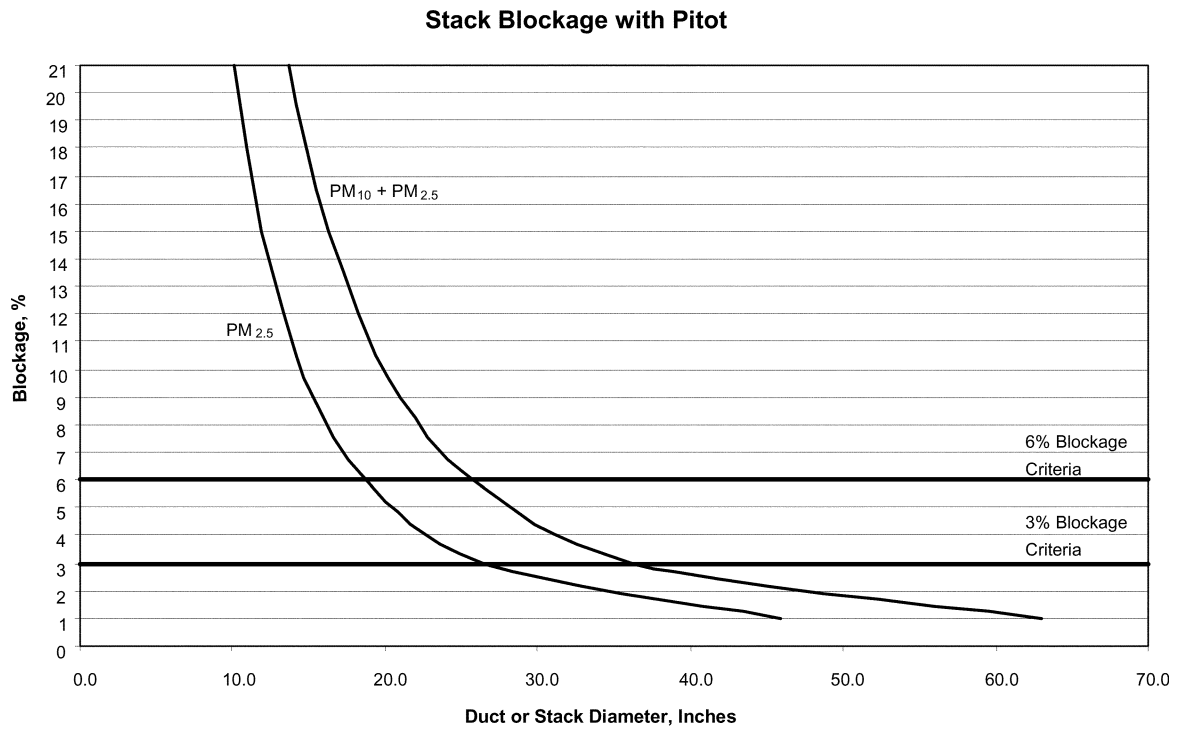

Figure 7: Gas flow blockage by the combined cyclone sampling head.

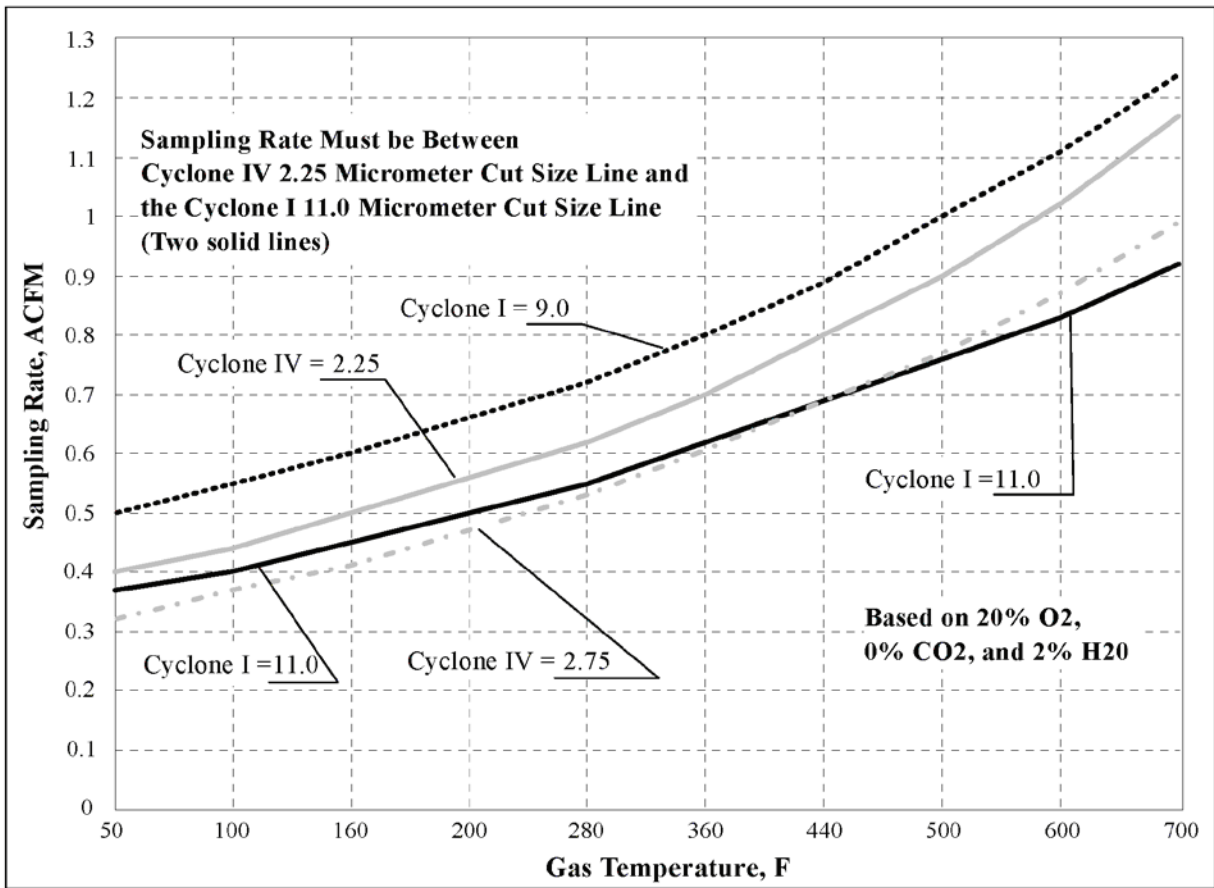

Figure 8: Acceptable sample gas flow rate for combined cyclone heads.

ff

Figure 9: 47 mm filter holder assembly.

[NOTE: The filter holder top (inlet) design shown above is compatible with ambient air PM_{2.5} samplers used under 40 CFR 50 Appendix L and is designed to uniformly distribute particulate matter on the filter surface. The material may be stainless steel or other inert anti-static material rather than aluminum.]

Figure 10: Filter holder, top.

q **Figure 11: Filter cassette, upper section.**

Figure 12: Filter support screen.

Figure 13: Filter cassette, lower section.

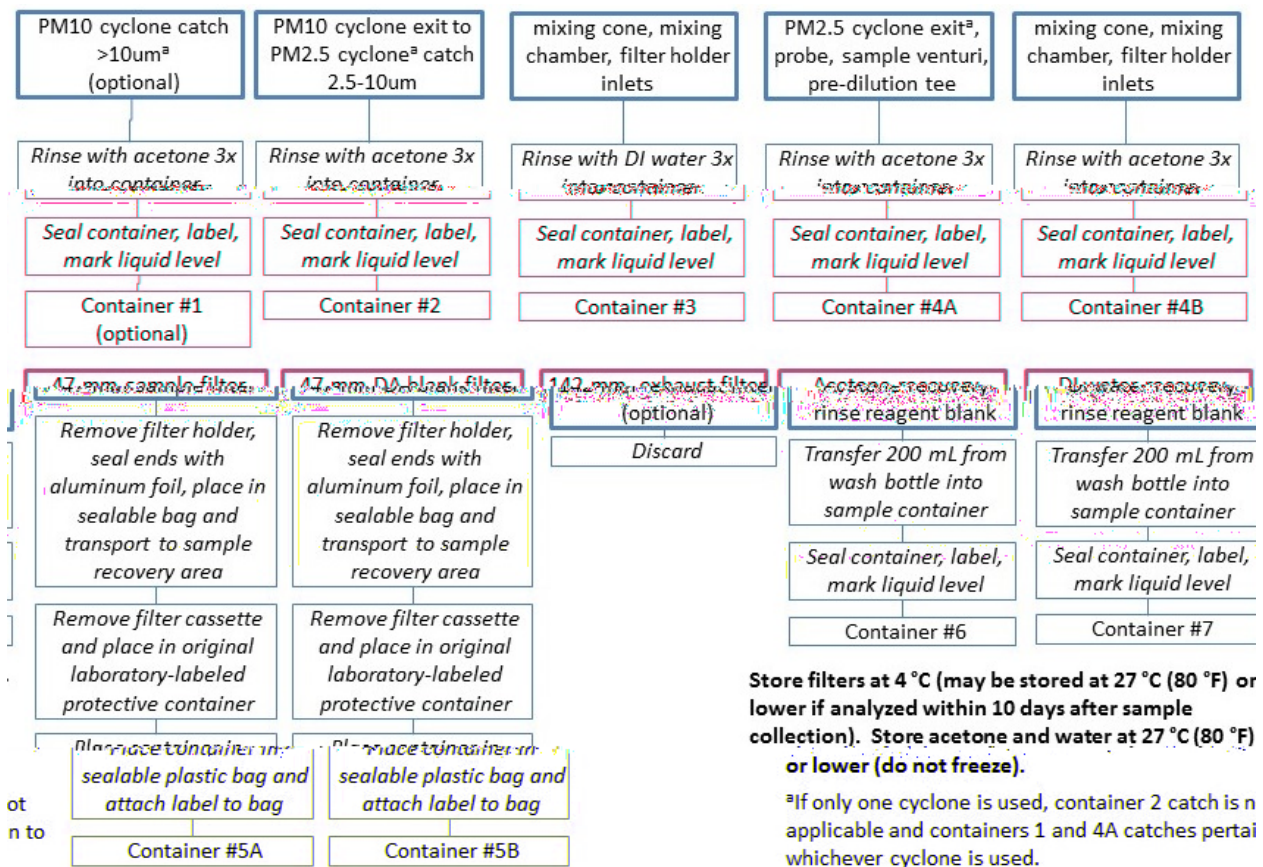

Figure 14: Sample recovery scheme.

APPENDIX A: [RESERVED]

APPENDIX B: VENTURI CALIBRATION AND CALCULATIONS

The procedures given in this Appendix are similar to calibration and calculations for subsonic venturi flow meters given in 40 CFR Part 1065.

1 Calibration Procedure

Calibrate each venturi flow meter to determine its calibration coefficient, C_d , for the expected range of flow rates and N_{Re} . Calibrate the venturi flow meter using ambient air for the calibration medium as follows:

1. Connect the venturi flow meter, reference flow meter and calibration equipment as shown in Figure B-1 of this Appendix. The reference flow meter may be any device calibrated to a recognized standard that measures volume of air flow, such as a venturi flow meter, orifice flow meter, dry gas meter, or similar devices.
2. Verify that any leaks between the reference flow meter and the venturi flow meter are less than 0.3 percent of the total flow at the highest restriction.
3. Start the blower downstream of the venturi flow meter.
4. While the venturi flow meter operates, maintain a constant temperature at the venturi flow meter inlet within ± 2 percent of the mean absolute temperature, \bar{T} .
5. Set the variable restrictor or variable-speed blower to a flow rate greater than the greatest flow rate expected during testing. You may not extrapolate flow rates beyond calibrated values, so we recommend that you make sure the Reynolds number, N_{Re} , at the venturi flow meter throat at the greatest calibrated flow rate is greater than the maximum N_{Re} expected during testing.
6. Operate the venturi flow meter for at least 3 minutes to stabilize the system. Continue operating the venturi flow meter and record the mean of at least 30 seconds of sampled data of each of the following quantities:
 - a. The mean flow rate of the reference flow meter \bar{n}_{ref} . This may include recording several measurements of different quantities for calculating \bar{n}_{ref} , such as reference meter volumes, pressures and temperatures.
 - b. Optionally, the mean dew point of the calibration air, T_{dew} . See Section 2 below for permissible assumptions.
 - c. The mean absolute temperature at the venturi inlet, \bar{T} .
 - d. The mean static absolute pressure at the venturi inlet, \bar{P} . This may include recording several measurements of different quantities for calculating \bar{P} , such as barometric pressure and gage static pressure.
 - e. The mean static differential pressure between the static pressure at the venturi inlet and the static pressure at the venturi throat, $\Delta\bar{H}$ venturi flow meter.
7. Incrementally close the restrictor valve or decrease the blower speed to decrease the flow rate.
8. Repeat the steps in (6) and (7) above to record data at a minimum of ten flow rates.
9. Determine an equation to quantify C_d as a function of N_{Re} by using the collected data and the equations in Section 2 below. Section 2 also includes statistical criteria for validating the C_d versus N_{Re} equation.

10. Use the venturi flow meter only between the minimum and maximum calibrated N_{Re} . If you want to use the venturi flow meter at a lower or higher N_{Re} , you must recalibrate the venturi flow meter.

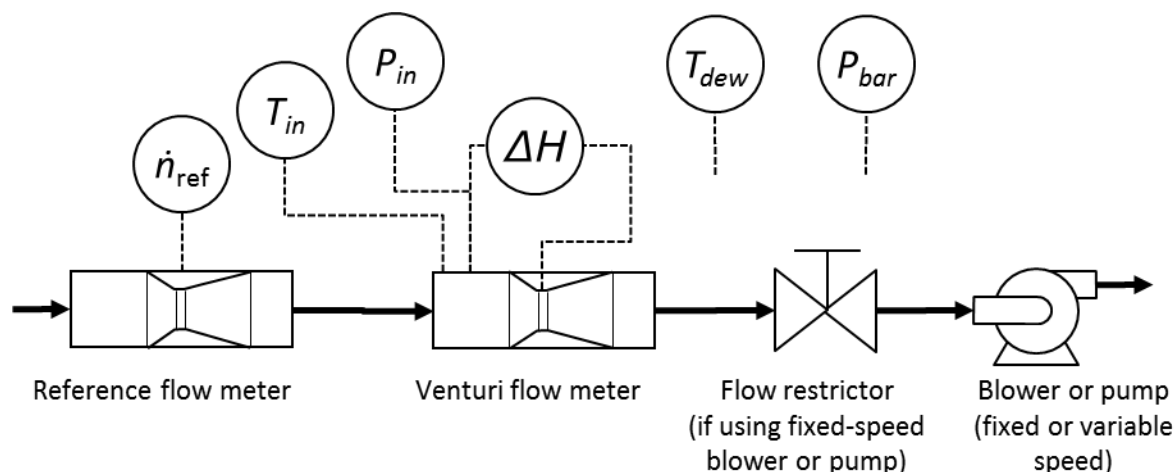

Figure B-1: Venturi flow meter calibration setup.

2 Calibration Calculations

[NOTE: When working in U.S. Customary units, be sure to note that 1 lbmol = 453.592 mol, $R = 1545.35 \text{ ft-lbf/lbmol} \cdot ^\circ\text{R}$ and that the gravitational constant, $g_c = 32.174 \text{ lbf-ft/lbf-s}^2$, must be applied when calculating molar flow rate and Reynolds number.]

2.1 Reference meter conversions

The calibration equations in this section use molar flow rate, \dot{n}_{ref} , as a reference quantity. If your reference meter outputs a flow rate in a different quantity, such as standard volume rate, $Q_{ref, std}$, actual volume rate, $Q_{ref, act}$, or mass rate, \dot{m}_{ref} , convert your reference meter output to a molar flow rate using the following equations, noting that while values for volume rate, mass rate, pressure, temperature, and molar mass may change during an emission test, you should ensure that they are as constant as practical for each individual set point during a flow meter calibration:

$$\dot{n}_{ref} = \frac{Q_{ref, std} \times P_{std}}{T_{std} \times R} = \frac{Q_{ref, act} \times P_{ref, act}}{T_{ref, act} \times R} = \frac{\dot{m}_{ref}}{M_{air}} \quad \text{Equation B-1}$$

Where:

\dot{n}_{ref} = reference molar flow rate;

$Q_{ref, std}$ = reference volume flow rate, corrected to standard pressure and a standard temperature;

$Q_{ref, act}$ = reference volume flow rate at the actual pressure and temperature of the flow rate;

\dot{m}_{ref} = reference mass flow;

P_{std} = standard absolute pressure;

P_{act} = actual pressure of the flow rate;

T_{std} = standard absolute temperature;

T_{act} = actual temperature of the flow rate;

R = molar gas constant;

M_{air} = molar mass of the air used for calibration (wet basis).

Example 1:

$$Q_{ref, std} = 0.583 \text{ ft}^3/\text{min} = 0.000275 \text{ m}^3/\text{sec}$$

$$P_{std} = 29.9213 \text{ in Hg @32 }^\circ\text{F} = 101.325 \text{ kPa} = 101325 \text{ Pa} = 101325 \text{ kg}/(\text{m}\cdot\text{sec}^2)$$

$$T_{std} = 68.0 \text{ }^\circ\text{F} = 293.15 \text{ K}$$

$$R = 8.314472 \text{ J}/(\text{mol}\cdot\text{K}) = 8.314472 \text{ (m}^2\cdot\text{kg)} / (\text{sec}^2\cdot\text{mol}\cdot\text{K})$$

$$\dot{n}_{ref} = \frac{0.000275 \times 101325}{293.15 \times 8.314472} = 0.01144 \text{ mol}/\text{sec}$$

Example 2:

$$\dot{m}_{ref} = 0.01985 \text{ kg}/\text{min} = 0.3308 \text{ g}/\text{sec}$$

$$\dot{M}_{air} = 28.92 \text{ g}/\text{mol}$$

$$\dot{n}_{ref} = \frac{0.3308}{28.92} = 0.01144 \text{ mol}/\text{sec}$$

2.2 Venturi governing equations and permissible assumptions.

These governing equations assume subsonic one-dimensional isentropic inviscid flow of an ideal gas. Paragraph 2.2(5) of this Appendix describes other assumptions that may apply. If good engineering judgment dictates that you should account for gas compressibility, you may either use an appropriate equation of state to determine values of Z as a function of measured pressure and temperature, or you may develop your own calibration equations based on good engineering judgment. Note that the equation for the flow coefficient, C_f , is based on the ideal gas assumption that the isentropic exponent, γ , is equal to the ratio of specific heats, C_p/C_v . If good engineering judgment dictates using a real gas isentropic exponent, you may either use an appropriate equation of state to determine values of γ as a function of measured pressures and temperatures, or you may develop your own calibration equations based on good engineering judgment.

1. Calculate molar flow rate, \dot{n} , as follows:

$$\dot{n}_i = C_{di} \times C_{fi} \times \frac{A_{ti} \times P_i}{\sqrt{Z_i \times M_i \times R \times T_i}} \quad \text{Equation B-2}$$

Where:

$i = 1$ for sample venturi;

$i = 2$ for dilution air venturi;

\dot{n}_{ref} = molar flow rate through venturi i ;

C_{di} = discharge coefficient for venturi i , as determined in paragraph 2.2(2) of this Appendix;

C_{fi} = flow coefficient for venturi i , as determined in paragraph 2.2(3) of this Appendix;

A_{ti} = throat cross-sectional area for venturi i ;

P_i = absolute static pressure at the inlet of venturi i

Z_i = compressibility factor of gas at venturi i ;

M_i = molecular weight of gas at venturi i ;

R = molar gas constant;

T_i = absolute temperature at the inlet of venturi i .

2. Using the data collected in Section 1 above, calculate C_d for each flow rate using the following equation:

$$C_{di} = \dot{n}_{ref} \times \frac{\sqrt{Z_i \times M_i \times R \times T_i}}{C_{fi} \times A_{ti} \times P_i} \quad \text{Equation B-3}$$

Where:

\dot{n}_{ref} = a reference molar flow rate.

3. Determine C_{fi} :

Use the following equation to calculate C_{fi} for each flow rate for venturi i :

$$C_{fi} = \left[\frac{2 \times \gamma_i \times \left(r_i^{\frac{\gamma_i-1}{\gamma_i}} - 1 \right)}{(\gamma_i-1) \times \left(\beta_i^4 - r_i^{\frac{-2}{\gamma_i}} \right)} \right]^{\frac{1}{2}} \quad \text{Equation B-4}$$

Where:

γ_i = isentropic exponent of gas for venturi i . For an ideal gas, this is the ratio of specific heats of the gas mixture, C_p/C_v .

r_i = pressure ratio for venturi i , as determined in paragraph 2.2(4) of this Appendix.

β_i = ratio of throat diameter to inlet diameter for venturi i .

4. calculate r_i for venturi i using the following equation:

$$r_i = 1 - \frac{\Delta H_i}{P_i} \quad \text{Equation B-5}$$

Where:

ΔH_i = Differential static pressure (venturi inlet minus venturi throat) for venturi i .

5. You may apply any of the following simplifying assumptions or develop other values as appropriate for your test configuration, consistent with good engineering judgment:

- a. For raw exhaust, diluted exhaust, and dilution air, you may assume that the gas mixture behaves as an ideal gas: $Z = 1$.
- b. For raw exhaust, you may assume $\gamma = 1.385$.
- c. For dilution air, you may assume $\gamma = 1.399$.
- d. For dilution air, you may assume a constant molar mass of the wet air for all calibration and all testing as long as your assumed molar mass differs no more than ± 1 percent from the estimated minimum and maximum molar mass during calibration and testing. You may assume this, using good engineering judgment, if you sufficiently control the amount of water in calibration air and in dilution air or if you remove sufficient water from both calibration air and dilution air. The following table gives examples of permissible ranges of dilution air dewpoint versus calibration air dewpoint:

If calibration T_{dew} ($^{\circ}\text{C}$)	assume the following constant M_{mix} (g/mol)	For the following ranges of T_{dew} during emissions tests
0	28.89263	Dry to 21
5	28.8648	Dry to 22
10	28.81911	Dry to 24
15	28.76244	Dry to 26
20	28.68685	-8 to 28
25	28.58806	12 to 31
30	28.46005	23 to 34

Table B-1 Examples of dilution air and calibration air dewpoints at which you may assumed a constant M_{mix}

6. The following example illustrates the use of the governing equations to calculate C_d of a typical sample venturi flow meter at one reference flow meter value.

Example 2:

$$\dot{n}_{\text{ref}} = 0.01144 \text{ mol/sec}$$

$$Z_1 = 1$$

$$M_1 = 28.92 \text{ g/mol} = 0.02892 \text{ kg/mol}$$

$$R = 8.314472 \text{ J/(mol-K)} = 8.314472 \text{ (m}^2\text{-kg)/(sec}^2\text{-mol-K)}$$

$$T_1 = 293.15 \text{ K}$$

$$A_{t1} = 0.00001570 \text{ m}^2$$

$$P_i = 98.605 \text{ kPa} = 98605 \text{ Pa} = 98605 \text{ kg/(m-sec}^2)$$

$$\gamma_1 = 1.399$$

$$\beta_1 = 0.2$$

$$\Delta H_1 = 2.017 \text{ kPa}$$

$$r_1 = 1 - \frac{2.017}{98.605} = 0.998$$

$$C_{f1} = \left[\frac{2 \times 1.399 \times \left(0.998^{\frac{1.399-1}{1.399}} - 1 \right)}{(1.399-1) \times \left(0.2^4 - 0.998^{\frac{-2}{1.399}} \right)} \right]^{\frac{1}{2}} = 0.06423$$

$$C_{d1} = 0.0144 \times \frac{\sqrt{1 \times 0.02892 \times 8.314472 \times 293.15}}{0.06423 \times 0.00001570 \times 98605} = 0.9666$$

2.3 Venturi calibration (subsonic venturis)

Perform the following steps to calibrate a subsonic venturi flow meter:

1. Calculate the Reynolds number, N_{Re} , for each reference molar flow rate, \dot{n}_{ref} , using the throat diameter of the venturi, d_t . Because the dynamic viscosity, μ , is needed to compute N_{Re} , you may use your own fluid viscosity model to determine μ for your calibration gas (usually air), using good engineering judgment. Use the viscosity model as shown in the following sample calculation for N_{Re} to approximate μ :

$$N_{Rei} = \frac{4 \times M_i \times \dot{n}_{ref}}{\pi \times d_{ti} \times \mu_i} \quad \text{Equation B-6}$$

$$\mu_i = C_1 + C_2 \times \sqrt{T_i} + C_3 \times T_i^{-2} + C_4 \times (\%O_{2i,wet}) - C_5 \times B_{wi} + C_6 \times B_{wi} \times T_i^2 \quad \text{Equation B-7}$$

Where

$$C_1 = -150.3162 \text{ (micropoise)}$$

$$C_2 = 18.0614 \text{ (micropoise/K}^{0.5}) = 13.4622 \text{ (micropoise/}^\circ\text{R}^{0.5})$$

$$C_3 = 1.19183 \times 10^6 \text{ (micropoise/K}^2) = 3.86153 \times 10^6 \text{ (micropoise/}^\circ\text{R}^2)$$

$$C_4 = 0.591123 \text{ (micropoise)}$$

$$C_5 = 91.9723 \text{ (micropoise)}$$

$$C_6 = 4.91705 \times 10^{-5} \text{ (micropoise/K}^2) = 1.51761 \times 10^{-5} \text{ (micropoise/}^\circ\text{R}^2)$$

B_{wi} = water vapor fraction (mole/mole) at venturi i

T_i = gas temperature at inlet of venturi i

Example 3:

$$\%O_{21,wet} = 20.6\%$$

$$B_{w1} = 0.012$$

$$T_1 = 293.15 \text{ K}$$

$$\mu_1 = -150.3162 + 18.0614 \times \sqrt{293.15} + 1.19183 \times 293.15^{-2} + C_4 \times (0.012) - 91.9723 \times 0.012 + 4.91705 \times 0.012 \times 293.15^2 = 183.9 \text{ micropoise} = 1.839 \times 10^{-5} \frac{\text{kg}}{\text{m sec}}$$

$$M_1 = 28.92 \text{ g/mol} = 0.02892 \text{ kg/mol}$$

$$\dot{n}_1 = 0.01144 \text{ mol/s}$$

$$d_{t1} = 4.47 \text{ mm} = 0.00447 \text{ m}$$

$$T_1 = 293.15 \text{ K}$$

$$N_{Re1} = \frac{4 \times 0.02892 \times 0.01144}{3.14159 \times 0.00447 \times 1.839 \times 10^{-5}} = 5.124 \times 10^3$$

[Equation B8 is deleted.]

2. Create an equation for C_d as a function of N_{Re} , using paired values of the two quantities. The equation may involve any mathematical expression, including a polynomial or a power series. The following equation is an example of a commonly used mathematical expression for relating C_d and N_{Re} :

$$C_d = a_0 + a_1 \times \sqrt{\frac{10^6}{N_{Re}}} \quad \text{Equation B-9}$$

3. Create a table of paired values for the calibration C_d values (C_{dref}), the values of $\sqrt{\frac{10^6}{N_{Re}}}$ and the C_d values calculated using the mathematical expression in step 2 above (C_{ddest}).

4. Calculate the least squares regression slope, a_{1y} , as follows:

$$a_1 = \frac{\sum_{j=1}^N (C_{dj} - \bar{C}_d) \times (y_{refj} - \bar{y}_{ref})}{\sum_{j=1}^N (y_{refj} - \bar{y}_{ref})^2} \quad \text{Equation B-10}$$

Where:

C_{dj} = the value of C_d for the j^{th} calibration flow rate;

\bar{C}_d = the average value of C_d for N calibration flow rates;

y_{refj} = the value of $\sqrt{\frac{10^6}{N_{Re}}}$ for the j^{th} calibration flow rate;

\bar{y}_{ref} = the average value of $\sqrt{\frac{10^6}{N_{Re}}}$ for N calibration flow rates.

Example 4:

$N = 12$

$C_{d1} = 0.9229$

$\bar{C}_d = 0.9605$

$y_{ref1} = 24.0998$

$\bar{y}_{ref} = 15.5502$

$$a_1 = \frac{(0.9229 - 0.9605) \times (24.0998 - 15.5502) + \dots + (C_{d12} - 15.5502)}{(24.0998 - 15.5502)^2 + \dots + (y_{ref12} - 15.5502)^2} = -0.004673$$

5. Calculate the least squares regression intercept, a_{0y} , as follows

$$a_0 = \bar{C}_d - (a_1 \times \bar{y}_{ref}) \quad \text{Equation B-11}$$

Example 5:

$$a_0 = 0.9605 - (-0.004673 \times 15.5502) = 1.03188$$

6. Calculate the standard error of estimate, SEE, as follows:

$$SEE = \sqrt{\frac{\sum_{j=1}^N [C_{d1} - a_0 - (a_1 \times y_{refj})]^2}{N-2}} \quad \text{Equation B-12}$$

Example 6:

$$SEE = \sqrt{\frac{[0.9229 - 1.03188 - ((-0.004673) \times 24.0998)]^2 + \dots + [C_{d12} - 1.03188 - ((-0.004673) \times y_{ref12})]^2}{N-2}} = 0.005037$$

7. If the equation meets the criterion of $SEE \leq 0.5$ percent $\times C_{dmax}$, you may use the equation for the corresponding range of N_{Re} , as described in Section 3 below.
8. If the equation does not meet the specified statistical criterion, you may use good engineering judgment to omit calibration data points; however you must use at least seven calibration data points to demonstrate that you meet the criterion. For example, this may involve narrowing the range of flow rates for a better curve fit.
9. Take corrective action if the equation does not meet the specified statistical criterion even after omitting calibration data points. For example, select another mathematical expression for the Cd versus $Re\#$ equation, check for leaks, or repeat the calibration process. If you must repeat the calibration process, we recommend applying tighter tolerances to measurements and allowing more time for flows to stabilize.

10. Once you have an equation that meets the specified statistical criterion, you may use the equation only for the corresponding range of $Re\#$.

3 Venturi flow meter molar flow rate calculations

1. Calculate venturi flow meter molar flow rate, \dot{n}_i , as follows:

$$\dot{n}_i = C_{di} \times C_{fi} \times \frac{A_t \times P_i}{\sqrt{Z_i \times M_i \times R \times T_i}} \quad \text{Equation B-13}$$

Where:

C_{di} = discharge coefficient for venturi i , as determined based on the C_d versus N_{Re} equation in Paragraph 2.2(d)(2) of this Appendix.

C_{fi} = flow coefficient for venturi i , as determined in Paragraph 2.2(3) of this Appendix.

A_{ti} = throat cross-sectional area for venturi i .

P_i = static absolute pressure at the venturi inlet for venturi i .

Z_i = compressibility factor for gas at venturi i .

M_i = molar mass of gas at venturi i .

R = molar gas constant.

T_i = absolute temperature at the venturi inlet for venturi i .

Example 7:

$$A_t = 0.00001570 \text{ m}^2$$

$$P_i = 98.605 \text{ kPa} = 98605 \text{ Pa} = 98605 \text{ kg}/(\text{m} \cdot \text{sec}^2)$$

$$Z_i = 1$$

$$M_i = 28.92 \text{ g/mol} = 0.02892 \text{ kg/mol}$$

$$R = 8.314472 \text{ J}/(\text{mol} \cdot \text{K}) = 8.314472 \text{ (m}^2 \cdot \text{kg)} / (\text{sec}^2 \cdot \text{mol} \cdot \text{K})$$

$$T_i = 293.15 \text{ K}$$

$$N_{Rei} = 0.01144 \text{ mol/sec}$$

$$\gamma_i = 1.399$$

$$\beta_i = 0.2$$

$$\Delta H_i = 2.017 \text{ kPa}$$

$$\text{Using Eq. B-5, } r_i = 0.998$$

$$\text{Using Eq. B-4, } C_{fi} = 0.06423$$

$$\text{Using Eq. B-3, } C_{di} = 0.967$$

$$\dot{n}_i = 0.967 \times 0.06423 \times \frac{0.00001570 \times 98605}{\sqrt{1 \times 0.02892 \times 8.314472 \times 293.15}} = 0.01144 \text{ mol/sec}$$

2. You may convert \dot{n}_i in mol/sec to volumetric flow rate Q_i at any temperature T_i and pressure P_i , in scf/min, re-arranging equation B-1 as follows:

$$Q_{i,std} = \frac{\dot{n}_i \times T_{std} \times R \times 60}{P_{std}} = \frac{C_{di} \times C_{fi} \times A_t \times P_i \times T_{std} \times 60}{P_{std}} \times \sqrt{\frac{R}{Z_i \times M_i \times T_i}}$$

Equation B-14

Example 8, in SI (kg-m-sec) units:

$$\dot{n}_i = 0.01144 \text{ mol/sec}$$

$$T_i = 293.15 \text{ K}$$

$$P_i = 29.9213 \text{ in. Hg} = 101325 \text{ Pa} = 101325 \text{ kg/m-sec}^2$$

$$R = 8.314472 \text{ m}^2\text{-kg/sec}^2\text{-mol-K}$$

$$Q_i = \frac{0.01144 \times 293.15 \times 8.314472}{101325} = 0.000275 \frac{\text{m}^3}{\text{sec}}$$

Example 8, in U.S. Customary units:

$$\dot{n}_i = 0.01144 \text{ mol/sec}$$

$$453.5927 = \text{mol/lbmol}$$

$$60 = \text{sec/min}$$

$$T_i = 528 \text{ }^\circ\text{R}$$

$$P_i = 14.696 \text{ psia} = 14.696 \text{ lbf/in}^2$$

$$R = 1545.35 \text{ ft-lbf/lbmol-}^\circ\text{R} / 144 = 10.73159 \text{ ft}^3\text{-psia/ lbmol-}^\circ\text{R}$$

$$Q_i = \frac{0.01144 \times 528 \times 10.73159 \times 60}{453.5927 \times 14.696} = 0.583 \frac{\text{ft}^3}{\text{min}}$$

4 Venturi calibration correlation for preliminary calculations

To avoid the iterative calculations necessary to calculate target ΔH for a target venturi flow rate in preliminary pre-test calculations, a simplified venturi flow calculation of the following form may be used:

$$Q_i = k_i \times \Delta H_i^{n_i} \times \sqrt{\frac{T_i}{P_i \times M_i}}$$

Equation B-15

Where the regression coefficients k_i and n_i are determined from the calibration data generated in Section 1 of this appendix. This simplified correlation is less accurate and therefore should be used only for determining target ΔH during preliminary pre-test calculations.

