

## Purpose and Scope

The arrangement or layout of a set of charts is called a scheme. It is the systematic configuration of chart "footprints." NOAA is creating a new gridded layout of rectangularly shaped cells for its electronic navigational chart (NOAA ENC®) product suite. This handbook collects the relevant design characteristics for the size, shape and arrangement of reschemed NOAA cells – and a few other key characteristics – that are specified in the Marine Chart Division (MCD) Nautical Chart Manual (NCM). It can serve as a handy reference for information that is spread throughout the NCM. The handbook is intended to be informative, not authoritative. For any conflict between the information in this handbook and the descriptions and specifications of the new ENC scheme in the NCM, the guidance and specifications found in the NCM shall prevail.

The rescheming of each legacy ENC cell is accomplished in several phases, shown in Figure 1. When a reschemed ENC cell is released to the public, it reflects changes and improvements made during one or more of these phases, which may be applied in various orders and combinations. This document only discusses the gridding and metrification portions of the overall ENC rescheming process.

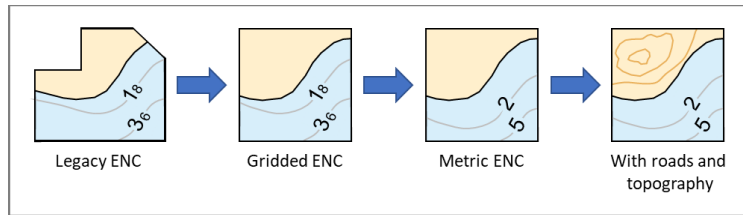

Figure 1. Basic steps of the NOAA ENC rescheming process.

The new scheme for all NOAA ENC may be seen on the [Status of New NOAA ENC](#) webmap, which also shows the ongoing progress of gridding the NOAA ENC product suite. Blue rectangles show planned ENC footprints, red cells are in work, yellow cells in review, and green cells have completed the gridding phase and are available to the public.

### ENC usage bands and standard scales

ENCs are categorized into six usage bands, sometimes called scale bands. The original ENC scheme used over 100 compilation scales ranging from 1:2,500 to 1:10,000,000. The new ENC scheme uses only 12 scales, two for each of the six ENC usage bands, as shown in Table 1.

Table 1. New Standard ENC Compilation Scales.

ENC Usage Band	Navigational Purpose	Standard ENC Scales
1	Overview	1:10,000,000 1:3,500,000
2	General	1:1,500,000 1:700,000
3	Coastal	1:350,000 1:180,000
4	Approach	1:90,000 1:45,000
5	Harbor	1:22,000 1:12,000
6	Berthing	1:4,000 1:2,000

After NOAA established one set of 12 standard compilation scales for the reschemed ENC design, the International Hydrographic Organization finalized the standard minimum and maximum display scales defined in the new S-101 ENC Product Specification, which are shown in Table 1. NOAA ENC (all of which are currently in the old IHO S-57 ENC format) will now transition to the new S-101 scales in preparation for production of both ENC formats starting in 2026.

### Standard ENC cell shape and size

The new ENC layout consists of nested rectangular cells, with boundaries following lines of longitude and latitude. Sixteen larger scale ENC cells fit inside one cell of the next smaller scale band. Figure 2 shows how 16 band 3 cells (green squares) fit inside one band 2 cell (brown square) and the relative sizes of cells in other bands. Figure 3 shows an example of nested, reschemed cells in bands 2 through 5 covering the California Coast from San Francisco to the Channel Islands.

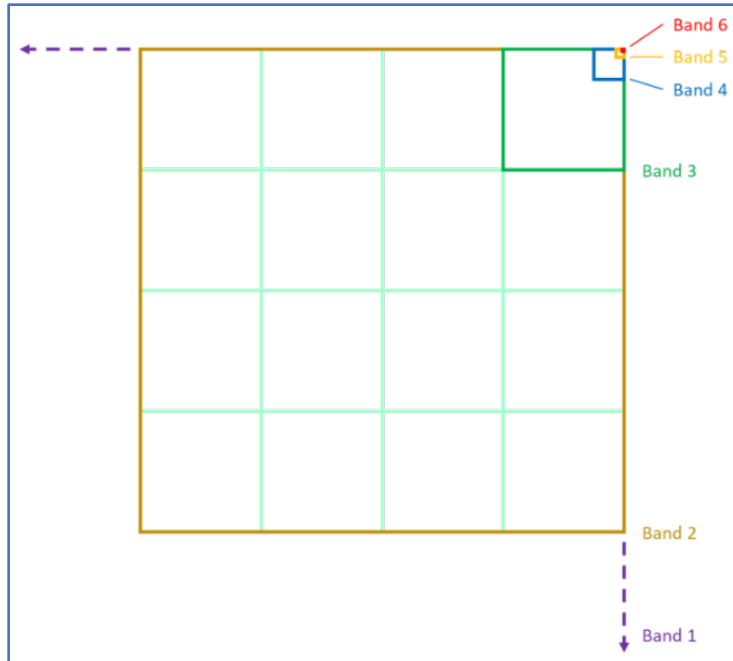

Figure 2. Nesting of reschemed ENC cells.

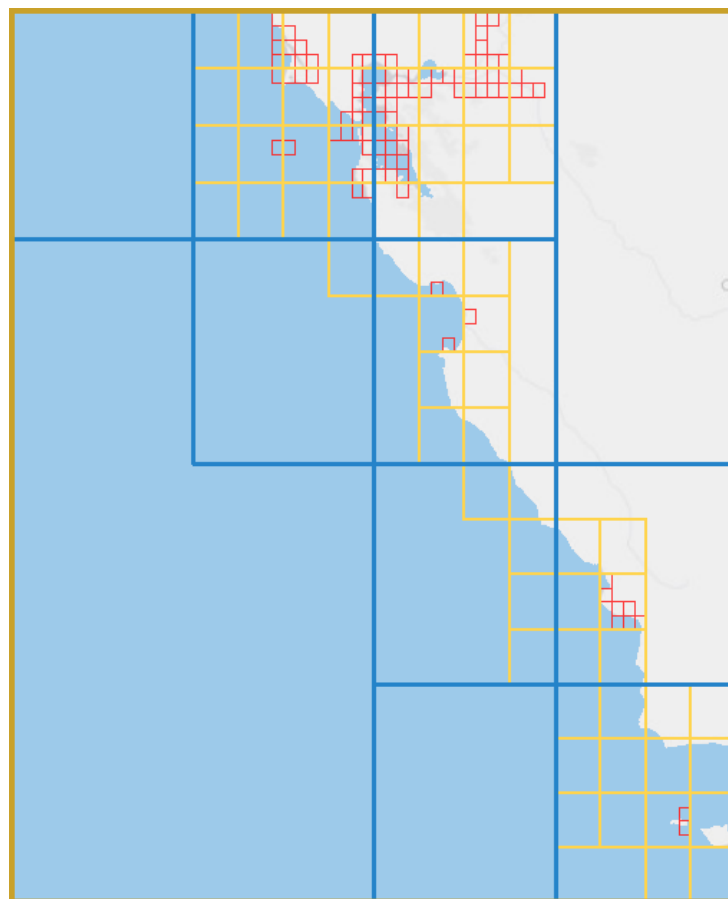

Figure 3. Reschemed ENC cells along the California coast, band 2 (brown), band 3 (blue), band 4 (yellow), and band 5 (red).

### Latitude-based ENC cell width

On the globe, lines of longitude – also called meridians – converge at the Poles. Thus, the area of the Earth covered by ENC cells defined by equal extents of latitude and longitude will be narrower for ENC cells further away from the Equator. Reschemed ENC cells take this narrowing into account. Cells closer to the poles are widened by increasing their longitudinal extent as a multiple of their height.

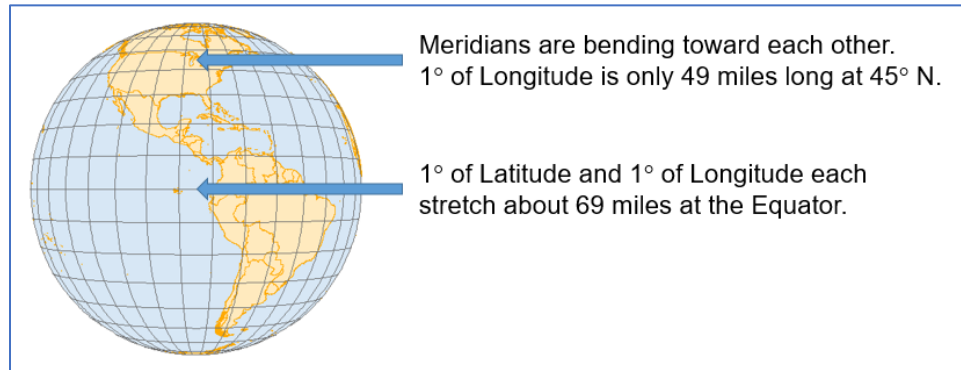

Figure 4. Distance between meridians decreases as they converge at the poles.

The reschemed ENC design calls for cells to be wider longitudinally as they get closer to the poles, so the extent of the coverage "on the ground" doesn't become too narrow. For bands 3-5, the width of reschemed ENC cells is specified by their location within three zones of latitude, as shown in Figure 5. The assignment of zones for bands 1 and 2 are determined by a different method, but they use the same multiples of height. The extents of band 6 cells are established on a case-by-case basis and may not follow the widths specified in Table 2.

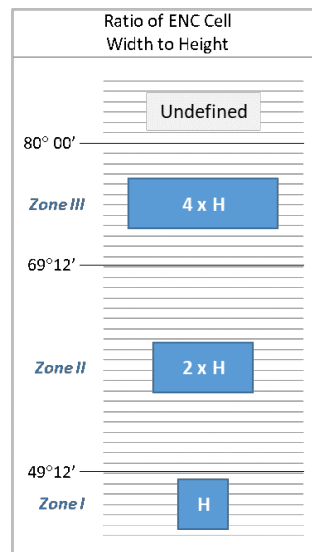

Figure 5. Latitudinal zones used to specify the widths of band 3-5 ENC cells, as a multiple of height (H).

Table 2 shows cell widths in decimal degrees of longitude, for each zone, for each usage band. Cell dimensions are the same for both of the two standard scales in each usage band. For example, the height of all band 3 ENC cells is 1.2° in latitude. Band 3 cells below 49° 12' N fall into Zone I and have a cell width equal to their height, or 1.2° in longitude. Band 3 cells falling between 49° 12' N and 69° 12' N are in Zone II and have a width of twice their height, or 2.4° in longitude. The width of cells falling in Zone III is four times their height, or 4.8° in longitude.

Table 2. New Standard ENC Cell Dimensions.

Usage Band	Navigational Purpose	Standard Scales	Height	Zone I Width = H	Zone II Width = 2xH	Zone III Width = 4xH
1 [1]	Overview	1:10,000,000 1:3,500,000	19.2°	19.2°	38.4°	76.8°
2 [2]	General	1:1,500,000 1:700,000	4.8°	4.8°	9.6°	19.2°
3	Coastal	1:350,000 1:180,000	1.2°	1.2°	2.4°	4.8°
4	Approach	1:90,000 1:45,000	0.3°	0.3°	0.6°	1.2°
5	Harbor	1:22,000 1:12,000	0.075°	0.075°	0.15°	0.3°
6 [3]	Berthing	1:4,000 1:2,000	0.0375°	0.0375°	0.075°	0.15°

Table notes:

[1] Band 1 ENCs will be some of the last cells created as part of the rescheming effort and their final configuration has not yet been established.

[2] All band 2 ENCs within the contiguous 48 states are considered to be in Zone I. Band 2 ENCs west of Washington State in the North Pacific are considered to be in Zone II, except for ENCs in Alaska covering Point Hope, the North Slope and the Arctic Sea, which are considered Zone III.

[3] The extents of band 6 ENCs are established on a case-by-case basis and are generally smaller than the standard sizes shown in Table 2. Most band 6 cells retain the size and shape of the legacy paper charts from which they were originally digitized, but are nevertheless considered to be part of the "reschemed" ENC product suite.

### Naming Convention for NOAA Reschemed ENC Cells

All ENC file names throughout the world consist of eight characters; the first two characters hold the producer code, as listed in the International Hydrographic Organization (IHO) [S-62, List of IHO Data Producer Codes](#) – "US" is the NOAA producer code. The third character is the ENC usage band number (1 - 6). The remaining five characters of the file name are defined differently by various ENC producers. For NOAA ENCs, characters 4 through 6 hold a regional reference code and characters 7 and 8 hold the cell's matrix position within its region.

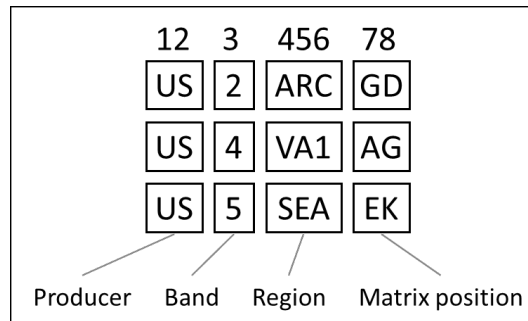

Figure 6. Three examples of the components of an 8-character reschemed ENC cell name: a band 2 cell in the Arctic, a band 4 cell in Virginia, and a band 5 cell covering the Port of Seattle.

There are several types of regional codes (see Annex A for a complete list). All NOAA band 1 cells are in the Global region and use the code "GLB." Regions for band 2 cells are based on oceans, other large

water bodies, and the two polar regions, such as Pacific (PAC), Great Lakes (GRL), and Arctic (ARC). Regions in bands 3 and 4 are based primarily on US Postal Service two-letter abbreviations for US states and territories and a few other designations, such as Cuba (CU), Antarctic Treaty (AQ), and US Minor Outlying Islands (UM), which includes Howland Island and Johnston Atoll. After the two-letter abbreviations, the number 1 usually makes up the final part of the three-character regional code. If a region is large, it will be broken into smaller parts – especially in band 4, such as California, which has CA1 and CA2. The final type of regional code – used in bands 5 and 6 in addition to state and territory codes – is based on principal port names, such as Boston (BOS), Seattle (SEA), and Ketchikan (KTN). These three-character port identifiers are from the [UN LOCODE Code List by Country and Territory](#).

The final two characters of the ENC file name indicate a cell's position within its region's matrix of cells. The cell in the southwestern corner of each region is designated as "AA." The first letter of the pair is incremented for each additional cell moving northward and the second letter is incremented for each additional cell moving eastward in the matrix, as shown in Figure 7. Each region can hold a maximum of 676 cells in the 26 x 26 matrix.

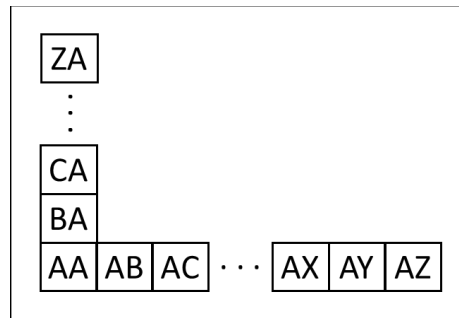

Figure 7. The last two characters in an ENC name describe a cell's position within its region.

### Standardized metric depth contours

When NOAA digitized paper charts to create the first NOAA ENCs, depth values for soundings, depth curves, and other features with depths were converted from the fathoms and feet shown on the charts to meters, to populate the ENC database. The ENC product specification established by the IHO requires depths to be stored as metric values. However, depth contours continued to reflect the intervals in which they were originally compiled. Thus, depth contours in older ENC data displayed in meters will show fractional metric values resulting from the unit conversion from feet to meters, as shown in the image below.

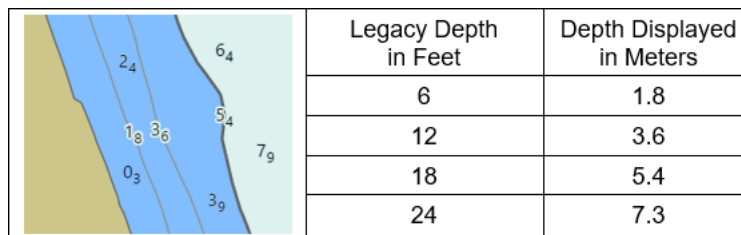

Figure 8. Example of depth contours compiled in feet and displayed in meters.

When the ENC rescheming project is complete, all depth contours will be compiled in whole metric units. However, most newly reschemed ENC cells will not be recompiled in their initial release (first edition) of the cell. The image below shows examples of whole 2, 5, 10, 20, and 50-meter depth contours. The depth value of soundings will also be stored and displayed with a higher degree of

precision than available on paper charts. Soundings less than 30 meters deep are stored and displayed as meters with subscripts in tenths of meters (decimeters) – a granularity smaller than 4 inches.

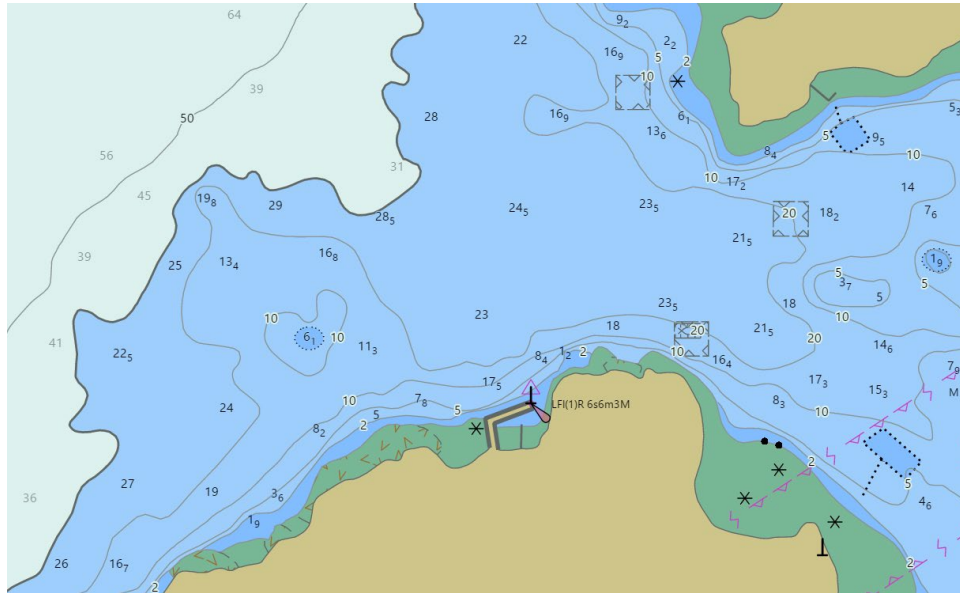

Figure 9. Depiction of metric ENC depth contours.

Table 3 shows the standard depth contours that may be used in reschemed ENCs for each usage band. These are based on depth intervals specified in the IHO S-101 ENC Product Specification ("Depth area" section of the IHO S-101, ENC Product Specification, Annex A, Data Classification and Encoding Guide). Intervals used for a particular ENC will be based on the relief found within that cell. For larger scale ENCs, depth contours for 3, 4, 6, 7, and 8 meters will only be compiled in areas with a gently sloping bottom. In areas with extremely steep bathymetry, the 2 and 5 meter contours may also be omitted.

Table 3. Standard Metric Depth Contour Intervals. Optional values are shown in gray.

Usage Band	Navigational Purpose	Compilation Scale	Depth Contours (meters)																								
			2	3	4	5	6	7	8	10	15	20	30	50	100	150	200	300	400	500	...						
1	Overview	1:10,000,000																									
		1:3,500,000																									
2	General	1:1,500,000																									
		1:700,000																									
3	Coastal	1:350,000																									
		1:180,000																									
4	Approach	1:90,000																									
		1:45,000																									
5	Harbor	1:22,000																									
		1:12,000																									
6	Berthing	1:4,000																									
		1:2,000																									

## Annex A: Regional Codes

Some codes, especially in band 6, are not currently used.

Region	Code	Band
Global	GLB	1

Region	Code	Band
Arctic	ARC	2
Antarctic	ANT	2
Atlantic	ATL	2
Great Lakes	GRL	2
Gulf of Mexico	GOM	2
Pacific	PAC	2

Region	Code	Band
Alaska	AK1	3
Alabama	AL1	3
American Samoa	AS1	3
California	CA1	3
Connecticut	CT1	3
Cuba	CU1	3
Florida	FL1	3
Georgia	GA1	3
Guam	GU1	3
Hawaii	HI1	3
Illinois	IL1	3
Indiana	IN1	3
Louisiana	LA1	3
Massachusetts	MA1	3
Maryland	MD1	3
Maine	ME1	3
Michigan	MI1	3
Minnesota	MN1	3
Mississippi	MS1	3
North Carolina	NC1	3
New Hampshire	NH1	3
New Jersey	NJ1	3
New York	NY1	3
Ohio	OH1	3
Oregon	OR1	3
Pennsylvania	PA1	3
Puerto Rico	PR1	3
Rhode Island	RI1	3
South Carolina	SC1	3
Texas	TX1	3
US Minor 1	UM1	3
US Minor 2	UM2	3
Virginia	VA1	3
Washington	WA1	3
Wisconsin	WI1	3

Region	Code	Band
Alaska 1	AK1	4
Alaska 2	AK2	4
Alaska 3	AK3	4
Alaska 4	AK4	4
Alaska 5	AK5	4
Alaska 6	AK6	4
Alaska 7	AK7	4
Alabama	AL1	4
American Samoa	AS1	4
Antarctic Treaty 1	AQ1	4
Antarctic Treaty 2	AQ2	4
California 1	CA1	4
California 2	CA2	4
Connecticut	CT1	4
Delaware	DE1	4
Florida 1	FL1	4
Florida 2	FL2	4
Georgia	GA1	4
Guam 1	GU1	4
Guam 2	GU2	4
Hawaii 1	HI1	4
Hawaii 2	HI2	4
Hawaii 3	HI3	4
Hawaii 4	HI4	4
Idaho	ID1	4
Illinois	IL1	4
Indiana	IN1	4
Louisiana	LA1	4
Massachusetts	MA1	4
Maryland	MD1	4
Maine	ME1	4
Michigan 1	MI1	4
Michigan 2	MI2	4
Minnesota	MN1	4
Mississippi	MS1	4
North Carolina	NC1	4
New Hampshire	NH1	4
New Jersey	NJ1	4
Nevada 1	NV1	4
Nevada 2	NV2	4
New York 1	NY1	4
New York 2	NY2	4
Ohio	OH1	4
Oregon	OR1	4
Pennsylvania	PA1	4
Puerto Rico	PR1	4



Region	Code	Band
Rhode Island	RI1	4
South Carolina	SC1	4
Texas	TX1	4
US Minor 1	UM1	4
US Minor 2	UM2	4
US Minor 3	UM3	4
US Minor 4	UM4	4
US Minor 5	UM5	4
US Minor 6	UM6	4
Virginia	VA1	4
Virgin Islands	VI1	4
Washington	WA1	4
Wisconsin	WI1	4

Region	Code	Band
Alaska 11	A1K	5
Alaska 12	A2K	5
Alaska 13	A3K	5
Alaska 14	A4K	5
Alaska 10	AK0	5
Alaska 1	AK1	5
Alaska 2	AK2	5
Alaska 3	AK3	5
Alaska 4	AK4	5
Alaska 5	AK5	5
Alaska 6	AK6	5
Alaska 7	AK7	5
Alaska 8	AK8	5
Alaska 9	AK9	5
Alabama	AL1	5
Anchorage, AK	ANC	5
Alpena, MI	APN	5
New Iberia, LA	ARA	5
American Samoa 1	AS1	5
American Samoa 2	AS2	5
American Samoa 3	AS3	5
Antarctic Treaty	AQ1	5
Baltimore, MD	BAL	5
Bridgeport, CT	BDR	5
Bangor, ME	BGR	5
Biloxi, MS	BIX	5
Boston, MA	BOS	5
Baton Rouge, LA	BPG	5
Beaumont, TX	BPT	5
Brownsville, TX	BRO	5
Buffalo, NY	BUF	5
California 1	CA1	5
California 2	CA2	5
California 3	CA3	5

Region	Code	Band
California 4	CA4	5
California 5	CA5	5
California 6	CA6	5
Conneaut, OH	CDY	5
Chicago, IL	CHI	5
Charleston, SC	CHS	5
Cleveland, OH	CLE	5
Port Angeles, WA	CLM	5
Coos Bay, OR	COB	5
Corpus Christi, TX	CRP	5
Connecticut	CT1	5
District of Columbia	DC1	5
Delaware	DE1	5
Detroit, MI	DET	5
Duluth, MN	DLH	5
Drummond Island, MI	DRE	5
Escanaba, MI	ESC	5
Fall River, MA	FAV	5
Florida 1	FL1	5
Florida 2	FL2	5
Florida 3	FL3	5
Florida 4	FL4	5
Florida 5	FL5	5
Florida 6	FL6	5
Florida 7	FL7	5
Florida 8	FL8	5
Fond du Lac, WI	FLD	5
Flemington, NJ	FLE	5
Flatrock, MI	FLF	5
Foley, FL	FLS	5
Flat, AK	FLT	5
Franklin, WI	FLW	5
Fort Bragg, CA	FOB	5
Fourchon, LA	FOC	5
Freeport, TX	FPO	5
Fairport Harbor, OH	FPT	5
Georgia 1	GA1	5
Georgia 2	GA2	5
Grays Harbor, WA	GHC	5
Gulfport, MS	GPT	5
Green Bay, WI	GRB	5
Guam 1	GU1	5
Guam 2	GU2	5
Guam 3	GU3	5
Guam 4	GU4	5
Gulliver, MI	GUV	5
Hempstead, NY	HEP	5
Hingham, MT	HGG	5
Hawaii 1	HI1	5

Region	Code	Band
Hawaii 2	HI2	5
Hawaii 3	HI3	5
Hawaii 4	HI4	5
Hawaii 5	HI5	5
Hawaii 6	HI6	5
Hawaii 7	HI7	5
Hawaii 8	HI8	5
Honolulu, HI	HNL	5
Houston, TX	HOU	5
Hopewell, VA	HPW	5
Houma, LA	HUM	5
New Haven, CT	HVN	5
Illinois	IL1	5
Wilmington, DE	ILG	5
Wilmington, NC	ILM	5
Ithaca, NY	ITH	5
Hilo, HI	ITO	5
Jacksonville, FL	JAX	5
Juneau, AK	JNU	5
Lakeside Marblehead, OH	KDB	5
Kinsman, IL	KFM	5
Kawaihae, HI	KHW	5
Ketchikan, AK	KTN	5
Kivalina, AK	KVL	5
Louisiana 1	LA1	5
Louisiana 2	LA2	5
Louisiana 3	LA3	5
Laguna Beach, CA	LAX	5
Lancaster, NY	LAC	5
La Mesa, CA	LAE	5
Lake Charles, LA	LCH	5
Long Beach, CA	LGB	5
Morgan City, LA	LMO	5
Lorain, OH	LOR	5
Port of South Louisiana, LA	LU8	5
Massachusetts	MA1	5
Maryland	MD1	5
Maine 1	ME1	5
Maine 2	ME2	5
Maine 3	ME3	5
Manatee, FL	MEE	5
Moffett Field, CA	MEF	5
Mehoopany, PA	MEH	5
Matagorda Island, TX	MGI	5
Michigan 1	MI1	5
Michigan 2	MI2	5
Michigan 3	MI3	5
Michigan 4	MI4	5
Michigan 5	MI5	5

Region	Code	Band
Michigan 6	MI6	5
Michigan 7	MI7	5
Miami, FL	MIA	5
Milwaukee, WI	MKE	5
Muskegon, MI	MKG	5
Minnesota	MN1	5
Mobile, AL	MOB	5
Morehead City, NC	MRH	5
Mississippi	MS1	5
New Orleans, LA	MSY	5
North Carolina 1	NC1	5
North Carolina 2	NC2	5
New Hampshire	NH1	5
Nawiliwili, HI	NIJ	5
New Jersey	NJ1	5
Nikishka, AK	NQK	5
Port Hueneme, CA	NTD	5
New York 1	NY1	5
New York 2	NY2	5
New York 3	NY3	5
New York 4	NY4	5
New York 5	NY5	5
New York 6	NY6	5
New York 9	NY9	5
New York City, NY	NYC	5
Oakland, CA	OAK	5
Kahului, HI	OGG	5
Olympia, WA	OLM	5
Oregon 1	OR1	5
Oregon 2	OR2	5
Norfolk, VA	ORF	5
Orange, TX	ORG	5
Pennsylvania	PA1	5
Palm Beach, FL	PAB	5
Pittsburg, CA	PBG	5
Port Canaveral, FL	PCV	5
Portland, OR	PDX	5
Port Everglades, FL	PEF	5
Panama City, FL	PFN	5
Pascagoula, MS	PGL	5
Philadelphia, PA	PHL	5
Plaquemine, LA	PLQ	5
Port Lavaca, TX	PLV	5
Pensacola, FL	PNS	5
Port Arthur, TX	POA	5
Puerto Rico 1	PR1	5
Puerto Rico 2	PR2	5
Ponce, PR	PSE	5
Portsmouth, NH	PSM	5

Region	Code	Band
Presque Isle, MI	PSS	5
Port Jefferson, NY	PTJ	5
Providence, RI	PVD	5
Portland, ME	PWM	5
Rhode Island	RI1	5
San Diego, CA	SAN	5
Savannah, GA	SAV	5
South Carolina 1	SC1	5
South Carolina 2	SC2	5
Seattle, WA	SEA	5
San Juan, PR	SJU	5
Brunswick, GA	SSI	5
Toledo, OH	TOL	5
Tampa, FL	TPA	5
Texas 1	TX1	5
Texas 2	TX2	5
Texas 3	TX3	5
Texas City, TX	TXT	5
Unalaska Island, AK	UAA	5
US Minor 1	UM1	5
US Minor 2	UM2	5
US Minor 3	UM3	5
US Minor 4	UM4	5
US Minor 5	UM5	5
US Minor 6	UM6	5
Virginia	VA1	5
Victoria, TX	VCT	5
Valdez, AK	VDZ	5
Virgin Islands	VI1	5
Vermont	VT1	5
Washington 1	WA1	5
Washington 2	WA2	5
Washington 3	WA3	5
Washington 4	WA4	5
Washington 5	WA5	5
Wisconsin 1	WI1	5
Wisconsin 2	WI2	5
Watkins Glen, NY	WKG	5
Yakutat, AK	YAK	5

Region	Code	Band
Marine City, MI	2TT	6
Albany, NY	ALB	6
Anchorage, AK	ANC	6
Alpena, MI	APN	6
New Iberia, LA	ARA	6
Ashtabula, OH	ASF	6
Baltimore, MD	BAL	6
Bridgeport, CT	BDR	6

Region	Code	Band
Bangor, ME	BGR	6
Biloxi, MS	BIX	6
Burns Harbor, IN	BNB	6
Boston, MA	BOS	6
Baton Rouge, LA	BPG	6
Beaumont, TX	BPT	6
Brownsville, TX	BRO	6
Buffalo, NY	BUF	6
Camden-Gloucester, NJ	CDE	6
Conneaut, OH	CDY	6
Chicago, IL	CHI	6
Charleston, SC	CHS	6
Chester, PA	CHT	6
Cleveland, OH	CLE	6
Port Angeles, WA	CLM	6
Coos Bay, OR	COB	6
Corpus Christi, TX	CRP	6
Detroit, MI	DET	6
Duluth, MN	DLH	6
Drummond Island, MI	DRE	6
East Chicago, IN	ECH	6
Escanaba, MI	ESC	6
Fall River, MA	FAV	6
Fort Bragg, CA	FOB	6
Fourchon, LA	FOC	6
Freeport, TX	FPO	6
Fairport Harbor, OH	FPT	6
Grays Harbor, WA	GHC	6
Grand Haven, MI	GHN	6
Galveston, TX	GLS	6
Gulfport, MS	GPT	6
Green Bay, WI	GRB	6
Gulliver, MI	GUV	6
Gary, IN	GYG	6
Hempstead, NY	HEP	6
Honolulu, HI	HNL	6
Houston, TX	HOU	6
Hopewell, VA	HPW	6
New Haven, CT	HVN	6
Brunswick, GA	IDC	6
Wilmington, DE	ILG	6
Wilmington, NC	ILM	6
Ithaca, NY	ITH	6
Hilo, HI	ITO	6
Jacksonville, FL	JAX	6
Juneau, AK	JNU	6
Kalama, WA	KAM	6
Lakeside Marblehead, OH	KDB	6
Kinsman, IL	KFM	6

Region	Code	Band
Kawaihae , HI	KHW	6
Ketchikan, AK	KTN	6
Kivalina, AK	KVL	6
Laguna Beach, CA	LAX	6
Lake Charles, LA	LCN	6
Long Beach, CA	LGB	6
Longview, WA	LOG	6
Lorain, OH	LOR	6
Port of South Louisiana, LA	LU8	6
Marcus Hook, PA	MAH	6
Manatee, FL	MEE	6
Matagorda Island, TX	MGI	6
Calcite, MI	MI3	6
Miami, FL	MIA	6
Milwaukee, WI	MKE	6
Muskegon, MI	MKG	6
Mobile, AL	MOB	6
Monroe, MI	MOI	6
Marquette, MI	MQT	6
Morehead City, NC	MRH	6
New Orleans, LA	MSY	6
Barbers Point, Oahu, HI	NAX	6
New Castle, DE	NCD	6
Nawiliwili, HI	NIJ	6
Nikishka, AK	NQK	6
Port Hueneme, CA	NTD	6
New York City, NY	NYC	6
Oakland, CA	OAK	6
Kahului, HI	OGG	6
Olympia, WA	OLM	6
Norfolk, VA	ORF	6
Palm Beach, FL	PAB	6
Everett, WA	PAE	6
Paulsboro, NJ	PAU	6
Port Canaveral, FL	PCV	6

Region	Code	Band
Portland, OR	PDX	6
Port Everglades, FL	PEF	6
Panama City, FL	PFN	6
Pascagoula, MS	PGL	6
Philadelphia, PA	PHL	6
Plaquemines, LA	PLQ	6
Pensacola, FL	PNS	6
Port Arthur, TX	POA	6
Ponce, PR	PSE	6
Portsmouth, NH	PSM	6
Presque Isle, MI	PSS	6
Port Jefferson, NY	PTJ	6
Providence, RI	PVD	6
Portland, ME	PWM	6
Richmond, CA	RCH	6
Redwood City, CA	RWC	6
San Diego, CA	SAN	6
Savannah, GA	SAV	6
Stockton, CA	SCK	6
St. Clair, MI	SCL	6
Sandusky, OH	SDW	6
Seattle, WA	SEA	6
San Francisco, CA	SFO	6
Silver Bay, MN	SIB	6
San Juan, PR	SJU	6
Two Harbors, MN	THB	6
Tacoma, WA	TIW	6
Toledo, OH	TOL	6
Tampa, FL	TPA	6
Texas City, TX	TXT	6
Unalaska Island, AK	UAA	6
Vancouver, WA	VAN	6
Victoria, TX	VCT	6
Valdez, AK	VDZ	6