

**U.S. DEPARTMENT OF TRANSPORTATION  
NATIONAL HIGHWAY TRAFFIC SAFETY ADMINISTRATION**

**CALIBRATION TEST PROCEDURE  
for  
Part 572 Subpart S  
HIII 6-Year-Old Weighted Child Test Dummy**



**ENFORCEMENT  
Office of Vehicle Safety Compliance  
Mail Code: NVS-220, W43-481  
1200 New Jersey Avenue, SE  
Washington, DC 20590**

## TABLE OF CONTENTS

1. PURPOSE AND APPLICATION .....	4
2. GENERAL REQUIREMENTS.....	4
3. SECURITY .....	5
4. GOOD HOUSEKEEPING .....	5
5. TEST SCHEDULING AND MONITORING .....	6
6. TEST DATA DISPOSITION.....	6
7. GOVERNMENT FURNISHED PROPERTY (GFP).....	6
8. CALIBRATION AND TEST INSTRUMENTATION.....	6
9. DEFINITIONS.....	7
10. INSTRUMENTATION, TEST CONDITIONS, AND PROCEDURES.....	8
10.1 INSTRUMENTATION.....	8
10.2 GENERAL TEST CONDITIONS .....	10
10.3 HEAD ASSEMBLY.....	11
10.4 NECK.....	14
10.5 THORAX.....	18
10.6 TORSO ASSEMBLIES AND FLEXION TEST.....	21
10.7 KNEE (572.166).....	23
11. CALIBRATION TEST EXECUTION.....	26
12. POSTTEST REQUIREMENTS.....	26
13. REPORTS .....	26
14. DATA SHEETS.....	29
DUMMY DAMAGE CHECKLIST .....	29
EXTERNAL MEASUREMENTS .....	31
HEAD DROP TEST (572.162).....	38
NECK FLEXION TEST (572.163).....	40
NECK EXTENSION TEST (572.163) .....	42

THORAX IMPACT TEST (572.164).....	44
TORSO FLEXION TEST (572.165).....	47
LEFT KNEE IMPACT TEST (572.166).....	49
RIGHT KNEE IMPACT TEST (572.166).....	51
PART 572 INSTRUMENTATION CALIBRATION INFORMATION.....	53
APPENDIX A: 6YO HIII STORAGE CHAIR DRAWING PACKAGE.....	54

### **LIST OF FIGURES**

FIGURE 1. SIGN CONVENTION FOR PART 572 TEST DUMMIES .....	10
FIGURE 2. HEAD ASSEMBLY TEST .....	13
FIGURE 3. HEAD-NECK ASSEMBLY FLEXION TEST SET-UP.....	16
FIGURE 4. HEAD-NECK ASSEMBLY EXTENSION TEST SET-UP.....	17
FIGURE 5. PENDULUM FOR NECK TEST .....	18
FIGURE 6. THORAX IMPACT TEST SET-UP .....	21
FIGURE 7. TORSO FLEXION TEST.....	23
FIGURE 8. KNEE IMPACT TEST .....	25
FIGURE 9. EXTERNAL DIMENSIONS OF 6YO HIII CHILD TEST DUMMY .....	35
FIGURE 10. EXTERNAL DIMENSIONS TEST SET UP .....	36
FIGURE 11. EXTERNAL DIMENSIONS TEST SETUP – SIDE VIEW.....	37
FIGURE 12. PART 572S HYBRID III-6W THORAX CALIBRATION – HYSTERESIS .....	46

### **LIST OF TABLES**

TABLE 1. DRAWING PACKAGE INDEX .....	5
TABLE 2. SIGN CONVENTION FOR HYBRID III TRANSDUCER OUTPUTS .....	11
TABLE 3. ACCELERATION VS. TIME FOR NECK PENDULUM .....	15

## 1. PURPOSE AND APPLICATION

The purpose of this laboratory procedure is to provide dummy users (independent testing laboratories under contract with the Office of Vehicle Safety Compliance) with standard test procedures for performing receiving-inspection and performance calibration tests on the Part 572, Subpart S dummy so that repetitive and correlative test results can be obtained. The following tests have been developed to establish a uniform calibration procedure for all users as the means of verifying the performance of the dummy.

- A. EXTERNAL DIMENSIONS (drawing 167-0000 sheet 5 of 6, & PADI)
- B. HEAD DROP TEST (572.162)
- C. NECK FLEXION TEST (572.163)
- D. NECK EXTENSION TEST 572.163)
- E. THORAX IMPACT TEST ((572.164)
- F. TORSO FLEXION (572.165)
- G. KNEE IMPACT TESTS (572.166)

This laboratory procedure for the calibration of Part 572, Subpart S dummies must be used by National Highway Traffic Safety Administration (NHTSA) contract laboratories performing FMVSS 213 testing for the Office of Vehicle Safety Compliance (OVSC).

## 2. GENERAL REQUIREMENTS

The Code of Federal Regulations (49CFR), Parts 571 and 572, was amended to adopt the Hybrid III, 6-Year-Old Child Weighted Dummy as the means of determining a Child Restraint System's (CRS's) conformance to the performance requirements of FMVSS 213. Each Part 572, Subpart S dummy used in a compliance test must meet the specifications and performance criteria of Part 572 before each test in order to be an acceptable compliance test tool. However, the Subpart S dummy's instrumentation will not be used to determine compliance with a federal motor vehicle safety standard. The dummy may be used to collect data for use in research. Accordingly, this test procedure includes calibration test procedures for instrumentation. The COTR will determine when post-test calibrations are necessary.

The Part 572, Subpart S Hybrid III, 6-Year-Old Child Weighted Dummy consists of components and assemblies specified in the drawing and specifications package which is available from [www.regulations.gov](http://www.regulations.gov) under Docket No. NHTSA-2010-0147 and containing the following materials:.

(1) A drawings and specifications package entitled, "Parts List and Drawings, Part 572 Subpart S, Hybrid III 6-Year-Old Child Weighted Crash Test Dummy (H-III6CW)," dated June 2009, incorporated by reference in §572.161 which includes the engineering drawings and specifications described in Drawing 167-0000, the titles of the assemblies of which are listed in Table 1, and,:

(2) A procedures manual entitled, "Procedures for Assembly, Disassembly, And Inspection (PADI) of the Part 572 Subpart S, Hybrid III 6-Year-Old Child Weighted Crash Test Dummy (H-III6CW), revised June 2009,"

TABLE 1. DRAWING PACKAGE INDEX

Assembly	Drawing No.
(i) Complete Assembly	167-0000
(ii) Upper Torso Assembly	167-2000
(iii) Spine Box Weight	167-2020
(iv) Lower Torso Assembly	167-3000
(v) Lumbar Weight Base	167-3010

### 3. SECURITY

All NHTSA Part 572, Subpart S test dummies delivered to the contract laboratory as Government Furnished Property (GFP) will be stored in a safe and secure area such as the dummy calibration laboratory. The contractor is financially responsible for any acts of theft and/or vandalism which occur during the storage of GFP. Any security problems shall be reported by telephone to the Industrial Property Manager (IPM), Office of Contracts and Procurement, within two working days after the incident. A letter containing specific details of the security problem will be sent to the IPM (with copy to the COTR) within 48 hours.

The contractor is responsible for maintaining the NHTSA test dummies in good working order, and shall protect and segregate the data that evolves from conducting Part 572, Subpart S dummy calibration tests before and after each compliance test.

No information concerning the Part 572, Subpart S dummy calibration data shall be released to anyone except the COTR, unless specifically authorized by the COTR or the COTR's Branch or Division Chief.

**NOTE:** No individuals, other than contractor personnel directly involved in the dummy calibration test program, shall be allowed to witness dummy calibration tests unless specifically authorized by the COTR.

### 4. GOOD HOUSEKEEPING

Contractors shall maintain the entire dummy calibration laboratory, test fixtures, and instrumentation in a neat, clean, and painted condition with test instruments arranged in an orderly manner consistent with good test laboratory housekeeping practices.

## **5. TEST SCHEDULING AND MONITORING**

The Part 572, Subpart S dummies are being calibrated as test tools to be used in determining compliance with the requirements of federal motor vehicle safety standards. The schedule for these performance calibration tests must be correlated with that of the compliance test schedule. All testing shall be coordinated to allow monitoring by the COTR.

## **6. TEST DATA DISPOSITION**

The contractor shall make all dummy calibration data available to the COTR for review and analysis as required.

All backup data sheets, strip charts, recordings, plots, technicians notes, etc. shall be either sent to the COTR or destroyed at the conclusion of each delivery order, purchase order, etc.

## **7. GOVERNMENT FURNISHED PROPERTY (GFP)**

Part 572, Subpart S test dummies will be furnished to the contract laboratory by the OVSC. The dummies shall be stored in an upright sitting position with the weight supported by the internal structure of the pelvis. The dummies head shall be held upright by using a strap around the chest or the base of the neck so that the neck is not supporting the weight of the dummy. An example of a storage chair is included in Appendix A. These dummies shall be stored in a secured room that is kept between 55°F and 85°F. The contractor will check dummy components for damage after each crash test and complete a dummy damage checklist that will be included with the posttest dummy calibration. The COTR will be kept informed of the dummies condition in order that replacement parts can be provided.

## **8. CALIBRATION AND TEST INSTRUMENTATION**

Before the contractor initiates the dummy performance calibration test program, a test instrumentation calibration system must be implemented and maintained in accordance with established calibration practices. The calibration system shall be set up and maintained as follows:

- A. Standards for calibrating the measuring and test equipment shall be stored and used under appropriate environmental conditions to assure their accuracy and stability.
- B. All measuring instruments and standards shall be calibrated by the contractor, or a commercial facility, against a higher order standard at periodic intervals not exceeding 6 months for instruments and 12 months for calibration standards. Records, showing the calibration traceability to the National Institute of Standards

and Technology (NIST), shall be maintained for all measuring and test equipment.

C. All measuring and test equipment and measuring standards shall be labeled with the following information:

- (1) Date of calibration
- (2) Date of next scheduled calibration
- (3) Name of the technician who calibrated the equipment

D. The contractor shall provide a written calibration procedure that includes, as a minimum, the following information for all measurement and test equipment:

- (1) Type of equipment, manufacturer, model number, etc.
- (2) Measurement range
- (3) Accuracy
- (4) Calibration interval
- (5) Type of standard used to calibrate the equipment (calibration traceability of the standard must be evident)
- (6) The actual procedures and forms used to perform calibrations.

E. The contractor shall keep records of calibrations for all test instrumentation in a manner that assures the maintenance of established calibration schedules. All such records shall be readily available for inspection when requested by the COTR. The calibration system will need the written acceptance of the COTR before testing begins.

F. Test equipment shall receive a calibration check immediately prior to each test. This check shall be recorded by the test technician(s) and made available if requested by the COTR.

## **9. DEFINITIONS**

PADI- Procedures for Assembly, Disassembly, and Inspection

## 10. INSTRUMENTATION, TEST CONDITIONS, AND PROCEDURES

### 10.1 INSTRUMENTATION

#### 10.1.1 TRANSDUCERS REQUIRED FOR QUALIFICATION TESTS

The test conditions and instrumentation are as specified in 49 CFR 572.127 (Subpart N). (572.167)

The contractor shall provide and install the following instrumentation<sup>1</sup> to the GFP dummies.

- A. HEAD – The head accelerometers shall have dimensions, response characteristics and sensitive mass locations specified in drawing SA572-S4 and be mounted in the head as shown in drawing 127-0000 sheet 3. (572.127(c))

Three accelerometers shall be mounted in the head cavity to measure orthogonal accelerations (Ax, Ay, Az) at the center of gravity (CG) of the head assembly.

- B. NECK – The upper neck force transducer shall have the dimensions, response characteristics, and sensitive axis locations specified in drawing SA572-S11 and shall be mounted in the head neck assembly as shown in drawing 127-0000, sheet 3. (572.127(d))
- C. CHEST – The chest accelerometers shall have the dimensions, response characteristics, and sensitive mass locations specified in drawing SA572-S4 and be mounted in the torso assembly in triaxial configuration at T4 as shown in drawing 127-0000 sheet 3. The chest accelerometers are not required for dummy calibration testing but are required for FMVSS 213 CRS testing. (572.127(e))

The chest deflection transducer shall have the dimensions and response characteristics specified in drawing SA572-S50 and be mounted to the upper torso assembly as shown in drawing 127-0000 sheet 3. (572.127(f))

- D. TEST FIXTURE – The neck pendulum, thorax and knee probe accelerometers shall have the dimensions and characteristics of drawing SA572-S4.

---

<sup>1</sup> Excluding the chest deflection potentiometer



## 10.1.2 TRANSDUCER TEST CONDITIONS

- A. TRANSDUCER MOUNTS – The mountings for sensing devices shall have no resonance frequency less than 3 times the frequency range of the applicable channel class. (572.127(m))
- B. TRANSDUCER SIGN CONVENTION - The sign convention for outputs of transducers mounted within the dummy that measure head and chest accelerations, chest deflection and femur loads are located in Figure 1 and Table 1G. For other transducers see SAE J1733DEC94. (572.127(l))
- C. TRANSDUCER OUTPUTS and FILTERING - The outputs of acceleration and force-sensing devices installed in the dummy and in the test apparatus specified by this part are recorded with individual data channels. Each data channel will be comprised of a sensor, signal conditioner, data acquisition device, and all interconnecting cables, and must conform to the requirements of SAE Recommended Practice J211/1 MAR95, "Instrumentation for Impact Test," with channel classes as follows: (572.127(k))

(1) Head acceleration	Class 1000 (572.127(k)(1))
(2) Neck force	Class 1000 (572.127(k)(2)(i))
(3) Neck pendulum acceleration	Class 180 (572.127(k)(2)(iii))
(4) Neck moment transducers	Class 600 (572.127(k)(2)(ii))
(5) Thorax and thorax pendulum acceleration	Class 180 (572.127(k)(3)(ii))
(6) Sternum deflection	Class 600 (572.127(k)(3)(iii))
(7) Knee pendulum acceleration	Class 600
(8) Femur force	Class 600 (572.127(k)(6))
(9) Torso flexion	Class 60

All filter classes should be of the "phaseless" type to be compatible with the "time" dependent test parameters.

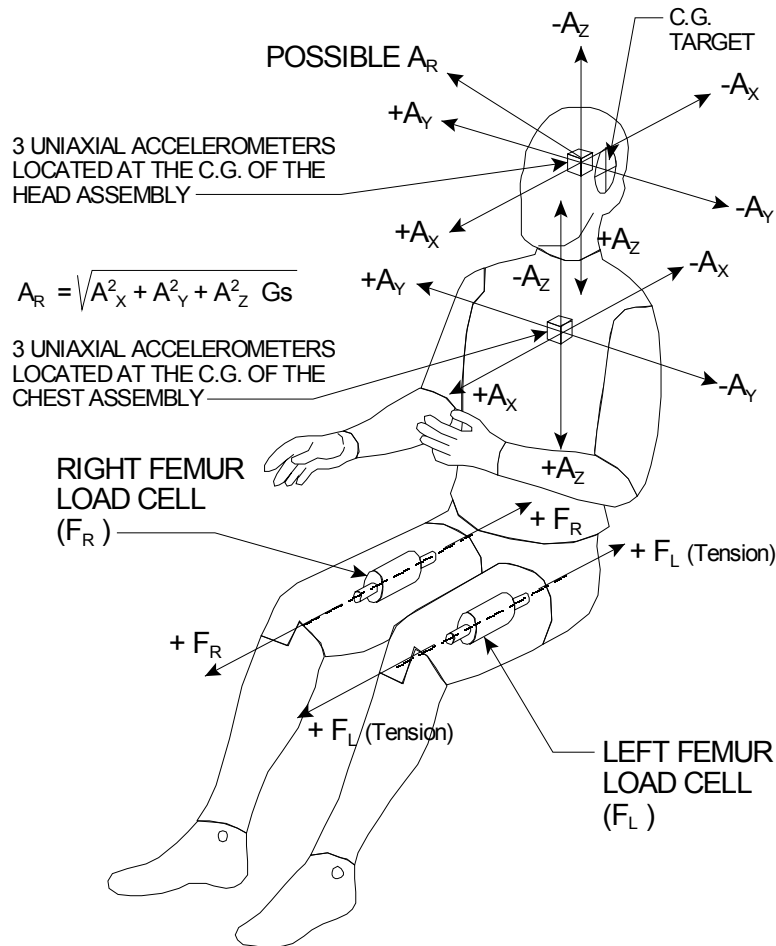

**FIGURE 1. SIGN CONVENTION FOR PART 572 TEST DUMMIES**

## 10.2 GENERAL TEST CONDITIONS

- A. Surfaces of dummy components are not painted unless otherwise specified. (572.127(p))
- B. Dummy performance tests of the same component, segment, assembly, or fully assembled dummy are separated in time by a period of not less than 30 minutes unless otherwise specified. (572.127(o))
- C. Except for neck assembly and thorax assembly testing, the dummy performance tests are conducted at any temperature from 18.9oC (66°F) to 25.6oC (78°F) and at any relative humidity from 10% to 70% after exposure of the dummy to these conditions for a period of not less than 4 hours. For the neck assembly and thorax assembly, the temperature range is 20.6oC (69°F) to 22.2oC (72°F)
- D. Dummy limb joints are set at 1G, barely restraining the weight of the limb when it is extended horizontally. The force required to move a limb segment does not exceed 2 G throughout the range of limb motion. (572.127(n))

TABLE 2. SIGN CONVENTION FOR HYBRID III TRANSDUCER OUTPUTS

BODY SEGMENT — MEASURED FORCE	POSITIVE OUTPUT DIRECTION
NECK FX SHEAR FY SHEAR FZ AXIAL  MX MOMENT (ROLL) MY MOMENT (PITCH) MZ MOMENT (YAW)	HEAD REARWARD OR CHEST FORWARD HEAD LEFTWARD, CHEST RIGHTWARD HEAD UPWARD, CHEST DOWNWARD  LEFT EAR TOWARD LEFT SHOULDER CHIN TOWARD STERNUM CHIN TOWARD LEFT SHOULDER
FEMUR FX SHEAR FY SHEAR FZ AXIAL  MX MOMENT (ROLL) MY MOMENT (PITCH) MZ MOMENT (YAW)	KNEE UPWARD, UPPER FEMUR DOWNWARD KNEE RIGHTWARD, UPPER FEMUR LEFTWARD KNEE FORWARD (TENSION), PELVIS REARWARD  KNEE LEFTWARD, HOLD UPPER FEMUR IN PLACE KNEE UPWARD, HOLD UPPER FEMUR IN PLACE KNEE ROTATED CCW WHEN FACING FRONT OF DUMMY
KNEE CLEVIS - FZ AXIAL	TIBIA DOWNWARD (TENSION), FEMUR UPWARD
UPPER TIBIA MX MOMENT MY MOMENT	ANKLE LEFTWARD, HOLD KNEE IN PLACE ANKLE FORWARD, BOTTOM OF KNEE CLEVIS REARWARD
LOWER TIBIA FX SHEAR FY SHEAR FZ AXIAL  MX MOMENT MY MOMENT	ANKLE FORWARD, KNEE REARWARD ANKLE RIGHTWARD, KNEE LEFTWARD ANKLE DOWNWARD (TENSION), KNEE UPWARD  ANKLE LEFTWARD, HOLD KNEE IN PLACE ANKLE FORWARD, BOTTOM OF KNEE CLEVIS REARWARD
CHEST DISPLACEMENT	CHEST COMPRESSED - NEGATIVE
KNEE SHEAR DISPLACEMENT	PUSH ON FRONT OF TIBIA - NEGATIVE

**NOTE:** DIRECTIONS ARE DEFINED IN RELATION TO A SEATED DUMMY

### 10.3 HEAD ASSEMBLY

#### 10.3.1 TEST SET-UP (572.122(c))

The test set up for the head assembly test is shown in Figure 2.

The impact surface is a rigidly supported flat horizontal steel plate which is 50.8 mm (2 in) thick and 610 mm (24 in) square. The surface shall be clean, dry and have a micro finish of

not less than  $203.2 \times 10^{-6}$  mm (8 micro inches) (RMS) and not more than  $2032.0 \times 10^{-6}$  mm (80 micro inches) (RMS).

#### 10.3.2 COMPONENTS FOR HEAD ASSEMBLY TEST (572.122(a))

The head assembly for this test consists of the complete head (drawing 127-1000), a six-axis neck transducer (drawing SA572-S11) or its structural replacement (drawing 78051-383X), a head to neck-to-pivot pin (drawing 78051-339), and 3 accelerometers (drawing SA572-S4).

#### 10.3.3 HEAD ASSEMBLY CALIBRATION REQUIREMENT (572.122(b))

When the head assembly is dropped from a height of  $376.0 \pm 1.0$  mm ( $14.8 \pm 0.04$  in), the peak resultant acceleration at the head CG may not be less than 245 G or more than 300 G. The resultant acceleration vs. time history curve shall be unimodal; oscillations occurring after the main pulse must be less than 10 percent of the peak resultant acceleration. The lateral acceleration shall not exceed 15 g (zero to peak).

#### 10.3.4 HEAD ASSEMBLY TEST PROCEDURE (572.122(c))

- (1) Soak the head assembly at any temperature between 18.9 and 25.6 °C (66 and 78 °F) and a relative humidity from 10 to 70 percent for at least four hours.
- (2) Clean the impact surface of the skin and the impact plate surface with isopropyl alcohol, trichloroethane, or an equivalent. Allow the head to dry.
- (3) Suspend the head assembly as shown in Figure 2. The lowest point on the forehead must be  $376.0 \pm 1.0$  mm ( $14.8 \pm 0.04$  in) from the impact surface and the head must be oriented to an incline of  $62 \pm 1$  deg. between the "D" plane as shown in Figure 2 and the plane of the impact surface. The 1.57 mm (0.062 in) diameter holes located on either side of the dummy's head shall be used to ensure that the head is level with respect to the impact surface.
- (4) Drop the head assembly from the specified height by means that ensure a smooth, instant release onto the impact surface.
- (5) Allow at least 2 hours between successive tests on the same head.

## HEAD DROP TEST SET-UP SPECIFICATIONS

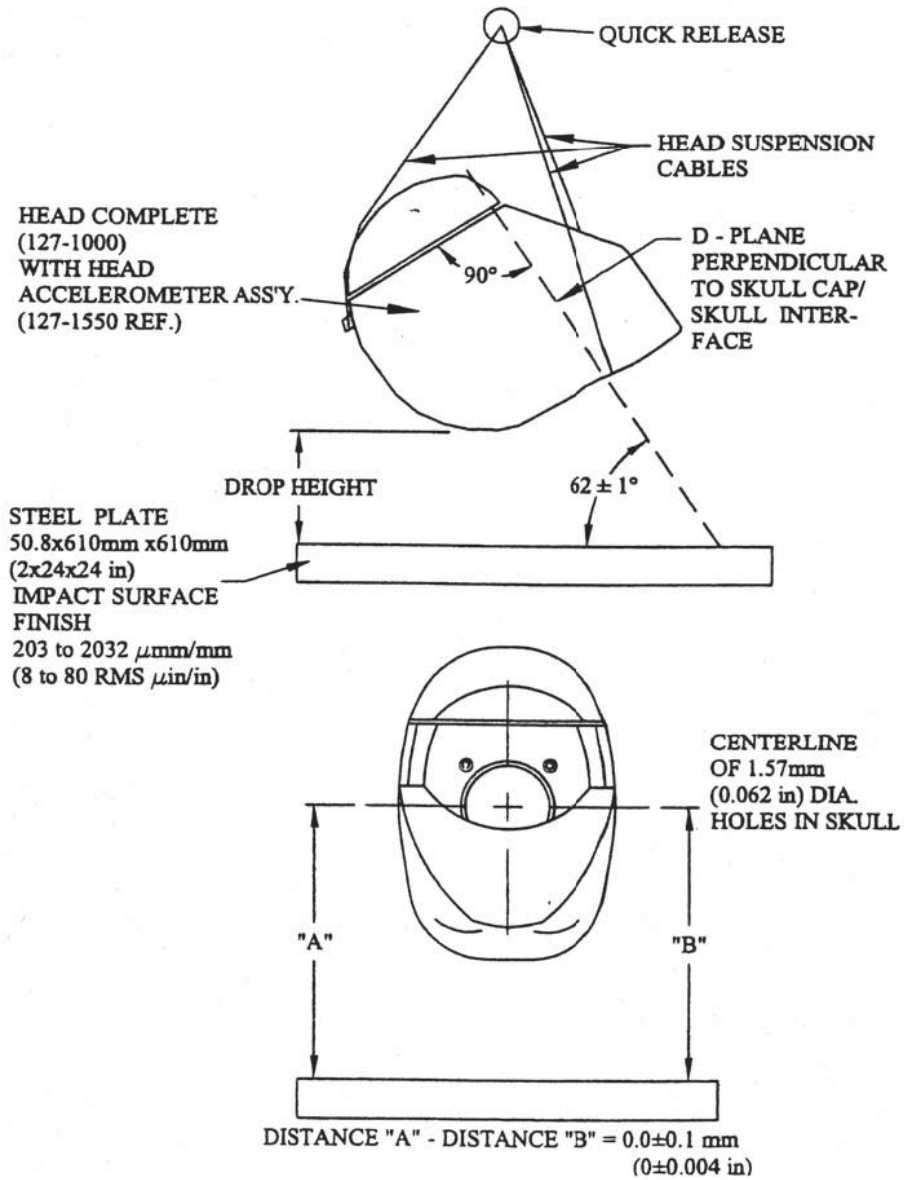

**FIGURE 2. HEAD ASSEMBLY TEST**

## 10.4 NECK

### 10.4.1 TEST SET-UP

The test set up for the neck assembly calibration is shown in Figures 3 and 4. The pendulum required for the test is described in Figure 5.

### 10.4.2 COMPONENTS FOR NECK TEST (572.123(b))

For the purpose of this test, the head-neck assembly consists of the head (drawing 127-1000), neck (drawing 127-1015), pivot pin (drawing 78051-339), bib simulator (drawing TE127-1025), neck bracket assembly (drawing 127-8221), six-axis neck transducer (drawing SA572-S11), neck mounting adaptor (drawing TE-2208-001), and three accelerometers (drawing SA572-S4) installed in the head assembly.

Refer to the PADI (see Section 2 for information on locating the PADI) for assembly and disassembly instructions.

### 10.4.3 NECK CALIBRATION REQUIREMENT (572.123(b))

The head-neck assembly shall have the following characteristics:

#### A. Flexion

- (1) Plane D, referenced in Figure 3, shall rotate in the direction of preimpact flight with respect to the pendulum's longitudinal centerline between 74 degrees and 92 degrees. Within this specified rotation corridor, the peak moment about the occipital condyles shall be not less than 27 N-m (19.9 ft-lbf) and not more than 33 N-m (24.3 ft-lbf).
- (2) The positive moment shall decay for the first time to 5 N-m (3.7 ft-lbf) between 103 ms and 123 ms.
- (3) The moment shall be calculated by the following formula:  $\text{Moment (N-m)} = M_y - (0.01778 \text{ m}) \times (F_x)$ .
- (4)  $M_y$  is the moment about the y-axis and  $F_x$  is the shear force measured by the neck transducer (drawing SA572-S11) and 0.01778 m is the distance from force to occipital condyle.

#### B. Extension

- (1) Plane D, referenced in Figure 4, shall rotate in the direction of preimpact flight with respect to the pendulum's longitudinal centerline between 85 degrees and 103 degrees. Within this specified rotation corridor, the peak moment about the occipital condyles shall be not more than -19 N-m (-14 ft-lbf) and not less than -24 N-m (-17.7ft-lbf).

- (2) The negative moment shall decay for the first time to  $-5 \text{ N}\cdot\text{m}$  ( $-3.7 \text{ ft}\cdot\text{lbf}$ ) between 123 ms and 147 ms.
- (3) The moment shall be calculated by the following formula:  $\text{Moment (N}\cdot\text{m)} = M_y - (0.01778 \text{ m}) \times (F_x)$ .
- (4)  $M_y$  is the moment about the y-axis and  $F_x$  is the shear force measured by the neck transducer (drawing SA572-S11) and 0.01778 m is the distance from force to occipital condyle.

### C. Time zero

$T_0$  is defined as the time of initial contact between the pendulum striker plate and the honeycomb material. All data channels should be at the zero level at this time.

### 10.4.4 NECK TEST PROCEDURE (572.123(c))

- (1) Soak the neck assembly at any temperature between 20.6 and 22.2 °C (69 and 72 °F) and a relative humidity between 10 and 70 percent for at least four hours prior to a test.
- (2) Torque the jam nut (drawing 9000341) on the neck cable (drawing 127-1016) to  $0.23 \pm 0.02 \text{ N}\cdot\text{m}$  ( $2.0 \pm 0.2 \text{ in}\cdot\text{lbs}$ ).
- (3) Mount the head-neck assembly on the pendulum so the midsagittal plane of the head is vertical and coincides with the plane of motion of the pendulum as shown in Figure 3 for flexion tests and Figure 4 for extension tests.
- (4) Release the pendulum and allow it to fall freely from a height to achieve an impact velocity of  $4.95 \pm 0.12 \text{ m/s}$  ( $16.2 \pm 0.4 \text{ ft/s}$ ) for flexion tests and  $4.3 \pm 0.12 \text{ m/s}$  ( $14.10 \pm 0.40 \text{ ft/s}$ ) for extension tests, measured by an accelerometer mounted on the pendulum as shown in Figure 5 at the instant of contact with the honey comb.
- (5) Stop the pendulum from the initial velocity with an acceleration vs. time pulse which meets the velocity change as specified in Table 3. Integrate the pendulum acceleration data channel to obtain the velocity vs. time curve.

TABLE 3. ACCELERATION VS. TIME FOR NECK PENDULUM

Time	Pendulum pulse			
	Flexion		Extension	
	m/s	ft/s	m/s	ft/s
10	1.2-1.6	3.9-5.3	1.0-1.4	3.3-4.6
20	2.4-3.4	7.9-11.2	2.2-3.0	7.2-9.8
30	3.8-5.0	12.5-16.4	3.2-4.2	10.5-13.8

NECK FLEXION TEST SET-UP SPECIFICATIONS

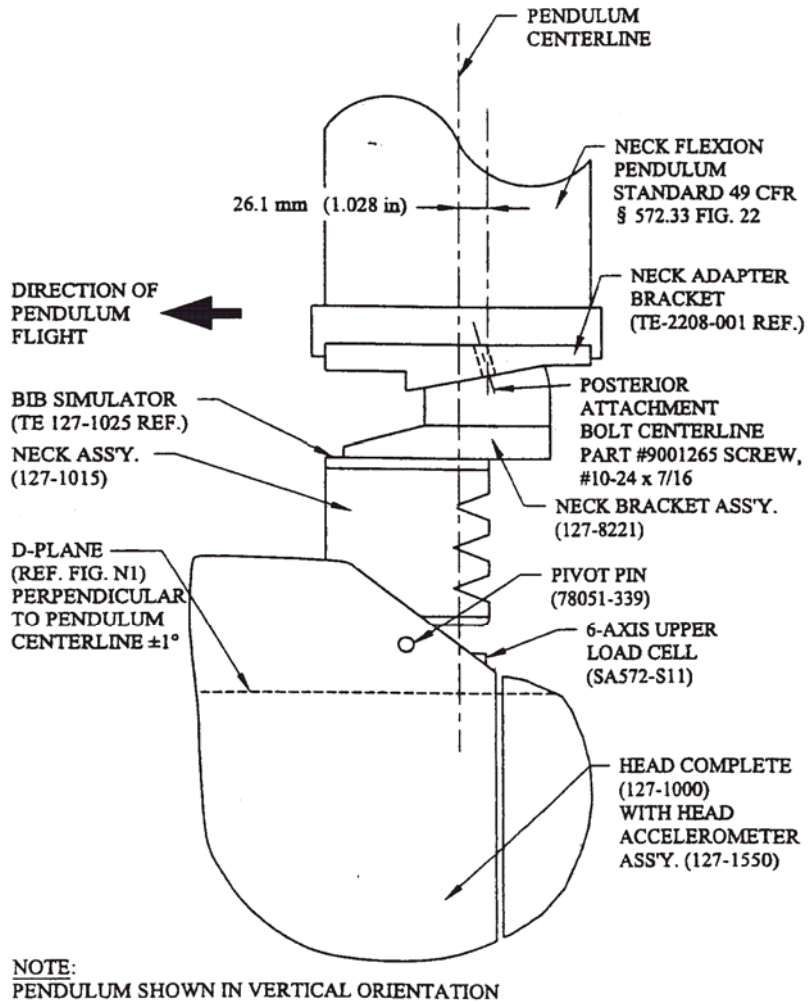

**FIGURE 3. HEAD-NECK ASSEMBLY FLEXION TEST SET-UP**



NECK EXTENSION TEST SET-UP SPECIFICATIONS

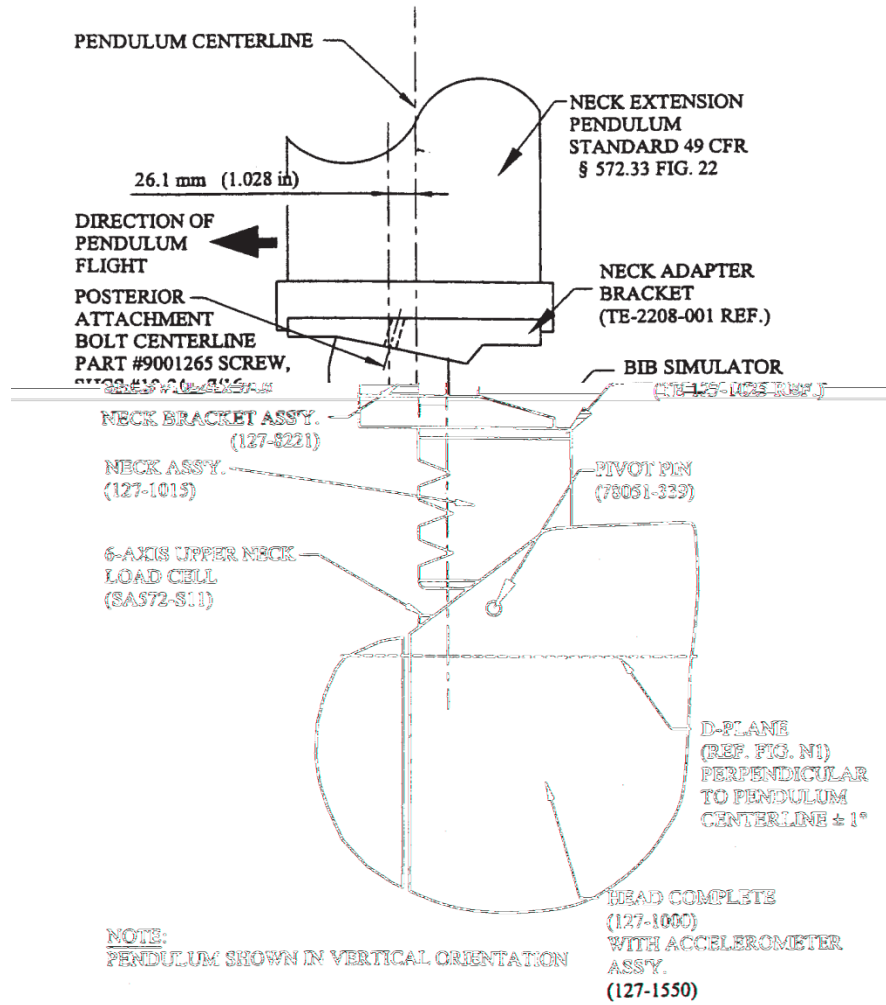

**FIGURE 4. HEAD-NECK ASSEMBLY EXTENSION TEST SET-UP**

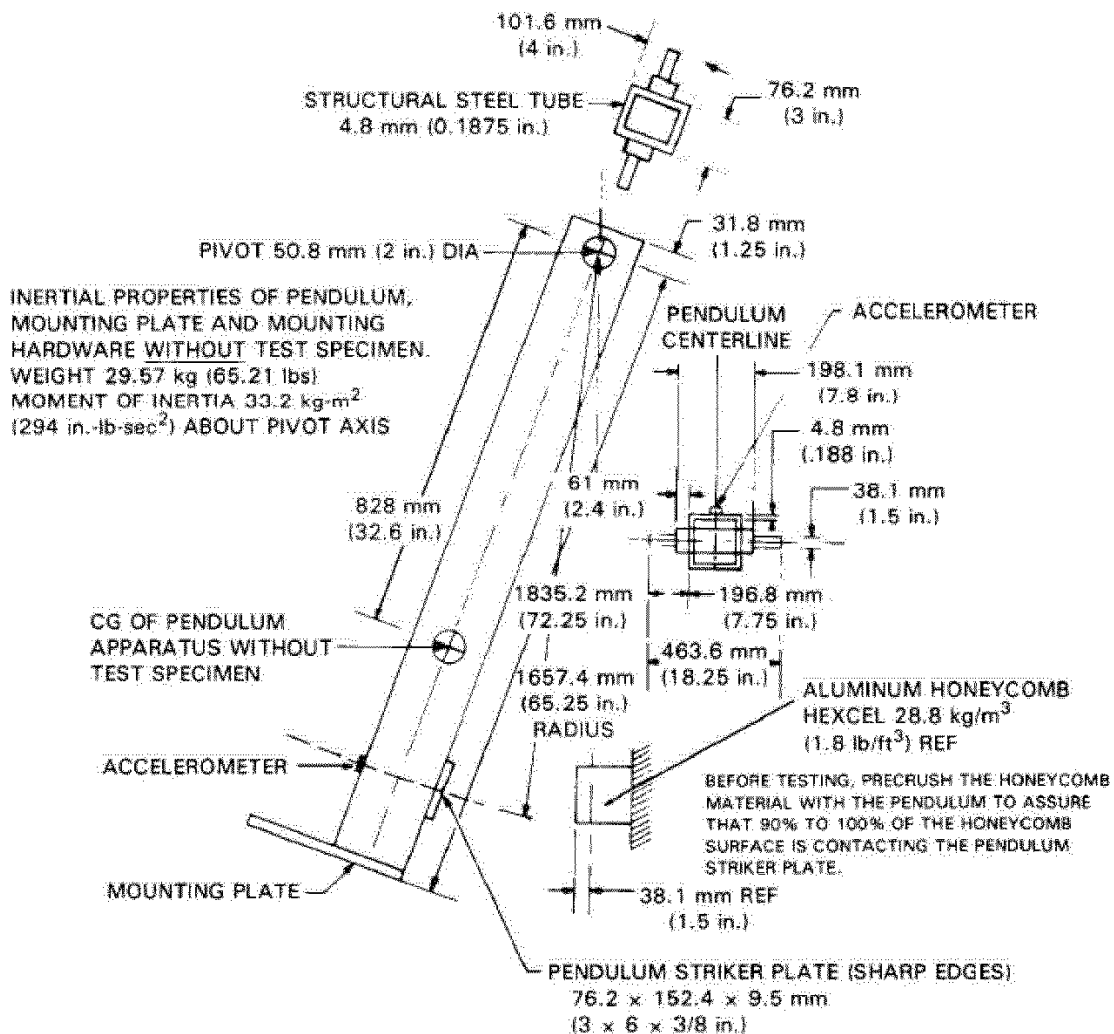

**FIGURE 5. PENDULUM FOR NECK TEST**

10.5 THORAX

10.5.1 TEST SET-UP (572.127(a))

A. THORAX IMPACTOR PROBE

- (1) The test probe for thoracic impacts shall be of rigid metallic construction, concentric about its longitudinal axis.
- (2) It shall have a mass of  $2.86 \pm 0.02$  kg ( $6.3 \pm 0.05$  lbs). 1/3 of the weight of the suspension cables and any attachments to the impact probe must be included in the calculation of mass, and such components may not exceed 5 percent of the total weight of the test probe.

- (3) It shall have a minimum mass moment of inertia of  $160 \text{ kg-cm}^2$  ( $0.141 \text{ lbs-in-sec}^2$ ) in yaw and pitch about the center of gravity.
- (4) The impacting end of the probe is perpendicular to and concentric with the longitudinal axis. It must have a flat, continuous, and non-deformable face with diameter of  $101.6 \pm 0.25 \text{ mm}$  ( $4.00 \pm 0.01 \text{ in}$ ) and an edge radius of  $7.6\text{-}12.7 \text{ mm}$  ( $0.3\text{-}0.5 \text{ in}$ ).
- (5) The impactor is a cylinder with a diameter of  $101\text{-}103 \text{ mm}$  ( $4.0\text{-}4.1 \text{ in}$ ) and it is at least  $12.5 \text{ mm}$  ( $0.5 \text{ in}$ ) long.
- (6) The probe's end opposite to the impact face must have provisions for mounting of an accelerometer with its sensitive axis collinear with the longitudinal axis of the probe.
- (7) The impact probe shall have a free air resonant frequency of not less than  $1000 \text{ Hz}$  in the direction of the longitudinal direction of the impactor.

#### B. DUMMY SEATING SURFACE

The seating surface shall have no back support.

#### 10.5.2 COMPONENTS FOR THORAX TEST

The thorax consists of the part of the torso assembly shown in drawing 167-2000 (572.164(a)).

#### 10.5.3 THORAX CALIBRATION REQUIREMENT (572.164(b))

When the anterior surface of the thorax of a completely assembled dummy (drawing 167-2000) that is seated as shown in Figure 6 is impacted by a test probe conforming to 49 CFR 572.127(a) at  $6.71 \pm 0.12 \text{ m/s}$  ( $22.0 \pm 0.4 \text{ ft/s}$ ) according to the test procedure specified in 49 CFR 572.124(c):

- (1) The maximum sternum displacement relative to the spine, measured with chest deflection transducer (specified in 49 CFR 572.124(b)(1)), must be not less than  $38.0 \text{ mm}$  ( $1.50 \text{ in}$ ) and not more than  $46.0 \text{ mm}$  ( $1.80 \text{ in}$ ). Within this specified compression corridor, the peak force, measured by the probe in accordance with 49 CFR 572.127, must be not less than  $1205 \text{ N}$  ( $270.9 \text{ lbf}$ ) and not more than  $1435 \text{ N}$  ( $322.6 \text{ lbf}$ ). The peak force after  $12.5 \text{ mm}$  ( $0.5 \text{ in}$ ) of sternum displacement, but before reaching the minimum required  $38.0 \text{ mm}$  ( $1.46 \text{ in}$ ) sternum displacement limit, must not exceed an upper limit of  $1500 \text{ N}$ .

- (2) The internal hysteresis of the ribcage in each impact as determined by the plot of force vs. deflection in paragraph (b)(1) of this section must be not less than 65 percent but not more than 85 percent.

#### 10.5.4 THORAX TEST PROCEDURE (572.164(c))

The thorax assembly is tested as specified in 49 CFR 572.124(c).

- (1) Soak the dummy at any temperature between 20.6° and 22.2 °C (69° and 72 °F) and a relative humidity between 10 and 70 percent for at least four hours prior to a test.
- (2) Seat and orient the dummy as shown in Figure 6, with the limbs extended horizontally and forward, parallel to the midsagittal plane, the midsagittal plane vertical within  $\pm 1$  degree and the ribs level in the anterior-posterior and lateral directions within  $\pm 0.5$  degrees.
- (3) Establish the impact point at the chest midsagittal plane so that the impact point of the longitudinal centerline of the probe coincides with the midsagittal plane of the dummy within  $\pm 2.5$  mm (0.1 in) and is  $12.7 \pm 1.1$  mm ( $0.5 \pm 0.04$  in) below the horizontal-peripheral centerline of the No. 3 rib and is within 0.5 degrees of a horizontal line in the dummy's midsagittal plane.
- (4) Impact the thorax with the test probe so that at the moment of contact the probe's longitudinal center line falls within 2 degrees of a horizontal line in the dummy's midsagittal plane.
- (5) Guide the test probe during impact so that there is no significant lateral, vertical or rotational movement.
- (6) No suspension hardware, suspension cables, or any other attachments to the probe, including the velocity vane, shall make contact with the dummy during the test.

## THORAX IMPACT TEST SET-UP SPECIFICATIONS

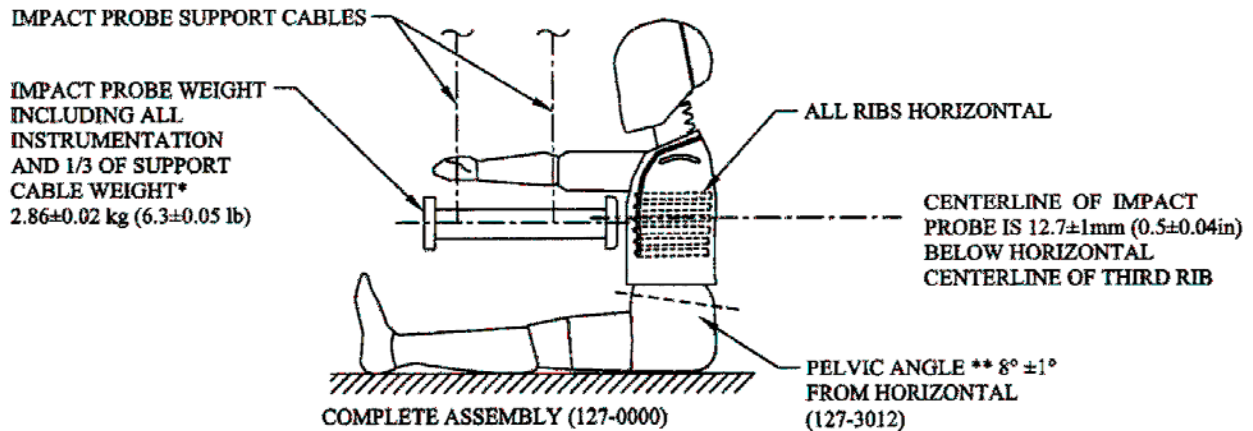

\* 1/3 CABLE WEIGHT NOT TO EXCEED 5% OF THE TOTAL IMPACT PROBE WEIGHT  
\*\* PELVIS LUMBAR JOINING SURFACE

**FIGURE 6. THORAX IMPACT TEST SET-UP**

### 10.6 TORSO ASSEMBLIES AND FLEXION TEST

The test objective is to determine the stiffness effects of the lumbar spine on resistance to articulation between upper torso assembly (drawing 167-2000) and lower torso assembly (drawing 167-3000).

#### 10.6.1 TEST SET-UP

The test set-up for the torso flexion test is shown in Figure 7.

#### 10.6.2 COMPONENTS FOR TORSO TEST (572.125)

The components for the torso test include the lumbar spine (per 572.125(a), drawing 127-3002), including cable (per 572.125(a), drawing 127-8095), mounting plate insert (per 572.125(a) drawing 910420-048), nylon shoulder bushing (per 572.125(a) drawing 9001373), nut (per 572.125(a) drawing 127-8210), spine box weighting plates (drawing 167-2020 Revision A), lumbar base weight (drawing 167-3010 Revision A), and abdominal insert (specified in 49 CFR 572.125(a)).

The dummy shall be assembled with or without legs below the femurs, for this test. (572.125(c)(2))

### 10.6.3 TORSO CALIBRATION REQUIREMENT (572.165(b))

- (1) When the upper torso assembly of a seated dummy is subjected to a force continuously applied at the head to neck pivot pin level through a rigidly attached adaptor bracket as shown in Figure 7, the lumbar spine-abdomen assembly must flex by an amount that permits the upper torso assembly to translate in angular motion until the machined surface of the instrument cavity at the back of the thoracic spine box is at  $45 \pm 0.5$  degrees relative to the transverse plane, at which time the force applied as shown in Figure 7 must be within  $88.6 \text{ N} \pm 25 \text{ N}$  ( $20.0 \text{ lbf} \pm 5.6 \text{ lbf}$ ), and
- (2) Upon removal of the force, the torso assembly must return to within 9 degrees of its initial position.

### 10.6.4 TORSO TEST PROCEDURE (572.165(c))

The upper and lower torso assemblies are tested as specified in 49 CFR 572.125(c), except that in paragraph (c)(5) of that section, the initial torso orientation angle may not exceed 32 degrees.

- (1) Soak the dummy at any temperature between  $18.9$  and  $25.6$  °C ( $66$  and  $78$  °F) and a relative humidity between 10 and 70 percent for at least four hours prior to a test.
- (2) Attach the dummy to the fixture in a seated posture as shown in Figure 7.
- (3) Secure the pelvis at the pelvis instrument cavity rear face by threading four  $1/4$  in cap screws into the available threaded attachment holes. Tighten the mountings so that the test material is rigidly affixed to the test fixture and the pelvic-lumbar joining surface is horizontal.
- (4) Flex the thorax forward three times between vertical and until the torso reference plane, as shown in Figure 7, reaches  $30 \pm 2$  degrees from vertical. Bring the torso to vertical orientation, remove all externally applied flexion forces, and wait 30 minutes before conducting the test. During the 30-minute waiting period, the dummy's upper torso shall be externally supported at or near its vertical orientation to prevent sagging.
- (5) Remove the external support and wait two minutes. Measure the initial orientation of the torso reference plane of the seated, unsupported dummy as shown in Figure 7. This initial torso orientation angle may not exceed 32 degrees. (572.165(c))
- (6) Attach the loading adapter bracket to the spine of the dummy, the pull cable, and the load cell as shown in Figure 7.

- (7) Apply a tension force in the midsagittal plane to the pull cable as shown in Figure 7 at any upper torso deflection rate between 0.5 and 1.5 degrees per second, until the torso reference plane is at  $45 \pm 0.5$  degrees of flexion relative to the vertical transverse plane as shown in Figure 7.
- (8) Continue to apply a force sufficient to maintain  $45 \pm 0.5$  degrees of flexion for 10 seconds, and record the highest applied force during the 10-second period.
- (9) Release all force as rapidly as possible, and measure the return angle at 3 minutes or any time thereafter after the release.

### TORSO FLEXION TEST SET-UP SPECIFICATIONS

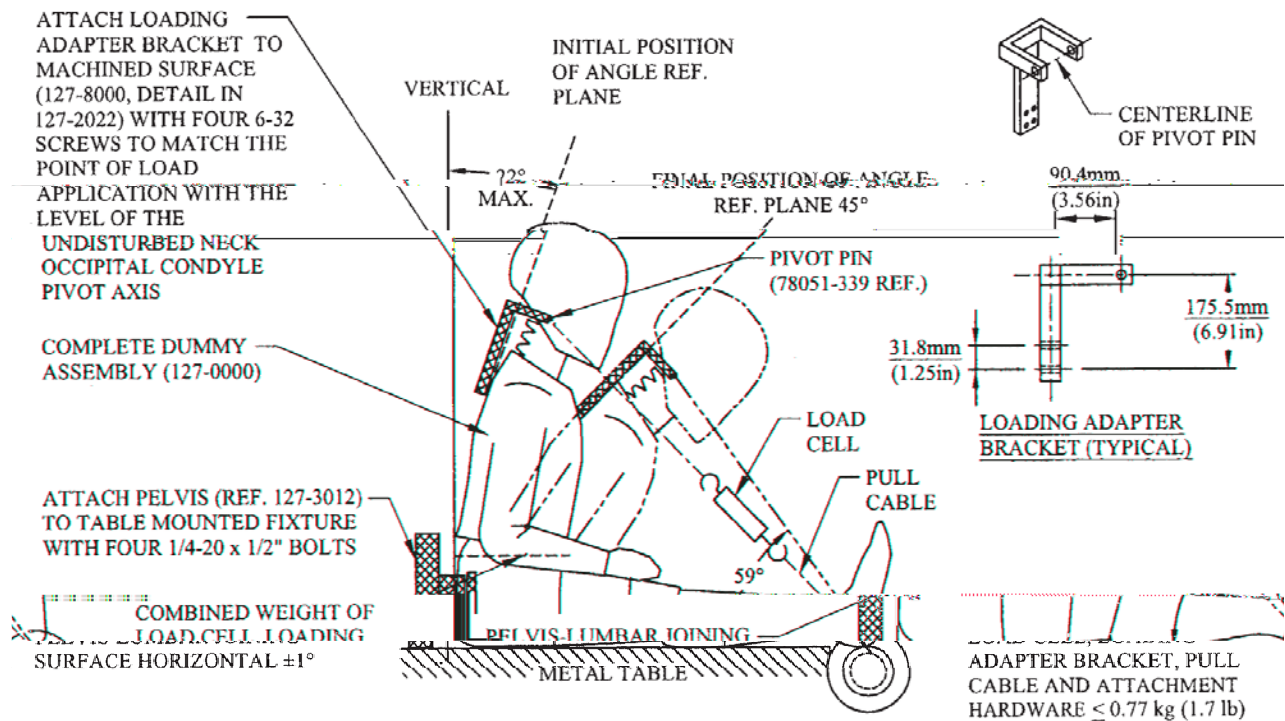

**FIGURE 7. TORSO FLEXION TEST**

## 10.7 KNEE (572.166)

### 10.7.1 TEST SET-UP

#### A. KNEE IMPACTOR PROBE (572.127(b))

- (1) The test probe for knee impacts shall be of rigid metallic construction, concentric in shape, and symmetric about its longitudinal axis.
- (2) It shall have a mass of  $0.82 \pm 0.02$  kg ( $1.8 \pm 0.05$  lb). 1/3 of the weight of the suspension cables and any attachments to the impact probe must be included in the calculation of mass, and such components may not exceed 5 percent of the total weight of the test probe.
- (3) It shall have a minimum mass moment of inertia of  $34 \text{ kg}\cdot\text{cm}^2$  ( $0.03 \text{ lb}\cdot\text{in}\cdot\text{sec}^2$ ) in yaw and pitch about the center of gravity.
- (4) The impacting end of the probe is perpendicular to and concentric with the longitudinal axis. It must have a flat, continuous, and non-deformable face with diameter of  $76.2 \pm 0.2$  mm ( $3.00 \pm 0.01$  in) and a maximum edge radius of 7.6-12.7 mm (0.3-0.5 in).
- (5) The impactor is a cylinder with a diameter of 76-77 mm (3.0-3.1 in) and it is at least 12.5 mm (0.5 in) long.
- (6) The probe's end opposite to the impact face must have provisions for mounting of an accelerometer with its sensitive axis collinear with the longitudinal axis of the probe.
- (7) The impact probe shall have a free air resonant frequency of not less than 1000 Hz in the direction of the longitudinal direction of the impactor.

## B. TEST FIXTURE

A rigid test fixture as shown in Figure 8 is required for this test.

### 10.7.2 COMPONENTS FOR KNEE TEST (572.126(b))

For the purposes of this test, the knee assembly consists of the machined knee components (drawing 127-4013), knee flesh (drawing 127-4011), lower leg (drawing 127-4014), the foot assembly (drawing 127-4030-1(left) and -2 (right)) and femur load transducer (drawing SA572-S10) or its structural replacement (drawing 127-4007).

### 10.7.3 KNEE CALIBRATION REQUIREMENT (572.126(b))

The peak resistance force as measured with the test probe mounted accelerometer must be not less than 2.0 kN (450 lbf) and not more than 3.0 kN (674 lbf).



#### 10.7.4 KNEE TEST PROCEDURE (572.126(c))

- (1) Soak the knee assembly at any temperature between 18.9 and 25.6 °C (66 and 78 °F) and a relative humidity from 10 to 70 percent for at least four hours prior to a test.
- (2) Mount the test material and secure it to the test fixture. No contact is permitted between any part of the foot or tibia and any exterior surface.
- (3) Align the test probe so that throughout its stroke and at contact with the knee it is within 2 degrees of horizontal and collinear with the longitudinal centerline of the femur.
- (4) Guide the pendulum so that there is no significant lateral vertical or rotational movement at time-zero.
- (5) The test probe velocity at the time of contact shall be  $2.1 \pm 0.03$  m/s ( $6.9 \pm 0.1$  ft/s).
- (6) No suspension hardware, suspension cables, or any other attachments to the probe, including the velocity vane, shall make contact with the dummy during testing.

#### KNEE IMPACT TEST SET-UP SPECIFICATIONS

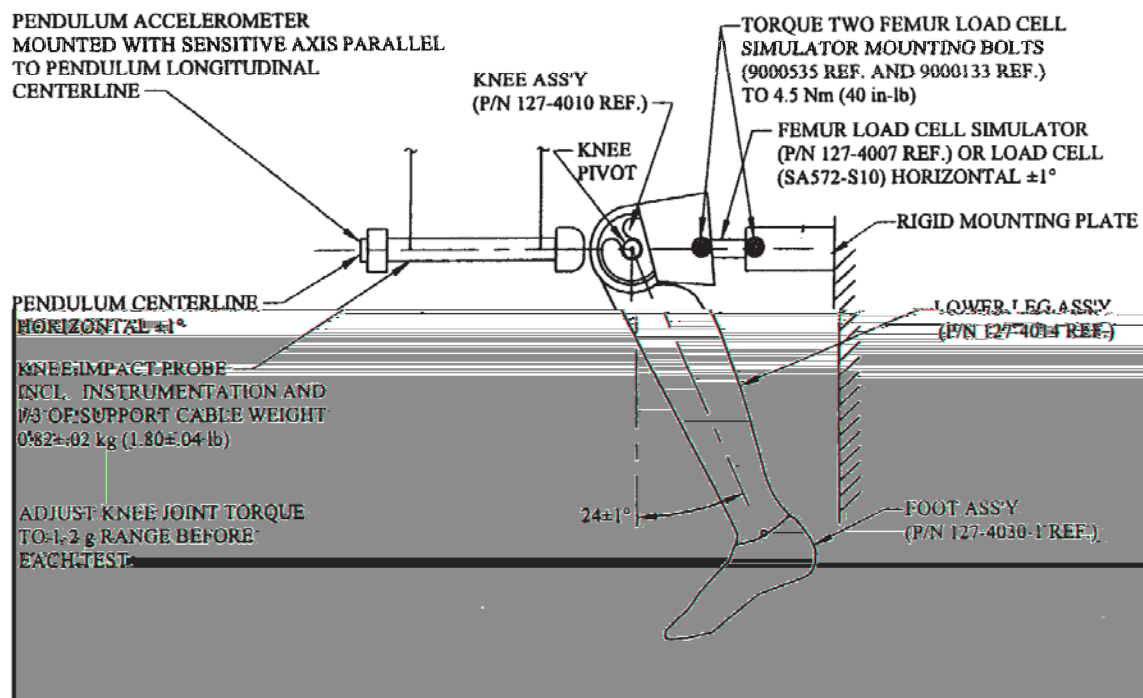

**FIGURE 8. KNEE IMPACT TEST**

## **11. CALIBRATION TEST EXECUTION**

When conducting calibration tests, complete the data sheets in section 14.

## **12. POSTTEST REQUIREMENTS**

The contractor shall verify all instrumentation operated properly to collect valid data and ensure the data sheets are complete and accurate.

## **13. REPORTS**

### **13.1 APPARENT NONCONFORMANCE**

During the posttest calibration verification, any indication of apparent nonconformance to the requirements of Regulation P572 shall be communicated by telephone to the COTR within 24 hours with written notification mailed within 48 hours (Saturdays and Sundays excluded). Written notification shall be submitted with a copy of the particular test data sheet(s) and preliminary data plot(s).

In the event of an apparent nonconformance, a posttest calibration check of some critically sensitive test equipment and instrumentation may be required for verification of accuracy. The necessity for the calibration shall be at the COTR's discretion and shall be performed without additional costs to the OVSC.

### **13.2 FINAL PERFORMANCE CALIBRATION REPORTS**

A report containing the pre-test calibration and posttest calibration verification data for each Part 572, Subpart N dummy used in a compliance test shall be submitted with the compliance final test report if requested by the COTR.

#### **13.2.1 REQUIREMENTS**

Performance calibration report Table of Contents shall include the following:

Section 1 — Purpose of Calibration Test

Section 2 — Calibration Data Summary

Section 3 — Test Data

Section 4 — Test Equipment List and Calibration Information

Section 5 — Photographs (if applicable)

The test data for each dummy will be presented in separate sections. Each section shall contain a title page, test results summary, and the test data. The title page shall include the dummy's serial number and the manufacturer's name. It will also indicate whether the calibration data is pre or posttest. The test results sheets will provide a summary of each test and describe any damage, failures and/or corrective action taken. The test data shall include the pass/fail data sheets, the time histories for each data channel used to determine the pass or fail status, and instrumentation calibration data sheets.

### 13.2.3 FIRST PAGE

#### FRONT COVER

The information required on the cover is as follows:

- A. Final Report Title And Subtitle such as

DUMMY PERFORMANCE CALIBRATION  
IN SUPPORT OF  
CHILD RESTRAINT SYSTEM TESTING  
DYNAMIC TESTS  
FMVSS No. 213

- B. Contractor's Name and Address such as



ABC TESTING LABORATORIES, INC.  
405 Main Street  
Detroit, Michigan 48070

**NOTE:** DOT SYMBOL WILL BE PLACED BETWEEN ITEMS B AND C

- C. Date of Final Performance Calibration Report completion
- D. The sponsoring agency's name and address as follows

U. S. DEPARTMENT OF TRANSPORTATION  
National Highway Traffic Safety Administration  
Enforcement  
Office of Vehicle Safety Compliance  
Mail Code: NVS-220, W43-481  
1200 New Jersey Avenue, SE  
Washington, DC 20590

**14. DATA SHEETS**

DATA SHEET 1  
DUMMY DAMAGE CHECKLIST

Dummy Serial Number \_\_\_\_\_ Test Date \_\_\_\_\_

Technician \_\_\_\_\_

This check sheet is completed as part of the post test calibration verification.

Perform general cleaning.

Dummy Item	Inspect for	Comments	Damaged	OK
Outer skin	Gashes, rips, cracks			
Head	Ballast secure			
	General appearance			
Neck	Broken or cracked rubber			
	Upper neck bracket firmly attached to the lower neck bracket			
	Looseness at the condyle joint			
	Nodding blocks cracked or out of position			
Spine	Broken or cracks in rubber.			
Ribs	Broken or bent ribs			
	Broken or bent rib supports			
	Damping material separated or cracked			
	Rubber bumpers in place			
Chest Displacement Assembly	Bent shaft			
	Slider arm riding in track			
Abdomen	Proper positioning			
Transducer leads	Torn cables			

Dummy Item	Inspect for	Comments	Damaged	OK
Accelerometer Mountings	Head mounting secure			
	Chest mounting secure			
Knees	Skin condition			
	Insert (do not remove)			
	Casting			
Limbs	Normal movement and adjustment			
Knee Sliders	Wires intact			
	Rubber returned to "at rest" position			
Pelvis	Broken			
Other				

If upon visual examination, damage is apparent in any of these areas, the appropriate engineer or engineering technician is to be consulted for a decision on repair or replacement of parts.

Repair or Replacement approved by:

\_\_\_\_\_

Signature

\_\_\_\_\_

Date

Describe the repair or replacement of parts:

Checked by

\_\_\_\_\_

Signature

\_\_\_\_\_

Date

DATA SHEET 2  
EXTERNAL MEASUREMENTS

Dummy Serial Number \_\_\_\_\_ Test Date \_\_\_\_\_

Technician \_\_\_\_\_

Pretest calibration  
 Posttest calibration verification

- 1. Remove the dummy's chest jacket and the abdominal insert.
- 2. Seat the dummy on a flat, rigid, smooth, clean, dry, horizontal surface as shown. The seating surface is at least 215.9 mm (8.5 in) wide and 330.2 mm (13 in) in depth with a vertical section at least 215.9 mm (8.5 in) wide and 635 mm (25 in) high attached to the rear of the seating fixture. The dummy's midsagittal plane is vertical and centered on the test surface.
- 3. Remove the four 1/4-20 x 7/8 SHCS that attach the lumbar spine bracket to the pelvis. Torque the spine cable to  $0.22 \pm .02$  Nm ( $2.0 \pm 0.2$  in-lb).

**NOTE:** At this point the thorax is to be inspected for damage. The thorax displacement transducer may be removed for calibration if required (pretest calibration only). Extreme caution to be used so as not to damage the instrumentation cables.

- 4. Reassemble the lumbar spine bracket to the pelvis.
- 5. Secure the dummy to the test fixture so that the rear surfaces of the upper thorax and the buttock are tangent to the rear vertical surface of the fixture (or as near tangent as possible). The dummy's midsagittal plane should be vertical.
- 6. Position the dummy's H-point so it is  $68.6 \pm 5.1$  mm ( $2.7 \pm 0.2$  in) above the horizontal seating surface and  $94.0 \pm 5.1$  mm ( $3.7 \pm 0.2$  in) forward of the rear vertical surface of the fixture. The H-point is located 34.5 mm (1.36 in) forward and 48.7 mm (1.92 in) downward from the center pelvic angle reference hole.
- 7. Extend the dummy's neck so that the plane perpendicular to the skull to skullcap interface is level both fore-and-aft and side-to-side, within 0.5 degrees. (The vertical mating surface between the skull and skull cap will be vertical.) The rear surface of the skullcap should be  $20.3 \pm 2.5$  mm ( $0.8 \pm 0.1$  in) from the vertical surface of the test fixture. A strap or bungee cord may be placed around the forehead of the dummy to stabilize the head in this position.
- 8. Position the upper and lower legs parallel to the midsagittal plane so the knee and ankle pivots centerlines are parallel, forming a  $90^\circ$  angle between the tibia and femur.
- 9. Position the feet parallel to the dummy's midsagittal plane with the bottoms horizontal and parallel to the seating surface.
- 10. Position the upper arms downward vertically so the centerlines of the shoulder yoke and elbow pivots are parallel.

- \_\_ 11. Position the lower arms horizontally so the centerline of the elbow and wrist pivot are parallel.
- \_\_ 12. Record the dimensions listed in following table, except for dimension Y and Z (reference Figure 9).
- \_\_ 13. Install the abdominal insert and chest jacket. Reposition the dummy on the test fixture. The head need not be level as previously specified.
- \_\_ 14. Mark the locations AA, and BB, and record the dimensions Y, Z, as specified in following table and Figure 9.

\_\_\_\_\_  
Signature

\_\_\_\_\_  
Date



**TABLE 4. EXTERNAL DIMENSIONS**

HYBRID III, PART 572, SUBPART S EXTERNAL DIMENSIONS				
DIMENSION	DESCRIPTION	DETAILS	ASSEMBLY DIMENSION (mm)	ACTUAL MEASUREMENT
A	TOTAL SITTING HEIGHT	Seat surface to highest point on top of the head.	640.6 – 666.0	
B	SHOULDER PIVOT HEIGHT	Centerline of shoulder pivot bolt to the seat surface.	366.3 – 381.5	
C	H-POINT HEIGHT	Reference	63.5 - 73.7	
D	H-POINT LOCATION FROM BACKLINE	Reference	88.9 - 99.1	
E	SHOULDER PIVOT FROM BACKLINE	Center of the shoulder clevis to the rear vertical surface of the fixture.	53.3 - 63.5	
F	THIGH CLEARANCE	Measured at the highest point on the upper femur segment.	88.9 - 104.1	
G	BACK OF ELBOW TO WRIST PIVOT	back of the elbow flesh to the wrist pivot in line with the elbow and wrist pivots	182.9 - 198.1	
H	HEAD BACK TO BACKLINE	Back of Skull cap skin to seat rear vertical surface (Reference)	17.8 - 22.8	
I	SHOULDER TO- ELBOW LENGTH	Measure from the highest point on top of the broad upper surface of clavicle link below the collar of the lowest part of the flesh of the elbow in line with the elbow pivot bolt.	215.9 - 231.1	
J	ELBOW REST HEIGHT	Measure from the flesh below the elbow pivot bolt to the seat surface.	175.8 – 196.1	
K	BUTTOCK TO KNEE LENGTH	The forward most part of the knee flesh to the rear vertical surface of the fixture.	370.8 - 391.2	
L	POPLITEAL HEIGHT	Seat surface to the horizontal plane at the bottom of the feet.	269.2 - 289.6	
M	KNEE PIVOT HEIGHT	Centerline of knee pivot bolt to the horizontal plane of the bottom of the feet.	307.4 - 322.6	
HYBRID III, SUBPART S EXTERNAL DIMENSIONS, continued				

DIMENSION	DESCRIPTION	DETAILS	ASSEMBLY DIMENSION (mm)	ACTUAL MEASUREMENT
N	BUTTOCK POPLITEAL LENGTH	The rearmost surface of the lower leg to the same point on the rear surface of the buttocks used for dim. "K".	320.0 - 340.4	
O	CHEST DEPTH WITHOUT JACKET	Measured $330.2 \pm 5.1$ mm above seat surface	129.6 - 144.8	
P	FOOT LENGTH	Tip of toe to rear of heal	170.2 - 185.4	
Q	STATURE	(THEORETICAL) ( $Q = A - C - D + R + M$ )	1099.9 - 1181.1	N/A
R	BUTTOCK TO KNEE PIVOT LENGTH	The rear surface of the buttocks to the knee pivot bolt	342.9 - 363.3	
S	HEAD BREADTH	The widest part of the head	137.1 - 147.3	
T	HEAD DEPTH	Back of the head to the forehead	167.6 - 177.8	
U	HIP BREADTH	The widest part of the hips	208.3 - 223.5	
V	SHOULDER BREADTH	Outside shoulder edges, in line with the shoulder pivot bolts	259.1 - 274.3	
W	FOOT BREADTH	The widest part of the foot	62.3 - 77.5	
X	HEAD CIRCUMFERENCE	Measured at the point as in dim. "T"	510.5 - 530.9	
Y	CHEST CIRCUMFERENCE (WITH CHEST JACKET)	Measured $3330.2 \pm 5.1$ mm above seat surface	596.9 - 622.3	
Z	WAIST CIRCUMFERENCE (with chest jacket and abdominal insert)	Measured $158.8 \pm 5.1$ mm above seat surface	558.8 - 584.2	
AA	REFERENCE LOCATION FOR MEASUREMENT OF CHEST CIRCUMFERENCE	Reference	343.4 - 353.6	
BB	REFERENCE LOCATION FOR MEASUREMENT OF WAIST CIRCUMFERENCE	Reference	153.7 - 163.9	

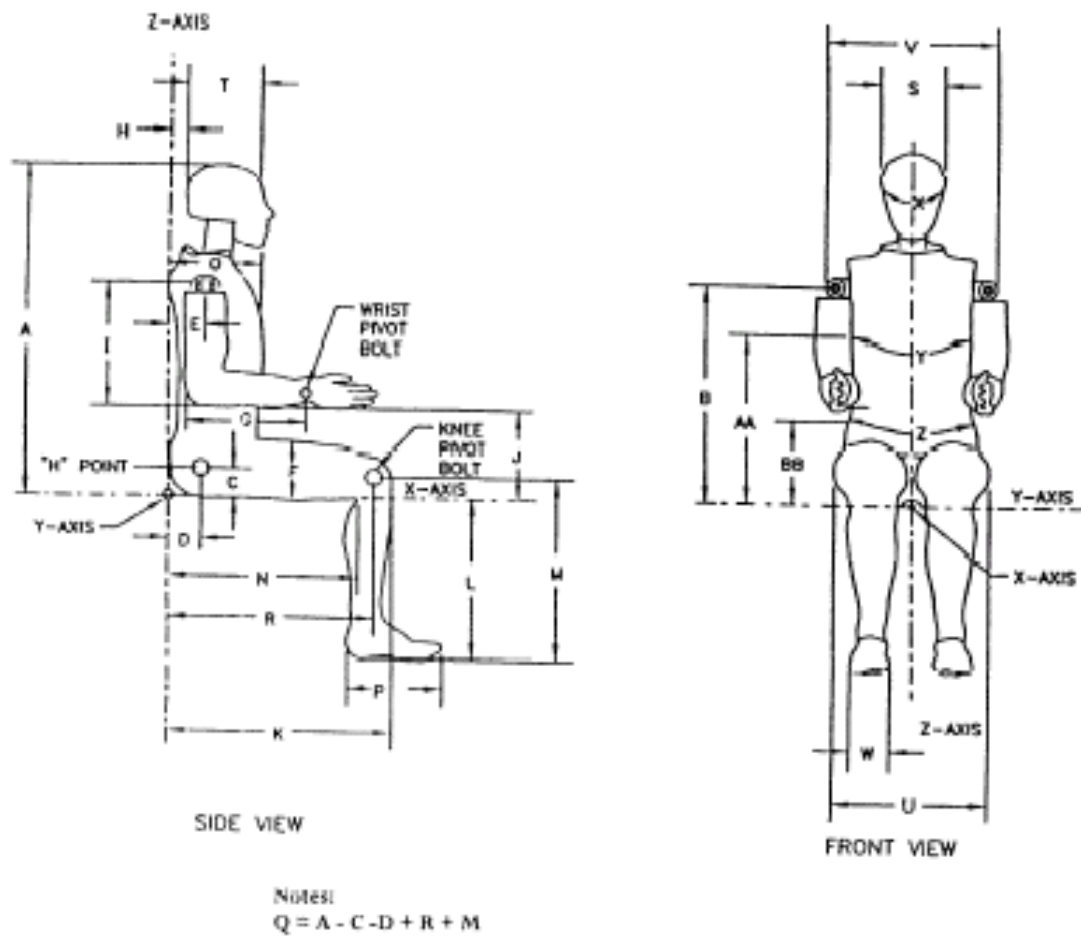
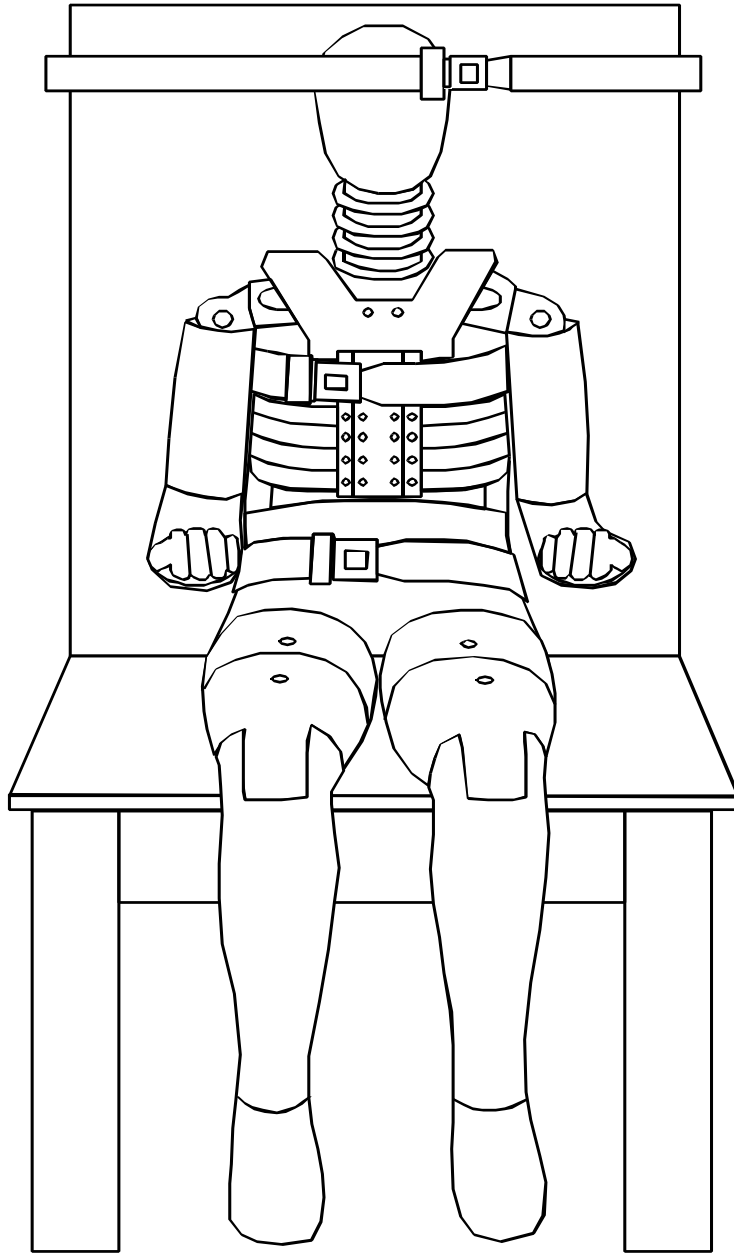
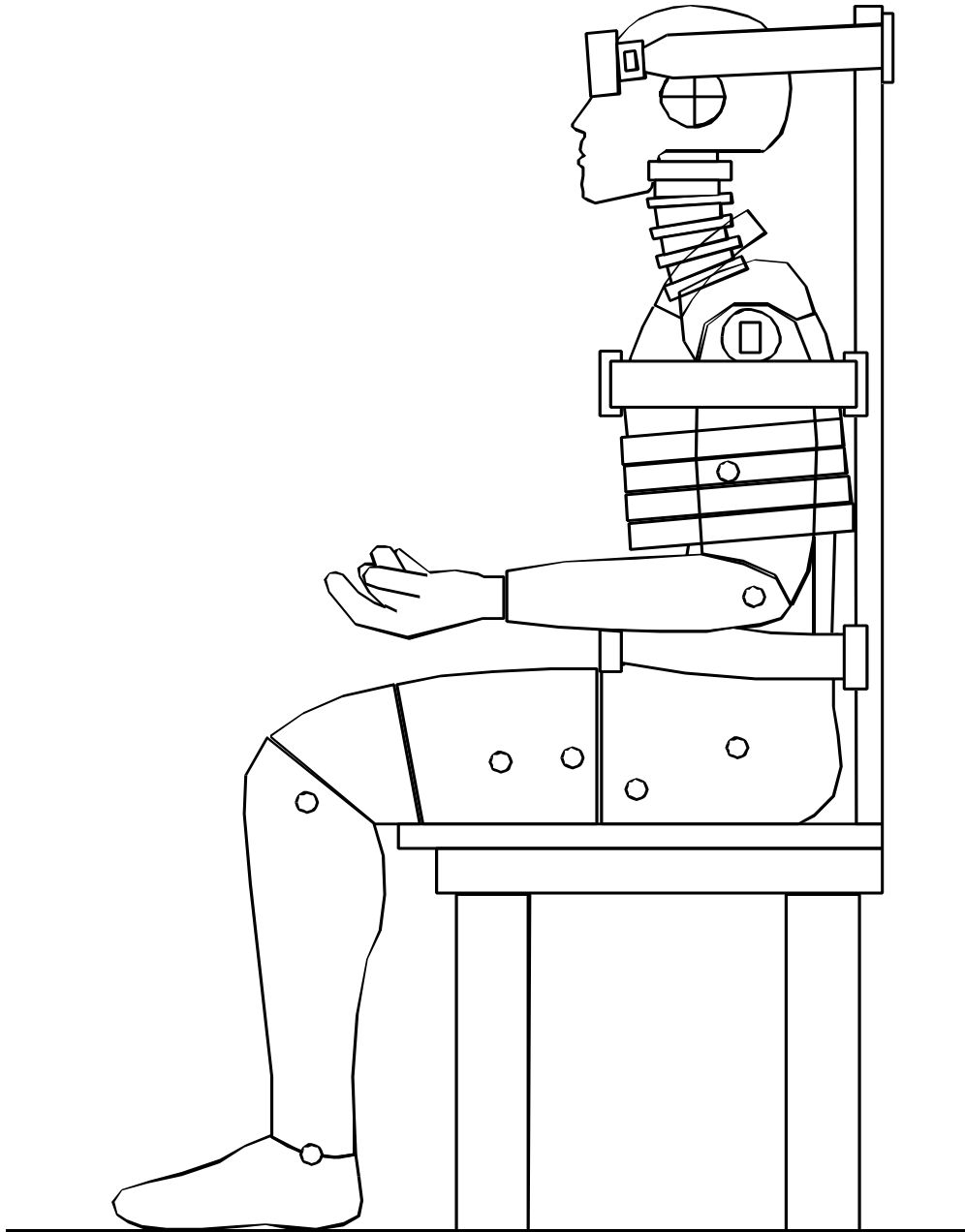

FIGURE 9. EXTERNAL DIMENSIONS OF 6YO HIII CHILD TEST DUMMY



**FIGURE 10. EXTERNAL DIMENSIONS TEST SET UP**



**FIGURE 11. EXTERNAL DIMENSIONS TEST SETUP – SIDE VIEW**

DATA SHEET 3  
HEAD DROP TEST (572.162)

Dummy Serial Number \_\_\_\_\_ Test Date \_\_\_\_\_

Technician \_\_\_\_\_

- Pretest calibration
- Post test calibration verification

Test attempt no. \_\_\_\_\_ (when successive head drops are necessary)

- 1. It has been at least 2 hours since the last head drop. (572.122(c)(5))  
 N/A, ONLY one head drop performed
- 2. The head assembly consists of the complete head (127-1000), a six-axis neck transducer (SA572-S11) or its structural replacement (78051-383X), a head to neck pivot pin (78051-339), and three (3) accelerometers (SA572-S4). (572.122(a))
- 3. The head assembly has soaked at a temperature between 18.9°C (66°F) and 25.6°C (78°F) and at a relative humidity from 10% to 70% for at least four (4) hours prior to this test. (572.122(c)(1))  
Record the maximum temperature \_\_\_\_\_  
Record the minimum temperature \_\_\_\_\_  
Record the maximum humidity \_\_\_\_\_  
Record the minimum humidity \_\_\_\_\_
- 4. Torque the skull cap screws (10-32 x 1/2 SHCS) to 7.68 Nm.
- 5. Accelerometers and their respective mounts are smooth and clean.
- 6. The head accelerometer mounting plate screws (10-24 x 5/8 SHCS) are torqued to 6.78 Nm.
- 7. The data acquisition system, including transducers, conforms to the requirements of SAE Recommended Practice J211/1 MAR95. (572.127(k))
- 8. Visually inspect the head skin for cracks, cuts, abrasions, etc. Repair or replace the head skin if the damaged area is more than superficial. Note: If the damage resulted from the test, the damaged area is to be documented with photography and the post test calibration verification testing completed before any replacement or repairs are made.  
Record findings and actions: \_\_\_\_\_  
\_\_\_\_\_  
\_\_\_\_\_  
\_\_\_\_\_
- 9. Clean the impact surface of the skin and the impact surface of the fixture with isopropyl alcohol, trichloroethane or equivalent prior to the test. (572.122(c)(2))

\_\_10. Suspend and orient the head assembly as shown in Figure 2. The lowest point on the forehead is  $376.0 \pm 1.0$  mm ( $14.8 \pm 0.04$  inch) from the impact surface. (572.122(c)(3))  
 Record the actual distance \_\_\_\_\_

**NOTE:** The masses of the suspension device and the accelerometer cables are to be kept as lightweight as possible to minimize their effect on the test results.

\_\_11. The 1.57 mm (0.062 inch) diameter holes located on either side of the dummy's head are equidistant within 2 mm from the impact surface. A typical test setup is shown in Figure 2. (572.122(c)(3))  
 Record the right side distance \_\_\_\_\_  
 Record the left side distance \_\_\_\_\_

\_\_12. The impact surface is clean and dry and has a micro finish in the range of  $203.2 \times 10^{-6}$  mm (8 micro inches) to  $2032.0 \times 10^{-6}$  mm (80 micro inches) (RMS). (572.122(c)(4))  
 Record actual micro finish \_\_\_\_\_

\_\_13. Drop the head assembly from a height of  $376.0 \pm 1.0$  mm ( $14.8 \pm 0.04$  inches) by a means that ensures a smooth, instant release onto the impact surface. (572.122(b) & 572.122(c)(4))

\_\_14. Complete the following table using channel class 1000 data. (572.122(b)):

Parameter	Specification	Result
Peak resultant acceleration	$245 \text{ g} \leq x \leq 300 \text{ g}$	
Resultant versus time history curve	Unimodal	
Oscillations after the main pulse	Less than 10% of the peak resultant acceleration	
Lateral acceleration	y-axis acceleration $\leq 15 \text{ g}$	

\_\_15. Plots of the x, y, z, and resultant acceleration data follow this sheet.

\_\_\_\_\_  
 Signature

\_\_\_\_\_  
 Date

DATA SHEET 4  
NECK FLEXION TEST (572.163)

Dummy Serial Number \_\_\_\_\_ Test Date \_\_\_\_\_

Technician \_\_\_\_\_

Pretest calibration  
 Posttest calibration verification

Test attempt no. \_\_\_\_\_ (when successive flexion tests are necessary)

- 1. It has been at least 30 minutes since the last neck test. (572.127(o))  
 N/A, ONLY one flexion test performed
- 2. The components required for the neck tests include the head assembly (127-1000), neck (127-1015), pivot pin (78051-339), bib simulator (TE127-1025), neck bracket assembly (127-8221), six axis neck transducer (SA572-S11), neck mounting adaptor (TE-2208-001) and three accelerometers (SA572-S4) installed in the head assembly as specified in S572.122. Data from the accelerometers are not required. (572.123(b))
- 3. The assembly soaked at a temperature between 20.6°C (69°F) and 22.2°C (72°F) and at a relative humidity from 10% to 70% for a period of at least four (4) hours prior to a test. (572.123(c)(1))  
Record the maximum temperature \_\_\_\_\_  
Record the minimum temperature \_\_\_\_\_  
Record the maximum humidity \_\_\_\_\_  
Record the minimum humidity \_\_\_\_\_
- 4. Visually inspect neck assembly for cracks, cuts and separation of the rubber from the metal segments. Note: If the damage resulted from the vehicle crash test in which the dummy was an occupant, the damaged area is to be documented with photography and the posttest calibration verification testing completed before any replacement or repairs are made.  
Record findings and actions: \_\_\_\_\_  
\_\_\_\_\_  
\_\_\_\_\_  
\_\_\_\_\_
- 5. Inspect the nodding blocks (127-1020, 127-1021) for splits or deformation. Inspect the Neck Cable (127-1016) for deformation. Inspect the mounting plate insert ( 910420-048) and the nylon shoulder bushing (9001373) and replace if they are torn or worn. When replacement is necessary, ONLY replace during pre-test calibration.  
Record findings and actions: \_\_\_\_\_  
\_\_\_\_\_  
\_\_\_\_\_



- \_\_6. Torque the jam nut (9000341) on the neck cable (127-1016) to  $0.23 \pm 0.02$  Nm ( $2.0 \pm 0.2$  in-lb). (572.123(c)(2))
- \_\_7. The data acquisition system, including transducers, conforms to the requirements of SAE Recommended Practice J211/1 MAR95. (572.127(k))
- \_\_8. The test fixture pendulum conforms to the specifications in Figure 5. (572.123(c)(3))
- \_\_9. The head-neck assembly is mounted on the pendulum so the midsagittal plane of the head is vertical and coincides with the plane of motion of the pendulum longitudinal centerline as shown in Figure 3 for the flexion test. (572.123(c)(3))
- \_\_10. With the pendulum resting against the honeycomb material, the neck bracket was adjusted until the longitudinal centerline of the pendulum was perpendicular  $\pm 1$  degree to plane "D" on the dummy's head.
- \_\_11. Release the pendulum and allow it to fall freely from a height to achieve an impact speed of 4.83 m/s to 5.07 m/s as measured at the center of the pendulum accelerometer. (572.123(c)(4))
- \_\_12. Complete the following table:

Neck Flexion Test Results (572.123(b)(1) & (572.123(c)(4)(i & ii))

Parameter	Specification	Result
Pendulum impact speed	$4.83 \text{ m/s} \leq \text{speed} \leq 5.07 \text{ m/s}$	
Pendulum $\Delta V$ with respect to impact speed	@ 10ms	$1.2 \text{ m/s} \leq \Delta V \leq 1.6 \text{ m/s}$
	@ 20 ms	$2.4 \text{ m/s} \leq \Delta V \leq 3.4 \text{ m/s}$
	@30ms	$3.8 \text{ m/s} \leq \Delta V \leq 5.0 \text{ m/s}$
Plane D Rotation	Peak moment* $27 \text{ Nm} \leq \text{moment} \leq 33 \text{ Nm}$ during the following rotation range $74^\circ \leq \text{angle} \leq 92^\circ$	____ Nm @ ____ degrees
Positive Moment Decay** (Flexion)	Time to decay to 5 Nm $103 \text{ ms} \leq \text{time} \leq 123 \text{ ms}$	

\*Moment about the occipital condyle =  $M_y - (0.01778 \text{ m} \times F_x)$  (572.123(b)(1)(iii))

$M_y$  = Moment in Nm measured by the transducer

$F_x$  = Force in N measured by the transducer

\*\*Time zero is defined as the time of initial contact between the pendulum striker plate and the honeycomb material. (572.123(b)(3))

- \_\_13. Plots of acceleration, velocity, y-axis moment, and x-axis force and y-axis moment about the occipital condyle follow this sheet.

\_\_\_\_\_  
Signature

\_\_\_\_\_  
Date

DATA SHEET 5  
NECK EXTENSION TEST (572.163)

Dummy Serial Number \_\_\_\_\_ Test Date \_\_\_\_\_

Technician \_\_\_\_\_

- Pretest calibration
- Posttest calibration verification

Test attempt no. \_\_\_\_\_ (when successive extension tests are necessary)

- 1. It has been at least 30 minutes since the last neck test. (572.127(o))  
 N/A, ONLY one extension test performed
- 2. The components required for the neck tests include the head assembly (127-1000), neck (127-1015), pivot pin (78051-339), bib simulator (TE127-1025), neck bracket assembly (127-8221), six axis neck transducer (SA572-S11), neck mounting adaptor (TE-2208-001) and three accelerometers (SA572-S4) installed in the head assembly as specified in S572.122. Data from the accelerometers are not required. (572.123(b))
- 3. The assembly soaked at a temperature between 20.6°C (69°F) and 22.2°C (72°F) and at a relative humidity from 10% to 70% for a period of at least four (4) hours prior to a test. (572.123(c)(1))  
Record the maximum temperature \_\_\_\_\_  
Record the minimum temperature \_\_\_\_\_  
Record the maximum humidity \_\_\_\_\_  
Record the minimum humidity \_\_\_\_\_
- 4. Visually inspect neck assembly for cracks, cuts and separation of the rubber from the metal segments. Note: If the damage resulted from the vehicle crash test in which the dummy was an occupant, the damaged area is to be documented with photography and the posttest calibration verification testing completed before any replacement or repairs are made.  
Record findings and actions: \_\_\_\_\_  
\_\_\_\_\_  
\_\_\_\_\_  
\_\_\_\_\_
- 5. Inspect the nodding blocks (127-1020, 127-1021) for splits or deformation. Inspect the neck cable (127-1016) for deformation. Inspect the mounting plate insert ( 910420-048) and the nylon shoulder bushing (9001373) and replace if they are torn or worn. When replacement is necessary, ONLY replace during pre-test calibration.  
Record findings and actions: \_\_\_\_\_  
\_\_\_\_\_  
\_\_\_\_\_

- \_\_6. Torque the jam nut (9000341) on the neck cable (127-1016) to  $0.23 \pm 0.02$  Nm ( $2.0 \pm 0.2$  in-lb). (572.123(c)(2))
- \_\_7. The data acquisition system, including transducers, conforms to the requirements of SAE Recommended Practice J211/1 MAR95. (572.127(k))
- \_\_8. The test fixture pendulum conforms to the specifications in Figure 5. (572.123(c)(3))
- \_\_9. The head-neck assembly is mounted on the pendulum so the midsagittal plane of the head is vertical and coincides with the plane of motion of the pendulum longitudinal centerline as shown in Figure 4 for the extension test. (572.123(c)(3))
- \_\_10. With the pendulum resting against the honeycomb material, the neck bracket was adjusted until the longitudinal centerline of the pendulum was perpendicular  $\pm 1^\circ$  to plane "D" on the dummy's head.
- \_\_11. Release the pendulum and allow it to fall freely from a height to achieve an impact speed of 4.18 m/s to 4.42 m/s as measured at the center of the pendulum accelerometer. (572.123(c)(4))
- \_\_12. Complete the following table:

Neck Extension Test Results (572.123(b)(2) & (572.123(c)(4)(i & ii))

Parameter	Specification	Result
Pendulum impact speed	$4.18 \text{ m/s} \leq \text{speed} \leq 4.42 \text{ m/s}$	
Pendulum $\Delta V$ with respect to impact speed	@ 10ms	$1.0 \text{ m/s} \leq \Delta V \leq 1.4 \text{ m/s}$
	@ 20 ms	$2.2 \text{ m/s} \leq \Delta V \leq 3.0 \text{ m/s}$
	@30ms	$3.2 \text{ m/s} \leq \Delta V \leq 4.2 \text{ m/s}$
Plane D Rotation	Peak moment* $-24 \text{ Nm} \leq \text{moment} \leq -19 \text{ Nm}$ during the following rotation range $85^\circ \leq \text{angle} \leq 103^\circ$	____ Nm @ ____ degrees
Negative Moment Decay** (Extension)	Time to decay to -5 Nm $123 \text{ ms} \leq \text{time} \leq 147 \text{ ms}$	

\*Moment about the occipital condyle =  $M_y - (0.01778 \text{ m} \times F_x)$  (572.123(b)(2)(iii))

$M_y$  = Moment in Nm measured by the transducer

$F_x$  = Force, in N measured by the transducer

\*\*Time zero is defined as the time of initial contact between the pendulum striker plate and the honeycomb material. (572.123(b)(3))

- \_\_13. Plots of acceleration, velocity, y-axis moment, and x-axis force and y-axis moment about the occipital condyle follow this sheet.

\_\_\_\_\_  
Signature

\_\_\_\_\_  
Date

DATA SHEET 6  
THORAX IMPACT TEST (572.164)

Dummy Serial Number \_\_\_\_\_ Test Date \_\_\_\_\_

Technician \_\_\_\_\_

Pretest calibration  
 Posttest calibration verification

Test attempt no. \_\_\_\_\_ (when successive thorax impact tests are necessary)

- 1. It has been at least 30 minutes since the last thorax impact test. (572.127(o))  
 N/A, ONLY one thorax impact test performed
- 2. The test fixture conforms to the specifications in Figure 6.
- 3. The complete assembled dummy (167-0000) is used (572.164(b)).
- 4. The dummy assembly soaked at a temperature between 20.6°C (69°F) and 22.2°C (72°F) and at a relative humidity from 10% to 70% for at least four (4) hours prior to this test. (572.124(c)(1))  
Record the maximum temperature \_\_\_\_\_  
Record the minimum temperature \_\_\_\_\_  
Record the maximum humidity \_\_\_\_\_  
Record the minimum humidity \_\_\_\_\_
- 5. Remove the chest skin and visually inspect the thorax assembly for cracks, cuts, abrasions, etc. Particular attention should be given to the rib damping material, chest displacement transducer assembly and the rear rib supports. Inspect for rib deformation using the chest depth gage. If any damage is noted repair and/or replace the damaged components unless the damage resulted from the vehicle crash test in which the dummy was an occupant in which case the damage must be documented and posttest calibration verification testing completed before any repairs or replacements are made.  
 - No damage  
 - Damage from crash test, no repairs or replacement because this is a posttest calibration verification. Record damage  
\_\_\_\_\_  
\_\_\_\_\_  
 - The following repairs or replacement was performed.  
\_\_\_\_\_  
\_\_\_\_\_
- 6. The dummy is dressed in a size 4 pair of long pants having a weight of less than 0.090 kg (0.2 lb) with the legs cut off sufficiently above the knee to allow the knee target to be visible. (572.124(c)(2))
- 7. Seat the dummy, (chest skin still removed) without back support on the test fixture surface as shown in Figure 6. The surface must be long enough to support the pelvis and outstretched legs. (572.124(c)(2))

- \_\_\_8. Level the ribs both longitudinally and laterally  $\pm 0.5^\circ$  and adjust the pelvis angle to  $8^\circ \pm 1^\circ$ . The angle may be measured at the pelvis lumbar joining surface.
- \_\_\_9. The midsagittal plane of the dummy is vertical within  $\pm 1^\circ$ . (572.124(c)(3))
- \_\_\_10. The longitudinal centerline of the test probe is centered within  $\pm 2.5$  mm of the midsagittal plane of the dummy and is  $12.7 \text{ mm} \pm 1 \text{ mm}$  below the horizontal peripheral centerline of the No. 3 rib and is within  $0.5^\circ$  of a horizontal line in the dummy's midsagittal plane. (572.124(c)(3))
- \_\_\_11. Record locations such as the rear surfaces of the thoracic spine and the lower neck bracket reference with respect to locations such as the rear surfaces of the thoracic spine and the lower neck bracket. These reference measurements are necessary to ensure the dummy is in the same position after the chest skin is installed. The reference locations must be accessible after installation of the chest skin. It may be necessary to leave the chest skin zipper unfastened until the references are checked and fasten it just prior to the test.
- \_\_\_12. Install the chest skin and reposition the dummy as described in the preceding paragraph using the reference measurements recorded.
- \_\_\_13. The dummy is dressed in a tight-fitting size 5 short sleeve shirt. (572.124(c)(2))
- \_\_\_14. Place the arm assemblies horizontal  $\pm 2^\circ$  and parallel to the midsagittal plane. The arms are held in place by tightening the adjustment nut which holds the arm yoke to the clavicle assembly.
- \_\_\_15. The data acquisition system, including transducers, must conform to the requirements of SAE Recommended Practice J2111/1 MAR95 (572.127(k))
- \_\_\_16. Impact the anterior surface of the thorax with the test probe so the longitudinal centerline of the probe is within  $2^\circ$  of a horizontal line in the dummy's midsagittal plane at the moment of impact. (572.164(c)(4)) The velocity of the test probe at the time of impact is  $6.71 \text{ m/s} \pm 0.12 \text{ m/s}$ . (572.164(b)) The probe is guided so there is no significant lateral, vertical or rotational movement during the impact. (572.124(c)(5)) Neither the suspension hardware, suspension cables, nor other attachments to the probe, including the velocity vane, make contact with the dummy. (572.124(c)(6))

\_\_17. Complete the following table:

Thorax Impact Results (572.164(b) and 572.164(b)(1)&(2))

Parameter*	Specification	Result
Test Probe Speed	6.59 m/s ≤ speed ≤ 6.83 m/s	
Chest Compression	38.0 mm ≤ compression ≤ 46.0 mm	
Peak force** between 38.0 and 46.0 mm chest compression	1205N ≤ peak force ≤ 1435N	
Peak force** between 12.5 and 38.0 mm chest compression	Max. force ≤ 1500N	
Internal Hysteresis***	65% ≤ hysteresis ≤ 85%	

\*Time zero is defined as the time of initial contact between the test probe and the chest skin.

\*\*Force = impactor mass x acceleration

\*\*\*Area under loading curve minus the area under the unloading curve divided by the area under the loading curve. (Figure 12)

\_\_18. Plots of chest compression, acceleration, force, force versus deflection follow this sheet.

Signature \_\_\_\_\_

Date \_\_\_\_\_

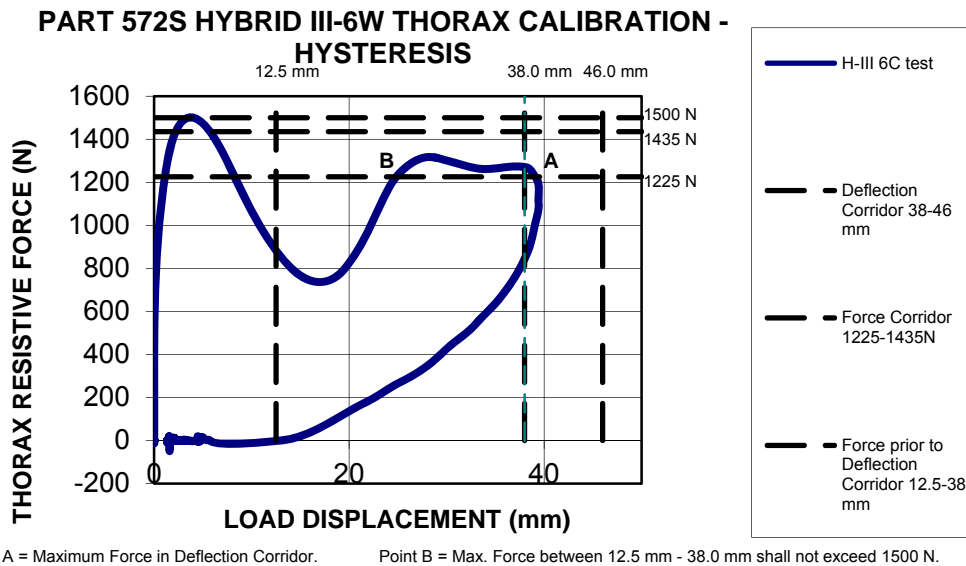

**FIGURE 12. PART 572S HYBRID III-6W THORAX CALIBRATION – HYSTERESIS**

DATA SHEET 7  
TORSO FLEXION TEST (572.165)

Dummy Serial Number \_\_\_\_\_ Test Date \_\_\_\_\_

Technician \_\_\_\_\_

Pretest calibration  
 Posttest calibration verification

Test attempt no. \_\_\_\_\_ (when successive torso flexion tests are necessary)

- 1. It has been at least 30 minutes since the last torso flexion test. (572.127(o))  
 N/A, ONLY one torso flexion test performed
- 2. The test fixture conforms to the specifications in Figure 7.
- 3. The complete assembled dummy (167-0000) is used (572.125(c)(2)).  
 with legs below the femurs.  
 without legs below the femurs.
- 4. The dummy assembly soaked at a temperature between 18.9°C (66°F) and 25.6°C (78°F) and at a relative humidity from 10% to 70% for a period of at least four (4) hours prior to this test. (572.125(c)(1))  
Record the maximum temperature \_\_\_\_\_  
Record the minimum temperature \_\_\_\_\_  
Record the maximum humidity \_\_\_\_\_  
Record the minimum humidity \_\_\_\_\_
- 5. Secure the pelvis to the fixture at the pelvis instrument cavity rear face by threading four ¼x20x½ inch cap screws into the available threaded attachment holes. Tighten the mountings so that the test material is rigidly affixed to the test fixture and the pelvic lumbar joining surface is horizontal. (572.125(c)(3))
- 6. Attach the loading adapter bracket to the spine of the dummy as shown in Figure 7. (572.125(c)(6))
- 7. Flex the dummy forward and back 3 times such that the angle reference plane moves between 0° and 30° with respect to the vertical transverse plane. (572.125(c)(4))
- 8. Support the dummy such that the angle reference plane is at or near 0° (vertical with respect to the vertical transverse plane). Wait at least 30 minutes before continuing. (572.125(c)(4))
- 9. Remove all external support that was implemented above. (572.125(c)(5))
- 10. Measure the initial orientation angle of the torso reference plane of the seated, unsupported dummy. (572.165(c))  
Record reference plane angle (max. allowed 32°) \_\_\_\_\_
- 11. Attach the pull cable and the load cell. (572.125(c)(6))
- 12. Apply a tension force in the midsagittal plane to the pull cable at any upper torso deflection rate between 0.5° and 1.5° per second, until the angle reference plane is at 45° ± 0.5° of flexion relative to the vertical transverse plane. (572.125(c)(7))

- \_\_13. Maintain angle reference plane at  $45^\circ \pm 0.5^\circ$  of flexion for 10 seconds. (572.125(c)(8))
- \_\_14. As quickly as possible release the force applied to the attachment bracket. (572.125(c)(9))
- \_\_15. Three (3) minutes after the release of the force, measure the reference plane angle. (572.125(c)(9))
- \_\_16. Complete the following table:

Torso Flexion Results (572.165(b) and (c), 572.125(c)(7), (572.125(c)(8))

Parameter	Specification	Result
Initial ref. plane angle	Angle $\leq 32^\circ$	
Torso rotation rate	$0.5^\circ/\text{s} \leq \text{rate} \leq 1.5^\circ/\text{s}$	
Force at $45^\circ \pm 0.5^\circ$	$63.6 \text{ N} \leq \text{force} \leq 113.6 \text{ N}$	
Final ref. plane angle	Initial ref. plane angle $\pm 9^\circ$	

\_\_\_\_\_  
Signature

\_\_\_\_\_  
Date



DATA SHEET 8  
LEFT KNEE IMPACT TEST (572.166)

Dummy Serial Number \_\_\_\_\_ Test Date \_\_\_\_\_

Technician \_\_\_\_\_

Pretest calibration  
 Posttest calibration verification

Test attempt no. \_\_\_\_\_ (when successive knee impact tests are necessary)

- 1. It has been at least 30 minutes since the last knee impact test. (572.127(o))  
 N/A, ONLY one knee impact test performed
- 2. The test fixture conforms to the specifications in Figure 8.
- 3. The knee assembly consisting of the knee machined (127-4013), knee flesh (127-4011), lower leg (127-4014), foot assembly (127-4030-1), and femur load transducer (SA572-S10) (may use the load cell structural replacement (127-4007)) were used. (572.126(b))
- 4. The knee assembly soaked at a temperature between 18.9°C (66°F) and 25.6°C (78°F) and at a relative humidity from 10% to 70% for a period of at least four (4) hours prior to this test. (572.126(c)(1))  
Record the maximum temperature \_\_\_\_\_  
Record the minimum temperature \_\_\_\_\_  
Record the maximum humidity \_\_\_\_\_  
Record the minimum humidity \_\_\_\_\_
- 5. Mount the test specimen and secure it to the rigid test fixture. (572.126(c)(2))
- 6. No parts of the foot or tibia contact any exterior surface. (572.126(c)(2))
- 7. Align the test probe so that throughout its stroke and at contact with the knee it is within 2 degrees of horizontal and collinear with the longitudinal centerline of the femur. (572.126(c)(3))
- 8. The probe is guided so there is no significant lateral, vertical or rotational movement during the impact with the knee. (572.126(c)(4))
- 9. The data acquisition system, including transducers, must conform to the requirements of SAE Recommended Practice J211/1 MAR95 (572.127(k)) Class 600.
- 10. Contact the knee with the test probe at a speed between 2.07 m/s and 2.13 m/s. (572.126(c)(5)) Neither the suspension hardware, suspension cables, nor other attachments to the probe, including the velocity vane, make contact with the dummy. (572.126(c)(6))
- 11. Complete the following table:

Knee Impact Results (572.126(b)(1) and 572.126(c)(5))

Parameter	Specification	Result
Probe speed	2.07 m/s ≤ speed ≤ 2.13 m/s	
Peak resistance force*	2000 N ≤ force ≤ 3000 N	

\*Force = impactor mass x deceleration

\_\_12. Plots of acceleration versus time and force versus time follow this sheet.

\_\_\_\_\_  
Signature

\_\_\_\_\_  
Date

DATA SHEET 9  
RIGHT KNEE IMPACT TEST (572.166)

Dummy Serial Number \_\_\_\_\_ Test Date \_\_\_\_\_

Technician \_\_\_\_\_

Pretest calibration  
 Posttest calibration verification

Test attempt no. \_\_\_\_\_ (when successive knee impact tests are necessary)

- 1. It has been at least 30 minutes since the last knee impact test. (572.127(o))  
 N/A, ONLY one knee impact test performed
- 2. The test fixture conforms to the specifications in Figure 8.
- 3. The knee assembly consisting of the knee machined (127-4013), knee flesh (127-4011), lower leg (127-4014), foot assembly (127-4030-2), and femur load transducer (SA572-S10) (may use the load cell structural replacement (127-4007)) were used. (572.126(b))
- 4. The knee assembly soaked at a temperature between 18.9°C (66°F) and 25.6°C (78°F) and at a relative humidity from 10% to 70% for a period of at least four (4) hours prior to this test. (572.126(c)(1))  
Record the maximum temperature \_\_\_\_\_  
Record the minimum temperature \_\_\_\_\_  
Record the maximum humidity \_\_\_\_\_  
Record the minimum humidity \_\_\_\_\_
- 5. Mount the test specimen and secure it to the rigid test fixture. (572.126(c)(2))
- 6. No parts of the foot or tibia contact any exterior surface. (572.126(c)(2))
- 7. Align the test probe so that throughout its stroke and at contact with the knee it is within 2 degrees of horizontal and collinear with the longitudinal centerline of the femur. (572.126(c)(3))
- 8. The probe is guided so there is no significant lateral, vertical or rotational movement during the impact with the knee. (572.126(c)(4))
- 9. The data acquisition system, including transducers, must conform to the requirements of SAE Recommended Practice J211/1 MAR95 (572.127(k)) Class 600.
- 10. Contact the knee with the test probe at a speed between 2.07 m/s and 2.13 m/s. (572.126(c)(5)) Neither the suspension hardware, suspension cables, nor other attachments to the probe, including the velocity vane, make contact with the dummy. (572.126(c)(6))
- 11. Complete the following table:

Knee Impact Results (572.126(b)(1) and 572.126(c)(5))

Parameter	Specification	Result
Probe speed	2.07 m/s ≤ speed ≤ 2.13 m/s	
Peak resistance force*	2000 N ≤ force ≤ 3000 N	

\*Force = impactor mass x deceleration

\_\_12. Plots of acceleration versus time and force versus time follow this sheet.

\_\_\_\_\_  
Signature

\_\_\_\_\_  
Date

DATA SHEET 10  
PART 572 INSTRUMENTATION CALIBRATION INFORMATION

I.D. NO.	MANUFACTURER	MODEL NO.	SERIAL NO.	DATE OF LAST CALIBRATION	DATE OF NEXT CALIBRATION
<b>DUMMY INSTRUMENTATION</b>					
<b>HEAD ACCELEROMETERS</b>					
(1) LONGITUDINAL					
(2) LATERAL					
(3) VERTICAL					
NECK TRANSDUCER					
<b>CHEST ACCELEROMETERS</b>					
(1) LONGITUDINAL					
(2) LATERAL					
(3) VERTICAL					
CHEST POTENTIOMETER					
<b>FEMUR LOAD CELLS</b>					
(1) RIGHT FEMUR					
(2) LEFT FEMUR					
<b>LABORATORY INSTRUMENTATION</b>					
NECK PENDULUM ACCELEROMETER					
THORAX PENDULUM ACCELEROMETER					
KNEE PENDULUM ACCELEROMETER					
NECK ROTATION TRANSDUCER 1 (OPTIONAL)					
NECK ROTATION TRANSDUCER 2 (OPTIONAL)					

LABORATORY TECHNICIAN: \_\_\_\_\_

APPENDIX A: 6YO HIII STORAGE CHAIR DRAWING PACKAGE



HIII STORAGE  
CHAIR -  
SMALL

March 2011

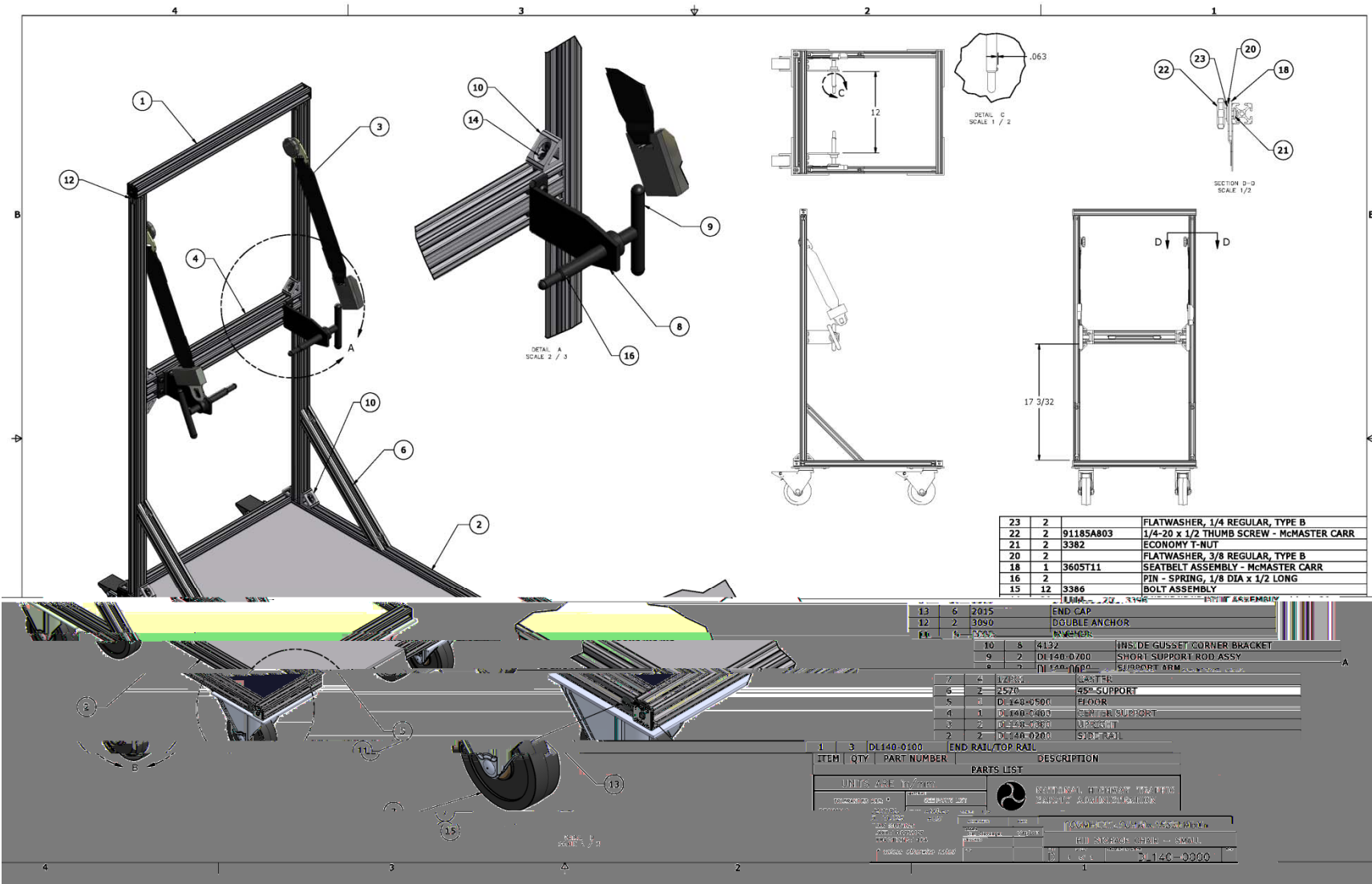

TP572-S-00

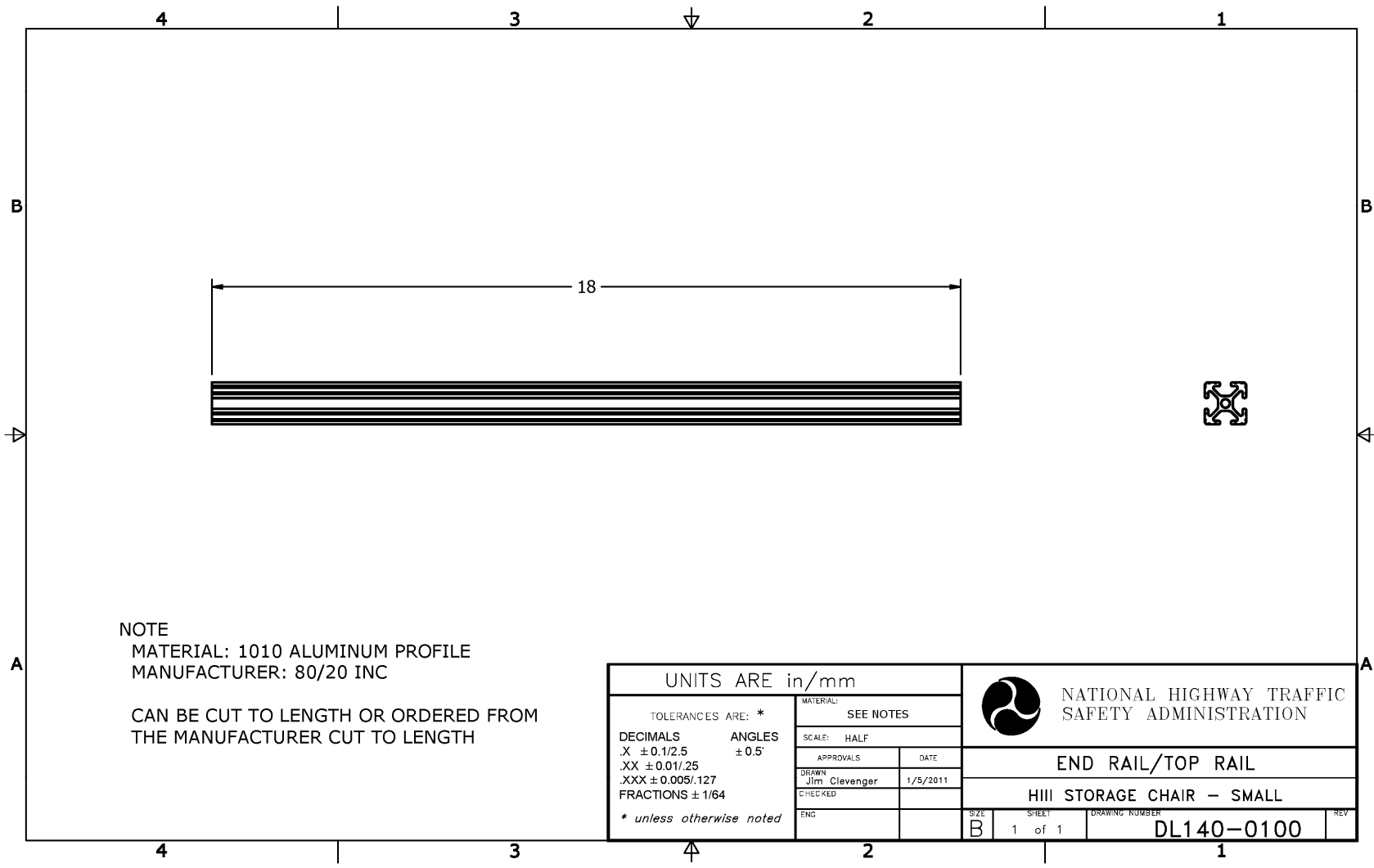

NOTE  
 MATERIAL: 1010 ALUMINUM PROFILE  
 MANUFACTURER: 80/20 INC  
  
 CAN BE CUT TO LENGTH OR ORDERED FROM  
 THE MANUFACTURER CUT TO LENGTH

UNITS ARE in/mm		MATERIAL: SEE NOTES		 NATIONAL HIGHWAY TRAFFIC SAFETY ADMINISTRATION
TOLERANCES ARE: *		SCALE: HALF		
DECIMALS	ANGLES	APPROVALS	DATE	END RAIL/TOP RAIL
.X ± 0.1/2.5	± 0.5°	DRAWN Jim Clevenger	1/5/2011	HIII STORAGE CHAIR - SMALL
.XX ± 0.01/.25		CHECKED		SIZE B
.XXX ± 0.005/.127		ENG		SHEET 1 of 1
FRACTIONS ± 1/64				DRAWING NUMBER DL140-0100
* unless otherwise noted				REV



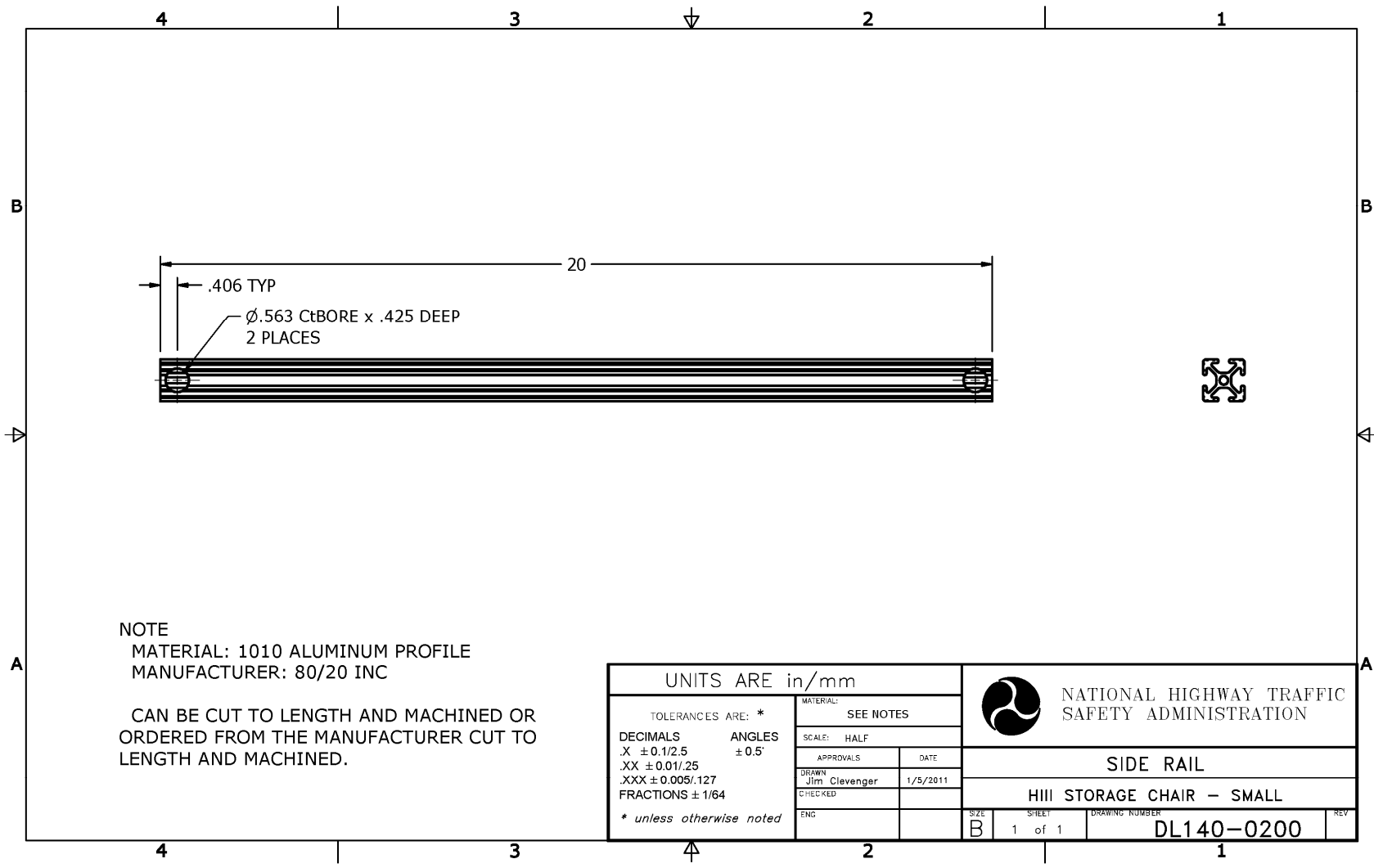

NOTE  
 MATERIAL: 1010 ALUMINUM PROFILE  
 MANUFACTURER: 80/20 INC

CAN BE CUT TO LENGTH AND MACHINED OR  
 ORDERED FROM THE MANUFACTURER CUT TO  
 LENGTH AND MACHINED.

UNITS ARE in/mm	
TOLERANCES ARE: *	
DECIMALS	ANGLES
.X ± 0.1/2.5	± 0.5°
.XX ± 0.01/.25	
.XXX ± 0.005/.127	
FRACTIONS ± 1/64	
* unless otherwise noted	

MATERIAL: SEE NOTES		 NATIONAL HIGHWAY TRAFFIC SAFETY ADMINISTRATION
SCALE: HALF		
APPROVALS	DATE	SIDE RAIL
DRAWN Jim Clevenger	1/5/2011	HIII STORAGE CHAIR - SMALL
CHECKED		SIZE B
ENG		SHEET 1 of 1
		DRAWING NUMBER DL140-0200
		REV

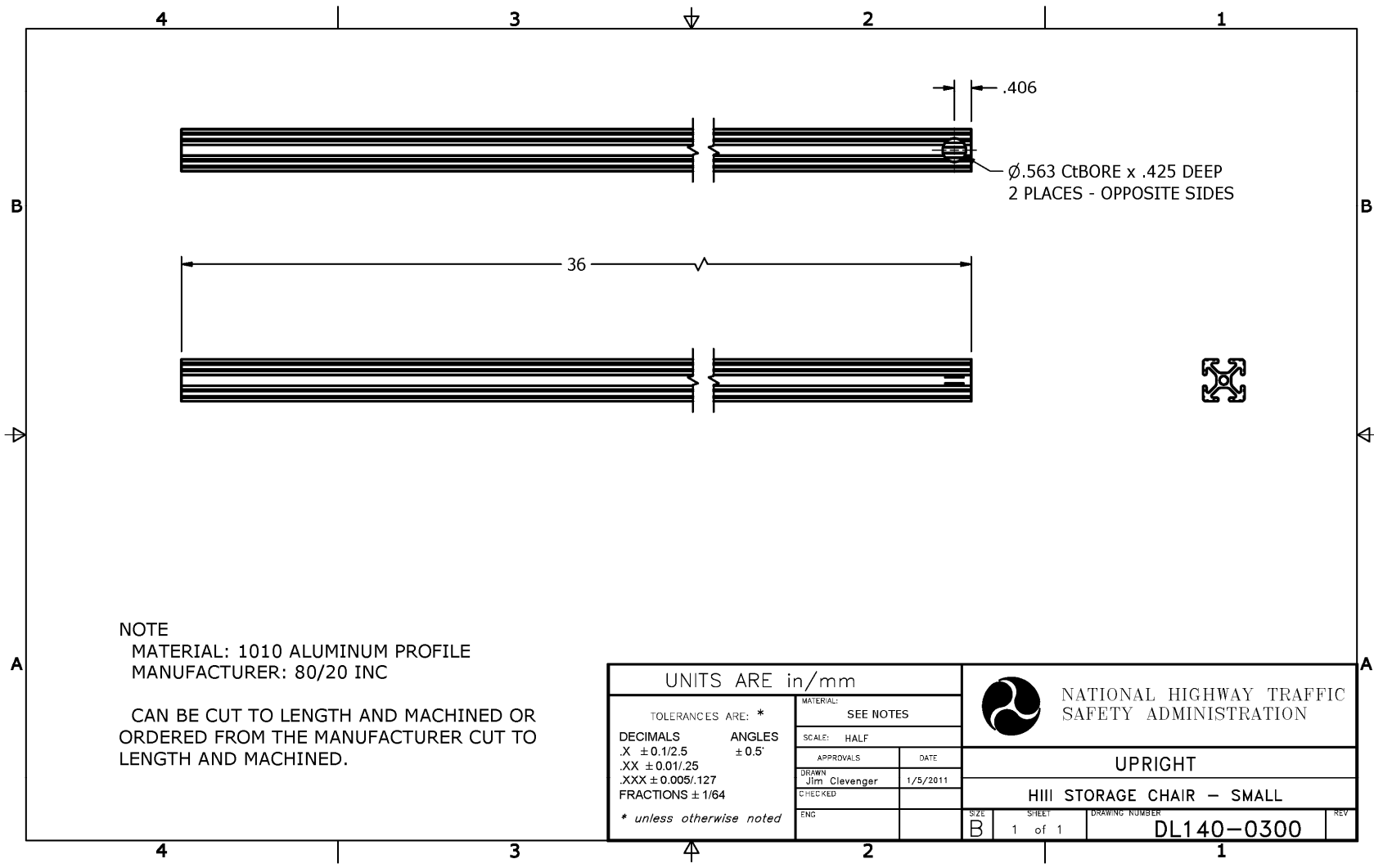

NOTE  
 MATERIAL: 1010 ALUMINUM PROFILE  
 MANUFACTURER: 80/20 INC

CAN BE CUT TO LENGTH AND MACHINED OR  
 ORDERED FROM THE MANUFACTURER CUT TO  
 LENGTH AND MACHINED.

UNITS ARE in/mm	
TOLERANCES ARE: *	MATERIAL: SEE NOTES
DECIMALS	SCALE: HALF
.X ± 0.1/2.5	APPROVALS
.XX ± 0.01/.25	Jim Clevenger
.XXX ± 0.005/.127	DATE
FRACTIONS ± 1/64	1/5/2011
* unless otherwise noted	CHECKED
	ENG

 NATIONAL HIGHWAY TRAFFIC SAFETY ADMINISTRATION	UPRIGHT	
	HIII STORAGE CHAIR - SMALL	
	SIZE B	1 of 1
DRAWING NUMBER		REV
DL140-0300		

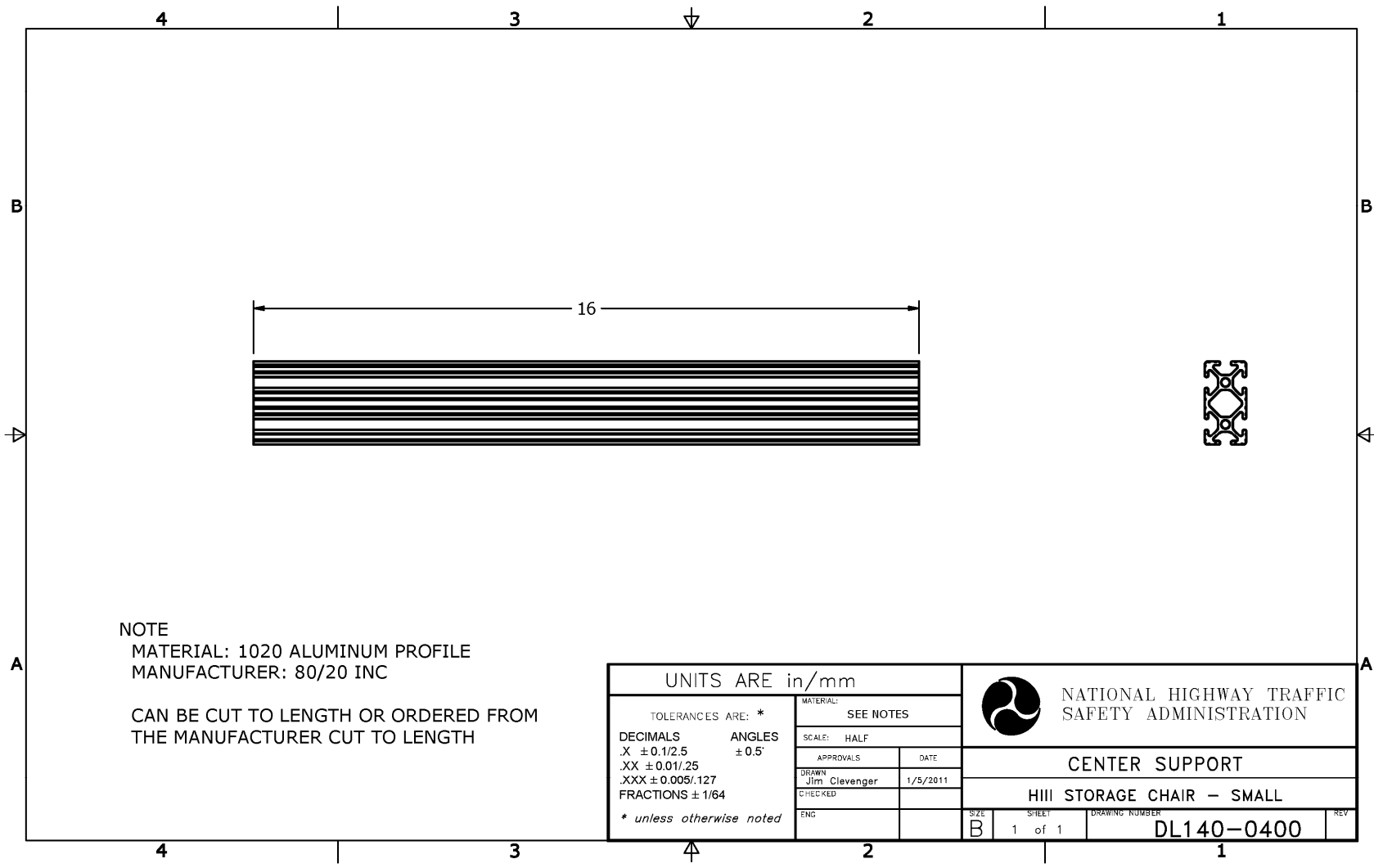

NOTE  
 MATERIAL: 1020 ALUMINUM PROFILE  
 MANUFACTURER: 80/20 INC  
  
 CAN BE CUT TO LENGTH OR ORDERED FROM  
 THE MANUFACTURER CUT TO LENGTH

UNITS ARE in/mm	
TOLERANCES ARE: *	
DECIMALS	ANGLES
.X ± 0.1/2.5	± 0.5°
.XX ± 0.01/.25	
.XXX ± 0.005/.127	
FRACTIONS ± 1/64	
* unless otherwise noted	

MATERIAL: SEE NOTES		 NATIONAL HIGHWAY TRAFFIC SAFETY ADMINISTRATION
SCALE: HALF		
APPROVALS	DATE	CENTER SUPPORT
DRAWN Jim Clevenger	1/5/2011	HIII STORAGE CHAIR - SMALL
CHECKED		SIZE B
ENG		SHEET 1 of 1
		DRAWING NUMBER DL140-0400
		REV

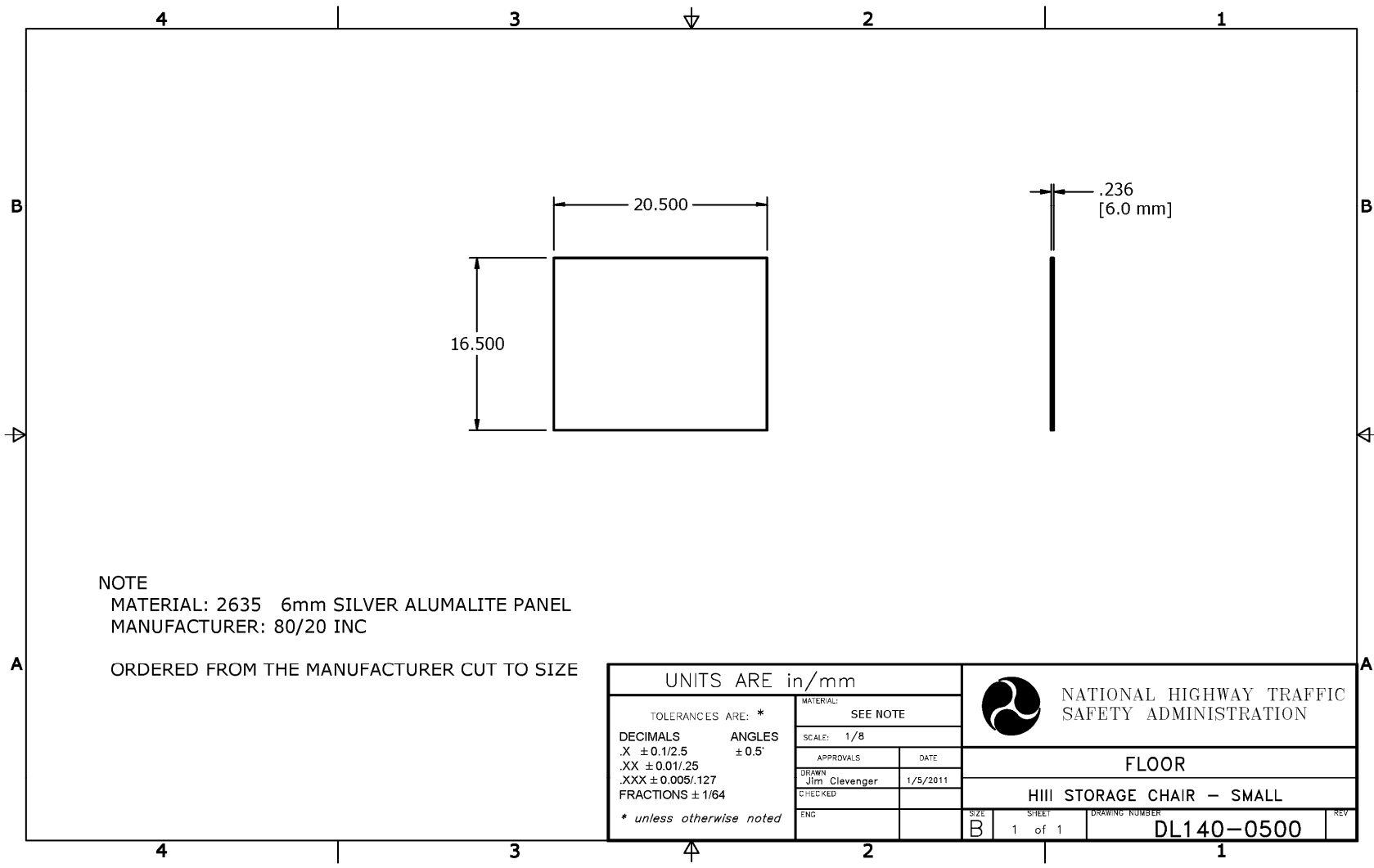

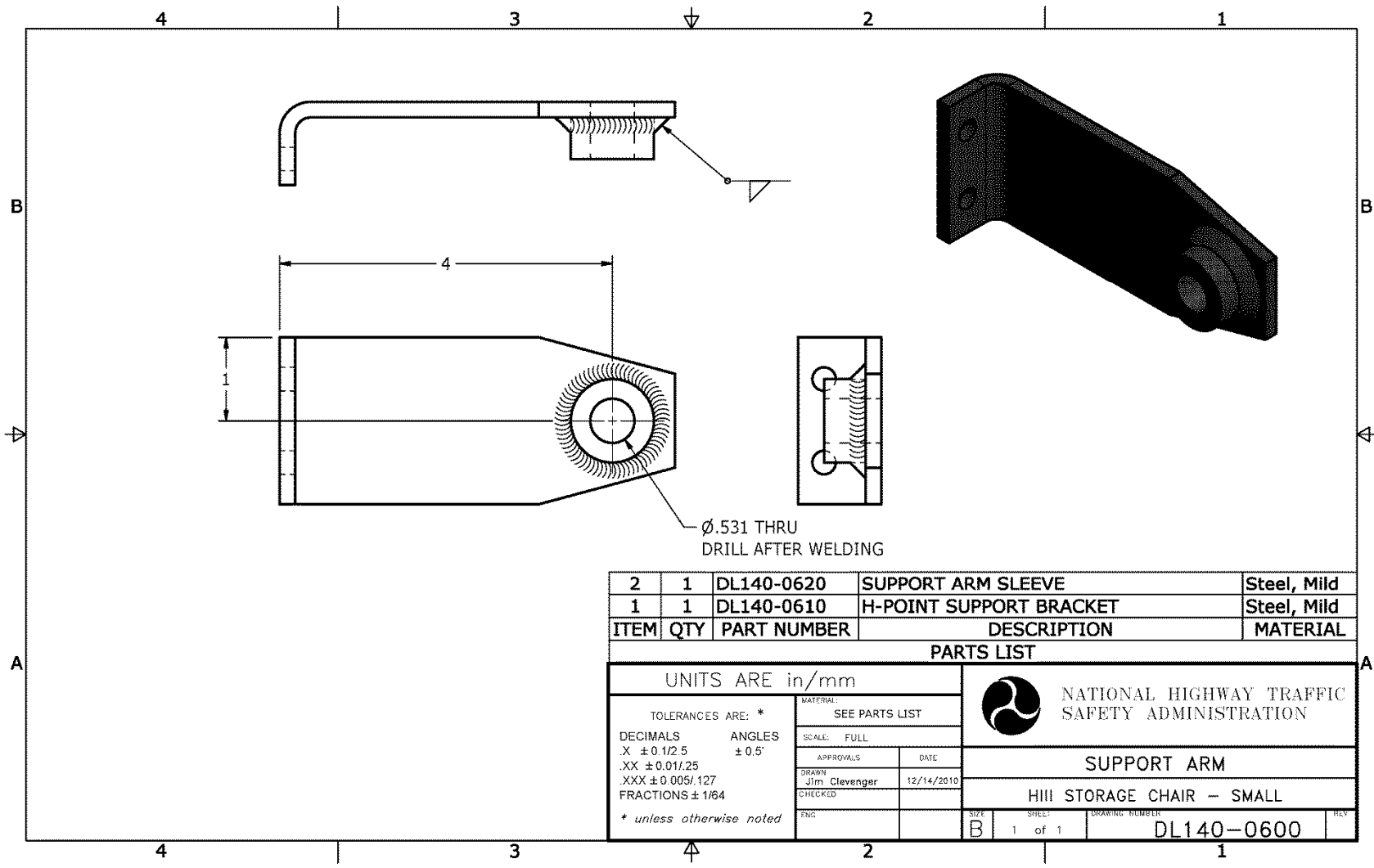



2	1	DL140-0620	SUPPORT ARM SLEEVE	Steel, Mild
1	1	DL140-0610	H-POINT SUPPORT BRACKET	Steel, Mild
ITEM	QTY	PART NUMBER	DESCRIPTION	MATERIAL

**PARTS LIST**

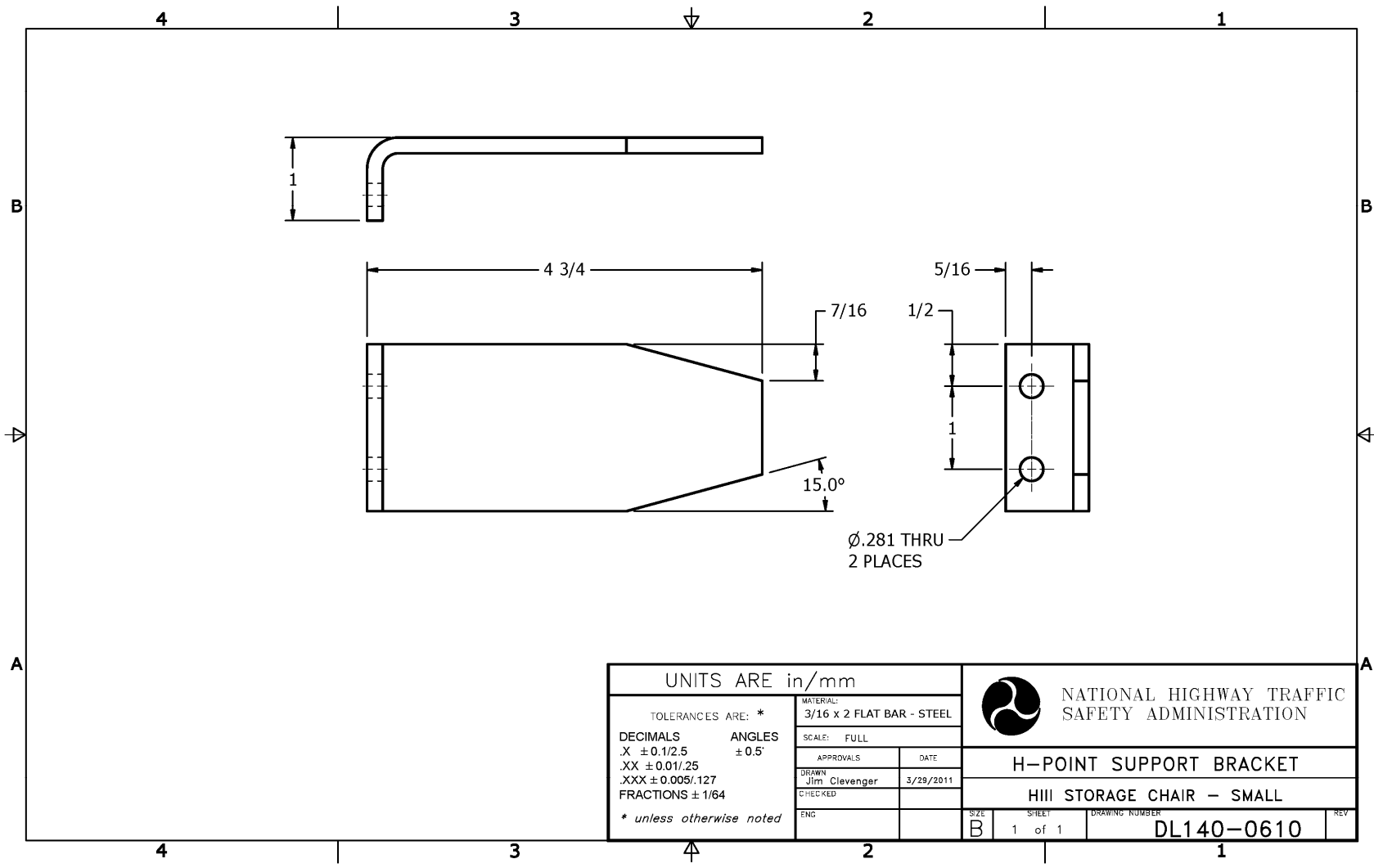
UNITS ARE in/mm		MATERIAL: SEE PARTS LIST		 NATIONAL HIGHWAY TRAFFIC SAFETY ADMINISTRATION
TOLERANCES ARE: * DECIMALS            ANGLES .X ± 0.1/2.5           ± 0.5° .XX ± 0.01/25 .XXX ± 0.005/127 FRACTIONS ± 1/64 * unless otherwise noted		SCALE: FULL	DATE	
		APPROVALS	DATE	SUPPORT ARM
		DRAWN Jim Clevenger	12/14/2010	HIII STORAGE CHAIR - SMALL
		CHECKED		SIZE B    SHEET 1 of 1    DRAWING NUMBER DL140-0600    REV



UNITS ARE in/mm		MATERIAL: 3/16 x 2 FLAT BAR - STEEL		 NATIONAL HIGHWAY TRAFFIC SAFETY ADMINISTRATION	
TOLERANCES ARE: *		SCALE: FULL		H-POINT SUPPORT BRACKET	
DECIMALS	ANGLES	APPROVALS	DATE	HIII STORAGE CHAIR - SMALL	
.X ± 0.1/2.5	± 0.5°	Jim Clevenger	3/29/2011	SIZE	SHEET
.XX ± 0.01/.25		CHECKED		B	1 of 1
.XXX ± 0.005/.127		ENG		DRAWING NUMBER	
FRACTIONS ± 1/64				DL140-0610	
* unless otherwise noted				REV	

