

**BeiDou Navigation Satellite System  
Signal In Space  
Interface Control Document**

**Open Service Signal B1I (Version 1.0)**



**China Satellite Navigation Office**

**December 2012**



# Content

1	Statement .....	1
2	Scope .....	1
3	BeiDou System Overview .....	1
3.1	Space Constellation .....	1
3.2	Coordinate System.....	1
3.3	Time System.....	2
4	Signal Specifications .....	3
4.1	Signal Structure .....	3
4.2	Signal Characteristics .....	3
4.2.1	Carrier Frequency .....	3
4.2.2	Modulation Mode .....	3
4.2.3	Polarization Mode .....	4
4.2.4	Carrier Phase Noise .....	4
4.2.5	User-Received Signal Power Level.....	4
4.2.6	Signal Multiplexing Mode .....	4
4.2.7	Satellite Signal Bandwidth and Out-band Suppression .....	5
4.2.8	Spurious .....	5
4.2.9	Signal Coherence.....	5
4.2.10	Equipment Group Delay Differential .....	5
4.3	Ranging Code on B1I .....	6

5	NAV Message .....	8
5.1	General .....	8
5.1.1	NAV Message Classification .....	8
5.1.2	NAV Message Information Type and Broadcasting.....	9
5.1.3	Data Error Correction Coding Mode.....	11
5.2	D1 NAV Message .....	15
5.2.1	Secondary Code Modulated on D1 .....	15
5.2.2	D1 NAV Message Frame Structure .....	16
5.2.3	D1 NAV Message Detailed Structure.....	17
5.2.4	D1 NAV Message Content and Algorithm .....	24
5.3	D2 NAV Message .....	42
5.3.1	D2 NAV Message Frame Structure .....	42
5.3.2	D2 NAV Message Detailed structure .....	43
5.3.3	D2 NAV Message Content and Algorithm .....	67
6	Acronyms.....	76

## **1 Statement**

BeiDou Navigation Satellite System Signal-In-Space Interface Control Document (hereafter referred to as ICD) is issued by the China Satellite Navigation Office, which reserves the right for final explanation.

## **2 Scope**

This ICD defines the specification related to open service signal B1I between the space segment and the user segment of the BeiDou Navigation Satellite System.

## **3 BeiDou System Overview**

### **3.1 Space Constellation**

BeiDou Navigation Satellite System is called BeiDou System for short, with the abbreviation as BDS. When fully deployed, the space constellation of BDS consists of five Geostationary Earth Orbit (GEO) satellites, twenty-seven Medium Earth Orbit (MEO) satellites and three Inclined Geosynchronous Satellite Orbit (IGSO) satellites. The GEO satellites are operating in orbit at an altitude of 35,786 kilometers and positioned at 58.75 °E, 80 °E, 110.5 °E, 140 °E and 160 °E respectively. The MEO satellites are operating in orbit at an altitude of 21,528 kilometers and an inclination of 55 ° to the equatorial plane. The IGSO satellites are operating in orbit at an altitude of 35,786 kilometers and an inclination of 55 ° to the equatorial plane.

By the end of 2012, there are five GEO, four MEO and five IGSO BeiDou navigation satellites in orbit.

### **3.2 Coordinate System**

BDS adopts the China Geodetic Coordinate System 2000 (CGCS2000),

and the definition is listed below:

The origin is located at the mass center of the Earth;

The Z-axis is in the direction of the IERS (International Earth Rotation and Reference System Service) Reference Pole (IRP);

The X-axis is directed to the intersection of IERS Reference Meridian (IRM) and the plane passing the origin and normal to the Z-axis;

The Y-axis, together with Z-axis and X-axis, constitutes a right handed orthogonal coordinate system.

The origin of the CGCS2000 is also the geometric center of the CGCS2000 ellipsoid, and the Z-axis is the rotation axis of the CGCS2000 ellipsoid. The parameters of the CGCS2000 ellipsoid are as follows:

Semi-major axis:  $a = 6378137.0 \text{ m}$

Geocentric gravitational constant (mass of the earth atmosphere included):

$$\mu = 3.986004418 \times 10^{14} \text{ m}^3/\text{s}^2$$

Flattening:  $f = 1/298.257222101$

Rate of earth rotation:  $\dot{\Omega}_e = 7.2921150 \times 10^{-5} \text{ rad/s}$

### 3.3 Time System

The time reference for the BDS uses the BeiDou navigation satellite system Time (BDT). BDT adopts international system of units (SI) seconds, rather than leap seconds, as the basic unit for continuous accumulation. The start epoch of BDT was 00:00:00 on January 1, 2006 of Coordinated Universal Time (UTC). BDT is counted with week and seconds of week (SOW). BDT is related to the UTC through UTC(NTSC). BDT offset with respect to UTC is controlled within 100 nanoseconds (modulo 1 second). The leap seconds are broadcast in navigation (NAV) message.

## 4 Signal Specifications

### 4.1 Signal Structure

The B1 signal is the sum of channel I and Q which are in phase quadrature of each other. The ranging code and NAV message are modulated on carrier. The signal is composed of the carrier frequency, ranging code and NAV message.

The B1 signal is expressed as follows:

$$S^j(t) = A_I C_I^j(t) D_I^j(t) \cos(2\pi f_0 t + \varphi^j) + A_Q C_Q^j(t) D_Q^j(t) \sin(2\pi f_0 t + \varphi^j)$$

Where,

Superscript j: satellite number;

Subscript I: channel I;

Subscript Q: channel Q;

A: signal amplitude;

C: ranging code;

D: data modulated on ranging code;

$f_0$ : carrier frequency;

$\varphi$ : carrier initial phase.

### 4.2 Signal Characteristics

#### 4.2.1 Carrier Frequency

The nominal frequency of B1I signal is 1561.098 MHz.

#### 4.2.2 Modulation Mode

The transmitted signal is modulated by Quadrature Phase Shift Keying (QPSK).

### 4.2.3 Polarization Mode

The transmitted signal shall be Right-Handed Circularly Polarized (RHCP). The signal polarization ellipticity is specified in Table 4-1.

Tab 4-1 Signal polarization ellipticity

Satellite type	Signal polarization ellipticity
GEO	Ellipticity is no worse than 2.9 dB, angular range: $\pm 10^\circ$ from boresight.
MEO	Ellipticity is no worse than 2.9 dB, angular range: $\pm 15^\circ$ from boresight.
IGSO	Ellipticity is no worse than 2.9 dB, angular range: $\pm 10^\circ$ from boresight.

### 4.2.4 Carrier Phase Noise

The phase noise spectral density of the unmodulated carrier is as follows:

- 60 dBc/Hz @  $f_0 \pm 10$  Hz
- 75 dBc/Hz @  $f_0 \pm 100$  Hz
- 80 dBc/Hz @  $f_0 \pm 1$  kHz
- 85 dBc/Hz @  $f_0 \pm 10$  kHz
- 95 dBc/Hz @  $f_0 \pm 100$  kHz

Where  $f_0$  is the carrier frequency of B1I.

### 4.2.5 User-Received Signal Power Level

The minimum user-received signal power level is specified to be -163 dBW for B1I, which is measured at the output of a 0 dB RHCP receiving antenna (located near ground), when the satellite's elevation angle is higher than 5 degree.

### 4.2.6 Signal Multiplexing Mode

The signal multiplexing mode is Code Division Multiple Access (CDMA).



### 4.2.7 Satellite Signal Bandwidth and Out-band Suppression

- (1) Bandwidth (1 dB): 4.092 MHz (centered at carrier frequency of B1I);  
Bandwidth (3 dB): 16 MHz (centered at carrier frequency of B1I).
- (2) Out-band suppression: no less than 15 dB on  $f_0 \pm 30$  MHz, where  $f_0$  is the carrier frequency of B1I signal.

### 4.2.8 Spurious

In-band spurious shall be at least 50 dB below the unmodulated carrier of B1I over the satellite signal bandwidth (1 dB).

### 4.2.9 Signal Coherence

- (1) The random jitter of the initial phase difference between the ranging code modulated on carrier and carrier is less than  $3^\circ (1\sigma)$  (relative to the carrier) for B1I signal.
- (2) Carrier phase quadrature difference between channel I and Q is less than  $5^\circ (1\sigma)$ .

### 4.2.10 Equipment Group Delay Differential

Equipment group delay is defined as the delay between the antenna phase center of a satellite and the output of the satellite onboard frequency source. The equipment group delay differential of B1I is given as  $T_{GD1}$  in NAV message with uncertainty less than 1 nanosecond ( $1\sigma$ ).

### 4.3 Ranging Code on B1I

The chip rate of the B1I ranging code is 2.046 Mcps, and the length is 2046 chips.

The B1I ranging code (hereinafter referred to as  $C_{B1I}$ ) is a balanced Gold code truncated with the last one chip. The Gold code is generated by means of Modulo-2 addition of G1 and G2 sequences which are respectively derived from two 11-bit linear shift registers.

The generator polynomials for G1 and G2 are as follows:

$$G1(X)=1+X+X^7+X^8+X^9+X^{10}+X^{11}$$

$$G2(X)=1+X+X^2+X^3+X^4+X^5+X^8+X^9+X^{11}$$

The initial phases of G1 and G2 are:

G1: 01010101010

G2: 01010101010

The generator of  $C_{B1I}$  is shown in Figure 4-1.

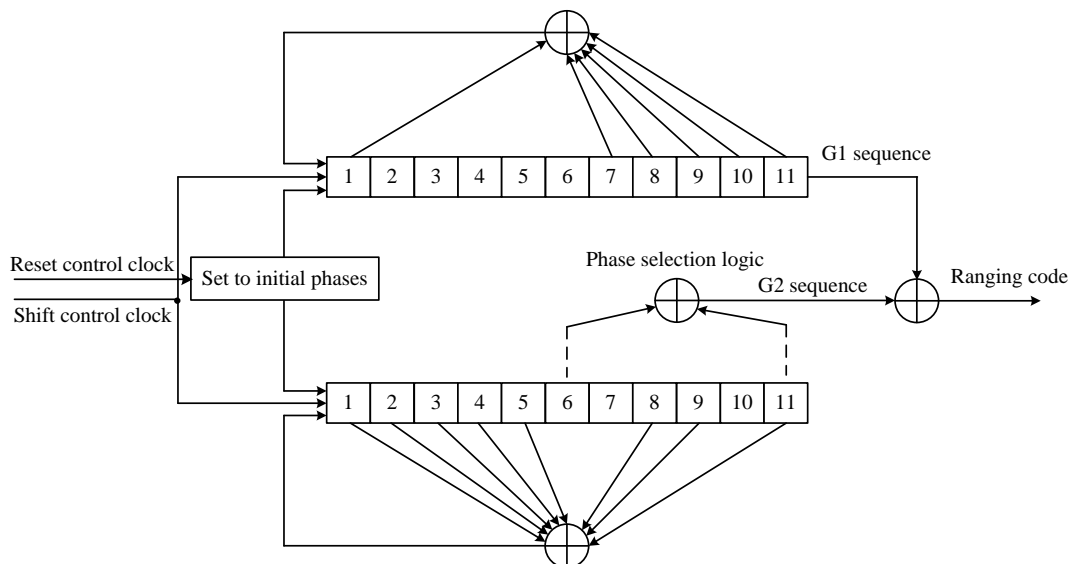

**Figure 4-1 The generator of  $C_{B1I}$**

The different phase shift of G2 sequence is accomplished by respective tapping in the shift register generating G2 sequence. By means of Modulo-2 addition of G2 with different phase shift and G1, a ranging code is generated for

each satellite.

The phase assignment of G2 sequence is shown in Table 4-2.

**Table 4-2 Phase assignment of G2 sequence**

No.	Satellite type	Ranging code number	Phase assignment of G2 sequence
1	GEO satellite	1	1 ⊕ 3
2	GEO satellite	2	1 ⊕ 4
3	GEO satellite	3	1 ⊕ 5
4	GEO satellite	4	1 ⊕ 6
5	GEO satellite	5	1 ⊕ 8
6	MEO/IGSO satellite	6	1 ⊕ 9
7	MEO/IGSO satellite	7	1 ⊕ 10
8	MEO/IGSO satellite	8	1 ⊕ 11
9	MEO/IGSO satellite	9	2 ⊕ 7
10	MEO/IGSO satellite	10	3 ⊕ 4
11	MEO/IGSO satellite	11	3 ⊕ 5
12	MEO/IGSO satellite	12	3 ⊕ 6
13	MEO/IGSO satellite	13	3 ⊕ 8
14	MEO/IGSO satellite	14	3 ⊕ 9
15	MEO/IGSO satellite	15	3 ⊕ 10
16	MEO/IGSO satellite	16	3 ⊕ 11
17	MEO/IGSO satellite	17	4 ⊕ 5
18	MEO/IGSO satellite	18	4 ⊕ 6
19	MEO/IGSO satellite	19	4 ⊕ 8
20	MEO/IGSO satellite	20	4 ⊕ 9
21	MEO/IGSO satellite	21	4 ⊕ 10
22	MEO/IGSO satellite	22	4 ⊕ 11
23	MEO/IGSO satellite	23	5 ⊕ 6
24	MEO/IGSO satellite	24	5 ⊕ 8
25	MEO/IGSO satellite	25	5 ⊕ 9

No.	Satellite type	Ranging code number	Phase assignment of G2 sequence
26	MEO/IGSO satellite	26	5 ⊕ 10
27	MEO/IGSO satellite	27	5 ⊕ 11
28	MEO/IGSO satellite	28	6 ⊕ 8
29	MEO/IGSO satellite	29	6 ⊕ 9
30	MEO/IGSO satellite	30	6 ⊕ 10
31	MEO/IGSO satellite	31	6 ⊕ 11
32	MEO/IGSO satellite	32	8 ⊕ 9
33	MEO/IGSO satellite	33	8 ⊕ 10
34	MEO/IGSO satellite	34	8 ⊕ 11
35	MEO/IGSO satellite	35	9 ⊕ 10
36	MEO/IGSO satellite	36	9 ⊕ 11
37	MEO/IGSO satellite	37	10 ⊕ 11

## 5 NAV Message

### 5.1 General

#### 5.1.1 NAV Message Classification

NAV messages are formatted in D1 and D2 based on their rate and structure. The rate of D1 NAV message which is modulated with 1 kbps secondary code is 50 bps. D1 NAV message contains basic NAV information (fundamental NAV information of the broadcasting satellites, almanac information for all satellites as well as the time offsets from other systems); while D2 NAV message contains basic NAV and augmentation service information (the BDS integrity, differential and ionospheric grid information) and its rate is 500 bps.

The NAV message broadcast by MEO/IGSO and GEO satellites is D1 and D2 respectively.

## **5.1.2 NAV Message Information Type and Broadcasting**

The NAV message information type and broadcasting are shown in Table 5-1. The detailed structure, bits allocations, contents and algorithms will be described in later chapters.

**Tab 5-1 NAV message information contents and their broadcasting**

Message information content		No. of Bits	Broadcasting
Preamble (Pre)		11	Occurring every subframe
Subframe ID (FraID)		3	
Seconds of week (SOW)		20	
Fundamental NAV information of the broadcasting satellite	Week number (WN)	13	D1: broadcast in subframes 1, 2 and 3, repeated every 30 seconds. D2: broadcast in the first five words of pages 1~10 of subframe 1, repeated every 30 seconds. Updating rate: every 1 hour.
	User range accuracy index (URAI)	4	
	Autonomous satellite health flag (SatH1)	1	
	Equipment group delay differential ( $T_{GD1}$ )	10	
	Issue of data, clock (IODC)	5	
	Clock correction parameters ( $t_{oc}, a_0, a_1, a_2$ )	74	
	Issue of data, ephemeris (IODE)	5	
	Ephemeris parameters ( $t_{oe}, \sqrt{A}, e, \omega, \Delta n, M_0, \Omega_0, \dot{\Omega}, i_0, IDOT, C_{uc}, C_{us}, C_{rc}, C_{rs}, C_{ic}, C_{is}$ )	371	
Ionosphere model parameters ( $\alpha_n, \beta_n, n=0\sim 3$ )	64		
Page number (Pnum)		7	D1: broadcast in subframe 4 and subframe 5. D2: broadcast in subframe 5.
Almanac	Almanac parameters ( $t_{oa}, \sqrt{A}, e, \omega, M_0, \Omega_0, \dot{\Omega}, \delta_i, a_0, a_1$ )	176	D1: broadcasting in pages 1~24 of subframe 4 and pages 1~6 of subframe 5, repeated every 12 minutes. D2: broadcast in pages 37~60, 95~100 of subframe 5, repeated every 6 minutes. Updating period: less than 7 days.
	Week number of almanac ( $WN_a$ )	8	D1: broadcast in pages 7~8 of subframe 5, repeated every 12 minutes.
	Health information for 30 satellites ( $Hea_i, i=1\sim 30$ )	9×30	D2: broadcast in pages 35~36 of subframe 5, repeated every 6 minutes. Updating period: less than 7 days.

Basic NAV information, broadcast in every satellite

Message information content		No. of Bits	Broadcasting	
Time offsets from other systems	Time parameters relative to UTC ( $A_{0UTC}$ , $A_{1UTC}$ , $\Delta t_{LS}$ , $\Delta t_{LSF}$ , $WN_{LSF}$ , $DN$ )	88	D1: broadcast in pages 9~10 of subframe 5, repeating every 12 minutes. D2: broadcast in pages 101~102 of subframe 5, repeated every 6 minutes. Updating period: less than 7 days.	
	Time parameters relative to GPS time ( $A_{0GPS}$ , $A_{1GPS}$ )	30		
	Time parameters relative to Galileo time ( $A_{0Gal}$ , $A_{1Gal}$ )	30		
	Time parameters relative to GLONASS time ( $A_{0GLO}$ , $A_{1GLO}$ )	30		
Page number for basic NAV information (Pnum1)		4	D2: broadcast in pages 1~10 of subframe 1.	Integrity and differential correction information and ionospheric grid information are broadcast by GEO satellites only.
Page number for integrity and differential correction information (Pnum2)		4	D2: broadcast in pages 1~6 of subframe 2.	
Satellite health flag for integrity and differential correction information (SatH2)		2	D2: broadcast in pages 1~6 of subframe 2. Updating rate: every 3 seconds.	
BDS Satellite identification for integrity and differential correction information ( $BDID_i$ , $i=1\sim30$ )		$1\times30$	D2: broadcast in pages 1~6 of subframe 2. Updating rate: every 3 seconds.	
Integrity and differential correction information of BDS	User differential range error index ( $UDREI_i$ , $i=1\sim18$ )	$4\times18$	D2: broadcast in subframe 2. Updating rate: every 3 seconds.	
	Regional user range accuracy index ( $RURAI_i$ , $i=1\sim18$ )	$4\times18$	D2: broadcast in subframe 2 and subframe 3. Updating rate: every 18 seconds.	
	Equivalent clock correction ( $\Delta t_i$ , $i=1\sim18$ )	$13\times18$		
Ionospheric grid information	Vertical ionospheric delay at grid point ( $d\tau$ )	$9\times320$	D2: broadcast in pages 1~13, 61~73 of subframe 5. Updating rate: every 6 minutes.	
	Grid ionospheric vertical delay error index (GIVEI)	$4\times320$		

### 5.1.3 Data Error Correction Coding Mode

The NAV message encoding involves both error control of BCH(15,11,1) and interleaving. The BCH code is 15 bits long with 11 information bits and

error correction capability of 1 bit. The generator polynomial is  $g(X)=X^4+X+1$ .

The NAV message bits are grouped every 11 bits in sequence first. The serial/parallel conversion is made and the BCH(15,11,1) error correction encoding is performed in parallel. Parallel/serial conversion is then carried out for every two parallel blocks of BCH codes by turns of 1 bit to form an interleaved code of 30 bits length. The implementation is shown in Figure 5-1.

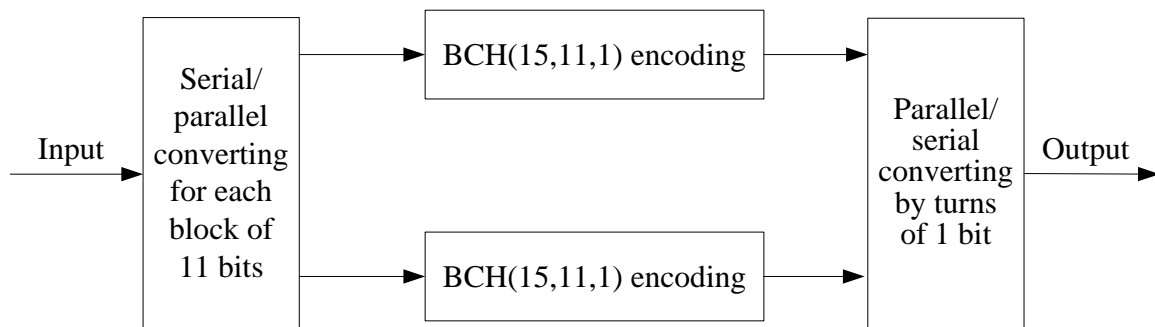

**Fig 5-1 Error correction encoding and interleaving of down-link NAV message**

The implementation of BCH (15,11,1) encoder is shown in Figure 5-2. Initially the four stages of the shift register are all reset to zero, Gate1 is on and Gate2 is off. The 11 bits of information block X are sent into a dividing circuit  $g(X)$ . Meantime the information bits are sent out of the encoder through gate “or” as the output. The dividing operation finishes when all the 11 bits have been sent in and then the states of the four register stages represent the parity check bits. Now switch Gate 1 off and Gate 2 on. The four parity check bits are shifted out of the encoder through gate “or” to form a 15 bits code in combination with the output 11 bits of information block. Then switch Gate1 on and Gate2 off and send in the next information block and the procedure above is repeated again.



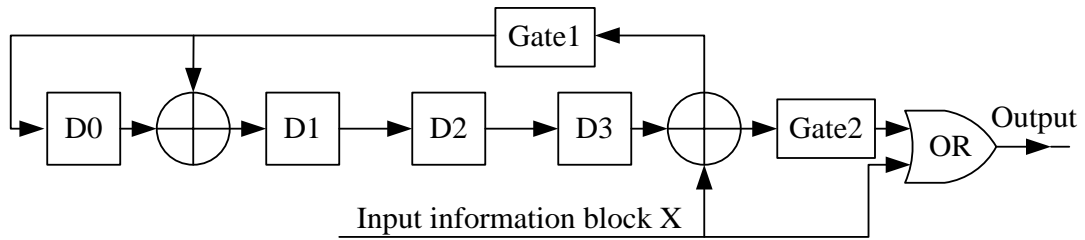

**Fig 5-2 BCH(15, 11, 1) encoder**

For the received NAV message by receivers near ground a serial/parallel conversion by turns of 1 bit is required first, followed by an error correction decoding of BCH(15,11,1) in parallel. Then a parallel/serial conversion is carried out for each 11 bits block to form a 22 bits information code in sequence. The processing is shown in Figure 5-3.

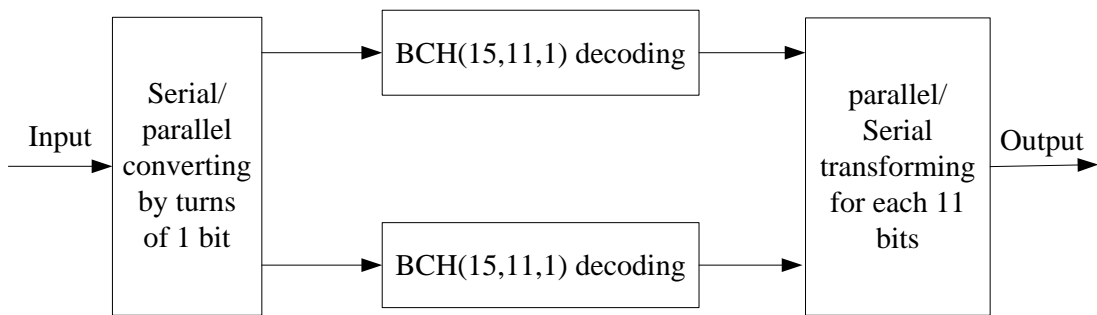

**Fig 5-3 Processing of received down-link NAV message**

The decoding logic of BCH(15,11,1) is shown in Figure 5-4. The initial states of the four register stages are all zeros. BCH codes are sent in bit by bit into a division circuit and a fifteen stages buffer simultaneously. When all fifteen bits of a BCH code are inputted, the ROM list circuit forms a fifteen-bit table based on the states D3, D2, D1 and D0 of the four register stages. Then the 15 bits in the table and 15 bits in the buffer are Modulo-2 added and an error corrected information code obtained is output. The ROM table list is shown in Table 5-2.

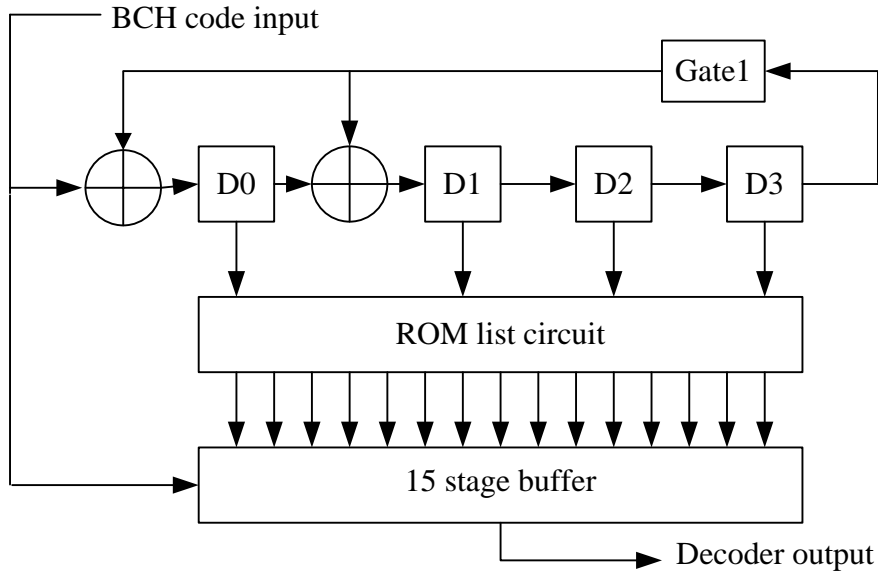

Fig 5-4 BCH(15,11,1) decoding logic

Tab 5-2 ROM table list for error correction

$D_3D_2D_1D_0$	15 bits data for error correction
0000	000000000000000
0001	000000000000001
0010	000000000000010
0011	0000000000010000
0100	000000000000100
0101	000000100000000
0110	000000000100000
0111	000010000000000
1000	000000000001000
1001	100000000000000
1010	000001000000000
1011	000000010000000
1100	000000001000000
1101	010000000000000
1110	000100000000000
1111	001000000000000

The interleaving pattern of 30 bits code is as follows:

$X_1^1$	$X_2^1$	$X_1^2$	$X_2^2$	...	$X_1^{11}$	$X_2^{11}$	$P_1^1$	$P_2^1$	$P_1^2$	$P_2^2$	$P_1^3$	$P_2^3$	$P_1^4$	$P_2^4$
---------	---------	---------	---------	-----	------------	------------	---------	---------	---------	---------	---------	---------	---------	---------

where  $X_i^j$  is the information bit, subscript  $i$  stands for the bit in BCH code of block  $i$  and  $i=1$  or  $2$ ; superscript  $j$  stands for the information bit  $j$  in block  $i$  and  $j=1$  to  $11$ ;  $P_i^m$  is the check parity bit, subscript  $i$  stands for the bit in BCH code of block  $i$  and  $i=1$  or  $2$ ; superscript  $m$  stands for the parity bit  $m$  in BCH code of block  $i$  and  $m=1$  to  $4$ .

## 5.2 D1 NAV Message

### 5.2.1 Secondary Code Modulated on D1

For D1 NAV message in format D1 of rate 50 bps a secondary code of Neumann-Hoffman (NH) code is modulated on ranging code. The period of NH code is selected as long as the duration of a NAV message bit. The bit duration of NH code is the same as one period of the ranging code. Shown as in Figure 5-5, the duration of one NAV message bit is 20 milliseconds and the ranging code period is 1 millisecond. Thus the NH code (0, 0, 0, 0, 0, 1, 0, 0, 1, 1, 0, 1, 0, 1, 0, 0, 1, 1, 1, 0) with length of 20 bits, rate 1 kbps and bit duration of 1 millisecond is adopted. It is modulated on the ranging code synchronously with NAV message bit.

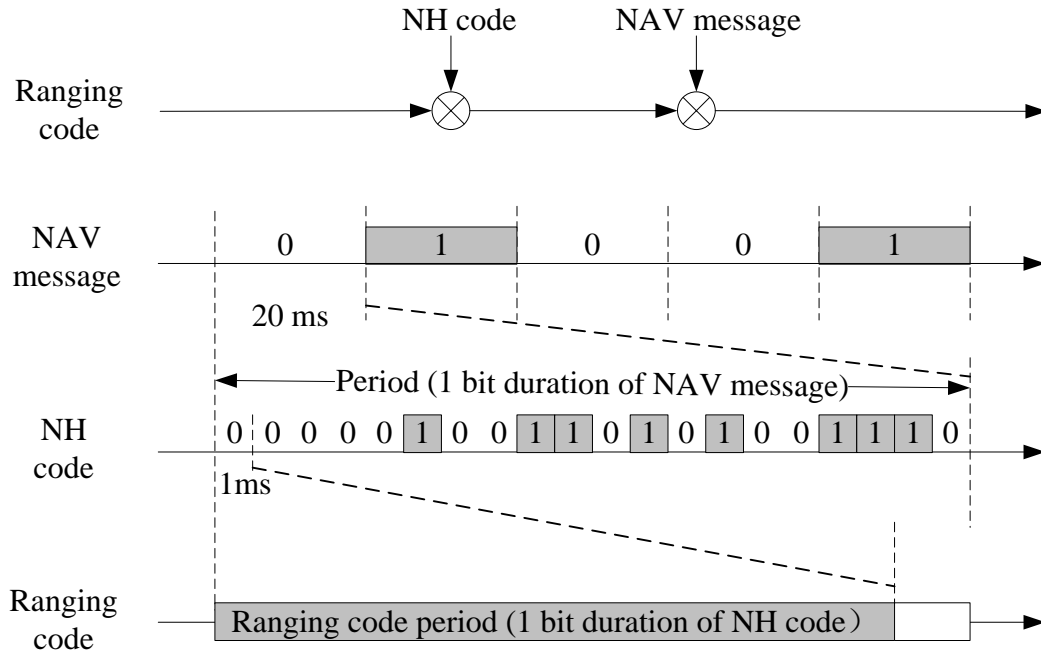

Fig 5-5 Secondary code and its timing

### 5.2.2 D1 NAV Message Frame Structure

The NAV message in format D1 is structured in the superframe, frame and subframe. Every superframe has 36000 bits and lasts 12 minutes. Every superframe is composed of 24 frames (24 pages). Every frame has 1500 bits and lasts 30 seconds. Every frame is composed of 5 subframes. Every subframe has 300 bits and lasts 6 seconds. Every subframe is composed of 10 words. Every word has 30 bits and lasts 0.6 second.

Every word consists of NAV message data and parity bits. In the first word of every subframe, the first 15 bits is not encoded and the following 11 bits are encoded in BCH(15,11,1) for error correction. So there is only one group of BCH code contained and there are altogether 26 information bits in the word. For all the other 9 words in the subframe both BCH(15,11,1) encoding for error control and interleaving are involved. Each of the 9 words of 30 bits contains two blocks of BCH codes and there are altogether 22 information bits in it. (reference paragraph 5.1.3)

The frame structure in format D1 is shown in Figure 5-6.

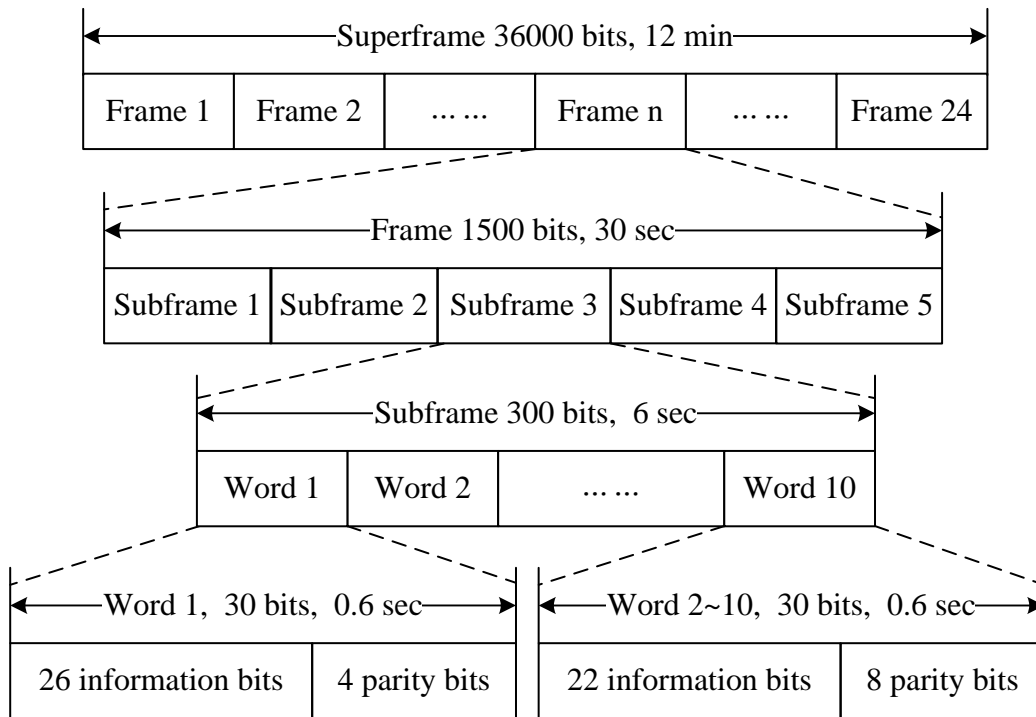

**Fig 5-6 Frame structure of NAV message in format D1**

### 5.2.3 D1 NAV Message Detailed Structure

The main information contents of NAV message in format D1 are basic NAV information, including fundamental NAV information of the broadcasting satellites (seconds of week, week number, user range accuracy index, autonomous satellite health flag, ionospheric delay model parameters, satellite ephemeris parameters and their age, satellite clock correction parameters and their age and equipment group delay differential), almanac and BDT offsets from other systems (UTC and other navigation satellite systems). It takes 12 minutes to transmit the whole NAV message.

The D1 frame structure and information contents are shown in Figure 5-7. The fundamental NAV information of the broadcasting satellite is in subframes 1, 2 and 3. The information contents in subframes 4 and 5 are subcommutated 24 times each via 24 pages. Pages 1~24 of subframe 4 and pages 1~10 of subframe 5 shall be used to broadcast almanac and time offsets from other

systems. Pages 11~24 of subframe 5 are reserved.

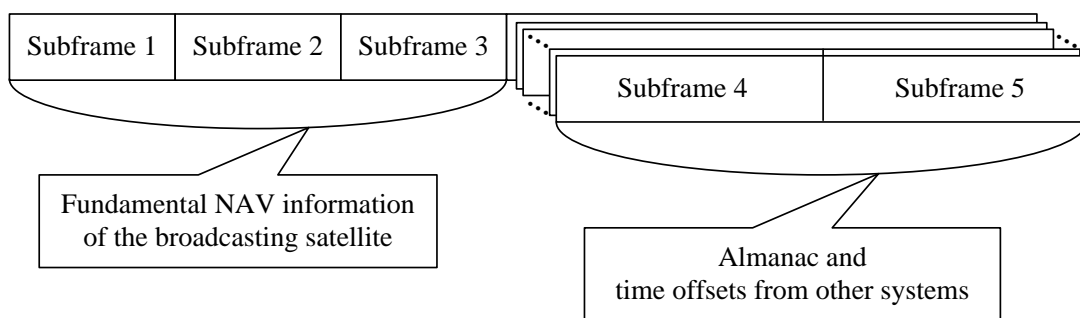

**Fig 5-7 Frame structure and information contents of NAV message in format D1**

The bits allocations of format D1 are shown in Figure 5-8~5-11.

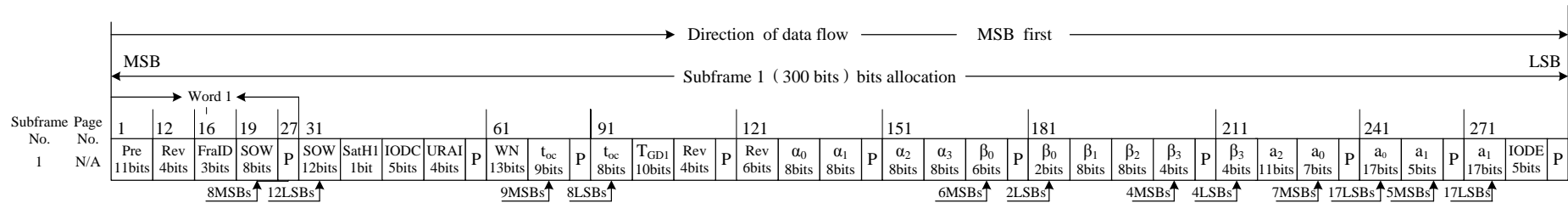

Fig 5-8 Bits allocation of subframe 1 in format D1

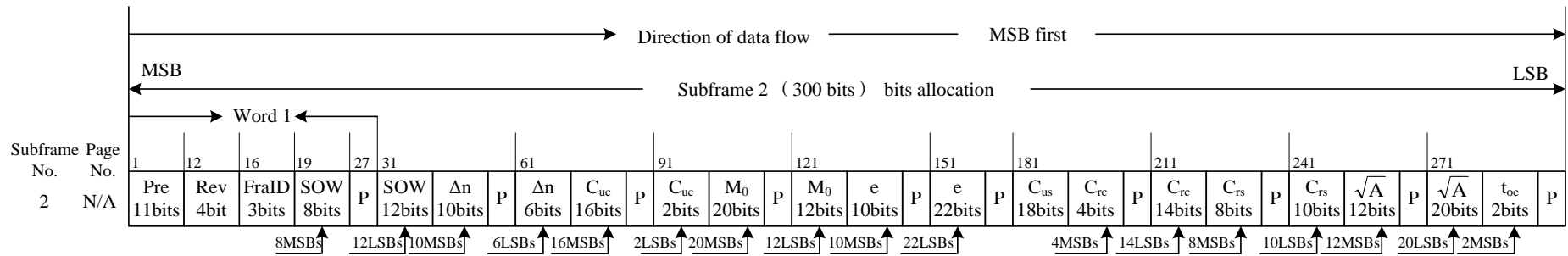
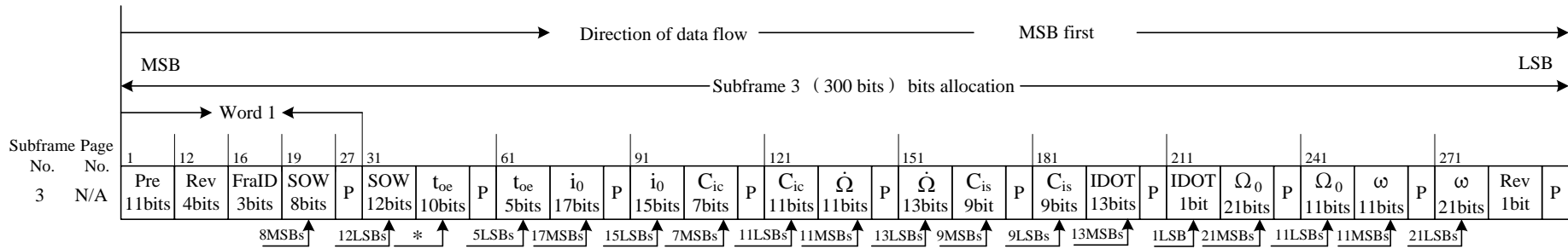
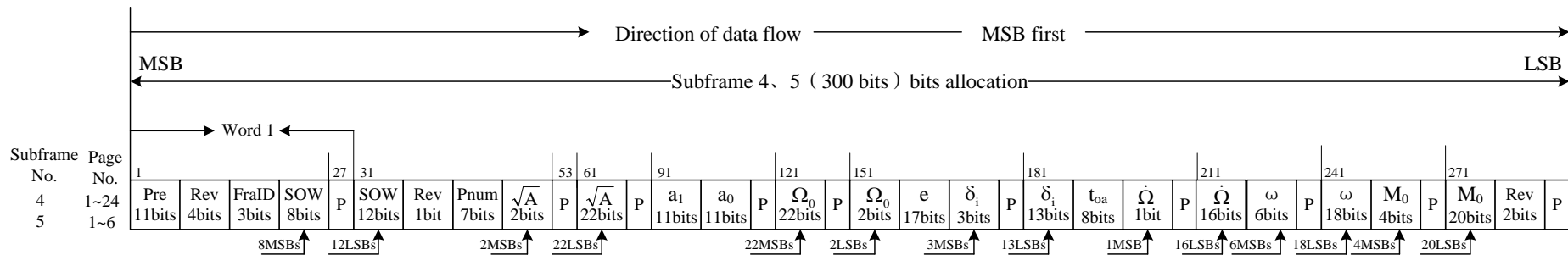

Fig 5-9 Bits allocation of subframe 2 in format D1



\* These are data bits next to MSBs and before LSBs.

**Fig 5-10 Bits allocation of subframe 3 in format D1**



**Fig 5-11-1 Bits allocation of pages 1 through 24 in subframe 4 and pages 1 through 6 in subframe 5 of format D1**



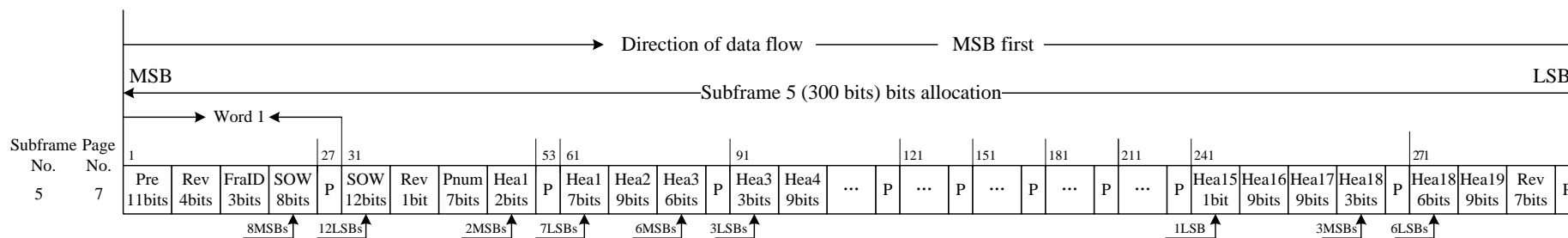

Fig 5-11-2 Bits allocation of page 7 in subframe 5 of format D1

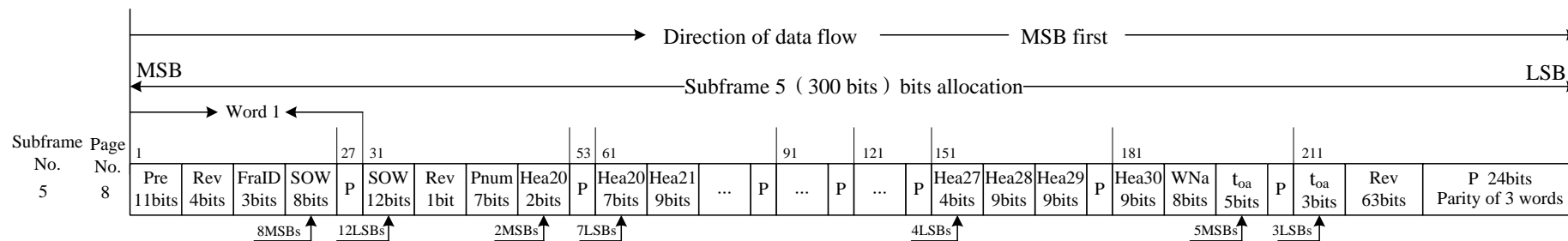

Fig 5-11-3 Bits allocation of page 8 in subframe 5 of format D1

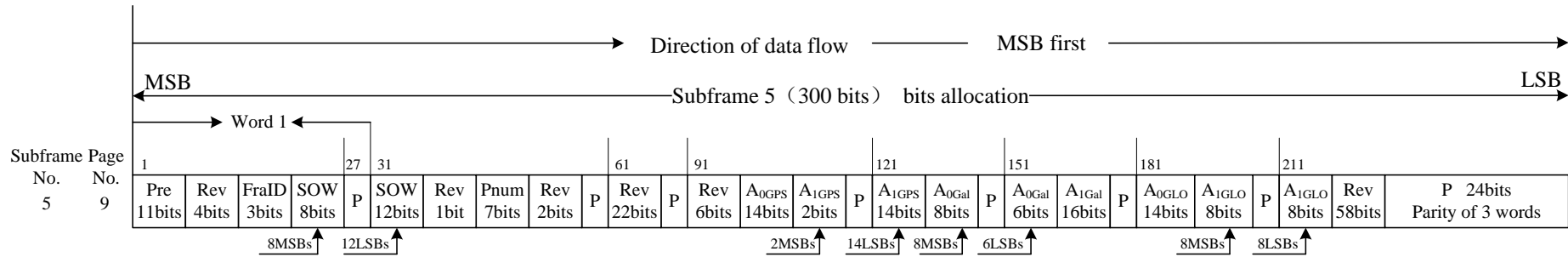

Fig 5-11-4 Bits allocation of page 9 in subframe 5 of format D1

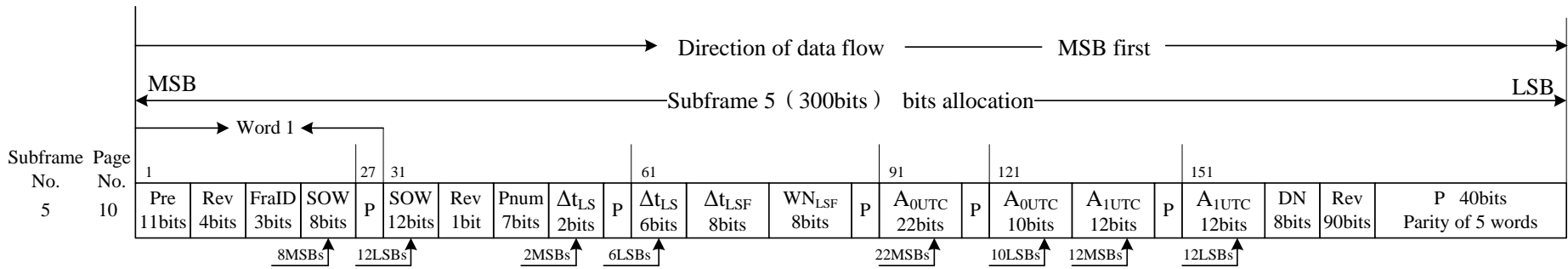
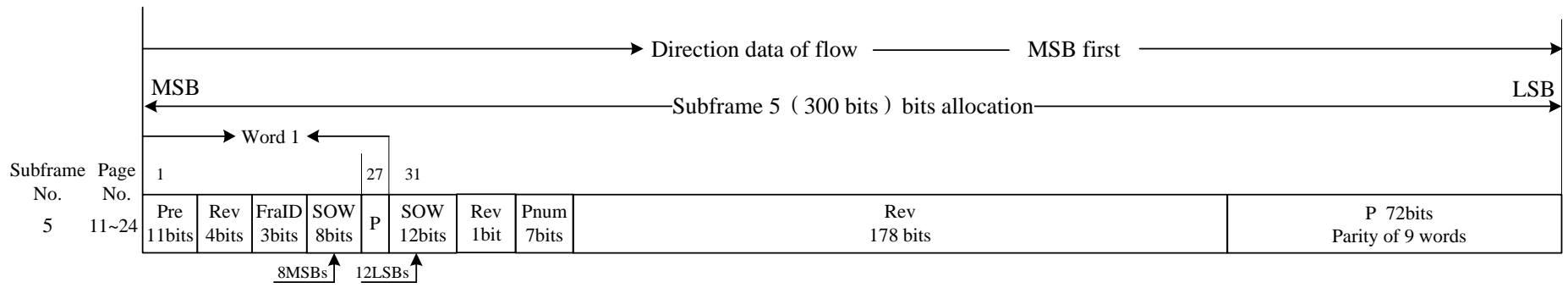

Fig 5-11-5 Bits allocation of page 10 in subframe 5 of format D1



**Fig 5-11-6 Bits allocation of reserved pages 11~24 in format D1 subframe**

## 5.2.4 D1 NAV Message Content and Algorithm

### 5.2.4.1 Preamble (Pre)

The bits 1~11 of every subframe are preamble (Pre) of “11100010010” from modified Barker code of 11 bits. SOW count occurs at the leading edge of the preamble first bit which is for time scale synchronization.

### 5.2.4.2 Subframe identification (FraID)

The bits 16, 17 and 18 of every subframe are for subframe identification (FraID). The detailed definitions are as follows:

**Tab 5-3 FraID definitions**

Code	001	010	011	100	101	110	111
Identification of subframe	1	2	3	4	5	Rev	Rev

### 5.2.4.3 Seconds of Week (SOW)

The bits 19~26 and bits 31~42, altogether 20 bits of the each subframe are for seconds of week (SOW) which is defined as the number of seconds that have occurred since the last Sunday, 00:00:00 of BDT. The SOW count occurs at the leading edge of preamble first bit of the subframe.

### 5.2.4.4 Week Number (WN)

There are altogether 13 bits for week number (WN) which is the integral week count of BDT with the range of 0 through 8191. Week number count started from zero at 00:00:00 on Jan. 1, 2006 of BDT.

### 5.2.4.5 User Range Accuracy Index (URAI)

The user range accuracy (URA) is used to describe the signal-in-space accuracy in meters. There are 4 bits for the user range accuracy index (URAI). The range of URAI is from 0 to 15. See Table 5-4 for the corresponding relationship between URAI and URA.

**Tab 5-4 Corresponding relationship between URAI and URA**

Code	URAI (N)	URA range (meters, $1\sigma$ )
0000	0	$0.00 < \text{URA} \leq 2.40$
0001	1	$2.40 < \text{URA} \leq 3.40$
0010	2	$3.40 < \text{URA} \leq 4.85$
0011	3	$4.85 < \text{URA} \leq 6.85$
0100	4	$6.85 < \text{URA} \leq 9.65$
0101	5	$9.65 < \text{URA} \leq 13.65$
0110	6	$13.65 < \text{URA} \leq 24.00$
0111	7	$24.00 < \text{URA} \leq 48.00$
1000	8	$48.00 < \text{URA} \leq 96.00$
1001	9	$96.00 < \text{URA} \leq 192.00$
1010	10	$192.00 < \text{URA} \leq 384.00$
1011	11	$384.00 < \text{URA} \leq 768.00$
1100	12	$768.00 < \text{URA} \leq 1536.00$
1101	13	$1536.00 < \text{URA} \leq 3072.00$
1110	14	$3072.00 < \text{URA} \leq 6144.00$
1111	15	$\text{URA} > 6144.00$

When an URAI is received by the user, the corresponding URA (X) is computed by the following equations:

$$\text{If } 0 \leq N < 6, X = 2^{N/2+1};$$

$$\text{If } 6 \leq N < 15, X = 2^{N-2};$$

If  $N=15$ , it means the satellite is in maneuver or there is no accuracy

prediction;

If N=1, 3 and 5, X should be rounded to 2.8, 5.7, and 11.3 meters, respectively.

#### 5.2.4.6 Autonomous Satellite Health flag (SatH1)

The autonomous satellite health flag (SatH1) occupies 1 bit. “0” means broadcasting satellite is good and “1” means not.

#### 5.2.4.7 Ionospheric Delay Model Parameters ( $\alpha_n, \beta_n$ )

There are 8 parameters, altogether 64 bits for ionospheric delay model. All the 8 parameters are in two’s complement. See Table 5-5 for details.

**Tab 5-5 Ionospheric delay model parameters**

Parameter	No. of bits	Scale factor (LSB)	Units
$\alpha_0$	8*	$2^{-30}$	s
$\alpha_1$	8*	$2^{-27}$	s/ $\pi$
$\alpha_2$	8*	$2^{-24}$	s/ $\pi^2$
$\alpha_3$	8*	$2^{-24}$	s/ $\pi^3$
$\beta_0$	8*	$2^{11}$	s
$\beta_1$	8*	$2^{14}$	s/ $\pi$
$\beta_2$	8*	$2^{16}$	s/ $\pi^2$
$\beta_3$	8*	$2^{16}$	s/ $\pi^3$

\* Parameters so indicated are two’s complement, with the sign bit (+ or -) occupying the MSB.

The user computers the vertical ionospheric delay correction  $I_z'(t)$  with the 8 parameters and Klobuchar model as follows:

$$I_z'(t) = \begin{cases} 5 \times 10^{-9} + A_2 \cos\left[\frac{2\pi(t - 50400)}{A_4}\right], & |t - 50400| < A_4 / 4 \\ 5 \times 10^{-9} & , |t - 50400| \geq A_4 / 4 \end{cases}$$

Where  $I_z'(t)$  is the vertical ionospheric delay in seconds for B1I,  $t$  is the local time (range 0~86400 sec) for the place under the intersection point (M) of ionosphere and the direction from receiver to satellite.

$A_2$  is the amplitude of Klobuchar cosine curve in the day time computed from the  $\alpha_n$ .

$$A_2 = \begin{cases} \sum_{n=0}^3 \alpha_n |\phi_M|^n, & A_2 \geq 0 \\ 0 & , \quad A_2 < 0 \end{cases}$$

$A_4$  is the period of cosine curve in seconds. It is computed from the  $\beta_n$ .

$$A_4 = \begin{cases} 172800 & , \quad A_4 \geq 172800 \\ \sum_{n=0}^3 \beta_n |\phi_M|^n, & 172800 > A_4 \geq 72000 \\ 72000 & , \quad A_4 < 72000 \end{cases}$$

Where  $\phi_M$  is the geographic latitude of earth projection of the ionosphere intersection point in semi-circles ( $\pi$ ). The geographic latitude  $\phi_M$  and longitude  $\lambda_M$  of the intersection point M are computed as:

$$\phi_M = \arcsin(\sin \phi_u \cos \psi + \cos \phi_u \sin \psi \cos A)$$

$$\lambda_M = \lambda_u + \arcsin\left(\frac{\sin \psi \cdot \sin A}{\cos \phi_M}\right)$$

Where  $\phi_u$  is the user's geographic latitude in radians.  $A$  is the satellite azimuth from the user location in radians.  $\psi$  is the earth's central angle in radians between the user location and ionospheric intersection point. It is computed as:

$$\psi = \frac{\pi}{2} - E - \arcsin\left(\frac{R}{R+h} \cdot \cos E\right)$$

Where  $R$  is the mean radius of the earth (6378 km).  $E$  is the satellite elevation from the user's location in radians.  $h$  is the height of ionosphere (375 km).

$I'_z(t)$  can be converted to the ionospheric delay along the B1I propagation path  $I_{B1I}(t)$  through the equation as follows and the unit is seconds.

$$I_{B1I}(t) = \frac{1}{\sqrt{1 - \left(\frac{R}{R+h} \cdot \cos E\right)^2}} \cdot I'_z(t)$$

Note: When user adopt this model in the south hemisphere, the ionospheric correction accuracy is slightly lower than that in the north.

#### 5.2.4.8 Equipment Group Delay Differential ( $T_{GD1}$ )

The equipment group delay differential ( $T_{GD1}$ ) in the satellite is given in 10 bits. It is in two's complement with sign bit (+ or -) occupying MSB. Sign bit "0" means positive and "1" means negative. The scale factor is 0.1 and the unit is nanoseconds.

#### 5.2.4.9 Issue of Data, Clock (IODC)

Issue of data, clock (IODC) is 5 bits long with definitions as follows:

**Tab 5-6 IODC definitions**

IODC	Definition
< 25	Age of the satellite clock correction parameters in hours
25	Age of the satellite clock correction parameters is two days
26	Age of the satellite clock correction parameters is three days
27	Age of the satellite clock correction parameters is four days
28	Age of the satellite clock correction parameters is five days
29	Age of the satellite clock correction parameters is six days
30	Age of the satellite clock correction parameters is seven days
31	Age of the satellite clock correction parameters is over seven days



### 5.2.4.10 Clock Correction Parameters ( $t_{oc}$ , $a_0$ , $a_1$ , $a_2$ )

Clock correction parameters are  $t_{oc}$ ,  $a_0$ ,  $a_1$  and  $a_2$  in 74 bits altogether.  $t_{oc}$  is the reference time of clock parameters in seconds with the effective range of 0~604792. Other 3 parameters are two's complement.

The definitions of clock correction parameters are listed in Table 5-7.

**Tab 5-7 Clock correction parameters**

Parameter	No. of bits	Scale factor (LSB)	Effective range	Units
$t_{oc}$	17	$2^3$	604792	s
$a_0$	24*	$2^{-33}$	—	s
$a_1$	22*	$2^{-50}$	—	s/s
$a_2$	11*	$2^{-66}$	—	s/s <sup>2</sup>

\* Parameters so indicated are two's complement, with the sign bit (+ or -) occupying the MSB.

The system time computation is as follows:

The user is able to compute BDT at time of signal transmission as:

$$t = t_{sv} - \Delta t_{sv}$$

where,  $t$  is BDT in seconds at time of signal transmission;

$t_{sv}$  is the effective satellite ranging code phase time in seconds at time of signal transmission;

$\Delta t_{sv}$  is the offset of satellite ranging code phase time in seconds and is given by the equation:

$$\Delta t_{sv} = a_0 + a_1(t - t_{oc}) + a_2(t - t_{oc})^2 + \Delta t_r$$

Where,  $t$  can be replaced by  $t_{sv}$  regardless of its sensitivity.

$\Delta t_r$  is the correction term to relativistic effect with value of

$$\Delta t_r = F \cdot e \cdot \sqrt{A} \cdot \sin E_k$$

$e$  is the orbit eccentricity, which is given in ephemeris of the broadcasting satellite;

$\sqrt{A}$  is the square root of semi-major axis of satellite orbit, which is given in ephemeris of the broadcasting satellite;

$E_k$  is eccentric anomaly of satellite orbit, which is given in ephemeris of the broadcasting satellite;

$$F = -2\mu^{1/2}/C^2 = -4.442807633 \times 10^{-10} \text{ s/m}^{1/2};$$

$\mu = 3.986004418 \times 10^{14} \text{ m}^3/\text{s}^2$ , is the value of earth's universal gravitational constant;

$$C = 2.99792458 \times 10^8 \text{ m/s}, \text{ is the light speed.}$$

The user working on B1I should make a further correction as follows:

$$(\Delta t_{sv})_{B1I} = \Delta t_{sv} - T_{GD1}$$

#### 5.2.4.11 Issue of Data, Ephemeris (IODE)

The issue of data, ephemeris (IODE) is 5 bits long with definitions as follows:

**Tab 5-8 IODE definitions**

IODE	Definition
< 25	Age of the satellite ephemeris parameters in hours
25	Age of the satellite ephemeris parameters is two days
26	Age of the satellite ephemeris parameters is three days
27	Age of the satellite ephemeris parameters is four days
28	Age of the satellite ephemeris parameters is five days
29	Age of the satellite ephemeris parameters is six days
30	Age of the satellite ephemeris parameters is seven days
31	Age of the satellite ephemeris parameters is over seven days

### 5.2.4.12 Ephemeris Parameters ( $t_{oe}$ , $\sqrt{A}$ , $e$ , $\omega$ , $\Delta n$ , $M_0$ , $\Omega_0$ , $\dot{\Omega}$ , $i_0$ , IDOT, $C_{uc}$ , $C_{us}$ , $C_{rc}$ , $C_{rs}$ , $C_{ic}$ , $C_{is}$ )

The ephemeris parameters describe the satellite orbit during the curve fit interval, including 15 orbit parameters and an ephemeris reference time. The update rate of ephemeris parameters is one hour.

The definitions of ephemeris parameters are listed in Table 5-9.

**Tab 5-9 Ephemeris Parameters definitions**

Parameter	Definition
$t_{oe}$	Ephemeris reference time
$\sqrt{A}$	Square root of semi-major axis
$e$	Eccentricity
$\omega$	Argument of perigee
$\Delta n$	Mean motion difference from computed value
$M_0$	Mean anomaly at reference time
$\Omega_0$	Longitude of ascending node of orbital of plane computed according to reference time
$\dot{\Omega}$	Rate of right ascension
$i_0$	Inclination angle at reference time
IDOT	Rate of inclination angle
$C_{uc}$	Amplitude of cosine harmonic correction term to the argument of latitude
$C_{us}$	Amplitude of sine harmonic correction term to the argument of latitude
$C_{rc}$	Amplitude of cosine harmonic correction term to the orbit radius
$C_{rs}$	Amplitude of sine harmonic correction term to the orbit radius
$C_{ic}$	Amplitude of cosine harmonic correction term to the angle of inclination
$C_{is}$	Amplitude of sine harmonic correction term to the angle of inclination

Characteristics of ephemeris parameters are shown in Table 5-10.

Tab 5-10 Ephemeris parameters characteristics

Parameter	No. of Bits	Scale factor (LSB)	Effective Range	Units
$t_{oe}$	17	$2^3$	604792	s
$\sqrt{A}$	32	$2^{-19}$	8192	$m^{1/2}$
$e$	32	$2^{-33}$	0.5	—
$\omega$	$32^*$	$2^{-31}$	$\pm 1$	$\pi$
$\Delta n$	$16^*$	$2^{-43}$	$\pm 3.73 \times 10^{-9}$	$\pi/s$
$M_0$	$32^*$	$2^{-31}$	$\pm 1$	$\pi$
$\Omega_0$	$32^*$	$2^{-31}$	$\pm 1$	$\pi$
$\dot{\Omega}$	$24^*$	$2^{-43}$	$\pm 9.54 \times 10^{-7}$	$\pi/s$
$i_0$	$32^*$	$2^{-31}$	$\pm 1$	$\pi$
IDOT	$14^*$	$2^{-43}$	$\pm 9.31 \times 10^{-10}$	$\pi/s$
$C_{uc}$	$18^*$	$2^{-31}$	$\pm 6.10 \times 10^{-5}$	rad
$C_{us}$	$18^*$	$2^{-31}$	$\pm 6.10 \times 10^{-5}$	rad
$C_{rc}$	$18^*$	$2^{-6}$	$\pm 2048$	m
$C_{rs}$	$18^*$	$2^{-6}$	$\pm 2048$	m
$C_{ic}$	$18^*$	$2^{-31}$	$\pm 6.10 \times 10^{-5}$	rad
$C_{is}$	$18^*$	$2^{-31}$	$\pm 6.10 \times 10^{-5}$	rad

\* Parameters so indicated are two's complement, with the sign bit (+ or -) occupying the MSB.

The user receiver shall compute the satellite antenna phase center position in coordinate system CGCS2000 according to the received ephemeris parameters. The algorithms are listed in Table 5-11.

Tab 5-11 Ephemeris algorithm for user

Computation	Description
$\mu = 3.986004418 \times 10^{14} \text{ m}^3/\text{s}^2$	Value of the earth's universal gravitational constant of CGCS2000
$\dot{\Omega}_e = 7.2921150 \times 10^{-5} \text{ rad/s}$	Value of the earth's rotation rate of CGCS2000
$\pi = 3.1415926535898$	

Computation	Description
$A = (\sqrt{A})^2$	Computed semi-major axis
$n_0 = \sqrt{\frac{\mu}{A^3}}$	Computed mean motion (radians/sec)
$t_k = t - t_{oe}^*$	Computed time from ephemeris reference time
$n = n_0 + \Delta n$	Corrected mean motion
$M_k = M_0 + nt_k$	Computed mean anomaly
$M_k = E_k - e \sin E_k$	Kepler's Equation for Eccentric anomaly solved by iteration (radians)
$\begin{cases} \sin v_k = \frac{\sqrt{1-e^2} \sin E_k}{1-e \cos E_k} \\ \cos v_k = \frac{\cos E_k - e}{1-e \cos E_k} \end{cases}$	Computed true anomaly
$\phi_k = v_k + \omega$	Computed argument of latitude
$\begin{cases} \delta u_k = C_{us} \sin(2\phi_k) + C_{uc} \cos(2\phi_k) \\ \delta r_k = C_{rs} \sin(2\phi_k) + C_{rc} \cos(2\phi_k) \\ \delta i_k = C_{is} \sin(2\phi_k) + C_{ic} \cos(2\phi_k) \end{cases}$	Argument of latitude correction Radius correction Inclination correction
$u_k = \phi_k + \delta u_k$	Corrected Argument of latitude parameters
$r_k = A(1 - e \cos E_k) + \delta r_k$	Corrected radius
$i_k = i_0 + \text{IDOT} \cdot t_k + \delta i_k$	Corrected inclination
$\begin{cases} x_k = r_k \cos u_k \\ y_k = r_k \sin u_k \end{cases}$	Computed satellite positions in orbital plane
$\Omega_k = \Omega_0 + (\dot{\Omega} - \dot{\Omega}_e) t_k - \dot{\Omega}_e t_{oe}$ $\begin{cases} X_k = x_k \cos \Omega_k - y_k \cos i_k \sin \Omega_k \\ Y_k = x_k \sin \Omega_k + y_k \cos i_k \cos \Omega_k \\ Z_k = y_k \sin i_k \end{cases}$	Corrected longitude of ascending node in CGCS2000; MEO/IGSO satellite coordinates in CGCS2000

Computation	Description
$\Omega_k = \Omega_0 + \dot{\Omega}t_k - \dot{\Omega}_e t_{oe}$ $\begin{cases} X_{GK} = x_k \cos\Omega_k - y_k \cos i_k \sin\Omega_k \\ Y_{GK} = x_k \sin\Omega_k + y_k \cos i_k \cos\Omega_k \\ Z_{GK} = y_k \sin i_k \end{cases}$ $\begin{bmatrix} X_k \\ Y_k \\ Z_k \end{bmatrix} = R_Z(\dot{\Omega}_e t_k) R_X(-5^\circ) \begin{bmatrix} X_{GK} \\ Y_{GK} \\ Z_{GK} \end{bmatrix}$ <p>Where,</p> $R_X(\varphi) = \begin{pmatrix} 1 & 0 & 0 \\ 0 & +\cos\varphi & +\sin\varphi \\ 0 & -\sin\varphi & +\cos\varphi \end{pmatrix}$ $R_Z(\varphi) = \begin{pmatrix} +\cos\varphi & +\sin\varphi & 0 \\ -\sin\varphi & +\cos\varphi & 0 \\ 0 & 0 & 1 \end{pmatrix}$	<p>Corrected longitude of ascending node in inertial coordinate system;</p> <p>GEO satellite coordinates in user-defined inertial system;</p> <p>GEO satellite coordinates in CGCS2000</p>
<p>* In the equations, “t” is the time of signal transmission in BDT. “t<sub>k</sub>” is the total time difference between t and ephemeris reference time t<sub>oe</sub> after taking account of beginning or end of a week crossovers. That is, subtract 604800 seconds from t<sub>k</sub> if t<sub>k</sub> is greater than 302400, add 604800 seconds to t<sub>k</sub> if t<sub>k</sub> is less than -302400 seconds.</p>	

#### 5.2.4.13 Page number (Pnum)

The bits 44 through 50, 7 bits altogether of subframe 4 and subframe 5 are for page numbers (Pnum). subframe 4 and subframe 5 are subcommutated 24 times via pages 1 through 24. Pnum identifies the page number of the subframe.

The almanac information of SV ID 1 through 24 is arranged in pages 1 through 24 of subframe 4. The almanac information of SV ID 25 through 30 is arranged in pages 1 through 6 of subframe 5. The page number corresponds to the SV ID one by one.

#### 5.2.4.14 Almanac Parameters ( t<sub>0a</sub>, √A, e, ω, M<sub>0</sub>, Ω<sub>0</sub>, Ω̇, δ<sub>i</sub>, a<sub>0</sub>, a<sub>1</sub> )

Almanac parameters are updated within every 7 days.

Definitions, characteristics and user algorithms of almanac parameters are listed in Tables 5-12, 5-13 and 5-14 respectively.

**Tab 5-12 Almanac parameters definitions**

Parameter	Definition
$t_{oa}$	Almanac reference time
$\sqrt{A}$	Square root of semi-major axis
$e$	Eccentricity
$\omega$	Argument of Perigee
$M_0$	Mean anomaly at reference time
$\Omega_0$	Longitude of ascending node of orbital plane computed according to reference time
$\dot{\Omega}$	Rate of right ascension
$\delta_i$	Correction of orbit reference inclination at reference time
$a_0$	Satellite clock bias
$a_1$	Satellite clock rate

**Tab 5-13 Almanac parameters characteristics**

Parameter	No. of Bits	Scale factor (LSB)	Effective range	Units
$t_{oa}$	8	$2^{12}$	602112	s
$\sqrt{A}$	24	$2^{-11}$	8192	$m^{1/2}$
$e$	17	$2^{-21}$	0.0625	—
$\omega$	24*	$2^{-23}$	$\pm 1$	$\pi$
$M_0$	24*	$2^{-23}$	$\pm 1$	$\pi$
$\Omega_0$	24*	$2^{-23}$	$\pm 1$	$\pi$
$\dot{\Omega}$	17*	$2^{-38}$	—	$\pi/s$
$\delta_i$	16*	$2^{-19}$	—	$\pi$
$a_0$	11*	$2^{-20}$	—	s
$a_1$	11*	$2^{-38}$	—	s/s

\* Parameters so indicated are two's complement, with the sign bit (+ or -) occupying the MSB.

Tab 5-14 Almanac algorithms for users

Computation	Description
$\mu = 3.986004418 \times 10^{14} \text{ m}^3/\text{s}^2$	Earth's universal gravitational constant of CGCS2000
$\dot{\Omega}_e = 7.2921150 \times 10^{-5} \text{ rad/s}$	Value of the earth's rotation rate of CGCS2000
$A = (\sqrt{A})^2$	Computed semi-major axis
$n_0 = \sqrt{\frac{\mu}{A^3}}$	Computed mean motion (rad/sec)
$t_k = t - t_{\text{oa}}^*$	Computed time from Almanac reference time
$M_k = M_0 + n_0 t_k$	Computed mean anomaly
$M_k = E_k - e \sin E_k$	Kepler's equation for eccentric anomaly by iteration (radians)
$\begin{cases} \sin v_k = \frac{\sqrt{1-e^2} \sin E_k}{1-e \cos E_k} \\ \cos v_k = \frac{\cos E_k - e}{1-e \cos E_k} \end{cases}$	Computed true anomaly
$\phi_k = v_k + \omega$	Computed argument of latitude
$r_k = A(1 - e \cos E_k)$	Corrected radius
$\begin{cases} x_k = r_k \cos \phi_k \\ y_k = r_k \sin \phi_k \end{cases}$	Computed satellite positions in orbital plane
$\Omega_k = \Omega_0 + (\dot{\Omega} - \dot{\Omega}_e)t_k - \dot{\Omega}_e t_{\text{oa}}$	Corrected longitude of ascending node in CGCS2000
$i = i_0 + \delta_i^{**}$	Orbit inclination at reference time
$\begin{cases} X_k = x_k \cos \Omega_k - y_k \cos i \sin \Omega_k \\ Y_k = x_k \sin \Omega_k + y_k \cos i \cos \Omega_k \\ Z_k = y_k \sin i \end{cases}$	Computed GEO/MEO/IGSO satellite coordinates in CGCS2000
<p>* In the equations, "t" is the time of signal transmission in BDT. "t<sub>k</sub>" is the total time offset between time t and Almanac reference time t<sub>oa</sub> taking account of beginning or end of a week crossover. That is, subtract 604800 seconds from t<sub>k</sub> if t<sub>k</sub> is greater than 302400, add 604800 seconds to t<sub>k</sub> if t<sub>k</sub> is less than -302400.</p> <p>** For MEO/IGSO satellites, i<sub>0</sub>=0.30 semi-circles; for GEO satellites, i<sub>0</sub>=0.00.</p>	



Almanac time computation is as follows:

$$t = t_{sv} - \Delta t_{sv}$$

where

$t$  is BDT in seconds at time of signal transmission;

$t_{sv}$  is the effective satellite ranging code phase time in seconds at time of signal transmission;

$\Delta t_{sv}$  is the offset of satellite ranging code phase time in seconds and is given by the equation:

$$\Delta t_{sv} = a_0 + a_1(t - t_{oa})$$

Where  $t$  can be replaced by  $t_{sv}$  regardless of its sensitivity. The almanac reference time  $t_{oa}$  is counted from the starting time of almanac week number ( $WN_a$ ).

#### 5.2.4.15 Almanac Week Number ( $WN_a$ )

Almanac week number ( $WN_a$ ) of 8 bits is the BDT integer week count (Modulo 256) with effective range of 0 to 255.

#### 5.2.4.16 Satellite Health Information ( $Hea_i$ , $i=1\sim30$ )

The satellite health information ( $Hea_i$ ) occupies 9 bits. The 9<sup>th</sup> bit indicates the satellite clock health flag, while the 8<sup>th</sup> bit indicates the B1I signal health status and the 2<sup>th</sup> bit indicates the information health status. The definitions are in Table 5-15.

Tab 5-15 Satellite health information definitions

Bit allocation	Information code	Health information definition
Bit 9 (MSB)	0	Satellite clock OK
	1	*
Bit 8	0	B1I Signal OK
	1	B1I Signal Weak**
Bit 7~3	0	Reserved
	1	Reserved
Bit 2	0	NAV Message OK
	1	NAV Message Bad (IOD over limit)
Bit 1 (LSB)	0	Reserved
	1	Reserved

\* the satellite clock is unavailable if the other 8 bits are all “0”; the satellite is in failure or permanently shut off if the last 8bits are all “1”; the definition is reserved if the other 8 bits are in other values.

\*\* The signal power is 10 dB lower than nominal value.

#### 5.2.4.17 Time Parameters relative to UTC ( $A_{0UTC}$ , $A_{1UTC}$ , $\Delta t_{LS}$ , $WN_{LSF}$ , $DN$ , $\Delta t_{LSF}$ )

These parameters indicate the relationship between BDT and UTC. Definition of the parameters are listed in Table 5-16.

Tab 5-16 Parameters relative to UTC

Parameter	No. of bits	Scale factor(LSB)	Effective range	Units
$A_{0UTC}$	$32^*$	$2^{-30}$	—	s
$A_{1UTC}$	$24^*$	$2^{-50}$	—	s/s
$\Delta t_{LS}$	$8^*$	1	—	s
$WN_{LSF}$	8	1	—	week
DN	8	1	6	day
$\Delta t_{LSF}$	$8^*$	1	—	s

\* Parameters so indicated are two’s complement, with the sign bit (+ or -) occupying the MSB.

$A_{0UTC}$ : BDT clock bias relative to UTC;

$A_{UTC}$ : BDT clock rate relative to UTC;

$\Delta t_{LS}$ : Delta time due to leap seconds before the new leap second effective;

$WN_{LSF}$ : Week number of the new leap second;

DN: Day number of week of the new leap second;

$\Delta t_{LSF}$ : Delta time due to leap seconds after the new leap second effective;

Conversion from BDT into UTC:

The broadcast UTC parameters, the  $WN_{LSF}$  and DN values make users compute UTC with error not greater than 1 microsecond.

Depending upon the relationship of the effectivity time of leap second event and user's current BDT, the following three different cases of UTC/BDT conversion exist.

1) Whenever the effectivity time indicated by the  $WN_{LSF}$  and the DN values is not in the past (relative to the user's present time), and the user's current time  $t_E$  is prior to  $DN+2/3$ , the UTC/BDT relationship is given by:

$$t_{UTC} = (t_E - \Delta t_{UTC})[\text{modulo } 86400], \text{ seconds}$$

$$\Delta t_{UTC} = \Delta t_{LS} + A_{0UTC} + A_{1UTC} \times t_E, \text{ seconds}$$

Where,  $t_E$ : SOW computed by users in BDT.

2) Whenever the user's current time  $t_E$  falls within the time span of  $DN+2/3$  to  $DN+5/4$ , proper accommodation of leap second event with possible week number transition is provided by the following equation for UTC:

$$t_{UTC} = W[\text{modulo}(86400 + \Delta t_{LSF} - \Delta t_{LS})], \text{ seconds}$$

where,

$$W = (t_E - \Delta t_{UTC} - 43200)[\text{modulo } 86400] + 43200, \text{ seconds}$$

$$\Delta t_{UTC} = \Delta t_{LS} + A_{0OUT} + A_{1UTC} \times t_E, \text{ seconds}$$

3) Whenever the effectivity time of leap second event, as indicated

by the  $WN_{LSF}$  and DN values, is in the past (relative to the user's current time), and the user's current time  $t_E$  is after  $DN+5/4$ , the UTC/BDT relationship is given by:

$$t_{UTC} = (t_E - \Delta t_{UTC})[\text{modulo } 86400], \text{ seconds}$$

$$\Delta t_{UTC} = \Delta t_{LSF} + A_{0UTC} + A_{1UTC} \times t_E, \text{ seconds}$$

The parameter definitions are the same with those in case 1).

#### 5.2.4.18 Time Parameters relative to GPS time ( $A_{0GPS}$ , $A_{1GPS}$ )

These parameters indicate the relationship between BDT and GPS time as in Table 5-17. (Not broadcast temporarily)

**Tab 5-17 Time parameters relative to GPS time**

Parameter	No. of Bits	Scale factor (LSB)	Units
$A_{0GPS}$	14*	0.1	ns
$A_{1GPS}$	16*	0.1	ns/s
* Parameters so indicated are two's complement, with the sign bit (+ or -) occupying the MSB.			

$A_{0GPS}$ : BDT clock bias relative to GPS time;

$A_{1GPS}$ : BDT clock rate relative to GPS time.

The relationship between BDT and GPS time is as follows:

$$t_{GPS} = t_E - \Delta t_{GPS}$$

where  $\Delta t_{GPS} = A_{0GPS} + A_{1GPS} \times t_E$ ;

$t_E$  is SOW in BDT computed by user.

#### 5.2.4.19 Time Parameters relative to Galileo time( $A_{0Gal}$ , $A_{1Gal}$ )

These parameters indicate the relationship between BDT and Galileo time as in Table 5-18. (Not broadcast temporarily)

**Tab 5-18 Time parameters relative to Galileo time**

Parameter	No. of Bits	Scale factor (LSB)	Units
$A_{0Gal}$	14*	0.1	ns
$A_{1Gal}$	16*	0.1	ns/s

\* Parameters so indicated are two's complement, with the sign bit (+ or -) occupying the MSB.

$A_{0Gal}$ : BDT clock bias relative to Galileo system time;

$A_{1Gal}$ : BDT clock rate relative to Galileo system time.

Relationship between BDT and Galileo system time is as follows:

$$t_{Gal} = t_E - \Delta t_{Gal}$$

where  $\Delta t_{Gal} = A_{0Gal} + A_{1Gal} \times t_E$ ;

$t_E$  is user computed SOW in BDT.

#### 5.2.4.20 Time Parameters relative to GLONASS time ( $A_{0GLO}$ , $A_{1GLO}$ )

These parameters indicate the relationship between BDT and GLONASS time as in Table 5-19. (Not broadcast temporarily)

**Tab 5-19 Time parameters relative to GLONASS time**

Parameter	No. of Bits	Scale factor (LSB)	Units
$A_{0GLO}$	14*	0.1	ns
$A_{1GLO}$	16*	0.1	ns/s

\* Parameters so indicated are two's complement, with the sign bit (+ or -) occupying the MSB.

$A_{0GLO}$ : BDT clock bias relative to GLONASS time;

$A_{1GLO}$ : BDT clock rate relative to GLONASS time.

Relationship between BDT and Glonass time is as follows:

$$t_{GLO} = t_E - \Delta t_{GLO}$$

where  $\Delta t_{GLO} = A_{0GLO} + A_{1GLO} \times t_E$ ;

$t_E$  is user computed SOW in BDT.

## 5.3 D2 NAV Message

### 5.3.1 D2 NAV Message Frame Structure

The NAV message in format D2 is structured with superframe, frame and subframe. Every superframe is 180000 bits long, lasting 6 minutes. Every superframe is composed of 120 frames each with 1500 bits and lasting 3 seconds. Every frame is composed of 5 subframes, each with 300 bits and lasting 0.6 second. Every subframe is composed of 10 words, each with 30 bits and lasting 0.06 second.

Every word is composed of NAV message data and parity bits. The first 15 bits in word 1 of every subframe is not encoded, and the last 11 bits is encoded in BCH(15,11,1) for error correction. For the other 9 words of the subframe both BCH(15,11,1) encoding and interleaving are involved. Thus there are 22 information bits and 8 parity bits in each word. See Figure 5-12 for the detailed structure.

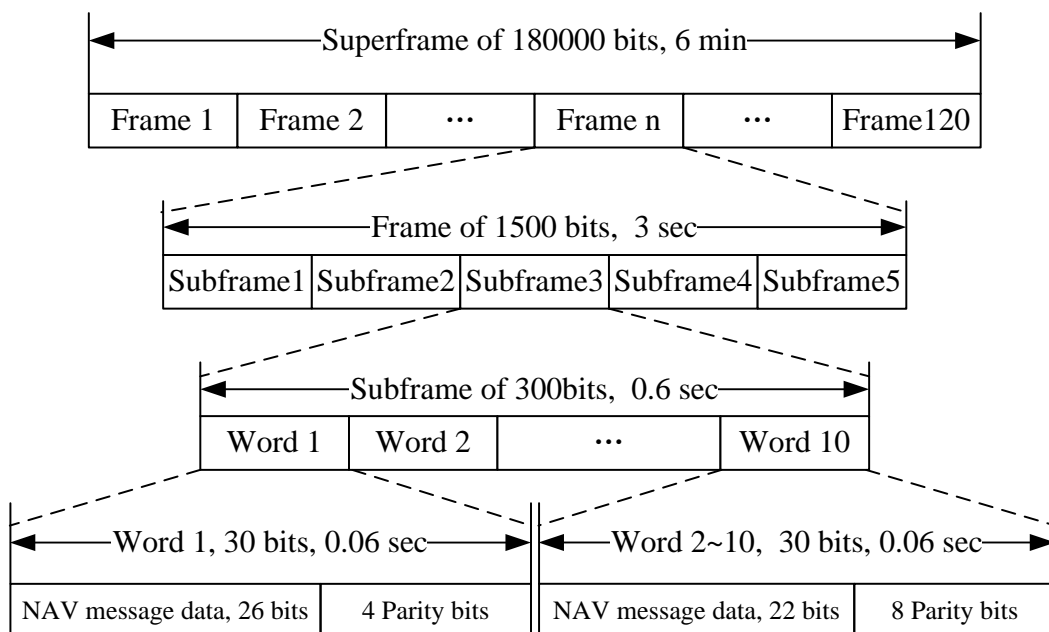

**Fig 5-12 Structure of NAV message in format D2**

### 5.3.2 D2 NAV Message Detailed structure

Information in format D2 includes: the basic NAV information of the broadcasting satellite, almanac, time offset from other systems, integrity and differential correction information of BDS and ionospheric grid information as shown in Figure 5-13. The subframe 1 shall be subcommutated 10 times via 10 pages. The subframe 2, subframe 3 and subframe 4 shall be subcommutated 6 times each via 6 pages. The subframe 5 shall be subcommutated 120 times via 120 pages.

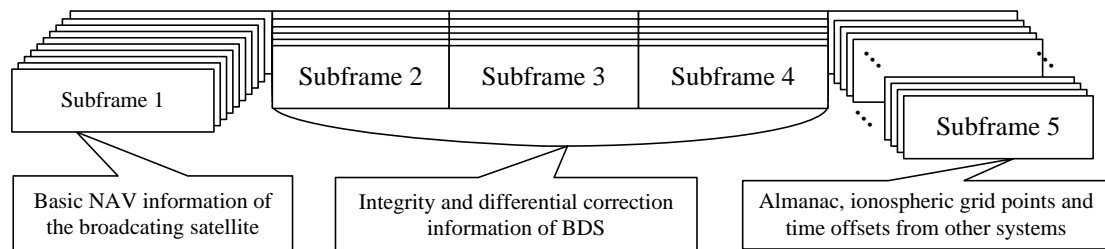

**Fig 5-13 Frame structure and information contents of NAV message in format D2**

The bit allocation of each subframe in format D2 is shown in Figures 5-14 through 5-18. The 150 LSBs of pages 1 through 10 in subframe 1, pages 1 through 6 of subframe 4, pages 14 through 34, pages 74 through 94 pages and 103 through 120 of subframe 5 in format D2 are to be reserved.

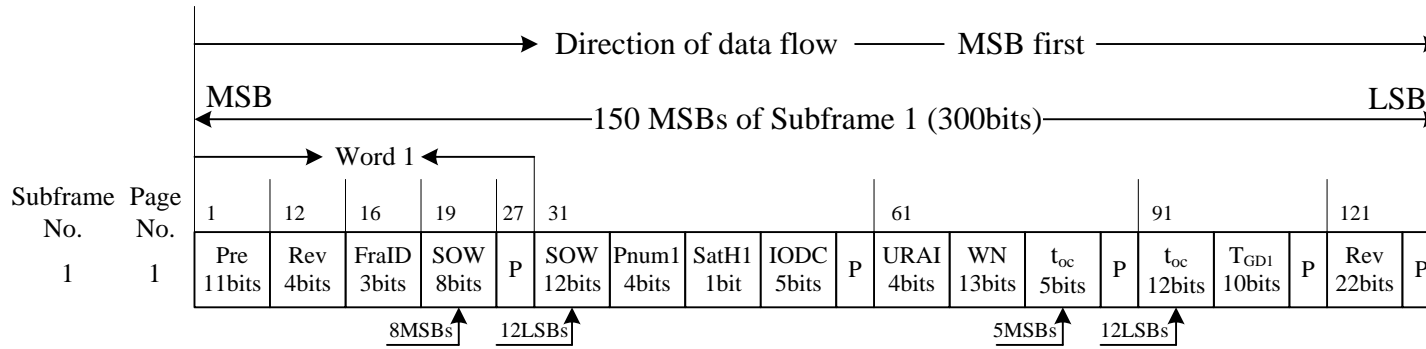

Fig 5-14-1 Bits allocation of 150 MSBs of page 1 in subframe 1 of format D2

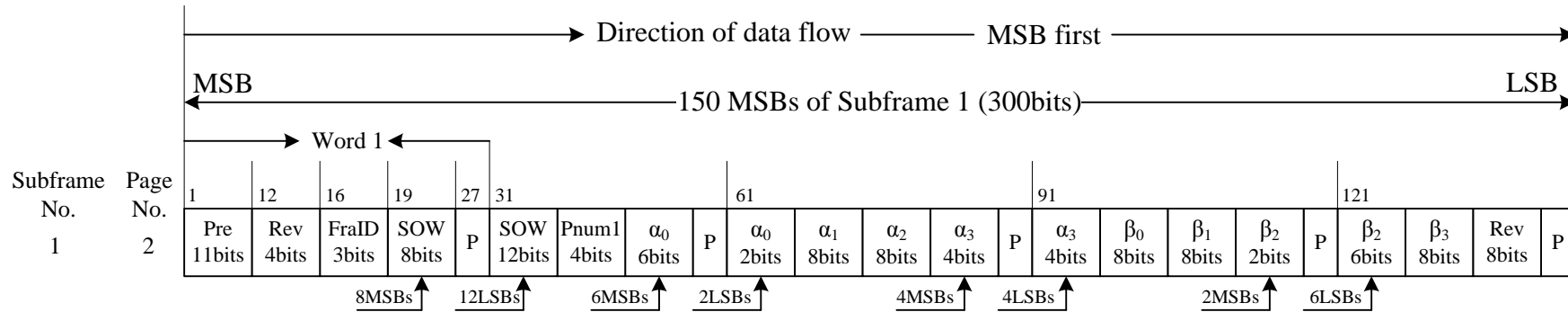
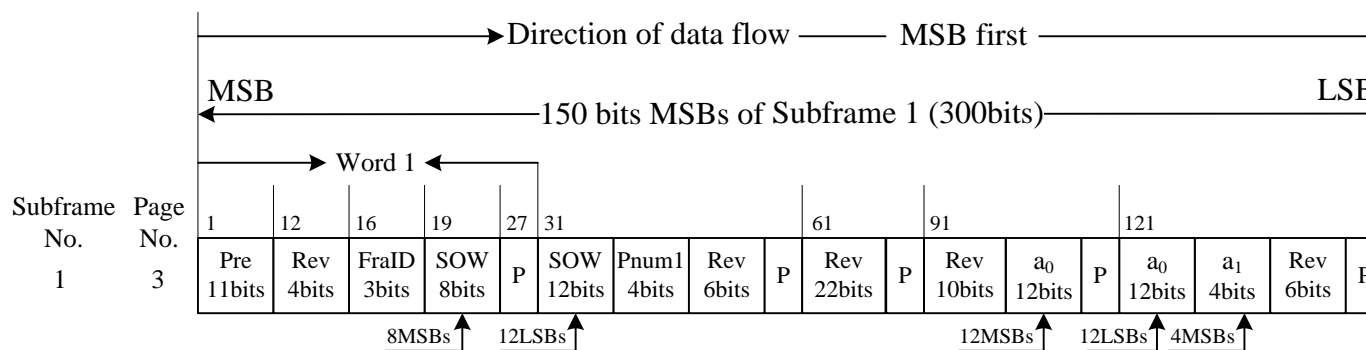
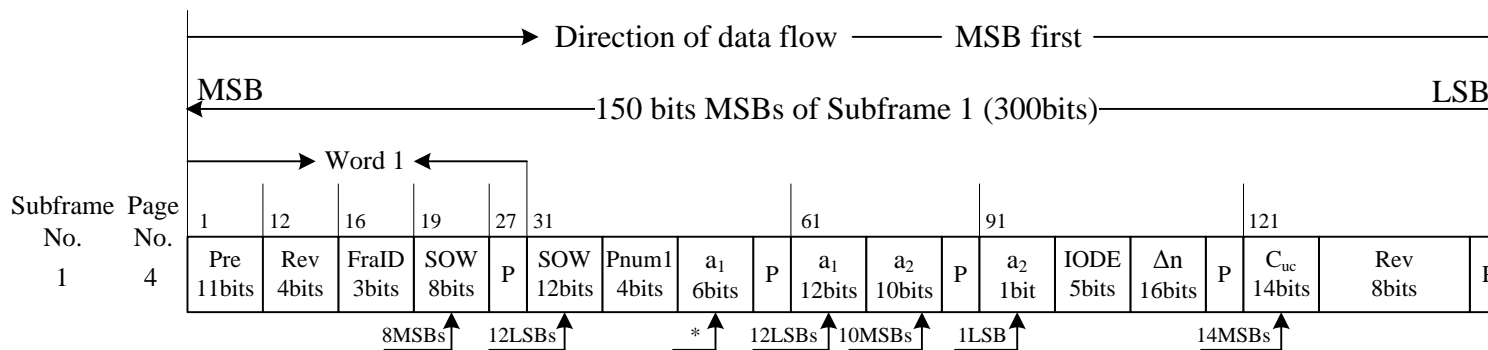

Fig 5-14-2 Bits allocation of 150 MSBs of page 2 in subframe 1 of format D2



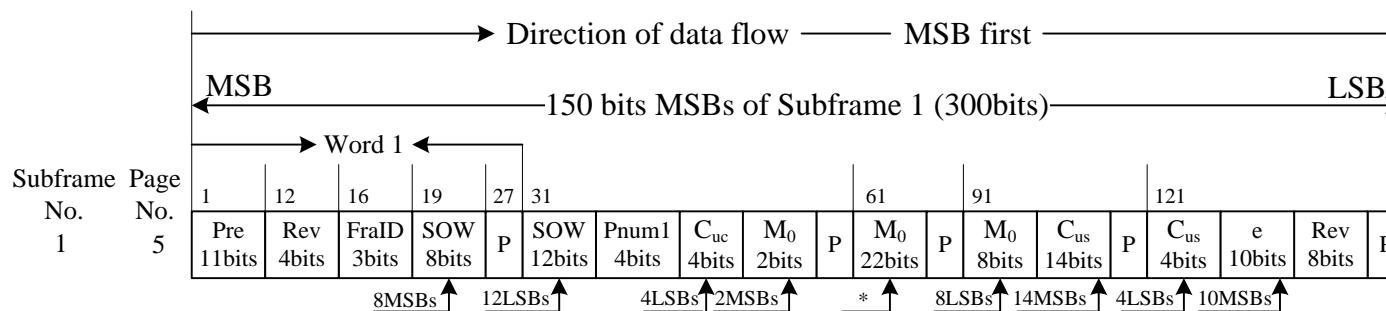

**Fig 5-14-3 Bits allocation of 150 MSBs of page 3 in subframe 1 of format D2**



\* These are data bits next to MSBs and before LSBs.

**Fig 5-14-4 Bits allocation of 150 MSBs of page 4 in subframe 1 of format D2**



\* These are data bits next to MSBs and before LSBs.

**Fig 5-14-5 Bits allocation of 150 MSBs of page 5 in subframe 1 of format D2**

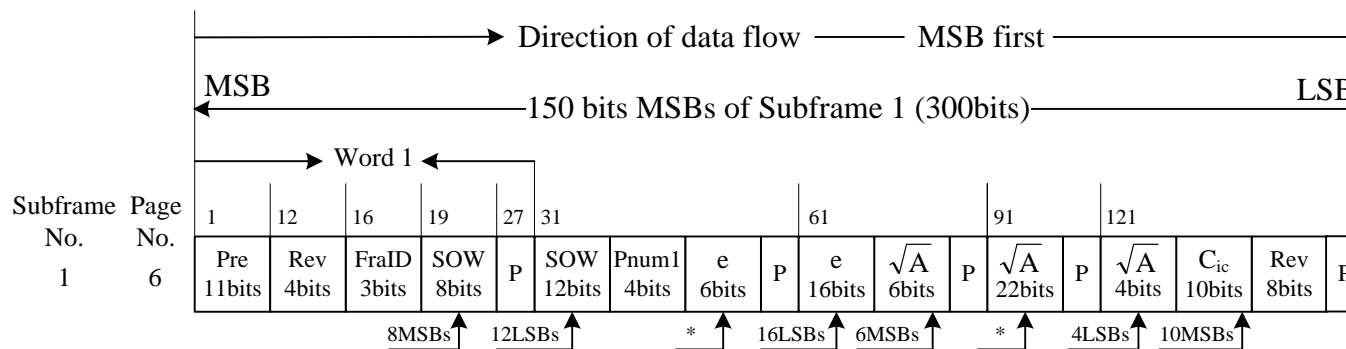

\* These are data bits next to MSBs and before LSBs.

**Fig 5-14-6 Bits allocation of 150 MSBs of page 6 in subframe 1 of format D2**

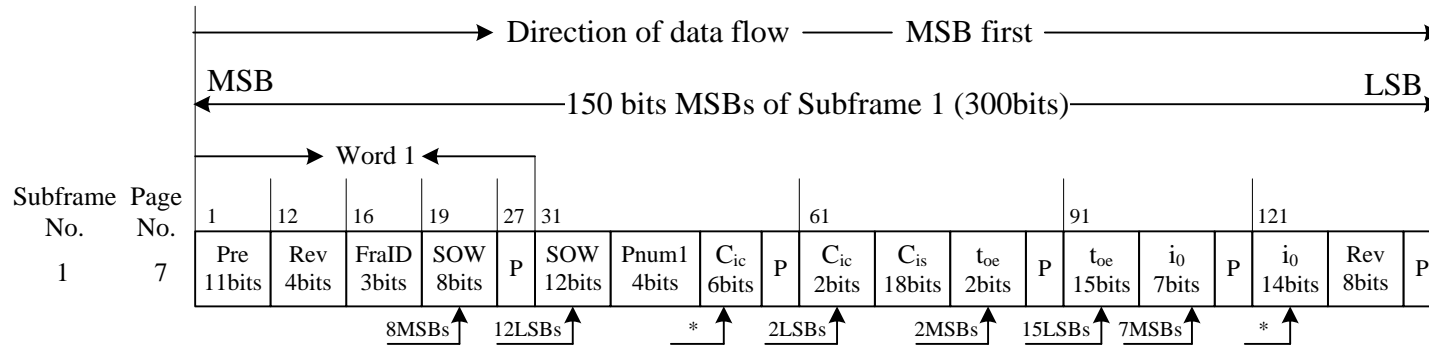

\* These are data bits next to MSBs and before LSBs.

**Fig 5-14-7 Bits allocation of 150 MSBs of page 7 in subframe 1 of format D2**

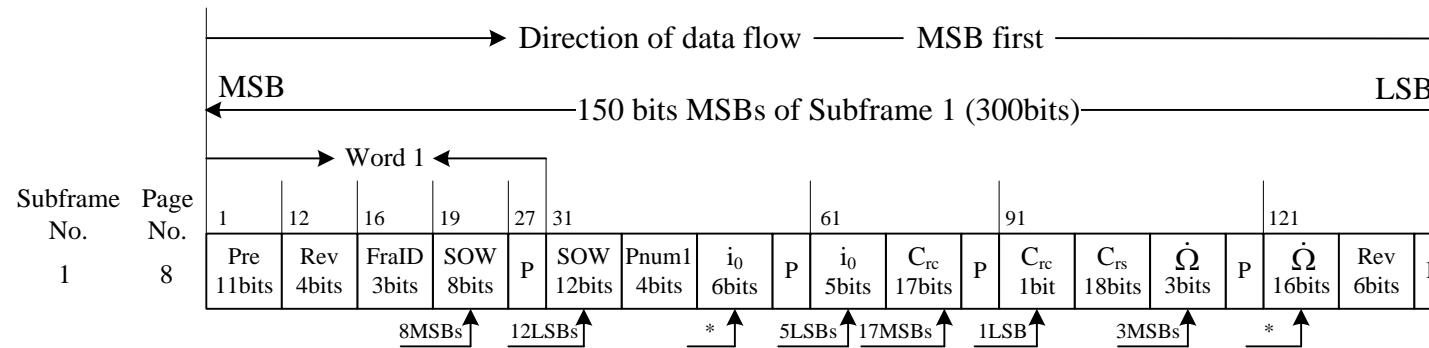

\* These are data bits next to MSBs and before LSBs.

**Fig 5-14-8 Bits allocation of 150 MSBs of page 8 in subframe 1 of format D2**

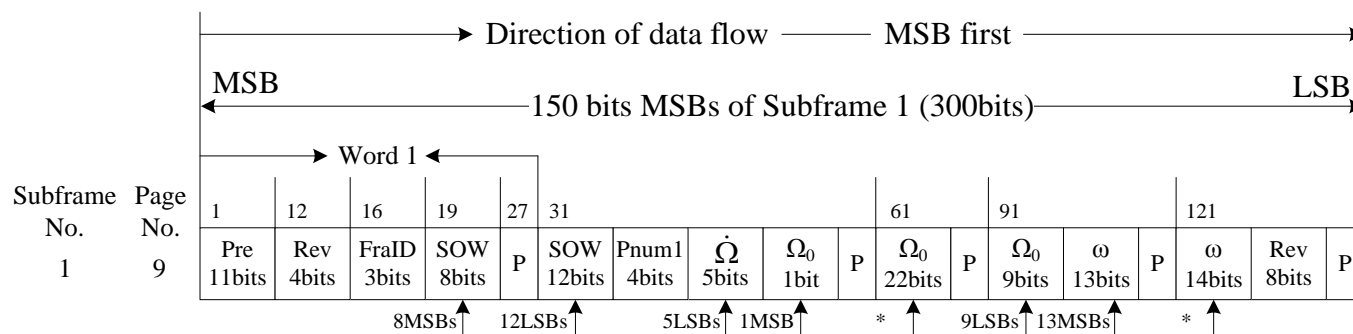

\* These are data bits next to MSBs and before LSBs.

**Fig 5-14-9 Bits allocation of 150 MSBs of page 9 in subframe 1 of format D2**

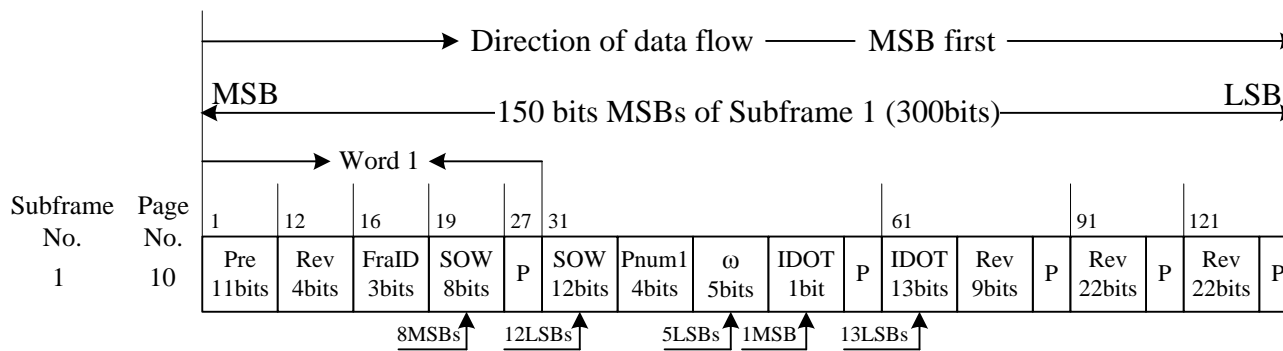

**Fig 5-14-10 Bits allocation of 150 MSBs of page 10 in subframe 1 of format D2**

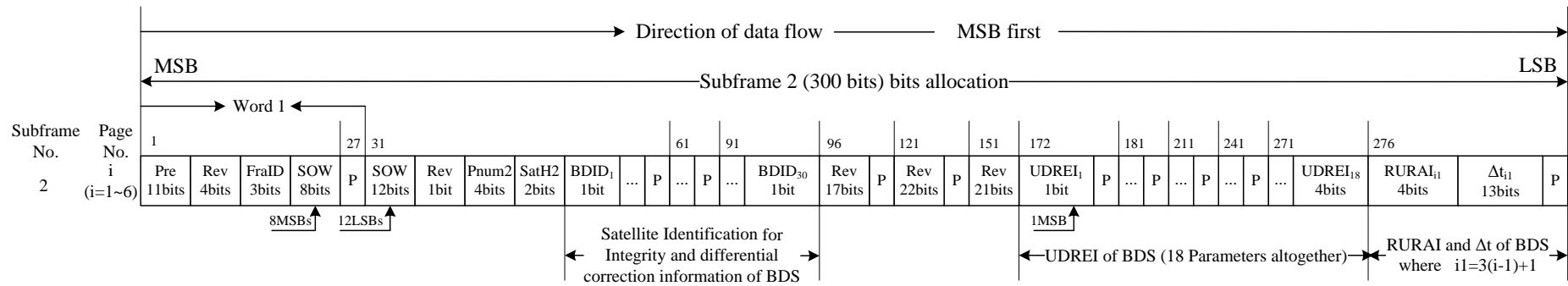

Fig 5-15 Bits allocation of subframe 2 of format D2

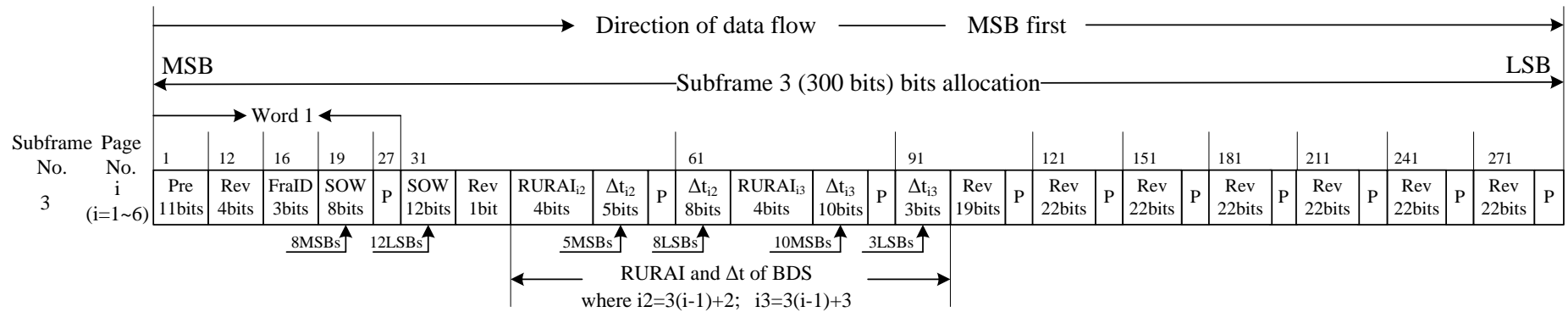

Fig 5-16 Bits allocation of subframe 3 of format D2

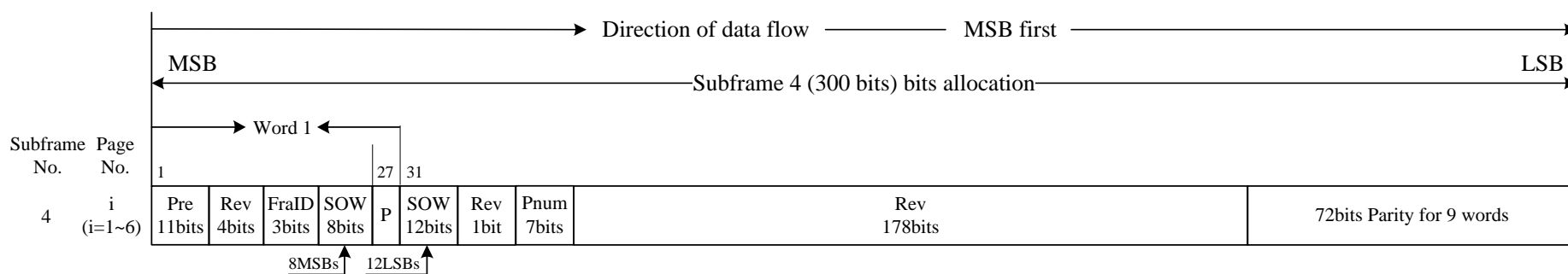

Fig 5-17 Bits allocation of subframe 4 of format D2

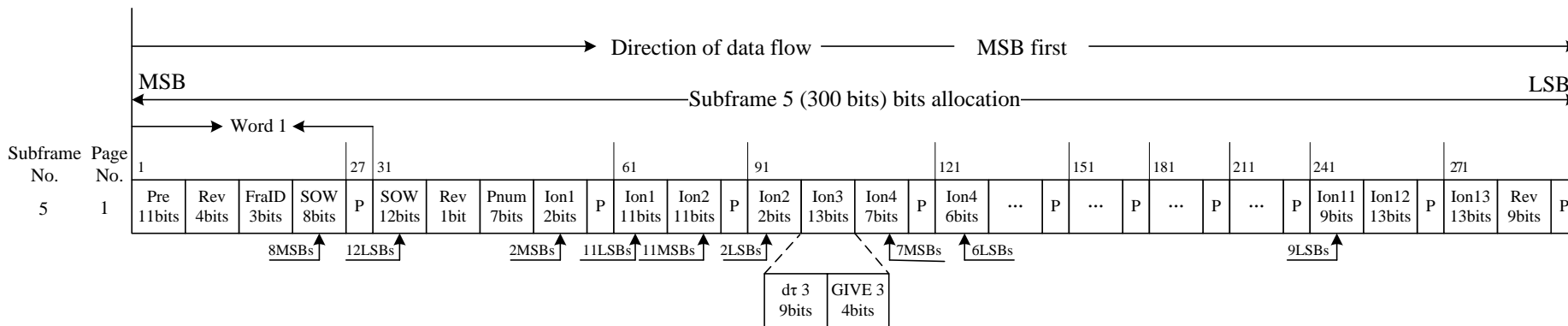

Fig 5-18-1 Bits allocation of page 1 of subframe 5 in format D2

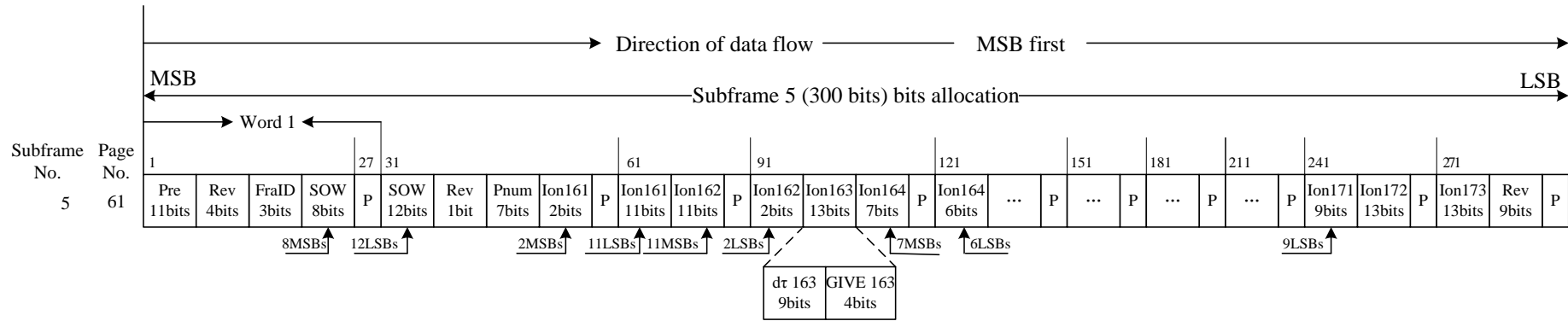

Fig 4-18-2 Bits allocation of page 61 of subframe 5 in format D2

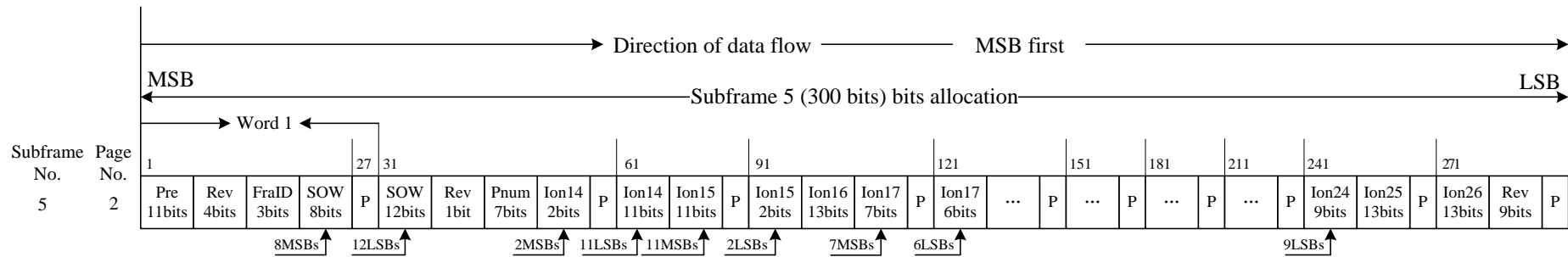

Fig 5-18-3 Bits allocation of page 2 of subframe 5 in format D2

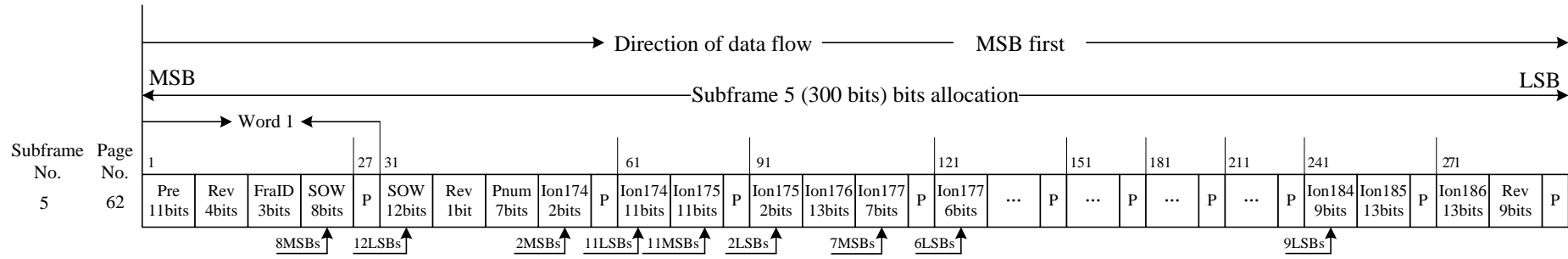

Fig 5-18-4 Bits allocation of page 62 of subframe 5 in format D2

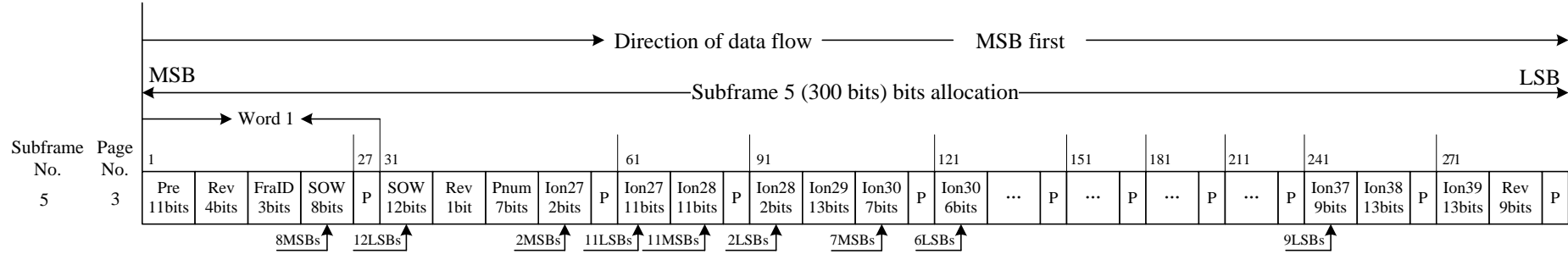

Fig 5-18-5 Bits allocation of page 3 of subframe 5 in format D2



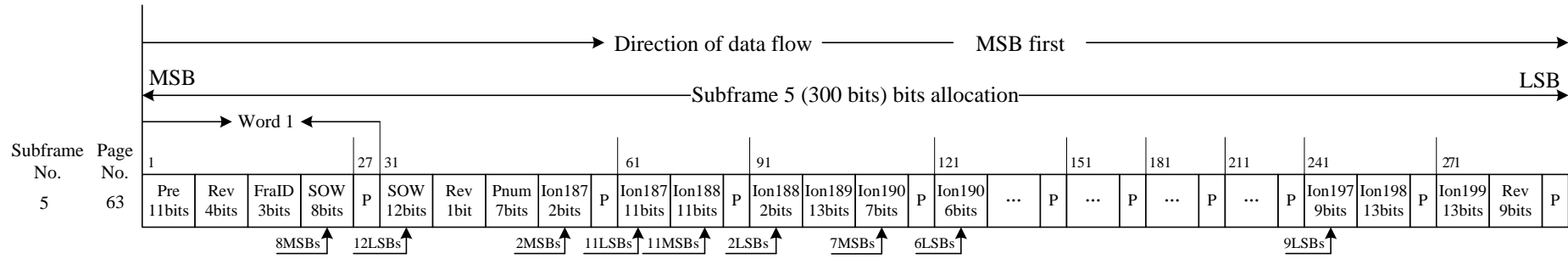

Fig 5-18-6 Bits allocation of page 63 of subframe 5 in format D2

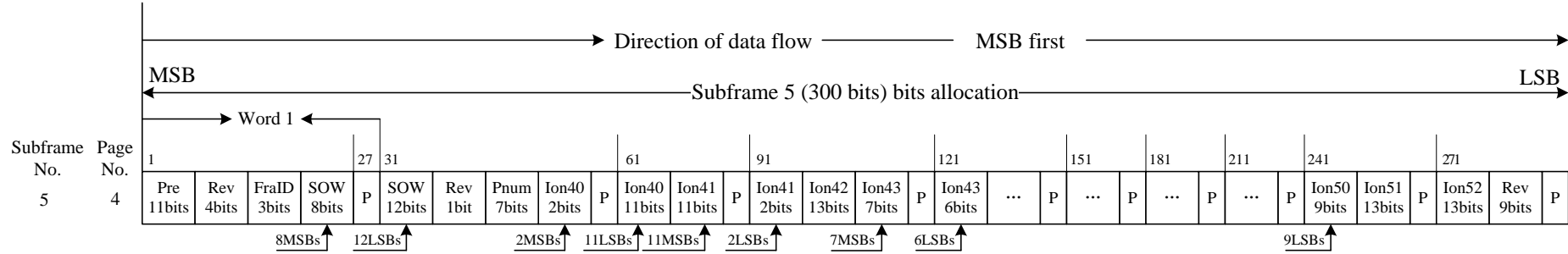

Fig 5-18-7 Bits allocation of page 4 of subframe 5 in format D2

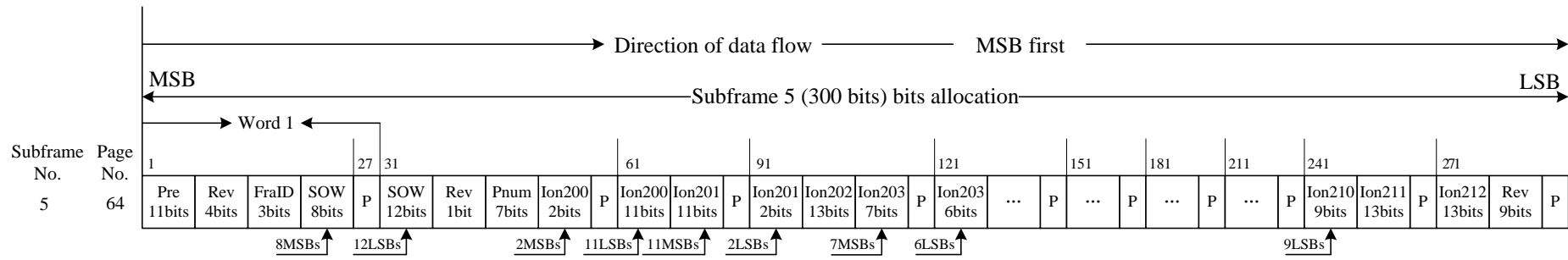

Fig 5-18-8 Bits allocation of page 64 of subframe 5 in format D2

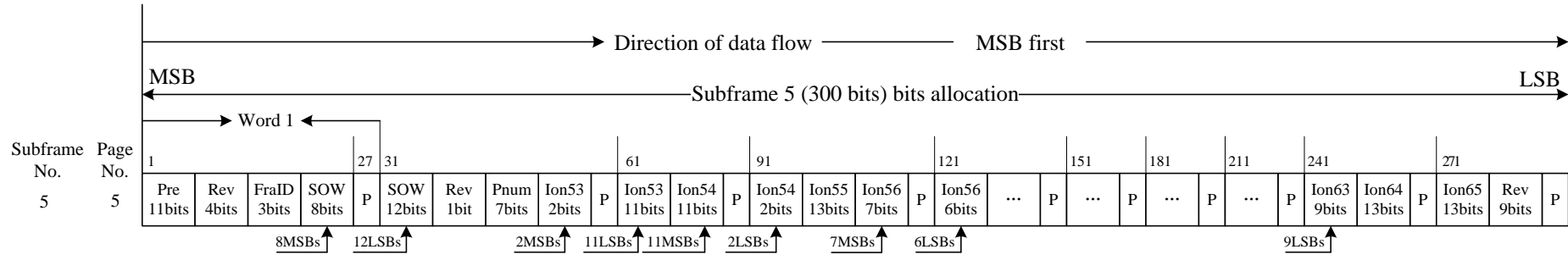

Fig 5-18-9 Bits allocation of page 5 of subframe 5 in format D2

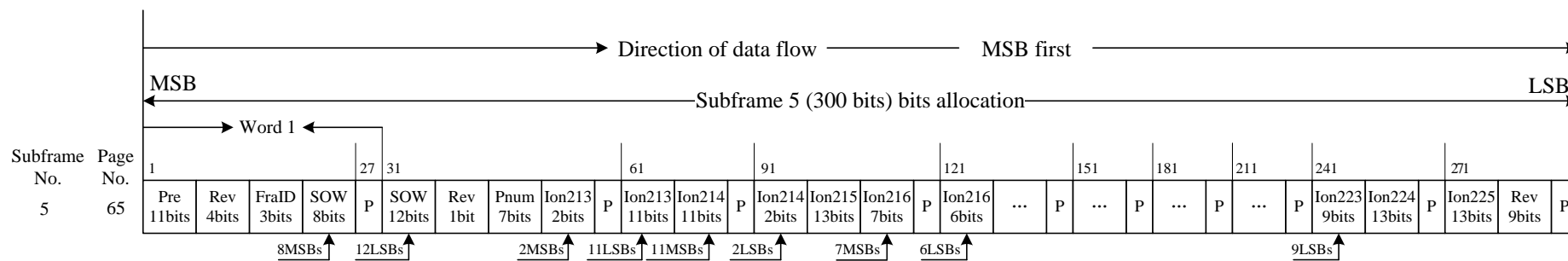

Fig 5-18-10 Bits allocation of page 65 of subframe 5 in format D2

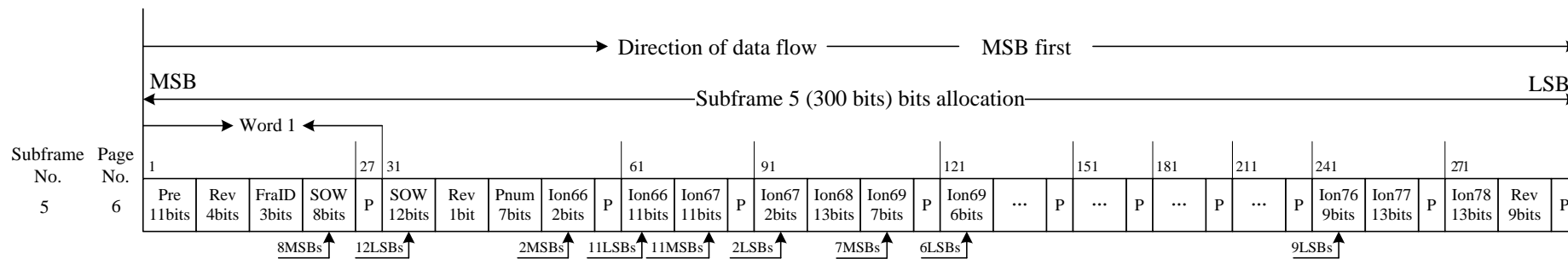

Fig 5-18-11 Bits allocation of page 6 of subframe 5 in format D2

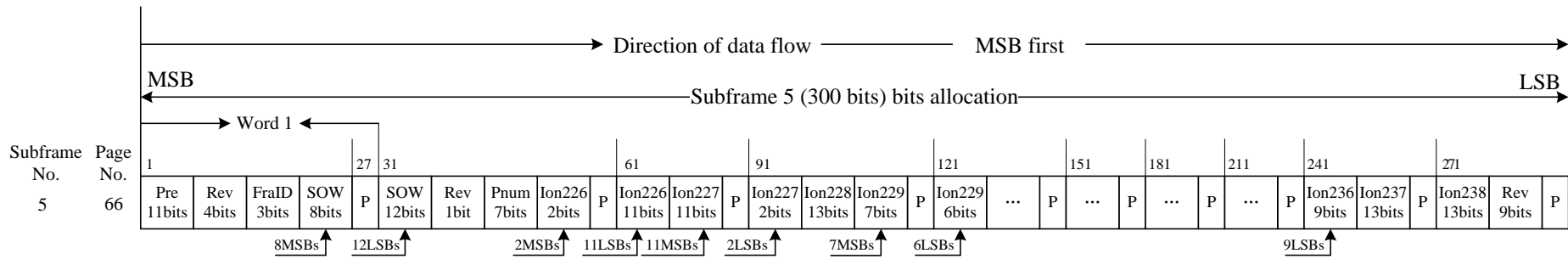

Fig 5-18-12 Bits allocation of page 66 of subframe 5 in format D2

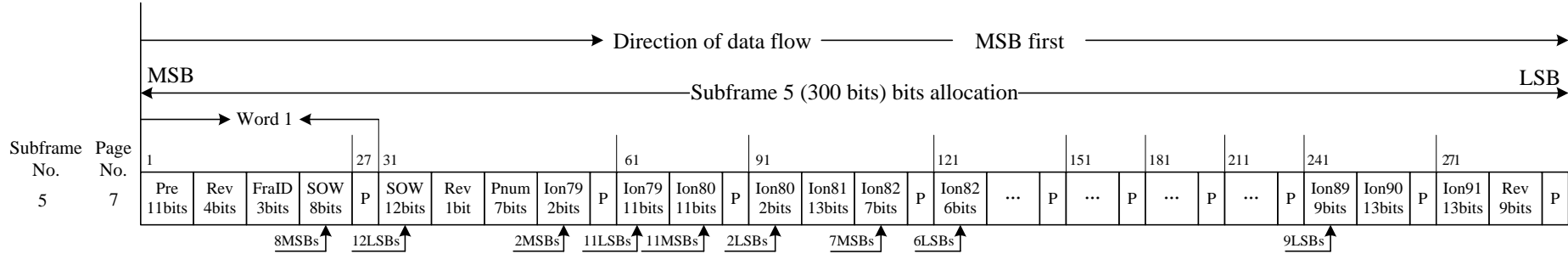

Fig 5-18-13 Bits allocation of page 7 of subframe 5 in format D2

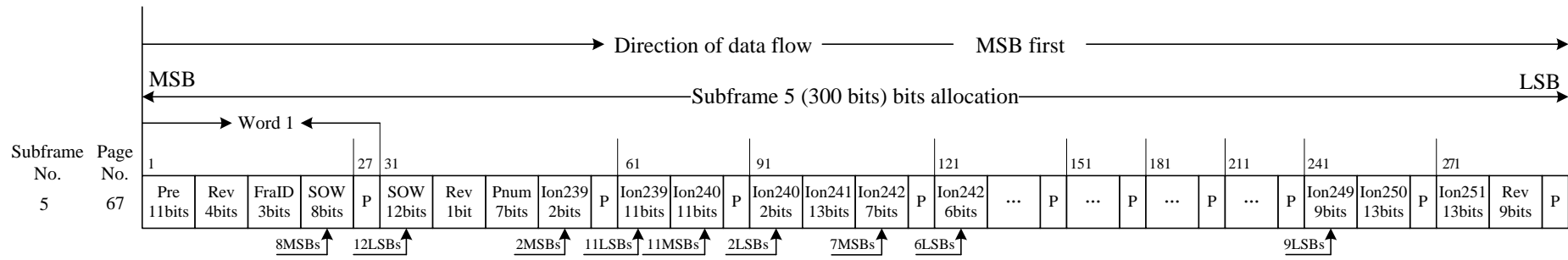

Fig 5-18-14 Bits allocation of page 67 of subframe 5 in format D2

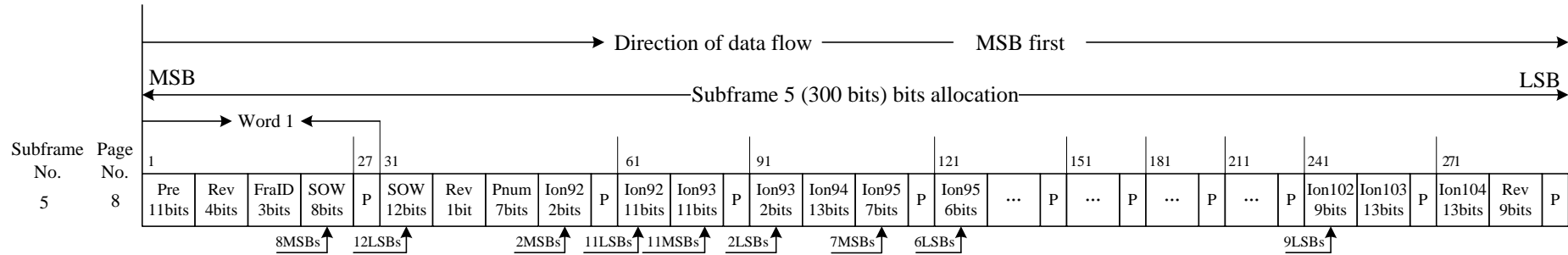

Fig 5-18-15 Bits allocation of page 8 of subframe 5 in format D2

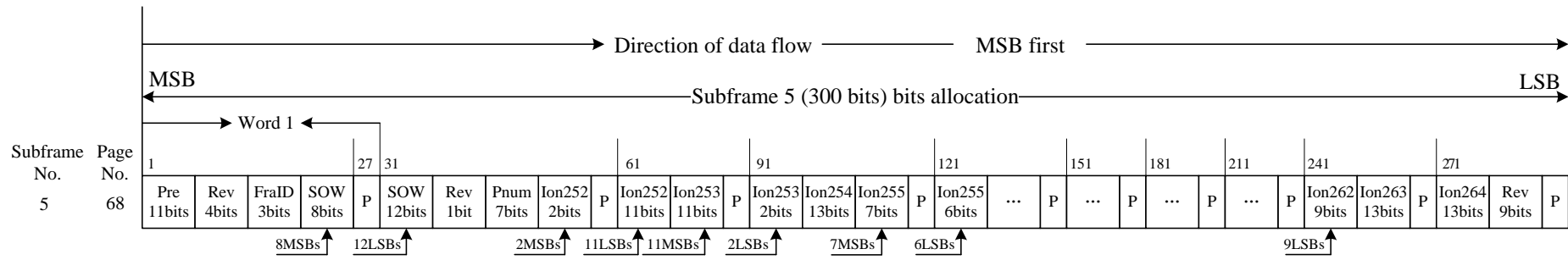

Fig 5-18-16 Bits allocation of page 68 of subframe 5 in format D2

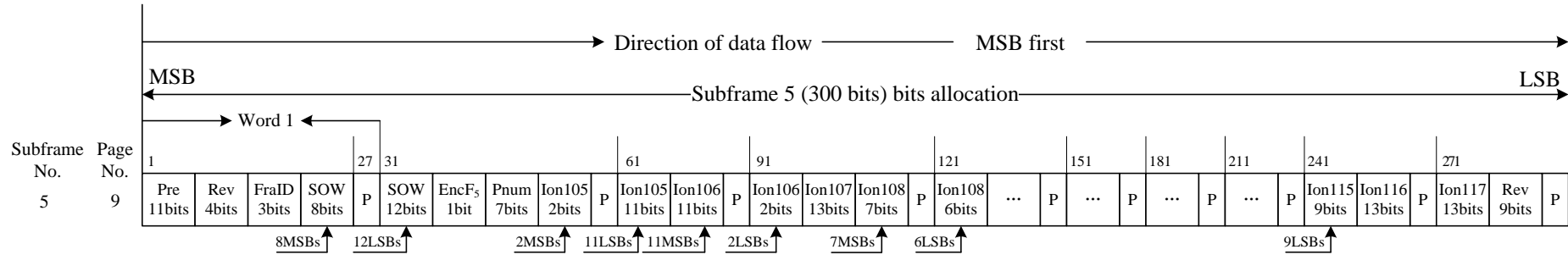

Fig 5-18-17 Bits allocation of page 9 of subframe 5 in format D2

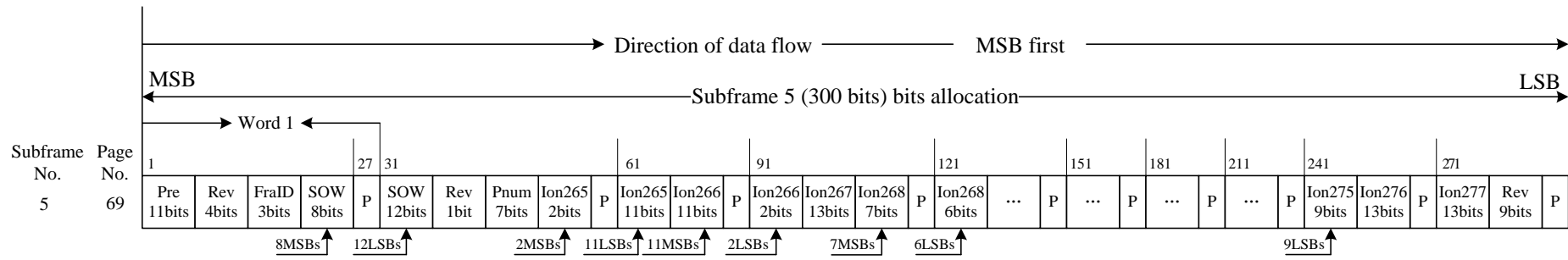

Fig 5-18-18 Bits allocation of page 69 of subframe 5 in format D2

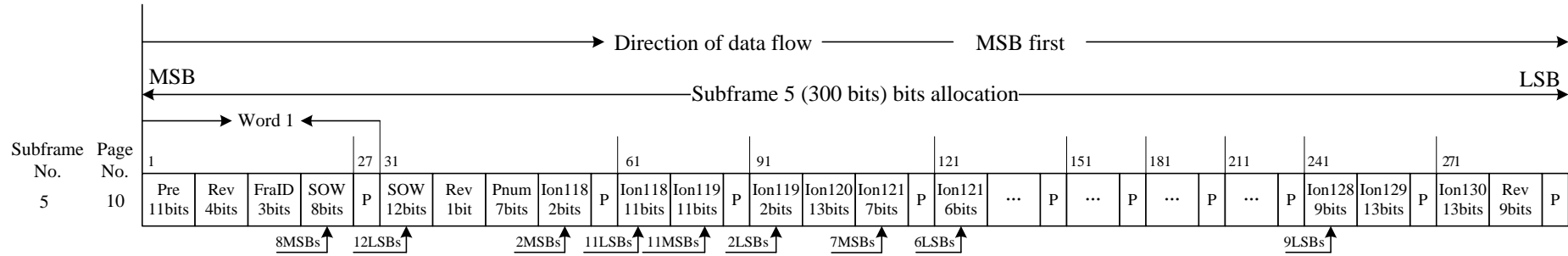

Fig 5-18-19 Bits allocation of page 10 of subframe 5 in format D2

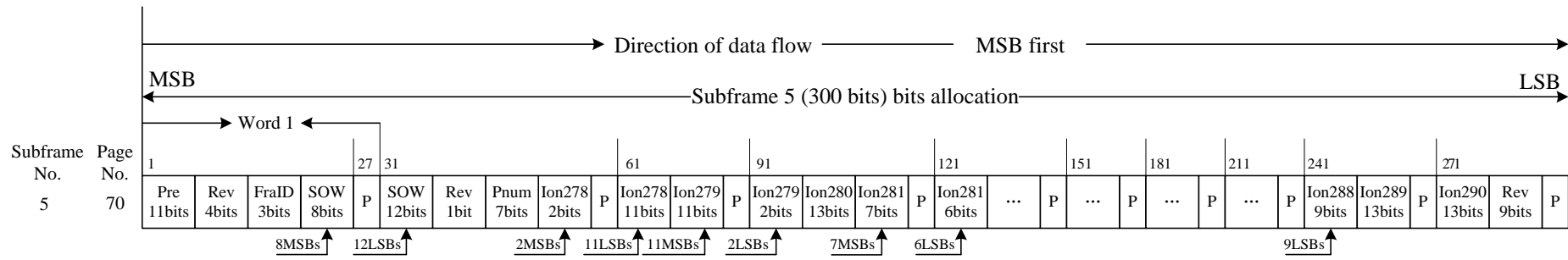

Fig 5-18-20 Bits allocation of page 70 of subframe 5 in format D2

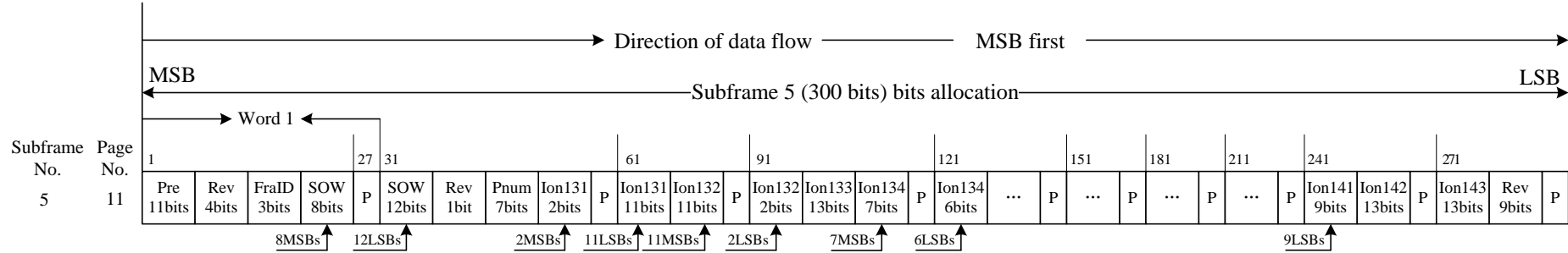

Fig 5-18-21 Bits allocation of page 11 of subframe 5 in format D2



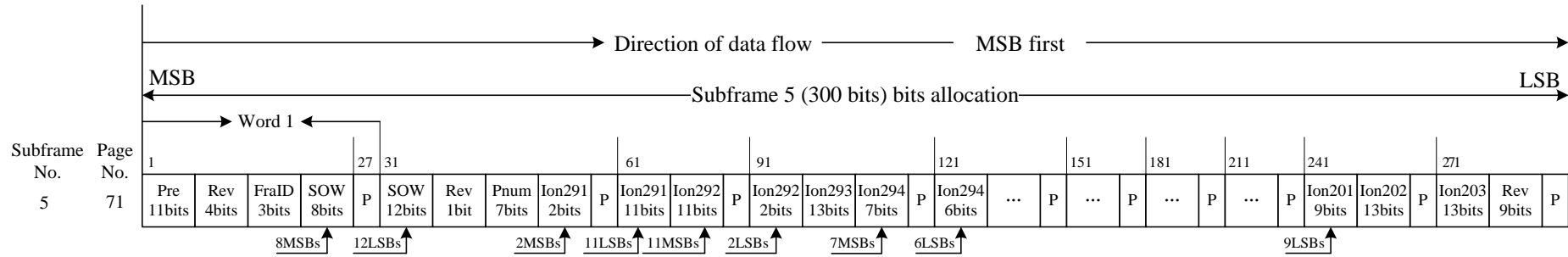

Fig 5-18-22 Bits allocation of page 71 of subframe 5 in format D2

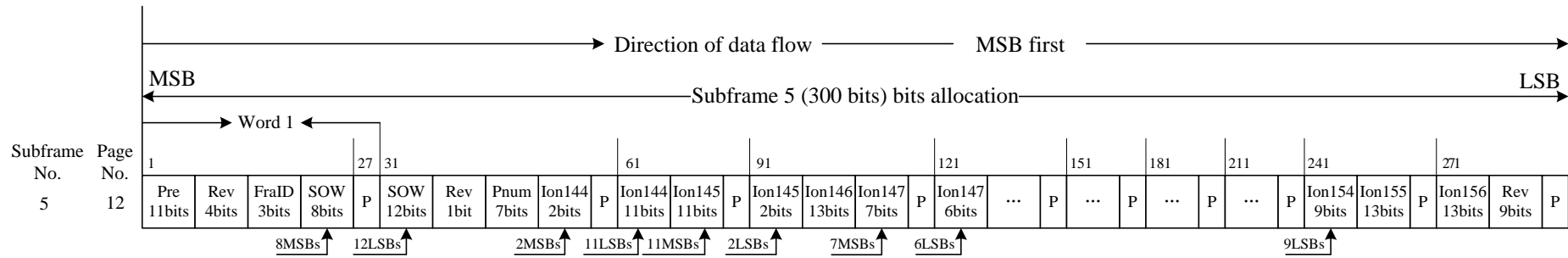

Fig 5-18-23 Bits allocation of page 12 of subframe 5 in format D2

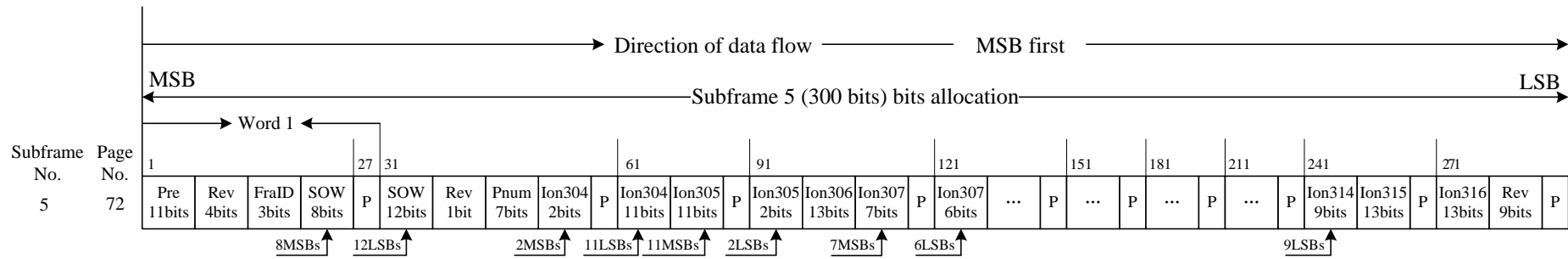

Fig 5-18-24 Bits allocation of page 72 of subframe 5 in format D2

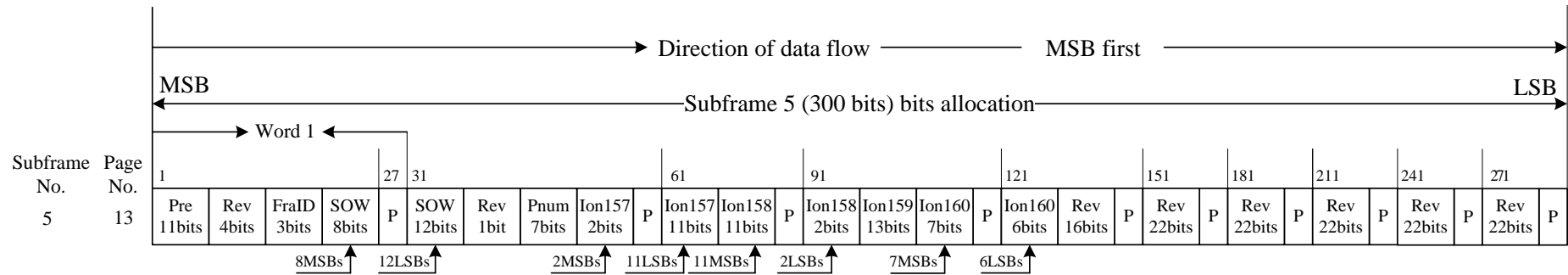

Fig 5-18-25 Bits allocation of page 13 of subframe 5 in format D2



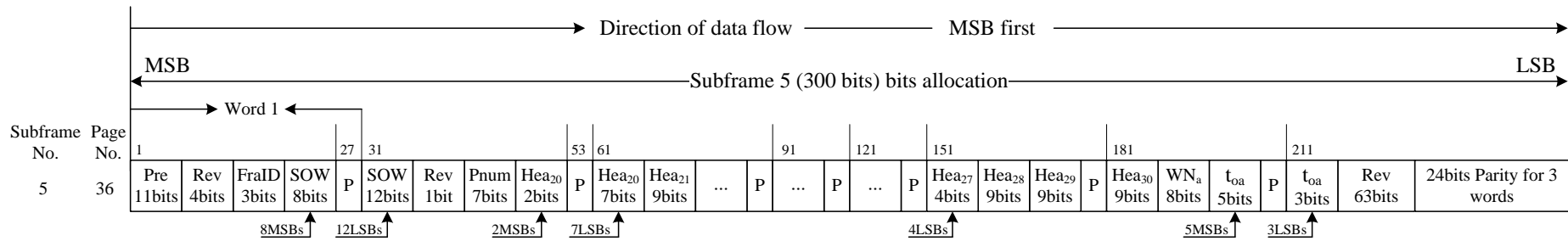

Fig 5-18-28 Bits allocation of page 36 of subframe 5 in format D2

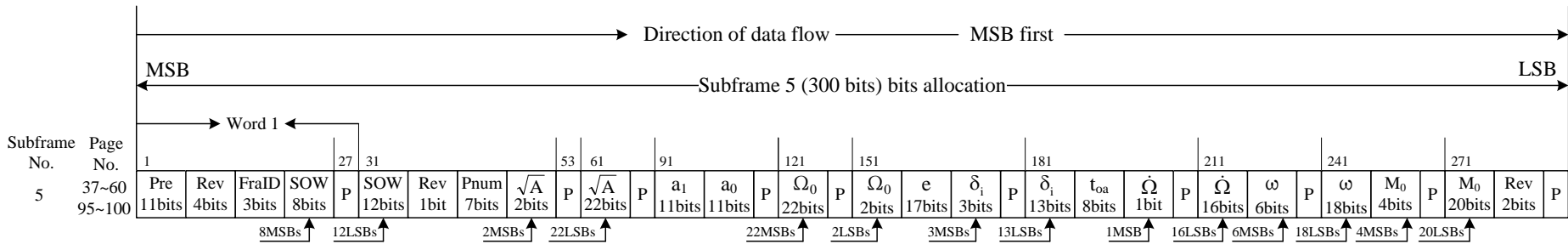
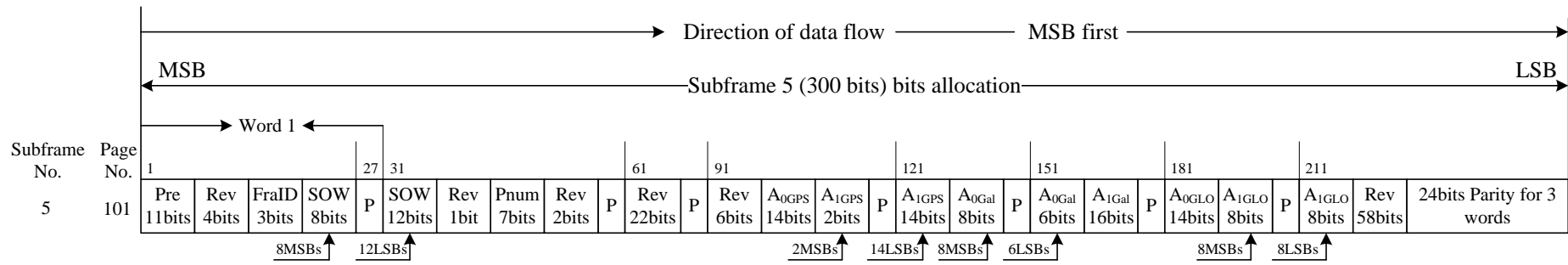
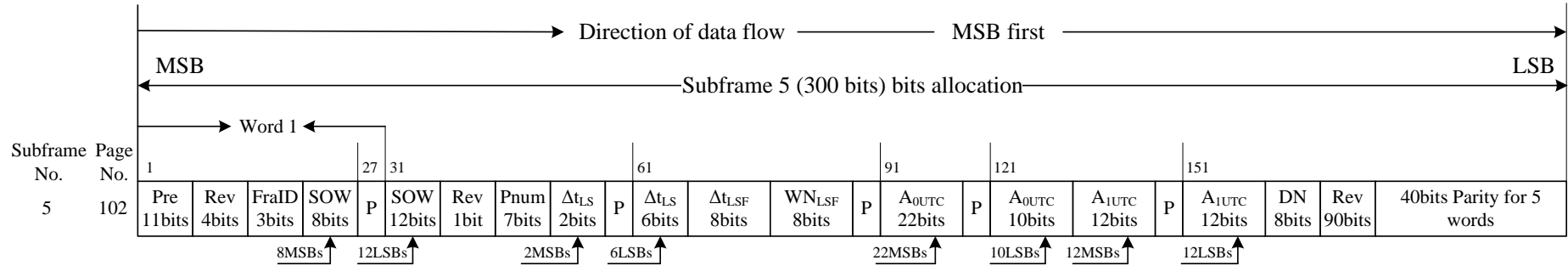

Fig 5-18-29 Bits allocation of pages 37 through 60 and pages 95 through 100 of subframe 5 in format D2



**Fig 5-18-30 Bits allocation of page 101 of subframe 5 in format D2**



**Fig 5-18-31 Bits allocation of page 102 of subframe 5 in format D2**

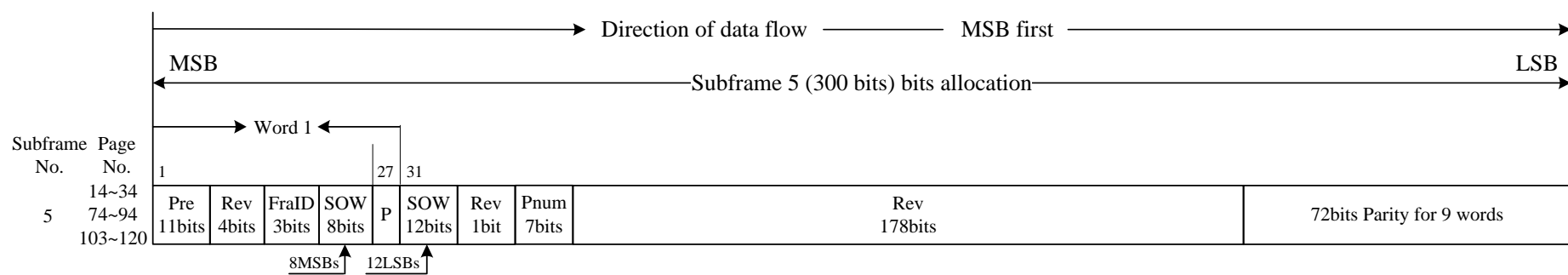

**Fig 5-18-32 Bits allocation of reserved pages 14 through 34, pages 74 through 94 and pages 103 through 120 of subframe 5 in format D2**

### 5.3.3 D2 NAV Message Content and Algorithm

D2 NAV message contains basic NAV information and augmentation service information.

#### 5.3.3.1 Basic NAV Information

D2 NAV message contains all the basic NAV information as follows:

Fundamental NAV information of the broadcasting satellite:

- Preamble (Pre)
- Subframe identification (FraID)
- Seconds of week (SOW)
- Week number (WN)
- User range accuracy index (URAI)
- Autonomous satellite health flag (SatHI)
- Ionospheric delay model parameters ( $\alpha_n, \beta_n, n=0\sim 3$ )
- Equipment group delay differential ( $T_{GD1}$ )
- Issue of data, clock (IODC)
- Clock correction parameters ( $t_{oc}, a_0, a_1, a_2$ )
- Issue of data, ephemeris (IODE)
- Ephemeris parameters ( $t_{oe}, \sqrt{A}, e, \omega, \Delta n, M_0, \Omega_0, \dot{\Omega}, i_0, IDOT, C_{uc},$

$C_{us}, C_{rc}, C_{rs}, C_{ic}, C_{is}$ )

Page number (Pnum)

Almanac information:

- Almanac parameters ( $t_{oa}, \sqrt{A}, e, \omega, M_0, \Omega_0, \dot{\Omega}, \delta_i, a_0, a_1$ )
- Almanac week number ( $WN_a$ )
- Satellite health information ( $Hea_i, i=1\sim 30$ )

Time offsets from other systems:

- Time parameters relative to UTC ( $A_{0UTC}, A_{1UTC}, \Delta t_{LS}, WN_{LSF}, DN,$

$\Delta t_{LSF}$ )

- Time parameters relative to GPS time ( $A_{0GPS}$ ,  $A_{1GPS}$ )
- Time parameters relative to Galileo time ( $A_{0Gal}$ ,  $A_{1Gal}$ )
- Time parameters relative to GLONASS time ( $A_{0GLO}$ ,  $A_{1GLO}$ )

The definition of basic NAV information is the same as that in format D1, except the page number (Pnum), seconds of week (SOW), which are different from those in format D1. Thus only the meanings of Pnum and SOW are given as follows.

(1) Page number (Pnum)

In format D2, the information of subframe 5 is broadcast via 120 pages and the page number is identified by Pnum.

(2) Seconds of week (SOW)

In format D2, the bits 19 through 26 and the bits 31 through 42, altogether 20 bits of every subframe are for the seconds of week (SOW). SOW count starts from zero at 00:00:00 of BDT on every Sunday.

In format D2, SOW refers to the leading edge of preamble first bit in subframe 1 of each frame.

### 5.3.3.2 Page Number for Basic NAV Information (Pnum1)

The bits 43 through 46, altogether 4 bits of subframe 1 are for page number of the basic NAV information (Pnum1). Pnum1 is broadcast in pages 1 through 10 of subframe 1.

### 5.3.3.3 Page Number for Integrity and Differential Correction Information (Pnum2)

The bits 44 through 47, altogether 4 bits of the subframe 2 are for the page number of the integrity and differential correction information (Pnum2). Pnum2 are broadcast in pages 1 through 6 of subframe 2.



#### 5.3.3.4 Satellite Health Flag for Integrity and Differential Correction Information (SatH2)

The satellite health flag for integrity and differential correction information SatH2 is in 2 bits. The MSB indicates the check result of the satellite for the received up-link regional user range accuracy (RURA), user differential range error (UDRE) and equivalent clock correction ( $\Delta t$ ). The LSB indicates the check result of the satellite for received up-link ionospheric grid information.

See Table 5-20 for detailed definitions.

**Tab 5-20 SatH2 definitions**

Bit allocation	Code	Definition of SatH2
MSB	0	RURA, UDRE and $\Delta t$ are good by check
	1	RURA, UDRE and $\Delta t$ are bad by check
LBS	0	Ionospheric grid information is good by check
	1	Ionospheric grid information is bad by check

#### 5.3.3.5 BDS Satellite Identification for Integrity and differential correction information (BDID<sub>i</sub>)

The BDS satellite identification for integrity and differential correction information (BDID<sub>i</sub>,  $i=1\sim 30$ ) is in 30 bits to identify BDS satellites for which the integrity and differential information are broadcast. Every bit identifies one satellite. “1” means the integrity and differential correction information for the satellite are broadcast and “0” means not.

For BDS the integrity and differential correction information of 18 satellites at most can be broadcast once continuously. Integrity and differential correction information are allocated in ascending order of the SV ID.

#### 5.3.3.6 BDS Regional User Range Accuracy Index (RURAI)

Regional User Range Accuracy (RURA), the BDS satellite signal integrity information, is used to describe the satellite signal pseudo-range error in meters.

The satellite signal integrity information is indicated with the Regional User Range Accuracy Index (RURAI). It occupies 4 bits for each satellite so the effective range of RURAI is 0 to 15. The update rate is 18 seconds. See Table 5-21 for the corresponding relationship between RURAI and RURA.

**Tab 5-21 RURAI definitions**

RURAI	RURA (meters, 99.9%)
0	0.75
1	1.0
2	1.25
3	1.75
4	2.25
5	3.0
6	3.75
7	4.5
8	5.25
9	6.0
10	7.5
11	15.0
12	50.0
13	150.0
14	300.0
15	> 300.0

### 5.3.3.7 BDS Differential Correction and Differential Correction Integrity Information ( $\Delta t$ , UDREI)

#### 5.3.3.7.1 Equivalent Clock Correction ( $\Delta t$ )

The BDS differential correction information is expressed in equivalent clock correction ( $\Delta t$ ). It occupies 13 bits for each satellite with the unit and scale factor of meter and 0.1 respectively and is expressed with two's complement. The MSB is for the sign bit (+ or -). The update rate of  $\Delta t$  is every 18 seconds.

The user adds the value of  $\Delta t$  to the observed pseudo-range to correct the

effect caused by the satellite clock offset and ephemeris error.

It means the  $\Delta t$  is not available if the value is -4096.

### 5.3.3.7.2 User Differential Range Error Index (UDREI)

User differential range error (UDRE), the BDS differential correction integrity, is used to describe the error of equivalent clock correction in meters. It is indicated by user differential range error index (UDREI). It occupies 4 bits for each satellite within the range of 1~15 and the update rate is 3 seconds. The corresponding relationship between UDRE and UDREI is shown in Table 5-22. The user shall lookup UDRE in the table to determine the accuracy of the differential correction for the satellite.

**Tab 5-22 UDREI definitions**

UDREI	UDRE (meters, 99.9%)
0	1.0
1	1.5
2	2.0
3	3.0
4	4.0
5	5.0
6	6.0
7	8.0
8	10.0
9	15.0
10	20.0
11	50.0
12	100.0
13	150.0
14	Not monitored
15	Not available

### 5.3.3.8 Ionospheric Grid Information (Ion)

The information about each ionospheric grid point (Ion) consists of the vertical delay at grid point ( $d\tau$ ) and its error index (GIVEI), occupying 13 bits altogether. The data arrangement and definitions are as follows.

**Tab 5-23 Ion definitions**

Parameter	$d\tau$	GIVEI
No. of bits	9	4

The ionospheric grid covers 70 to 145 degrees east longitude and 7.5 to 55 degrees north latitude. The area from 70 to 145 degrees east longitude and 10 to 55 degrees north latitude is divided into 160 grids of  $5 \times 5$  degrees. The definition of ionospheric grid point (IGP) numbers is listed in Table 5-24-1. Pages 1 through 13 broadcast ionospheric grid correction information according to this table.

**Tab 5-24-1 IGP numbers**

E-Log. N-Lat.	70	75	80	85	90	95	100	105	110	115	120	125	130	135	140	145
55	10	20	30	40	50	60	70	80	90	100	110	120	130	140	150	160
50	9	19	29	39	49	59	69	79	89	99	109	119	129	139	149	159
45	8	18	28	38	48	58	68	78	88	98	108	118	128	138	148	158
40	7	17	27	37	47	57	67	77	87	97	107	117	127	137	147	157
35	6	16	26	36	46	56	66	76	86	96	106	116	126	136	146	156
30	5	15	25	35	45	55	65	75	85	95	105	115	125	135	145	155
25	4	14	24	34	44	54	64	74	84	94	104	114	124	134	144	154
20	3	13	23	33	43	53	63	73	83	93	103	113	123	133	143	153
15	2	12	22	32	42	52	62	72	82	92	102	112	122	132	142	152
10	1	11	21	31	41	51	61	71	81	91	101	111	121	131	141	151

When  $IGP \leq 160$ , the corresponding longitudes and latitudes are:

$$L = 70 + \text{INT}((IGP - 1) / 10) \times 5$$

$$B = 5 + (IGP - \text{INT}((IGP - 1) / 10) \times 10) \times 5$$

Where  $\text{INT}(\ast)$  refers to round down.

The area from 70 to 145 degrees east longitude and 7.5 to 52.5 degrees north latitude is divided into 160 grids of  $5 \times 5$  degrees. The definition of IGP numbers is shown in Table 5-24-2. Pages 60 through 73 broadcast grid ionospheric correction information according to this table.

**Tab 5-24-2 IGP numbers**

E-Log. N-Lat.	70	75	80	85	90	95	100	105	110	115	120	125	130	135	140	145
52.5	170	180	190	200	210	220	230	240	250	260	270	280	290	300	310	320
47.5	169	179	189	199	209	219	229	239	249	259	269	279	289	299	309	319
42.5	168	178	188	198	208	218	228	238	248	258	268	278	288	298	308	318
37.5	167	177	187	197	207	217	227	237	247	257	267	277	287	297	307	317
32.5	166	176	186	196	206	216	226	236	246	256	266	276	286	296	306	316
27.5	165	175	185	195	205	215	225	235	245	255	265	275	285	295	305	315
22.5	164	174	184	194	204	214	224	234	244	254	264	274	284	294	304	314
17.5	163	173	183	193	203	213	223	233	243	253	263	273	283	293	303	313
12.5	162	172	182	192	202	212	222	232	242	252	262	272	282	292	302	312
7.5	161	171	181	191	201	211	221	231	241	251	261	271	281	291	301	311

When  $\text{IGP} > 160$ , the corresponding longitudes and latitudes are:

$$L = 70 + \text{INT}((\text{IGP} - 161) / 10) \times 5$$

$$B = 2.5 + (\text{IGP} - 160 - \text{INT}((\text{IGP} - 161) / 10) \times 10) \times 5$$

Where  $\text{INT}(\ast)$  refers to round down.

### 5.3.3.8.1 Vertical Delay at Ionospheric Grid Points ( $d\tau$ )

$d\tau_i$  is the vertical ionosphere delay on B1I signal at the  $i^{\text{th}}$  grid point, expressed in scale factor of 0.125 and with unit of meters. The effective range of  $d\tau_i$  is between 0 to 63.625 meters. IGP is not monitored when the  $d\tau_i$  is 111111110 (= 63.750 meters) and vertical ionosphere delay is not available when the  $d\tau_i$  is 111111111 (= 63.875 meters).

Making use of the ionospheric correction at grid points, the users compute the ionospheric correction for the intersection point of ionosphere and direction

from user to observed satellite by interpolation and add it to the observed pseudo-range. The reference altitude of ionosphere is 375 km.

### 5.3.3.8.2 Grid Ionospheric Vertical Error Index (GIVEI)

The grid ionosphere vertical error (GIVE) describes the delay correction accuracy at ionosphere grid points and is indicated with GIVEI. See Table 5-25 for the relationship between GIVEI and GIVE.

**Tab 5-25 GIVEI definitions**

<b>GIVEI</b>	<b>GIVE (meters, 99.9%)</b>
0	0.3
1	0.6
2	0.9
3	1.2
4	1.5
5	1.8
6	2.1
7	2.4
8	2.7
9	3.0
10	3.6
11	4.5
12	6.0
13	9.0
14	15.0
15	45.0

### 5.3.3.8.3 Suggestions on User Grid Ionospheric Correction Algorithm

The user can select effective data of the grid points adjacent to or nearby the observed intersection point with  $d\tau_i$  and GIVEI to design the model and compute the delay correction for ionospheric pierce point (IPP) by interpolation.

The guiding fitting algorithm for user grid ionospheric correction is given as follows:

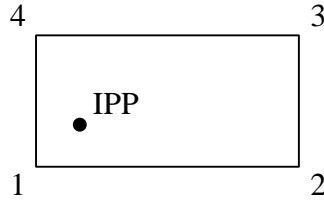

**Fig 5-19 User IPP and Grid Points**

Fig 5-19 illustrates the user IPP and its surrounding grid points. IPP, represented with geographic latitudes and longitudes as  $(\phi_p, \lambda_p)$ , is the geographic location where the line-of-sight between the user and the satellite intersects with the ionospheric layer. The positions of the four surrounding grid points are represented with  $(\phi_i, \lambda_i, i=1\sim 4)$  and the vertical ionospheric delays on the grid points are represented with  $VTEC_i(i=1\sim 4)$  respectively. And  $\omega_i(i=1\sim 4)$  shows the distance weight between IPP and the four grid points.

As long as there are at least three grid points surrounding the user IPP are available and effective, the IPP ionospheric delay can be calculated from the vertical ionospheric delay of these effective grid points through the bilinear interpolation algorithm.

$$\text{Ionodelay}_p = \frac{\sum_{i=1}^4 \omega_i \cdot VTEC_i}{\sum_{i=1}^4 \omega_i}$$

$$\text{Where, } x_p = \frac{\lambda_p - \lambda_1}{\lambda_2 - \lambda_1}, \quad y_p = \frac{\phi_p - \phi_1}{\phi_4 - \phi_1},$$

$$\omega_1 = (1 - x_p) \cdot (1 - y_p), \quad \omega_2 = x_p \cdot (1 - y_p), \quad \omega_3 = x_p \cdot y_p, \quad \omega_4 = (1 - x_p) \cdot y_p$$

If any grid point of this observation epoch is marked as ineffective, its weight is zero.

## 6 Acronyms

BDS	BeiDou Navigation Satellite System
BDT	BeiDou Navigation Satellite System Time
bps	bits per second
CDMA	Code Division Multiple Access
CGCS2000	China Geodetic Coordinate System 2000
dBW	Decibel with respect to 1 watt
GEO	Geostationary Earth Orbit
GIVE	Grid point Ionospheric Vertical delay Error
GIVEI	Grid point Ionospheric Vertical delay Error Index
GLONASS	GLOBAL Navigation Satellite System
GPS	Global Positioning System
ICD	Interface Control Document
ID	Identification
IERS	International Earth Rotation and Reference Systems Service
IGP	Ionospheric Grid Point
IGSO	Inclined Geosynchronous Satellite Orbit
IODC	Issue of Data, Clock
IODE	Issue of Data, Ephemeris
IPP	Ionospheric Pierce Point
IRM	IERS Reference Meridian
IRP	IERS Reference Pole
Mcps	Mega chips per second
MEO	Medium Earth Orbit
MHz	Megahertz
N/A	Not Applicable
NAV	Navigation
MSB	Most Significant Bit
NTSC	National Time Service Center
QPSK	Quadrature Phase Shift Keying



RHCP	Right-Handed Circularly Polarized
RURA	Regional User Range Accuracy
RURAI	Regional User Range Accuracy Index
SOW	Seconds of Week
SV	Space Vehicle
UDRE	User Differential Range Error
UDREI	User Differential Range Error Index
URA	User Range Accuracy
UTC	Coordinated Universal Time
WN	Week Number