

***Compatible multisystem
user equipment of the global
navigation satellite systems***

Oleg Lopatko, Ph.d., Deputy Director General
Working Group B, 18 October 2010, Turin, Italy

г. Moscow, 2010.

Joint Stock Company
Institute of Space Device Engineering



GLONASS/GPS constellation, visible SV Turin, 18.10.2010

Field of view $\pm 80^\circ$ from zenith

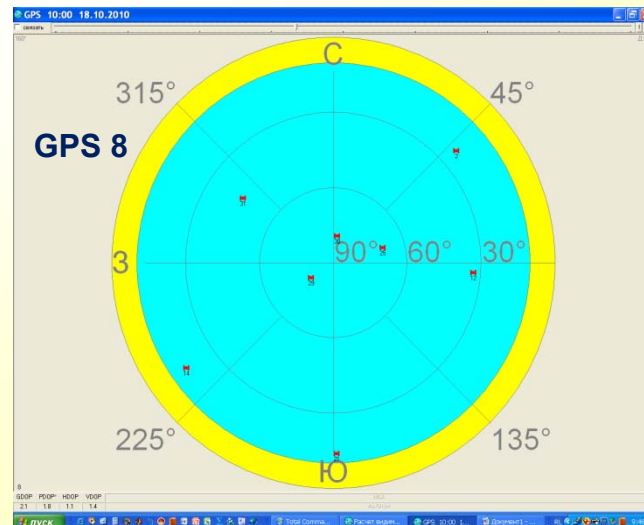
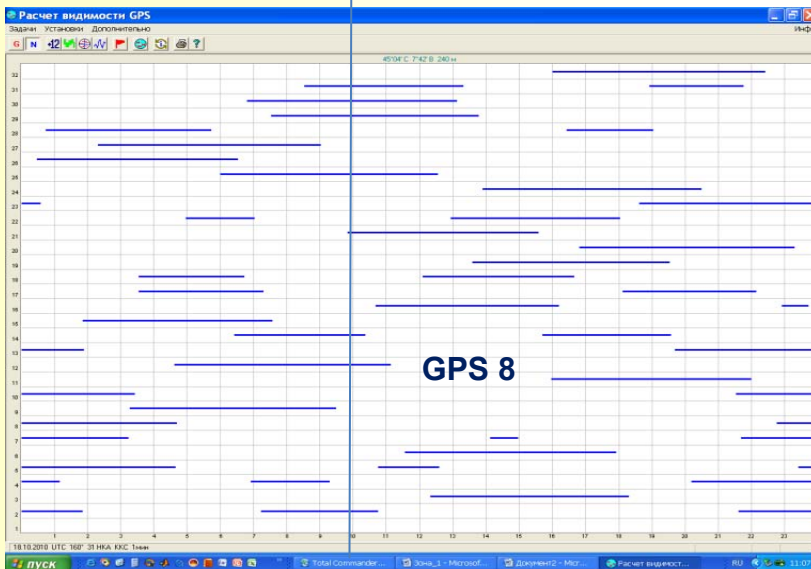
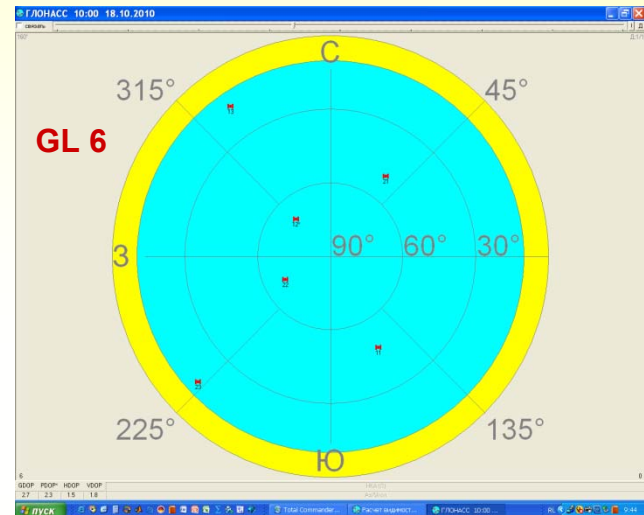
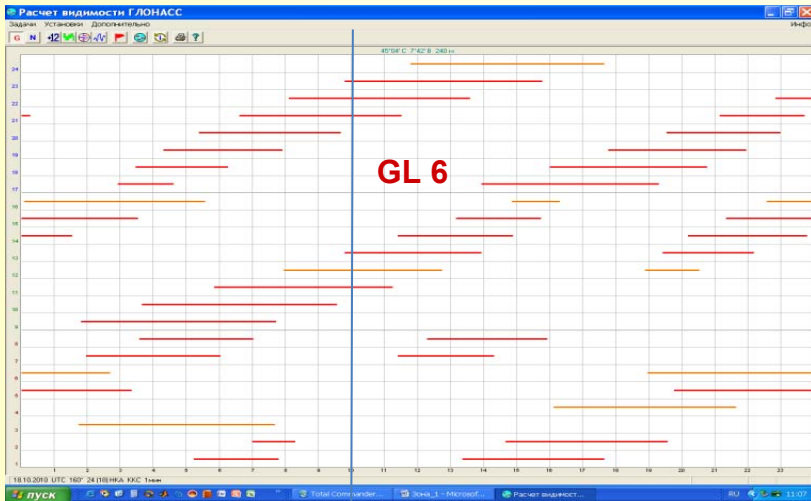

GLONASS/GPS constellation, visible SV

Turin, 18.10.2010

Field of view $\pm 40^\circ$ from zenith

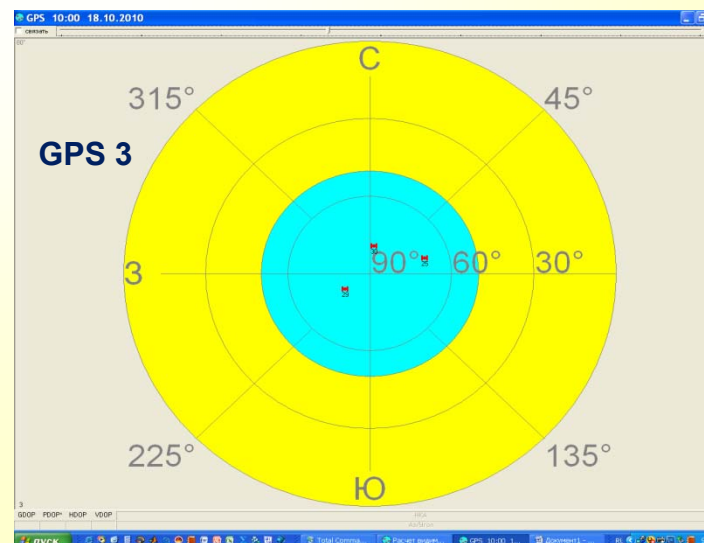
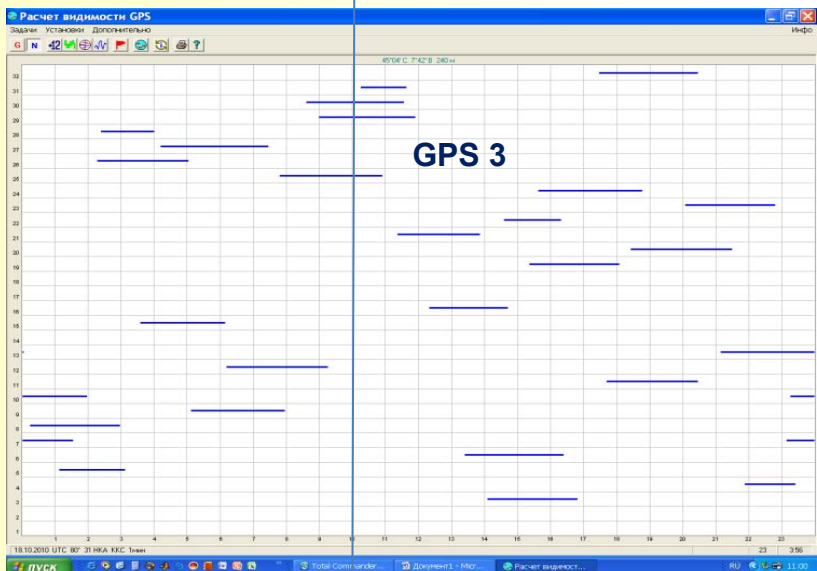
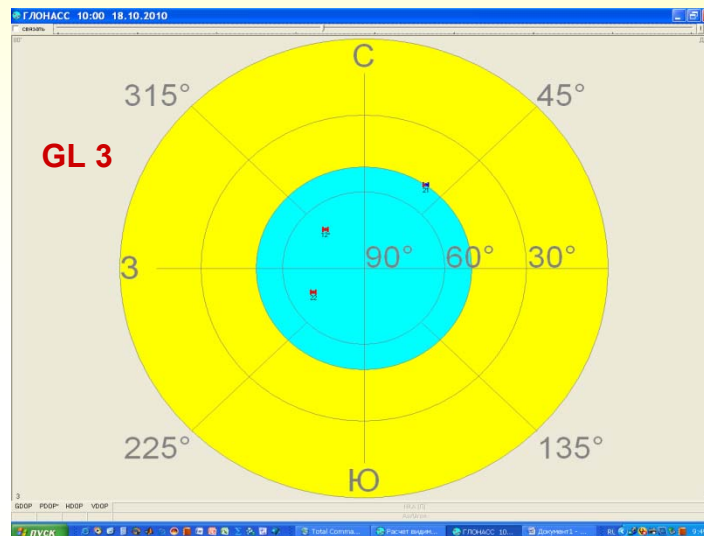
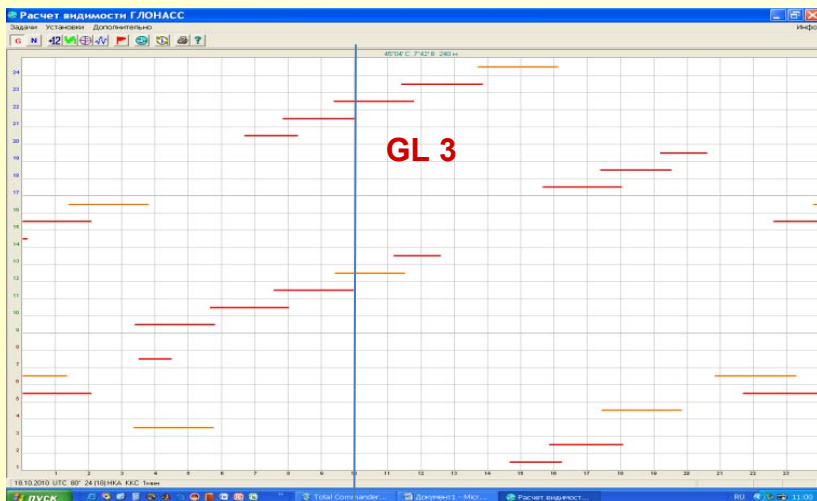

GPS/GI/Ga Interoperability

Average number of the visible SV
 Complete constellations; 1000000 points;
 equally probable distribution on the earth surface and time (8 days)

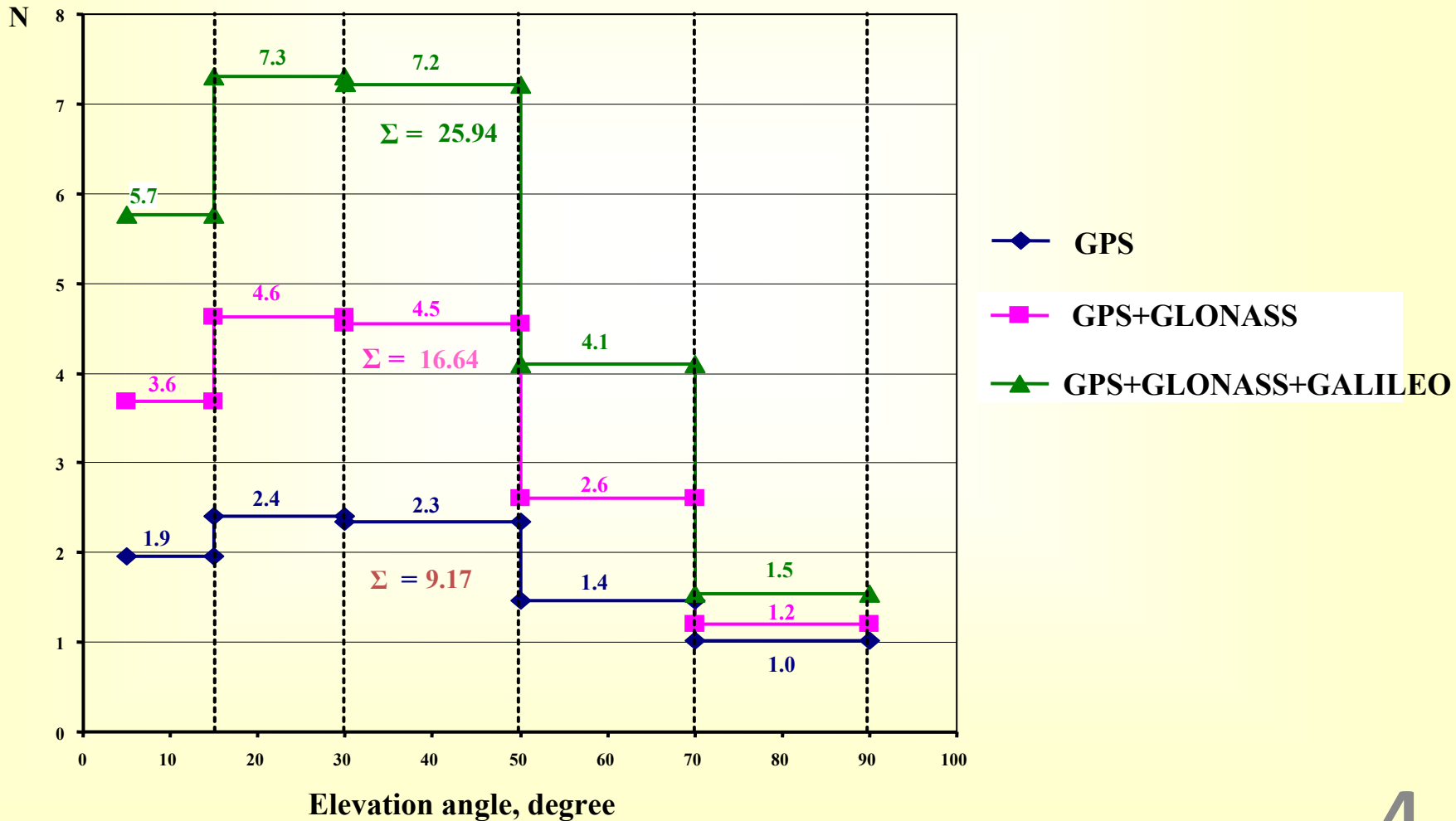

Miniature module for the GNSS GLONASS/GPS navigation receiver

Functions and capabilities:

3 serial ports RS-232 (exchange rate 2400..115200 bit/s) maintain the following exchange protocols dedicated for the reception and transmission mode

- binary protocol with a capability to transmit raw measurements;
- NMEA0183 symbolic protocol to receive and transmit the navigation data;
- RTCM SC104 reception and transmission of differential correction errors.

Time tagging to be synchronized on the time scale of GLONASS, GPS, UTC, UTC SU.
Time tagging 10Hz capability to be synchronized on the same scales

Specifications :

GLONASS - L1 band; GPS - L1 band
32 all-in-view receiving channels provided for the channels configured independently for reception

- GLONASS ПТ-code,
- GPS C/A-code,
- WAAS/EGNOS-codes.

Built-in RAIM algorithm

Positioning accuracy of coordinates/altitude in the off-line mode (CKO):

- GLONASS 10 m
- GPS 10 m

Positioning accuracy of coordinates/altitude in the differential mode (CKO):

- 1-3 / 2-5m

Positioning accuracy of a velocity vector:

- GLONASS 0,005 m/s
- GPS 0,005 m/s

Time of initial positioning under cold start - no more than 50 s.

Time restart after short miss of a satellite signal - no more than 5 s.

Update rate of navigation data transmitted - 0,1...10 Hz.

Transmission of navigation data: geodetic coordinate system BLH, rectangular geocentric coordinates XYZ, Gauss-Kruger projection XYH.

Systems of coordinates: PZ-90, CK-42, CK-95, WGS-84, WGS-72, and others (totally 64). Capability to determine an ellipsoid parameter for a user.

Operational performance:

Operation temperature	from - 40 up to + 70°C
Storage temperature	from - 60 up to + 80°C
Humidity	98% (at 25°C);

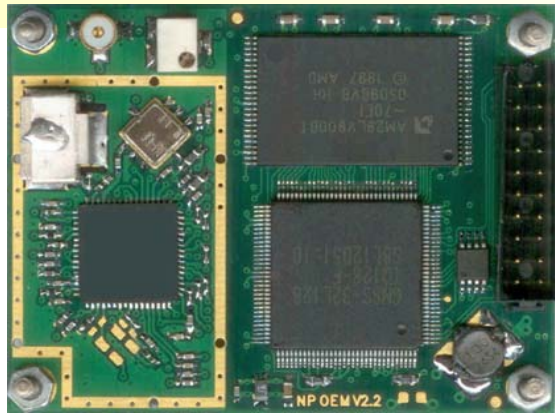

Single-board miniature GLONASS/GPS 24-channels navigation receiver "CH-4706"



Single-board 24-channels navigation receiver CH-4706 is intended for integrating to different systems. as a navigation

sensor. CH-4706 provides current positioning (latitude, longitude, altitude), user velocity vector, as well as current time value through the SNS GLONASS, GPS and SBAS.

The receiver is intended to be applied consisting of the following equipment:

- Antitheft car facilities;
- Base stations for mobile communication;
- Monitoring complexes for vehicular and railway traffic.;
- personal navigation devices;
- stations foe access WiFi, WiMAX and others
- other communication equipment.

Functions and capabilities:

The CH-4706 module comprises: - independent channels to receive the signals of SNS GLONASS and GPS, that is requisite for providing an enhanced interference immunity resistance;

- high-quality built-in RAIM algorithms are oriented for low-dynamics objects.

The navigation receiver CH-4706 provides solving of the following tasks:

- reception and processing of the SNS GLONASS, GPS, SBAS (EGNOS/WAAS/MSAS) signals via the open civil codes CT and C/A at the band of L1;
- automatic continuous generation of coordinates (latitude, longitude, attitude), current time, course and velocity;
- displaying the current coordinates on the external facilities in the coordinate system WGS-84, П3-90, CK-42, CK-95;
- updating of coordinates with the frequency of 1, 2 and 5 Hz;
- almanac reception, storage and updating of the SNS GLONASS, GPS and SBAS;
- data exchange with external systems via the NMEA 0183 protocol (IEC 1162) or via the BINR binary protocol, developed by the design engineering bureau NAVIS;
- reception and calculation of updated data based on RTCMSC-104V2.2 recommendations;

Technical characteristics:

Number of receiving channels: 24

Mode: All – in – view

GLONASS: L1-band (1592-1610 MHz), CT – code

GPS/WAAS/EGNOS: L1-band (1575.42 MHz), C/A-code

Positioning accuracy (CKO):

- Plane coordinates: in off-line operation 3 m
- in differential mode 2 m
- Altitude: 5 m - Velocity: 0,05 m/s - Time: 50 ns

Time to get the navigation parameters, no more:

- «cold start»: 90 s; - «warm start»: 30 s;
- «hot start»: 15 s;
- reacquisition after signal outage for 20 s: 5 s

Module dimensions: 35x35x6mm;

Mass, no more: 20g

;

Performance characteristics:

- operational ambient temperature : от –40 up to +75°C
- operational excessive environmental humidity: 98% (40°C)

Interface:

- Two ports for input/output RS-232E
- Communication protocols: IEC1162 (NMEA0183), BINR, RTCM SC 104 v2.2
- Data rate: up to 38400 bit/s
- SPI – interface (SCLK, SDIN, SDOUT)

Miniature navigation receiver GLONASS/GPS/GALILEO

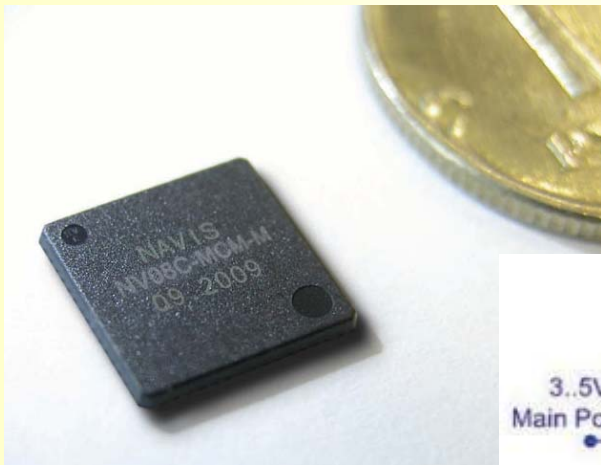

NV08C-MCM-M - miniature 32-channel navigation receiver of SNS GLONASS /GPS/GALILEO/SBAS with a low energy consumption.

It is a full-featured multichip module based on a high-efficiency NV08CD navigation processor and NV08CA analog micro chip, the additional components are not required, developed to be integrated into small size portable devices such as PDA, PND and others

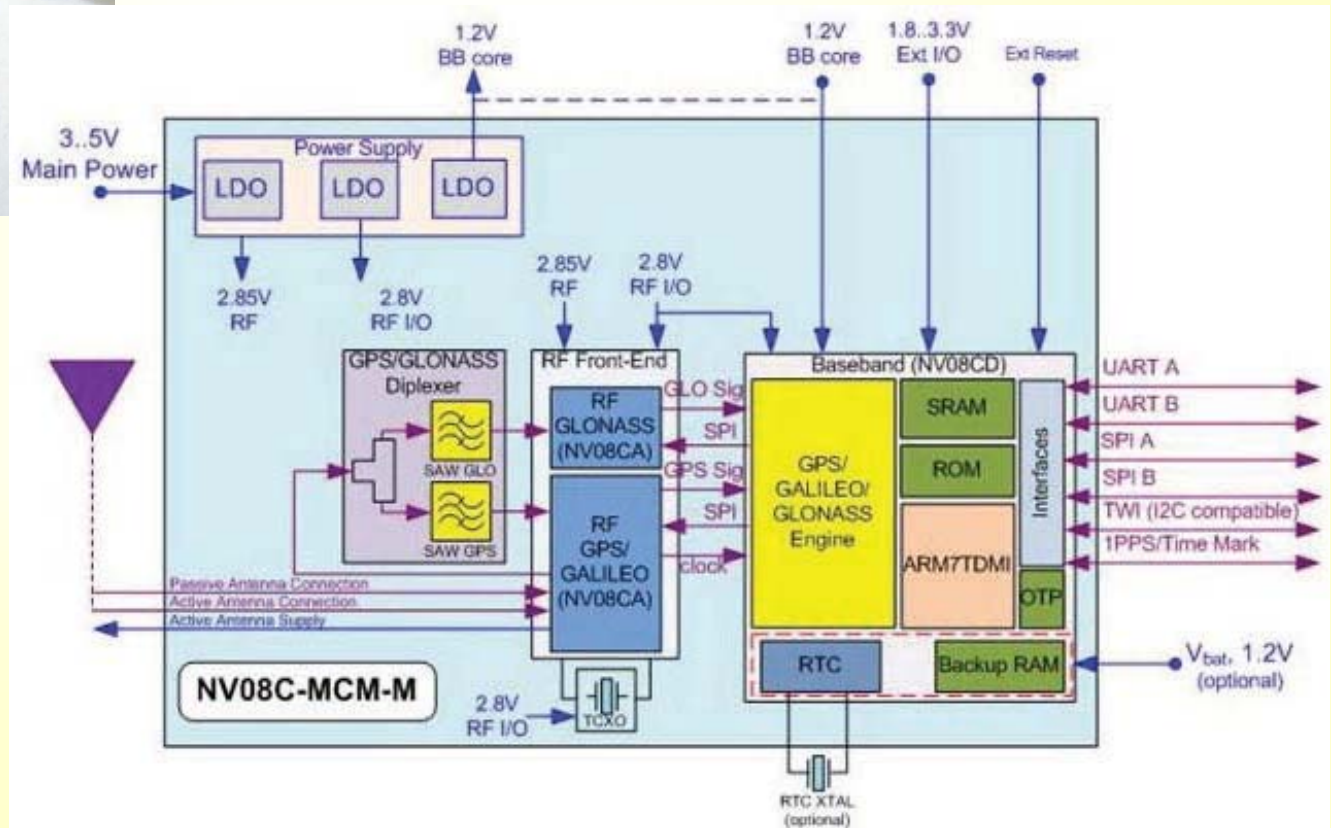

RIRT



Digital correlator family

DC16-028 digital correlator

implements the hardware signal processing of the standard accuracy signals of GNSS GLONASS CT-code), GPS (C/A-code, WAAS, EGNOS, MSAS during 1 ms.

DC18-034 digital correlator

implements the hardware signal processing of the standard accuracy signals of GNSS GLONASS CT-code), GPS (C/A-code, L2C code) WAAS, EGNOS, MSAS during 1 ms.

DC18-033 digital correlator

implements the hardware signal processing of GNSS GLONASS (CT-code, BT-code), GPS C/A-code, L2 C-code), WAAS, EGNOS, MSAS during 1 ms.

Radio-receiving unit family

Radio-receiving unit family: RFIC01, RFIC02, RFIC03 – two channel radio frequency amplifiers-converters with two-bit ADC, a PLL heterodyne frequencies synthesizer and a serial interface.

RFIC01 radio-receiving unit performs multiplication of the GLONASS, GPS standard accuracy signals operated at L1, L2-bands and transfers the signals to the low frequency for the subsequent digital processing

RFIC02 radio-receiving unit performs multiplication of the GLONASS, GPS standard and high accuracy signals operated at L1, L2 и перенос их на низкую частоту для последующей цифровой обработки.

RFIC03 radio-receiving unit performs multiplication of the GLONASS, GPS, GALILEO standard accuracy signals operated at L1, L2, L-3, L5-bands and transfers the signals to the low frequency for the subsequent digital processing



Digital chip

Block-diagram of navigation processor (64 channels)

Topology of navigation processor (0,11 μm)

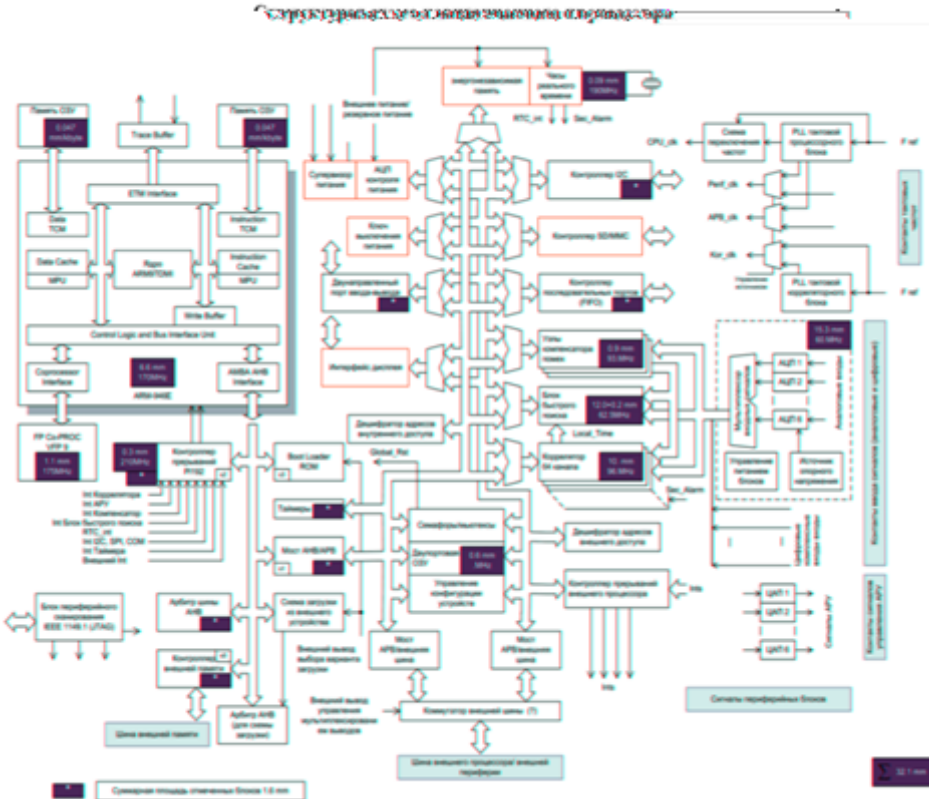

Топология микросхемы

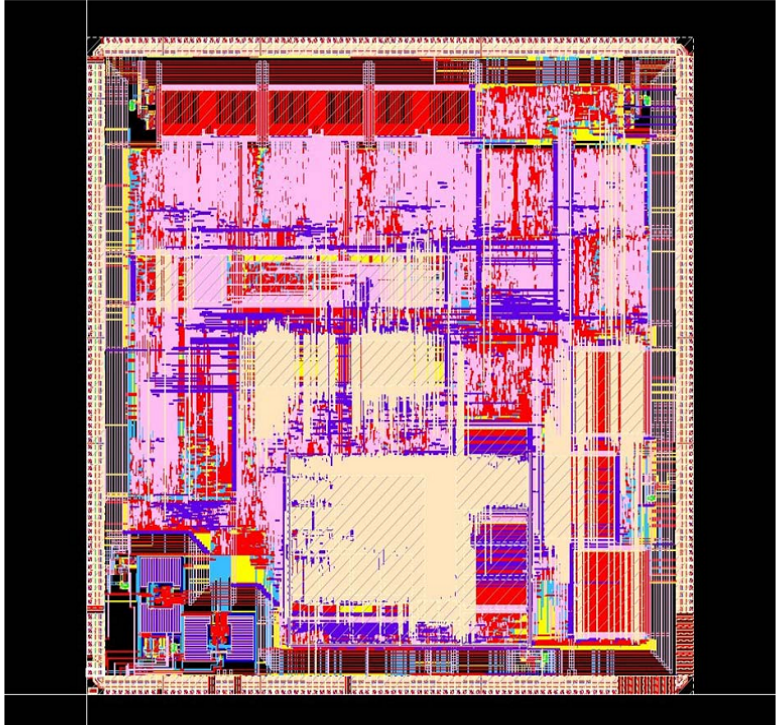

The car multimedia navigator GLOSPACE SGK-70



Specifications

Type: stationary.

Application: car.

- * Colour touch TFT LCD screen of the size 7" (17,5 cm)
- * Screen resolution 480x234 pixels (16 : 9)
- * Brightness 450 kd/m
- * Processor Samsung S3C2440 (400MHz)
- * Built-in memory 64 Mbite (SDRAM)
- * OC MS Windows CE 5.0
- * Memory map SD
- * Memory 1 Gbite complete with micro SD card
- * GLONASS Receiver 12 channels
- * GPS Receiver 20 channels
- * Built-in / remote antenna
- * USB interface: USB1.1 Host, USB 1.1 Client
- * AV-IN input
- * Adapter for ear-phones
- * Power supply 12 V 2 A
- * Dimensions/weight 188x120x35 mm / 400 g

Functions:

- * Contains preloaded maps. A map of Moscow complete with a near Moscow region map (for sale in Moscow)
 - * Compatible with a pager SMILINK to display traffic jams of roads in real time
 - * Features pre-programmed points-of-interest considering traffic jams
 - * Screen brightness adjustable
 - * Voice guidance
 - * Built-in MP3 / MPEG4 player:
 - Video VideoFile (AVI, DIVX), MPEG4 File (MP4, M4A),
 - MPEG Movie File (MPEG, MPG, MPV, DTA)
 - Multi Media Format :
 - MPEG Audio File (MP1, MP2, MP3, MPA), Matroska File (MKV, MKA), Ogg Vorbis File (OGG, OGM) Audio
 - * Images JPG, TIF, PNG
 - * FM-receiver (option)
 - * Built-in computer games
- Operation manual, network adapter 220 V,
car adapter 12 V, bracket to mount on a windshield, commutation cords

Personal navigator GLONASS/GPS



1. PURPOSE:

Determination of current coordinates, ground speed and a user routing via the SNS GLONASS/ GPS signals, service task solution, calculation of direction angle, storage of significant points and routings, position indication in a map

2. Unit comprises:

- electronic unit with a built-in antenna;
- external navigation antenna;
- battery charger – electric power supply;
- spare accumulator unit.

3. SPECIFICATIONS:

1. Frequency band for receiving channels - L1 (1,6 GHz).
2. Type of satellite signals - GLONASS (ПТ-code) and GPS (C/A-code).
3. Number of independent (parallel) receiving channels - 32.
4. Time off first determination at cold/hot start no more, s - no more 90 / 35.
5. Coordinate update rate - 1 s.
6. Coordinate system - ПЗ-90, WGS-84, СК-42, СК-95 and system of elevations of Baltic sea.
7. Determination error/ GLONASS , no more
 - location coordinates - 10 m;
 - component of velocity vector - 0,005 m/s.
8. Functions:
 - selection of GLONASS and/or GPS auto-or specified by an operator ;
 - automatic computation, display and delivery of location coordinates, velocity and time values to external users;
 - data recording and storage (memory 256 Mbyte, data capacity):
 - number of files - 2048;
 - coordinates of reference points. - 522000;
 - total routing length, mln of points - 3.3;
 - duration of data recording, h - 83,8.
9. Interface for data exchange - 2 ports RS-232; by 1 port of RS-485, USB.
10. Reception and display of differential corrections.
11. Continuous operation via 1 accumulator unit - no less 15 h.
12. Power supply - accumulator unit, standard batteries AA, mains adapter.
13. Power consumed - no more 0,35 W.
14. Mass with accumulator unit - 0,28 kg.
15. Dimensions - 170×70×40 mm.
16. Temperature range - from -30 up to + 55°C.

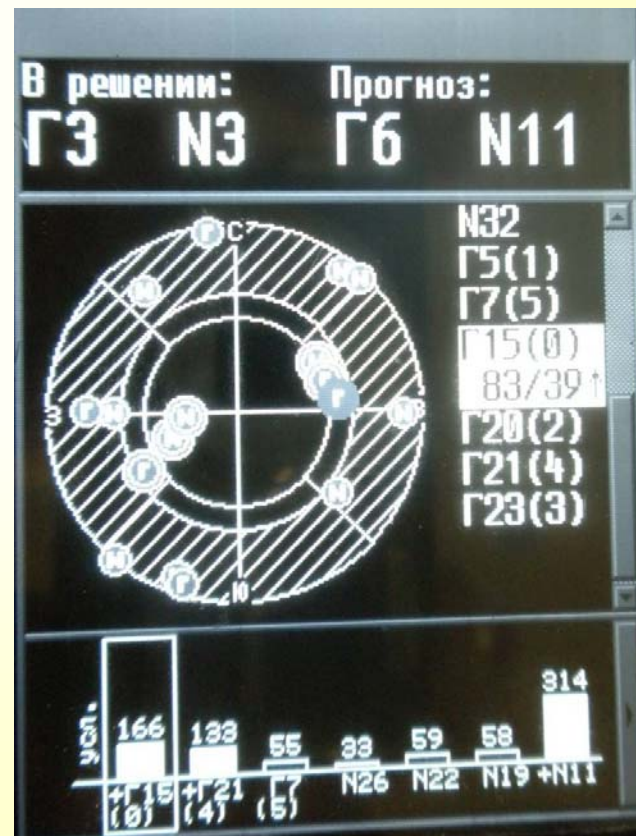

Personal «HT-1813» navigator of the GLONASS /GPS satellite systems



Personal «HT-1813» navigator of the GLONASS/GPS satellite systems

designed to determine the position coordinates, time, course, velocity, as well as for servicing an individual user on route at any time of year and day.

«HT-1813» provides:

- Signal reception and integrated processing of data from GNSS GLONASS/GPS and SBAS;
- User positioning determination;
- Calculation of trajectory parameters, service problem solving, as well as time and date determination;
- Recording and route display;
- Playback of audio/video files.

Functional capabilities:

Navigation data display on a colored electronic map induced on a display. Communication with external units via the USB communication channel.

The receiver employs a colored interactive display. It is liable to be used in an open ground and within the interior of a mobile object, it operates both via the built-in antenna and external marine or car antenna.

GLONASS/GPS high-precision geodetic equipment



High-precision geodetic equipment is designed for:

- execution of survey works for geodetic networks of various purposes;
- topographical survey and design and survey works;
- database support of land cadastre and monitoring of land use;
- relative determinations of plane coordinates and altitudes

Configuration of geodetic equipment :

- navigation receiver with information storage;
- geodetic antenna with 3 m cable;
- power adapter – charger;
- radio modem;
- rechargeable battery

Mean square error:

- static mode/fast static mode – $3 \text{ mm} + 0,5 \text{ mm/km} + 5 \text{ mm} + 1,0 \text{ mm/km}$
- RTK mode (up to 10 km) – $10 \text{ mm} + 1,5 \text{ mm/km}$
- Kinematic mode with postprocessing (up to 10 km) – $10 \text{ mm} + 1,5 \text{ mm/km}$

Navigation receiver characteristics:

- SIS – L1 C/A, L2C GPS, L1 SA, L2 SA GLONASS;
- number of channels – 64;
- frequency of coordinate updating – 1 s;
- maximum time of information storage – 7 days;
- coordinate systems – EP-90.02, WGS-84, SC-42, Gauss-Kruger projection;
- continuous operation time – up to 8 h from internal battery;
- temperature of operation – from -40°C to $+50^{\circ}\text{C}$.

Motor transport tracking based on the GLONASS/GPS technology

14

GLOSPACE SGK-T - Satellite Navigation Automobile Tracker

The hardware has been designed and accustomed for batch production since 2008

GLOSPACE SGK-T is an automobile tracking logger which provides positioning coordinates upon the GLONASS/ GPS signals.

Embedded GSM and GPRS modules provide a compatibility to identify an automobile coordinates and to track its route. Thus, the automobile is monitored permanently.

GLOSPACE SGK-T is recommended for permanent application in cars and trucks.

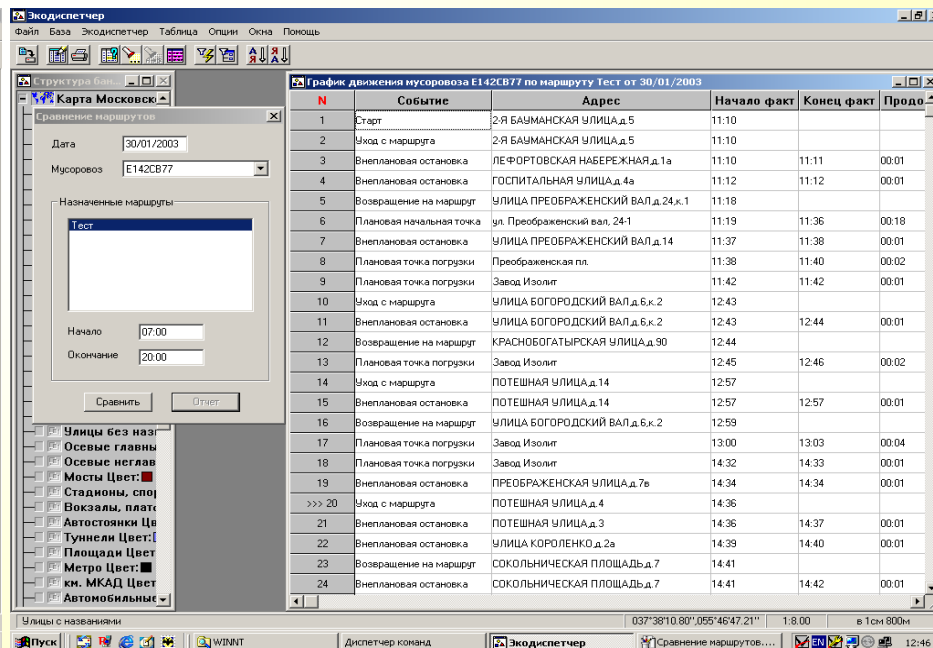
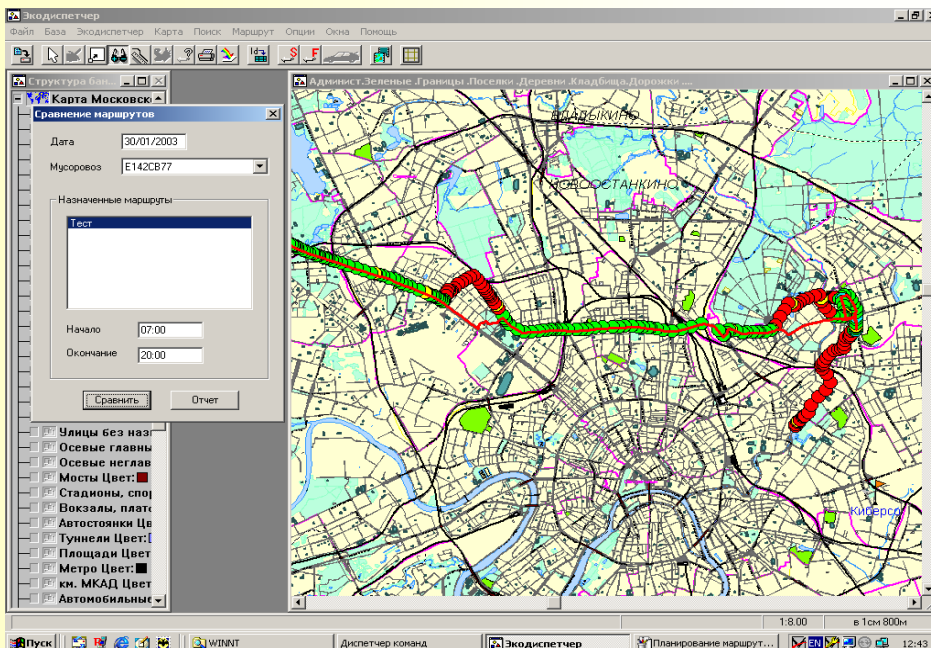

Personal radio beacon GL/GPS PARM-406

JSC «НИКР»

15



The hardware has been designed and serially produced since 2007

1. ASSIGNMENT

The PARM-406 personal radio beacon is intended for the definition and transmission of crash scene coordinates, for reduction of search & rescue service to the place of crash.

The radio beacon is primarily recommended for application by search & rescue services, and also by tourists, climbers, geologists, hunters etc.

2. DESCRIPTION

The PARM-406 personal radio beacon comprises:

the GLONASS/GPS receiver with antenna, ПРД-406 and ПРД-121 transmitters, the ANT-ARM antenna, coordinates and service information display, self-contained power supply.

3. CHARACTERISTICS

Carrier frequency: ПРД-406 - 406.028 MHz
ПРД-121 - 121.5 MHz

Power: ПРД-406 – 5,0 W
ПРД-121 – 0,1 W

Frequency instability:
Long-time ± 5 kHz (within 5 years)
Short-time 2×10^{-9} for 0,1 sec

Message emission period ПРД-406 – 50 s

Message length ПРД-406 – 440/520 ms

Operating temperatures range: $-20^{\circ}\text{C} \dots +55^{\circ}\text{C}$

Time of continuous running:
not less than 24 hours at frequency 406.028 MHz
not less than 48 hours at frequency 121.5 MHz

GLONASS/GPS 24-channels receiver

Weight-dimensions performances:
(57x75x172) mm, 420 Gram 420 Gram

4. CONFORMITY TO THE STANDARDS

Personal radio beacon PARM-406 corresponds completely following documents:

- COSPAS-SARSAT Specification C/S T.001
- COSPAS-SARSAT 406 MHz distress beacon type approval standard C/ST.007”
- Standard “СТО-MCC.01-2006” of FSUE “Morsvyazsputnik”

The radio beacon have the COSPAS-SARSAT

Type Approval Certificate № 177 yielded in 2007 July 30

5. The design of the personal radio beacon ПАРМ-406 has:

- The diploma and Gold medal of 35-th International Salon of Inventions , New Technology & Goods “Geneva-2007”
- The diploma of the “RusPatent”
- The diploma of Ministry of Education and Science
- The diploma and Silver medal of 36-th International Salon of Inventions, New Technology & Goods “Geneva-2008”
- The diploma of the “RusPatent”

Use of GLONASS/GPS receiver in search&rescue equipment



15.04.2010. Borneo station 80 km to the North Pole



South Pole

GLONASS/GPS constellation, visible SV North Pole, 18.10.2010

Field of view $\pm 47^\circ$ from zenith

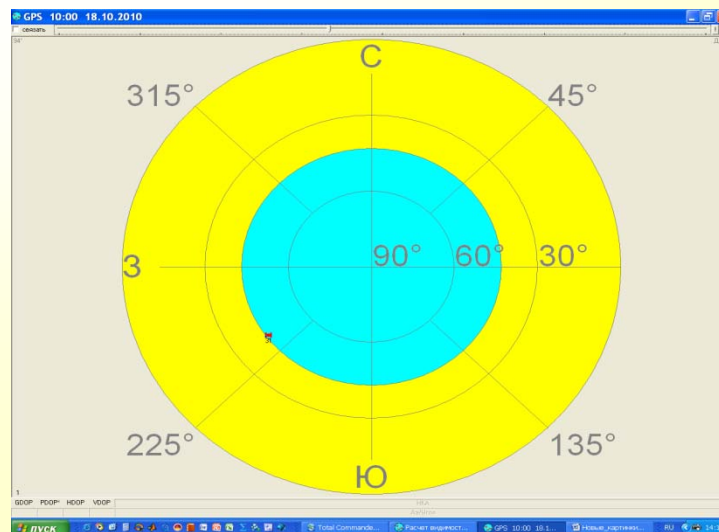
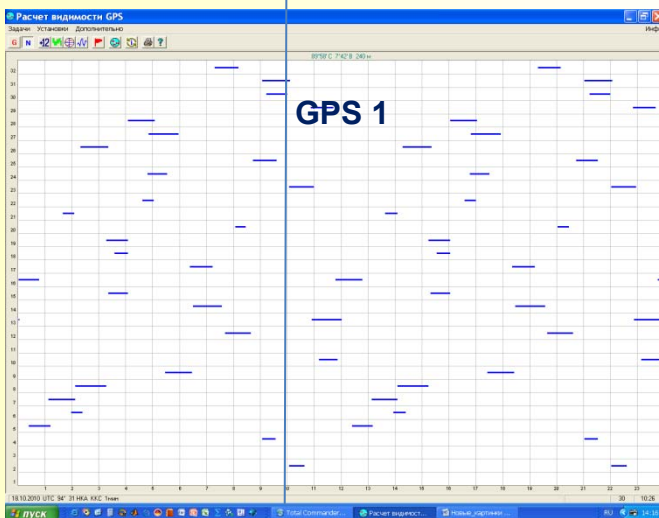
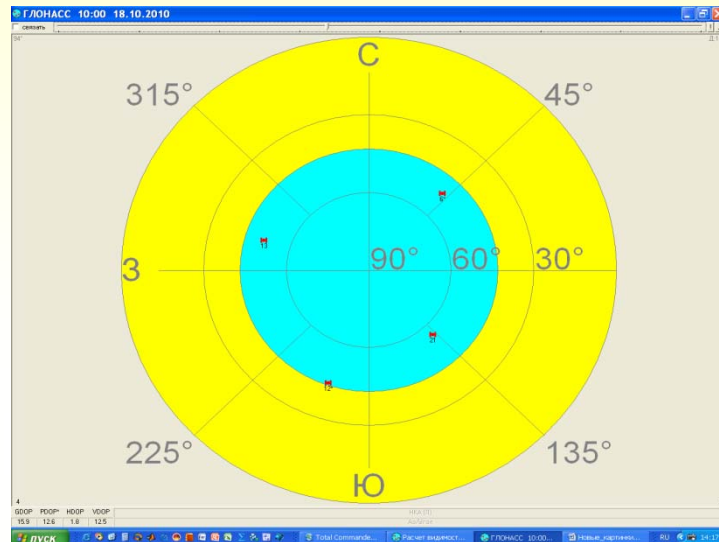
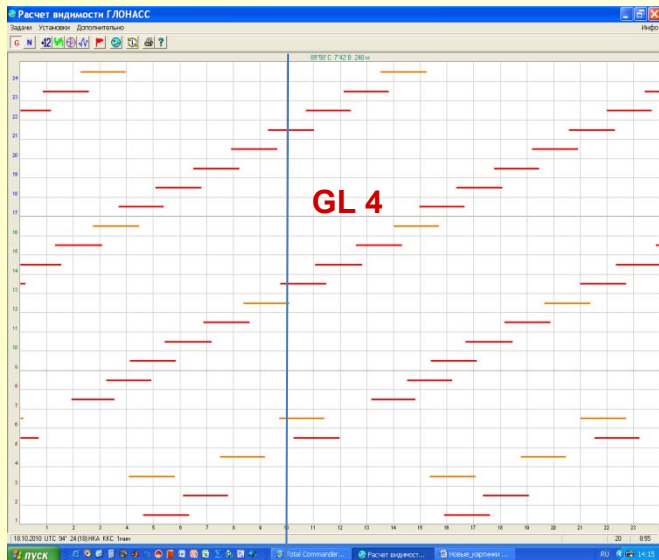

Descent module «Soyuz TMA-14,15» search&rescue operations with

“ПАРМ-406” GLONASS / GPS

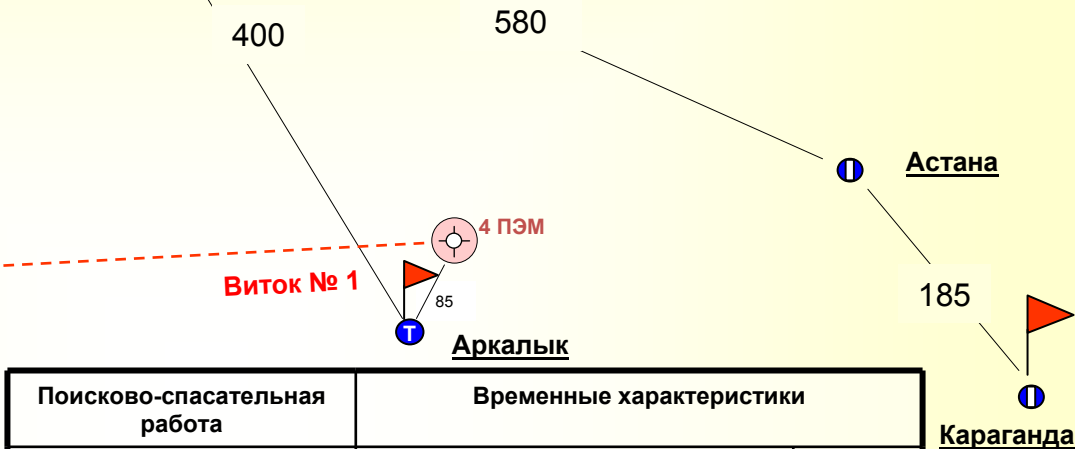

Поисково-спасательная работа	Временные характеристики	
	«Союз ТМА-14» 11.10.2009	Включение Р/ маяка
Получение сигнала в МКВЦ		9 ч. 01 мин.
Отображение сигнала р/маяка на ГК ЦПС (г. Москва) и ЦУП (г.Королёв)		9 ч. 03 мин.
Время прохождения сигнала составило – 16 минут		
«Союз ТМА-15» 01.12.2009	Включение Р/ маяка	10 ч. 34 мин.
	Получение сигнала в МКВЦ	10 ч. 38 мин.
	Отображение сигнала р/маяка на ГК ЦПС (г. Москва) и ЦУП (г.Королёв)	10 ч. 42 мин.
Время прохождения сигнала составило – 08 минут		

Байконур