

The 8th Meeting of International Committee on GNSS

# BDT Performance and Time Offset Analysis

Cai Zhiwu, Han Chunhao  
Lin Yuting, Wang Xianglei

*Beijing Satellite Navigation Center  
October 2013*

北斗



## Contents

- 1、 The definition and realization of the BDT
- 2、 BDT performance evaluation
- 3、 BDT/GPST time offset measurement
- 4、 BD/GNSS time offset parameter template
- 5、 Summary



北斗



# 1、The definition and realization of the BDT

## ■ Definition of BDT

- The BeiDou system time ( BDT ) is an internal time scale, without leap second
- The largest unit used to stating BDT is one week, defined as 604,800 seconds
- BDT is counted with the week number (WN) and the second of week (SOW)
- The zero point is 1 January 2006 (Sunday) UTC 00h 00m 00s





# 1、The definition and realization of the BDT

## ■ The relation among GNSS time systems and UTC

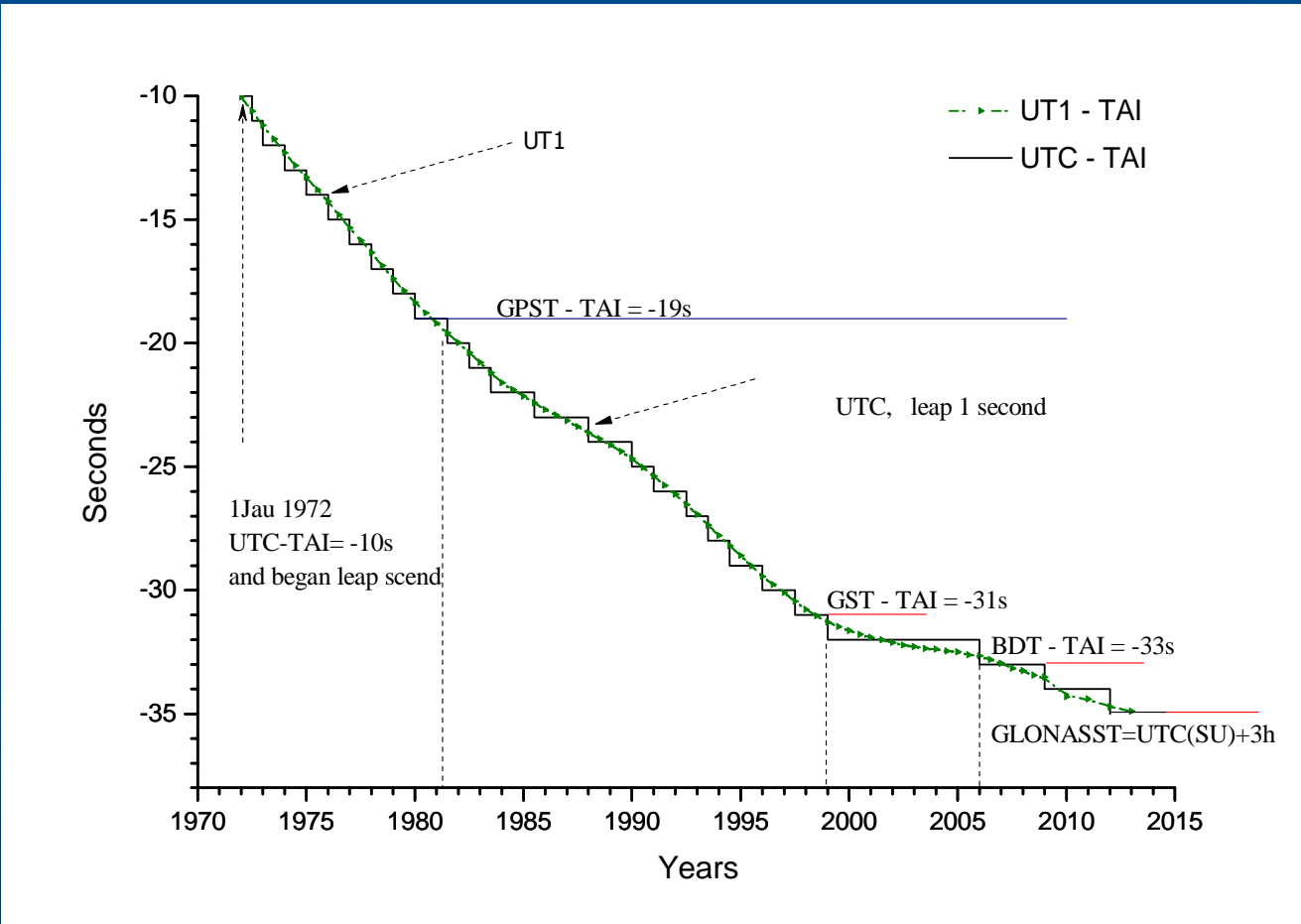



# 1、The definition and realization of the BDT

## ■ Realization of BDT

- BDT is a composite clock realized by a clock ensemble
- BDT is maintained by a time and frequency system (TFS) located at the master control station (MCS)



北斗



# 1、The definition and realization of the BDT

## ■ Structure of TFS(Time and Frequency System)

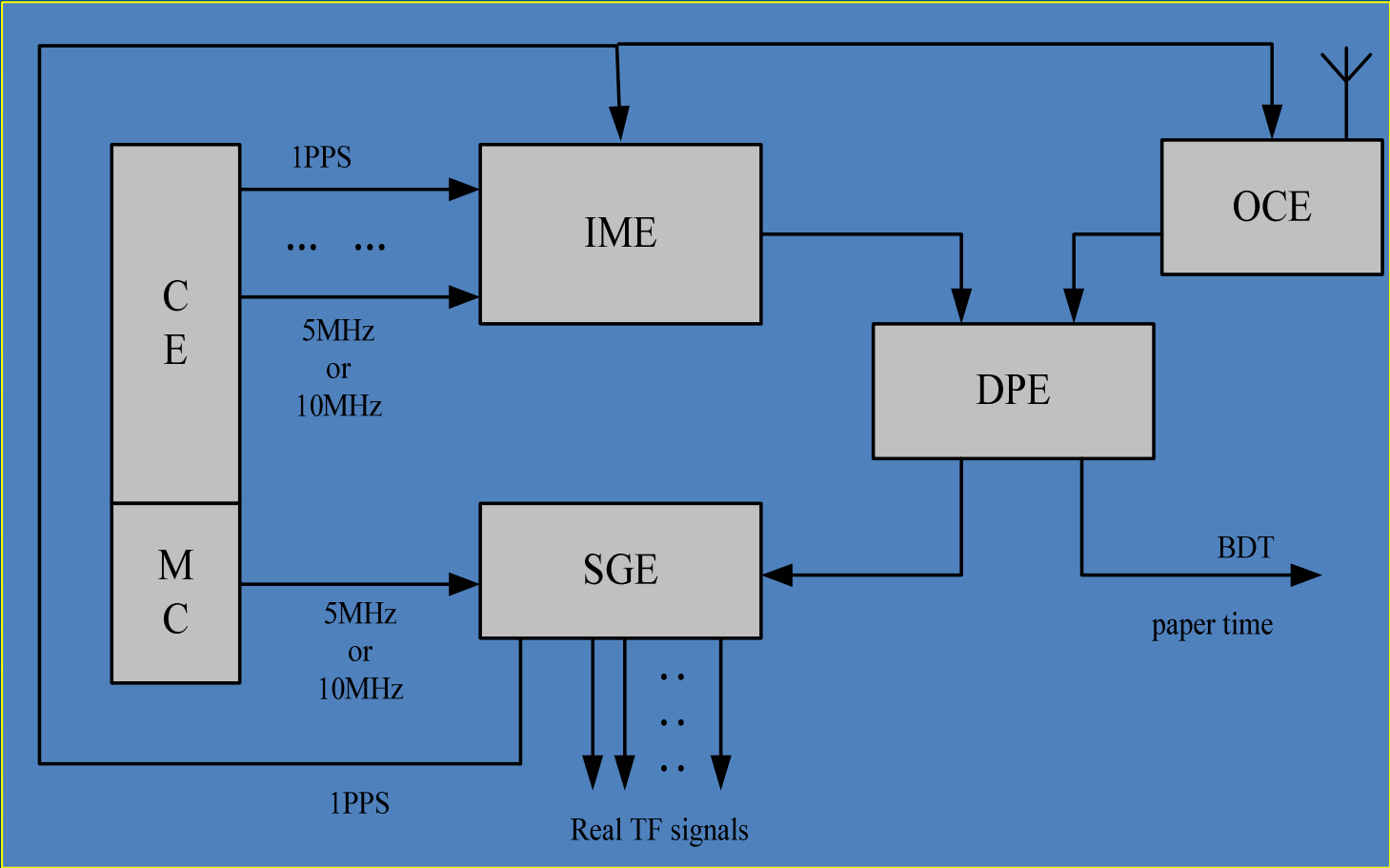



# 1、The definition and realization of the BDT

## ■ Performance Design of BDT

Frequency accuracy :  $< 1.0E-13$

Frequency stability :  $< 2.0E-14$  /1day  
 $< 1.0E-14$  /7days

Time deviation:  $|BDT-UTC| < 100ns$  (modulo one second)



北斗



# 2、BDT performance evaluation

## ■ BDT time comparison links

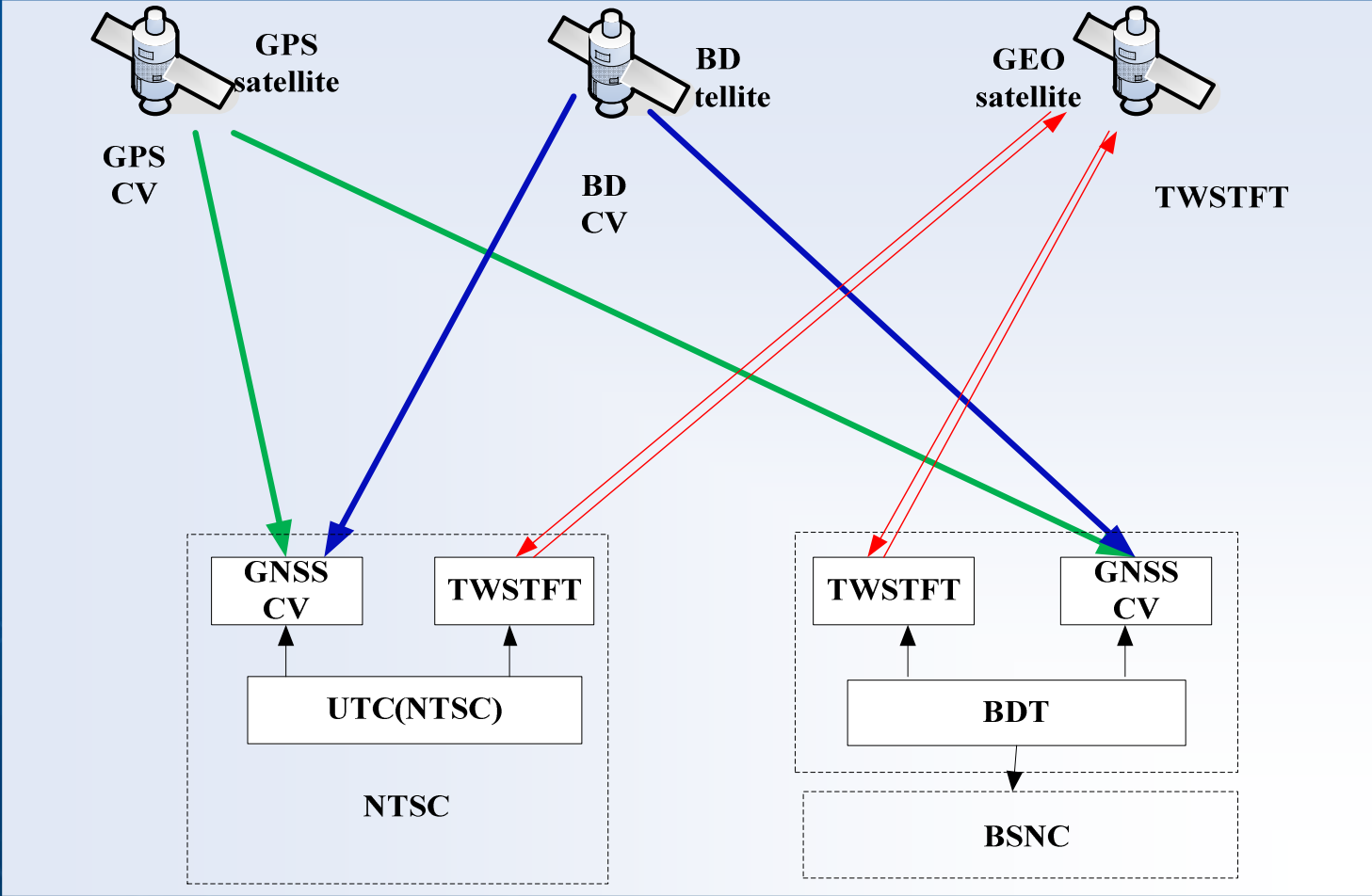



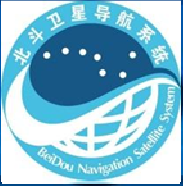

## 2、BDT Performance evaluation

### ■ Time offset between BDT and UTC (NTSC) (6 Jan.-29 Sept.)

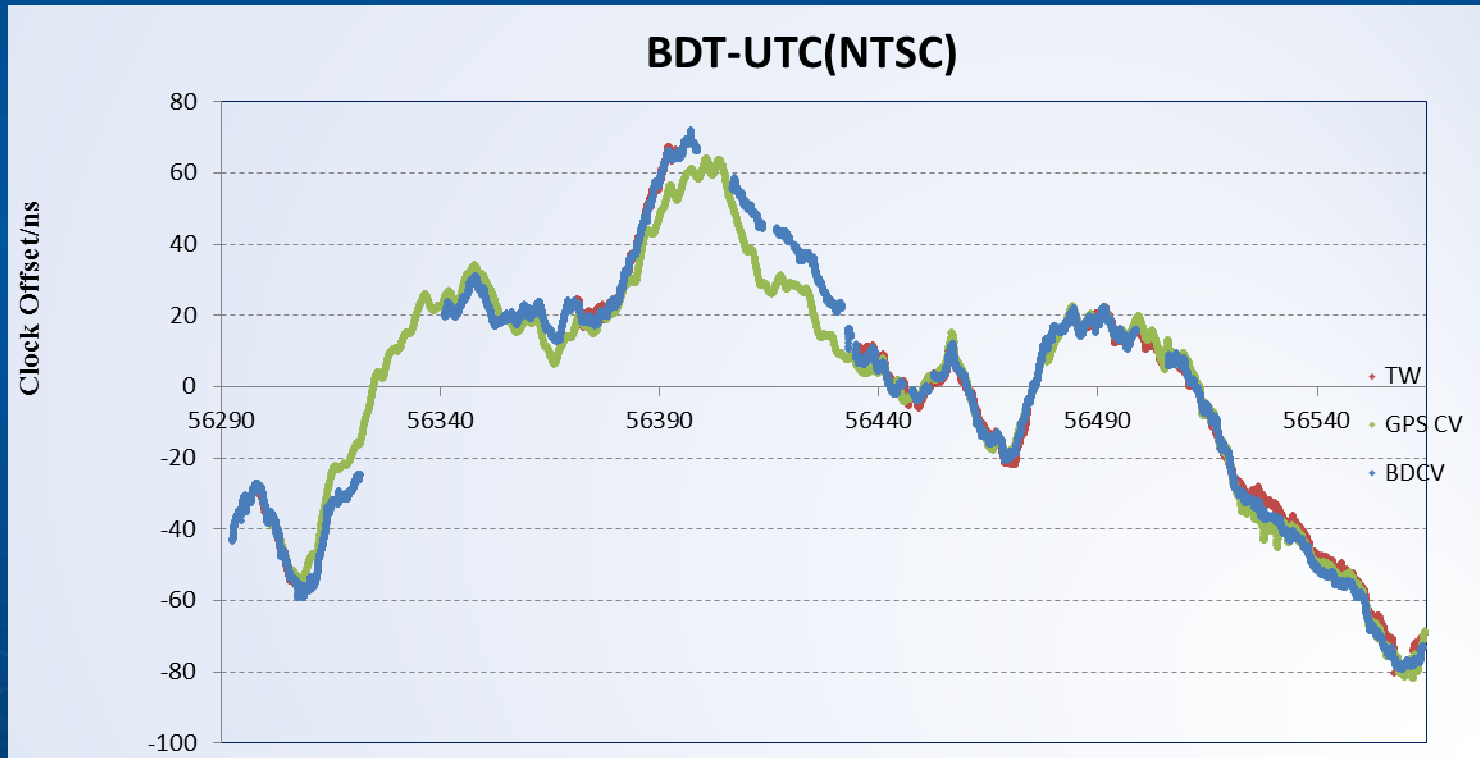

**$|\text{BDT-UTC}| < 100\text{ns}$ , control the system time as little as possible**

北斗



## 2、BDT Performance evaluation

### ■ Time offset between BDT and UTC (2 Jan.-31 Aug.)

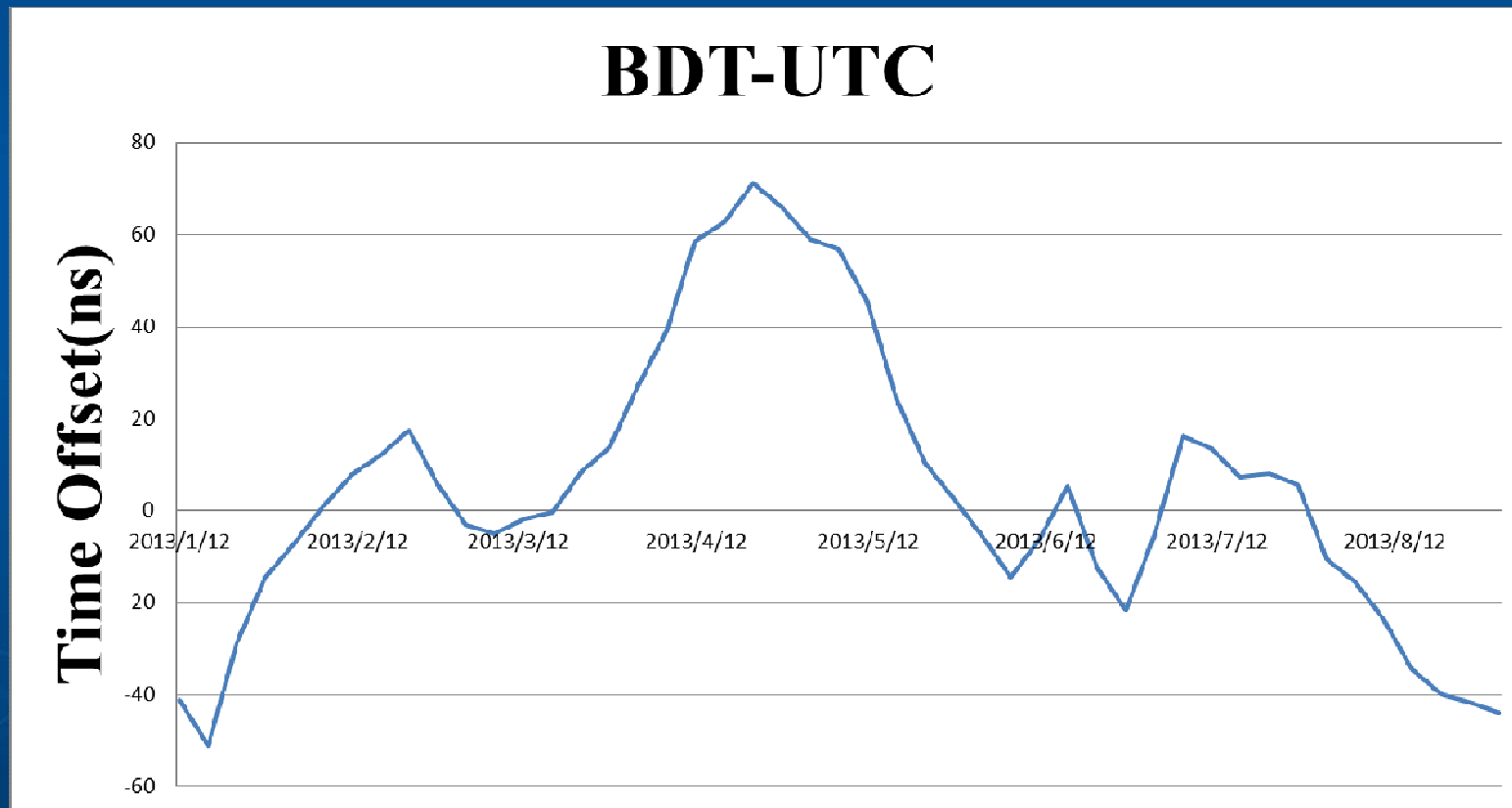

Through NTSC – UTC links, BDT – UTC was calculated



## 2、BDT Performance evaluation

### ■ Performance evaluation results of BDT relative to UTC(NTSC)

Measurement method	Frequency accuracy	Frequency stability		Time
GPS CV	8.89E-14	2.58E-14/d	1.20E-14/7d	Aug.-Sept.
BDS CV	7.67E-14	1.75E-14/d	1.08E-14/7d	Aug.-Sept.
TWSTFT	6.90 E-14	2.16 E-14/d	6.33E-15/7d	Aug.-Sept.

北斗



# 2 · BDT Performance evaluation

## ■ Performance evaluation results of BDT relative to UTC(NTSC)

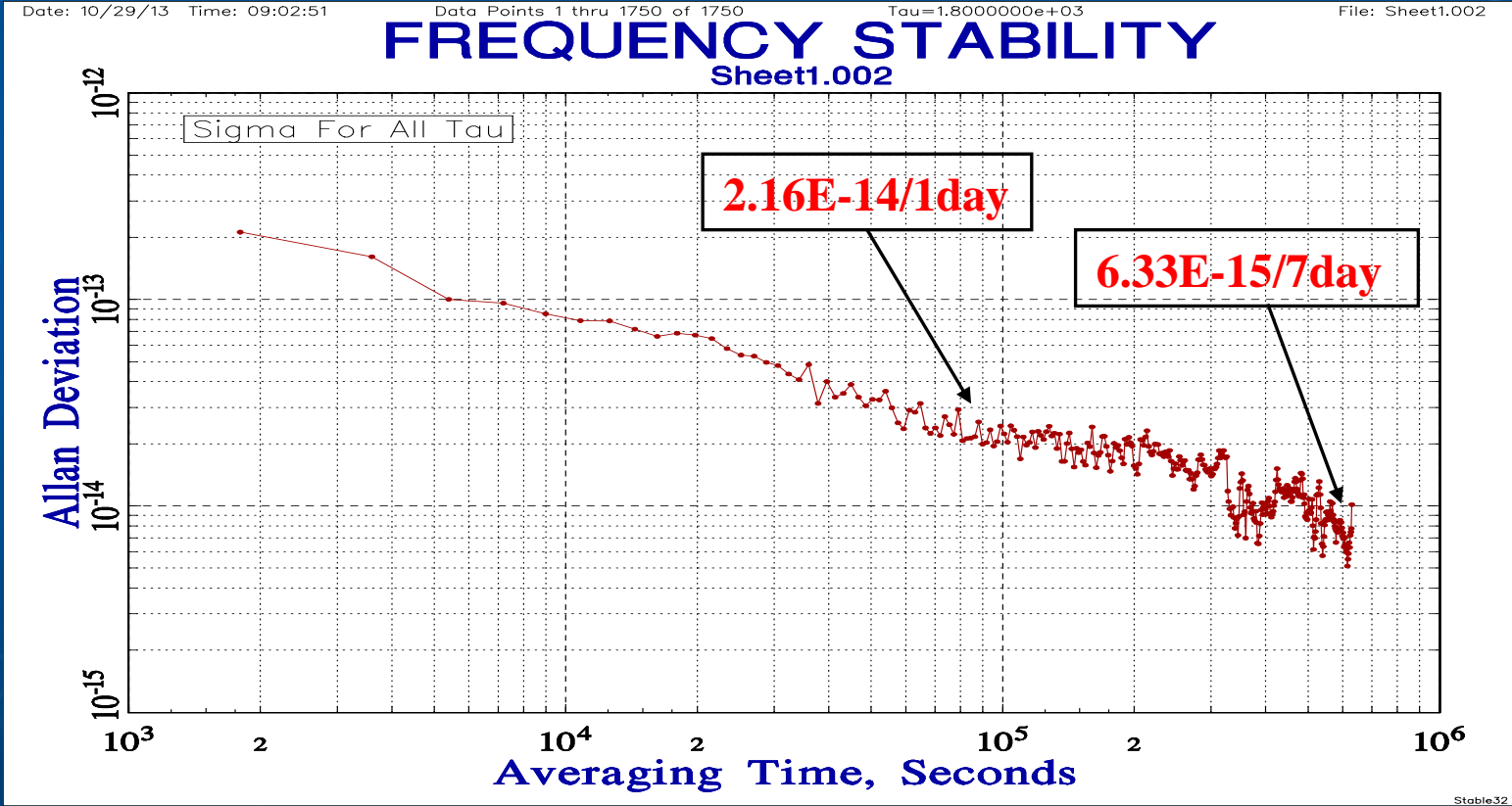

Frequency stability of BDT relative to UTC(NTSC) by C band TWSTFT



# 3、BDT/GPST time offset measurement

## ■ Measurement method

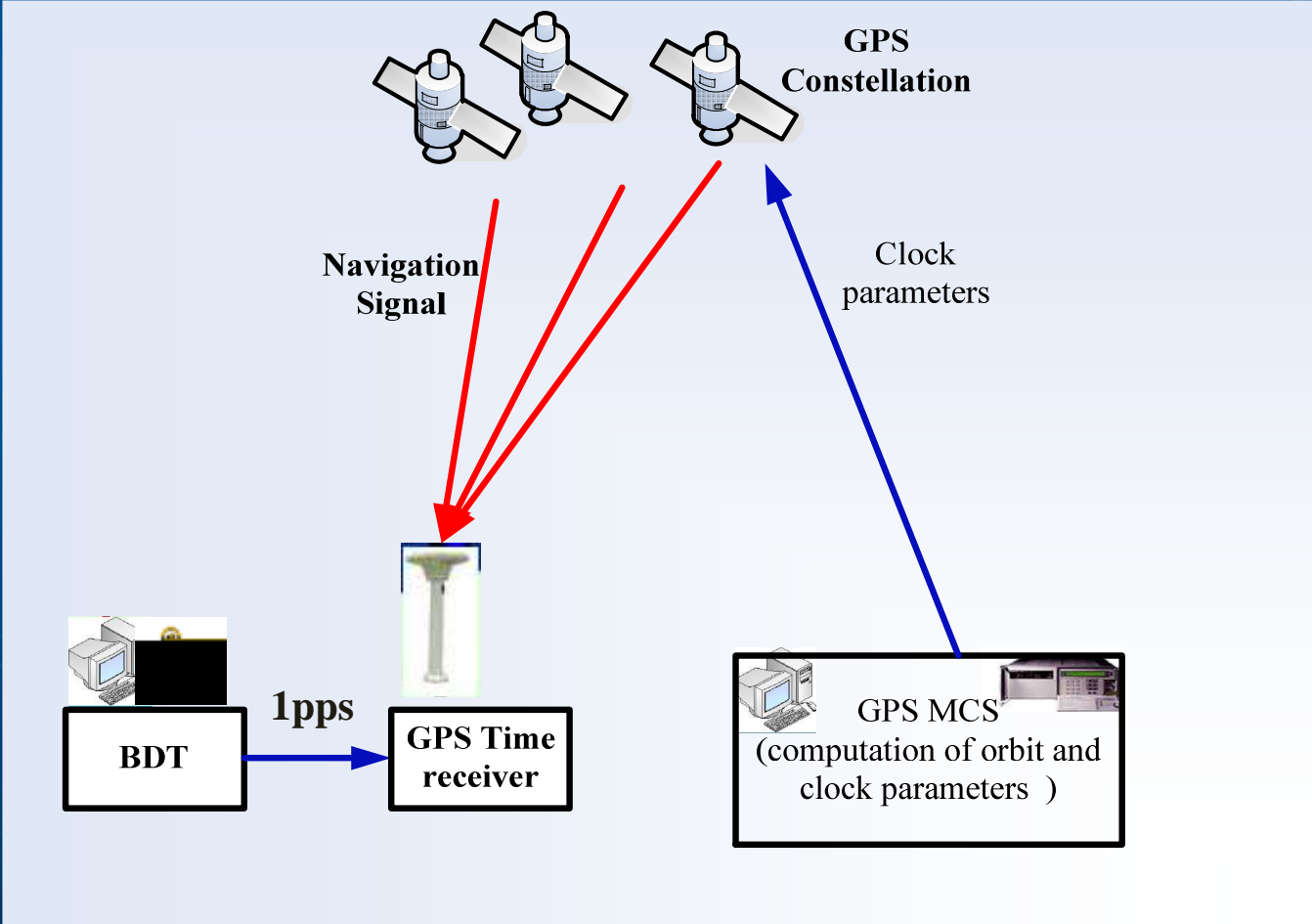

北斗



## 3、BDT/GPST time offset measurement

### ■ Time offset between BDT and GPST(12 Jan.-31 Aug.)

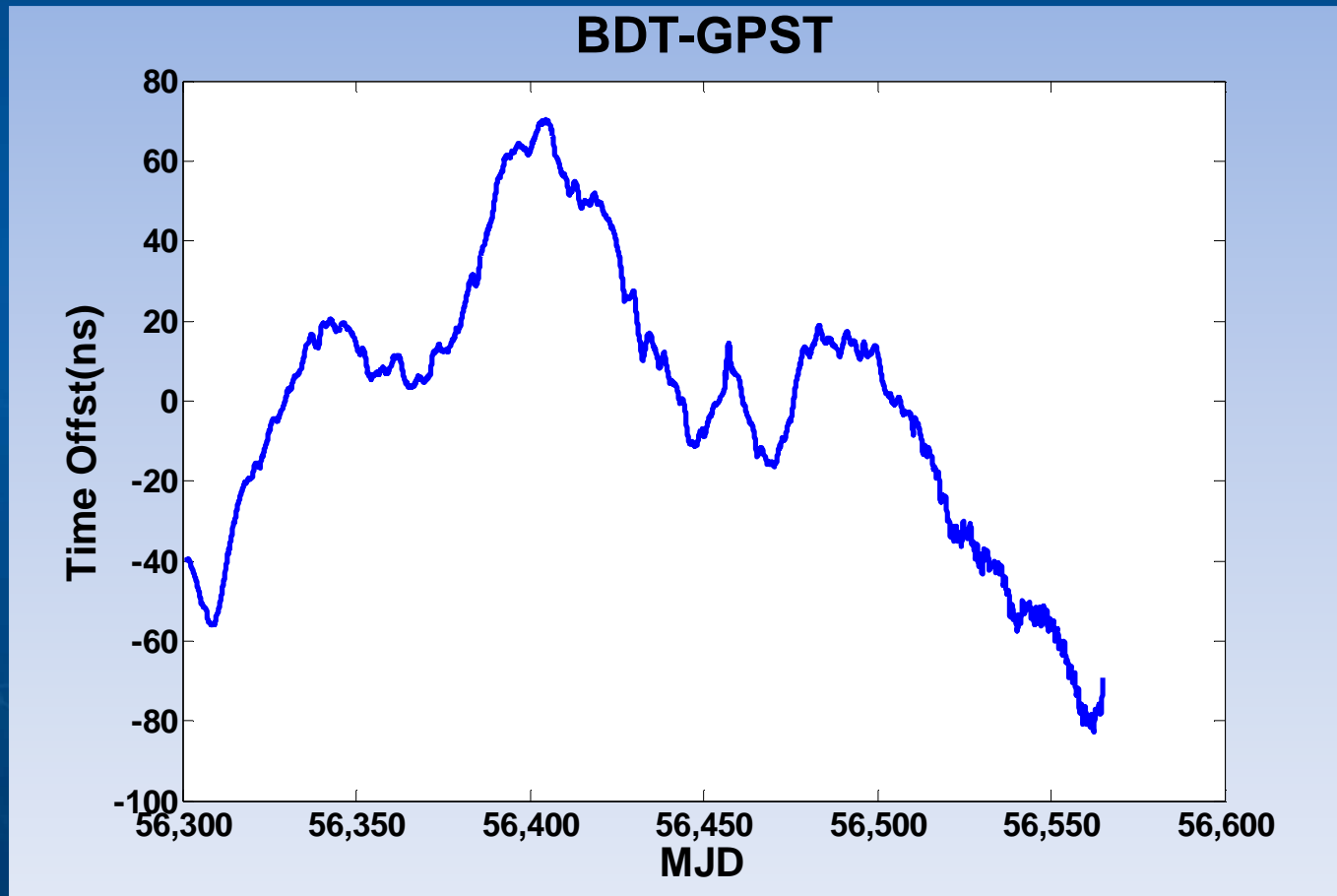



## 3、BDT/GPST time offset measurement

### ■ Time offset data modelling and prediction

- Analyzed data duration: 2 Oct. 2013 ~ 10 Oct. 2013 .
- Offset prediction algorithms based different polynomial models

1<sup>st</sup> model, 2<sup>nd</sup> model, 3<sup>rd</sup> model are tested

Model	1st order model	2nd order model	3rd order model
Data usage	Prediction: 1 day Based on: 3 days	Prediction: 1 day Based on: 3 days	Prediction: 1 day Based on: 3 days
	Prediction: 1 day Based on : 6 days	Prediction: 1 day Based on : 6 days	Prediction: 1 day Based on : 6 days



## 3、BDT/GPST time offset measurement

### ■ Detailed data of time offset measurement

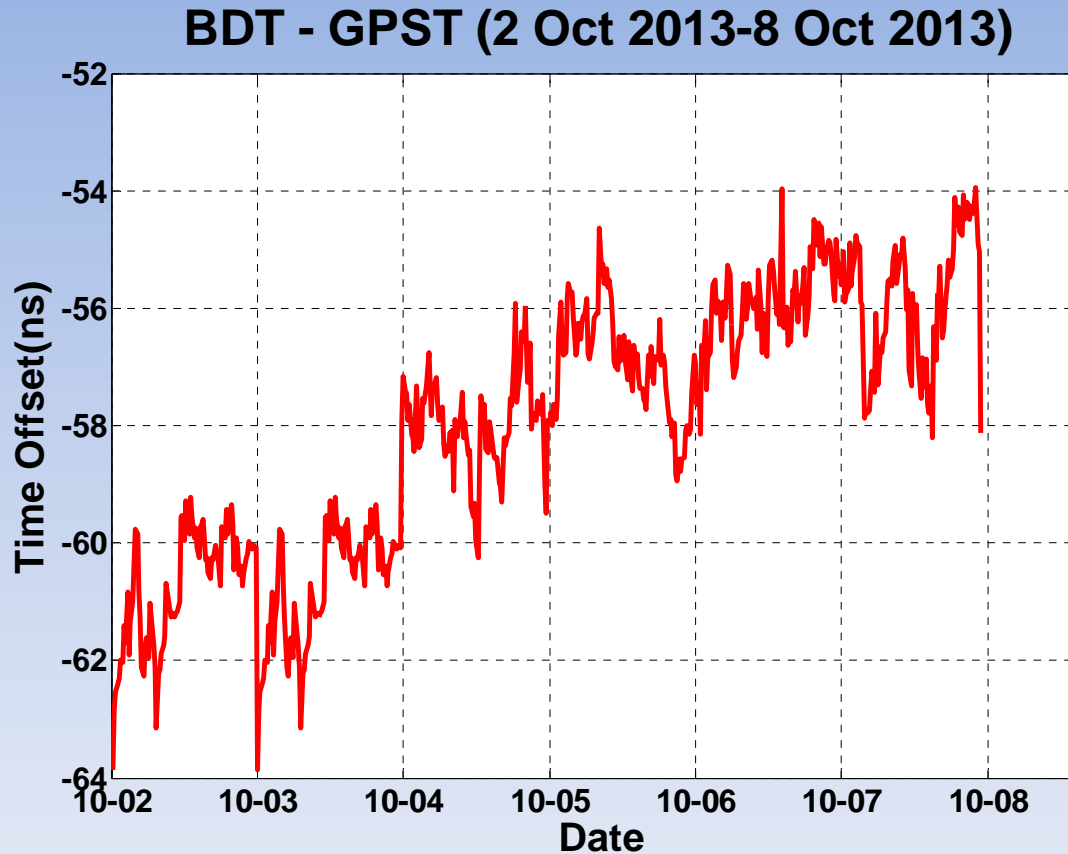

北斗

BDT-GPST





# 3、BDT/GPST time offset measurement

■ 1<sup>st</sup>、2<sup>nd</sup> and 3<sup>rd</sup> order ploynomial (three days → one day)

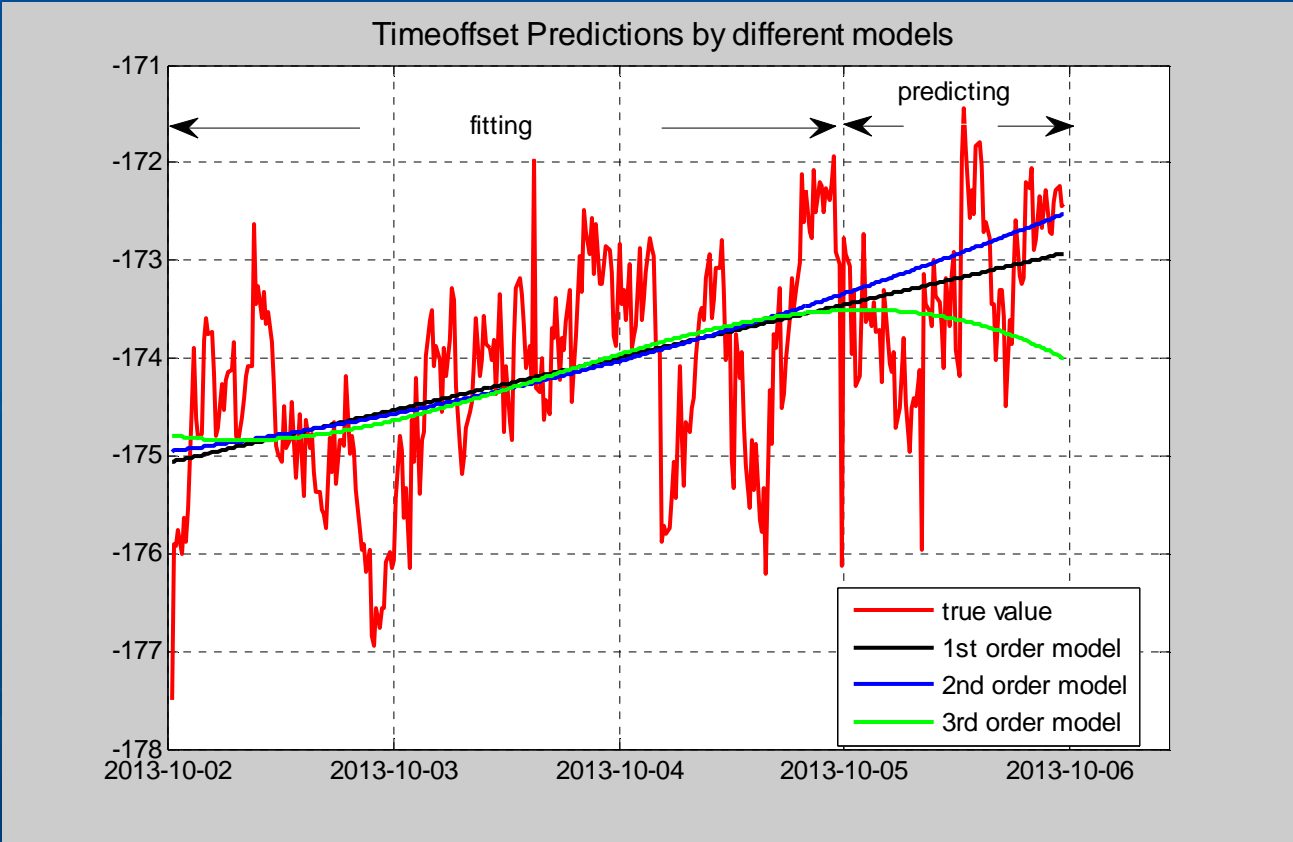

北斗



## 3、BDT/GPST time offset measurement

### ■ Prediction error comparison of three models

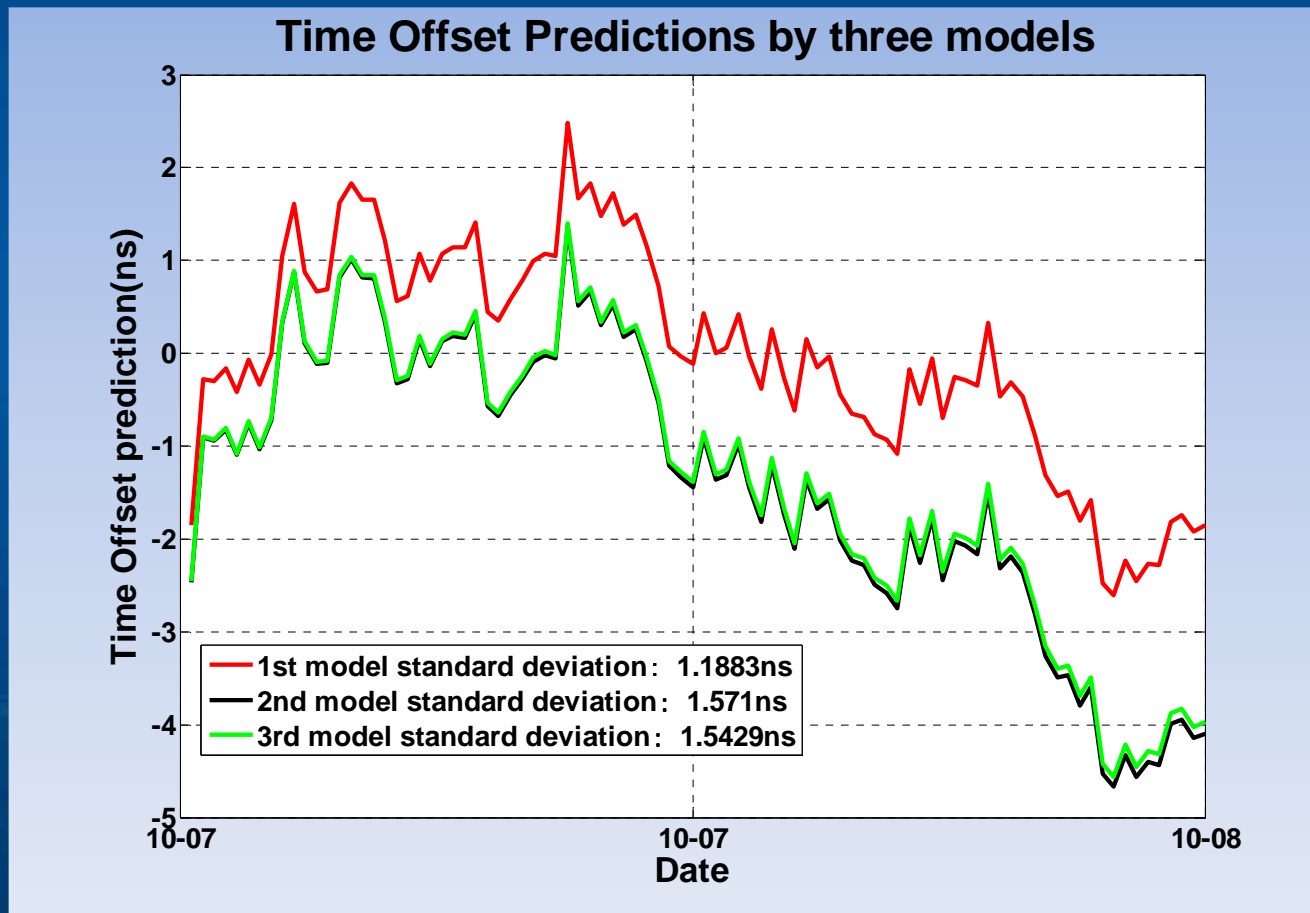

Predict one day using three days' data

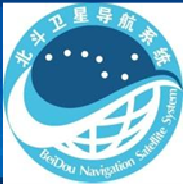

# 3、BDT/GPST time offset measurement

■ 1<sup>st</sup>、2<sup>nd</sup> and 3<sup>rd</sup> order polynomial (six days → one day)

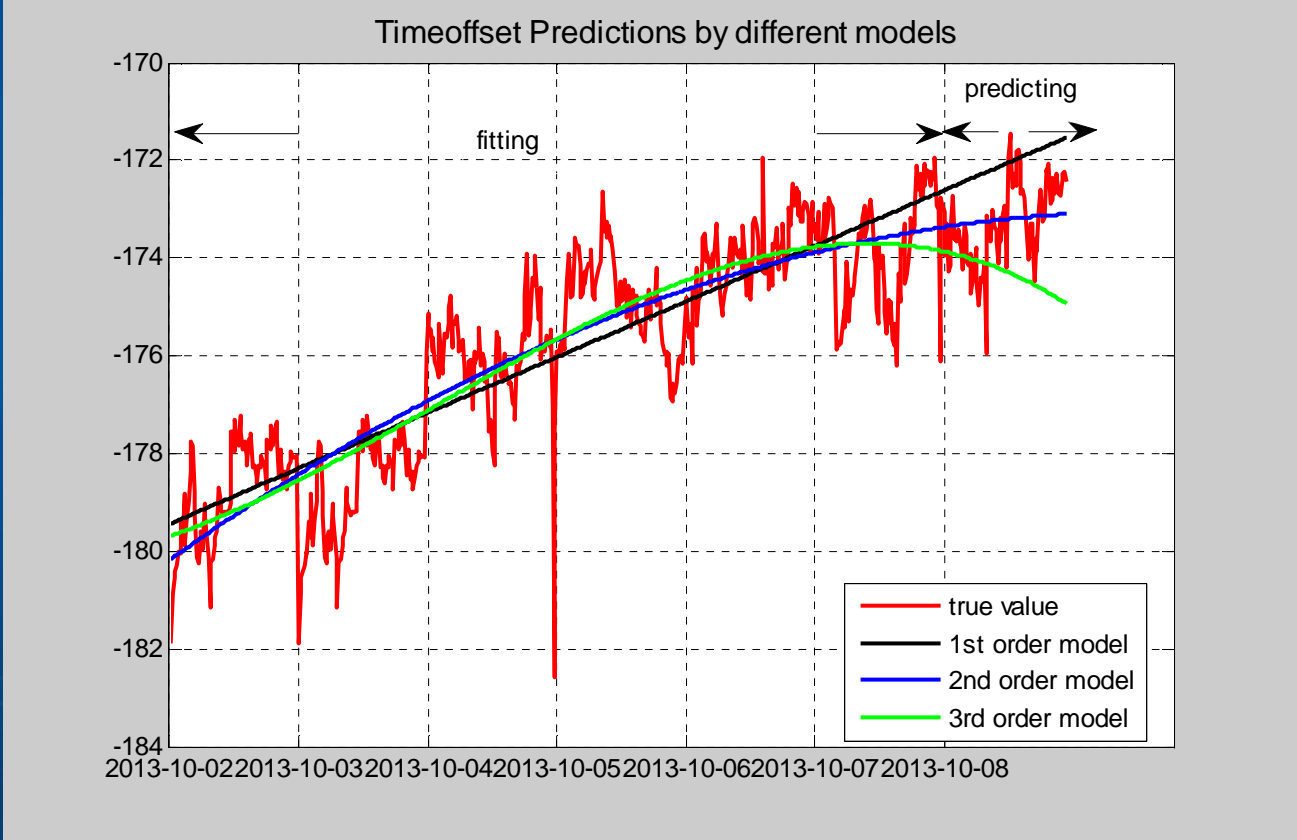

北斗



# 3、BDT/GPST time offset measurement

## ■ Prediction error comparison of three models

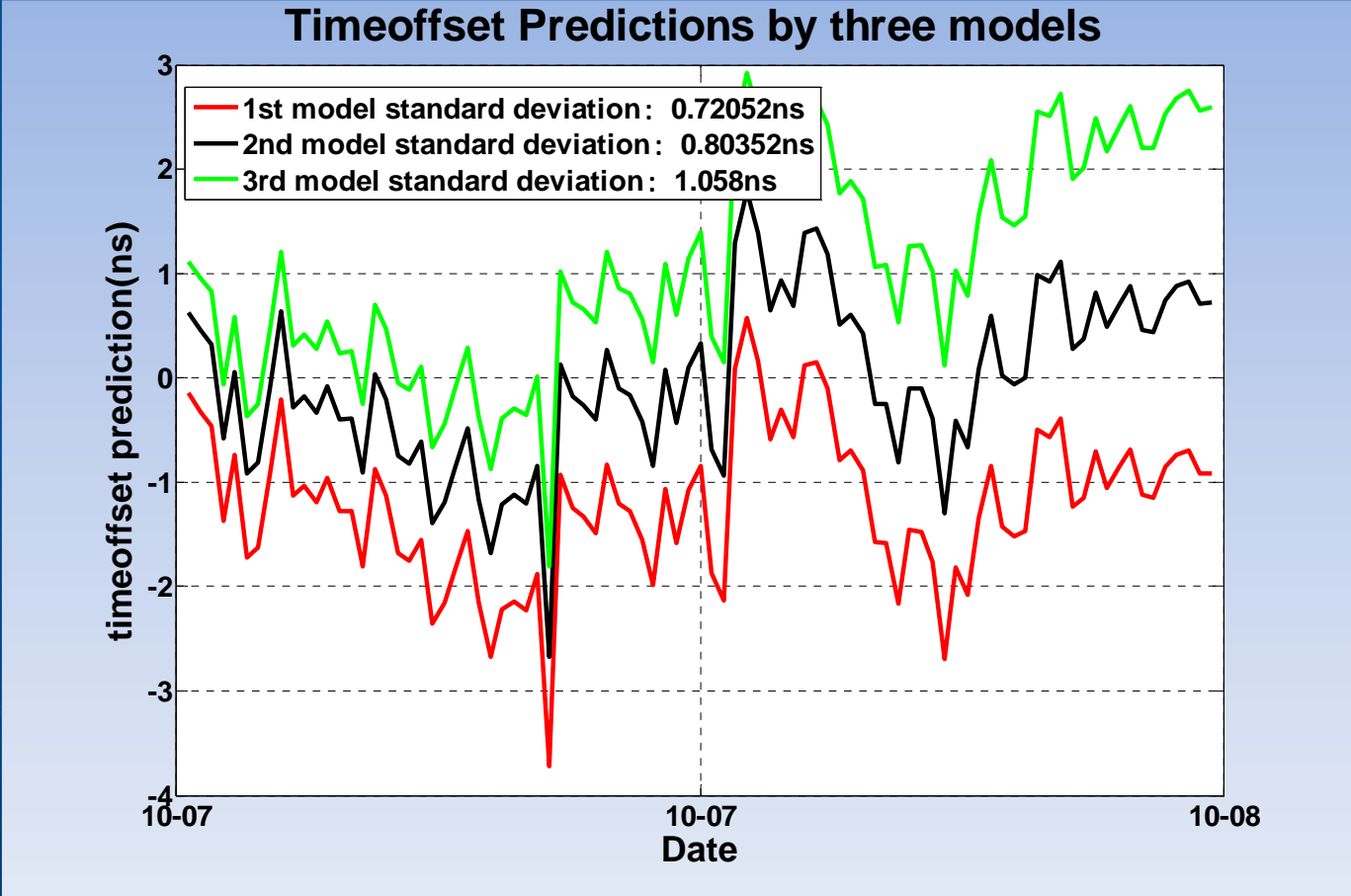

**Predict one day using six days' data**





## 3、BDT/GPST time offset measurement

### ■ Result comparison and analysis

Prediction error Prediction model	Std Dev (3 days' data => 1day)	Std Dev (6 days' data => 1day)
1st order poly	1.19	0.72
2nd order poly	1.57	0.80
3rd order poly	1.54	1.05



## 3、BDT/GPST time offset measurement

### ■ Moving average results comparison ( three days $\longrightarrow$ one day)

Prediction error Prediction model	Group1	Group2	Group3	Group4
1st order poly	1.19	1.08	0.58	1.18
2nd order poly	1.57	1.09	1.22	1.47
3rd order poly	1.54	1.26	2.23	1.08

- the longer the data used, the better the prediction precision. 6days' data is enough for the prediction in the above experiments.
- Low order(1-2order) polynomial could get good precision for modelling and prediction. Higher order(over 3 order) polynomial is not necessary .
- 1 ~ 2 ns precision could be got in BDT-GPST prediciton. If the system time stability or the receiver observation precision are improved, higher precision could be reached in future.



## 4、BD/GNSS time offset parameter template

- GNSS time offset is the basic of multiple system compatibility and interoperability.
- GPS and Galileo time offset (GGTO) parameters have been broadcasted in GPS/Galileo navigation message.
- The BDS/GNSS time offset parameters had been design and reserved in BDS navigation message, which include the time offset between BDT and GPST, GLONASST and GST.

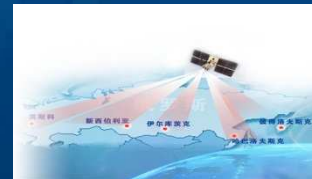



## 4、BDS/GNSS time offset parameter template

### ■ BDS Region System

Tab 5-18 Time parameters relative to Galileo time

Parameter	No. of Bits	Scale factor (LSB)	Units
$A_{0Gal}$	14*	0.1	ns
$A_{1Gal}$	16*	0.1	ns/s

\* Parameters so indicated are two's complement, with the sign bit (+ or -) occupying the MSB.

Tab 5-19 Time parameters relative to GLONASS time

Parameter	No. of Bits	Scale factor (LSB)	Units
$A_{0GLO}$	14*	0.1	ns
$A_{1GLO}$	16*	0.1	ns/s

\* Parameters so indicated are two's complement, with the sign bit (+ or -) occupying the MSB.

$$\text{where } \Delta t_{GPS} = A_{0GPS} + A_{1GPS} \times t_E;$$

$t_E$  is SOW in BDT computed by user.



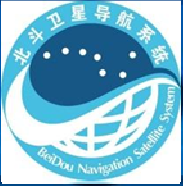

## 4、BDS/GNSS time offset parameter template

### ■ future design of BDS time offset parameter

Time offset parameters include BDT-GPST, BDT-GLONASST, BDT-GST.

The same formula of various GNSS time offset is adopted

$$\begin{aligned}
 \Delta t_{GNSS} &= \text{BDT} - t_{GNSS} \\
 &= A_{0BGTO} + A_{1BGTO} \left[ (t_E + 604800WN) - (t_{BGTO} + 604800WN_{BGTO}) \right] + \\
 &\quad A_{2BGTO} \left[ (t_E + 604800WN) - (t_{BGTO} + 604800WN_{BGTO}) \right]^2
 \end{aligned}$$

北斗



## 4、BDS/GNSS time offset parameter template

### ■ Parameters design

Parameter	Definition	Unit
$A_{0BGTO}$	Bias coefficient of BDT time scale relative to GNSS time scale	seconds
$A_{1BGTO}$	Drift coefficient of BDT time scale relative to GNSS time scale	sec/sec
$A_{2BGTO}$	Drift rate correction coefficient of BDT time scale relative to GNSS time scale	sec/sec <sup>2</sup>
$t_{BGTO}$	Time data reference Time of Week	seconds
$WN_{BGTO}$	Time data reference WEEK Number	weeks
$ID_{GNSS}$	GNSS Type ID (000=no data available, 001=GPS, 010=GLONASS,011=Galileo, 100 through 111=reserved for other system)	No unit



## 4、BD/GNSS time offset parameter template

### ■ GPS ICD 200D, GGTO parameters design

30.3.3.8.1 GPS/GNSS Time Offset Parameter Content. Message Type 35 provides SV clock correction parameters (ref. Section 30.3.3.2) and also, shall contain the parameters related to correlating GPS time with other GNSS time. Bits 155 through 157 of message type 35 shall identify the other GPS like navigation system to which the offset data applies. The three bits are defined as follows;

000 = no data available,

001 = Galileo,

010 = GLONASS,

011 through 111 = reserved for other systems.

30.3.3.8.2 GPS and GNSS Time. The GPS/GNSS-time relationship is given by,

$$t_{\text{GNSS}} = t_{\text{E}} - (A_{0\text{GGTO}} + A_{1\text{GGTO}} (t_{\text{E}} - t_{0\text{tGGTO}} + 604800 (WN - WN_{0\text{tGGTO}})) + A_{2\text{GGTO}} (t_{\text{E}} - t_{0\text{tGGTO}} + 604800 (WN - WN_{0\text{tGGTO}}))^2)$$

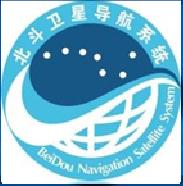

## 5、Summary

- a) **The time offset between BDT and UTC was kept within 100ns and the frequency stability of BDT is about  $3E-14/day$ .**
- b) **The time offset between BDT and GPST could be measured by GPS receiver and predicted precisely. The prediction error of 1day is about 1~2ns in the experiments.**
- c) **BGTO time offset parameters are design in BDS, which use the simple template similar to GGTO.**
- d) **The time offset parameters between BDS and other GNSS could be broadcasted in various navigation system. That is welcomed and benefit for all users.**



# Thank you!

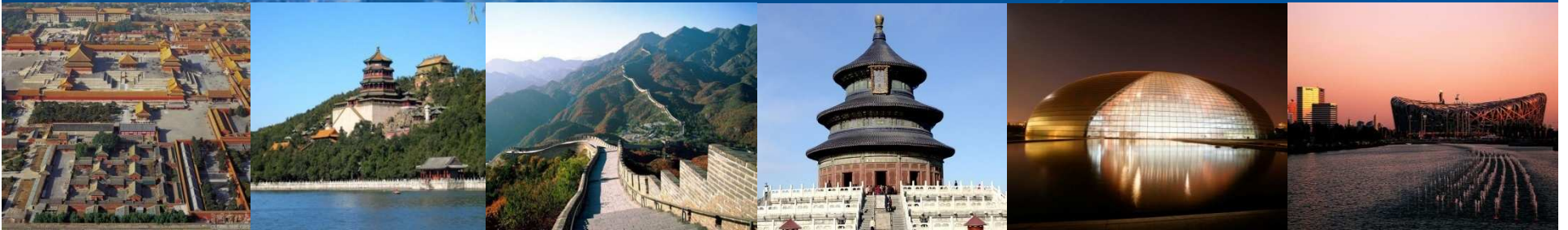

BEIDOU NAVIGATION SATELLITE SYSTEM