

# **Groundwater Manual for Small Water Systems**

**October 2016**



**Drinking Water Assistance Program  
The Montana Water Center  
Montana State University**

**Revised with the cooperation of the Montana Department of Environmental Quality  
Operator Certification Program**

# Purpose of the Manual

The “*Groundwater Manual for Small Water Systems*” is a publication the Montana Department of Environmental Quality, Public Water and Subdivisions Bureau (DEQ). It is intended to serve as an extensive source of information, references and as a certification study manual for groundwater system owners and operators in Montana.

The manual may also be used as an operation manual for many non-transient non-community and very small community public water supply systems serving fewer than 500 persons (systems in certification classification 4AB - see Appendix A for a table of certification classifications). These small water systems are operated by individuals who need to have a working knowledge of the public health, regulations, safety, infrastructure basics, and preventive maintenance aspects of a public water system. This manual attempts to cover these essential areas in sufficient detail to meet the needs of most very small public water supply systems. However, extensive coverage of distribution system repair, replacement or installation, and pump repair or electrical system troubleshooting is beyond the scope of this manual. Subject-specific references to more comprehensive operations and maintenance training manuals which address these items are provided in this text. Water system owners or operators supervising or performing these activities should refer to the more detailed references.

To avoid duplication of existing publications, this manual does not include specific monitoring or reporting requirements for drinking water regulations, operator certification requirements or minimum design standards for water works. Owners and operators of all public water systems should obtain copies of the appropriate version of these publications. Information on the appropriate publications is provided in the “Bibliography and Suggested References” section of this manual.

## Acknowledgements

Thanks are extended to the Water/Wastewater Operator Certification Program for financial support.

The original manual was first published in 1999.

Thanks to the Public Water and Subdivisions Bureau staff for updating, reviewing and editing the manual in 2016.

*To everyone, past and present, who has contributed to this manual:*

Your commitment to the residents of the State of Montana is evident by your relentless insistence on excellence in training and education of water and wastewater operators.

Thank you

Julie Allen

Water and Wastewater Operator Certification Technician

October 2016



## **Contents**

<b>Purpose of the Manual.....</b>	<b>i</b>
<b>Acknowledgments .....</b>	<b>ii</b>
<b>Chapter 1: Introduction to Public Water Supplies.....</b>	<b>1-1</b>
1.1 What is a Public Water Supply System?.....	1-1
1.2 Purpose of Public Water Supply Systems.....	1-1
1.3 Types of Public Water Supply Systems.....	1-2
1.4 Operator Certification Program .....	1-3
1.5 Operator Certification Requirements.....	1-4
1.6 Operator Need for Continuing Education.....	1-5
<b>Chapter 2: Public Water Supply System Regulations.....</b>	<b>2-1</b>
2.1 Introduction to Montana Public Water Supply System Regulations .....	2-1
2.2 Purpose of Public Water Supply System Regulations .....	2-2
2.3 Public Water Supply System Plan and Specification Review and Approval .....	2-3
2.4 Monitoring and Reporting.....	2-4
2.5 Monitoring Schedules .....	2-10
2.6 Sample Collection and Analysis .....	2-10
2.7 Public Notification.....	2-10
2.8 Public Water Supply System Annual Fees .....	2-11
2.9 Other State Requirements .....	2-11
<b>Chapter 3: Groundwater Basics.....</b>	<b>3-1</b>
3.1 The Hydrologic Cycle.....	3-1
3.2 Types of Aquifers .....	3-2
3.3 Groundwater Movement.....	3-4
3.4 Brief Chemistry of Water.....	3-7
<b>Chapter 4: Using Groundwater for Public Water Supply Systems .....</b>	<b>4-1</b>
4.1 Types of Groundwater Sources.....	4-1
4.2 Groundwater Contamination.....	4-3
4.3 Source Water Protection .....	4-6
<b>Chapter 5: Well Construction and Well Components .....</b>	<b>5-1</b>
5.1 Information and Records.....	5-2
5.2 Well Construction.....	5-3

## Table of Contents

5.3 Site Considerations and Location .....	5-7
5.4 Artesian Wells.....	5-9
5.5 Well Abandonment .....	5-10
5.6 Well Pumps and Other Appurtenances .....	5-10
5.7 Pressure Tanks .....	5-13
5.8 Well and Pump Maintenance .....	5-14
<b>Chapter 6: Treatment of Groundwater .....</b>	<b>6-1</b>
6.1 Overview of Disinfection.....	6-1
6.2 Chlorination .....	6-2
6.3 Ultra Violet Light (UV) .....	6-12
6.4 Other Disinfectants .....	6-13
6.5 Treatment for Common Chemical and Physical Contaminants .....	6-14
<b>Chapter 7: Distribution Systems .....</b>	<b>7-1</b>
7.1 System Components.....	7-1
7.2 System Pressure and Basic Hydraulics .....	7-9
7.3 Construction and Repair .....	7-13
7.4 Preventive Maintenance Program and Recordkeeping .....	7-15
<b>Chapter 8: Cross Connections and Backflow Prevention.....</b>	<b>8-1</b>
8.1 Cross Connections and Backflow Defined .....	8-1
8.2 Public Health Significance.....	8-2
8.3 Types of Cross-Connection Control .....	8-4
8.4 Types of Approved Backflow Preventers .....	8-4
8.5 General Installation Requirements.....	8-7
8.6 Thermal Expansion .....	8-8
8.7 Inspection & Testing.....	8-8
8.8 Typical Small System Cross Connections .....	8-8
8.9 Managing and Reporting Backflow Events .....	8-9
8.10 Cross Connection Control Plans.....	8-9
<b>Chapter 9: Safety for Small System Operators.....</b>	<b>9-1</b>
9.1 Elements of a Safety Program.....	9-1
9.2 Electrical Safety .....	9-2
9.3 Chemical Safety .....	9-2
9.4 Chemical Storage and Handling .....	9-3
9.5 Storage of Flammable Chemicals .....	9-4
9.6 Chlorine Safety .....	9-4
9.7 Traffic Control .....	9-5
9.8 Shoring and Trenching.....	9-5

***Table of Contents***

---

9.9 Confined Spaces.....	9-6
9.10 Fire Safety.....	9-7
9.11 First Aid.....	9-8
9.12 Personal Hygiene and Protective Clothing.....	9-8
9.13 Lifting.....	9-9
<b>Chapter 10: Emergency Planning.....</b>	<b>10-1</b>
10.1 Identification of Possible Disruption Threats.....	10-2
10.2 Source Protection.....	10-3
10.3 Security of Storage Facilities.....	10-4
10.4 Security of System Controls.....	10-5
10.5 Designation of an Emergency Coordinator.....	10-5
10.6 Equipment and Material Resources.....	10-5
10.7 Procedures to Shut Down the Well.....	10-6
10.8 Coordination Procedures.....	10-7
10.9 Procedures to Communicate with Water Users.....	10-7
10.10 Sources of Emergency Water.....	10-8
10.11 Disinfection and Resumption of Water Service.....	10-8
10.12 Funds.....	10-9
10.13 Contracts and Agreements.....	10-9
<b>Chapter 11: Water System Management.....</b>	<b>11-1</b>
11.1 Records Maintenance.....	11-1
11.2 Rate Structuring.....	11-2
11.3 Planning for the Future.....	11-3
11.4 Effective Communication.....	11-3
11.5 Consumer Confidence Reports.....	11-3
11.6 Public Notification.....	11-4
11.7 Relief Operator.....	11-4
11.8 Economics of Public Water Systems.....	11-4
11.9 Important Contacts for the Small Water System Operator.....	11-5
<b>Glossary of Terms.....</b>	<b>Glossary Page-1</b>
<b>Appendix.....</b>	<b>Appendix-1</b>
<b>Bibliography.....</b>	<b>Bibliography Page-1</b>
<b>Suggested References.....</b>	<b>Reference Page-1</b>
<b>Subject Index.....</b>	<b>Index Page-1</b>



## **Chapter 1 Introduction to Public Water Supplies**

### **1.1 What is a Public Water Supply System?**



A public water supply system provides piped water for human consumption to 15 or more service connections or an average of at least 25 individuals each day for at least 60 days each year. The system includes the source water intake (such as a well), treatment, storage, and distribution piping. This definition of a public water supply system is specified by law as part of the federal *Safe Drinking Water Act*. Human consumption of water includes drinking water and water used for cooking, food preparation, hand washing, bathrooms and bathing.

A private home served by its own well is not a public water supply system since it only provides water to a single service outlet. A mobile home park with 15 or more service connections is a public water supply system.

A bar, restaurant or motel served by its own well is usually a public water supply system since it serves an average of 25 or more people each day, even though they may not be the same people every day. Schools and industries that have their own well are also public water supply systems if they have an average of 25 or more people at the facility each day.

Seasonal establishments such as campgrounds and ski areas are also public water supply systems if they are open at least 60 days (not necessarily consecutive days) each year and serve an average of at least 25 people each day.

### **1.2 Purpose of Public Water Supply Systems**

The main purpose of public water supply systems is to provide water which is safe for human consumption. Other important purposes are to provide an adequate quantity of water of acceptable taste, odor and appearance; and often to meet limited irrigation needs and fire protection. Providing water service places owners and operators of water systems under an ethical and legal obligation to meet these needs.

Most people in the United States take safe, inexpensive drinking water for granted. We assume all water that comes from a tap is okay to drink, whether in a restroom, a gas station or a friend's home. Few of us realize the planning, monitoring, repair and maintenance required to obtain and protect adequate amounts of safe water.

The federal government, through the Environmental Protection Agency (EPA), and individual states have established minimum requirements for water quality that must be met by public water

supply systems. These requirements are meant to protect the public from contaminants which may cause *acute* or *chronic* health effects.

Contaminants that may have an immediate impact on health after drinking small amounts of water must be dealt with in all public water systems. These contaminants cause *acute health effects*. Examples are disease-causing organisms and nitrates.



## ***Chapter 1: Introduction to Public Water Supplies***

---

Contaminants that cause health effects if consumed over long periods of time must be dealt with in systems where the same residential or non-residential consumers have access to the water on a long-term basis. These contaminants cause ***chronic health effects***. Examples include cancer-causing chemicals and chemicals affecting the nervous system or kidneys.

The provision of an adequate quantity of water is addressed by properly sizing the source, pumping equipment, treatment, storage and piping to meet a reasonable demand for water created by all intended purposes.

Taste, odor and color are addressed through recommended maximum levels of certain contaminants that may make water unappealing. Aesthetic water quality is secondary water standards and not always monitored or regulated.

### **1.3 Types of Public Water Supply Systems**

Public water supply systems fit into three categories. The categories are based on whether a system:

- 1) serves residences,
- 2) serves the same non-residents for most of each year, or
- 3) serves individuals who would only consume the water on a short-term basis.

The categories have been specified to relate the public health effects of potential contaminants to the risk of exposure to those contaminants. That is, if water from a particular system is consumed by the same individuals over a long period of time, then that system must ensure exposure to contaminants causing both acute and chronic health effects are addressed. If a system serves consumers only for a short period of time, contaminants causing acute health effects must be addressed.

The three categories of public water supply systems are:

- Community,
- Non-Transient Non-Community, and
- Transient Non-Community systems.

***Community Water Systems*** serve residents. There must be 15 or more service connections on the same system or at least 25 residents served by the system. This category includes mobile home parks, subdivisions, water user associations, water districts, cities and towns, and some apartment buildings. Because people usually consume large amounts of water at their residences for many years, these systems must be concerned with contaminants having both acute and chronic health effects.

***Non-Transient Non-Community Water Systems*** serve schools and businesses serving the same non-resident persons each day for more than six months per year. These systems must also be concerned with contaminants having both acute and chronic health effects.

***Transient Non-Community Water Systems*** serve non-residents who do not work or attend school at the same facility for at least six months in a row. This category covers bars, restaurants, rest stops and campgrounds, to name a few.

Transient non-community systems must be concerned with contaminants that may cause acute health effects by consuming very little water. They are not required to monitor and control contaminants that may cause long-term health effects since people are expected to consume the water for short periods of time.

### **1.4 Operator Certification Program**

Since 1967, Montana has required all community water systems to have a certified operator in responsible charge. On July 1, 1998, all non-transient non-community water systems were required to have a certified operator. These requirements are now federal mandates and are not unique to Montana.

Certified operators play a crucial role in protecting the health and welfare of Montana citizens, which can be jeopardized if persons not properly qualified are allowed to operate water supply systems.

There are many disease-causing organisms and chemicals that may enter a system through the water source or through problems in the distribution system. Most contaminants cannot be seen or smelled, so proper system maintenance and monitoring is necessary to ensure the protection of public health. Water users expect a safe and adequate water supply. They rely on the system operator to notify them if problems occur.

Protection of the water system is also an important job of the certified operator. Large amounts of money are required to design and install water system sources, treatment, distribution piping, valves and other components. Improper operation and maintenance of pumps, storage tanks and treatment systems can result in their early failure, and expensive repair or replacement.

The need for responsible water system operators is enormous. Successful water system operations require someone with skill, knowledge and experience in operating, maintaining and troubleshooting water sources, treatment, and distribution systems. Even if the operator will not be the one to repair or replace broken equipment, he/she must be able to recognize potential problems and take action to correct problems.

Montana's operator certification program is a fee-based program implemented by the Montana Department of Environmental Quality Water and Wastewater Operators' Certification Program. In addition to providing applications and study material to prospective operators, the program administers the examination process, evaluates experience and education requirements, evaluates training events for continuing education credit approval, and tracks continuing education credits obtained by each operator.

A Water and Wastewater Operators' Advisory Council made up of water and wastewater system professionals from within Montana assists the program in policy development and addressing operator concerns. A list of the current Water and Wastewater Operators' Advisory Council members may be obtained by contacting the certification program.

The "*Montana Operator Code of Ethics*" reflects the responsibilities of an operator:

*"Using my best judgment and operating skills, I will always work to protect the public health, to ensure good service, to protect public property and the environment, by applying my skills in operating water and wastewater system equipment, by properly and accurately completing required records, following and complying with state and federal rules and regulations, continuing my education in my field, and working with management to establish distinct and safe operating policies for the public utilities for which I am entrusted."*

## **1.5 Operator Certification Requirements**

To become a certified operator, an individual must:

- 1) submit an application and pay an application fee and an examination fee;
- 2) pass a written examination specific for the size and type of system to be operated;
- 3) meet minimum experience requirements; and
- 4) have at least a high school diploma or equivalent.

## ***Chapter 1: Introduction to Public Water Supplies***

---

Maintaining certification requires:

- 1) annual renewal of the certificate;
- 2) meeting continuing education requirements every two years; and
- 3) continued employment as an operator in a public water system of the same certification classification.

Montana's water operator certification classifications are based on type of source, population served and type of treatment used by the public water supply system. Refer to Appendix A of this manual for a classification table.

Operators are required to notify the Water and Wastewater Certification Program in the event they are no longer the operator for a specific system. This is to emphasize the importance of a system having a certified operator at all times.

### **1.6 Operator Need for Continuing Education**

Our understanding of drinking water quality and chemical and biological contaminants in water is changing almost daily. Better laboratory methods to find small amounts of chemicals and improvements in diagnosing and tracking disease, more clearly define water that is truly safe to consume.

Along with increased knowledge of health threats which may be in drinking water, we have also increased our ability to prevent their occurrence, and to detect and remove them. Special sample collection methods, monitoring schedules and treatment options exist for a variety of possible contaminants.

All certified operators, as well as system owners and managers, have a responsibility to keep up with changes in monitoring and reporting requirements. It is important they are also aware of new information on water quality and treatment.

Montana requires all certified operators to obtain ***continuing education credits (CECs)***. Continuing education is essential to staying abreast of water supply, treatment, maintenance, operation and monitoring information.

The amount of continuing education that must be obtained depends on the certification classification. Information on specific requirements for your type of certification may be obtained by contacting the DEQ Water and Wastewater Operator Certification Program.



## **Chapter 2: Public Water Supply System Regulations**

Regulations affecting public water supply systems cover a wide range of subjects. The following are the main areas which concern drinking water:

- Monitoring and reporting requirements dealing with water quality, treatment, and public communication;
- Operator certification requirements pertaining to individuals in responsible charge of a water system;
- Minimum design standards and the plan review and approval process ensuring water system components are adequately sized and properly installed; and
- Other regulations address such issues as safety during system repair or construction, fire codes, and cross-connection control programs.

General information on each of these subjects are presented in this chapter. Some items are covered in more detail later in the manual.

Specific monitoring and reporting requirements have intentionally been left out of this manual because they differ by system size and, in some cases, by specific system. Regulatory summaries and system-specific monitoring schedules should be obtained from the Public Water Supply Program, Montana Department of Environmental Quality (DEQ).

### **2.1 Introduction to Montana Public Water Supply System Regulations**

Montana has had a public water supply program since 1907, when outbreaks of waterborne disease and associated deaths moved the legislature to pass the first law regulating public water supplies.

Prior to 1970, protection of drinking water on a national level was the responsibility of the United States Public Health Service (PHS) which established standards for the quality of water used in interstate commerce.

In 1974, the federal government passed the *Safe Drinking Water Act (SDWA)*. This act established national drinking water regulations to protect public health. The regulations addressed not only public health problems resulting from drinking water, but also health problems resulting from skin contact with the water and inhaling contaminant vapors released from the water.

Individual states, like Montana, are expected to carry out and enforce these regulations for public water supply systems. This role of implementation and enforcement by states is called *primacy*, for 'primary enforcement authority.' Montana must adopt regulations no less stringent than the federal requirements to maintain the role of primacy agency.

The DEQ is responsible for implementing the Safe Drinking Water Act in Montana. The EPA oversees the state program to ensure minimum requirements are met.

The SDWA must be reauthorized by Congress every nine years. When Congress evaluates the adequacy of the Act during reauthorization, changes or amendments to the Act are often made.

The 1986 Amendments to the SDWA significantly increased the number of contaminants public water supply systems must monitor. It tightened the requirements for systems which use *surface water*, and defined public notification requirements when monitoring is not performed or when a contaminant exceeds the maximum allowable limit.

The 1996 Amendments to the SDWA added some flexibility for state implementation of the federal requirements and included new items for certified operators and system capacity. '*Capacity*' as it is used here,

## ***Chapter 2: Public Water Supply System Regulations***

---

refers to the financial, managerial, and technical abilities of a public water supply system. It is also sometimes referred to as system ‘*viability*’.

### **2.2 Purpose of Public Water Supply System Regulations**

Regulations governing public water supply systems serve two purposes. The primary purpose is to ensure reasonable protection of the health of people who consume the water (referred to as “protection of the public health”). A secondary benefit is that regulations help ensure protection of the investment dollars spent on construction of the public water supply system.

Public health protection is obtained by:

- 1) setting ***maximum contaminant levels (MCL's)*** for certain contaminants which may not be exceeded by a public water supply system;
- 2) ensuring monitoring for contaminants is done in a reasonable fashion; and,
- 3) requiring treatment be installed to remove contaminants to below levels specified by their MCL.

The MCL for each contaminant is the enforceable drinking water standard, or ***primary standard***. It is based on a ***maximum contaminant level goal (MCLG)***, a level below which no adverse health effects are expected to occur from drinking contaminated water. MCL's are set as close to the MCLG's as possible, taking costs and technology into consideration.

Some contaminants, for which analytical methods are poor or impractical, have minimum treatment requirements instead of MCL's. Examples of treatment technique requirements include filtration of surface water sources and corrosion control.

The “***Multiple Barrier Concept***” of public health protection incorporates several independent steps to provide public health protection. The theory behind this concept is the more barriers between a contaminant and the consumer, the more likely an isolated failure in one of the steps will not result in adverse public health effects.

For a public water supply system using groundwater, steps in the multiple barrier concept include:

- selecting the best source or source location;
- developing and implementing a source water protection plan;
- providing adequate treatment to remove or eliminate contaminants;
- monitoring water quality to check the effectiveness of treatment or the occurrence of contaminants (there are also often multiple barriers within treatment processes);
- providing sanitary surveys to identify deficiencies which might impact water quality or service; and
- reporting to the public any contamination events, monitoring failures, or water treatment deficiencies.

Proper design and construction of a public water supply system has a critical role in public health protection. It is also an expensive process regardless of the size of the system. Investment dollars are protected if the system is engineered, constructed, operated and managed so that it is able to provide safe water for as long as possible.

Monitoring water quality indicates if part of the system has failed, is leaking or is exposed to conditions which may shorten its useful life. Conditions which may affect the life of pipe include very hard water which might plug pipes, or corrosive water which ‘eats away’ at the interior of pipes and tanks.

### **2.3 Public Water Supply System Plan and Specification Review and Approval**

All public water supply systems must have any alterations or extensions of their water system approved by DEQ prior to initiation of any construction. This includes addition of any treatment systems, main extensions, or pipe replacement. Approval is not needed for repair or replacement of system components, such as pumps or pressure tanks, as long as the replacement parts are exactly the same as the original parts.

## ***Chapter 2: Public Water Supply System Regulations***

---

Community public water supply systems must have their plans and specifications submitted by a professional engineer licensed by the State of Montana. Non-transient non-community and transient non-community water systems only need to use a licensed professional engineer if, in the opinion of DEQ, the complexity of the project warrants one or if treatment components are being installed.

Plans and specifications submitted to DEQ are compared to *minimum design standards* specified in Circular DEQ-1 (community systems) or Circular DEQ-3 (non-community systems). Consulting engineers usually submit plans for community systems illustrating compliance with Circular DEQ-1. Likewise, non-community water systems must also show their projects meet minimum design standards of Circular DEQ-3 for small public water supply systems. Copies of the minimum standards are available from DEQ.

Several items are evaluated in the plan and specification review process. Minimum standards ensure new sources of water are located properly to minimize the potential for contamination, that pipe used is of adequate strength and is not going to leach toxic chemicals, that treatment is adequate to address the problem for which it is needed, and that components are sized properly.

Another standard of particular importance ensures well construction is performed by a *licensed water well driller* for any new water well. Licensed drillers are required to meet minimum standards for the depth of grout, casing height above ground, etc. These items are important to the protection of the quality of the source water and are discussed in more detail in Chapter 5: *Well Construction and Well Components*. Public Water Supply rules and design standards are in addition to the well construction standards specified in the well driller rules and may be more stringent than those rules.

Systems which do not conform to the plan review and approval process may install unnecessary treatment which ‘sounded good’ when talking to the salesman, but may not be useful for the problem at hand. Others may install poor-quality pipe which frequently breaks and leaks.

Engineers and other professional staff at DEQ are available to answer questions on treatment options and the plan review and approval process. They will also determine if a professional engineer is required for the project. DEQ staff is very aware of the need for prompt reviews for water systems.

Payment for the reviews was mandated by the Montana Legislature. The amount of the fee is determined by the type of project planned. A copy of the fee schedule is available from DEQ.

### **2.4 Monitoring and Reporting**

Monitoring for possible contaminants is the process of sampling the water and submitting the samples to an appropriate certified laboratory for analysis. Reporting refers to either submitting results of analyses to DEQ or submitting proof of other action, such as issuing a required public notice. Details on monitoring and reporting requirements are not given here because these vary from system to system. Basic monitoring and reporting requirements can be found at <http://deq.mt.gov/wqinfo/pws/reports.mcp>. This section provides a discussion of the purpose and an overview of the major monitoring and reporting requirements.

#### ***2.4.1 Microbiological Quality Monitoring and Reporting***

Disease-causing organisms which can be in public water supply systems are numerous. There are many bacteria, viruses and protozoans known to be able to cause disease if ingested. As a group, they are often referred to as microorganisms or simply “microbes”, since they are very small and cannot be seen without a microscope.

“Microbiological quality” refers to the presence or absence of microbes in the water. Some common types of microbes you may be familiar with include organisms that cause cholera (a bacteria), hepatitis (a virus), and giardiasis (a protozoan).

## ***Chapter 2: Public Water Supply System Regulations***

---

Analytical methods do not exist to allow monitoring for every individual disease-causing agent that might contaminate a public water supply system. Instead, we rely on monitoring for ***indicator organisms*** which indicate water may be contaminated. The indicator organisms used for all water systems is a group called ***Coliform Bacteria***.

Coliform bacteria, while not typically disease-producers themselves, are often associated with ***pathogenic*** (disease-producing) organisms. They are an index of the degree of microbiological safety of the water. They commonly come from soil or the fecal material (stools or manure) of warm-blooded animals. Coliforms survive longer in the environment than most disease-causing organisms, making them useful in determining if a contamination event might have occurred.

Routine monitoring for coliform organisms is directed at looking for members of the ***Coliform*** group of bacteria. These bacteria have special characteristics when grown in the laboratory under specific conditions. If coliforms are found in the water, the bacteria are further analyzed to determine if they are ***fecal coliforms***. Fecal coliforms are a specific subgroup of coliforms which grow only at body temperature of warm-blooded animals. They are used to determine if fecal contamination of water has occurred.

Microbiological quality monitoring has three important components:

- 1) scheduled routine monitoring,
- 2) repeat sample collection, and
- 3) use of a sample site plan to be sure routine and repeat monitoring provide as much information as possible.

***Routine Coliform Monitoring*** is performed on a routine basis. Requirements for the number of samples to be collected each month are based on the population served by the public water supply system and whether the system operates seasonally, such as campgrounds and ski areas.

Every public water supply system must collect routine samples. The locations where routine samples are collected must be rotated to other places designated on the sample site plan each time so the entire distribution system (or building if the system is in a *single building*) is covered.

***Repeat Samples*** are collected if a routine sample comes back with an unsatisfactory result - this means coliform bacteria were detected. These unsatisfactory samples are often referred to as “positive”. The number of repeat samples that must be collected is determined by the required number of routine samples.

Repeat samples are intended to confirm the occurrence of a contamination event. The public water supply system must collect repeat samples within 24 hours of being notified the routine sample was unsatisfactory and *before* any adjustment is made to the system. The intent is to determine if water already in the public water supply system is contaminated and *not* mask a contamination problem by adding a disinfectant to the system before determining if contaminated water may already have reached consumers.

***Sample Site Plans*** are prepared by the owner or operator of a public water supply system. They are simple maps of the water source, storage and distribution system. They should include areas of individual ***pressure zones***. The site plans are used to identify where routine and repeat samples will be collected. Specific numbers are assigned to each site and used on the monitoring report forms sent to the laboratory with the water samples.

Copies of sample site plans for community public water supply systems must be submitted to DEQ. Sample site plans for non-community systems must be available at the system. Sample site plans are extremely helpful when

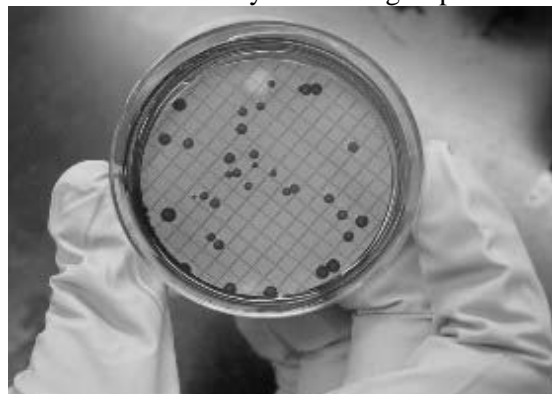

Colonies of fecal coliform bacteria filtered from water samples and grown on mFC nutrient agar are indicators of fecal contamination of the water.  
Photo by Susan Boyer

## ***Chapter 2: Public Water Supply System Regulations***

---

discussing microbiological monitoring results with DEQ staff, identifying chronic problem areas, and conducting system sanitary surveys and other inspections.

Bacteria are found nearly everywhere on Earth. They are on our skin, in our intestines and on every plant and animal. They are important components of soil. However, not every bacterial organism causes disease.

**Special samples** may be collected at any time on water that is not being served to consumers to investigate system microbiological quality. They are useful for checking on potential problem areas or to verify a new or repaired main has been adequately disinfected and is ready to return to service. Special samples can be collected in addition to routine or replacement monitoring samples. Special samples must be clearly marked as such on the sample report form submitted with the water sample to the laboratory. Special samples *may* be used by DEQ to calculate compliance if they are collected from water being served to the public. (If the water is being served to the public, this is not *technically* a special sample.)

Results of **all** microbiological quality samples must be submitted to DEQ. Laboratories certified to perform coliform analyses are required to submit a copy of the results to DEQ. However, in some cases results are not received at DEQ. It is ultimately the responsibility of the owner or operator to ensure that DEQ receives a copy of all results. If a copy cannot be found, it must be assumed sampling did not occur and the system will receive a notice for failing to monitor. Samples must be received by a certified lab within 24 hours of being taken. The results of the samples must be to DEQ by the 10<sup>th</sup> of the month following the sample month.

This illustrates how important it is to keep copies of all laboratory results. In Montana, copies of all chemical and microbiological monitoring results must be kept for a minimum of *10 years*.

### ***2.4.2 Chemical Contaminant Monitoring and Reporting***

Community and non-transient non-community public water supply systems must monitor for over 100 different possible chemical contaminants. They range from inorganic chemical contaminants like silver and cyanide, to gasoline derivatives such as benzene, or solvents used in dry-cleaning. Health effects caused by various chemical contaminants include kidney and liver problems, cancer, and nervous system disorders.

*All* public water supply systems must monitor for nitrates and nitrites unless their water is purchased. These chemicals can cause a serious disorder called ***methemoglobinemia***, or “blue baby syndrome”. This is a condition in which blood is unable to transmit oxygen to the body, so the body appears to be blue. It is a serious threat to infants and pregnant mothers. Montana has areas of high levels of nitrate in groundwater. Several public water supply systems must treat their source water to remove nitrates.

Chemical contaminants differ from biological contaminants in that they can each be identified using specific test methods. Sometimes general scans can be made of a water sample to see if any of a group of chemical contaminants are present. If the scan shows a contaminant is present, additional analyses are performed to identify and quantify the chemical.

Chemical contaminants which cause acute health effects are monitored more frequently, such as nitrates which are typically required to be monitored annually. Chemicals causing chronic health effects may be monitored only once every few years.

Chemical contaminant monitoring requirements differ for each system based on the system's monitoring history and vulnerability. Please refer to Section 2.5 *Monitoring Schedules* and the regulation summaries available from DEQ for specific information.

It is the responsibility of the system owner/operator to ensure that copies of all results are forwarded to DEQ.



### ***2.4.3 Chlorine Residual Monitoring and Reporting***

In Montana, all public water supply systems using surface water must disinfect the water and have a disinfectant residual remaining in the distribution system. Disinfection is usually done with chlorine. Groundwater systems are not currently required to install disinfection unless their construction, location, or monitoring results indicate it is needed.

Disinfection is needed when disease-causing organisms are likely to occur in the source water, if the water receives other treatment of any kind (such as softening or iron removal), or if problems in the distribution system indicate a chronic microbiological quality problem exists. Many Montana wells are shallow or in the alluvium of rivers or creeks, where they are more prone to microbial contamination, so they must be disinfected.

When disinfection is required, the operator/owner must ensure the treatment system is running properly and is adding enough disinfectant to kill any disease-causing organisms which may be present. This is done through daily monitoring of the amount of disinfectant added and the amount in water coming from representative taps in the distribution system. A colorimetric test kit using the DPD method is commonly used for chlorine residual determinations.

For the vast majority of systems this means daily monitoring of the ***free chlorine residual*** or ***total chlorine in chloraminated systems*** at both the ***point of application*** and in the distribution system. The monitoring sites in the distribution system are rotated to cover the entire system each week. Chlorine disinfection and other disinfectant options are discussed in Chapter 6: *Treatment of Groundwater*.

The important message here is that if disinfection is required, the operator must monitor the performance of the disinfection system and report the results to DEQ.

Chlorine residual report forms are available free of charge from DEQ. They cover a one-month period and have been designed to direct the water system operator to collect the minimum information needed. The forms make duplicate copies, so one copy is retained by the system and the original is sent to DEQ by the 10th of the next month.

### ***2.4.4 Fluoridation***

***Fluoridation*** is the term used to indicate when fluoride is added to drinking water. In Montana, fluoridation is an optional process. Several community water systems and some schools add fluoride to the drinking water to help prevent tooth decay.

A small amount of fluoride in the diet is essential to the health of teeth and bones. Fluoride levels between 0.9 and 1.5 ***parts per million (ppm)*** are considered optimal for Montana systems. Some water supplies have naturally occurring fluoride at or near optimal levels.

At levels above 2.0 ppm, fluoride is known to cause brown mottling (discoloration) of teeth. At levels above 4.0 ppm it is suspected of causing brittle bones. Fluoride is toxic and has been shown to be fatal if the concentration in drinking water is too high. These incidents of acute toxicity have been attributed to improper fluoride addition to a water system, not naturally occurring levels in water.

Systems which add fluoride must report the amount of fluoride maintained in the water after fluoridation. Fluoride monitoring must occur daily and results must be reported to DEQ each month. One sample of water must be submitted to a certified laboratory each month for fluoride analysis. These laboratory checks are helpful for identifying problems with on-site testing.

### ***2.4.5 Lead and Copper Monitoring and Corrosion Control***

Community and non-transient non-community public water supply systems must monitor water at service taps (homes, drinking fountains, etc) to determine if the water is corroding lead or copper from pipes, and to determine if lead or copper are present in source water in unacceptable amounts. Lead is a health concern because it is known to severely reduce the IQ development of children and can cause nervous system and kidney disorders. Copper is toxic at high levels and can cause gastrointestinal disorders. Small amounts of copper can be lethal to individuals with Wilson's Disease.

Across Montana, some source water has been found to be corrosive to pipes, tanks and home plumbing. Corrosion control is used to reduce the **corrosivity** of the water. Often this is accomplished by adjusting the pH and alkalinity of the water, or by adding a corrosion inhibitor to the water. In eastern Montana, high levels of natural salts may make the water corrosive. In this case, other treatment options or replacement of lead or copper pipe may be considered.

Monitoring for lead and copper is unique in that it requires collecting the 'first draw' of water that has been sitting in pipes for at least six hours. Community systems often must educate and train homeowners on proper collection procedures so they can collect the samples before any water is used in the home in the morning.

Lead and copper are regulated as "**action levels**"—levels at which the system must investigate water chemistry related to corrosivity—and determine what treatment is necessary.

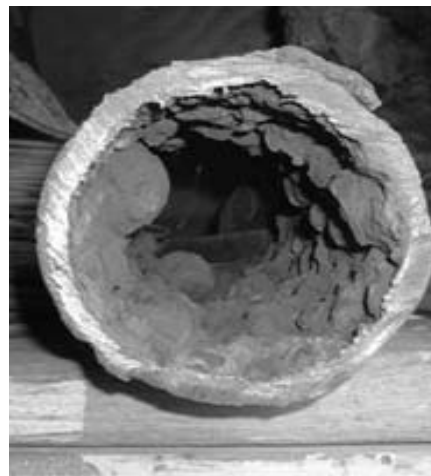

**Figure 2.4.5 Heavily corroded**

### ***2.4.6 Secondary Contaminants and Aesthetic Concerns***

Secondary contaminants have a recommended maximum contaminant level. Since the levels are guidelines, they are not enforceable health limits. Secondary limits relate to the appearance and palatability of water—things like hardness, taste, odor, color, iron and manganese levels. These contaminants are not necessarily required to be monitored, but recommended limits are established below which water would be of good taste and appearance.

Complaints about iron and manganese are common in some parts of Montana. They produce brown and black stains on fixtures, porcelain plates and laundry when in levels higher than their recommended level. They are often controllable with a **sequestering agent**. This agent binds them in a form that will not cause staining, although they are not removed from the water.

Hardness is another common complaint in some parts of Montana. Aside from consumer concerns about soap use and the way it makes skin feel, hardness also can plug distribution piping. Home water softeners help with consumer needs, but centralized treatment is necessary to protect distribution pipes.

Sulfide gas and other aesthetic concerns are also common in parts of Montana. DEQ staff is a valuable resource for owners and operators looking into options for controlling these problems.

Remember, even if the contaminant is not a regulated contaminant, all plans and specifications for the addition of treatment must be approved by DEQ prior to installation of any equipment.

### ***2.4.7 Regulations for Professional Water Haulers for Cisterns***

Water haulers who move water from a public water supply source to fill cisterns or other reservoirs used to provide water for human consumption are also regulated. This is a public water supply if the water is hauled to

## **Chapter 2: Public Water Supply System Regulations**

cisterns or other reservoirs serving a total of 15 or more service connections or 25 or more persons at least 60 days of the calendar year. Regulations for commercial water haulers govern the materials used for the hauling tank, all water contact surfaces, sanitizing the equipment and chlorination of each load of water. Haulers are not required to perform chemical contaminant monitoring of the water as long as the public water system from which they obtain the water is up-to-date on all required monitoring and reporting.

A copy of the regulations detailing the requirements for water hauled for cisterns may be obtained from DEQ.

### **2.5 Monitoring Schedules**

The monitoring requirements for public water supply systems can be very complex. DEQ has developed a report which identifies specific monitoring needs for individual systems. The report includes charts covering microbiological monitoring, nitrate, lead and copper, other chemical contaminants and radionuclide monitoring requirements.

Each public water system is strongly encouraged to contact the DEQ Public Water Supply Program to obtain the most up-to-date version of the report for their system. It will indicate the most recent monitoring results on record, and subsequent samples that must be collected.

### **2.6 Sample Collection and Analysis**

Certified laboratories must be used for all microbiological and chemical contaminant monitoring. Certified laboratories are licensed by the state and have met minimum requirements for accuracy and performance of test methods. A list of all certified laboratories is available from DEQ. Convenience, cost of analyses, and service are all valid items to consider when choosing a laboratory.

Certified operators must collect all microbiological samples for community water systems. If required for the system, they must also take all measurements for pH, temperature, turbidity, and residual disinfectant (chlorine) concentration.

As a reminder, it is up to the water system owner/operator to be sure all monitoring results are reported to DEQ. Sometimes it can be arranged with the laboratory to have results sent directly to DEQ. In other situations, the system must make copies and send the results themselves.

### **2.7 Public Notification**

The primary purpose of public notification is to inform consumers of any requirements that are not met and steps they can take to minimize the impact.

Public notification provides consumers with information that will educate them about the extent to which the water system is meeting standards. It can also encourage them to support the expenditures necessary to provide safe water.

Public notification must be provided when the system:

- 1) exceeds a maximum contaminant level;
- 2) fails to monitor for a contaminant as required; or
- 3) is operating under a special allowance, termed a *variance* or *exemption*.

The method and timing of a public notice is determined by the severity of the problem. In some cases the problem must be announced on radio and TV within 24 hours of obtaining the test result. This is necessary when the contamination presents an immediate health threat to consumers. Specific language is required to be given with the notice.

## ***Chapter 2: Public Water Supply System Regulations***

---

**Consumer Confidence Reports** (CCRs) are another means of keeping the public informed. The purpose of the Consumer Confidence Report (CCR) is to improve public health protection by providing educational material to allow consumers to make educated decisions regarding any potential health risks pertaining to their drinking water supply.

The CCR Rule requires all community water systems to prepare and distribute an annual water quality report summarizing information regarding source, any detected contaminants, compliance, and educational information. The CCR must then be distributed to customers. The CCR is a public document and anyone can request a copy from the PWS, to which a copy must be provided.

A full copy of the CCR must be provided in paper or electronic format to all customers. There is an exemption for PWS that serve fewer than 10,000 persons.

DEQ requires two documents to meet compliance: a full copy of the CCR and CCR Certification Form. The CCR Certification Form certifies that the CCR was distributed.

The CCR includes information from the previous year, for example the 2015 CCR includes data from 01/01/2015 to 12/31/2015 and is due to the consumer and DEQ by June 30, 2016. The 2015 CCR Certification Form is due to DEQ by September 30, 2016.

### **2.8 Public Water Supply System Annual Fees**

In 1991, the Montana Legislature approved a fee structure to help fund the Public Water Supply Program. All public water supply systems must pay an annual fee no later than March 1 of each year. The amount of the fee is based on whether the system is a transient or non-transient non-community water system, and on the number of service connections for a community water system. An invoice is sent to each system from DEQ every year.

Fees paid to DEQ are earmarked to help maintain the primacy program and fund technical assistance and training to public water systems. This occurs in the form of materials development, training seminars, on-site assistance and additional staff. System fees are combined with state funds to match EPA funding for the program.

### **2.9 Other State Requirements**

In addition to the previously mentioned requirements of the SDWA, there are other state regulations which pertain to public water supply systems. Some of these are covered here.

#### ***2.9.1 Cross-Connection Control***

Cross-connections are physical arrangements of piping between a public water supply and a non-potable system in such a manner that a flow of water or contamination into the public water supply system could occur. The 'other' water system could be sewage piping or a non-public water source such as a private well.

Examples of common cross-connections are animal watering hoses left submerged in stock watering tanks, and frost-free hydrants installed on the top of well casings.

Cross-connection control programs are very important for drinking water systems. They are covered in Chapter 8: *Cross-Connections and Backflow Prevention*.

## ***Chapter 2: Public Water Supply System Regulations***

---

### ***2.9.2 Uniform Plumbing Code and State Amendments***

The uniform plumbing code affects public water supply systems by specifying the limits to which a certified operator may work on residential or building plumbing.

Unless they are also a licensed plumber, a certified operator may only work on the distribution system up to 20 feet outside of a building. An exception to this restriction deals with water meters. A certified operator may work on meters and associated connections within the 20 foot limit or inside buildings or homes.

### ***2.9.3 Uniform Fire Code and State Amendments***

The Uniform Fire Code addresses sprinkler systems, secondary containment of chemicals used in water treatment, and chlorine scrubber requirements for gas chlorination installations.

Sprinkler systems may be required for fire suppression in treatment buildings, depending on the volume and type of chemical used.

Secondary containment of water treatment chemicals is required if more than 500 gallons of the chemical is to be on-site. Secondary containment would be a concrete berm around the tank or other means to minimize movement of the chemical if a spill or leak occurs.

Scrubbers are required on all new gas chlorination facilities to inactivate the gas if it is released through a leak or spill. A water system may be 'grandfathered-in' to continue to use gaseous chlorine for disinfection without a scrubber. However, any changes to the system may require scrubber installation. Because chlorine gas is so hazardous, it is a good idea to evaluate installation of a scrubber even if not mandated by the fire code.

### ***2.9.4 Excavation and Trench Safety***

For both excavations and trenching, the water system owner/operator must be concerned about several items. Traffic and pedestrian safety, worker safety down in the trench or excavation, shoring to prevent wall collapse, and emergency retrieval of workers are just a few examples.

Even if the operator will not be the individual working in the trench, they should have sufficient knowledge of the safety issues to ensure safety-conscious contractors are used.

The Occupational Safety and Health Administration (OSHA) and the Montana Department of Labor and Industry Safety Bureau provide seminars on safety for water and wastewater system operators. These agencies should be utilized as a source of valuable information which saves lives and money.

Additional excavation and trench safety items are discussed in Chapter 9 *Safety for System Operators*.

## Chapter 3: Groundwater Basics

It is important to understand basic concepts about groundwater. These concepts are important because they determine the quality and chemical characteristics of the water used, the amount of water available and how protected the water is from chemical or biological contamination. Groundwater concepts include an understanding of the *hydrologic cycle* and how it affects groundwater sources, different types of aquifers used to obtain water for public water supply systems, some characteristics of groundwater movement, and basic water chemistry.

These concepts are introduced briefly in this section. A public water supply system may choose to seek the expertise of a professional hydrogeologist to obtain more information about local groundwater conditions or to perform groundwater tests. A publication, *Montana Groundwater Atlas*, has information on groundwater resources within the state. The Montana Bureau of Mines and Geology in Butte is also an excellent resource for groundwater information throughout Montana.

### 3.1 The Hydrologic Cycle

Figure 3.1 illustrates the Hydrologic Cycle. This cycle is the overall exchange of water between the earth and the atmosphere.

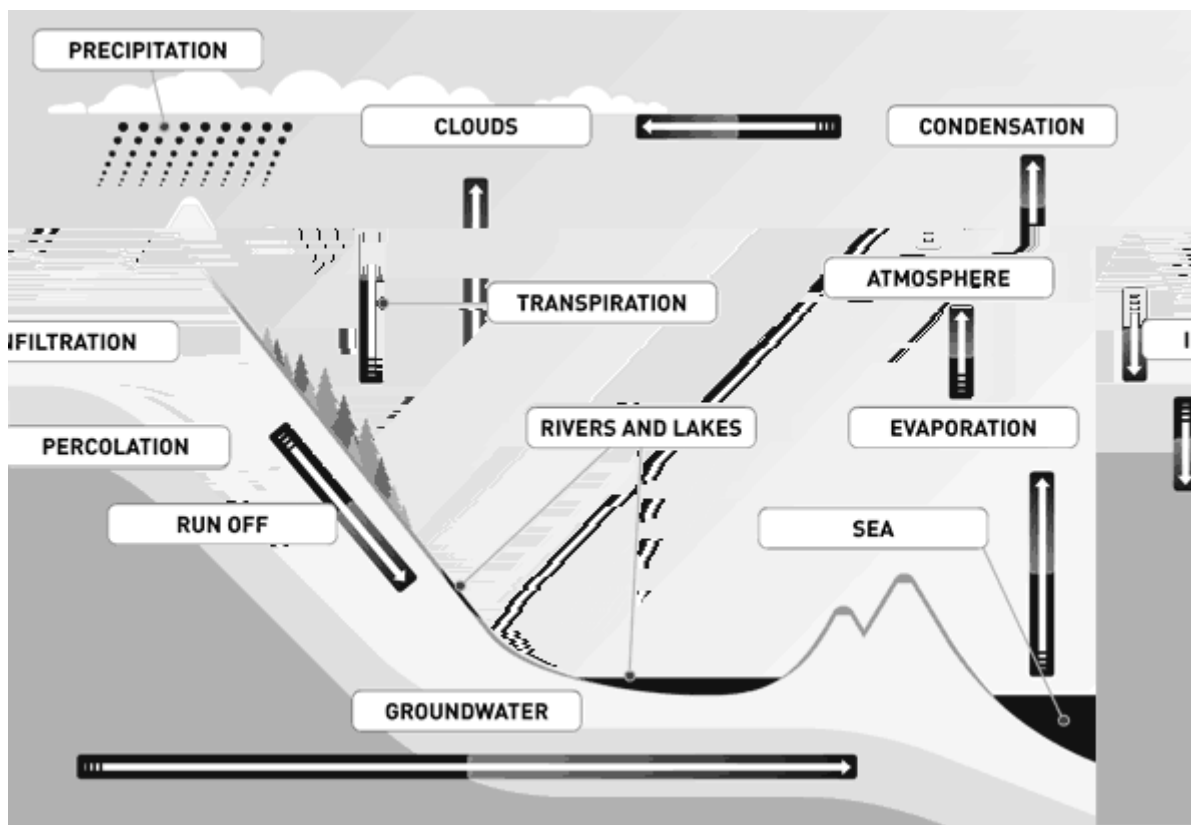

*Figure 3.1 The Hydrologic Cycle*

When rain, snow or other precipitation reaches the land’s surface some of the water renews surface waters such as rivers, lakes, streams, and oceans; some percolates into soils to be absorbed by plant roots; and some evaporates back into the atmosphere from the soil surface, from plant leaves (called evapotranspiration) and from surface water.

## Chapter 3: Groundwater Basics

Water in the atmosphere accumulates, eventually forming clouds and more precipitation. The rest of the water infiltrates the ground to become groundwater.

In Montana, most groundwater is simply water filling spaces between small grains of rock, or fractures and fissures in solid rock. It may also occur in solution channels which have been formed in limestone deposits. Underground lakes or streams only occur in areas of cavernous limestone or in tunnels from lava flows.

Most groundwater moves beneath the land surface. How fast the water moves depends on the nature of the underground rock layer the water must travel through. Most groundwater eventually discharges into springs, rivers, the sea, or other surface waters. This discharge may occur within a few days of the water entering the ground or it may take several thousands of years. The movement of groundwater is discussed further in Section 3.3.

This cycle of water through precipitation and evaporation or evapotranspiration is called the hydrologic cycle. It is an important concept because it shows how the amount of groundwater available to a well is influenced by the amount of precipitation, percolation and underground water flow which occurs in a given area.

### 3.2 Types of Aquifers

If you were able to look at a slice of the earth, from the ground surface to two miles in depth, for example, most of Montana would appear as irregular layers of different colored and textured material. The layers are a result of geologic activity which has occurred since Earth was formed.

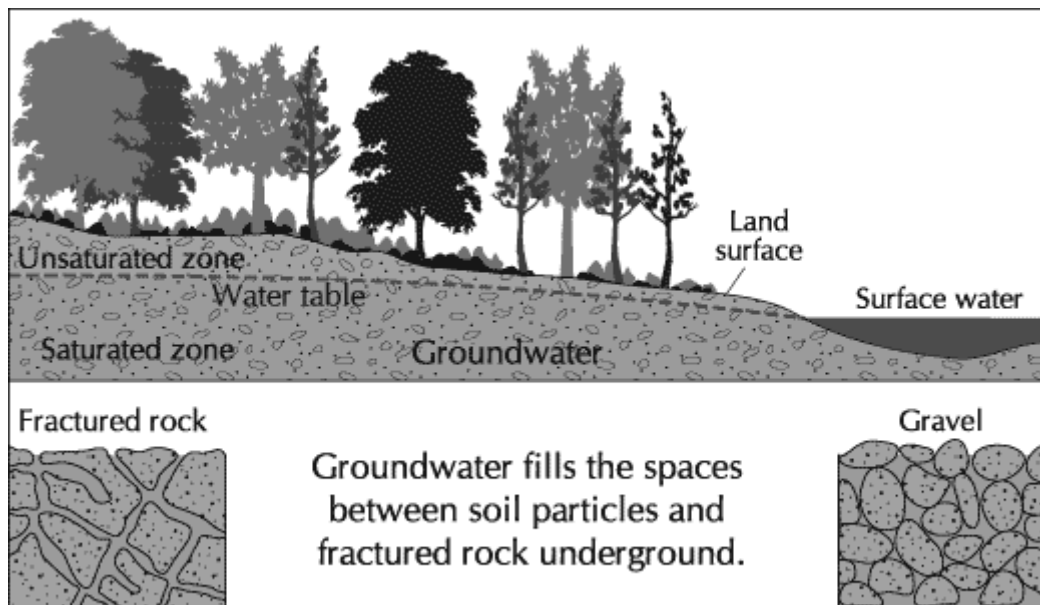

Image compliments of US Geological Survey, adapted by The Groundwater Foundation.

**Figure 3.2a Ground Water in Rocks**

Water collects in the fractures, intergranular pores, and caverns in some of the rock layers (see Figure 3.2.a). An **aquifer** is a layer that will yield groundwater in useful quantities to a well or spring. In an aquifer, all of the voids or openings between the rocks are filled with water. Water in this saturated zone (also known as the **phreatic zone**) is called groundwater. The top of the saturated zone is called the **water table**. The underground zone above the water table contains both air and water and is called the vadose or **unsaturated zone**. Aquifers are composed of either consolidated or unconsolidated materials.

## Chapter 3: Groundwater Basics

**Unconsolidated** deposits are composed of loose rock or mineral particles of varying sizes. Examples include clay, silt, sand, and gravel. Alluvial deposits such as stream beds, glacial drifts, and lake deposits are examples of unconsolidated materials.

**Consolidated** deposits are rocks formed by mineral particles combining from heat and pressure or chemical reactions. They include sedimentary (previously unconsolidated) rocks, such as limestone, dolomite, shale, and sandstone; igneous (formed from molten) rocks, such as granite and basalt; and metamorphic (highly compressed) rocks, such as quartzite and gneiss. Some limestones and sandstones may be only partially cemented and are called **semi-consolidated** deposits.

Aquifers are classified into two types—**unconfined** and **confined** aquifers. They are illustrated in Figure 3.2b.

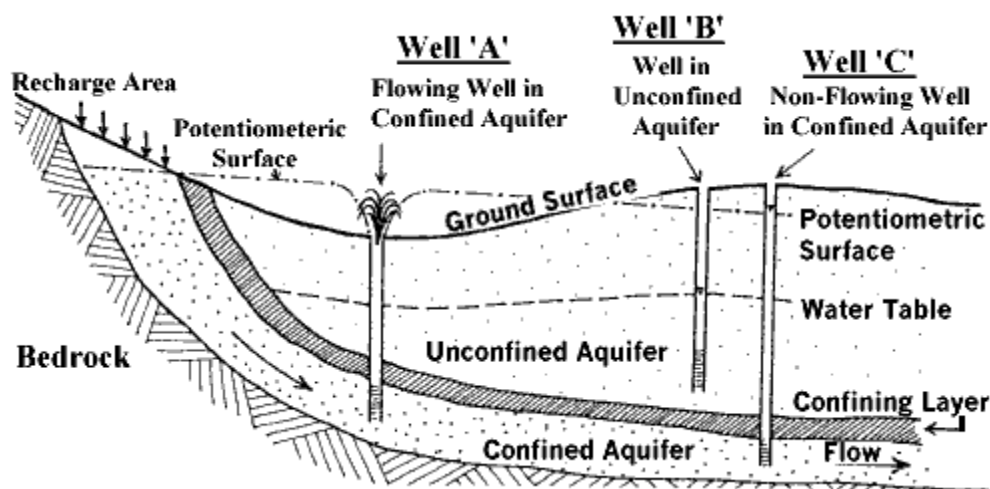

Figure 3.2b Confined and Unconfined Aquifers

Unconfined aquifers are also commonly called water table aquifers. They are not confined by an upper layer of rock or clay and are essentially at atmospheric pressure. They are also often shallow, unconsolidated materials composed of sands and gravels.

Confined aquifers are commonly called **artesian** aquifers. They are confined between impermeable layers of rock or clay. It is difficult for water or other materials to flow through this layer. Confined aquifers are under pressure greater than unconfined aquifers. If the pressure is great enough, a well drilled into the aquifer will flow, and is called a flowing artesian well.

Aquifers can range from several acres to thousands of miles wide and from a few feet to hundreds of feet thick. In some areas of Montana, the ground water table is less than 10 feet below ground surface. In other areas, systems must rely on wells drilled more than 1,000 feet deep.

In 1989, more than 67 percent of the wells serving community public water supply systems in Montana drew from aquifers less than 50 feet deep. Wells constructed in these relatively shallow alluvial aquifers have a greater potential for biological and chemical contamination than do wells constructed in deep or confined aquifers.

### 3.3 Groundwater Movement

#### 3.3.1 Effect of Aquifer Characteristics

The ability of an aquifer to receive, store, or transmit water or contaminants depends on the characteristics of the aquifer. This includes the characteristics of the confining layers of a confined aquifer or the overlying unsaturated zone of an unconfined aquifer.



Hydraulic gradient, potentiometric surface, porosity and hydraulic conductivity are important concepts which determine groundwater movement. Each of these are discussed briefly. More detail is available from references such as the *Source Water Protection Technical Guidance Manual* available from DEQ.

Groundwater generally moves quite slowly—from about several feet per day to several feet per year—although it can move much faster in very permeable soils or in certain geologic formations, such as cavernous limestone. Gravity and pressure differences are also important factors in groundwater movement. The direction and speed that groundwater and accompanying contaminants flow are to a large degree determined by the ***hydraulic gradient***.

The hydraulic gradient is the slope of a water table, or in a confined aquifer, the slope of the ***potentiometric surface*** (the surface defined by the elevation to which water rises in a well open to the atmosphere - also called the ***piezometric surface***). In many cases in unconfined aquifers, the hydraulic gradient parallels the slope of the land surface.

***Porosity*** refers to the amount of space between soil or rock particles and reflects the ability of a material to store water. Soils are said to be porous when the percentage of pore space they contain is large (such as a soil with porosity of 55 percent).

***Hydraulic conductivity*** is a term that describes the ease with which water can pass through deposits and thus transmit water to a well. Generally, the larger the pores, the more permeable the material, and the more easily water can pass through.

Coarse, sandy soils are quite porous and permeable, and thus groundwater generally moves through them rapidly. Bedrock is often not very porous, but may contain large fractures through which groundwater passes quickly. Clay soils are quite porous but not very permeable and water moves through clay very slowly.

Fractures in consolidated rock play an important role in groundwater movement. The fractures allow water to flow through them in many directions. This makes it difficult to predict and measure groundwater flow in these formations.

Aquifers composed of limestone and other water-soluble rocks often have fractures which have been widened by physical or chemical erosion to form sinkholes, caves, tunnels or solution channels. Water and any accompanying contaminants often move very rapidly in these aquifers.

#### ***3.3.2 Effect of Well Pumping***

As shown in Figure 3.3.2a, well pumping alters the natural movement of groundwater. The depth from ground level to the top of the aquifer in a well not being pumped is called the ***static water level***. When pumped, groundwater around the well is pulled down and into the well. The depth from ground surface to the water level in the well during stabilized water withdrawal is called the ***pumping water level***. The difference between the static water level and the pumping water level is called the ***drawdown***. The greater the discharge of water from a well, the greater is the drawdown experienced by the well.

The underground area affected by pumping is in the shape of an inverted cone and is called the ***cone of depression***; the same area as viewed on a map of the ground surface is known as the ***zone of influence***. The cone of depression may extend from a few feet to many miles, depending on local hydrogeological conditions. Locating additional wells within this zone of influence will cause the wells to compete with each other for water (Figure 3.3.2b).

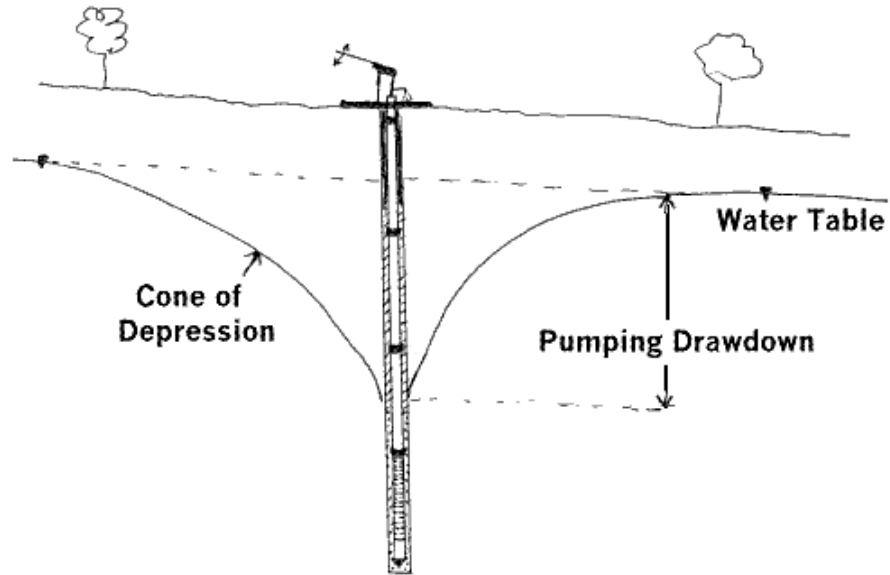

Figure 3.3.2a Effect of Well Pumping

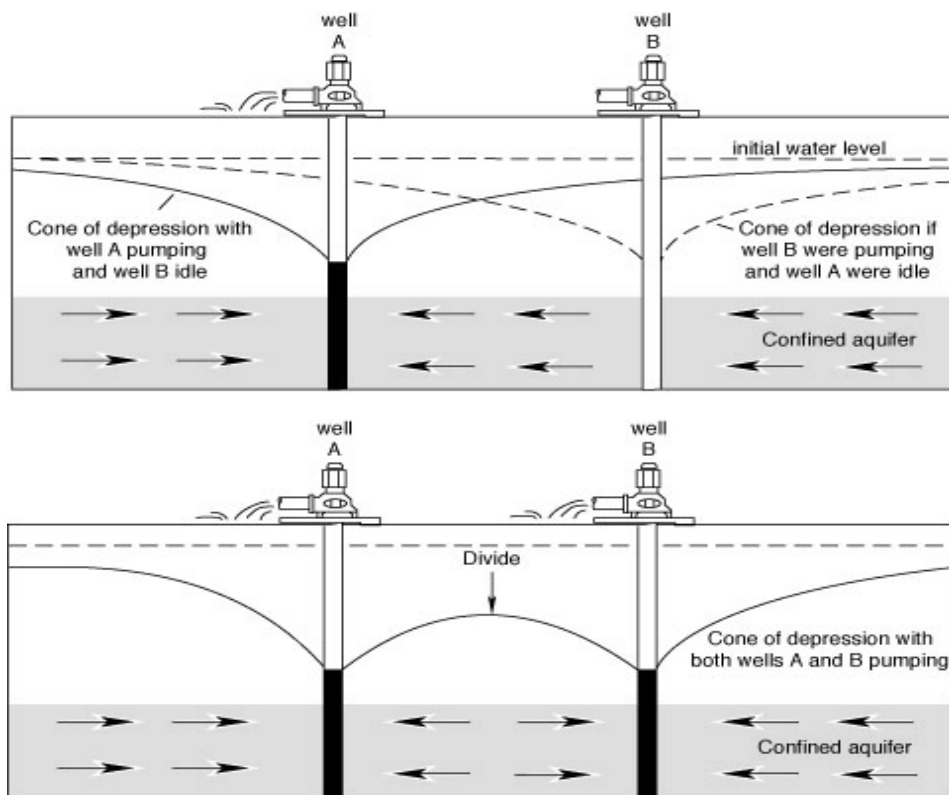

Figure 3.3.2b. Two competing wells

The *zone of contribution* is the area of the aquifer that recharges the well. The zone of contribution can also be altered by increased or decreased pumping. Any contaminants located in the zone of contribution might be drawn into the well along with the water.

### **3.3.3 Recharge of Aquifers**

The replenishment of an aquifer is known as **recharge**. Unconfined aquifers are recharged by precipitation percolating down from the land's surface. Confined aquifers are generally recharged where the aquifer materials are exposed at the land's surface—called an outcrop.

Surface waters also provide groundwater recharge under certain conditions in many areas of Montana. When a surface source water loses water to the adjacent aquifer, the stream is called a **losing stream**. When the opposite occurs and water flows from the groundwater to the stream, it is called a **gaining stream**.

Properly identifying the recharge area of an aquifer is critical because the introduction of contaminants within the recharge area can cause aquifer contamination.

Knowing if the aquifer is influenced by a gaining or losing stream helps identify periods when biological contaminants from the surface water might reach the well water. Periods of gaining and losing stream flow may change seasonally, depending on the level of the ground water table. Monitoring the surface water level or stream stage and comparing it to the static water level in the well can give an indication of the direction of water flow.

## **3.4 Brief Chemistry of Water**

Groundwater nearly always contains more minerals than nearby surface water. The main reason for the difference is the slow movement of water through soil and the unsaturated zone to underground aquifers. During this movement, groundwater becomes slightly acidic as it flows through soils. This acidic solution then dissolves some of the rock through which it travels and picks-up carbonates, iron, manganese, sulfate and other compounds. When tapped by a well, the water may no longer be acidic but may have picked-up sufficient other minerals to have changed its chemical characteristics dramatically.

The slow passage of water through soil and sediment results in some filtration of particulate matter and adsorption of some chemical compounds onto clay minerals. This may reduce the amount of chemical contaminants in groundwater and provide some degree of protection against contamination by disease-causing organisms from surface water.

There are a few significant chemical characteristics of water that are important to know. They may or may not cause problems, depending on the amount present. They include the following:

**Hardness** - Carbonates and sulfates of calcium and magnesium cause hardness, as do sulfate, chloride and nitrate. Very hard water inhibits lathering by soap and can build up as scale in hot water piping and water heaters.

**Alkalinity** - Alkalinity is a measure of water's ability to neutralize acids and is due primarily to the presence of bicarbonates.

**pH** - pH is a measure of the hydrogen ion concentration of water. It determines if water is acidic, basic or neutral. Even slightly acidic water may be corrosive to pipes, tanks, and home plumbing.

**Iron (Fe)** - A high concentration of iron causes reddish-brown stains on fixtures and laundry. It may also cause a bad taste and odor in water when associated with growth of **iron bacteria**. It may be dissolved in groundwater and not be evident until oxidized to its insoluble form by exposure to air, an oxidant, or disinfectant such as chlorine.

### ***Chapter 3: Groundwater Basics***

---

***Manganese (Mn)*** - High concentrations of manganese cause brownish to black stains. Like iron, it may not be apparent until the water has been exposed to oxygen or a disinfectant.

***Sulfide*** - Hydrogen sulfide gas has a distinctive smell of rotten eggs. Depending on the water pH, temperature and hydrogen sulfide concentration, it reacts with chlorine to form sulfuric acid and elemental sulfur - a fine white powder with a bad odor.

***Sodium*** - Sodium is a component of table salt. It may make the water taste bad and can be a health risk for people with heart problems.

***Radioactivity*** - Radioactivity in the form of radium and uranium naturally occurs in groundwater in some parts of the U.S. Radon gas is radioactive and has been found in much of Montana. Radioactivity is a concern because of its cancer-causing characteristics.

***Nitrate*** - Nitrate and nitrite occur in some groundwater and can cause a health risk for young children and pregnant mothers. These chemicals may interfere with the ability of blood to carry oxygen through the body.

Physical characteristics also affect how water will be used. Important physical characteristics include the following:

- ***Turbidity*** - Turbidity is a measurement of the light-reflecting properties of water. It is used to indicate the relative amount of suspended particles in water - those which reflect light in the turbidimeter. It is required to be monitored in all surface water systems and some groundwater systems suspected of being directly influenced by surface water (see Chapter 4: *Using Groundwater for Public Water Supply Systems*)
- ***Apparent Color*** - Apparent color is the color the water appears to be when you look at it. It is a combination of the true color and color imparted by suspended particles.
- ***True Color*** - This is the color remaining in water after it has been filtered to remove suspended particles. True color is caused by dissolved organic compounds in water, commonly called tannins or lignins.
- ***Temperature*** - Montana's groundwater sources typically have constant temperatures, although some may be warmer than others. Temperature is a useful tool for determining if groundwater is directly influenced by surface water.
- ***Taste and Odor*** - These characteristics are determined by the physical and chemical content of water. However, most contaminants do not impart either and cannot be detected by just smelling or looking at a glass of water.



## **Chapter 4: Using Groundwater for Public Water Supply Systems**

Groundwater is widely used in Montana as a source for many public water supply systems. Groundwater as a source of drinking water has a number of advantages, two of which are that it is less vulnerable to pollution compared to surface water and it may be available in areas where surface waters are not.

Most groundwater sources in Montana require minimal, if any, treatment to meet the standards that protect public health. However, groundwater is still vulnerable to contamination by chemical compounds or biological organisms. How vulnerable a particular water source is depends on the type of groundwater collector used, aquifer characteristics, and other means by which contaminants can enter the aquifer (such as through improperly constructed or abandoned wells). Vulnerability of a water source is mitigated by the successful implementation of an assortment of source water protection strategies. This chapter will provide an overview of these items and how they affect the vulnerability and treatment required of a groundwater source.

### **4.1 Types of Groundwater Sources**

#### ***4.1.1 Wells, Springs, Infiltration Galleries, Horizontal Wells***

Most water sources used by public water supply systems in Montana are drilled vertical wells. Details on well construction of vertical wells are covered in Chapter 5: *Well Construction and Well Components*.

Springs are used for a few public water supply systems in Montana. A water collection facility is typically constructed over the area where groundwater surfaces as a spring. Proper construction of the spring box or collector is critical for preventing surface runoff or other surface water from entering the device. Most of these collection facilities also have an overflow to allow the release of excess water. These collection facilities must be carefully designed to prevent contamination that would result from an assortment of vermin types that actively try to enter spring boxes or water storage and transfer facilities.

Contact DEQ to obtain a special circular on spring water collection system design.

Infiltration galleries are commonly constructed in alluvial deposits along rivers and streams. Their location is determined by the intent to either capture surface water recharging the groundwater aquifer or groundwater as it flows to the surface water body. They are relatively shallow and typically collect water through a horizontal perforated pipe or well screen. Infiltration galleries must be evaluated to determine if the source of their water makes them vulnerable to contamination by relatively large pathogenic organisms such as the parasites *Giardia lamblia* or *Cryptosporidium*. Both of these organisms are found in surface water.

Horizontal wells are constructed by installing a vertical caisson into the ground, then pushing horizontal collector laterals out from the bottom of the caisson. They can be relatively deep (100 feet deep, or more), and differ from an infiltration gallery in that the materials above the collector laterals remain undisturbed. Ranney Collectors are one type of horizontal well.

Ranney Collectors are typically shallow and located close to a surface water body with the intent of capturing water present in the alluvial aquifer. Most of these horizontal wells (if shallow) are also subject to investigation to determine if they are utilizing ***groundwater under the direct influence of surface water***—a groundwater source of drinking water that is at risk from contamination by relatively large waterborne pathogens passing into the groundwater collector from surface water.

#### ***4.1.2 Groundwater Under the Direct Influence of Surface Water (GWUDISW)***

All sources of water obtained from subsurface collectors must be evaluated to determine if they are groundwater under the direct influence of surface water. The purpose of this determination is to identify collectors drawing

## **Chapter 4: Using Groundwater for Public Water Supply Systems**

from a source of water not adequately naturally filtered by existing deposits to prevent contamination by the relatively large-diameter parasitic pathogens *Giardia lamblia* or *Cryptosporidium*.

Groundwater *not* directly influenced by surface water may still have potential for bacterial or viral contamination. However, *if* bacterial or viral contamination is present in a groundwater source, bacteria and viruses can be inactivated by proper disinfection practices. The pathogens *Giardia lamblia* and *Cryptosporidium* are more resistant to disinfection and are typically removed by filtration treatment.

DEQ has developed a procedure for evaluating groundwater sources for GWUDISW. It includes an assessment of sanitary deficiencies which might allow surface runoff or other types of surface water to enter the collector. It also looks at construction of the collector or well, location of the water intake relative to surface water bodies, and aquifer characteristics.

When more information is needed, trends in water characteristics such as pH, temperature, and turbidity are used to determine if water from the collector mimics seasonal or periodic changes in water quality experienced in the adjacent surface water body. In some cases a ***Microscopic Particulate Analysis*** is required to determine the types and amount of surface water indicator organisms that are present (such as diatoms and other kinds of algae).

If a drinking water source is determined to be GWUDISW, several options exist for how the source will be categorized by DEQ. If sanitary deficiencies are thought to be the problem they may be corrected and the source reassessed. If the source is determined to be surface water, DEQ may assess the degree of natural filtration provided by the aquifer materials and allow some amount of filtration credit for the source. The source may also be determined to be surface water without adequate natural filtration and be required to meet all of the requirements of the ***Surface Water Treatment Rule (SWTR)***, including both disinfection and filtration. A copy of the policy on GWUDISW determination is available from DEQ.

### **4.2 Groundwater Contamination**

Nearly all public water supplies in Montana provide safe drinking water. Incidents of groundwater contamination, however, have been reported in several areas of the state.

Groundwater can become contaminated from natural sources or from numerous types of human activities. Residential, municipal, commercial, industrial, and agricultural activities can all affect groundwater quality. Contaminants may reach groundwater as a result of activities on the land surface, such as:

- industrial waste storage or spills;
- sources below the land surface but above the water table, such as septic systems or leaking underground fuel storage tanks;
- structures beneath the water table, such as wells;
- contaminated recharge water.

The following are examples of how wells themselves can cause contamination of a water supply.

- *Improperly abandoned wells* act as a conduit through which contaminants can reach an aquifer. This is especially true if the well casing has been removed or if the casing has become corroded. In addition, some people use abandoned wells to dispose of wastes such as used motor oil. These wells may extend into an aquifer serving drinking water supply wells.
- *Active drinking water supply wells* or other nearby wells which are poorly constructed can allow conditions which may result in contamination inside the well or in groundwater contamination. Construction problems such as faulty casings, inadequate well caps, lack of grouting (which is actually a lack of adequate sealing around the well casings), or lack of adequate drainage away from the wellhead may allow outside water and any accompanying contaminants to flow into the well. Sources of such

contamination can be surface runoff or wastes from nearby farm animals or septic systems. Contaminated fill packed around a well can also degrade well water quality. Well construction problems are more likely to occur in wells that were in place before the establishment of well construction standards.

- *Poorly constructed irrigation wells* also can allow contaminants to enter groundwater. Pesticides and fertilizers may be inappropriately applied in the immediate vicinity of agricultural wells or public drinking water wells located on or near agricultural land. These chemicals may also be mixed in the chemical spray tank at the same time that tank is being filled. This dramatically increases the risk of overfilling the tank and spilling a large amount of liquid pesticide or fertilizer onto the ground surface in close proximity to the agricultural well.

Groundwater contamination may be biological, chemical, or radiological in nature. Generally, contamination often remains undetected until monitoring reveals the presence of the contaminant. In only a few instances was contamination in Montana public water supply systems first detected by taste or odor of the water. In these cases the amount of the chemicals present far exceeded standards established to protect public health.

If not mitigated, progressive contamination of groundwater can result in poor drinking water quality, loss of a water supply, high cleanup costs, high costs for alternative water supplies, and potential liability or health problems.

#### ***4.2.1 Biological Contaminants***

Possible biological contaminants include bacteria, viruses, and parasitic protozoans. The primary concern over biological contamination is that the organisms may be *pathogenic*, which means they are capable of causing disease. Often the waterborne diseases result in gastrointestinal illness. In some cases untreated symptoms may result in death of the infected person.

In Montana, outbreaks of typhoid fever and cholera in the early 1900's led to the first state drinking water regulations. In the late 1970's and early 1980's, outbreaks of *Giardia* in public water supply systems using surface water in Missoula, Red Lodge and White Sulfur Springs led to more stringent treatment requirements for surface water.

It is not possible to analyze water samples for every potential biological contaminant which may be present. As a result, detecting biological contamination of a public water supply system largely depends on ensuring the system is properly constructed and operated, and is monitoring the water for indicator bacteria (i.e. coliform bacteria - see Section 2.4.1) in representative water samples. Test methods for parasites *Giardia* and *Cryptosporidium* and for viruses are improving, but are not sufficiently sensitive or affordable to warrant their routine use as a monitoring tool. However, in certain circumstances monitoring for them may be required to investigate a suspect water source or biological contaminants in a public water supply system.

Bacteria are single-celled organisms occurring in the environment, on our skin, and within our bodies. Some are essential to our survival and some may make us sick. Waterborne diseases caused by bacteria include, among others, cholera, Legionnaire's Disease and gastrointestinal illness caused by a particular strain of *E. Coli*—one of the members of the fecal coliform group. Coliform bacteria in general and *E. Coli* bacteria in particular are found in the intestinal tracts of animals and these bacteria are utilized as indicators of probable fecal contamination of drinking water sources.

Viral disease agents such as the Norwalk virus and hepatitis may also be waterborne. To cause infections in humans, viruses must come from sources of pollution such as human fecal contamination or septic system effluent. Cross-connections to non-potable water sources have been tied to some viral disease outbreaks. Cross-connections are discussed further in Chapter 8: *Cross-connections and Backflow Prevention*.



Two parasitic protozoans of concern in water are *Giardia lamblia* and *Cryptosporidium parvum*. These multi-celled organisms come from the intestinal tracts of humans and a variety of animals. They are very resistant to disinfection and generally must be removed from water through filtration treatment. They can contaminate a groundwater source if:

- that source is groundwater under the direct influence of surface water,
- if septic system discharges are recharging groundwater within the zone of contribution,
- if the water collection device (well, horizontal well, surface water intake, or spring collection facility) is poorly constructed.

#### **4.2.2 Chemical Contaminants**

Potential chemical contaminants of public water supply systems include naturally occurring or human generated inorganic chemicals as well as organic compounds such as solvents and pesticides. In Montana, gasoline derivatives leaking from underground storage tanks, improper disposal of solvents used in the dry cleaning process, and weed-killers have been responsible for chemical contamination of groundwater sources.

Contaminants in drinking water may cause a variety of health effects including gastrointestinal illness, cancer risk, and possible damage to the nervous system and/or internal organs.

Monitoring for inorganic and organic chemical contaminants differs from biological contaminants in that specific chemicals can be individually identified in water samples.

Some inorganic substances found naturally in rocks or soils, such as arsenic, iron, manganese, chloride, fluoride, or sulfate become dissolved in groundwater. Naturally occurring nitrate occurs in some areas of Montana as do relatively high levels of arsenic and fluoride.

A wide variety of potential sources of chemical contamination of groundwater exist. Some septic system cleaners and additives, improper disposal of household cleaners, improper chemical storage, sloppy materials handling, and poor quality containers can be major threats to groundwater. Chemical contamination incidents in Montana have occurred through leaking underground fuel tanks, improper disposal of cleaning solvents, and inadvertent contamination of shallow aquifers by flushing solvents down floor drains connected to septic tanks or dry wells. Sewer pipes carrying wastes have also been found to sometimes leak contaminated fluids into the surrounding soil and groundwater. Long term use (or possibly overuse) of agricultural chemicals and fertilizers have also had impacts on groundwater. For example, elevated concentrations of nitrate in groundwater in many rural areas may be indicative of either agricultural land use or impacts from septic systems (dependant upon location).

#### **4.2.3 Radiological Contaminants**

Radioactivity in the form of radium, uranium, and radon gas naturally occurs in groundwater in some parts of the United States. Montana has a significant number of aquifers with radon at relatively high levels. Public water supply systems with radioactive contaminants have options for blending to achieve water below the applicable MCL, abandoning the source or applying treatment to reduce the contaminant to an acceptable level.

### **4.3 Source Water Protection**

**Source water protection** is an integral part of the multiple barrier concept for public health protection (see Section 2.2). It is a preventative effort designed to eliminate unnecessary risk of contamination to the source of water utilized by a public water supply system.

Source water protection is a community-based approach to protecting drinking water. It identifies the origins of contaminants and develops strategies to manage them at the community level through the development of a

protection planning. Source water protection can work very well with existing programs by serving as a focal point to help ensure these programs achieve the greatest benefits for the cost.

The general concepts of source water protection can be applied to public water supply systems using surface water, groundwater (also known as wellhead protection), or water from a source with significant surface water and groundwater interaction. Source water protection is an extension of the wellhead protection concept to include systems using water from any type of source.

#### ***4.3.1 Source Water Protection Planning***

Source water protection planning development is a local pollution prevention effort designed to manage a specific land area delineated according to the local hydrology (for surface water systems) or hydrogeology (for groundwater systems) to prevent groundwater or surface water contamination. Local effort and initiative are key to developing useful planning. Effective plans take into account local hydrological or hydrogeological conditions, land uses, available funding and resources, and political and economic considerations.

Developing a source water protection plan is a six-step process. The steps are:

- 1) forming a community planning team,
- 2) delineating the land to be protected,
- 3) identifying potential contaminant sources,
- 4) developing a management plan,
- 5) planning for the future through emergency plan preparation, and
- 6) state plan review and certification.

Developing and implementing a source water protection plan is voluntary in Montana. However, the benefits in the short and long run are tangible for public water supply systems, no matter their size or source of water. More information on how to set up a plan is available from the Source Water Protection Program at DEQ.

#### ***4.3.2 The Montana Source Water Assessment Program***

The 1996 Amendments to the federal Safe Drinking Water Act required primacy states (Montana is one of these) to “*carry out directly or through delegation, a source water assessment program.*” A Source Water Assessment Program will *delineate* the boundaries of an assessment area from which public water systems derive their water (surface water or groundwater) and then identify the origins of regulated contaminants to assess the susceptibility of the public water supply system to those contaminants. Susceptibility assessment is accomplished by considering Multiple Barrier Concept protection efforts (see Chapter 2, Section 2) and data from regulatory agencies to assess the significance of potentially polluting activities in delineated source water protection areas.

More information on developing a source water assessment program is available from the, *Montana Source Water Protection Manual*, DEQ Source Water Protection Program. The DEQ Source Water Protection Program has been working to develop assessments for all of the public water supply systems in the state and is near completion. Review of a water system’s source water assessment is the first step toward developing practical protection strategies and planning. The assessment should be evaluated and updated as needed before utilizing this information to begin building effective and practical source water protection planning.



## Chapter 5: Well Construction and Well Components

The quality and quantity of water obtained from a well is partially determined by the construction of the well. This chapter stresses the importance of proper well construction, discusses some of the more common construction problems that are encountered, and outlines the resources available to find information related to a specific well and/or other groundwater collector. A brief discussion of water rights is also provided to emphasize the importance of having a protected right to use the water in the well.

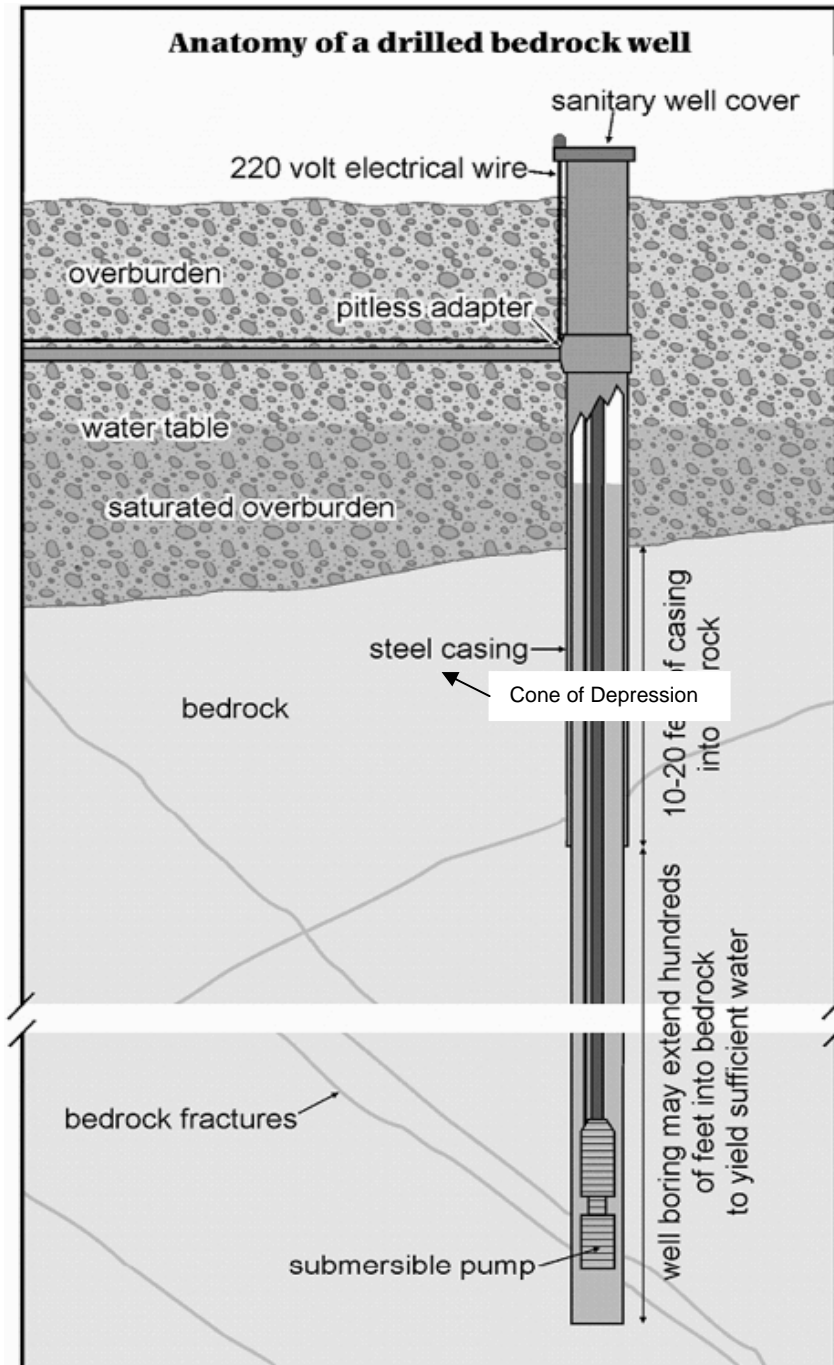

## **5.1 Information and Records**

Owners and operators new to a public water supply system may find few records of well construction, maintenance and monitoring have been retained. Information related to Water Rights and copies of the Well Log Report for each well are important documents and should be kept in permanent system files.

### ***5.1.1 Water Rights***

State law requires the owner of a well with a maximum use of 35 gallons per minute (gpm) or less, or not to exceed 10 acre-feet to file Form 602, “Notice of Completion of Groundwater Development”. This form, along with additional documentation, is to be filed by the owner within 60 days after the water has been put to use. Priority is determined by the date of filing. Filing is made through the appropriate Montana Department of Natural Resources & Conservation (DNRC) Regional Office. These Regional Offices are referred to as Montana Water Resources Regional Offices (WRRO), and can be located in your phone book under State Government - Natural Resources and Conservation - WRRO. Each WRRO has responsibility for several specified counties. Form 602 is available on the reverse side of the first copy of Form 603, “Well Log Report”, which is to be given to the well owner by the well driller when the well is drilled. It is then the responsibility of the owner to complete the form and send the entire form to the appropriate WRRO. A “Certificate of Water Right” will be issued by the WRRO. Form 602 is also available at:  
[www.dnrc.mt.gov/wrd/water\\_rts/wr\\_general\\_info/wrforms/wr\\_forms.mcp](http://www.dnrc.mt.gov/wrd/water_rts/wr_general_info/wrforms/wr_forms.mcp).

State law requires owners of wells (either a single well, or wells manifolded together) with a maximum use of *greater* than 35 gpm or 10 acre-feet to file for a permit. This differs from the notice of completion filed for small capacity wells. For wells producing greater than 35 gpm, the initial application used is Form 600, “Application for Beneficial Water Use Permit” which is to be filed *prior to water use*. The process for obtaining a permit is more complicated than for wells under 35 gpm because site-specific conditions must be considered. The local WRRO office will review other groundwater withdrawals in the area, the potential impact on other users, the need for public notice, and the need for preparation of an Environmental Impact Statement. Filing these applications does not guarantee receiving the water rights. Contact the appropriate WRRO for the county while in the design-phase of planning a new well to determine requirements for your situation and to obtain additional information.

If a water right record for an existing well is not available, or it is not known if one has been obtained, check with the appropriate WRRO for the county. They can search for an existing water right or help file for a new one.

Prior to DEQ approval, the DEQ should receive documentation that a water right application has been filed with the DNRC.

### ***5.1.2 Well Log Reports***

When a well driller drills a well, they are required to complete Form 603 - “Well Log Report”, and file a copy with the Montana Bureau of Mines and Geology (MBMG) within 60 days after completion of the well. A copy with Form 602 on the reverse side as described above is to be given to the owner for water right filing with the appropriate WRRO. If you are drilling a well, you should obtain copies of the well log report from the driller.

If no well log report is available for an existing well a copy should be acquired. Contact the well driller since they may keep a file of well log reports for all wells they have drilled. If the driller is unknown or does not have a copy try the MBMG Groundwater Information Center (GWIC) website at: <http://mbmggwic.mtech.edu>. This website has construction information on most of the wells that have been drilled in the state.

If a well log report cannot be found, have the well probed for static water level and total depth the next time the pump is replaced. Also record at what depth the pump is set and keep this information with the permanent system records.

In addition to the physical address and well location information, the well log report describes each geologic stratum encountered, the various depth(s) where water was encountered, and the overall depth of the well. It also lists construction details such as casing type and size, perforation type and depth, screens used, grout sealing methods, static water level, and test pump rates and drawdown. The well log report is also a critical document when making the “Groundwater Under the Direct Influence of Surface Water” evaluation described in Section 4.1.2. Well logs are also collected in the Groundwater Information Center (GWIC) database maintained by the MT Bureau of Mines and Geology (<http://mbmgwic.mtech.edu>).

## **5.2 Well Construction**

Well construction begins with preparation of specifications tailored to system needs, based on the geology of the area. Community public water supply systems must use a professional engineer for this step. Non-community systems can obtain a standard set of specifications from DEQ, and their personnel can provide additional specific advice. A contractor licensed by the Montana Board of Water Well Contractors must be present and in responsible charge whenever a drilling rig is in operation for a well to be used for a public water supply system.

Well construction is one of the most important aspects of system construction. Owners and operators need to have a basic understanding of well construction techniques, components, terminology and maintenance. This section provides a discussion of significant items.

Additional details on well operation, maintenance and construction are found in *Small Water System Operations and Maintenance, 4th Edition*—See bibliography.

### **5.2.1 Soil and Water Bearing Formations**

As the well is being drilled, the driller logs each change of formation and each water bearing formation. Interpretation of this data indicates where the casing will be perforated and the quantity of water that might be expected. It also shows whether there could be water movement from shallow groundwater to deeper aquifers.

### **5.2.2 Well Construction Methods**

The four most common types of wells are dug, drilled, bored and driven wells.

Hand-dug wells were once common in areas of Montana where groundwater was shallow. However, because these shallow wells are prone to contamination and lower yield during times of drought, many have been abandoned and replaced. Of those still in use, most have required disinfection as treatment to protect consumers from pathogenic organisms which may reach the shallow aquifer or contaminate the well through deficiencies in its construction.

Drilled wells are typically constructed either by rotary drilling or the cable-tool method. Rotary drilling involves the use of a rotating cutting bit on the end of a rotating drill pipe. Drilling fluid, compressed air or suction is used to carry the cuttings to the ground surface. In the cable-tool method, a heavy drill bit and stem are raised and dropped to crush pieces of the formation. A bailer is used to periodically bring a slurry of water and cuttings to the surface.

Bored wells are constructed with earth augers which look similar to an oversized drill bit. They are typically less than 100 feet deep.

## ***Chapter 5: Well Construction and Well Components***

---

Driven wells are constructed using a well-point connected to pipe sections. The well-point is driven into the formation with some sort of maul. They are common in sandy alluvial formations.

### ***5.2.3 Well Depth and Casing Depth***

A well must be at least 25 feet deep, and have unperforated casing to that depth, or it is considered to be a shallow groundwater well and continuous disinfection must be provided.

### ***5.2.4 Casing Type and Size***

Most well casing used in Montana is either steel or PVC plastic. Minimum specifications for casing diameter, wall thickness, weight, depth, and joints apply pursuant to the Montana Board of Water Well Contractors rules.

Temporary surface casing may be used in the construction of drilled wells, and is withdrawn as sealing material is placed around the permanent or production casing. The exception to this is where plastic PVC permanent casing is used, it may telescope into the surface casing that has been left in place.

On some older wells the surface casing has never been withdrawn so it is not always apparent what is the real size and type of the production casing. Temporary casing is almost always steel, and at least 2 inches larger than the production casing.

Design standards require well casings extend not less than 18 inches above the finished ground surface, 12 inches above the pump house floor, or three feet above the 100 year flood level.

Casings terminating flush with the ground, below the flood level of depressions, or below ground should be extended. This is accomplished by welding another piece of casing pipe to the existing casing.

Casings terminating almost flush with a concrete floor in a well house should also be extended. Often these casings are badly corroded so concrete chipping may be needed to get down to sound casing necessary for an adequate weld.

### ***5.2.5 Perforated Interval and Screens***

As the well is being drilled, the driller logs the depth to each water bearing formation as it is encountered. After the casing is in place, various tools can be used to perforate the casing at these intervals to allow water into the casing. Some wells are drilled into a single water bearing formation, and the casing is left open at the bottom. Screens are often installed in high production wells, and in some wells where sand or other soil conditions might be a problem.

### ***5.2.6 Grouting and Sealing***

**Grout** is a generic term used to describe the seal of the **annular space** between the outside of the bore hole and the permanent well casing. Typically some type of cement or clay grout is used. The purpose of grouting is to prevent possible downward movement of surface water or runoff along the outside of the permanent well casing, and also to prevent groundwater movement between aquifers which might impair water quality or result in cascading water. All wells must be grouted to a minimum depth of 18 feet.

When grout is applied, it should be applied with a tremie pipe and pumped into the annular space from the bottom-up to prevent bridging and voids. Grout can also be fed continuously along the outside of a well casing

## Chapter 5: Well Construction and Well Components

when the well casing is being driven at the same time the well is being drilled. Grout should also be added after excavation for installation of a pitless adapter.

### 5.2.7 Well Production Terminology

The following are important terms used to understand production obtained from a well.

- **Static Water Level:** The distance from the ground surface to the water level in the well when no pumping is occurring.
- **Pumping Water Level** (or dynamic level): The distance from the ground surface to the water level in the well when pumping.
- **Drawdown:** The difference between the static and pumping water levels. Drawdown is generally calculated based on a fixed pumping rate and a stabilized drawdown condition. The pump intake must be below this level.
- **Well Yield:** The quantity of water pumped per unit of time usually in gallons per minute (gpm).
- **Specific Capacity:** A measure of yield per foot of drawdown expressed as gpm/ft. (For example, if a pumping rate of 320 gallons per minute causes a drawdown of 16 feet, the specific capacity is 320 gpm/16 ft. = 20 gpm/ft.)

### 5.2.8 Test Pumping

Test pumping is a procedure used to determine the yield of a well by installing and operating a pump for an extended period of time.

Test pumping must occur at 1 1/2 times the required design flow rate for the system, and should reach a stabilized drawdown condition for 6 or 8 hours, depending on the design flow rate of the well. If stabilized drawdown is not reached, pumping must continue for a minimum of 24 hours.

It pays to be just a little skeptical of recorded test pump results on some well log reports. If the data is questionable for design flows, additional test pumping would be required.

### 5.2.9 Pitless Adapters, Well Caps, Well Seals, and Well Vents

A **pitless adapter** (Figure 5.2.9a) is a fitting designed to permit frost free underground discharge from a well, while still providing access to the well for installation and removal of a pump and/or appurtenances (Figure 5.2.9c). Most pitless adapters are used with submersible pumps, although units are made to accommodate suction centrifugal and jet pumps.

Submersible pumps may also be installed without using a pitless adapter by bringing the discharge pipe out through a sanitary well seal at the top of the



*Figure 5.2.9a. Pitless adapter*



*Figure 5.2.9b. Well Cap with*

casing. In this case a heated well house must be constructed over the well to prevent freezing. When metering and/or chlorination equipment is used, this construction is common.

**Well caps** (Figure 5.2.9b) are designed for outdoor use, and come in many configurations and sizes to fit most well casings. A good well cap is designed to be both watertight and insect resistant. These caps have a steel collar with a gasket that is bolted to the well casing. A second full-cover piece with gasket and built-in screened vent is then bolted to the collar. This provides easy access to the well if needed. These caps are much better than ordinary slip-on caps.



**Well seals** (Figure 5.2.9c) are designed primarily for indoor use where a well is located in a pump house away from precipitation. These seals have an expanding rubber gasket and fit inside the top of the well casing. Standard openings are provided for various pipe sizes and pump configurations. These seals are not intended for outdoor-wells since it is virtually impossible to seal them sufficiently tight to shed water. When used outdoors, they should be replaced with the gasketed caps just described. Even when used on wells inside, these seals may develop open holes where insects can enter the well and may not have a vent. These situations need to be corrected where they exist.

When a pump starts, drawdown of the well begins, and there is a need to rapidly supply air to the well to compensate for the drawdown void in the casing. Likewise, when the pump goes off and the water in the well returns to a static condition, air must be expelled. This is the purpose of the **well vent**. Venting is important so a vacuum will not develop in the well and draw contamination into the well from some unknown source or damage the well casing. A high capacity pump in a well with a significant drawdown will require more air than a low capacity pump with little or no drawdown. Use of an appropriate well cap as described above will provide the proper venting in a single unit. However, most well seals need to have a vent installed, especially if the holes in the seal are plugged to keep insects out. Small capacity wells can be fitted with an inverted vent pipe covered with 24-mesh screen. A hose clamp would hold the screen in place. Larger capacity wells and pumps may require a larger casing vent be welded into the side of the casing. All vents must face downward and be screened.



**Figure 5.2.9c. Well seals**

### **5.3 Site Considerations and Location**

Wells are very vulnerable to invasion by insects and rodents and a poorly sited or constructed well may be impacted by surface water or runoff. Following are some of the more common site and location considerations impacting public water supply systems.

#### **5.3.1 Well Location**

Rules governing licensed well drillers and DEQ design standards are specific in terms of well location. Wells should not be located within 100 feet of septic tanks, drain fields, sewer lines, and any other structures used to convey or retain industrial, storm or sanitary wastes. In addition, wells are to be located within a 100 foot radius control zone that is protected by ownership, easements, leasing, or other acceptable methods.

Even if wells meet these setback criteria, it is not positive assurance they will not be impacted by contaminated groundwater. These should be considered minimum set-back criteria. Soils, shallow groundwater conditions and the effect of pumping adjacent wells can influence the movement and transport of contaminants. Adjacent surface waters such as lakes, rivers, and streams also may impact wells as described in the groundwater under the direct influence of surface water discussion in Chapter 4.

Wells must also be protected from livestock access. Horses, cattle and other livestock should be fenced away from wellheads to prevent damage to the cap, controls, seal and drainage area. DEQ requires source water protection planning (submitting an acceptable PWS-6 report – Source Water Protection Delineation) occur before well installation takes place.

#### **5.3.2 Drainage Around the Wellhead**

Surface drainage should be directed away from the wellhead. After installation of a pitless adapter, settling almost always occurs around the well casing. If this depression is not filled and mounded around the casing, surface water can collect in the depression and eventually “pipe” down the side of the casing into the water

## ***Chapter 5: Well Construction and Well Components***

---

bearing formation. Proper well grouting and a multitude of other factors can influence this situation, but keeping drainage away from the well is an important barrier.

### ***5.3.3 Well Pits***

Well pits were commonly used in systems constructed prior to the innovation of pitless adapters. Pits were used to avoid constructing well houses and to prevent freezing.

A few of the problems associated with well pits include flooding from seasonal high groundwater and/or system leaks, poor and dangerous access for inspection and repair, and lack of maintenance and inspection due to poor access.

Existing well pits create a danger to operators and a contamination hazard to the water system. They should be eliminated by installing a pitless adapter and extending the casing above ground. Pressure tanks can often be moved to a nearby heated building.

### ***5.3.4 Well Slabs***

In general, concrete well slabs can be useful to direct water away from the well if properly constructed. “Proper construction” is the key since many slabs eventually settle and crack.

The slabs could then serve as a place for water to collect and be directed to the casing. Well slabs may also provide safe harbor for burrowing animals, so should always be built with a footing along the entire perimeter.

### ***5.3.5 Pump Power Cable Installation***

Pump power cables must be installed with appropriate cable conduit. Without sealing the conduit around the well cap, access holes are sufficiently large to permit entry of both the cable and insects. Even when conduit is used in conjunction with a good well cap on an outdoor installation, these conduits may break loose from the fitting on the well cap if the area around the casing has settled. In all cases, these need to be immediately repaired since this is a primary entry port to the well casing for insects.

### ***5.3.6 Yard Hydrants and Sample Taps***

A sample tap is required close to the well where untreated well water can be accessed. These taps are used for monitoring many chemical contaminants and to check on the quality of untreated water.

Some wells with pitless adapters have been fitted with a frost-free yard hydrant adjacent to the wellhead. Although this provides the required sample tap, the location is undesirable since those hydrants drain to a gravel bed which may serve as a conduit for contaminants to reach the well.



Current standards require yard hydrants to be located at least 20 feet away from any wellhead. For most public water supply systems, an appropriate sample tap in the pump house or first point of entry to a building is more acceptable. An appropriate sample tap is defined as a smooth nosed tap without interior or exterior threads.

Yard hydrants are also occasionally found installed directly into the well casing through a well seal. This is a direct cross connection between the well, its hose, and standing water at the end of the hose. These hydrants must be removed from the well head to prevent contamination of the well.

## **5.4 Artesian Wells**

Artesian wells have specific design and construction standards. Artesian wells are drilled into a confined aquifer where the water is under sufficient pressure to raise the level of water in the well above the point at which it was first encountered. A “flowing” artesian well is one where the pressure is great enough that the water overflows the top of the well casing.

Sealing standards for an artesian well require unperforated well casing be extended into the confining layer overlying the artesian zone. Artesian wells are grouted into the confining layer to prevent subsurface leakage from the artesian zone.

In addition, flowing artesian wells must be equipped with a control valve so that flow can be completely stopped. They must also be sealed by the well driller to completely eliminate any leakage around the casing.

## **5.5 Well Abandonment**

Wells requiring permanent abandonment include those where use has been permanently discontinued, those in such a state of repair that continued use is impractical, those allowing intermixing of water from different water bearing formations to the extent there is degradation of the water source, and those rendered unusable due to problems encountered during the drilling process.

Wells to be abandoned must be completely filled so that vertical movement of water within the well bore and the annular space surrounding the well casing is permanently restricted. This is accomplished by following the criteria for well abandonment required by the Board of Water Well Contractors’ construction standards. A copy of these standards may be obtained by contacting the Board of Water Well Contractors, Montana Department of Natural Resources and Conservation. These standards are also available on the internet at: [www.dnrc.mt.gov/wrd/water\\_op/bwwc/default.asp](http://www.dnrc.mt.gov/wrd/water_op/bwwc/default.asp).

## **5.6 Well Pumps and Other Appurtenances**

Wells not only need pumps, but also several other critical appurtenances to function properly. Appurtenances include pumps, valves, meters, and often pressure tanks, among others. This section is written to overview these critical items as they pertain to the small public water supply system.

More information on pump types, maintenance and selection is found in *Small Water System Operations and Maintenance, 4th Edition*, Chapter 3—see Bibliography.

### ***5.6.1 Pump Types***

Pumps used in public water supply systems may be categorized into two broad groups, ***positive displacement pumps*** and ***variable displacement pumps***.

Many liquid chemical feed pumps used in the water industry are positive displacement pumps. This includes rotary pumps and piston or plunger pumps. They are also referred to as constant displacement pumps. Constant displacement pumps deliver virtually the same quantity of water regardless of the ***head conditions*** (how much pressure—in feet of height—the pump must work against).

Variable displacement pumps include centrifugal pumps, jet pumps and air lift pumps. As the head increases on these pumps, the flow decreases. The type and size of pump selected for a particular situation will depend on the required capacity, location and operating conditions, and total head for the system. ***Pump curves*** are used to determine the expected performance of a pump at a given head and flow. Pumps need to be selected carefully. After the needed characteristics have been determined, the advice and expertise of a pump manufacturer’s representative or an engineer should be sought to select the proper pump.

Centrifugal pumps raise water by creating centrifugal force with a spinning wheel, referred to as the impeller, inside a tight casing. Vertical turbine pumps are a type of centrifugal pump used in many water wells. These pumps have the motor mounted at the casing top with a line shaft and column pipe which supports the pump section submersed in the well. The long pump shaft rotates inside of the pipe and drives the pump rotating impellers. A deep well turbine pump is a combination of several stages of centrifugal impellers connected in series to a common shaft. Correct alignment of the motor, shaft and the pump are important for long life and good performance. The pump column must be vertical and straight within the well casing and the motor mounting must be stable.

Lubrication of the pump is essential for continued operation. Water is discharged at the surface and a heated well house is necessary.



**Figure 5.6.1a Submersible pumps**

*Submersible pumps* (Figure 5.6.1a) are also centrifugal pumps but have their motor mounted directly below the bowl assembly which houses the pump intake and impellers. Maintenance for these pumps is minimal because there is no line shaft or oil tube requiring operator attention. They are commonly used in moderately deep to very deep wells.

*Jet pumps* use a centrifugal pump and a nozzle and venturi tube to create a partial vacuum to pump water. A portion of the water is recycled to the nozzle and this makes jet pumps inherently inefficient. They are useful in small diameter domestic wells, but are also common to some water systems where the depth to water is relatively shallow.

### **5.6.2 System Appurtenances**

A *check valve* is necessary on the discharge side of the pump. This valve acts as an automatic shutoff when the pump stops. It keeps water in the system from draining back down into the well.

A *pump control valve* eliminates pipeline surges when the pump starts or stops. It opens and closes slowly to prevent damaging surges in the water system.

A *foot valve* is often placed at the inlet to the pump suction line. It maintains the prime on the pump and prevents the reversal of water back into the well when the pump shuts off. This prevents sand from being stirred up in the bottom of the well.

*Flow meters* are essential to tracking the amount of water being delivered by the pump to the system. They are more accurate than the rated capacity of the pump. Flow meters allow monitoring the pump production in gallons per minute, total water system use (which can indicate leaks if demand suddenly increases), and can indicate changes in aquifer production or encrustation of the well screen.

*Air and vacuum valves* are also referred to as air release/vacuum breaker valves. They are used for deep well pumps to enable entry and release of air in the pump column when the pump stops and starts. This keeps air out of the water system distribution piping and prevents a vacuum from being created when the pump column drains of water.

### ***5.6.3 Plumbing a Pump Station***

Although a small water system operator may not be expected to perform detailed plumbing work, a few items regarding pump station plumbing are important.

The warm, humid and enclosed environment commonly found in pump stations and well houses may create a corrosive situation for exposed metal piping. Aside from controlling humidity in these facilities, maintaining a good coat of paint on exposed pipe surfaces will ensure greater longevity of the pipe.

Piping and fittings used should be of compatible materials. Connecting pipes of different metallic materials may result in ***galvanic corrosion*** - corrosion caused by the electrical current created when dissimilar metals are in contact with each other.

### ***5.6.4 Electrical Safety***

These safety precautions must be used when working around electrical equipment. The list is from *Small Water System Operations and Maintenance, 3<sup>rd</sup> Edition*. This reference has an additional list of troubleshooting tips for operators knowledgeable enough to work on electrical equipment.

1. Only qualified persons can work on electrical equipment,
2. Electrical installations must be maintained in a safe condition,
3. Electrical equipment and wiring must be protected from mechanical damage and environmental deterioration,
4. Covers or barriers must be installed on boxes, fittings and enclosures to prevent accidental contact with live parts,
5. An acceptable service pole must be used,
6. Equipment must be suitably grounded,
7. Provisions must be made for suitable undercurrent protection,
8. Machinery must be locked out during cleaning, servicing or adjusting,
9. Machinery must be de-energized, locked or blocked to prevent movement if exposed parts are dangerous to personnel,
10. If a switch or circuit breaker is tagged and locked out, only the person placing the tag should remove it, and
11. All outlets should have ground fault protection.

The combination of water and the electrical power needed to transport water can lead to an inherent danger of electrical shock to an unprepared water system operator. Although operators are not expected to be expert electricians, about 75 percent of pump and control problems are reported to be electrical. Since this indicates some response to an electrical problem will be faced by many operators, electrical safety for small system operators is largely an emphasis of how to recognize and avoid potentially dangerous situations.

Small water systems that do not have a knowledgeable operator or electrician on staff should arrange with a local electrical firm or pump company to perform this service. No one should attempt servicing or troubleshooting electrical components of well pump operations unless they have a good working knowledge of electrical circuits and circuit testing.

Motor starters are basically controls for starting and stopping motors. When the switch is 'on', electrical current is fed into the motor so it will run. Even if switches are in the 'off' position, electrical current is available to that switch for operations. Most wells or large pumps will be energized by 240 or 480 volts. Extremely large pumps may be energized even higher.

When any work is being done on wells or pumps, lock-out the electrical current to the equipment. This is done by opening the breakers so the electrical current is turned off. Non-conducting rubber mats should be placed on the floor in front of all power panels and motor control centers.

## **5.7 Pressure Tanks**

Pressure tanks (Figure 5.7), or *hydropneumatic pressure tanks*, can be used successfully to maintain pressure throughout small distribution systems. Tank size can range from 40-gallons to 21,000-gallons or more. The tank stores water under pressure.

In a conventional pressure tank, pressure is developed by pumping water into the tank until the air in the tank is compressed to a pre-set pressure. An air compressor is used to ensure adequate air pressure is maintained. When the pre-set pressure is obtained, the pump shuts-off and water demand in the system can draw on the stored water. When sufficient water has been withdrawn to reduce the pressure to a minimum level, the pump starts.

In larger installations, pressure tanks provide storage for the entire system. When smaller tanks are used their primary purpose is to provide only minimal storage so the pump does not activate every time water is used, allowing the well pump to cool sufficiently between starts. The DEQ recommends 6-8 pump cycles/hour with a minimum pump run time of one minute. Most water systems should have a pressure tank with a usable storage capacity of about twice the pump capacity in gallons per minute.



**Figure 5.7 Captive air tanks**

All pressure tanks should be installed with a pressure relief valve and some means to replace air in the tank. Maintenance of these tanks includes inspection of the exterior surface for signs of corrosion or other damage, checking the adequacy and operability of the air-charge system, verifying the pump cut-in and cut-out pressures are adequate to meet system needs within the safety limits of the tank, and checking the operability of the pressure gauge.

Many smaller tanks are now bladder-type tanks (sometimes called “captive air” tanks) which use a bladder to separate the air/water interface. This prevents loss of air to the water so an air compressor is not needed. More information on pressure tanks is included in Chapter 7: *Distribution Systems*.

## **5.8 Well and Pump Maintenance**

A water well consists of three main parts:

- 1) pumping equipment,
- 2) well hole, including the casing and screen, and
- 3) aquifer, especially the aquifer immediately around the well.

If any one of these parts begins to fail, the whole system suffers.

A public water supply system operator can do something about extending the useful life of a water well. Wells are expensive to drill and the cost of replacement is increasing. Therefore, it is important the old well be carefully examined to determine the reason for problems. Well problems which may affect production are typically caused by either normal wearing of pump parts or changing aquifer conditions. Keeping good records concerning pump maintenance, well yield, water quality, and other well characteristics assist in detecting problems which may affect production.

### ***5.8.1 Routine Pump Maintenance***

Because of the diversity of groundwater systems and the pumps supplying them with water, it would be impossible to describe a pump maintenance program applicable to all possibilities. In general, however, there are key components of pump maintenance programs which all systems should follow.

Generally, maintenance requirements for submersible pumps are limited to tracking production of the well and periodic inspection of the pump. Well production is indicated by:

- 1) metering production and pressure from the well, and
- 2) tracking the flow in gallons per minute pumped and total volume of water pumped on a daily or weekly basis.

Since the pump itself is not easily accessible for routine inspection, some of the items indicated below do not apply. Submersible pumps *are* prone to problems caused by sand. Increases in the amount of sand pumped may result in lost production and be indicative of well screen corrosion.

The following information was taken from Chapter 5 of California State University's *Water Distribution System Operations and Maintenance*—see *Bibliography*.

#### **Pump Inspection and Preventive Maintenance Procedures:**

- Observe and record pump pressures and flow and the pump's electricity demands.
- Check for abnormal noise or vibration from all pumps and heat or odor from non-submersible pumps.
- Provide proper lubrication of pump bearings using water or food-grade lubricants specified by the pump manufacturer. Over-greasing and under-greasing are both problematic for pump operation.
- Look for soapy or foamy appearance of the lubricant which could indicate water infiltrating the bearing shaft seals.
- Listen for any bearing noise.
- Tighten packing glands to permit only a small amount of leakage. Do not over tighten to prevent all leakage. Check the leakage rate daily.
- Inspect the pump priming system for performance and leakage.
- Check automatic pump controls and exercise standby generators each week.
- Check pump alignment on cold pumps and after they have run long enough to reach the proper operating temperature.

Routine pump maintenance would be described in the owner's manual for an individual well pump. It is important to have a copy of the manual and to review maintenance items described therein.

### ***5.8.2 Well Maintenance and Troubleshooting Declining Yield***

One problem which may occur is a steadily declining yield of water from a well. This can be caused by poor performance of the pump, by encrustation or plugging of the well screen or slots in the casing, or by conditions in the aquifer. Before any action is taken, it is important to determine what is causing the reduction in yield. If it turns out to be a declining aquifer (i.e. decrease in available water or changes in aquifer characteristics), drilling a new well in the same area may not be the answer.

The pumping equipment is the most easily controllable and correctable part of the system. Pump problems are mechanical or electrical and can be corrected by a knowledgeable operator or a good pump mechanic or electrician. Submersible pumps will tolerate little if any sand wear. For this reason submersible pumps should not be lowered too near the bottom of the well. However, proper positioning of the pump is important because submersibles can be damaged by running dry. Before assuming the pump is the cause of reduced yield, a flow

## **Chapter 5: Well Construction and Well Components**

test of the pump should be made. Static and pumping water levels in the well should be checked against records of the well's previous performance.

Just as thorough medical records are an important tool in understanding and protecting human health, thorough well records are an important tool for understanding and protecting well water supplies.

The static water level measures the level of water in the well when the well is at rest with no pumping. The pumping water level is measured when the pump has operated long enough for the water level in the well to have stabilized. The difference between the static water level and the pumping water level is termed the drawdown (see Figure 5.1). If the pumping rate in gallons per minute is divided by the drawdown in feet, the *specific capacity* of the well is calculated. This is the number of gallons of water obtained for each foot of drawdown and is a good indicator of the health of the well. To measure static and pumping water levels, the operator needs to have some means of measuring the water level and the output of the pump.

Three methods can be used to measure water well levels:

- 1) A tape measure with a plumb bob can be used on shallow wells, but becomes nearly impossible on deeper wells,
- 2) A special tape which uses an electrode to indicate the point of water contact, and
- 3) The air line method.

In the air line method, tubing of known length is installed (preferably when the well is constructed) to a depth below the pumping water level reached during full drawdown. At the wellhead, air is pumped into the tube until a small constant pressure is shown on an attached gauge. This pressure represents the head necessary to displace the water in the tube to the depth of the tube and under water. The pressure head on the gauge, if in pounds per square inch (psi), times 2.31 is equal to the distance from the well water surface to the end of the tube. Subtract this distance from the total tube length and the distance from the top of the well to the water surface is known.

The air-line method is not quite as accurate as the electrode taping method, but has the advantage that the well head need not be opened to make measurements and is not affected by dripping water or by interference from a submersible pump.

Records of static level and pumping level taken seasonally over a period of years can give a good indication of potential problems and their source. If the static level is receding over time, then the water table may be dropping due to drought or over-pumping. If the static level remains about the same but the pumping level is decreasing over time, then there could be problems developing around the screen such as sand plugging, incrustation, pump wear, or

some loss of permeability in the aquifer around the well.

Occasionally a well casing may collapse, leading to total failure of the well. This is usually caused by corrosion of the metal well casing causing structural weakness. Corrosion can also cause the screen openings to enlarge, and incrustation to form. Corrosion can be caused by the chemical makeup of water or bacterial growth on the screen or casing. Corrosive water may require the installation of corrosion resistant screen and/or plastic casing.

Wells are expensive and should have a carefully planned, systematic program of preventive maintenance to ensure they are kept in good health. A systematic program of preventive maintenance consists of:

1. *Records:* A complete record should be maintained during the construction of the well, including the test drilling and test pumping data that preceded selection of pumps for the well. The pump equipment and well house specifications, amount of water pumped, power usage, and the maintenance costs should be kept on file.



## ***Chapter 5: Well Construction and Well Components***

---

Other characteristics, including the static water level, pumping water level and the total water pumped should be recorded weekly.

2. *Sanitation:* A well should be examined to ensure the top of the well is properly sealed and sources of contamination are prevented from entering the well. The well water should be tested, for coliform bacteria and other contaminants as required by Montana's public water supply system regulations. The pump house should be kept clean, dry, and in order. The well house should not be a storage place for miscellaneous supplies, equipment or chemicals not part of the drinking water treatment process.
3. *Inspection:* A periodic program is needed to check the pump, the drop pipe, and the motor. Typically, pumping machinery is pulled from the well at intervals of three to six years and must always be disinfected before replacement.
4. *Efficiency:* A periodic check of the pump efficiency and well efficiency should be scheduled to check the well condition and to determine pumping costs.

## **Chapter 6: Treatment of Groundwater**

Although some water is acceptable for consumption when it comes out of the ground, other water may need treatment to be safe or palatable. The water may contain harmful organisms or harmful chemicals, it may have excessive hardness, or it may have a bad taste or odor. Most taste, odor or contamination problems can be addressed through installation and operation of appropriate treatment. The decision whether to treat the water will be based on the public health impact of contaminants present and on the amount of money customers are willing to spend to reduce undesirable aesthetic characteristics.

As an alternative to treatment, in some cases it may be more economical to drill another well in a different location or aquifer. Connecting to another public water system may also be a viable option. All options should be evaluated. This chapter presents an overview of some of the options available for treatment of drinking water.

### **6.1 Overview of Disinfection**

Some groundwater sources may have bacterial or viral contamination and would not be safe for consumption without treatment. This would be evident by positive coliform and/or *E. coli* tests which indicate the water system is periodically or continuously contaminated. If a well is drawing water from a shallow aquifer or if it is a well that was not properly constructed it may require continuous disinfection.

Even if a source of groundwater is not contaminated, water in the distribution system may be exposed to pathogenic organisms. Organisms which cause disease are referred to as *pathogenic* organisms. This can occur through a break in a water line, a cross-connection, a flood or other disaster, or growth of organisms in a dead-end line. Situations like this call for periodic or emergency disinfection.

**Disinfection** is a process which kills bacteria and viruses which are harmful to people's health. Another related term is **sterilization**. This is a process to kill *all* organisms. In water treatment, it is not necessary to kill all the organisms, just the ones that can affect health. Attempting to kill all organisms would generally be too costly and is not necessary to protect public health.

Public water supply systems are vulnerable to a variety of organisms which can cause diseases such as amoebic dysentery, typhoid fever, cholera, giardiasis, and cryptosporidiosis. Most of these organisms are sensitive to disinfection, so disinfection is considered the single most important treatment step in the production of safe, potable water.

For most disinfectants, such as chlorine, the effectiveness of the disinfectant is increased with increasing water temperature. The temperature of water affects the rate of the chemical reaction. Reactions occur slowly in cold water. Also, most disinfectants are affected by pH. Water with a pH above 8 reacts with chlorine to form a less effective disinfectant. Exceptions to these general rules are disinfection by ultraviolet light which is not affected by temperature or pH, and ozone which is not affected by pH.

The effectiveness of all disinfectants is decreased by the presence of turbidity, some organic and inorganic chemicals and reducing agents such as hydrogen sulfide or certain forms of iron and manganese. If these materials are in the water, an additional disinfectant or a longer contact time may be necessary to kill or inactivate pathogenic organisms.

Although disinfectants, especially chlorine, have saved thousands of lives by providing safe water, there are some concerns about by-products formed when disinfectants combine with other chemicals in water. Disinfectants also have an upper limit of concentration which restricts the amount allowed in water routinely served to consumers. Refer to the regulations (*Drinking Water Regulations Summary – Community and Non-Transient Non-Community Water Systems* available from DEQ) for public water supply systems for details on by-product control and maximum allowable disinfectant concentrations.

Disinfecting agents other than chlorine are available and each has advantages and disadvantages to their use. Proposals for use of any disinfecting agent must be approved by DEQ prior to preparation of final plans and specifications or treatment system installation.

### 6.2 Chlorination

The most common chemical used in the disinfection process is chlorine. Chlorine is usually preferred over other disinfectants because of cost, availability and effectiveness.

The amount of chlorine which must be applied is dependent on how much it takes to obtain a **free available chlorine residual**. Chlorine in this form has the highest disinfection ability. To obtain a free chlorine residual enough chlorine must be added to satisfy the **chlorine demand** of the water. Chlorine demand may be caused by nitrogen, iron, manganese, hydrogen sulfide, or other inorganic or organic materials in the water.

The process of adding small amounts of chlorine to the water until the demand is satisfied and a free residual is obtained is called **breakpoint chlorination**. The breakpoint chlorination curve is included in Figure 6.2. As shown on the diagram, when chlorine is first added to water, it may not register a residual. The chlorine is used up by reacting with some materials such as iron, manganese or nitrite in the water. This is referred to as the chlorine demand.

Once the demand has been satisfied, as more chlorine is added a chlorine residual will be able to be detected in the water. This chlorine residual is referred to as “combined” residual because it has combined with some of the organic compounds or ammonia in the water to form chlororganics and chloramines. Combined chlorine is not a strong disinfectant and **cannot** be used for virus inactivation. As more chlorine is added, the chlororganics and chloramines are destroyed and the chlorine residual readings may actually drop.

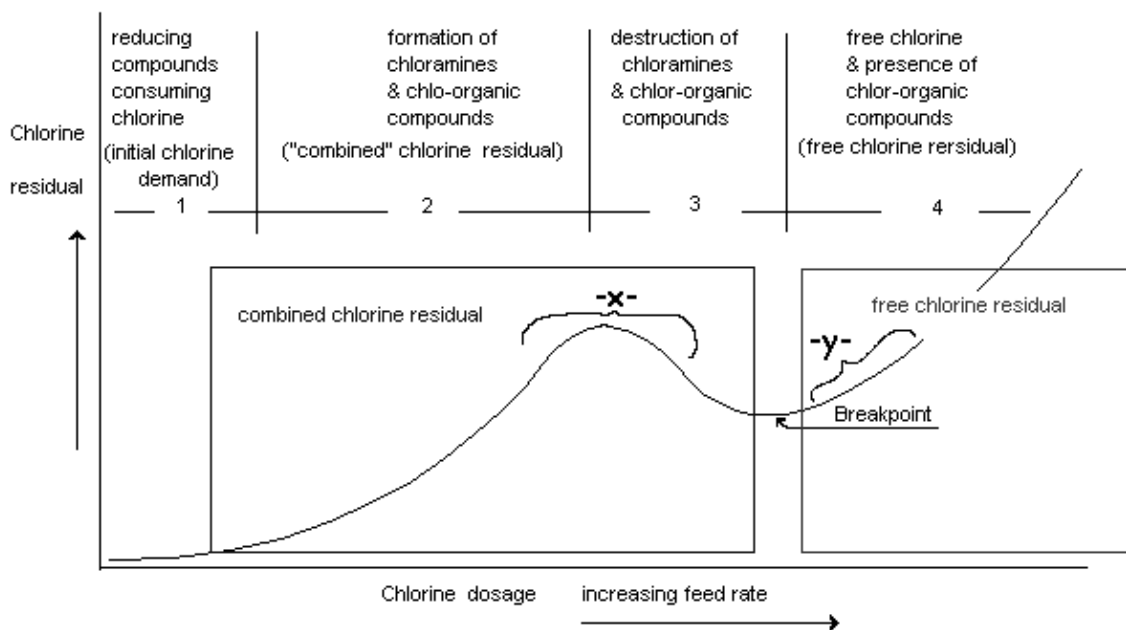

**Figure 6.2. Breakpoint Chlorination Curve**

Finally, a point is reached where adding a certain amount of chlorine to the water results in a corresponding increase in the chlorine residual. This is called the breakpoint. This residual is “free available” chlorine which is ready to react with and destroy contaminants. Free residual chlorine is the most effective disinfectant.

Public water supplies should practice “breakpoint” chlorination which means they are providing a free chlorine residual in their system.

Chlorine residual determinations and reporting are an important responsibility of the operator. Chlorine residual is most commonly measured using a DPD colorimeter test kit. This kit indicates the chlorine residual level by comparing the color produced with the DPD chemical addition to the water with a standardized color residual indicator. DPD test kits use two types of reagents to measure **Total** and **Free** Residuals. Total chlorine is the sum of the combined residual and free residual. If breakpoint chlorination is achieved the total residual should be equal to the free residual indicating the absence of combined chlorine residual. Thus, if the total residual is greater than the free residual combined chlorine exists and the system has not met breakpoint chlorination.

The amount of chlorine to be added and the contact time that chlorine has with the water prior to reaching the first consumer will vary with the objectives of the disinfection procedure. For bacterial and virus disinfection of well waters, a chlorine residual in the distribution system of about 0.2 to 0.5 mg/L after a contact time of 30 minutes is satisfactory. However, to achieve 4-log virus inactivation, the CT value will vary per system. C is the chlorine residual concentration and T is the contact time from point of application to the first user. Refer to Chapter 2 for more information on monitoring and reporting chlorine residuals in public water supply systems.

### ***6.2.1. Forms of Chlorine***

**Chlorine gas** is a greenish-yellow material with a penetrating and distinctive odor. It is more than twice as heavy as air and will settle in low areas if it is released into the atmosphere. It can be purchased as a liquified gas in 150 pound steel cylinders for use by small systems. It is a poisonous gas and must be handled with care. Chlorine gas is not corrosive unless it is in a moist atmosphere or in contact with any moisture. It then becomes highly corrosive and is especially destructive to electrical equipment. Liquified gas chlorine is the least expensive form of chlorine, but for safety and maintenance reasons it may also be the least desirable for small public water supply systems.

**Sodium hypochlorite**, NaOCl, is a liquid containing 5 percent to 15 percent available chlorine. The 5.25 percent solution is sold in grocery stores under trade names such as Clorox, Purex, etc. This form can be used for emergency disinfection and then flushed away, but should not be used for continuous chlorination. Only products which meet National Sanitation Foundation (NSF) Standard 60 for drinking water additives may be used for continuous disinfection of public water supply systems. Products meeting this standard have been tested to prove they do not contain harmful contaminants. As an example, some swimming pool chlorination products contain cyanide and must not be used for continuous disinfection of drinking water.

Sodium hypochlorite can be conveniently added to water using a small solution feed pump. Sodium hypochlorite can lose from two to four percent of its available chlorine content per month at room temperature; therefore, manufacturers recommend a maximum shelf life of 60 to 90 days.

**Calcium hypochlorite**, Ca (OCl)<sub>2</sub>, is a white solid which is available in powder, granular or tablet form at approximately 65 percent available chlorine. It may be sold under names such as HTH, Perchloron or Pitclor. It is normally dissolved in water and then injected into the drinking water using a solution feeder.

Calcium hypochlorite is a powerful oxidizing agent and must be handled with care, kept dry and away from combustible materials. It may start a fire if the white solid material comes into contact with organic materials, such as an oily rag. It has a shelf life of about 6 months after the container has been opened. Calcium hypochlorite used for public water supply systems must also meet NSF Standard 60.

**6.2.2 Full-time Chlorination**

Public water supply systems with a history of unsatisfactory bacteriological monitoring results indicating contamination of the water, with sources of water that have sanitary deficiencies, or which apply specific types treatment must employ full-time disinfection. Most systems use chlorination for the full-time, continuous treatment, although some very small systems such as restaurants have been approved for use of ultraviolet light. But for UV alone to be totally effective, it needs great amounts of energy or to be followed by another form of disinfection such as chlorination. Since chlorine does not inactivate cryptosporidium, a combination of chlorination and UV is more effective and efficient.

To demonstrate that continuous disinfection is being practiced, the public water supply system operator must monitor daily the amount of chlorine being added and the chlorine residual measured in the distribution system. Refer to Chapter 2 and the public water supply system regulations for details on this monitoring and reporting requirement.

When gas chlorine is used for continuous disinfection it is typically fed by use of a vacuum operated, solution feed chlorinator (Figure 6.2.2a). For safety reasons, the chlorine is handled under vacuum so any leaks will leak air into the chlorinator instead of allowing chlorine to leak into the air. The vacuum is produced in an ejector in which a small stream of water is pressured through a nozzle orifice. The vacuum produced opens a check valve and an internal valve in the chlorinator allowing chlorine to feed from the tank into the ejector where it is mixed with the water stream from the nozzle. The resulting chlorine solution is mixed with the main stream of water to be disinfected. A variable orifice flowmeter (rotameter) mounted on the chlorine gas cylinder indicates the chlorine flow rate with a small black ball suspended in a glass tube. When using a gas chlorinator, the ejector water is usually controlled either by a solenoid valve or by starting and stopping a booster pump so the chlorination system operates while the well pump is pumping and shuts down when the well pump is off.

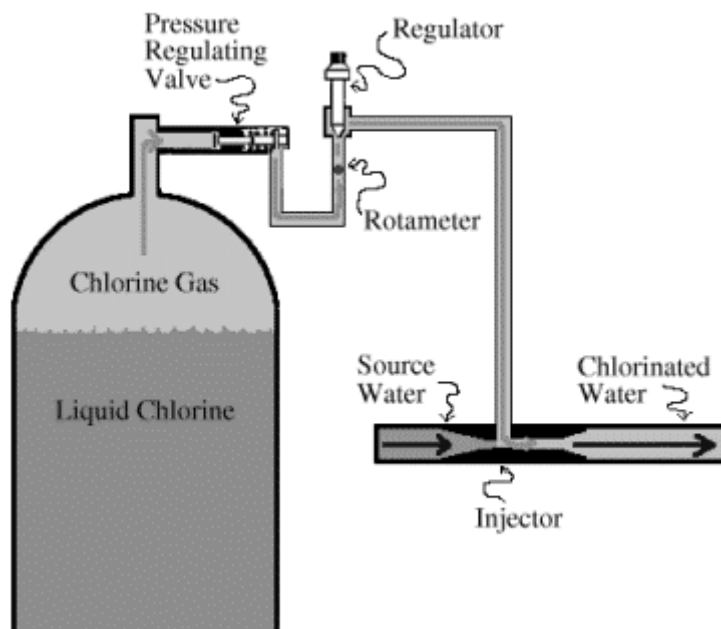

**Figure 6.2.2. Gas Chlorinator**

Liquefied gas chlorine is the least expensive form of chlorine, but is difficult to handle and therefore may not be applicable for some small systems. An overview of chlorine gas safety and leak detection is discussed later in this chapter.

Systems that use gas chlorination should refer to *Water Distribution System Operation and Maintenance* for more information.

Hypochlorination, using either calcium hypochlorite or sodium

## ***Chapter 6: Treatment of Groundwater***

hypochlorite, is often the most practical method of disinfection for small water systems. Calcium hypochlorite is usually the less expensive of the two and is often selected for that reason.

Typically, the hypochlorite is dissolved into a water solution and metered into the flowing water stream using a small diaphragm or plunger-type pump (Figure 6.2.2b).

Calcium hypochlorite tablets will not dissolve readily in water colder than 41<sup>0</sup>F, so the availability and temperature of the mixing water must be considered. In hard water, calcium hypochlorite may form a calcium carbonate precipitate which will interfere with the solution feed pump unless the chlorine solution is prepared in a separate tank and allowed to settle. The clear liquid is then siphoned to a storage tank for use.



**Figure 6.2.2b. Hypochlorinator**

Sodium hypochlorite may also form some precipitate but may not need to be settled and siphoned. Sodium hypochlorite is often fed at full strength from the container, allowing for fewer problems in handling.

Hypochlorination requires close attention by the operator as the pump and injection point often build scale. The scale will prevent the pump poppet valves from sealing and the pump will not move the solution into the water to be disinfected. Maintenance of the pump, and especially cleaning the pump valves, should be on a regular weekly schedule, or as often as experience indicates.

A hypochlorinator pump should also be wired so it starts and stops in unison with the well pump. This way, chlorine is only being added when the water is flowing from the well.

### ***6.2.3 Periodic or Emergency Chlorination***

Disease-causing organisms can enter wells, tanks and distribution mains during the construction process or during maintenance which requires exposing the pump or interior of the tank or pipes to the environment. Great care must be taken during these efforts to prevent entry of soils or water which might be contaminated.

State regulations require each of these components of public water supply systems be disinfected, flushed, and then sampled for coliform bacteria after their initial construction, repairs or maintenance. This prevents contamination of the water system and verifies the water is safe to drink before the component is placed in service.

Whenever periodic or emergency disinfection is performed, highly chlorinated water is produced and must be disposed of properly. Water with a chlorine residual above 1.0 mg/L should not be discharged to any lake, stream or other surface water body because chlorine is extremely toxic to fish and other aquatic life. Also, chlorinated water should not be discharged to a sewer if there is any possibility of a chlorine residual remaining in the wastewater when it reaches a treatment plant. Land disposal may be acceptable under special circumstances.

Before discharging highly chlorinated water, ***dechlorination*** or a discharge permit may be required from DEQ. Check with DEQ prior to discharging chlorinated water to determine if a permit or special handling of the water is necessary. Sodium thiosulfate is one chemical often used for dechlorination.

#### ***Emergency Chlorination of a Water Well***

Wells should be chlorinated according to the American Water Works Association (AWWA) Standard C654-87. This AWWA Standard contains specific, step-by-step instructions for disinfection. A copy of the standard is available from DEQ or from AWWA.

Quantities* of calcium hypochlorite, 65% (rows A) & liquid sodium hypochlorite, 5.25% (rows B) required for water well disinfection										
Depth of water in well (ft)		Well Diameter (inches)								
		2	3	4	5	6	8	10	12	16
5	A	1T	1T	1T	1T	1T	1T	2T	3T	5T
	B	1C	1C	1C	1C	1C	1C	1C	1C	1C
10	A	1T	1T	1T	1T	1T	2T	3T	5T	8T
	B	1C	1C	1C	1C	1C	1C	2C	2C	1Q
15	A	1T	1T	1T	1T	2T	3T	5T	8T	4 oz
	B	1C	1C	1C	1C	1C	2C	3C	4C	2 Q
20	A	1T	1T	1T	2T	3T	4T	6T	3 oz	5 oz
	B	1C	1C	1C	1C	1C	2C	4C	1 Q	2.5 Q
30	A	1T	2T	2T	3T	4T	6T	3 oz	4 oz	8 oz
	B	1C	1C	1C	1C	2C	4C	1.5 Q	2Q	4 Q
40	A	1T	1T	2T	4T	6T	8T	4 oz	6 oz	10 oz
	B	1C	1C	1C	2C	2C	1Q	2Q	2.5 Q	4.5 Q
60	A	1T	2T	3T	5T	8T	4 oz	6 oz	9 oz	
	B	1C	1C	2C	3C	4C	2Q	3Q	4 Q	
80	A	1T	3T	4T	7T	9T	5 oz	8 oz	12 oz	
	B	1C	1C	2C	4C	1Q	2Q	3.5 Q	5 Q	
100	A	2T	3T	5T	8T	4 oz	7 oz	10 oz	1 lb	
	B	1C	2C	3C	1Q	1.5 Q	2.5 Q	4 Q	6Q	

Quantities are indicated as: T = tablespoon; oz = ounces; C = cups; lb = pounds; Q = quarts  
 For shock chlorination of iron bacteria, the amounts of either compound should be multiplied by 10 to obtain the necessary chlorine concentration.  
 Note: For cases lying to the left of the bold line, add 5 gallons of water to the chlorine before pouring it into the well. For those cases to the right of the bold line, add 10 gallons of water.

**Figure 6.2.3. Water Well Disinfection Dosage Chart**

The disinfection procedure involves calculating the volume of water standing in the well and then applying enough chlorine powder, tablets or liquid to achieve a 100 *milligrams per liter* (mg/L) chlorine concentration (50 mg/L for new wells). The chlorine is mixed with 5 to 10 gallons of water before being carefully poured into the well. A hose is then connected to the discharge side of the pump with the outlet of the hose pointed back down into the well casing or access pipe. The pump is then activated so that water from the well is circulated back down into the casing. Circulation should continue until a strong chlorine odor is detected coming from the hose. As a rule of thumb, wells of six inches in diameter require 0.5 ounces of sodium hypochlorite (household bleach) or 0.033 ounces of calcium hypochlorite (HTH) per foot of water depth for proper disinfection. A chart of the amount of chlorine to add to a particular size and depth of well is included in Figure 6.2.3.

Draw water from the nearest tap (or the farthest one on the system if the entire system is being disinfected) until the odor of chlorine is noticeable. This allows the disinfectant to reach all necessary areas of the water system. Leave the chlorine in the system at least 12 to 24 hours to allow sufficient contact time for disinfection to occur.

Do not use water from the system during this time. The heavily chlorinated water should not be consumed. Affected consumers should receive advance notice of when the emergency chlorination process will occur and when to expect potable water to be returned to the system. Consumers will need to wait until bacteriological testing shows the water is safe before using the water for consumption, showering or bathing.

## ***Chapter 6: Treatment of Groundwater***

---

After 12 to 24 hours, discharge the chlorinated water out of the system (**caution:** follow requirements for proper disposal—do not discharge to a lake or stream) until the chlorine odor is no longer detected. Flush all other taps that contained the highly chlorinated water until the odor has dissipated.

After the well has been disinfected and flushed, wait 72 hours and collect a coliform sample to determine if the disinfection procedure was successful.

There may be times when a well has been contaminated by *iron bacteria*. These bacteria occur naturally in soil, shallow aquifers, and streams. They can flourish in wells where there is sufficient iron and/or manganese, along with either organic material or bicarbonate/carbon dioxide dissolved in the water. Although they do not cause illness, iron bacteria create white or reddish-brown gelatinous slimes on pumps, well casings, and household fixtures. They may also cause sudden yellow staining, reduced well yield, and often produce an unpleasant taste and odor in water systems.

If the well is severely plugged by iron bacteria, emergency chlorination procedures described previously may not eliminate the problem. In this case, the assistance of a professional water well contractor with experience in well rehabilitation may be needed.

### ***Emergency Chlorination of Distribution Lines***

Preventing contamination of distribution lines starts with good construction and repair practices. Pipes should be inspected while being installed to be sure no rags, bird nests, rodents, soil, rocks, weeds or other trash are present. Sanitary conditions should be maintained at all times. Open ends of pipe should be closed off at the end of each day's work and trenches should be dewatered to prevent entry of contaminated mud or slurries.

When the construction or repair work is finished, the section of pipe or other repair should be thoroughly flushed and then chlorinated according to the American Water Works Association Standard C651-92. These AWWA Standards contain specific, step-by-step instructions for disinfection of pipes. These guidelines are also available from DEQ or from AWWA. More information on tank disinfection is provided in the next section.

A portion of the AWWA Standard C651-92 reads:

*“As a general rule, sufficient chlorine concentration to provide a minimum of 50 mg/L chlorine should be added to the mains. Valves shall be manipulated to prevent the treatment dosage from flowing back into the line supplying the system. Chlorine application shall continue until the entire main is filled with the chlorine solution (it is important that a sufficiently high dose of chlorine provide a uniform disinfection throughout the length of the pipe.)”*

*“The chlorinated water shall be retained in the main for at least 24 hours, during which time all valves and hydrants in the section being treated shall be operated in order to disinfect the appurtenances. At the end of the 24 hour period, the treated water shall contain no less than 25 mg/L chlorine throughout the length of the main.”*

Under some conditions it may be necessary to reduce the contact time to less than 24 hours. In this case a stronger initial dose of chlorine should be used. A 100 mg/L dose with an eight hour detention time may be acceptable if the residual chlorine concentration is no less than 25 mg/L at the end of the eight hour period. In the case of emergency repairs when the line may only be out of service for a short time, a slug of chlorine at 500 mg/L could be slowly moved through the pipe. The operator must be very careful to ensure this highly chlorinated water is not served to customers and is properly disposed of.



In the construction of new mains the chlorine may be applied to the pipe in the form of HTH tablets as the pipe is laid into the trench. Calculations on the number of tablets to be needed in each pipe must be made prior to installation (refer to the table on page 6-8). The tablets are stuck to the top of the pipe so they will not be washed to one end of the pipe. Using this method, the tablets will not dissolve until the pipe has been completely filled with water during the disinfection phase.

Disinfection by chlorination must be followed by thorough flushing until the water shows the same chlorine residual at the outlet as the inlet. Samples of the water from the pipe or tank should then be taken for coliform testing. Satisfactory samples must be obtained before returning the repaired section to service.

Special precautions must be taken when making repairs to existing piping. The broken section of pipe must be isolated by closing valves at each end of the pipe being repaired. Often, a small flow of water is allowed to run so the leak can be located. This procedure also maintains a positive pressure on the line so that contaminated water will not enter the broken pipe. A sump (trash) pump will be necessary to keep water out of the trench. It is important to dig down sufficiently under the broken pipe so it can be thoroughly cleaned. Parts used in the repair process (clamps, fittings, etc) and the pipe should be sprayed with a high concentration chlorine solution. If there is water in the trench, chlorine may also be added for disinfection.

Additional details on main repair and replacement is found in *Water Distribution System Operation and Maintenance*.

### ***Emergency Chlorination of Storage Tanks***

Hydropneumatic tanks can usually be disinfected at the same time the operator is disinfecting the well by simply running a tap until chlorine can be smelt. This will force chlorinated water through the pressure tank. However, high concentrations of chlorine may cause some deterioration of the bladder in captive air tanks. Check with the tank supplier for any precautionary measures to be taken.

Procedures for disinfecting storage tanks are similar to those used for distribution mains. The procedures are specified in AWWA Standard C652-92. The procedure involves removing all scaffolding, planks, tools and other materials which are not part of the structure and thoroughly cleaning the tank with a high pressure hose or brush.

The AWWA standard offers three methods of disinfection, but only two are recommended by DEQ. The standard details the methods of adding the chlorine and the specific holding times, but briefly, they are as follows:

- Fill the storage tank to the overflow with potable water to which enough chlorine has been added to provide a free chlorine residual in the full facility of not less than 10 mg/L at the end of the appropriate holding time. The holding time will vary from 6 to 24 hours based on the way the chlorine is added and what chlorine product is used. The tank may then be emptied and refilled, or the chlorinated water can be held until the chlorine dissipates or is diluted down to less than 2 mg/L and coliform tests have shown the water to be safe to drink. If the tank is to be emptied, contact DEQ to determine the proper means of disposal of the chlorinated water.
- A solution of 200 mg/L available chlorine is applied directly to the surfaces of all parts of the storage facility that would be in contact with water when the storage facility is full to the overflow elevation. The chlorine may be applied with a brush or spray and must be in contact with the surfaces for 30 minutes. After the 30 minutes, the tank can then be filled with water. Note application of the 200 mg/L chlorine solution requires safety equipment and procedures not typically utilized by small water system operators.

Once the chlorine has returned to less than 2 mg/L and coliform tests have shown the water to be safe to drink, the water from the tank can be turned back into the distribution system.

#### ***6.2.4 Substituting Hypochlorite for Gas Chlorine***

Gas chlorine is 100 percent chlorine. Hypochlorite, however, may range from about four percent to over 60 percent. If a gas chlorinator malfunctions, hypochlorination may be used instead. To add the proper amount of disinfectant, the amount of chlorine in the product used must be taken into consideration. The feed rate for the gas chlorine in pounds per day (lbs/day) must also be known.

The following example illustrates how this calculation would be made:

If calcium hypochlorite with 65 percent available chlorine is used to replace a gas chlorinator which normally adds 4.2 lbs of chlorine per day, how many pounds of the hypochlorite needs to be added?

$$\begin{aligned} \text{lbs of hypochlorite} &= \frac{4.2 \text{ lbs chlorine}}{4.2/65\%} \\ &= 6.46 \text{ lbs} \end{aligned}$$

So, 6.46 lbs of 65 percent hypochlorite would need to be added each day. The batch-mix of hypochlorite and water would need to be prepared and the solution-pump feed rate set to obtain the desired dosage of chlorine.

#### ***6.2.5 Chlorine Safety***

Chlorine, in any form, can be a difficult and hazardous chemical to handle in the concentrations used in water treatment. All personnel should be thoroughly aware of chlorine's hazardous properties. All personnel handling chlorine should know the location and use of the various pieces of protective equipment and be instructed in safety procedures. In a moist atmosphere, or in contact with any moisture, chlorine becomes highly corrosive and is especially destructive to electrical equipment. When combined with the moisture in mucous membranes of the nose and throat, and with the fluids in the eyes and lungs, a very small amount of chlorine gas in the air can be very irritating and can cause severe coughing. Heavy exposure can be fatal.

Chlorine gas leaks may be detected by passing an ammonia-soaked cotton swab near the suspected area. If chlorine gas is leaking and comes in contact with ammonia, a white smoke appears. Do not spray ammonia on the leak, because too much white smoke will be formed to see the leak area and may fill the room so that even the exit is difficult to find. If a chlorine cylinder is leaking, it should only be handled by a person equipped with and trained to use a proper self-contained breathing apparatus (SCBA) in good operating condition. Canister type gas masks are usually inadequate and ineffective in situations where chlorine gas leaks occur and are therefore not recommended for use under any circumstances.

Chlorine gas storage rooms and rooms where chlorine gas is used are required to have mechanical exhaust systems that draw air from the room at a point no higher than 12 inches above the floor. This low height is necessary so the exhaust fan will remove the settling chlorine gas from the room.

The chlorine room should have a solid door opening to the outside which is equipped with panic hardware. A window installed in the wall separating the feed room and the tank room is also needed. The switch for the room light and the exhaust fan should be located outside the tank storage area. Empty tanks, tanks in use and back-up tanks must be restrained using a chain or other means so that they cannot be knocked over.

Each water treatment facility should have a formal safety program with routine hands-on training in use of the safety equipment. Emergency procedures should be established for response to chlorine gas leaks. These procedures should include notification and control of affected persons nearby as well as appropriate first aid

procedures. Police and fire department personnel should tour the facility during normal operations to locate hazardous areas.

Sodium and calcium hypochlorite are not as hazardous as gaseous chlorine and therefore are easier and safer to handle. This certainly should be one of the major considerations for a small system when determining which form of chlorine to use. Personal protective equipment (mask, apron, gloves) should be used when handling hypochlorite since it can cause damage to eyes and skin upon contact. If spilled on skin, the affected area should be washed quickly with large amounts of water.

Hypochlorite solutions are very corrosive. Large volumes of water should be used to wash-down spills. Hypochlorite compounds are non-flammable; however, they can cause fires when they come in contact with organics (oily rags) or other easily oxidizable substances.

### **6.3 Ultraviolet Light (UV)**

UV radiation is effective against pathogenic parasites such as *Giardia* and *Cryptosporidium* and some bacteria, but is not as effective against most viruses. DEQ will evaluate each situation where UV is proposed to determine if it would be appropriate. Another type of disinfection along with UV may be required.

In the process of UV disinfection, water flows by or around a UV lamp and the energy from the lamp inactivates the pathogenic organisms. Since UV is not a chemical agent, it produces no residual.

The main advantage of using the UV process is its simplicity. It does not have any impact on the environment and aquatic life, and it takes very little space. In addition, required contact times are seconds rather than minutes. The equipment is simple to operate and maintain if the apparatus is cleaned properly on a regular basis. Also, customers sometimes favor it because it imparts no taste to the water.

Disadvantages of using UV light are that water with suspended solids, color, turbidity, and soluble organic matter can react with or absorb the UV radiation and reduce the disinfection performance. The unit also does not leave a residual, so it provides no protection in the distribution system. As with all lamps, the UV bulb loses its intensity over time. If the UV lamp is not properly replaced or maintained, it may not transmit enough energy to kill pathogenic organisms. The most important maintenance procedure is to keep the lamp clean and replace it on a regular schedule so the minimum intensity required is always maintained. Some UV systems may be equipped with a shutdown switch if the lamp intensity drops too low. This would concurrently shut off the power to the well.

### **6.4 Other Disinfectants**

There are several disinfectants other than chlorine and UV light which are available to public water supply systems. Some are more appropriate for large systems with extensive distribution piping, and some are relatively new and as yet untried in small system installations. A brief overview of a few of the more common disinfectant alternatives is provided here.

#### **6.4.1 Ozone**

Ozone (O<sub>3</sub>) is a very powerful oxidant. DEQ allows ozonation systems to be used in treatment for color, taste and odor, organics, algae, cyanide, hydrogen sulfide, iron, manganese, heavy metals, detergents, and as a preliminary disinfectant. It must be followed with chlorination to provide a disinfectant residual in the distribution system.

Since ozone cannot be stored, it must be generated on-site as needed. It is created by passing oxygen (ambient air or liquid oxygen) through high voltage current generated by electrodes. The ozone gas is then bubbled up through a contactor apparatus to disperse it in the water.

Ozone is a bluish, toxic gas with a pungent odor and is considered hazardous to health at relatively low concentrations in air. Because of the great energy costs of running the generation system, ozone disinfection may not be practical for small systems.

### ***6.4.2 Mixed Oxidants***

A relatively new disinfection process is available and may be most appropriate for small water systems. The process uses salt and generates a mixture of oxidants on-site.

Passage of an electric current through a continuous-flow brine (salt) solution results in generation of a mixture of ozone, chlorine dioxide, hypochlorite ion, hypochlorous acid and elemental chlorine. A solution containing these oxidants is then injected into the water. This mixture of oxidants is an effective disinfectant, but the relative amounts of the individual oxidants are difficult to measure.

Special approval from DEQ is needed to install this type of system. Equipment costs for mixed oxidant treatment systems are greater than for chlorine systems.

### ***6.4.3 Chlorine Dioxide***

Chlorine dioxide (ClO<sub>2</sub>) is also a powerful oxidant generally prepared on-site. It is used as an initial oxidant for water having high levels of humic or fulvic acids. These naturally occurring organic compounds are precursors to a disinfection by-product called *trihalomethanes*. In water with certain other characteristics, chlorine dioxide may form other by-products which may cause adverse health effects in some people.

Chlorine dioxide is capable of oxidizing iron and manganese, removing color, and lowering the potential for forming trihalomethanes. It also oxidizes many organic and sulfurous compounds that cause taste and odor problems.

Because it must be generated on-site, the investment in equipment and the requirements for skilled operation may make this disinfectant unsuitable for small systems.

## **6.5 Treatment for Common Chemical and Physical Contaminants**

### ***6.5.1 Nitrate and Nitrite***

When a laboratory analyzes a water sample for nitrate and nitrite, the combined concentration of the two compounds is usually reported. The concentration is expressed as "Total N". The combined concentration is normally used because nitrite is extremely unstable and rapidly converts to nitrate. Public water supply systems with total N concentrations over 0.5 mg/L must have their water checked for the concentration of nitrite.

Levels of nitrate greater than 10 mg/L and levels of nitrite above 1 mg/L pose an acute health threat to infants less than six months of age and unborn children. The health effect is caused by interference with the ability of blood cells to carry oxygen, which leads to a condition called *methemoglobinemia* (blue baby syndrome).

Nitrate/nitrite in well water may indicate natural geologic contamination. It also could indicate contamination from agricultural activities or human or animal waste disposal percolating into groundwater.

Nitrate is most commonly removed using either reverse-osmosis membrane filtration, electro-dialysis reversal, or an ion-exchange process, much like a water softener. In the softening process, water is passed through a tank which contains resin, and the nitrate ions are adsorbed onto the resin and exchanged for another ion. The resin is usually a synthetic plastic and is specifically designed to remove nitrate. The treatment process usually consists of pre-filtration, ion exchange, and disinfection.

The ion exchange process is relatively insensitive to flow rates. The ion exchangers that are recharged with sodium chloride (salt) may increase the sodium level in the finished water. Sodium is often used because of its low cost, but high sodium residual is unacceptable for individuals with salt-restricted diets. This problem can be avoided by using other exchange materials, such as potassium chloride. Ion exchange waste is highly concentrated and requires careful disposal. The process is rather simple to operate and so can be used by small systems.

### ***6.5.2 Iron and Manganese***

Excessive amounts of iron and manganese in drinking water are objectionable because they stain clothes, fixtures, and encourage the growth of iron bacteria and other nuisance bacteria. For these reasons iron should not exceed 0.3 mg/L and manganese should not exceed 0.05 mg/L.

Iron bacteria form slimes on pipe walls. When the slime breaks away it causes red water (iron) and black particles (manganese) which also stains fixtures and clothes.

If the water contains less than 1.0 mg/L iron and less than 0.3 mg/L manganese, the use of phosphate ***sequestering agents***, followed by chlorination, can be an effective and relatively inexpensive treatment. Adding a sequestering agent will keep the iron and manganese in suspension so it will not precipitate and cause staining problems. Chemical suppliers can assist in the selection of the best product. Plans for the treatment system must meet the design standards set forth in circular WQB1 and DEQ must review and approve all treatment prior to installation.

Iron and manganese can also be removed by oxidizing them to form insoluble precipitates and filtering the precipitates out of the water. Chlorine is often used to oxidize these contaminants. However, potassium permanganate can also be used, but the dosage must be exact. An inadequate dosage will leave some of the iron or manganese unoxidized, and too much will cause a pink color in the water going to the distribution system. Sometimes a greensand is used as the filter material and it also oxidizes the iron and manganese to their insoluble form. The greensand is capable of performing both the oxidizing and the filtration steps in one process. Filtration is often provided by a pressure sand filter.

***Aeration*** (spraying or bubbling the water over trays) can also be used to oxidize iron: the higher the pH, the faster the reaction. Some holding time must be provided for the reaction to take place and for the iron particles to settle out. The remaining particles are taken out by a filtration process.

Iron and manganese can also be removed using an ion exchange process, but if the water contains much dissolved oxygen, it could foul the resin. Specific resins are available for iron and manganese removal.

### ***6.5.3 Taste and Odor***

People often get used to the taste of water they are exposed to every day. However, water operators will hear from their customers very quickly if these taste and odor characteristics change. Some tastes and odors make water undrinkable. Tastes and odors have been described as bitter, oily, dry, metallic, musty, earthy, fishy, grassy, or hay-like. Some water may even smell like rotten eggs—a result of having hydrogen sulfide gas in the water.

Although bad taste and/or odor can be in safe drinking water, it may not be palatable (good tasting). It is the operator's job to make the water acceptable to customers' taste. When people do not like the taste they may not be supportive of needed changes in the water system, they may begin to buy bottled water or they may get water from a supply that is less safe, but tastes better.

## ***Chapter 6: Treatment of Groundwater***

---

Tastes and odors go hand-in-hand. It is difficult for people to tell which of their senses is being affected. There are really only four true tastes—sour, sweet, salty, and bitter. Other variations on these are actually caused by odor.

Surface water sources may be much more subject to tastes and odors because of exposure to algae, municipal waste waters, agricultural runoff, vegetation die-off, and chemical spills. Groundwater tastes and odors may be caused by dissolved gases, biological growths, or by inorganic or organic contaminants.

Organic contaminants most often are the result of a chemical spill or of unauthorized dumping. In one area of Montana, water systems are having to abandon groundwater supplies 1 ½ miles from a site where organic solvents were dumped into a septic tank.

A variety of contaminants have been introduced to drinking water through ***cross-connections*** (See Chapter 8). Often the first warning the operator has of such a condition are the complaints about a “chemical” or “pesticide” taste or odor in the water.

In the distribution system, microbiological growth in dead end lines or in sediment in the bottom of a storage tank could be a cause of taste and odor problems. A good preventive maintenance program of routine hydrant flushing and storage tank cleaning can prevent these problems from occurring.

Sometimes the problem may be traceable to an individual customer’s plumbing. Stale water in some of the lines, inadequate cleaning of faucet aerators or bacterial growth in a faucet-mounted filter may all contribute to undesirable tastes and odors.

As mentioned in Section 6.5.2, iron and manganese may cause taste and odor problems. Applicable treatment techniques are covered in that section.

Aeration is often used to remove a variety of volatile taste and odor contaminants. This process is known as degasification. Gases like hydrogen sulfide (rotten egg smell) are easily removed. The aeration process may take place by moving air through the water (bubbling air through a diffuser) or by passing the water through air (spray nozzles, aeration trays, etc.). A process called packed column aeration (PCA), or air stripping, combines both processes by flowing water over columns of support media (or packing) while forcing air up through these columns of media. This process improves the removal efficiency of the volatile substances.

***Granular activated carbon (GAC)*** is also one of the best available treatments for volatile organics. Water is run through a stationary bed of GAC and the contaminant particles are adsorbed onto the surface of the carbon. Although GAC is quite useful in removing volatile organics removal efficiency varies for other types of organic compounds. The process would be rather expensive for very small water systems as it requires monitoring the performance of the filter and periodic replacement of the filter media.

Both chlorine and potassium permanganate can be used to oxidize odor producing compounds. These are often more useful in water systems dealing with surface water taste and odor problems.

### ***6.5.4 Sulfate and Sulfide***

Hydrogen sulfide gas sometimes is contained in well water and it gives off a very characteristic rotten egg smell. This can usually be removed by an aeration process.

Sulfate generally becomes a problem when it exceeds 500 mg/L because it can cause laxative effects for persons not used to drinking water with these concentrations. Sulfate, in combination with other constituents, may give a bitter taste to water. Sulfate can be removed to some acceptable levels using reverse osmosis treatment.

### **6.5.5 Fluoride**

Fluoride has both beneficial and harmful levels. A fluoride content of approximately 1 mg/l in drinking water is considered beneficial for the prevention of tooth decay. However, levels of fluoride exceeding 2.0 mg/l (the secondary maximum contaminant level) may cause tooth mottling. Levels above the maximum contaminant level (4 mg/l) may cause skeletal problems. For this reason, the concentration of fluoride in drinking water should be carefully monitored.

Fluoride is usually added to small water systems using a saturated solution of sodium fluoride and injecting it into the water with a solution feed pump, much like hypochlorination. For systems that add fluoride, DEQ requires daily monitoring and submission of sample results monthly (refer to Chapter 2 and the *Public Water Supply System Regulatory Summary*).

Fewer than 10 public water systems in Montana have an excess of fluoride in the water they serve to customers. Fluoride removal is an expensive process, especially for small systems. One Montana system is currently using a reverse osmosis process to reduce the fluoride levels in their drinking water to below the maximum contaminant level. An ion exchange process using activated alumina has been successfully used in some other states for fluoride removal.

### **6.5.6 Sand and Sediment**

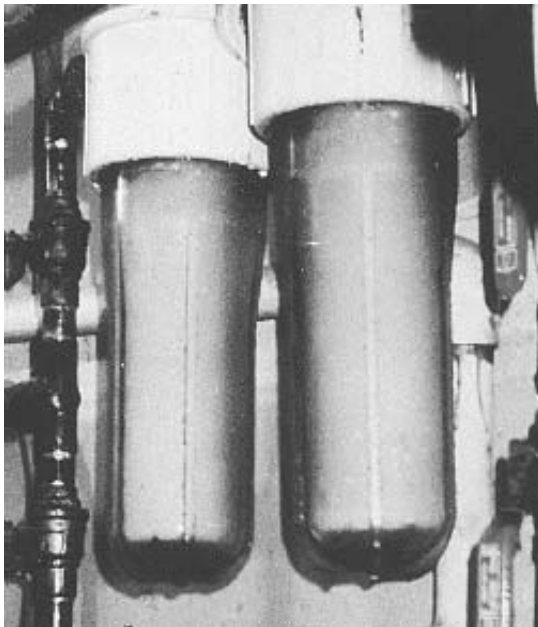

**Figure 6.5.6. Cartridge Filters**

Well water will sometimes contain sand or sediment. This material could not only cause cloudy unappealing water, but it could also settle at low points in the distribution system or cause clogging problems in customer's plumbing systems. Consequently, some small water systems use either a sand separator or a cartridge filter to trap this material before it enters the distribution system.

Sand separators function by generating a centrifugal force in a cylindrical piece of equipment which forces the sand to the wall of the separator and down to a collector area. The sand is then periodically flushed from the equipment.

Cartridge filters (Figure 6.5.6) usually contain pleated fabrics, membranes or strings wrapped around a filter element. A variety of filters are available with different pore size ratings (0.3 to 80 um) and materials. Often a pre-filter with a pore size of greater than 10 um precedes a finishing filter with pore sizes in the 1 to 5um range.

Cartridge filters and sand separators are both well suited for small water systems. However, both must be routinely checked and cartridge filters must be periodically replaced. By concentrating particles in one area, cartridge filters can also contribute to growth of non-coliform bacteria which may interfere with routine monitoring of the bacteriological quality of the water.

### **6.5.7 Corrosivity**

Lead and copper enter drinking water mainly from the *corrosion* of household plumbing. Some very old homes still have lead pipe service lines. Prior to 1986, lead solder was still being used to join copper drinking water pipe. When corrosive water stands for a long period of time in a household plumbing system, lead and copper are likely to leach into the water.

There are two common types of corrosion — corrosion caused by chemical dissolution of metals, and corrosion caused by electrochemical dissolution of two dissimilar metals.

A number of factors can affect the chemical corrosiveness of the water:

- An increase in temperature will increase corrosion rates because at warmer temperatures chemical reactions occur more quickly.
- A pH in the acidic range or above about 7.8 in the alkaline range can cause corrosion.
- Water with a pH above 8 and an alkalinity greater than 100 mg CaCO<sub>3</sub>/L is frequently highly corrosive toward copper.
- A low calcium concentration may cause water to be more corrosive.
- Water with a higher conductivity is often more corrosive than water with a lower conductivity.



**Figure 6.5.7. Corroded Pipe**

Corrosion control treatment schemes must be based on the water chemistry of the source water. Treatment may vary from addition of corrosion inhibiting phosphate solutions, to alkalinity and pH adjustments.

### **6.5.8 Hardness**

Some consumers use hardness as a measure of the quality of the water they receive. *Hardness* is a characteristic of water caused mainly by the presence of calcium and magnesium. Excessive concentrations of these chemicals tend to inhibit the cleaning action of soap, cause deposits in boilers and hot water heaters, and interfere with many industrial processes. Customers often complain about the difficulties in doing the laundry and washing dishes. Also, excessively hard water can coat the insides of pipes and distribution mains and eventually restrict flow.

Hardness is often expressed in terms of mg/L as calcium carbonate (CaCO<sub>3</sub>). There are different opinions on where the dividing line is between soft and hard water, but some textbooks define hard water as water with a hardness greater than 100 mg/L as calcium carbonate.

The most popular method of hardness removal is the ion exchange process. Many customers might have one of these units in their home and refer to it as a “water softener” (see figure 6.5.8). This process also has some other benefits such as removal of small amounts of iron and manganese, and radioactivity that might be in the water. On the negative side, soft water can increase the rate of corrosion of metal pipes. Bacteriological growth in home water softeners has also contributed to non-coliform interference in microbiological quality monitoring samples.



An ion exchange process can be used centrally by a public water supply to soften all the water for their customers. In the ion exchange process, water is passed through the resin in the treatment unit and the resin exchanges sodium ions for calcium and magnesium. The calcium and magnesium remain trapped on the resin

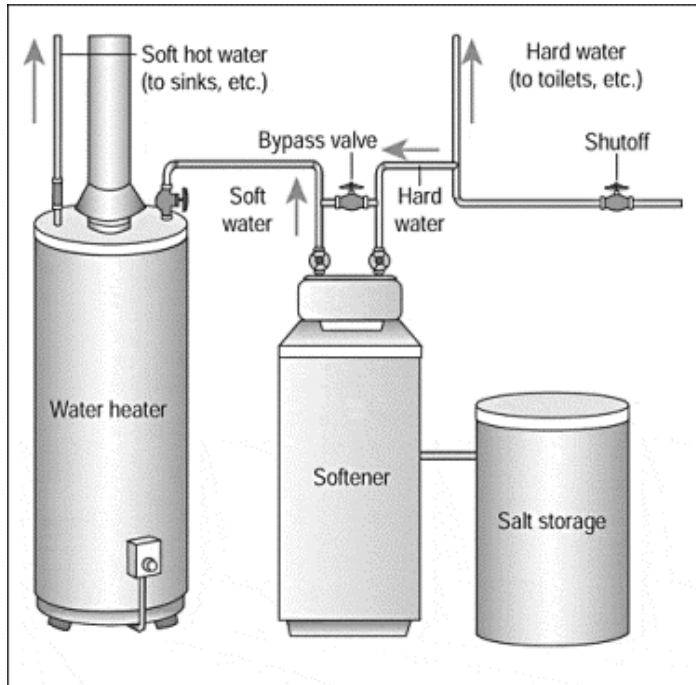

**Figure 6.5.8 Typical household water softening or conditioning system**

until the system is backflushed with a high concentration of salt (sodium chloride) and the resin is again recharged with sodium ions. The brine solution is then flushed out of the unit and the ion exchanger is again ready to begin trapping calcium and magnesium and exchanging it for sodium. Most home softeners simply discharge their brine solution to the sewer. If the ion exchange process is conducted by the water system the disposal of large quantities of brine must be addressed in the design of the treatment system.

Since the ion exchange process exchanges calcium and magnesium ions for sodium ion, there are some concerns about raising the levels of sodium in the water served to customers. This could be a problem for persons on sodium restricted diets. The level of sodium in the water supply should be reported annually to customers.

## Chapter 7: Distribution Systems

The distribution system consists of booster pumps, pipes, meters, storage tanks, control valves, and hydrants. This part of the system is often neglected because much of it is underground and out of sight, but it needs and deserves almost as much operator attention as source and treatment facilities.

An adequate distribution system is able to provide a sufficient amount of safe water to all users at a pressure that will satisfy normal needs. It also provides water without undue water loss.

More information on distribution systems, critical to those directly involved in placement, repair or  
*Distribution System Operations and Maintenance.*

Even in a metered system, not all water coming from the well can be accounted for. Some may be lost because of leaks in the system, some may be discharged through hydrants as part of a flushing program, and some may evaporate from storage tanks or be used fighting fires. This portion is usually referred to as unaccounted-for water.

The total amount of water delivered to the customers is usually measured in million gallons per day (mgd), or in gallons per capita day (gpcd) which is the total number of gallons divided by the number of persons served.

An operator of a small water system may not be involved in the design, construction or repair of the distribution system. However, to properly maintain the system it is important operators are familiar with all parts of the system and the effects they may have on the quality of the water served to customers.

### 7.1 System Components

#### 7.1.1 Piping Materials

A variety of pipe materials are available for use in a public water supply system to carry water under pressure. They include plastic, ductile iron, steel, concrete and asbestos-cement. Service pipes—those running from the distribution system to a customer—may be made of copper, plastic, iron, steel, or brass.

All components used in a water distribution system must conform to the latest standards issued by the American Water Works Association (AWWA), or by the ANSI/NSF standards for potable water when AWWA standards do not exist (e.g., for less than 4 inch diameter pipe). These organizations have established standards for water supply materials which ensure the materials used will not leach contaminants into the drinking water and meet minimum strength criteria. Used materials can be reused if they meet the standards and have been restored to practically original condition.

The amount of water a pipe can carry is a function of its size and the smoothness of the interior surface. The following are brief summaries of the various types of pipe commonly found in water systems:

**Ductile Iron Pipe**—A system may have two types of cast iron pipe—grey cast iron and ductile iron. Although it is no longer manufactured, grey cast iron over one hundred years old is still in use in some systems. It is tough and easily tapped. Ductile iron is similar but stronger, less rigid, lighter, and can offer better corrosion resistance. Ductile iron is lined on the inside to prevent corrosion, including *tuberculation*, and to provide a smoother pipe interior which will provide less friction to the water flowing through. On the exterior, bituminous coatings or a polyethylene wrap may be used to reduce corrosion caused by aggressive soils.

**Steel Pipe**—Steel pipe is lighter than ductile iron and has a high tensile (pulling or stretching) strength, some flexibility, is easily installed and jointed, low in cost, readily welded together, and easily assembled, handled and transported. However, it is more subject to corrosion and therefore must be lined or coated inside and

## ***Chapter 7: Distribution Systems***

---

out. Coatings or linings might be cement or epoxy material and the exterior could be coated with epoxy or mastic or with a protective plastic wrap. Galvanized steel pipe has been coated with zinc.

**Concrete Pipe**—Concrete pipe is durable, has good internal corrosion resistance, low maintenance features and is easily installed. Prestressed concrete (also called reinforced concrete) is the most common type and has reinforcement with wire strands to provide more resistance to loads and pressure. Disadvantages of concrete pipe are it is heavy, difficult to tap, needs special fittings, and may deteriorate in aggressive soils. It is available in sizes 12-inch diameter and larger.

**Asbestos-Cement (AC) Pipe**—Asbestos-cement pipe was quite popular until it was found, under certain conditions, it can release asbestos fibers which may be harmful to people's health. Health concerns are mainly with airborne asbestos, but research is still investigating the effects of ingestion. Airborne asbestos affects those in the pipe manufacturing business and those involved in pipe replacement, repair, or tapping.

AC pipe will not burn, deteriorate, or corrode and has a high tensile strength. It is light (about half the weight of ductile iron pipe), very smooth inside so offers little friction to water flow, and it is easily tapped, cut and machined in the field.

Disadvantages of using AC pipe include easy breakage when bent and vulnerability to impact damage. It is also difficult to locate when buried and can't be thawed using electrical methods because it will not conduct electricity. Asbestos fibers may leach out of the pipe when it is transporting very soft water. Respirators should be worn when there is the possibility of asbestos fibers becoming airborne during placement or repair.

**Plastic Pipe** (Figure 7.1.1)—The use of plastic pipe has become very popular in many parts of the country. The types of pipe in general use are PVC (polyvinyl chloride), PE (polyethylene), and PB (polybutylene).

Plastic pipe has very low frictional head losses because it has such a smooth interior surface. It is light and easy to handle and join. The pipe materials are not subject to corrosion, and are generally less expensive than other types of pipe.

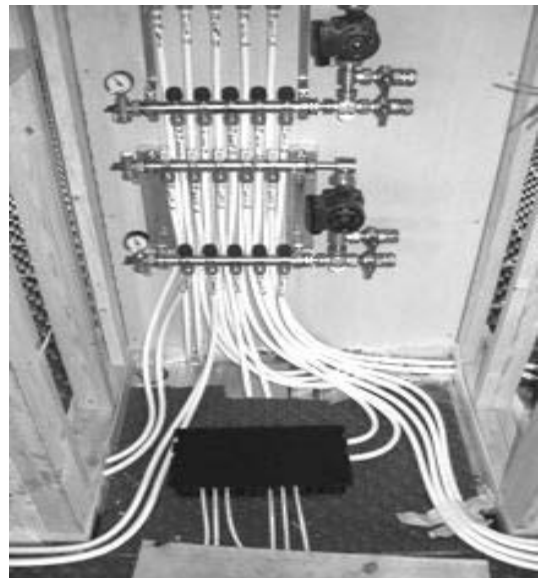

**Figure 7.1.1. Plastic water pipes**

**Service Lines**—A wide variety of materials have been used for service lines but the most common are copper and polyethylene. In corrosive water, lead pipe service lines may need to be replaced to eliminate lead in drinking water which has leached from the pipe interior. Corrosion control treatment may also be an effective remedy for lead leaching.

### **7.1.2 Valves**

Valves are a very important part of the distribution system because they regulate the flow of water, reduce pressure, provide air and vacuum relief, blow off or drain water from parts of the system and prevent backflow.

The operator should know the locations of these valves so they can be used when necessary. Each water system should have a map available with the location of the valves clearly marked. It is important that the access to the valves not be compromised by other facilities. For example, access to some valves has unknowingly been covered during a street repair process.

Most valves will need to be exercised at least on an annual basis. If not, they may become stuck and will be inoperable when really needed. This valve exercising process should be geared into a routine maintenance plan.

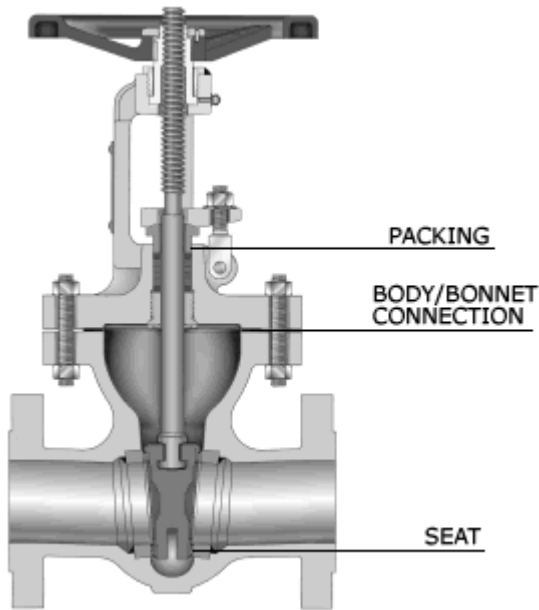

**Figure 7.1.2a. Gate Valve**

Valves of any size need to be operated slowly. **Water hammer** is caused by closing the valve too quickly. When water is suddenly stopped, shock waves are generated, which cause large pressure increases throughout the system. These shock waves travel quickly and can cause extensive damage, sometimes splitting pipes or blowing fittings completely off the system.

Frequently in the operation of valves, conditions cause a partial vacuum or void to occur on the downstream side of a valve. These voids will fill with low-pressure vapors from the water. When these pockets implode or collapse, they create a mechanical shock causing pockets of metal to break away from the valve surface. A noisy or vibrating valve may be an indication that **cavitation** is occurring, which will eventually result in leaks and a valve unsuitable for service.

**Gate valves** (Figure 7.1.2a) are used to isolate sections of the distribution system to permit emergency repairs without interrupting service to large numbers of customers. In the gate valve, a sliding flat metal disc is moved at right angles to the

direction of flow by a screw-operated stem. The disc can be taken completely out of the flow chamber—therefore, the valve provides very little resistance to flow when it is opened. Various types of **rotary valves** are available including the ball, butterfly, and plug valves. Usually, a 90 degree rotation movement is used with a notch, arrow or other indicator to show valve positions.

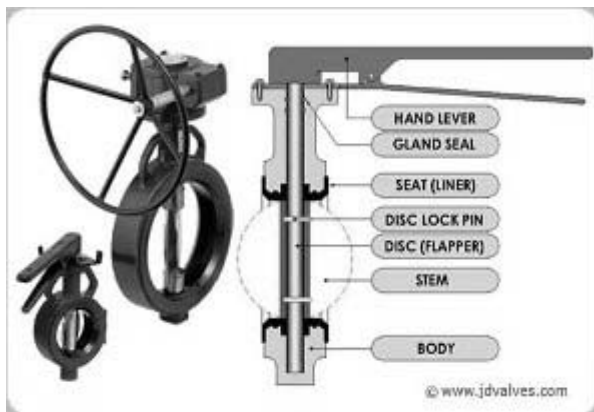

**Figure 7.1.2b. Butterfly Valve**

In a **ball valve**, the movable part is a ball with a cylindrical hole bored through it. When the ball is in one position there is a straight passage through the valve, but when it is rotated 90 degrees the flow is blocked. Ball valves should be operated either closed or opened all the way.

The **butterfly valve** (Figure 7.1.2b) has a disc which fills the full diameter of the pipe. The disc rotates on a shaft to allow the flow of water.

**Plug valves** (Figure 7.1.2c) are most often used extensively as corporation stops on service lines. They may have a tapered or cylindrical plug with an opening through the side which can be turned to open, restrict, or close the flow.

**Globe valves** (Figure 7.1.2d) are very efficient in either flow or pressure regulation. A disc is raised or lowered onto a seat as in the common home faucet. The water flow is stopped when the disc contacts the seat. In a diaphragm valve, a flexible piece (usually rubber or leather) inside the valve's body can be adjusted up or down using an attached stem to block or regulate the flow of water.

Back-flow prevention or cross-connection control can be accomplished with the use of some valves specifically designed for that purpose. More information is provided in Chapter 8: *Cross Connections and Backflow Prevention*.

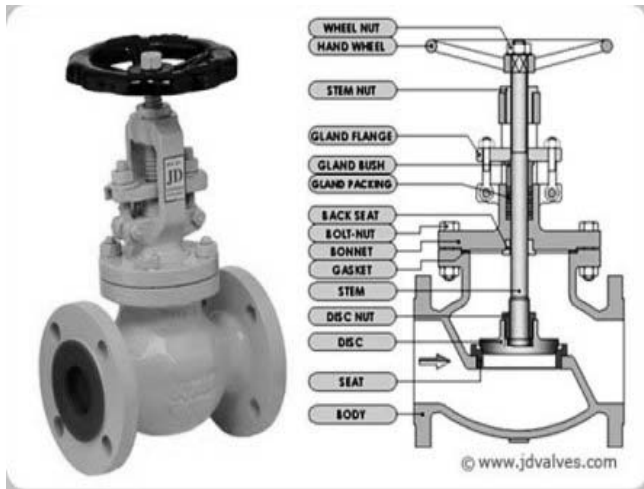

**Figure 7.1.2c. Plug Valve**

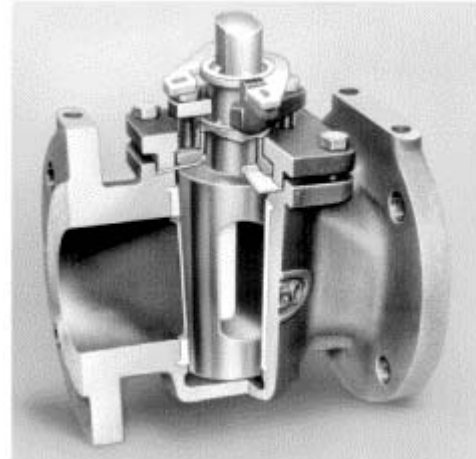

**Figure 7.1.2d. Globe Valve**

Most valves do not provide an absolute stoppage of water. Most leak under some circumstances, many just because of age and deterioration. Leaking valves have been responsible for contamination of public water supply systems when they were used as the only separation barrier between the water system and a non-potable supply. Non-potable supplies have included private well systems, transmission mains containing untreated surface water and wells used for irrigation.

### **7.1.3 Pressure Reducing Valves**

Pressure reducing valves reduce the water pressure by restricting the flow. Pressure on the downstream side of the valve regulates the amount of flow permitted through it.

This type of valve is usually of the globe design with a spring-loaded diaphragm which sets the amount of the opening. As downstream pressure is exerted against the diaphragm, the spring is compressed, moving the valve element toward the seal, thereby limiting the flow. If the downstream pressure drops, the spring will open the valve element and provide more flow.

These valves allow distribution systems to maintain pressures to the customers in the desirable 50 to 80 psi range. Pressure regulators are especially valuable in the mountainous portions of Montana where elevation differences produce great differences in pressure within the distribution system.

### **7.1.4 Fire Hydrants**

If the water system is designed to provide fire protection, the water lines and the hydrant connections to the distribution system must be a minimum of six inches in diameter. The location and spacing of hydrants is specified in State design standards. Within a residential environment they should be at every street intersection. Flushing hydrants may be smaller than 6-inch diameter, but must not have fire-fighting compatible connections. Hydrant maintenance and operation is covered in Section 7.4.2.

### **7.1.5 Storage Reservoirs**

Small water systems may have a small amount of storage in the form of a hydropneumatic tank—either a standard pressure tank with an air/water interface, or a captive air tank. Other systems might have ground level concrete or steel storage tanks or elevated steel tanks which serve the system by gravity.

## ***Chapter 7: Distribution Systems***

---

Small hydropneumatic pressure tanks are used to maintain pressure within the distribution system and to prevent well pumps from cycling too frequently. These tanks are captive air tanks and are covered in more detail in Section 5.7.

Larger hydropneumatic tanks use on-site, permanent, air charging devices to maintain the needed air pressure within the vessel. The tank should have a sight glass so the air/water ratio in the tank can be observed and adjustments made.

Concrete or steel storage tanks will provide a greater amount of storage capacity than a hydropneumatic tank and may provide sufficient fire flows. They also will continue to operate for a period of time during a power outage.

Many small water systems have elevated steel tanks (Figure 7.1.5a) or ground level concrete or steel tanks.



**Figure 7.1.5a. Elevated Steel Tank**

These storage facilities may have openings which could allow contamination to enter, so it is vital to be certain these avenues are closed. All water distribution storage tanks should be covered to protect against contamination. All of these tanks should be equipped with vents, an access hatch, overflow outlets and drains. The vent(s) should be turned down and screened to prevent the entrance of dust, birds, insects and other vermin. The drain and the overflow pipe should also be screened and designed with a splash pad or other means to prevent erosion when overflow or drainage occurs. The access hatch should have an overlapping, gasketed, locking, shoe box-type lid (Figure 7.1.5b).

During a long winter cold spell, ice formation may occur in both ground level and elevated storage tanks. The icing may be

severe and thick accumulations may collect on sidewalls or may create a giant iceberg which floats inside. This can cause tremendous damage to the sides of the tank and any appurtenances inside such as water level control devices or ladders. Ice formations can be minimized by continuously running water in and out of the tank and fluctuating the reservoir water levels. This flow of fresh water minimizes the formation of ice and replaces the colder water in the tank.



**Figure 7.1.5b. Shoebox Lid on Tank Access**

Disinfection of tanks after construction, repairs, or inspections is covered in Chapter 6: *Treatment of Ground Water*.

### **7.1.6 Bulk Water Hauling Stations**

Bulk water stations provide a valuable service to those outside of the distribution system. They also may be a good source of revenue. However, it is vitally important the water system is protected against contamination from users of the bulk station.

Bulk water may be purchased and hauled for several reasons: home drinking water, livestock water, irrigation, construction, or mixing of pesticides or other chemicals. Therefore, it is critical substances from the users tank are prevented from being back-siphoned (sucked) into the public water supply system. It is also important to protect other users of the bulk station from contamination carried by the fill hose. Fill hoses may become contaminated if they are allowed to touch the ground or come into contact with solutions in the haulers tank.

Preventing contamination of the public water supply system and fill hose can be accomplished by providing an air gap. A device to create an air gap (Figure 7.1.6) can be constructed.



**Figure 7.1.6. Air gap devices**

### **7.1.7 Booster Stations**

A booster pump is used to increase the pressure in the mains on the discharge side of the pumps, or to supply water to an elevated or higher level storage tank. They are also often used to supply water to a service area at a higher elevation by taking water from storage to pressurize the distribution system.

Booster pumps are centrifugal pumps and care should be used in their operation. An operator should be concerned about three critical points: installation, alignment and protection for operators from moving parts. If the initial installation and the alignment are properly done, the pump should give few problems and require little maintenance other than routine checking of the packing and lubrication of bearings. Manufacturer's instructions must be followed for packing and lubrication requirements.

Protection from moving parts is critical as unprotected and rapidly rotating shafts can capture loose clothing and cause severe injury.

As for all pumps, frequent inspection of the pump for heat, unusual vibration and noise are important parts of a maintenance program.

More information on maintenance and troubleshooting centrifugal pumps is found in *Water Distribution System Operation and Maintenance*.

### **7.1.8 Looped Systems and Dead End Mains**

Water lines should be installed to loop back into another part of the distribution system. This allows circulation of water to all users. Dead ends should be avoided. The lack of movement of the water in these lines will cause stagnation and result in the growth of slimes and bacteria, and development of taste and odor problems.

If it is necessary to have a dead end line, a fire hydrant or a flushing hydrant should be installed on the end of the line so stagnant water can be routinely discharged. The hydrant should be large enough to generate a flow of 2.5 feet per second in the line for thorough flushing.

### **7.1.9 Leak Detection Program**

Leak detection programs are an effective way to reduce operating and maintenance costs. If leaks can be detected when they are small, the system may save many dollars, hours of work and possible property damage. Leaks not only waste water, but may create an environment around the pipe which increases corrosion. Once corrosion develops pinhole leaks in the pipe, contamination can be drawn into the system when the pressure in the pipe is reduced.

Leaks are not easy to locate. Of course, the most obvious method is to look for wet spots on the ground. However, in some Montana soils the leak may never get to the surface. In some soils, the leak may surface several hundred feet from the actual point of discharge from the pipe.

Specialized listening devices are sometimes used to locate a leak. The simplest method is to hold a steel bar against the pipe when no user demand is causing flow through the pipe to listen if the sound of flowing water can be heard. Much more sophisticated devices are also available to locate escaping water. There are technical assistance providers and commercial leak detection companies which serve Montana water systems needing leak detection assistance.

If the water system is completely metered, a water balance between the amount produced and the amount billed to customers can sometimes indicate when losses are occurring.

## **7.2 System Pressure and Basic Hydraulics**

### **7.2.1 System Pressure**

A distribution system must not only provide an adequate quantity of water, it also must be designed to provide sufficient pressure to satisfy normal customer requirements. All water mains are sized to maintain a normal working pressure of at least 35 pounds per square inch (psi). However, pressures in the system under normal operating conditions should range between 50 and 60 psi.

The very minimum pressure under all flow conditions, including when water is being drawn off to fight a fire, is 20 psi. Any pressures less than that are unacceptable because they create conditions for potential back-siphonage and contamination of the public water supply system (see Chapter 8: *Cross-Connections and Backflow Prevention*).

Pressures above 100 psi should be avoided to minimize leakage, reduce water consumption, and prevent excessive wear on water-using appliances. When the pressures are this high in a residential setting, pressure reducing valves should be installed on individual homes or on an isolated portion of the distribution system to limit the pressure to less than 100 psi.

### **7.2.2 Hydraulics**

To better understand what is happening to the water in a distribution system, it is helpful to review some of the fundamental principles of hydraulics. **Hydraulics** is the study of liquid in motion and under pressure. The information provided in this manual assumes a general understanding of basic math calculations of multiplication, division, addition and subtraction. Also, it is assumed operators have the ability to use fractions; calculate the area of circles, squares and rectangles; and calculate simple volumes.

To assist with these calculations a reference sheet of commonly-used water and wastewater formulas is available from DEQ.

Additional information on basic mathematics may be obtained through technical assistance providers, seminars and mathematics home-study courses. Contact DEQ for assistance locating any or all of these resources.

#### *Quantity and Velocity (speed of flow)*

The quantity of flow (Q) is the volume of water flowing in a pipe, through a flume or water in a stream passing a specific point in a specific unit of time. The water could be under pressure as it is when confined in a pipe, or unconfined like a stream or flume.



## ***Chapter 7: Distribution Systems***

---

Flow can be expressed in several ways: cubic feet per second (cfs), cubic meters per second (m<sup>3</sup>/sec), gallons per minute (gpm), or million gallons per day (mgd).

The basic flow equation is:

$$Q = A \times V$$

The “A” stands for the cross-sectional area of the flowing stream of water. For example, if the stream is in a rectangular flume, the cross-sectional area is the width of the flume times the depth of the water. If the flow is in a pipe running completely full, the cross sectional area is found by using a formula of the area of a circle.

The “V” in the formula stands for the velocity of flow (speed at which the water is moving) and is usually expressed in feet per second (fps).

The basic flow equation simply states the bigger the pipe (flume, stream, etc.), through which water is flowing and the faster it is flowing, the more water that will be delivered per unit of time.

If area (A) is in square feet (ft<sup>2</sup>) and velocity (V) is in feet per second (ft/sec or fps), flow (Q) is expressed as cubic feet per second (ft<sup>3</sup>/sec or cfs).

$$Q = AV = (\text{ft}^2)(\text{ft}/\text{sec}) = \text{ft}^3/\text{sec} = \text{cfs}$$

Cubic feet per second may be converted into the more common term of gallons per minute (gpm). There are about 7.48 gallons in a cubic foot.

$$\begin{aligned} & (1 \text{ ft}^3/\text{sec})(7.48 \text{ gallon}/\text{ft}^3)(60 \text{ seconds}/\text{minute}) \\ & = 450 \text{ gallons}/\text{minute} \end{aligned}$$

Therefore, one cubic foot per second (1 cfs) equals about 450 gallons per minute (gpm).

To properly operate a water system there should be a meter at each well to measure the flow. If records are kept of this flow, it will be possible to compute the average daily demand and the peak rate of demand. Unusually high water use could be detected by comparing current use to historical records.

The flow of small diameter pipes can also be measured from a hydrant with just a bucket and a stop watch.

For example, if a 5-gallon bucket is filled in 30 seconds:

*First*, convert 30 seconds to minutes  
so it can be used to compute gpm:

$$\begin{aligned} & (30 \text{ sec})(1 \text{ min.}/60 \text{ sec}) \\ & = 0.5 \text{ minutes} \end{aligned}$$

*Next*, calculate Q as gpm:

$$\begin{aligned} Q & = 5 \text{ gallons} \div 0.5 \text{ minutes} \\ Q & = 10 \text{ gpm} \end{aligned}$$

*Pressure Head*

In a tank of water, the weight of water exerts a pressure on the bottom of the tank which we call *pressure head*. The deeper the water, the greater the pressure on the bottom of the tank. This pressure not only exerts itself downward, but also in equal amounts against the sides of the tank. The pressure is dependent only on the height of the water and not on the volume of the tank. For example, the pressure at the bottom of a 10 foot high, 50,000-gallon tank that is full will be the same as the pressure at the bottom of a 10 foot high vertical 1-inch pipe filled to the top. When water is flowing, the pressure head is reduced by frictional losses.

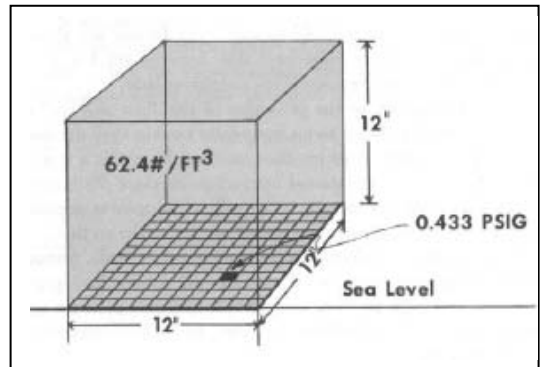

**Figure 7.2.2. Cubic Foot of Water**

Pressure head is commonly expressed either as head (feet of water), or as pressure (pounds per square inch or psi). A cubic foot of water weighs 62.4 lbs (Figure 7.2.2). If the water is in a 12-inch by 12-inch square block, there will be 144 columns of water, 1-inch square, each 12 inches high.

If 144 square inch columns exert a pressure of 62.4 lbs, then one square inch column exerts a pressure of:

$$\begin{aligned} &62.4 \text{ lbs}/144 \text{ square inches} \\ &= 0.433 \text{ lbs/sq. inch or } 0.433 \text{ psi} \end{aligned}$$

So—a head of one foot of water exerts a pressure of 0.433 psi.

If a column of water one foot high exerts a pressure of 0.433 psi, how high a column would it take to provide a pressure of 1.0 psi?

$$(1 \text{ psi})(1 \text{ ft}/0.433 \text{ psi}) = 2.31 \text{ feet high}$$

So, a column of water 2.31 feet high provides a pressure of 1 psi at the bottom of the column.

**The following are examples to show how practical this information can be.**

A. *If a water tank is filled with 10 feet of water, what is the pressure at the top?*

There is no water above that line, so the pressure head will be zero.

B. *What will be the pressure at the bottom when the water depth is 6-feet?*

Given the head of 6-feet:  
 $(6 \text{ ft.})(0.433 \text{ psi/ft}) = \underline{2.6 \text{ psi}}$

C. *What will the pressure be at the bottom of the tank when full (10-feet deep)?*

$$(10 \text{ ft.})(0.433 \text{ psi/ft}) = \underline{4.33 \text{ psi}}$$

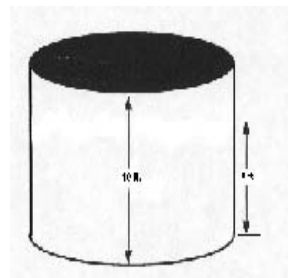

*Frictional loss*

The water operator needs to have a good understanding of the relationship between head loss and pipe diameter. Simply stated, larger diameter pipes will create less head loss per foot of pipe than small diameter pipe. As many metal pipes age, corrosion may cause the frictional losses to increase.

**7.3 Construction and Repair**

Although the small system operator may not be involved in the design and construction of the water system, it is important to understand a few basic facts about this process. Being aware of some of these fundamental concerns will also assist in making sound decisions when system repairs are needed.

**7.3.1 Construction and Minimum Separation Distances**

*Parallel Installation With Sewer Pipes*—Water mains should never be laid in the same trench with sewer pipes. The potential for contamination is too great. State regulations require at least a 10 foot separation between these two systems.

*Water Main Crossing Sewer Lines*—When it is necessary for the water line to cross a sewer line, there must be 18 inches of vertical separation between the water main and sewer line. Also, one full length of water pipe should be laid so that the joints are as far as possible from the sewer. Water mains must be above sewer lines.

*Pipe Bedding*—A continuous and uniform bedding material (gravel, sand) must be provided in the trench for all buried pipe. This will help to prevent future punctures and breakage by large rocks putting excessive pressure on portions of the pipe. Backfill material should be tamped in layers around the pipe to provide adequate support and protection for the pipe. This will prevent undue settling and breakage.

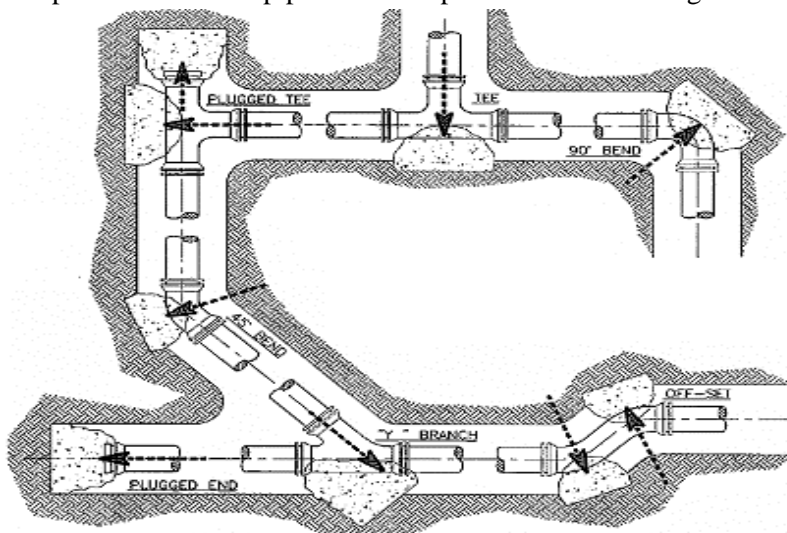

**Figure 7.3.1. Thrust Block Locations**

*Depth of Bury*—All water mains should be covered with sufficient earth or other insulation to prevent freezing. The depth of this cover will vary with the location within the state.

*Thrust Blocks*—Water hammer can cause enormous pressures on portions of the distribution system. Therefore, it is important to be certain thrust blocks are placed to support the pipes and other components at all points where the flow of water changes direction. Some examples of thrust block locations are provided in Figure 7.3.1.

**7.3.3 Preventing Contamination During Construction**

During the construction process it is almost impossible to prevent some contaminating materials from entering the pipe system. It is extremely important to keep this contamination to a minimum, so the system can easily be flushed and disinfected before being put back into service. All pipes should be carefully stored and handled to prevent damage and the possibility of contamination. After it is in the trench, the end of the pipe should be

securely plugged each evening before the crew leaves the site. This will prevent small animals from entering and will also be a safety measure to protect children who may play in the area.

When the construction is finished, the contractor must be certain the new portion of the distribution system is thoroughly disinfected before allowing it to be joined with the existing system. The new portion should be flushed and disinfected and a coliform test must be taken and the water shown to be of potable quality before it can again become part of the system. This process should be conducted according to AWWA Standard C651-92, covered in Chapter 6. After the disinfection process, heavily chlorinated water should be disposed of according to DEQ requirements. The water should never be discharged directly to a stream or lake, because chlorine is highly toxic to fish in small amounts.

#### **7.3.4 System Repairs**

Care must be taken when making repairs to avoid contamination if possible. The section of the distribution system to be repaired should be isolated as quickly as possible. This is especially necessary if extensive damage is occurring because of washouts or flooding. Some water system personnel leave a small positive pressure on the line to be repaired so all water will flow out of the pipe and the contaminated water will not flow back in. This generally requires sufficient pumps to keep the water out of the hole and keep it from surrounding the pipe while the repair is being made. Customers in the area which will be without water should be notified as quickly as possible and requested to not open their taps until notified by the system operator. Notification before the water is shut off is best so the customers can make sufficient preparations.

It is important to dig out the trench from under the pipe so the pipe is exposed and the repair clamp can be installed freely. This will also allow for clean replacement pieces to be installed. Some water system personnel disinfect the clamp and/or the piece of pipe to be inserted. This is especially important if these pieces of equipment have been sitting around in a storage yard, exposed to the elements.

Before the repair is made, calcium hypochlorite granules should be placed into the pipe in sufficient quantities to disinfect the portion being repaired. This should result in a chlorine concentration of 100 to 300 mg/l in the pipe. In wet excavations, large quantities of hypochlorite should be applied to open trench area to lessen the danger of contamination. The interior of all pipes and fittings used in making the repair must be swabbed or sprayed with a one percent hypochlorite solution before they are installed.

Once the repair has been completed, water should be held in the line as long as possible to give the opportunity for the chlorine to kill the bacteria. In most cases, the operator will be asked to get the system back into service as quickly as possible. The system should then be flushed and the nearby customers should be notified and asked to flush their lines.

Coliform samples should be taken on both sides of the main break after pipe repair. If positive results are found, the system should again be flushed and samples taken until no further contamination is apparent. After satisfactory coliform results are obtained the water main may be returned to service.

More information on system repairs procedures are found in *Distribution System Operation and Maintenance*—see Bibliography.

#### **7.4 Preventive Maintenance Program and Recordkeeping**

Even though much of the distribution system cannot be seen, regularly scheduled maintenance and good recordkeeping must be part of an operator's annual activities.

### **7.4.1 Recordkeeping**

The operator should keep a file with a distribution system map showing the location of all valves and valve boxes, hydrants, and pipe with pipe diameter indicated. The map and related files should include notations of repair work. Piping needing frequent repair may be due for replacement. Additional records should be kept to provide information on equipment, complaints, monitoring and maintenance. Monitoring records must be kept a minimum of ten years. Records kept should include:

- water taste and odor complaint locations
- repair and leak locations
- valve and hydrant locations and condition
- coliform sample locations and sites of unsatisfactory results
- meter totalizer readings
- amount of water used
- tank inspection dates and findings
- tank maintenance dates and details
- pump maintenance and repair dates and details
- water quality monitoring dates, locations and results
- water treatment records and chlorine residuals maintained, if applicable
- spare parts inventory
- operator and owner's manuals for all equipment.

This information is essential for tracking performance and problem areas of the water system. It is also needed to document water quality provided to customers and to indicate the need for improvement projects.

### **7.4.2 Hydrants**

A program of distribution system flushing should be established. A system flush in the spring and again in the fall will help to keep sediments and slimes loosened and washed away.

Flushing is usually done at a fire hydrant or at special flushing hydrants on dead ends (Figure 7.4.2). Larger systems must develop a flushing system whereby hydrants nearest the source are flushed first, and subsequent hydrants are flushed sequentially outward toward the end of the distribution system. This prevents suspended sediment from being inadvertently flushed back into the distribution system through interconnections and looped mains. The hydrant flushing exercise can be combined with an inspection of the hydrants.

Hydrants require an annual inspection, maintenance, and repair routine for the following items:

- pressure and flow
- loose or missing caps and cap chains
- damaged nuts or cracked barrels
- lost or damaged gaskets
- peeling or wearing paint
- leakage, using a listening device
- lubrication of threads and operating nut
- adequate clearance above ground and from poles, posts, buildings
- gate valve condition and that the valve is in the ON position
- complete barrel drainage after use



**Figure 7.4.2. Flushing hydrants**

The barrel of the hydrant must be drained after use to prevent freezing and damage. Hydrants have a drain hole and if it is plugged, it may be necessary to remove the inside assembly of the hydrant and clean it out. If the gravel drain zone has failed, it would be necessary to excavate and replace the gravel bed.

Remember that hydrants should be kept fully open or fully closed. Either way will allow any remaining water in the hydrant to drain from the drain hole and thus prevent damage from freezing. Partially closing the hydrant will not allow this drainage. Hydrants must also be opened and closed *slowly* to prevent breakage of the connecting pipe or joint.

### **7.4.3 Valves**

Valves should be inspected and operated annually. Valves are more apt to suffer from lack of use than from overuse. Annual exercise of valves will keep them in operable condition.

Valves should be exercised full open to full closed. Records should indicate whether the valve is right or left hand, whether the valve is normally closed or open, and how many complete turns are needed to fully open or fully close the valve. The condition of the packing and nut should be noted. A follow-up program of correction of valve deficiencies should be carried out and these corrections or replacements noted in the valve file and on maintenance maps.

Valve boxes are often located in streets and they should be checked annually to see that they are not damaged, filled with debris, or paved-over.

### **7.4.4 Storage Tanks**

Storage tanks should be drawn down at least once a year for a complete inspection, inside and out. Inspection should include ensuring the access hatch lock is operable and the lid is of shoe-box style to prevent contaminant entry. Inspection of the vent is also necessary to ensure the screen is in good condition and prevents rodent or reptile entry into the tank.

Many small systems contract with professional tank maintenance and repair firms to have their tanks inspected every few years. The inspection would cover interior and exterior tank coating condition. After the inspection the tank should be thoroughly disinfected using an AWWA standard procedure, before being placed back on line.

If a new interior coating is needed, an ANSI/NSF approved substance must be used. Interior paint must be properly applied and cured, so no tastes, odors or toxic materials are leached into the water. Procedures must also be implemented to maintain system pressure and service while the tank is off-line.



**Figure 7.4.4. Ground-Level Storage Tank**



## **Chapter 8: Cross-connections and Backflow Prevention**

Cross-connections and Backflow Prevention may be one of the least understood and most important topics covered in this manual. In fact, many small ground water systems are more vulnerable to backflow situations than larger systems because they do not always have the luxury of continuous positive pressure from elevated storage reservoirs or an emergency power supply.

In a smaller system, when the well pump goes down due to a power outage or mechanical failure, consumers often continue to use water and negative pressures are created throughout the system. If a cross-connection exists between the potable system and any other liquid, gas, or substance, it can be siphoned back into the potable system. This is just one example of how backflow can occur from a non-potable source to a potable source, but certainly not the only way. This chapter will explore other cross-connection scenarios typically found in small water systems, and the preventive measures and equipment which can be applied to prevent backflow.

The small system operator needs to have a basic understanding of cross-connection concepts, terminology, prevention techniques and equipment related to this subject. This chapter will provide an introduction to this complex subject; however, it is not intended to be a substitute for the fine training courses available to Montana operators.

### **8.1 Cross-connections and Backflow Defined**

A ***cross-connection*** is an actual or potential connection between a potable water system and any other liquid, gas, or other substance. There are two types of cross-connections, direct and indirect. A ***direct cross-connection*** is a physical link between the piping arrangements of a potable and non-potable system. An ***indirect cross-connection*** is where the water itself makes the connection such as a hose from a potable supply submerged in contaminated water and is subject only to back-siphonage (Figure 8.1a).



***Figure 8.1a Indirect Cross-connection***

***Backflow*** is the unwanted reverse flow of water, gases or other substances into a potable water supply distribution system. It can potentially occur any time there is a cross-connection between the potable supply and any source of pollution or contamination. Backflow occurs when conditions in the system cause ***back-siphonage*** or ***back-pressure***.

#### ***8.1.1 Back-siphonage***

Back-siphonage backflow can occur when a negative pressure (below atmospheric pressure, or a vacuum) develops in the distribution system which can then allow pollutants or contaminants to be siphoned into the water system. Figure 8.1.1a illustrates this principle.

Negative pressures can be caused by undersized pipes, pipeline breaks, or high withdrawal rates such as the use of fire hydrants.

Small systems on ‘hilly’ terrain are particularly vulnerable to negative pressures. Heavy water use at the lower elevations can literally siphon the water away from the higher elevation portion of the distribution system.



**8.1.2 Backpressure**

Backpressure backflow can occur when normal flow in the system is reversed due to an increase in the downstream pressure above that of the supply pressure. This allows contaminants to be forced back into the potable water system. Examples of situations which might cause backpressure are pumps connected to the system and thermal expansion from water heaters and boilers.

**8.2 Public Health Significance - Hazard Determination**

Cross-connections and unwanted backflow have serious health implications. Many cases have been documented tracing serious disease outbreaks directly to a specific cross-connection and backflow condition in a potable system. These cases have been particularly prevalent for underground sprinkler systems, submerged hoses, and at or near commercial facilities with high-hazard non-potable uses such as hospitals and industrial sites.

Although major disease outbreaks get plenty of publicity, it is likely many backflow events occur in small systems and go unnoticed. This is because too few people may be affected to create a public stir, or persons who become ill may just think they have the flu.

A backflow event may also be of a short duration. Monthly bacteriological testing may not catch the localized and short-term contamination event. Even if contamination is wide-spread, an event can occur and be flushed-out of the system before the next sample is collected.

An occasional unsatisfactory bacteriological test result may be an indication of cross-connection problems and should not be dismissed as sample collection error or a problem with the analytical laboratory. The conditions which caused the contamination event may already have passed before check-samples are collected.

Also significant is the possibility that a chemical contamination event may occur and not be detected with the infrequent monitoring schedules allowed for these compounds. Chemical contaminant monitoring is designed to give an indication of contaminant entry from the water source, not a sporadic event caused by a cross-connection within the distribution system.

Operators should be constantly aware of possible operational conditions which may cause cross-connection and backflow situations. Was power to the pump off? Was the pump out of service for repairs? Was there a line-break which caused an unusually high amount of water loss in one area?

From a health standpoint, the industry has assigned a *Degree of Hazard* classification to the severity of a potential cross-connection hazard.

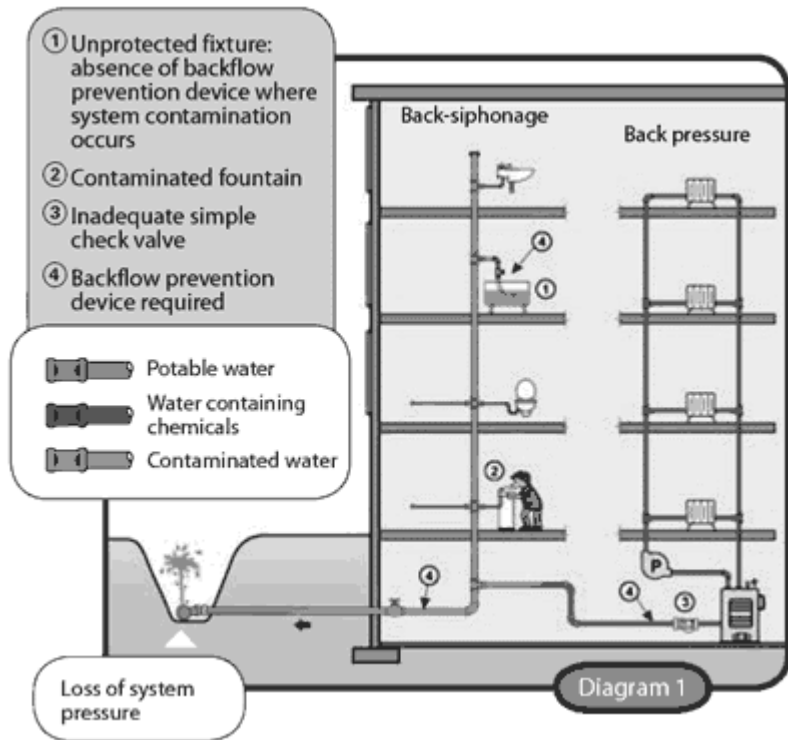

**Figure 8.1.1a Potential Back-siphonage**

## ***Chapter 8: Cross-Connections and Backflow Prevention***

---

This degree of hazard is further separated into “*Non-health Hazard - Pollution Hazard - Non-toxic*”, and “*Health Hazard – Contamination Hazard*”. Any of these words may be used to define the degree of hazard for each situation.

The backflow prevention device, assembly, or method appropriate for a particular cross-connection situation is based on the degree of hazard.

### ***8.2.1 “Non-health Hazard - Pollution Hazard”***

These conditions exist when an actual or potential threat to the potable water system is non-toxic, not a health hazard, and would only impair the water aesthetically, resulting in objectionable taste, odor or appearance.

Examples are generally related to food-grade products, some dairy equipment and connections between potable systems. However, some authorities may classify some commercial pools, fire sprinkler systems and lawn irrigation systems as pollution hazards.

### ***8.2.2 “Health Hazard – Contamination Hazard”***

Health hazard conditions exist when an actual or potential threat to the potable water system is a hazard which could result in sickness or death. Examples include car washes, hospital equipment, wastewater treatment plants, some water treatment equipment, commercial boilers, some fire sprinkler systems and some lawn irrigation systems.

## **8.3 Types of Cross-Connection Control**

Although every consumer has a responsibility to protect the potable water supply serving them, there are responsibilities for other types of cross-connection control included in the definitions of Containment and Isolation.

### ***8.3.1 Containment or Service Protection***

*Containment* means the appropriate type or method of backflow protection at the service connection. It is the responsibility of the water purveyor. The intent of this type of control is to restrict the backflow of pollutants or contaminants from the consumer facility back into the water system. An example is a requirement by a municipality that an appropriate backflow preventer be placed between a municipal water main and a hospital or industrial site. A small subdivision might require a backflow preventer on every service line to every residence.

### ***8.3.2 Isolation or Internal Protection***

*Isolation* means the appropriate type or method of backflow prevention within the consumer’s potable water system at the point of use. Typically construction of this part of the water system is governed by local plumbing codes. In the examples listed above for containment, point of use backflow preventers are used to isolate every cross-connection on the site or facility from the potable water system. For very small private systems, the owner/operator is responsible for the protection of employees and customers by providing a potable system which is protected from backflow of pollutants and/or contaminants.

## **8.4 Types of Approved Backflow Preventers**

There are five types of approved backflow preventers commonly used by the industry, and several specialty items allowed by some ordinances under certain conditions. Chapter 6 of the *Uniform Plumbing Code*, which Montana has adopted, is very specific in terms of the type of preventer that can be used under various backflow types and hazard conditions. The intent of this section is to help the operator recognize cross-connection situations, understand what backflow preventers are available and be able to recognize a backflow preventer in

use. The appropriate backflow prevention assembly or device is determined by the degree of hazard and the type of cross-connection.

**8.4.1 Air Gap**

An *air gap* is a *method* for backflow prevention that is considered the ultimate backflow preventer, although it is relatively easy to circumvent in unmonitored situations. An air gap should be used whenever possible before any other type of preventer is considered (Figure 8.4.1).

An air gap is defined as a physical separation between a potable and non-potable system by an air space. An example of an air gap used for bulk water hauling stations is provided in Chapter 7: *Distribution Systems*.



**Figure 8.4.1. Air Gap**

The best example of this is the standard design of all types of sinks where there is a separation between the free-flowing discharge of the faucet and the overflow rim of the receiving basin. Air gaps can be used in many other applications such as for swimming pool spouts, water hauling stations and stock water tank fill spouts. They can be used for both low and high hazard situations. They must be at least twice the diameter of the discharge pipe, but not less than one inch. Other rules related to fixture types and the affect of side-walls may also apply.

**8.4.2 Atmospheric Vacuum Breaker and Hose Bibb Vacuum Breaker**

An *Atmospheric Vacuum Breaker (AVB)* (Figure 8.4.2a) is a device consisting of a body, an air inlet valve, a check seat, and an air inlet port. During normal operation, potable water pushes up the air inlet valve and seals off the vent. If a negative pressure develops in the supply line the air inlet valve drops to seal the opening while the vent opens to admit air to break the vacuum.

**Atmospheric Vacuum Breaker**

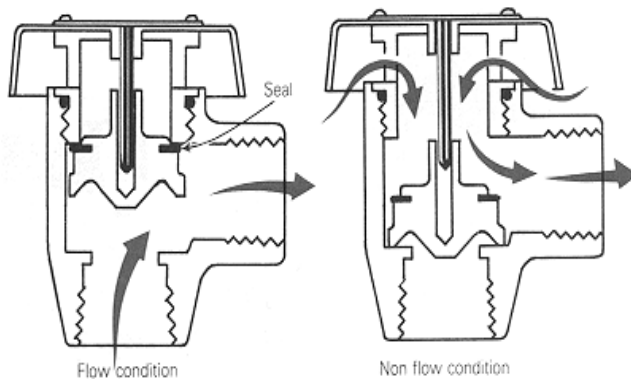

AVBs are typically used on residential and other small lawn irrigation systems, commercial dishwashers and on many types of bathroom, utility room, laboratory, commercial kitchen, and other fixtures where a hose might be connected to a faucet. AVBs may be used for low and high hazard back-siphonage applications only where there are no downstream shut-off valves.

AVBs cannot be used under continuous pressure and they cannot protect against backpressure backflow conditions. A *Hose Bibb Vacuum Breaker (HBVB)* (Figure 8.4.2b) is a type of AVB. It is one of the simplest and cheapest ways of preventing low and high hazard back siphonage through hoses attached to threaded connections.

**Figure 8.4.2a. Atmospheric Vacuum Breaker**

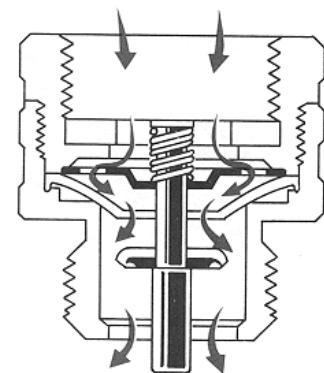

HBVBs are a device with a metal body, a spring-loaded check valve, and air inlets. They can and should be installed on all threaded hose connections, sill cocks, and yard hydrants where there is any possibility a hose will be attached for any purpose. HBVBs are available with a means to manually drain the device for freezing conditions.

**8.4.3 Pressure Vacuum Breaker Assembly**

A *Pressure Vacuum Breaker Assembly (PVB)* is an assembly consisting of an internally loaded air inlet valve, an internally loaded check valve, two properly located test cocks, and two isolation valves. PVBs are suitable for low and high hazard back-siphonage installations the same as AVBs but PVBs may have valves downstream and be under continuous pressure. However, PVBs are not appropriate where back-pressure backflow may occur. (Figure 8.4.3)

Typical installations include swimming pools, heat exchangers, degreasers and livestock water systems. They are most often used in sprinkler irrigation systems with downstream control valves.

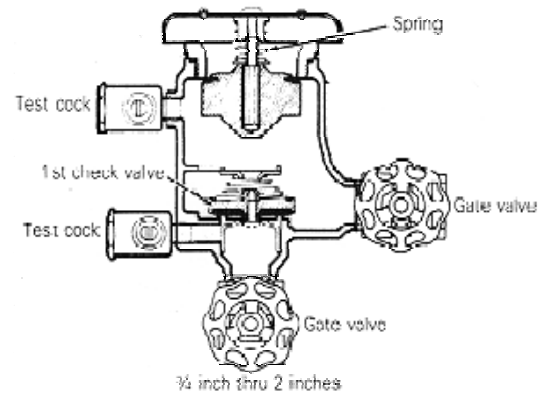

**Figure 8.4.3. Pressure Vacuum**

**8.4.4 Double Check Valve Assembly**

A *Double Check Valve Assembly (DC)* is an assembly consisting of two independently acting internally loaded check valves, four properly located test cocks, and two isolation valves.



**Figure 8.4.4. Double Check Valve**

Use of DCs is restricted to low hazard back-siphonage and backpressure. Since there is not always agreement as to the definition of low hazard, use of DCs is generally limited to cross-connections which would constitute a nuisance or be aesthetically objectionable such as foods, steam, and air. (Figure 8.4.4)

**8.4.5 Reduced Pressure Principle Assembly**

A *Reduced Pressure Principle Assembly (RP)* is an assembly consisting of two independently acting internally loaded check valves, a differential pressure relief valve, four properly located test cocks, and two isolation valves. RPs are the only backflow preventers recognized for use for both low and high hazard applications under both back-siphonage and backpressure conditions. (Figure 8.4.5)

They are often used for containment to protect a municipal system from an industrial or commercial connection such as a hospital, mortuary or car wash. However, they are also frequently used for isolation from a potential contaminant within a private system. As smaller size RPs become available, they are frequently being used for point of use protection for boilers, air conditioners, chemical feeds, carbonators, and lawn sprinkler systems.

**8.4.6 Specialty Valves**

There are a number of “specialty valves” not approved as backflow preventers, but may be allowed for specific applications. Manufacturer



**Figure 8.4.5. Reduced Pressure Principle Assembly**

catalogs often list these valves as backflow preventers.

Many small system operators make the mistake of assuming a single check valve is an appropriate backflow preventer, but this is not the case. However, a “Dual Check Valve Device” may be allowed as a containment backflow preventer for residential applications. These devices may also be appropriate for limited use for isolation within a private water system. Other “specialty valves” are available for limited isolation applications, but all must be approved prior to installation.

#### ***8.4.7 Methods, Devices, Assemblies Defined***

Note the five backflow preventer types are further designated as a Method, Device, or Assembly with specific criteria applicable to each. The Air Gap qualifies as a method. The Hose Bibb Vacuum Breaker and the Atmospheric Vacuum Breaker are both devices, and the other three preventers (Pressure Vacuum Breaker, Double Check Valve and Reduced Pressure Principal Valve) are assemblies. A device is defined as being self-contained with no shut-off valves and no test cocks. An assembly must have test cocks and shut-off valves, and must be capable of being tested and repaired in line.

### **8.5 General Installation Requirements**

There are several installation requirements which apply to backflow preventers. The most important is that no direct connection can be made to any sewer line or sewer system. If a discharge has to go to a sewer, it must have an appropriate air gap.

Access and clearance must be provided to properly test and repair all backflow preventers. This usually means a clearance of at least 12 inches in all directions. If the preventer is more than 5 feet above floor level, a permanent platform must be constructed that will support the weight of an individual and test equipment.

If a by-pass line is installed around a backflow preventer, it must be equipped with the same level of protection as the main line. In general, backflow preventers should not be down sized from the existing pipe line.

Backflow assemblies and devices used in cold climates such as Montana must be protected from freezing conditions.

Do not tamper with, change, or modify the design or characteristics of any backflow preventer. This includes fixtures and appliances manufactured with integral preventers or air gaps. Repairs must be made by a trained technician using approved manufacturer’s parts only.

### **8.6 Thermal Expansion**

When water is heated it expands in volume. Water in a residential water heater may expand about one-half gallon during each recovery period. In an open system this water will be easily absorbed. However, if a backflow preventer is placed in the service line to a residence it will make a closed system with no room for expansion. Since water is not compressible, it has to go someplace and that is generally out the water heater pressure relief valve. This is a dangerous situation since these relief valves are not designed for frequent operation. In addition, the pressures generated may cause an explosion or release carbon monoxide.

Operators need to recognize the implication of placing a backflow preventer or a check valve upstream of a water heater. If this must be done, installation of a small thermal expansion tank between the water heater and backflow preventer is the simple solution.

### **8.7 Inspection & Testing**

## **Chapter 8: Cross-Connections and Backflow Prevention**

All backflow prevention assemblies must be tested by a certified backflow assembly tester at the time of installation, repair, or relocation, and at least on an annual schedule thereafter.

Many assemblies in water systems have been in place for 25 years or more and have never been tested. It is likely many of these have failed long ago, and currently provide little or no protection of the potable water system.

Contact the Public Water Supply Section of DEQ for information on how to locate a certified tester.

### **8.8 Typical Small System Cross-connections**

Following is a partial list of cross-connections encountered in small ground water systems.

- *Swimming Pool & Spa Fill Lines* - All sorts of unprotected hoses and piping arrangements are used for this purpose. If they are submerged, the pool becomes a reservoir which will siphon back into the potable system if there is a loss of system pressure.
- *Utility Service Sinks* - Commonly a hose is attached to these sinks to fill mop buckets, wash containers, etc. Again, a submerged hose will siphon if there is a loss of system pressure and the sink faucet is not properly protected with a HBVB or AVB.
- *Restaurant & Commercial Kitchen Sinks* - Same problem as with service sinks.
- *Stockwater Tank Fill Lines* - Submerged inlets are often used to keep them from freezing, and almost never are these protected.
- *Sprinkler Irrigation Systems* - No protection, the wrong backflow preventer, or improper installation of a backflow preventer are common observations.
- *Hose Bibbs & Hose Attachments* - The garden hose is a universal culprit. Commonly they have no HBVB and are submerged in a barrel, or duck pond, or mud puddle.
- *Water & Wastewater Treatment Facilities* - Aside from unprotected hoses, operators of these facilities need to be particularly aware that all potable supply lines to chemical feed tanks need to be protected.
- *Recreation Vehicle Water Fill & Wastewater Washdown Facilities* - Often are fitted with just hoses and no protection.
- *Water Tanker Fill Stations* - Some of these are used for both potable and pesticide tankers. They need an air gap to prevent the hose from ever entering any tank.
- *The Frost-proof Self-draining Yard Hydrant Installed into the Well through the Well Seal* - In this cross-connection any time the hydrant is used with a hose submerged in any liquid, and the hydrant is then closed, the liquid will be siphoned directly into the well as the yard hydrant drains. The only approved solution for these installations is to remove the yard hydrant, replace the interior fitting of the pitless adaptor, and install a new full cover gasketed and vented well cap.

### **8.9 Managing and Reporting Backflow Events**

If it becomes apparent, either by observation or testing, a backflow event has occurred, the operator has a responsibility to notify consumers and to report the event to DEQ. Public notification could involve door-to-door or telephone notification, and in extreme cases, may require immediate system draining and flushing. Urgency of the notification will be determined by the degree of health risk created by the contamination event. DEQ can provide assistance to evaluate the health hazard, locate the problem, and help restore the system to working condition.

### **8.10 Cross-connection Control Plans**

In 1997, DEQ, with the help of a task force, developed a cross-connection rule ARM 17.38 Subchapter 3, which requires all public water systems to eliminate cross-connections if possible and if not possible, protect them with the appropriate backflow prevention valve. This Subchapter also contains language which allows public water

## ***Chapter 8: Cross-Connections and Backflow Prevention***

---

supply systems to voluntarily establish and implement a Cross-connection Control Program. The rule requires the following elements to be included in each plan:

- Operating rules or ordinances to implement the program (DEQ can provide sample ordinances upon request).
- Language defining responsibility of both the utility and the consumer.
- Provisions to conduct surveys of consumer premises.
- Written policies, procedures, and criteria for assessing the degree of hazard.
- Provisions for requiring installation of backflow preventers where cross-connections, which cannot otherwise be practically eliminated, are identified.
- Provision for a trained person to conduct surveys.
- Provision for maintenance of records and maps that show locations and to record the inspection and testing history of backflow preventers.
- A policy and procedure established to have a certified person inspect and test backflow assemblies.

An optional element to include in the Cross-connection Control Plan is a consumer education and information program to prompt consumers, particularly industrial users, to help identify, eliminate, and control cross-connections. Although very small non-community public supplies may not need a written plan, owners and/or operators still need to be able to recognize and eliminate cross-connections within their own systems.

## **Chapter 9: Safety for Small System Operators**

The water and wastewater industry is one of the most dangerous professions in which to be employed. The combination of excavation, construction, chemical use, electrical components and confined space issues create several potentially hazardous situations for a public water supply system operator. Couple these inherent risks with the small system scenario in which an operator is often working alone, and a strong argument is made for establishing a safety program at every public water supply system.

This chapter will provide an overview of the hazards affecting a public water supply system operator in each of the key safety areas. While most hazards faced by a small system operator are addressed, this chapter is not a comprehensive manual for operators whose jobs include excavation, trenching or electrical system work. Individuals with these responsibilities must refer to more comprehensive safety manuals specific to their particular duties. Ongoing training on system safety and development of a system-specific safety program are strongly recommended.

Chapter 6 of *Small Water System Operation and Maintenance* and Chapter 7 of *Distribution System Operation and Maintenance* provide additional detail for initiating and implementing a system-wide safety plan—see Bibliography.

### **9.1 Elements of a Safety Program**

A successful safety program relies on the participation of everyone involved in the public water supply system - from management to operations and laborer staff. The purpose of a safety program is to *prevent* accidents. Three critical aspects of a safety program are:

1. Identifying unsafe conditions and resolving those conditions,
2. Making personnel aware of unsafe acts, and
3. Holding or attending regular safety training programs.

The vast majority of injuries on water systems jobs are caused by unsafe acts of the person injured. Often, injuries occur when improper or dangerous procedures continue to be used because unsafe conditions went uncorrected.

Unsafe conditions can become commonplace in small systems when an operator works alone and does not have coworkers to point-out safety concerns. They may also occur if one individual attempts an activity for which more than one person is needed - even if the second person would serve largely as an observer able to summon help if needed.

Unsafe conditions commonly encountered in public water supply systems include:

- Electrical Hazards
- Water Treatment Chemical Hazards
- Chemical Storage and Handling Hazards
- Flammable Situations
- Chlorine Toxicity and Handling
- Traffic Control in Work Areas
- Shoring and Trenching Hazards
- Confined Spaces
- Hearing and Vision Hazards
- Mechanical Hazards





Accidental death and injuries have occurred in public water supply systems in Montana. Close-calls are also reported with alarming frequency. No matter how elaborate the safety program or how highly developed the safety equipment, it is up to each individual to follow and enforce safety requirements for their system.

## **9.2 Electrical Safety**

Most equipment used in water supply and treatment is electrical and often piping is used to ground electrical systems. Water is a good conductor of electricity. The combination of these characteristics requires every operator be careful when working with or troubleshooting these systems. In this manual, Section 5.6.4 *Electrical Safety*, provides a discussion of the electrical safety issues and precautions which are applicable to pump houses and well controls for small water systems.

The bottom line for electrical safety is that only individuals knowledgeable in electrical systems and safety should be working on electrical equipment. Operators who do not work on electrical equipment must be able to recognize the dangers of exposed wires, pooled water near wiring and controls, and corroded wiring. If these items are observed they must be remedied immediately, before an accident or injury occurs.

## **9.3 Chemical Safety**

Chemicals used in water treatment may be flammable, corrosive or toxic. “Right -to-Know” laws require employers to inform employees of the possible health effects resulting from contact with hazardous substances. *Material Safety Data Sheets* (MSDS) are provided with all hazardous chemicals purchased and must be made available to all individuals potentially exposed to the chemicals through handling or routine operations. These sheets describe specific materials compatibility, handling precautions, spill responses and hazardous properties of the chemical. The MSDS sheets must be posted in a conspicuous location for easy reference.

Flammable or explosive chemicals are encountered in laboratories or as fuel. Gasoline, acetone, propane and hydrogen gas are examples of flammable chemicals. Explosive or flammable conditions may be encountered in confined or enclosed spaces and monitoring equipment is essential to protect an operator from these hazardous conditions. Flammable gasses include hydrogen sulfide, carbon monoxide and methane, among others. Many of these are odorless and colorless and cannot be detected without specialized devices. If the proper detection equipment is not available, an operator must postpone the work until equipment can be obtained. They should refuse to do anything which would endanger their lives.

Corrosive chemicals may weaken, burn and/or destroy a person’s skin or eyes. Examples of commonly encountered corrosive chemicals include: Calcium Hypochlorite, Chlorine, Sodium Chlorite, Sodium Hydroxide, Sodium Hypochlorite and Zinc Orthophosphate. Safety procedures for protective equipment (see Section 9.12) and chemical handling precautions, especially for eye and skin protection, must be followed whenever these chemicals are used. Since many of these chemicals are acidic the old school-day rhyme, “*add acid to water - like you otta*” is a good way to remember the proper way to mix these chemicals to avoid acid splashes.

If corrosive chemicals come in contact with clothing, the clothing must be immediately removed and the skin rinsed thoroughly with water. Rinsing spilled areas on clothing while still wearing the clothing may result in a larger burned area of skin.

Other chemicals of concern include mercury, cadmium, and other heavy metals; organic solvents; and gases such as chlorine and ammonia. These lists are not all-inclusive. Other chemicals are encountered in public water supply system operations. Chemicals may cause injury when ingested or inhaled so personal safety equipment includes both protective clothing and sometimes breathing apparatus. If a chemical is spilled, contact the Montana Disaster and Emergency Services Hotline at (406) 444-6911 to report the spill and obtain assistance with proper clean-up and disposal.

## **9.4 Chemical Storage and Handling**

The two important aspects of chemical storage are compatibility and containment.

*Compatibility* refers to appropriate storage tank, piping and valve materials which are intended to be used with the particular chemical. Materials not compatible may corrode over time and become non-functional or fail.

*Containment* refers to the need for protective berms or other means by which chemical spills can be contained for easier clean-up. Containment is required for chemical storage of over 500 gallons of hazardous solutions. Containment is also a good idea when the available work area around the chemical is limited and even minor spills would affect normal access to essential equipment.

Chemical handling hazards are detailed in the Material Safety Data Sheets (MSDS) for each chemical. However, handling hazards are not limited to the corrosivity or toxicity of a chemical. Most injuries are caused by lifting, straining or sprains resulting from improper movement of bulk chemicals and equipment. So, in addition to using appropriate personal protective gear, an operator must obtain and use the proper equipment which allows safe handling and lifting of heavy objects.

## **9.5 Storage of Flammable Chemicals**

Chemicals which are flammable require special storage conditions. Liquid chemicals must be carried in safety cans. Flammable liquids and solids, such as calcium hypochlorite (which is flammable if in contact with hydrocarbons, i.e., oil, paint and grease), must be stored in a separate facility. This is to ensure the chemicals are not accidentally exposed to flammable conditions. An example is the spontaneous combustion caused if linseed oil-soaked rags are dropped in a garbage can also containing grease rags.

To avoid hazards caused by chemical spills, all spills must be cleaned up immediately and the facility must be kept clean to allow immediate recognition of unsafe conditions. Spills left unattended may be forgotten, or a person unfamiliar with the chemical spilled may attempt an improper clean-up.

## **9.6 Chlorine Safety**

Safety issues of chlorination equipment are relatively simple if hypochlorinators are used. This is one reason for their popularity with small systems because personal protective clothing and eye protection is usually adequate. If gas chlorination equipment is used, safety issues encompass personal protection clothing, self contained breathing apparatus, gas chlorine tank repair kits and emergency procedures involving the public if leaks are significant. Operators of systems using gas chlorination should be familiar with emergency repair equipment and know how to use it properly.

Additional information on gas chlorination safety is found in *Water Distribution System Operation and Maintenance—see Bibliography*.



Chlorine gas leak detection and safety around all kinds of chlorine is presented in Chapter 6: *Treatment of Ground Water*. Personal protection gear required around these chemicals is described later in this chapter. If a public water supply system is operating a gas chlorination system, the scope of the safety program is beyond this manual and additional information must be obtained.

## **9.7 Traffic Control**



**Figure 9.7. Traffic signing**

Safe traffic control procedures are essential, even for small systems. Hazards to workers caused by fast and uncontrolled traffic endanger workers and drivers of other vehicles. Traffic control includes advising motorists and pedestrians of conditions affecting road use around the work site. Advance warning to motorists, signing and traffic guidance are all necessary components of a safety program for projects in streets.

All work performed in streets and highways must be done in accordance with local, city and state regulations. If the project will take place on one of these roadways, contact each of the local affected agencies to obtain information about proper procedures.

Accidents involving workers installing, operating or repairing valves are also common. Appropriate warning, signing and traffic guidance to motorists is important in these situations, even if the work is not expected to take a very long time. Orange jackets on workers are necessary to help identify them to motorists. When concentrating on the work at hand, an operator is less likely to notice or react to oncoming traffic.

## **9.8 Shoring and Trenching**

This manual is intended to be a basic groundwater manual for operators of very small public water supply systems. Because every small system is different, an operator of one of these small systems may only have limited exposure or may have full participation in trenching and excavation projects. A basic knowledge of excavation and trenching safety is important for all operators so reasons to limit involvement in these projects without additional training are understood.

Excavations and trenches present several areas of safety concerns. Encountering other utilities (such as buried gas or power lines) during an excavation is always a concern—they must be located prior to performing any work. Cave-ins and wall collapse are safety concerns even if the trench is relatively shallow. When a worker is bent over to service a pipe or valve, their effective height is greatly reduced and they can be buried with a relatively small amount of material. Suffocation caused by the immense pressure the soil materials have on the chest is often the cause of death in trenching accidents, even if the victim is not buried over their head. If a victim is completely buried, rapid removal of the collapsed materials is sometimes prevented by concern over causing damage to the trapped individual with shovels or other equipment.

Cave-ins and other accidents at excavation and trenching sites occur too frequently in Montana. Collapse of trench walls can be caused by vibrations from traffic or equipment next to the site, recent rains, soil conditions and the weight of improperly located spoils piles.

Shoring, shields and trench sloping are all methods used to protect workers in trenching and excavation projects. Shoring the trench walls with specialized barriers is used to support the sides of an excavation to prevent wall collapse. A shield is a structure within which work is performed. They are strong enough to protect workers and equipment in the event a collapse occurs. Sloping the sides of the excavation to incline away from the excavation adds to trench safety. The angle of incline needed is determined by the soil conditions of the trench. Placement of a sufficient number of escape ladders at regular intervals within the trench or excavation is critical to enable workers to get out of the trench when necessary.

Specialized “Competent Person Training for Excavations” in soil assessment, trenching and shoring requirements is essential to anyone involved in this type of work. Federal Occupational Safety and Health Administration (OSHA) regulations require that each employer must provide a place of employment which is free from recognized hazards which are causing or are likely to cause death or serious physical harm to employees. The federal regulations also require employees comply with occupational safety and health standards and rules applicable to their own actions. The Montana Department of Labor and Industry should be contacted for more information about OSHA requirements for construction and main repair sites.

## **9.9 Confined Spaces**

A confined space, as per OSHA, is one in which ventilation may be insufficient to remove dangerous gases or add fresh air. In addition, the size of the confined space opening may make it difficult to remove a suddenly disabled person.

Dangerous gases which may accumulate in confined spaces, depending on conditions, include gasoline vapors, carbon monoxide, methane, hydrogen sulfide, carbon dioxide and chlorine. This is not a complete list. Many of these gases are colorless and odorless so an operator cannot know they are present without specialized testing equipment. This equipment sounds an alarm and/or produces a flashing light when unsafe atmospheres are encountered. Accumulation of oxygen deficient atmospheres (where the level of oxygen is below that needed for survival) or toxic gases may occur sporadically and therefore cannot be predicted based on past experience. If an unprotected entry and exit was made into a confined space previously without mishap there is no guarantee dangerous conditions would be avoided during the next entry.

Many small systems may be hesitant to invest in the personal protective gear, detection devices, ventilation equipment and extraction equipment necessary to safely work in confined spaces. Work must *not* be done in a confined space without this equipment and someone trained to run it. In many situations, a second person is needed to monitor the work of the individual in the confined space so rescue can occur if problems develop. Some small systems have agreements with larger systems to provide the equipment and trained personnel on an as-needed basis. It is worth it for small systems to pursue this type of arrangement if budgets and staff numbers prevent handling these events in-house.

Water system situations which may be considered confined spaces include well pits, valve vaults, manholes, and covered water storage tanks. The following is a description of safety procedures to follow when preparing to enter any tank for any reason (from *Small Water System Operation and Maintenance*, Chapter 6):

- Test the atmosphere in the tank for toxic and explosive gases and for adequate oxygen. Contact the local safety equipment supplier for the proper types of atmospheric testing devices. These devices should have alarms which are activated whenever an unsafe atmosphere is encountered;
- Provide adequate ventilation, especially when painting. A self-contained positive-pressure breathing apparatus may be necessary when painting;
- All persons entering a tank must wear a safety harness; and,
- One person must be at the tank entrance and observing the actions of all people in the tank. An additional person must be readily available to help the person at the tank entrance with any rescue operation.

## **9.10 Fire Safety**

Fire extinguishers must be available in all locations where fire hazards exist—either through chemical combustion or electrical problems. The type of fire extinguisher must be chosen by the class of fire potentially encountered. The four classes of fires are as follows:

Class A Fires: for wood paper, textiles and similar materials. Use foam, water, carbon dioxide gas or almost any kind of extinguisher.

Class B Fires: For grease, oil, paint and related materials. Use foam, dry chemical or vaporizing liquid extinguishers.

Class C Fires: Electrical equipment and in areas where live electricity is present. Use carbon dioxide, dry chemical or vaporizing liquid extinguishers only.

Class D Fires: Fires involving sodium, zinc, magnesium and other elements. These fires should be smothered with fine dry soda ash, sand or graphite.

Take the time to become familiar with the type and operation of the fire extinguishers used by the system. Make sure they are located in a readily accessible and visible location.



### **9.11 First Aid**

First aid needs for small public water supply systems may include tending to cuts, abrasions, chemical burns, inhalation of toxic chemicals, splinters, sprains, strains and broken bones.

An American Red Cross-approved first aid kit must be available in any water testing laboratory and near any work centers where cuts, abrasions or sprains might occur. Eyewash equipment is necessary near chemical handling facilities—either plumbed into the system or as stand-alone squeeze bottles. These units must be kept clean and in good operating condition.

Having training in first aid and cardio-pulmonary respiration (CPR) makes an operator more prepared to face or assist in any medical emergency situation.

### **9.12 Personal Hygiene and Protective Clothing**

Whenever an operator is working with dry or liquid chemicals they must wear adequate protective clothing. They must also be sure chemicals are not “taken home” by wearing the protective clothing when not necessary or by failing to thoroughly wash hands and any exposed skin immediately after the chemical handling is completed.

Protective equipment which may be required for general work on water systems include:

- hard-toe shoes,
- safety goggles for work around chemicals or moving parts,
- ear plugs in pump stations,
- gloves, and
- hard hats.



When using chemicals, safety goggles, a face shield, a respirator and/or mask, suitable gloves (depending on the chemical or equipment used), and an apron may be necessary. MSDS sheets will provide information on the hazards associated with each chemical and precautions that must be taken when handling the chemical.

### **9.13 Lifting**

Nearly one-third of all injuries are caused by improper lifting and handling of heavy objects. Incorrectly lifting an object can cause painful and sometimes permanent damage to a body. Seven steps to safe lifting are provided below:

1. Keep feet parted - one along the side of and one behind the object;
2. Keep back straight - nearly vertical;
3. Tip your head upward to straighten your back;
4. Grip the object with the whole hand;
5. Tuck elbows and arms in;
6. Keep body weight directly over feet; and
7. Lift slowly.

Evaluate the weight of any object and do not lift more than can be safely carried. Hand trucks, dollies or other equipment must be used when items are too heavy to carry alone and help is not readily available.

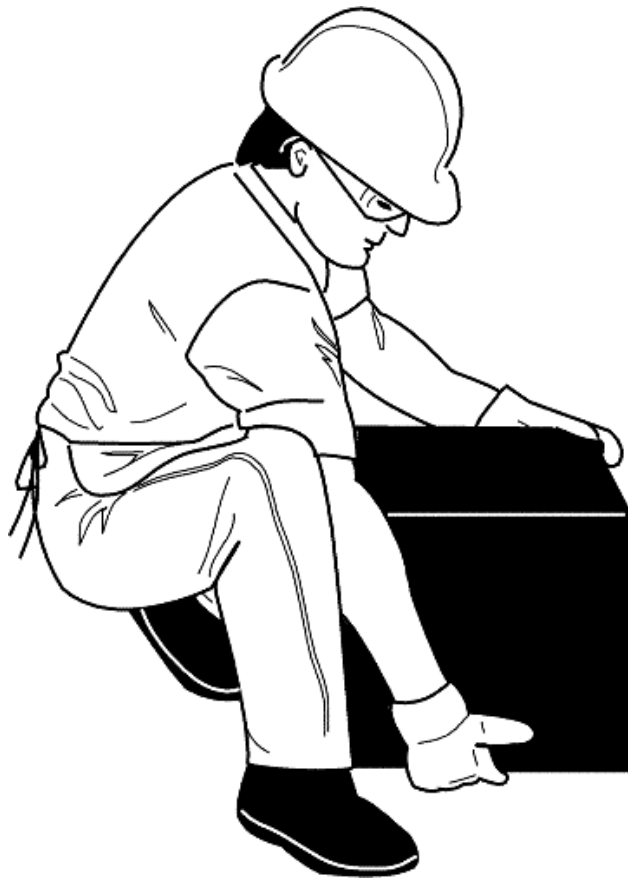



## **Chapter 10: Emergency Response Planning**

Every public water supply system, whether in a remote area or within a metropolitan development, must be secured against intentional vandalism or accidental contamination and each should have an emergency response plan. Systems serving populations greater than 3300 must have and certify to the EPA that a Vulnerability Assessment and Emergency Response Plan have been completed. Think for a moment about how customers would react if there was no water in the house for 24 hours—or for several days! How would users shower, dispose of waste, or cook? An emergency response plan is needed for a number of reasons, but mainly so that when an emergency strikes, it can be handled quickly, efficiently, and professionally; avoiding lawsuits, minimizing damage to the water system and private property, and above all, to assist in protecting public health.

Planning for an emergency is crucial because water systems are critical infrastructures for their communities. It is never a wasted effort. Remember the flood of 1997 in Grand Forks, North Dakota or the Cedar River flood in Iowa of 2008? The 2005 hurricane season with Katrina and Rita rendered hundreds of public water systems non-functioning. Many were placed on a boil order for weeks to months. Washington State in late 2007 experienced a weather situation that caused extensive wind and flood damage to about 21 public water systems. Think how vulnerable small water systems are to any number of emergency scenarios, both natural and man-made. Now is the time to plan for an emergency — whether it is caused by a natural disaster such as an earthquake, flood, tornado, or wild fire, or as the result of criminal activity, a break in the main feed line to the distribution system, or pump failure in the well.

The best person to develop an emergency response plan for a water system is the operator because that individual probably knows the system better than any other person. However, emergency response plans should not be written by only one individual or entity. There are plenty of resources to draw upon and a successful plan will cross the lines of several different departments, including security, law enforcement, management, utility, suppliers and emergency response agencies. This chapter describes the process of putting a plan together. The information presented here is very brief. More comprehensive guidelines and assistance tools can be obtained by contacting MTDEQ PWS, Midwest Assistance, Montana Rural Water, and EPA.

Any emergency response plan should be written down and stored in a binder so it can be changed as new information becomes available. More than one person should be familiar with the plan and know where to find the written document when disaster strikes. A brief emergency response plan can be developed by simply using each of the major topics listed in this chapter and answering some of the questions posed below. Preparing good maps and developing a list of phone numbers is the most critical and should be addressed first. Once the basics have been assembled, then more information and coordination with other agencies can be added as time permits. Taking some time to investigate and assemble this information now can make the handling of an emergency much more successful.

Once a plan is developed, it is critical that it be shared, practiced and that personnel are cross-trained in several aspects of the plan to be able to respond if a critical participant is unavailable when an emergency occurs. Practice the plans through table top and full scale exercises. Ask your county emergency coordinator how to get involved in your Local Emergency Planning Committees (LEPC) and participate in other planned exercises which help build partnerships and networking.

### **10.1 Identification of Possible Disruption Threats and Vulnerabilities**

What kinds of emergencies could happen that would disrupt or stop the flow of water in a public water supply system or would make the water unsafe to drink? Thinking about this question can make it easier to identify a given system's vulnerabilities. Completing a chart similar to Figure 10.1 "Potential Effects of Emergencies on a Water System" can also be helpful. There are certainly many more situations and effects to consider than are listed in this example. Section 11.9 elaborates more on emergency contact agencies and phone numbers which are helpful to have as a handy reference. It is also a good idea to have emergency contact information (contact



## ***Chapter 10: Emergency Response Planning***

names and numbers) for some of your most critical customers including hospitals, medical centers, large industries, military facilities, schools and large daycare centers.

### **EXAMPLE**

<b>Potential Effects of Emergencies on a Water System</b>						
<b>Emergency Incident</b>	<b>Well Contaminated</b>	<b>Well out of Service</b>	<b>Storage Tank Damage</b>	<b>Broken Mains</b>	<b>System Contamination</b>	<b>Power Outages</b>
Vandalism/Criminal activity	X	X	X		X	X
Earthquake	X	X	X	X	X	X
Flood	X	X			X	X
Chemical Spill/ Gas Release	X	X			X	X
Storm Event		X	X	X	X	X
Fire		X	X		X	X
Extreme Temperatures		X	X	X	X	X
Power Outage		X			X	X
Pandemic Flu		X			X	

A well pump could go out during a lightning storm or at any time due to old age. A main distribution line could break during an earthquake or a long cold snap, or due to weakening from excessive corrosion. Vandals could contaminate a storage tank with soap, dead animals or fecal material. Flood waters could immerse a well and contaminate the water source. The entire electrical control system could be knocked out by a surge of electricity or an ice storm. A truck could spill petroleum or a pesticide near one of the wells. A delivery delay may cause a system to run out of chlorine or other needed water treatment chemicals or equipment. A connection could break as a new chlorine tank is being installed, resulting in chlorine gas escaping to the surrounding neighborhood. Pandemic health illness can significantly effect the ability for the water system to be operated correctly such as if the system has only one operator and he becomes too ill to manage the system as it should be in order to keep the community needs met.

These kinds of situations happen to water systems every year. Each of them should be considered in an Emergency Response Plan to protect the public and return service to normal as soon as possible.

## **10.2 Source Protection**

### ***10.2.1 Radius of Protection***

Minimum design standards for water wells require that a minimum 100-foot radius of protection is provided around each wellhead. This protective radius must be controlled by the water system through ownership, easement or landowner agreement. The purpose of the protective radius is to minimize the amount of activity and contamination potential that can occur at the wellhead, and should be a component of any wellhead protection plan, but it is *not* intended to serve as the equivalent of a wellhead protection plan.

If the wellhead is located in an area frequented by livestock, it must be fenced to prevent their access to the wellhead. Livestock access can result in damage to caps, vents and electrical conduit. It also allows waste material from the animals to contaminate the area and increases the risk for source contamination by waste material.



***Figure 10.2.1 – Fencing Protection Around a Well***

Fencing or another type of barrier is also required if the wellhead is located in an area of vehicle traffic—such as in or near parking areas or roadways. Accidental collision of a vehicle with an unprotected well casing or controls could cause tremendous damage and result in subsequent well abandonment or loss of service. More information on source water protection is included in Chapter 4.

### ***10.2.2 Wellhead Security***

All pump houses and well house access points, including all windows and doors, must be locked to prevent unauthorized entry. Locking or securely bolted well caps must also be provided on all exposed wellheads. Frequently, bolts holding well caps in place become corroded and difficult to operate or are missing altogether. These must be replaced to adequately secure the well cap to the casing. If the cap from a wellhead can be removed without using tools, there is potential for well tampering to occur.

Screens on well vents must also be inspected regularly to be sure they are preventing entry of insects and other small debris and that a vandal would not be able to insert any material into the vent hole. Since vents allow air movement into and out of the well casing during drawdown and recovery, any substance placed in or near the vent could potentially be sucked into the well when the pumps are operating.

Barriers such as enclosures, boulders, walls, solid fencing, etc., limit the accessibility and visibility of a facility or location and can assist in the “out of sight, out of mind” theory against criminal activity. Signs that warn against unauthorized access or tampering are also a good idea because tampering with a public water system is a federal offense per US CODE Title 42, Section 300i-1. Each situation and facility will be different and should be addressed as necessary. The Water Infrastructure Security Enhancement (WISE) documents are helpful in developing the proper security measures for the system and DEQ PWS can assist in helping you access those guidance documents.

### **10.3 Security of Storage Facilities**

A contamination incident at a Montana public water supply system occurred when a ground level storage tank was vandalized. The access hatch on top of the reservoir was opened and the reservoir was used as an outhouse. The source of the contamination was discovered when the operator was investigating the cause of fecal coliform contamination detected in routine water samples. The system had just completed an extensive improvement project so the storage tank and most of the distribution system were known to be in good condition.

This example illustrates two factors to consider in securing storage reservoirs. The first is that access to the reservoirs should be controlled through fencing (Figure 10.3) or by an access ladder which can either be locked or removed to prevent unauthorized admittance. The second factor to consider is the actual access into the storage tank. The tank hatch should be a shoe-box style sealing lid and all access portholes including vents should be locked. Pressure tanks or other small storage reservoirs should be equally secured, whether they are located outside or in a building.



Vents, overflow piping and emergency drain lines must be routinely inspected to ensure they are in good condition, operating properly, and have no evidence of tampering. Flap valves or screens on the ends of overflow lines are commonly used to prevent such unwanted access of birds, insects, or rodents but may be difficult to secure. Seek out new secure designs or equipment if necessary.

### **10.4 Security of System Controls**

Exposed electrical control panels are sometimes seen adjacent to wellheads and pumping facilities. The attraction these panels have for vandals and the curious is considerable.

While locking panels are somewhat protective against direct tampering, housing these panels in a locked structure provides greater protection and access control.

Systems that utilize SCADA controls need to be aware of the operational concerns and cyber security issues if they are connected to the internet or if others have unauthorized access. Proper precautions such as firewalls, passwords, and even locked doors should be in place to protect access to these electronic and cyber system components. Visit with your system's information technology folks to make sure these things are in place and compatible.

### **10.5 Designation of an Emergency Coordinator**

Since emergencies tend to be a time of chaos, it is best if the person to be designated "in charge" is decided ahead of time. This could be the operator, the public works director, the mayor, a representative of the county emergency services office, or an outside expert.

Disaster response training should be provided for all personnel who may be involved in an incident or event. Such training should include the FEMA National Incident Management System, the Incident Command System, and other safety/response courses that will assist and protect water system staff. These courses will also help identify and develop the assignment of duties and alternates which need to be in the emergency response plans. Reviewing the emergency response plan with others in periodic training sessions is important. If the disaster affects more than the water system, the public water system coordinator may be working closely with several other coordinators in the command center or emergency operation center who are handling various jobs of repair and cleanup within the community. The local or state emergency services will be assisting with the coordination and recovery of the community's critical infrastructure.

### **10.6 Equipment and Material Resources**

Make a list of the equipment and materials that might be needed in any of the emergencies identified in section 10.1. Then list where they can be found and who to contact. Could any of the listed items be borrowed from

other departments in the community, a nearby community or water system, or is there a local contractor with the necessary equipment? Are memorandums of understanding in place with suppliers or service providers? Is there an agreement with other utilities (gas or electric) to assist in time of emergency? How can staff and other needed personnel be contacted and, in situations of widespread emergency, will their families be taken care of? Are there equipment or materials or spare parts that should be kept on hand? Who may have the correctly sized generator for your system to keep minimal operations going?

It is especially important for small water systems with limited personnel and equipment to prepare a list of available extra help and how to contact them. These may include, but are not limited to, fire departments, construction and excavation contractors, plumbers, electricians, rental agencies, and neighboring utilities with available material and personnel. Montana has recently, along with most of the country, organized and is facilitating a Water and Wastewater Agency Response Network – MT WARN. WARN is a volunteer mutual aid assistance program that is specialized for water utilities to help other water utilities in their time of need. Please visit [www.mtwarn.org](http://www.mtwarn.org) for more information and water system emergency response resources in Montana.

Remember in creating your resource list to include labs, fuel suppliers, and equipment and tire repair shops. Also consider the needs of the repair crew if the emergency conditions require long hours. How can food and beverages, changes of clothing, portable toilets, and first aid for minor injuries be provided?

One of the most important items to have on hand is a map of the water system with all valve locations identified. If one does not currently exist, draw a temporary one until a more complete map can be developed.

### **10.7 Procedures to Shut Down or Isolate Components of the System - Wells, Chemical Treatment Plants, Storage, Pumps**

The emergency response plan should contain information on how to shut down and isolate portions of the water system if necessary. Many times, most of the water system can continue in operation while an emergency is addressed on a portion of the system. This requires, as mentioned above, a good set of maps of the system with all valve locations well marked. Access to and function of these valves should be checked during routine maintenance to be certain they can still be located and operated.

Instructions on operation of the system or of a specific component could be posted on the wall of the facilities, so someone else could shut it down in an emergency if the person who normally operates the system is not available.

### **10.8 Coordination Procedures**

The Department of Military Affairs, Disaster and Emergency Services (DES) Division and DEQ assist in coordinating federal, state, and local services during emergencies. The county emergency services coordinator can be contacted to assist in planning how the water system and their office will interact in the event a disaster threatens the water supply.

The DES and the county emergency services coordinator can be very helpful in reviewing an emergency response plan and providing opportunities for those plans to be collaborative and practiced. They also maintain a survey of resources within the area, which will be helpful in locating or identifying equipment to be used during an emergency. In any emergency, it will be necessary to coordinate activities with DES personnel at the state or county level and DEQ personnel. The DEQ Public Water Supply Section should be notified immediately if a situation occurs that may result in contaminated water being served to the public or if the operations of the system are affected. Coordination with many other state and local officials and critical customers may also be necessary depending on the extent of the disaster. DEQ PWS staff can assist water systems during an

emergency event by providing potential solutions for operational or response concerns and by advising on regulatory issues or compliance measures.

### **10.9 Procedures to Communicate with Water Users**

The emergency response plan should contain procedures for letting the water users know if the water is contaminated and where or how they can obtain safe drinking water. Critical customers should be contacted directly. A spokesperson should be identified to handle the information that is to be delivered to the public. This person is often called the Public Information Officer (PIO). This may best be assigned to someone other than the operator in order to free the operator's time for necessary system operations. This person should be trained in public speaking and be coached in what the joint message is to the community. Training courses and material are available for this identified person or persons.

For small systems, how the information would be distributed or broadcast will vary. For systems serving highway rest areas, schools, restaurants, bars, and motels, this may be easily accomplished by posting notice or word of mouth and then shutting down access to the water. For subdivisions, mobile home parks and small communities, the information may have to be spread through use of a sound truck, by telephone calls, or direct distribution to the residents. Radio and TV might be helpful so local stations should be listed in the plan. Another option is the National Weather Service – All Hazard Emergency Message Collection System (HazCollect), previously known as Emergency Alert System (EAS), which allows government officials to broadcast public warnings in specific areas through multiple medias. Information going out to the consumers should include what the situation is, what the estimated time for restoring service might be, if the water is safe to drink, and where, if necessary, are alternate sources of drinking water.

A list of all those who should be notified immediately in case of an emergency should also be developed. This might include critical customers and agencies such as hospitals, schools, large industry, health department, fire department, military facilities, law enforcement, DES, DEQ, utility companies, board members, mayor or manager, contractors, volunteers, other utilities, radio, TV and newspapers, and any other emergency coordinating services in your area.

The table of Important Contacts, located at the end of Chapter 11, can be used as a starting point to accumulate this information. This chart should be the first page in an emergency response plan. Share it with others who may be involved in emergency response.

### **10.10 Sources of Emergency Water**

The plan should provide options for sources of safe drinking water during or following an emergency. Perhaps arrangements can be made to make a temporary connection with a neighboring water system or a tanker of potable water brought in for filling water bottles. Remember that not all tankers haul potable water. Do not use a tanker that has hauled chemicals or other hazardous substances—tankers dedicated for use of hauling potable water are the only ones that can be used. Also, know where your emergency supply is coming from and that it, too, is safe to drink.



**FIG 10.10. Emergency Water**

### **10.11 Disinfection and Restoration of Water Service**

Once the integrity of the water system has been reestablished all effected components of the water system (source, storage, treatment, and the distribution system) will need to be thoroughly flushed and disinfected. Guidelines for this procedure, including guidelines for the amount of chlorine to be added, should be prepared and inserted into the emergency response plan. Refer to Chapter 6: *Treatment of Groundwater* for this information and related references.

In the plan, describe how to disinfect and decontaminate the system. Identify dead ends that will need to be flushed. Prepare instructions that may need to be given to customers on the system about how to flush taps or to restrict water use for a period of time. Identify who will give the “all clear” signal when the system is back in operation and how it will be given. DEQ PWS can assist with the compliance measures and sampling requirements that need to occur after the system has been contaminated and while adequate service is in the process of being restored.

### **10.12 Funds**

All water system budgets should have a reserve fund for emergencies. However, there may be special procedures and documentation required to make use of these funds and the emergency response plan should explain the process. Also, there are emergency funds available for public water systems from state and federal agencies. Contact your emergency services coordinator and DEQ for information on possible sources of assistance.

### **10.13 Contracts and Agreements**

Formal contracts for potential supplies or assistance may or may not be necessary. However, it would be best to obtain written understandings that include the names and telephone numbers of persons to contact (both during and after working hours). An example list is included in Section 11.9.

The agreement should also include equipment and skills available, rental rates for equipment and wages for various skilled personnel, overhead costs, and liability coverage. Liability coverage for both system staff and potential helpers should be discussed to be sure that all are covered under emergency conditions.

As a MT WARN member, the liability, mutual aid, and resources available are addressed when the system signs the membership agreement and provides the system profile information. For more information, contact DEQ or visit [www.mtwarn.org](http://www.mtwarn.org).



## **Chapter 11: Water System Management**

The distinction between operations and management of a small public water supply system may not be clear-cut in all areas. Often the same individual is both operator and manager. At other times the operator may be the local contact while management decisions are made by an owner located elsewhere. For small municipalities, water districts, homeowners associations, schools and other small systems, the system operations may be separated from management performed by a board of directors or elected officials.

In any case, Montana requires each community and non-transient non-community public water supply system have a certified operator in responsible charge of the system. This individual is required to meet minimum criteria described in Chapters 1 and 2. All of the operator certification policies and requirements are intended to ensure the person responsible for the public water supply system has a reasonable level of knowledge about water quality, infrastructure, adequate water quantity and public health protection. A certified operator must ensure this knowledge is applied through the competent operation of a water system and that the individual(s) in charge of managing the system are informed of other items which must be addressed.

This chapter provides an overview of different aspects of public water supply system management. Depending on the system, some duties and decisions may fall on the certified operator and some may be the responsibility of the governing board.

### **11.1 Records Maintenance**

Records maintenance covers a variety of subjects, including maintaining records of:

- System infrastructure (maps of valve and hydrant locations, pipe sizes and locations);
- Equipment purchase, repair and maintenance;
- Monitoring results, including violations received or public notices given, for a minimum of *10 years*;
- Leak repair locations and dates;
- Water treatment, including any related chlorine residuals, fluoride levels or other required monitoring results;
- Source production, including static and pumping water levels, flow and water use;
- Consumer complaint locations, dates, reason for the complaints, and findings;
- Monitoring waivers granted by DEQ (must be kept for 3 years beyond their expiration date).

If an item surfaces for which you are unsure if records must be kept, evaluate it in terms of whether it would be useful to someone trying to find out what you have done or what might need to be done for the system. Historical records are also very useful for documenting changes that occur in water use, water availability and system condition.

### **11.2 Rate Structuring**

Rate structures are an important part of water system management because they determine whether financial needs for operations, capital costs, and reserves are met. Water rates must be set using an adequate and fair rate structure. Since small systems do not have the benefit of a large number of users covering operations and maintenance costs, they must also address a generally larger cost per consumer rate base.

Operating costs which must be covered include wages, electricity, chemical costs, maintenance parts, tools, monitoring fees, routine equipment replacement and loan payments. These are all part of operating and maintaining the water supply.

For more information on determining water rates and management practices, refer to EPA's Booklet, *Self Assessment for Small Publicly Owned Water Systems* and similar booklets for privately owned systems.



## ***Chapter 11: Water System Management***

---

Capital costs include those necessary to provide new or improved major equipment or facilities. They normally involve long-term debt service. Main extensions to serve new developments are often charged to the developer. Costs of new connections may also be charged to the new customer and set so the fee includes a share of the cost of the original system.

Water rates are generally expressed in dollars per 1000 gallons, dollars per 100 cubic feet, or as a flat rate. The rate schedule for water systems generally follows one of the following formats:

- *Flat Rate* where all customers pay the same rate, regardless of the amount of water used (e.g.: \$1.50 per each 1000 gallons);
- *Two-tiered Flat Rate* where customers are charged a minimum plus a rate for water used (e.g. a \$20.00, minimum plus 0.75 for each 1000 gallons used);
- *Declining Rate* where the charge per unit of water used declines as more water is used - this rate system is discouraged as it promotes excessive water use;
- *Two-Tiered Declining Rate* where an initial minimum charge covers a specified amount of water, then water used in excess of the minimum is charged at lower rates the more water used;
- *Increasing Rate* where the more water used, the higher the cost per unit of water;
- *Two-Tiered Increasing Rate* where a minimum fee for a specified volume of water is set and water use above that level is billed at increasing rates as more water is used.

The particular rate structure selected is based on the amount of water available to the system, treatment and delivery costs, and the related need for conservation programs. The amount of water available is dependent on source capacity, water rights issues, treatment, and possibly delivery capacity.

### **11.3 Planning for the Future**

Records of system maintenance needs, equipment age and condition, and leak repairs all contribute to a better understanding of the capital needs of a public water supply system. Part of the monies collected as user fees should be set-aside for these facility replacement costs and for a cash reserve. The anticipated costs of repair and replacement projects should be included in the formula used to establish the rate structure for the system.

### **11.4 Effective Communication**

Effective communications between town officials, water system managers and the general public are critical to effective management of a small public water supply system. Public relations are clearly a part of every certified operator's job so the operator must be able to discuss the purpose and operation of the water system facilities with a variety of audiences. These audiences might include school children, civic groups, regulators, or water system users with specific questions or complaints.

However, effective communications must go beyond presenting a professional appearance and serving as an authority on water system issues. It must include an open-book policy whereby consumers and managers are kept informed of the water quality, facility condition, monitoring and treatment performed and future needs of the system. In a 1993 survey of consumer attitudes on water quality issues, the American Water Works Association Research Foundation found that honest information about drinking water was one of the most important things wanted by the public. Not only was more objective information desired, but consumers provided this information tend to have more positive attitudes about the water utility and their drinking water. Required Consumer Confidence Reports are one vehicle of communication.

### **11.5 Consumer Confidence Reports**

The 1996 Amendments to the federal Safe Drinking Water Act required each community public water supply system to provide an annual "*Consumer Confidence Report*" on the source of their drinking water and the levels of contaminants found in the drinking water. The intent of the report is to increase consumer awareness of

the chemical testing performed on the water system, amounts detected, and maximum contaminant levels for those chemicals. The source of the drinking water would include a description of where the water is obtained and any treatment applied prior to water reaching consumers. CCRs are required for community water systems.

Specific requirements for consumer confidence reporting can be obtained by contacting the DEQ Public Water Supply Section. They are mentioned here to note that they can provide a valuable method of communication with water users and should be used to initiate other interaction when facility improvements or replacements are pending.

### **11.6 Public Notification**

Public notification differs from consumer confidence reporting in that public notification lets consumers know immediately if something has occurred which may affect their health if water is consumed. It is a required means of informing the public when water treatment has failed and monitoring reveals biological or chemical contamination, or when monitoring has not been performed or treatment has not been applied as required. Details on public notification requirements are found in the Administrative Rules of Montana (17.38.239) and on the DEQ website at <http://deq.mt.gov/wqinfo/pws/Publicnotificationrule.asp>.

### **11.7 Relief Operator**

All community and non-transient non-community public water supply systems must have an operator in responsible charge of the water system at all times. So what occurs when an operator is on vacation or off work due to illness or family emergency? Under these circumstances, it is important to have a relief operator available who is also certified, who can temporarily be in charge of the system until the regular operator returns.

Some systems handle this through having a back-up staff member. Others have arrangements with other local water systems whereby their operator has been trained to be knowledgeable of the system and can 'cover' while the regular operator is away. These arrangements work as long as the relief operator is familiar with the public water supply system components, treatment, and monitoring requirements, and is accessible to consumers and managers of the system.

Public water supply systems are encouraged to make arrangements for relief operator coverage for inevitable events as well as planned vacations and days off.

### **11.8 Economics of Public Water Systems**

Whether publicly or privately owned, all public water supply systems should be operated as a business. This includes careful accounting of expenditures, revenues and property. A public water system should operate in the black with profits going to one or more reserve accounts.

Public water supply system economics involve much more than chemical and electrical costs, staff payroll and user fees. A myriad of additional considerations are involved and must be carefully tracked to demonstrate financial solvency.

Some of the fees and expenditures a public water supply system would encounter include:

- Monthly routine coliform monitoring fees,
- Chemical contaminant monitoring fees (*plan at least three years into the future due to the cycle of required monitoring for some contaminants*),
- Public water supply system fees paid to DEQ annually,
- Certified Operator annual license renewal fees,
- Certified Operator continuing education seminar fees and travel costs,
- Insurance,

- Workers Compensation coverage,
- Plan review fees for upcoming projects,
- Professional Engineer fees for project design or planning,
- Equipment replacement funds
- Debt service

There are certainly many more costs which might be unexpected to an individual unfamiliar with the intricacies of water system management and operation. Each of these items must be taken under consideration when setting appropriate user fees. Several technical assistance providers in Montana offer training and assistance in public water supply system economics and planning. They are available for on-site and seminar-type assistance to help address financial issues. DEQ also provides information on system-specific monitoring requirements. Information on required monitoring is essential as it may be a significant portion of the costs faced by very small water systems.

### **11.9 Important Contacts for the Small Water System Operator**

Important contacts will include large system managers, laborers, specialists such as plumbers and electricians, pump suppliers, equipment suppliers, heavy equipment operators, DEQ staff, local county health contacts, analytical laboratories and technical assistance providers. The list will differ by system and geographic location, as well as by the expertise of the operator for the system. Figure 11.9 on the following page is provided as a suggested list of small water system contacts. It should be completed and posted in at least one prominent location for easy referral.

## Important Emergency Contacts

### Water System

Name	Title (include fax # and cell phone #)	Phone	Responsibility
	<b>Water System Operator</b>		
	<b>Relief Water Operator</b>		
	<b>Fire Department</b>		
	<b>Police or Highway Patrol</b>		
	<b>County Disaster and Emergency Services (DES) Coordinator</b>		
	<b>State DES</b>	<b>(406) 444-6911 (406) 444-6965 Fax</b>	<b>Coordinate emergency response</b>
	<b>State Dept. of Environmental Quality — Drinking Water</b>	<b>(406) 444-4400 Helena (406) 247-4445 Billings 406) 755-8985 Kalispell</b>	<b>Provide guidance to public water systems</b>
	<b>DEQ Certification Office</b>	<b>(406) 444-4584</b>	
	<b>County Sanitarian</b>		<b>Protect public health</b>
	<b>Consulting Engineer</b>		
	<b>Electrician</b>		
	<b>Plumber</b>		
	<b>Pump Repair</b>		
	<b>Chemical Supplier</b>		



## Glossary of Terms

**Action Level.** The concentration of lead or copper in water which determines, in some cases, the treatment requirements for source water or corrosion control.

**Acute Health Effects.** Impacts on health which occur over a short period of time after exposure to a contaminant.

**Aeration.** The process of adding air to water either by passing water through air or passing air through water.

**Air and Vacuum Release Valves.** Valves used to release trapped air or vacuums created in water pipelines.

**Alkalinity.** A measure of the water's capacity to neutralize acids.

**Annular Space.** The ring-shaped space located between the bore-hole of a well and the well casing.

**Apparent Color.** Color of water caused by suspended and dissolved particles.

**Aquifer.** A natural underground layer of porous, water-bearing materials (sand, gravel) usually capable of yielding a large amount of water.

**Artesian.** Water held under pressure in porous rock or soil confined by impermeable geologic formations. See confined aquifer.

**Backflow.** The unwanted reverse flow of water in a public water supply system.

**Back-pressure.** The normal flow in the distribution system is reversed due to an increase in the downstream pressure above the supply pressure.

**Back-siphonage.** Back-siphonage can occur when a negative pressure (below atmospheric pressure, or a vacuum) develops in the distribution system which can allow pollutants or contaminants to be siphoned into the water system.

**Breakpoint Chlorination.** Addition of chlorine to water until the chlorine demand has been satisfied. At this point, further additions of chlorine will result in a free residual chlorine which is directly proportional to the amount of chlorine added beyond the breakpoint.

**Calcium Hypochlorite.** A dry material of about 65% available chlorine which comes as a powder, granular or tablet form.

**Capacity (viability).** The financial, managerial and technical ability of a public water supply system to meet the requirements of the Safe Drinking Water Act.

**Capacity (design capacity).** Volume of water per unit time.

**Cavitation.** The formation and collapse of a gas pocket or bubble on the blade of an impeller or the gate of a valve. The collapse of the pocket or bubble drives water into the valve or impeller with enough force to cause pitting. It is accompanied by loud noises which sound like someone pounding on the impeller or gate with a hammer.

**Check Valves.** A special valve with a hinged disc or flap that opens in the direction of normal flow and is forced shut when flows attempt to go in the reverse or opposite direction of normal flow.

***Chemical Compatibility.*** The ability of pipe, valve or tank materials to be in contact with certain chemicals without losing strength or integrity. Corrosive chemicals in particular need compatible materials used for their storage and application.

***Chemical Containment.*** Berms, walls or other means by which potential chemical spills are limited to a controlled area.

***Chlorine Demand.*** The difference between the amount of chlorine added to water and the amount of residual chlorine remaining after a given contact time.

***Chlorine Gas.*** A greenish-yellow gas with a penetrating and distinctive odor used for disinfection. Chlorine gas is 100% available chlorine.

***Chronic Health Effects.*** Impacts on health which occur over a long period of time, either continuously or intermittently, generally caused after long-term and low-level exposure to a contaminant.

***Coliform Bacteria.*** See Total Coliform Bacteria and Fecal Coliform Bacteria.

***Community Public Water Supply System.*** A public water system which serves at least 15 service connections used by year-round residents or regularly serves at least 25 year-round residents.

***Conductivity.*** A measure of the ability of water to carry an electrical current. Conductivity increases as the total dissolved solids in water increase.

***Cone of Depression.*** The depression, roughly conical in shape, produced in the water table by the pumping of water from a well.

***Confined Aquifer.*** An aquifer in which groundwater is confined under pressure which is significantly greater than atmospheric pressure.

***Consolidated Deposit.*** A geologic material whose particles are stratified (layered), cemented or firmly packed together (hard rock).

***Consumer Confidence Report.*** An annual report to consumers by each community public water supply system on the source of their water and the levels of contaminants found in the drinking water.

***Continuing Education Credits (CECs).*** Credits earned by certified operators through attendance at or participation in approved training events. Continuing Education Credits are required for maintaining certified operator status.

***Corrosion.*** The gradual decomposition or destruction of a material by chemical action, often due to an electrochemical reaction. Corrosion may be caused by: 1) stray current electrolysis, 2) galvanic corrosion caused by dissimilar metals, or 3) differential concentration cells.

***Corrosivity.*** An indication of the corrosiveness of a water. The corrosiveness of a water is defined by the water's pH, alkalinity, hardness, temperature, total dissolved solids, and the dissolved oxygen concentration.

***Cross-Connection.*** Any actual or potential connection between a drinking (potable) water system and an unapproved water supply or other source of contamination.

**Dechlorination.** The deliberate removal of chlorine from water. The partial or complete reduction of residual chlorine by any chemical or physical process. A commonly used chemical dechlorinating agent is sodium thiosulfate.

**Disinfection.** The process designed to kill most microorganisms in water, including essentially all pathogenic (disease-causing) bacteria and viruses.

**Drawdown.** 1) The drop in the water table or level of water in the ground when water is being pumped from a well. 2) The amount of water used from a tank or reservoir. 3) The drop in the water level of a tank or reservoir.

**Exemption.** A state-granted relief for a public water supply system which allows the system to not meet a specific MCL, treatment technique requirement, or both, if certain conditions exist. The conditions include consideration of why the requirement cannot be met and that there not be any unreasonable risk to public health as a result of the exemption.

**Fecal Coliform Bacteria.** Bacteria found in the intestinal tracts of warm-blooded animals. The presence of high numbers of fecal coliform bacteria in a water body can indicate the recent release of untreated sewage and/or the presence of animal feces. These organisms may also indicate the presence of pathogens that are harmful to humans.

**Flow Meter.** A mechanical device which measures the amount of water passing through a given pipe. Flow is typically recorded as gallons per minute or cubic feet per second. Total flow and rate of flow are commonly recorded by a flow meter.

**Fluoridation.** The addition of a chemical to increase the concentration of fluoride in drinking water to a predetermined optimum limit to reduce the incidence of tooth decay in consumers.

**Foot Valve.** A special type of check valve located at the bottom end of the suction pipe on a pump. The valve opens to allow the flow of water when the pump operates and closes then the pump shuts off to prevent water from flowing out of the suction pipe.

**Free Available Chlorine Residual.** The portion of the total available chlorine residual remaining in water after chlorination. This does not include chlorine that has combined with ammonia, nitrogen or other compounds.

**Free Chlorine Residual.** See 'free available chlorine residual'.

**Gaining Stream.** See Receiving Stream.

**Galvanic Corrosion.** Corrosion caused by the electrochemical reactions created when two dissimilar metals are in contact with each other.

**Granular Activated Carbon (GAC).** Granules of adsorptive carbon obtained by heating carbon (such as wood). These granules have a high capacity to selectively remove certain trace and soluble materials from water.

**Groundwater Under the Direct Influence of Surface Water (GWUDISW).** Any water beneath the surface of the ground with: 1) significant occurrence of insects, microorganisms, algae or large-diameter pathogens such as *Giardia lamblia*, or 2) significant and relatively rapid shifts in water characteristics such as turbidity, temperature, conductivity, or pH which closely correlate to climatological or surface water conditions.



**Grout.** Cement or other suitable material used to fill the annular space between the well casing and the bore hole.

**Hardness.** A characteristic of water caused mainly by the presence of calcium and magnesium salts which prevent soap from lathering and may interfere with some industrial processes. Some references define hard water as that having greater than 100 mg/L hardness as calcium carbonate.

**Head Condition.** The vertical distance (in feet) equal to the pressure (in psi) at a specific point. The pressure head is equal to the pressure in psi times 2.31 ft/psi.

**Heterotrophic Plate Count (HPC).** The number of colonies of heterotrophic bacteria grown on selected media at a given temperature and incubation period. Heterotrophic organisms use organic material synthesized by other organisms for energy and growth.

**Hydraulic Conductivity.** The ease with which water can pass through deposits and thus transmit water to a well.

**Hydraulic Gradient.** The slope of the hydraulic grade line. This is the slope of the water surface in an open channel, the slope of the water surface of the groundwater table, or the slope of the water pressure for pipes under pressure.

**Hydraulics.** The study of liquid in motion and under pressure.

**Hydrologic Cycle.** The movement of water in and on the earth and atmosphere through processes such as precipitation, infiltration, runoff, and evaporation.

**Hydropneumatic Pressure Tank.** A water storage tank in which the water system's water pump is automatically controlled (started and stopped) by the air pressure in a compressed-air tank.

**Indicator Bacteria.** Bacteria analyzed for in water (such as coliform bacteria) which serve as a surrogate indicator for the potential presence of pathogens in the same water.

**Iron Bacteria.** A specialized group of bacteria capable of using iron for metabolic processes and which commonly cause red-water, slime or encrustation in well water systems.

**Iron (Fe).** An inorganic chemical which causes reddish-brown stains on laundry and fixtures if present above about 0.3 mg/L.

**Licensed Water Well Driller.** A water well driller meeting the requirements for licensing and obtaining a license from the Montana Board of Water Well Contractors.

**Losing Stream.** A reach of a river or stream or other surface water body from which water infiltrates into the groundwater aquifer.

**Manganese (Mn).** An inorganic chemical which causes brownish-black staining on laundry and fixtures if present in water at concentrations above about 0.05 mg/L.

**Material Safety Data Sheets (MSDS).** Informational documents provided by chemical suppliers which detail hazards of the chemical, handling requirements, spill remediation and other safety issues pertinent to the specific product.

**Maximum Contaminant Level.** The maximum permissible level of a contaminant in a public water supply system.

**Maximum Contaminant Level Goal (MCLG).** The maximum level of a contaminant in drinking water at which no known or anticipated adverse effect on the health of persons would occur, and which allows an adequate margin of safety. Maximum contaminant level goals are nonenforceable health goals.

**Methemoglobinemia.** Also referred to as “blue baby syndrome” is an ailment caused by high levels of nitrate or nitrite in water. When ingested, these compounds interfere with the ability of blood to carry oxygen and result in a blue color of afflicted individuals. It can be fatal for the unborn, infants and young children.

**Microscopic Particulate Analysis.** A specialized analysis of particles in water which are trapped on a cartridge filter. The particles (algae, insects and other debris) are assessed to determine relative populations and types of organisms present. It is useful for GWUDISW determinations and for assessing the performance of water filtration plants.

**Milligrams Per Liter (mg/L).** A measure of the concentration of a dissolved substance. A concentration of one milligram per liter means one milligram of a substance is dissolved in each liter of water. For practical purposes, this unit is equal to parts per million since one liter of water is equal in weight to one million milligrams.

**Minimum Design Standards.** Minimum criteria for construction and design established to ensure provision of a sufficient quantity of water from the source through a reliable treatment and distribution system.

**Multiple Barrier Concept.** A concept for public health protection which involves several steps or barriers to prevent the passage of contaminants to a potable water supply. The independent steps include source protection, treatment, disinfection and assurance of distribution system integrity.

**Nitrates and Nitrites.** Inorganic chemical contaminants of water systems which pose an immediate threat to infants under six months of age because they may lead to a condition known as methemoglobinemia. Nitrate reverts to nitrite in the human body, which causes the condition.

**Non-Transient Non-Community Public Water Supply System.** A public water supply system which regularly serves at least 25 of the same non-resident persons per day for more than six months per year.

**Parts Per Million (ppm).** See milligrams per liter.

**Pathogenic.** An organism which is capable of causing disease.

**pH.** The numerical measure of the hydrogen ion concentration in water with a scale of 0 to 14. Neutral is pH 7; values below 7 are acidic, and values above 7 are alkaline.

**Piezometric Surface.** See potentiometric surface.

**Pitless Adapter.** An adapter which attaches to the well casing and allows a submersible pump to discharge from below ground level. This eliminates the need for well pits or houses over the wellhead.

**Point of Application.** The point at which a chemical is applied to water, after thorough mixing of the chemical into the water stream.

**Porosity.** The ratio (usually expressed as a percentage) of the volume of openings in soils or rocks to the total volume of the soil or rock.

**Positive (constant) Displacement Pump.** A type of piston, diaphragm, gear or screw pump that delivers a constant volume with each stroke. They are often used as chemical solution feeders.

**Potentiometric Surface.** The surface defined by the elevation above sea level to which water rises in a well that is open to the atmosphere.

**Pressure Zones.** Hydraulically defined areas of a distribution system which pull from a given storage reservoir or water source.

**Primacy.** Primary enforcement authority granted to states for implementation and enforcement of federal regulations.

**Primary Standard.** An enforceable drinking water standard.

**Pump Curves.** Graphic plots of data which indicate the expected performance of a specific pump at specified head and flow conditions.

**Pumping Water Level (or dynamic level).** The vertical distance in feet from the centerline of the pump discharge to the level of the free pool while water is being drawn from the pool.

**Radioactivity.** The emission of alpha or beta particles, or gamma rays from a natural or man-made element. Radioactivity is a public health concern due to the cancer-causing potential of these particles and rays.

**Receiving Stream.** The section of a stream, river or other surface water body which receives groundwater discharging from an aquifer.

**Recharge.** Replenishment of water in an aquifer.

**Repeat Samples.** Bacteriological quality samples collected after receiving results that routine samples were unsatisfactory. These are also often referred to as "Check Samples".

**Replacement Sample.** Bacteriological quality samples collected to replace a routine sample which was too old (beyond the 30-hour sample-to-analysis time limit) or had interference from heterotrophic plate count bacteria.

**Routine Coliform Monitoring.** Periodic, usually monthly, bacteriological quality monitoring required of all public water supply systems.

**Safe Drinking Water Act.** An Act passed by Congress in 1974. The Act establishes a cooperative program among local, state and federal agencies to insure safe drinking water for consumers.

**Sample Site Plan.** A bacteriological sample collection location plans required of all community public water supply systems which identify the locations used for routine monitoring and any necessary repeat monitoring.

**Saturated Zone.** The area below the water table where all open spaces are filled with water.

**Semi-Consolidated.** A term used to describe geologic formations which are partially cemented such as some limestone and sandstones.

***Sequestering Agents.*** Chemical agents used to prevent precipitation of some metals (such as iron and manganese) from water.

***Sodium.*** An inorganic chemical compound (Na) commonly found in table salt and some natural waters. High sodium concentrations in water may be of interest to persons on sodium restricted diets.

***Sodium Hypochlorite.*** One of several forms of chlorine which is commonly used for chlorination of public water supply systems. Sodium hypochlorite is available in about a 6.5 percent chlorine solution.

***Source Water Protection.*** Programs for protection of watersheds and well head protection zones intended to identify, control, and thereby reduce the potential for contamination or degradation of sources of drinking water.

***Special Samples.*** Bacteriological quality samples collected for reasons other than compliance monitoring. Examples would be samples collected to check the quality of water in a repaired main or new storage tank before the water therein is returned to service.

***Specific Capacity.*** A measure of well yield per foot of drawdown expressed as gallons per minute per foot of drawdown.

***Static Water Level.*** 1) The elevation or level of the water table in a well when the pump is not operating. 2) The level or elevation to which water would rise in a tube connected to an artesian aquifer, or basin, or conduit under pressure.

***Sterilization.*** The removal or destruction of all microorganisms.

***Sulfide.*** Also referred to as hydrogen sulfide gas (H<sub>2</sub>S). A colorless gas with the distinctive smell of rotten eggs.

***Surface Water.*** Water above the surface of the ground including, but not limited to, lakes, rivers, streams, wetlands, wastewater, flood water, and ponds.

***Surface Water Treatment Rule (SWTR).*** A federal regulation specifically targeting removal of particulates and control of pathogenic organisms (such as *Giardia lamblia*) encountered in surface water supplies and groundwater under the direct influence of surface water.

***Total Coliform Bacteria.*** A group of indicator bacteria used to detect the possible contamination of water by pathogenic organisms.

***Transient Non-community Public Water Supply System.*** A non-community water system that does not serve 25 of the same nonresident persons per day for more than six months per year.

***Trihalomethanes.*** A group of chemical compounds which are known or suspected cancer-causing agents. They are typically formed as byproducts of the disinfection process.

***True Color.*** Color remaining in water after particles have been filtered from the water sample. True color is composed of color-causing dissolved constituents.

***Tuberculation.*** The development or formation of small mounds of corrosion products (rust) on the inside of iron pipe. These mounds (tubercles) increase the roughness of the inside of the pipe thus increasing resistance to water flow.

***Turbidity.*** The cloudy appearance of water caused by the presence of suspended and colloidal matter.

***Unconfined Aquifers.*** An aquifer containing water that is not under pressure; the water level in the well is the same as the water table outside the well.

***Unconsolidated Deposits.*** Deposits composed of loose rock or mineral particles of varying sizes. Examples include clay, silt, sand and gravel.

***Unsaturated Zone.*** The area between the land surface and water table in which the pore spaces are only partially filled with water. Also called “zone of aeration”.

***Variable Displacement Pumps.*** Pumps for which as head increases, the flow from the pump decreases. Examples include centrifugal, jet, and air lift pumps.

***Variance.*** A state-granted relief for a public water supply system which allows the system to not meet a specific MCL if certain conditions exist. The conditions include installation of best available technology which fails to treat the water to the level required by the MCL and that there not be any unreasonable risk to public health as a result of the variance.

***Water Table.*** The level of groundwater; the upper surface of the zone of saturation.

***Water Hammer.*** The sound like someone hammering on a pipe that occurs when a valve is opened or closed very rapidly. It is caused by the rise and fall of water pressure caused by the rapid change in valve position.

***Watershed.*** The land area that drains into a stream or river. An area that contributes runoff to a specific delivery point.

***Well Cap.*** A device installed on the upper terminal end of a well casing which prevents entry of insects, rodents and precipitation to the well.

***Well Seal.*** A type of well cap intended for use indoors. The seal has a rubber gasket which fits inside the well casing and is held in place by metal plates.

***Well Vent.*** A downturned, screened opening to the well casing which allows entry of air during drawdown and release of air during water table recovery. They serve the important role of preventing contaminants from being sucked into the well during creation of a vacuum during drawdown, and prevent uncontrolled release of air when the water table recovers and air is forced out of the casing.

***Well Yield.*** The quantity of water pumped from a well per unit time, usually in gallons per minute (gpm)

***Zone of Contribution.*** The area of the aquifer that recharges the well.

***Zone of Influence.*** The land area above the cone of depression of a well which contributes groundwater to the production well.

**Bibliography**

American Water Works Association Research Foundation, *Consumer Attitude Survey on Water Quality Issues*, Denver, CO (1993).

American Water Works Association (AWWA), *Principles and Practices of Water Supply Operations Series*:

- *Water Sources*
- *Water Treatment*
- *Water Transmission and Distribution*
- *Water Quality*
- *Basic Science Concepts and Applications*

Denver, CO (2003)

California State University, Sacramento, *Small Water System Operation and Maintenance*, 4<sup>th</sup> Edition, Hornet Foundation, Inc., Sacramento, CA (1999).

California State University, Sacramento, *Water Distribution System Operation and Maintenance*, 5<sup>th</sup> Edition, Hornet Foundation, Inc., Sacramento, CA (2005).

California State University, Sacramento, *Water Treatment Plant Operation, Volume 1*, 6<sup>th</sup> Edition, Hornet Foundation, Inc., Sacramento, CA (2008).

California State University, Sacramento, *Water Treatment Plant Operation, Volume 2*, 5<sup>th</sup> Edition, Hornet Foundation, Inc., Sacramento, CA (2006).

Montana Department of Environmental Quality, *Montana Source Water Protection Guidance Manual*, Montana Department of Environmental Quality, Planning, Prevention and Assistance Division, Helena, MT (1998).

Montana Department of Environmental Quality, “Drinking Water Regulations Summary Community and Non-Transient Non-Community Water Systems”, Montana Department of Environmental Quality, Public Water Supply Section, Helena, MT (2009).

Montana Department of Environmental Quality, “Circular DEQ-3, Standards for Small Water Systems”, Montana Department of Environmental Quality, Public Water Supply Section, Helena, MT (2006).

Montana State Library, *Montana Ground-Water Atlas*, Montana Natural Resource Information System, Helena, MT (1997).

United States Environmental Protection Agency, *Drinking Water Glossary: A Dictionary of Technical and Legal Terms Related to Drinking Water*, U.S. EPA, EPA 810-B-94-006 (June, 1994).

## ***Bibliography***

---

States Environmental Protection Agency, *Drinking Water Handbook for Public Officials*, U.S. EPA, EPA-810-B-92-016 (December, 1992) (also available through the American Water Works Association).

United States Environmental Protection Agency, *Manual of Small Public Water Supply Systems*, U.S. EPA Office of Water (WH-550), EPA 570/9-91-003 (May, 1991).

United States Environmental Protection Agency, *Safe Drinking Water Act Amendments of 1996: General Guide to Provisions*, U.S. EPA, Office of Water, EPA 810-S-96-001 (1996).

U.S. Environmental Protection Agency, *Seminar Publication: Wellhead Protection: A Guide for Small Communities*, EPA/625/R-93/002, Washington D.C. (1993).

United States Environmental Protection Agency, *Technologies for Upgrading Existing or Designing New Drinking Water Treatment Facilities*, U.S. EPA/625/4-89/023 (March, 1990).

**Recommended References and Places of Interest to Water Operators**

**MONTANA SPECIFIC INFORMATION**

**Supplied by the DEQ for Exam Preparation**

*"Study Guides Specific to Six Different Certification Classes."* Montana DEQ

*"Summary of Drinking Water Regulations, Community and Non-transient Non-community Water Systems"* Montana DEQ

*"Formula Sheet for Operators."* Montana DEQ

*"Ground Water Manual for Small Water Systems."* Montana DEQ

*"Basics Course for Small Public Drinking Water Systems – Montana"* CD, Montana DEQ

**Available Upon Request**

*"Circular WQB-1, Standards for Water Works."* DEQ Design Standards available on request

**Montana DEQ, Water Quality Info Website:**

<http://deq.mt.gov/wqinfo/index.asp>

**OTHER APPLICABLE REFERENCE SOURCES FOR THE ABC EXAMINATIONS**

**AMERICAN WATER WORKS ASSOCIATION (AWWA)**

- *Water Transmission and Distribution*
- *Water Distribution Operator Training Handbook*
- *Basic Science Concepts and Applications*
- *Water System Security, A Field Guide*
- *Water Quality*

Principles and Practices of Water

Supply Operations Series:

- *Water Sources*
- *Water Treatment*
- *Water Transmission and Distribution*
- *Water Quality*
- *Basic Science Concepts and Applications*

Other AWWA References:

*Water Quality and Treatment*

*Water System Security, A Field Guide*

To order, contact: American Water works Association  
6666 West Quincy Ave, Denver, CO 80235  
Web site: [www.awwa.org](http://www.awwa.org)  
Phone: (800) 926-7337

Fax: (303)347-0804  
Email: [custsvc@awwa.org](mailto:custsvc@awwa.org)



## References and Places of Interest

### ASSOCIATION OF STATE DRINKING WATER ADMINISTRATORS (ASDWA) AND NATIONAL RURAL WATER ASSOCIATION (NRWA)

- *Security Vulnerability Self Assessment Guide for Small Drinking Water Systems*

To order, contact: ASDWA  
1401 Wilson Blvd Ste 1225, Arlington, VA 22209  
Web site: [www.asdwa.org](http://www.asdwa.org) Fax: (703)812-9506  
Phone: (703) 812-9505 Email: [info@asdwa.org](mailto:info@asdwa.org)

### CALIFORNIA STATE UNIVERSITY, SACRAMENTO (CSUS) FOUNDATION, OFFICE OF WATER PROGRAMS

- *Water Distribution System Operation and Maintenance*
- *Small Water System Operation and Maintenance*
- *Water Treatment Plant Operation, Volumes I and II*
- *Utility Management*
- *Manage for Success*

To order, contact: Office of Water Programs  
California State University, Sacramento  
6000 J Street, Sacramento, CA 95819-6025  
Web site: [www.owp.csus.edu](http://www.owp.csus.edu) Fax: (916) 278-5959  
Phone: (916) 278-6142 Email: [wateroffice@owp.csus.edu](mailto:wateroffice@owp.csus.edu)

### REGULATIONS

*Code of Federal Regulations, Title 40, Part 141 (www.gpo.gov)*

★ While the DEQ will endeavor to assist you in the preparation for this exam by providing this study guide and related materials, it is your responsibility to find the appropriate reference materials and spend the necessary time to prepare for the exam.

## **Index**

### **A**

Action Levels 2-7  
Activated Carbon 6-13  
Acute Health Effects 1-1, 1-2, 2-7  
Aeration 6-12, 6-13  
Air Gap 7-6, 8-4, 8-6, 8-7  
Air Release Valves. *See* Valves  
Algae 4-2, 6-10, 6-13  
Alkalinity 3-6, 6-15  
Annular Space 5-4, 5-8  
Aquifer 3-1 to 3-5, 3-6, 4-1 to 4-2, 4-4, 5-3 to 5-4, 5-8 to 5-13, 6-1, 6-7  
    formations and deposits 3-3  
    types of 3-3 to 3-4  
Artesian Well 3-3, 5-11

### **B**

Backflow Prevention 2-9, 7-2, Chapter 8  
Bacteriological Quality Monitoring. *See* Microbiological Contaminant Monitoring

### **C**

Calculations 7-7 to 7-9  
    disinfectant 6-8, 6-9, 7-8  
    pressure head 7-9  
Capacity 2-1, 5-2, 5-6, 5-8, 5-9 to 5-11, 5-13, 7-5, 11-2  
Cavitation 7-3  
Certified Laboratories 2-3, 2-6, 2-8  
Check Valves 8-5  
Chemical  
    compatibility 9-2, 9-3  
    containment 2-9, 2-10, 8-4, 9-3  
Chlorination  
    breakpoint 6-2 to 6-3  
    methods of Chapter 6  
    safety 2-10, 6-9, 6-10, 9-3  
Chlorine  
    contact time 6-1 to 6-3, 6-7, 6-10  
    demand 6-2  
    gas scrubbers 2-9, 2-10  
    residual 2-6, 2-8, 6-2, 6-9 to 6-10  
    types of 6-3  
        calcium hypochlorite 6-4, 6-6, 6-7, 6-8, 6-12  
        chlorine dioxide 6-14  
        chlorine gas 6-4 to 6-5  
        sodium hypochlorite 6-4, 6-6 to 6-7

## ***Index***

---

Chronic Health Effects 1-1 to 1-2, 2-7  
Coatings  
    pipes 7-1 to 7-3  
Coliform Bacteria 2-4, 5-17  
    fecal coliform bacteria 2-4, 4-3, 10-4  
    total coliform bacteria 2-4 to 2-6, 6-1, 6-5, 6-7 to 6-8, 6-14 to 6-15, 7-11 to 7-12, 11-3  
Color 1-2, 2-6, 2-7, 3-2, 3-7, 6-10 to 6-12  
Community Water Systems 1-2  
Compatibility 9-2 to 9-3  
Cone of Depression 3-4, 5-1  
Confined Space 9-1, 9-5  
Consumer Confidence Reports 11-2, 11-3  
Consumption of water 1-1, 2-9  
Continuing Education Credits (CECs) 1-3 to 1-4  
Corrosion 2-2, 2-7, 5-11, 5-13, 6-15, 7-1 to 7-2, 7-6, 7-10  
Cross-connection 2-1, 2-9, 4-3, 6-1, 6-13, Chapter 8  
Cryptosporidium 4-1, 4-2, 4-3, 4-4, 6-1, 6-4, 6-10

## **D**

Dechlorination 6-5  
Design Standards for Water Works 2-1, 2-3, 5-4, 5-6, 6-12, 10-2  
Discharge of Chlorinated Water 6-5 to 6-7, 6-16, 7-11  
Disinfection  
    emergency 6-1, 6-4, 6-7  
    methods of 2-10, 6-1 to 6-10, 6-13 to 6-15, 10-7 *See also* chlorination  
    record keeping 6-5  
Distances to Wells 7-10  
DPD Method 2-6, 6-3  
Drawdown 3-4, 5-3, 5-6, 5-13

## **E**

Electrical Safety 5-10, 9-2  
Electrochemical Reaction 6-15  
Emergency Response Plans 10-1 Chapter 10

## **F**

Filtration  
    cartridge 6-14  
Flow Meters 5-9  
Fluoridation 2-6  
Fluoride 2-6, 6-14, 11-1  
    Levels 2-6  
Free Available Chlorine Residual 2-6, 6-2

## **G**

Galvanic Corrosion. *See* Corrosion: types of

## ***Index***

---

Gas Scrubber 2-9, 2-10  
Giardia 2-3, 4-1 to 4-2, 4-3, 4-4, 6-1, 6-10  
Greensand 6-12  
Groundwater  
    characteristics of 3-1 to 3-4, 3-7 to 3-8, 4-2  
    movement of 3-1 to 3-4, 5-4  
    protection of 2-1, 2-2, 4-1 to 4-6, 8-1  
    treatment of 6-1  
Groundwater Under the Direct Influence of Surface 4-1 to 4-2, 4-4, 5-3  
Grout 5-3, 5-5, 5-7, 5-8

## **H**

Hardness 2-7, 3-7, 6-1, 6-15  
Hazards  
    safety 9-1, 9-4 to 9-8  
Head Conditions 5-8  
Hepatitis 2-5, 4-3  
Hydrants 2-11, 5-7, 6-7, 6-13, 7-1, 7-4, 7-12, 7-13, 8-2, 8-4, 8-7  
    flushing 7-4, 7-12, 7-13  
Hydraulic Conductivity 3-4  
Hydraulic Gradient 3-4  
Hydrologic Cycle 3-1 to 3-2  
Hydropneumatic Pressure Tanks 6-8, 7-4, 7-5. *See also* Storage  
Hypochlorinators. *See* Chlorination: methods of

## **I**

Indicator Bacteria 2-4, 4-5  
Ion Exchange 6-11 to 6-12, 6-14 to 6-16  
Iron 2-6, 2-7, 3-6, 3-7, 6-1, 6-2, 6-6, 6-7, 6-10 to 6-13, 6-15  
Iron Bacteria 3-7, 6-6 to 6-7, 6-15

## **L**

Laboratory  
    certified 2-3, 2-10  
Leak Detection 7-9  
    chlorine gas 6-9, 9-3  
    distribution system water loss 7-11  
Licensed Water Well Driller 2-3  
Lifting Safety 9-3, 9-7  
Losing Stream 3-6  
Lubricants  
    pump 5-12

## **M**

Main, Water  
    disinfection 2-6, 7-11

## ***Index***

---

repair and replacement 2-3, 7-13, 7-9, 9-5

### Maintenance

programs 5-12, 6-4 to 6-6, 6-13, 7-3, 7-11 to 7-12, 9-1, 10-5

pump 5-11 to 5-12, 6-5, 7-6

recordkeeping 5-2, 5-12, 7-12, 7-12, 11-1, 11-2. *See also* recordkeeping

well 5-12 to 5-14

Manganese (Mn) 2-7, 3-6, 3-7, 4-5, 6-1, 6-2, 6-7, 6-10 to 6-13, 6-15

Material Safety Data Sheets (MSDS) 9-2, 9-3, 9-7

Maximum Contaminant Level 2-2, 2-7 to 2-8, 6-14, 11-3

Maximum Contaminant Level Goal 2-2

### Meters

flow 5-9

water 2-9

Methemoglobinemia 2-5, 6-11

### Microbiological Contaminant Monitoring

repeat samples 2-3 to 2-5

replacement sample 2-5

routine coliform monitoring 2-4

sample site plan 2-4

special samples 2-4

Microscopic Particulate Analysis 4-2

Minimum Design Standards 2-1, 2-3

Monitoring Requirements 2-5, 2-8

Montana Groundwater Atlas 3-1, Bibliography-2

Montana Operator Code of Ethics 1-3

Multiple Barrier Concept 2-2, 4-4 to 4-5

## **N**

Nitrates and Nitrites 1-1, 2-5

Non-Transient Non-Community Water Systems 1-2

## **O**

### Operator

need for 1-3, 6-3, 6-16, 7-1, 7-11, 10-1, 11-1, 11-3 to 11-5

Operator Certification 1-2 to 1-4, 2-1, 11-1

Oxygen Deficiency 9-5

## **P**

Pathogenic Organisms 2-4, 4-1, 4-3, 5-3, 6-1, 6-10

### Permit

chlorinated water discharge 6-5

Personal Safety 6-3, 6-4, 6-8, 6-9, Chapter 9

pH 2-7, 2-8, 3-7, 6-1, 6-12, 6-15

Pipes 2-2, 2-7 *See also* main: water

Pitless Adapter 5-5 to 5-7

Point of Application 2-6

Porosity 3-4

***Ground Water Manual for Small Water Systems***

## ***Index***

---

### Pressure

- calculations 7-9
- minimum 7-4, 7-9
- zones 2-4

Primacy 2-1, 2-9, 4-6

Primary Standard 2-2

Public Health 1-1 to 1-3, 2-1 to 2-2, 4-1, 4-3, 4-4, 6-1, 8-2, 11-1, 11-5

Public Health Service 2-1

Public Notice 2-3, 2-8, 5-2, 11-3

Public Water Supply Systems

types of

- community 1-1, 1-2
- non-transient non community 1-2
- transient non community 1-2

Pump Control Valves. *See* Valves

Pump Curves 5-8

Pumping Water Level 3-4, 5-5, 5-13, 5-14

Pumps, Types of 5-8 to 5-11

## **R**

Radioactivity 3-7, 4-4, 6-15

Rates, Water 11-1 to 11-2

Recordkeeping 7-15

## **S**

Safe Drinking Water Act 1-1, 2-1, 4-7

Safety 2-1, 2-10, 5-13, 6-3, 6-4, 6-8, 6-9, Chapter 9

Sample Site Plans 2-4

Sand Separator 6-14

Saturated Zone 3-2

Sequestering Agent 2-7, 6-12

Shields 9-6

Shoring 9-1, 9-4 to 9-5

Source Water Protection 2-2, 3-4, 4-1, 4-4 to 4-5, 10-3

Special Samples 2-5

Specific Capacity 5-5, 5-13

Springs 4-1

Static Water Level 3-4, 3-6, 5-3, 5-5, 5-13, 5-14

Sterilization 6-1

Storage

- chemical 6-5, 9-1, 9-1, 9-3

Storage Tanks

- disinfection 6-8, 6-9, 6-13
- hydropneumatic 7-4, 7-5
- security 7-5

Sulfide 2-10, 3-7, 6-1, 6-2, 6-10, 6-12, 6-13

Surface Water Treatment Rule (SWTR) 4-2

## ***Index***

---

### **T**

Taste and Odor 3-7, 6-7, 6-10, 6-11, 6-12 to 6-13, 7-6, 7-12  
Total Coliform Bacteria. *See* Coliform bacteria: total coliform bacteria  
Transient Non-Community Water Systems 1-2  
Treatment Technique Requirements 2-2  
Trenches  
    safety 9-5  
Trihalomethanes 6-11  
True Color 3-7  
Turbidity 2-8, 3-7, 4-2, 6-1, 6-10

### **U**

Ultraviolet Light 6-1, 6-4, 6-10  
Unsaturated Zone 3-2, 3-3, 3-6

### **V**

Valves  
    air and vacuum 5-9, 5-11, 7-2  
Vandalism  
    security against 10-1 to 10-2  
Variance 2-8  
Vents  
    well 5-5, 5-6, 10-2 to 10-4  
Virus 2-3, 4-2, 4-3, 6-1, 6-2, 6-3, 6-10  
Volatile Organic Chemicals 6-13

### **W**

Water Hammer 7-3, 7-10  
Water Rights 5-1, 5-2  
Water Table 3-2 to 3-4, 5-13  
Water Well Driller  
    licensed 2-3  
Waterborne 2-1, 4-1, 4-3  
Watershed Protection. *See* Source Water Protection  
Well. *See* pumps  
    abandoned 4-1, 4-2, 5-3, 5-8, 10-3  
    casing 5-3 to 5-6  
    construction 4-1, Chapter 5, 6-5  
    declining yield 5-12  
    drilling methods 5-3  
Wellhead Protection. *See* Source Water Protection

### **Z**

Zone of Contribution 3-5, 4-4  
Zone of Influence 3-4