



ENHANCE ★ PROTECT ★ CONSERVE

# Mississippi Advisory Commission on Marine Resources

April 16, 2021



ENHANCE ★ PROTECT ★ CONSERVE

# Employment, Contracts and Procurement Updates

## April 20, 2021

# Employment Updates

- Megan Fleming – Biological Program Coordinator – Finfish Bureau – 03.16.21
- Matt Murphy – Permitter IV – Coastal Wetlands and Mitigation Compliance Bureau – 03.16.21
- Todd Curry – Master Sergeant – Marine Patrol - 04.01.21
- Wyatt Webb – Corporal – Marine Patrol – 04.01.21
- Rachel Kistler – Permitter II – Coastal Wetlands and Mitigation Compliance Bureau – 04.05.21
- Yvette Timmons – Dispatcher I – Marine Patrol – 04.16.21



ENHANCE ★ PROTECT ★ CONSERVE

# Actions Update

## April 20, 2021



## Discussed at the March 2021 meeting:

MDEQ'S request for Permit Modification to modify an existing permit to construct subtidal reef habitat in Point Aux Chenes Bay in Jackson County, MS with the following additional condition:

- Marking of the reefs and the plan for maintaining the markings must be approved by MDMR prior to project completion.
- Commission recommended approval of the request.
- Director approved the request.

**Request for Permit by:  
MS Department of Environmental Quality  
File: DMR-200009**

- **Location: Near Big Island in the Back Bay of Biloxi, Harrison County**
- **Use District: (G) General Use District**
- **Agent: Alane Young, Covington Civil and Environmental, LLC**

# Project Description

- **Structure:**
  - **Breakwater**
    - 8,000 linear feet total
- **Purpose/Need:**
  - **NRDA Early Restoration Project – intended to accelerate restoration of injured natural resources and their services**
    - **Reduce erosion**
      - By diminishing energy of waves before they impact the shoreline
    - **Support secondary productivity**
      - By serving as high-profile reefs that can be colonized by bivalve mollusks, annelid worms, shrimp, crabs, and other benthic organisms







**SOURCES:**

1. Aerial image courtesy of USGS Earthstar Geographics SIO © 2016 Microsoft Corporation.
2. Survey provided by DIMCO, Inc. dated July 26 to August 10, 2016.
3. Navigation channel from drawings provided by U.S. Army Engineer District, Corps of Engineers, Mobile, Alabama dated February 5, 2016.

**HORIZONTAL DATUM:** Mississippi State Plane East, NAD83, U.S. Survey Feet.

**VERTICAL DATUM:** Mean Lower Low Water (MLLW).

**LEGEND:**

-  Segmented Breakwater Alignment
-  75' Offset from Navigation Channel
-  Cross Section Location (See Figure 4)

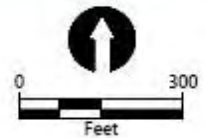



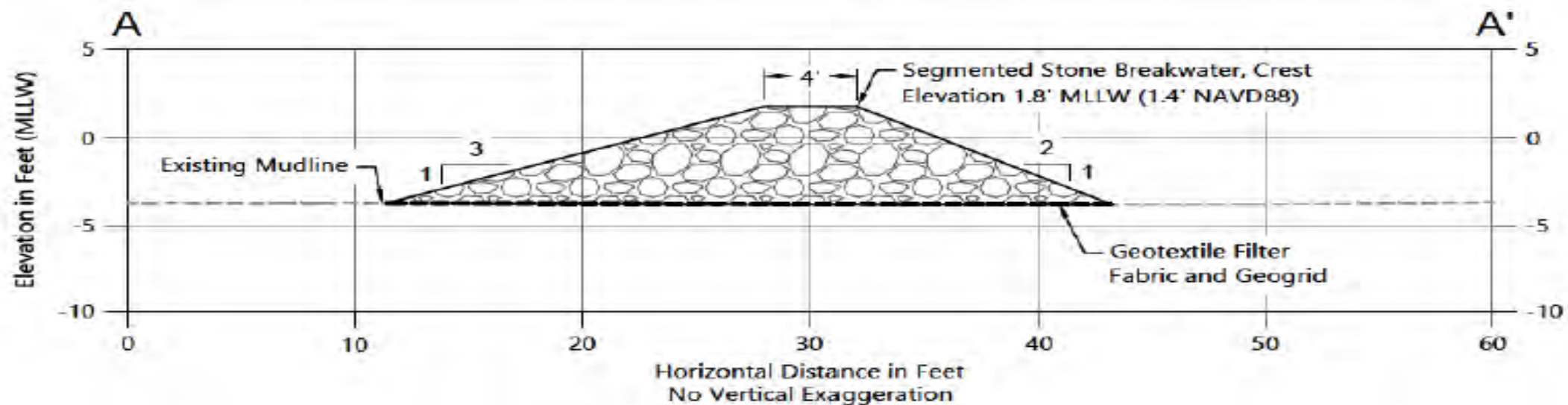

**Outer Breakwater**

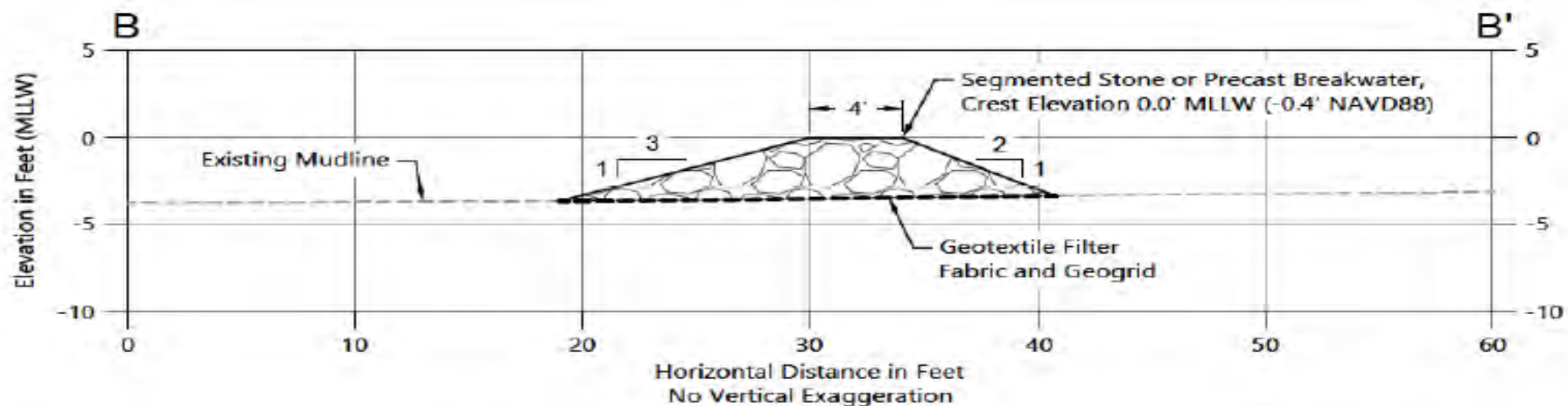

**Inner Breakwater**

- NOTES:
1. Inner breakwater to be constructed at bed elevations between -1.5 and -2.5 feet MLLW.
  2. Outer breakwater to be constructed at bed elevations between -2.5 and -3.5 feet MLLW.

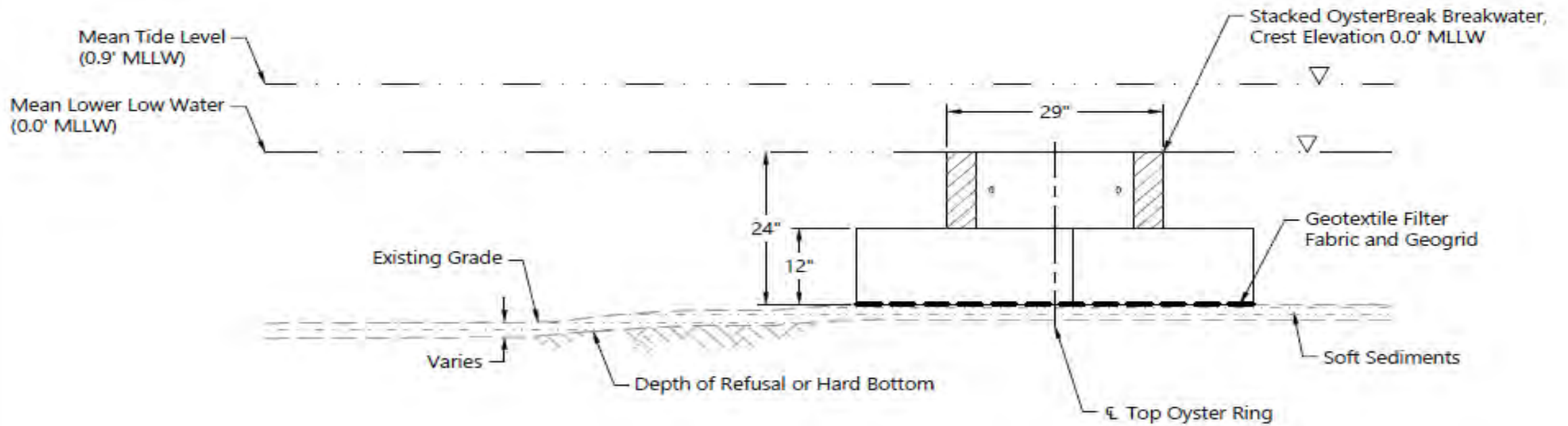

**Typical Section OysterBreak Breakwater Option**

Not to Scale

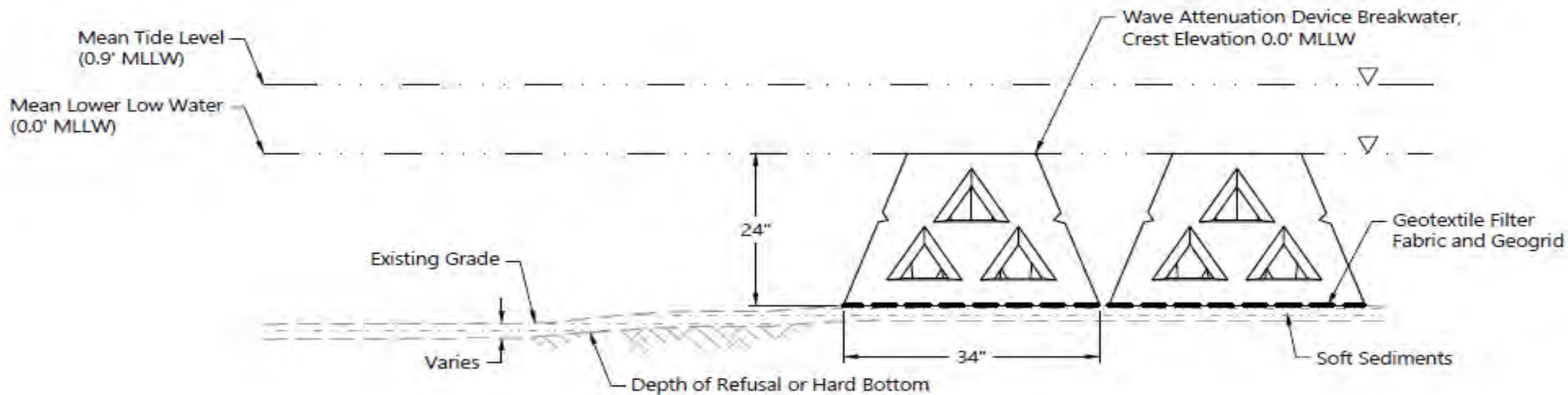

**Typical Section Wave Attenuation Device Breakwater**  
Not to Scale



# Project Description

continued

- **The applicant has requested a change to the Coastal Wetlands Use Plan in the footprint of the proposed project.**
- **This change request was justified under Miss. Admin. Code Title 22, Part 23 (MS Coastal Program), Chapter 7, Section 105.06.02**
  - **There is a significant public benefit in the activity**
  - **Impacts to public access and adverse environmental impacts have been minimized**
  - **The general public as well as governmental entities were notified of the project**
  - **A public hearing was held on October 17, 2019**

# Project Description

continued

- **The applicant has requested variances:**
  - **Miss. Admin. Code Title 22, Part 23 (MS Coastal Program), Chapter 8, Section 114.01**
    - **Permanent filling of Coastal Wetlands below the mean high tide line because of potential adverse and cumulative environmental impacts is not authorized.**
- **These variance requests were justified under Miss. Admin. Code Title 22, Part 23, Chapter 8, Section 118.01**
  - **The impacts on Coastal Wetlands would be no worse than if the guidelines were followed because the project meets several goals of the MCP**

# Public and Agency Notification

- Notification of this project appeared in *The Sun Herald* on August 11, August 18, August 25, September 22, September 29, and October 6, 2019.
  - Several public comments were received and a public hearing was held on October 17, 2019. Comments concerned:
    - Aesthetics
    - That alternatives have not been evaluated adequately
    - Maintenance and long-term survivability
    - Public involvement
    - The stated purpose and need
    - Secondary and cumulative impacts
    - That approval of the project would set a precedent
    - Impacts to nearby habitat and hydrology
    - Safety
- MDEQ: Issued 401 Water Quality Certification on February 25, 2020
- MDAH: Requested a cultural resources survey. After reviewing the survey, no objections
- MS SOS: The project will require a rent exempt lease
- MDWFP: No comments
- MDMR: No comments



# Recommendation

- **Based upon departmental review and evaluation based on the decision factors the MCP, it has been determined that the project will have a significant public benefit. Therefore, staff recommends the variance request and Use Plan change be approved and the requested permit be issued with the following conditions:**
  - **The project area should be re-checked for the presence of SAV during the growing season prior to implementation of the project.**
  - **The survey report should be submitted to MDMR Wetlands Permitting staff at least 30 days prior to project commencement**
  - **If SAV is found in the project area, a final review and approval by MDMR staff should be required prior to project commencement**

**Violation/After-the-Fact General Permit:  
Shawn Gollott  
File: DMR-190221**

- **Location: Back Bay of Biloxi, 3393 and 3387 Bay Shore Drive in D'Iberville, Harrison County, MS**
- **Use District: (G) General Use**



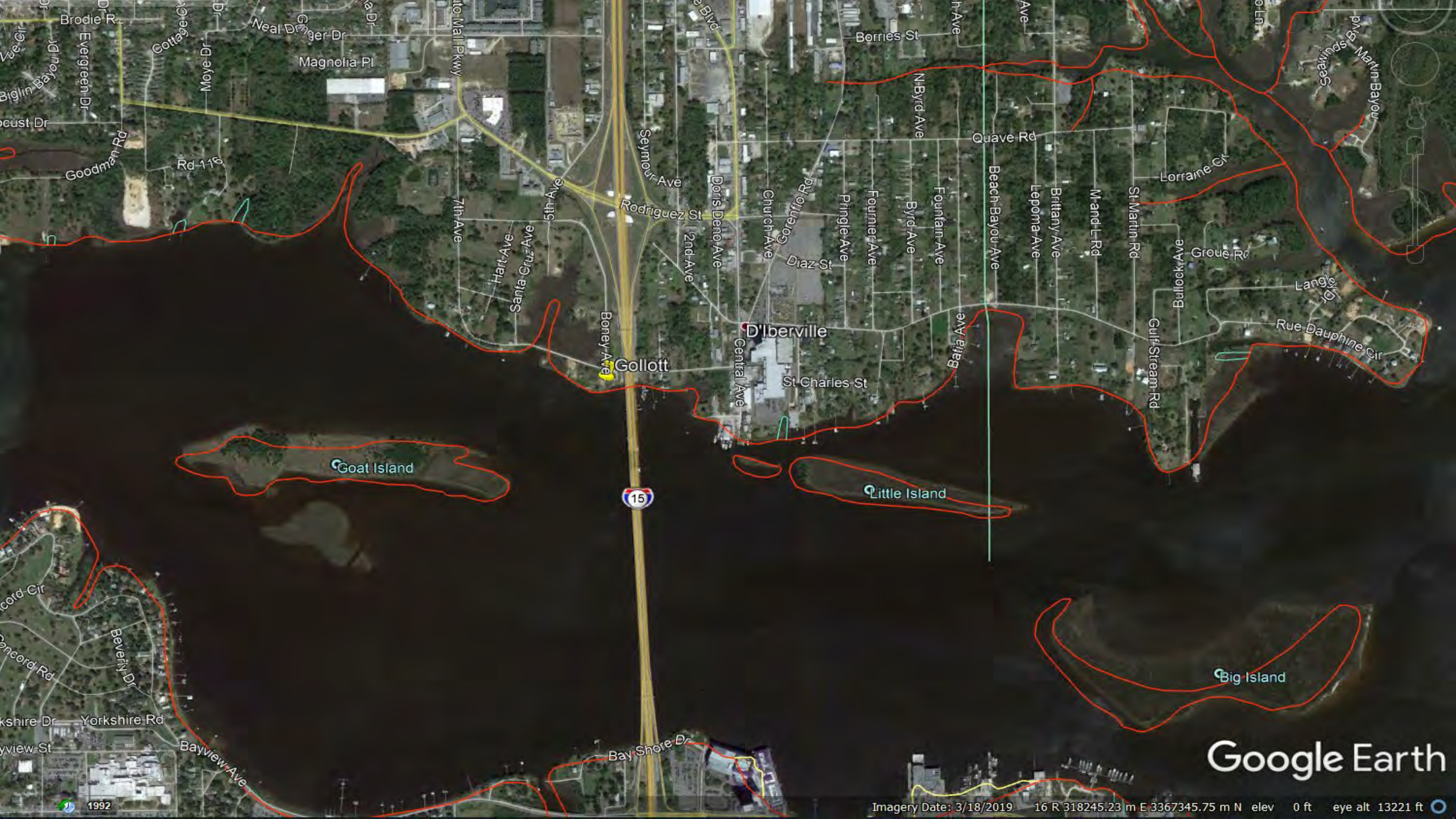

15

Goat Island

Little Island

Big Island

Gollott

D'iberville

Google Earth

Imagery Date: 3/18/2019 16 R 318245.23 m E 3367345.75 m N elev 0 ft eye alt 13221 ft

1992



# Project Description

- **Unauthorized riprap: 200'**
- **Proposed piers: 200' x 10'**

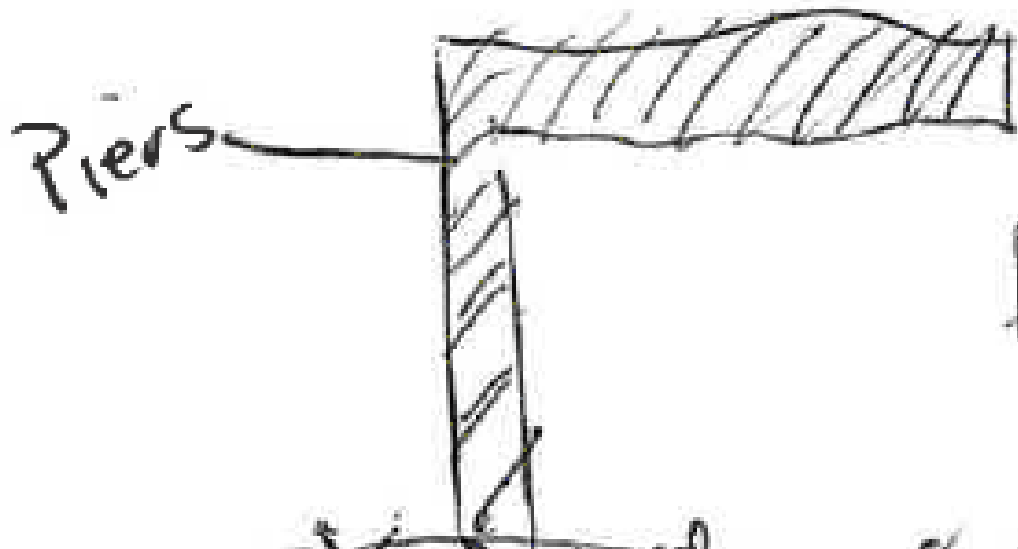

Piers

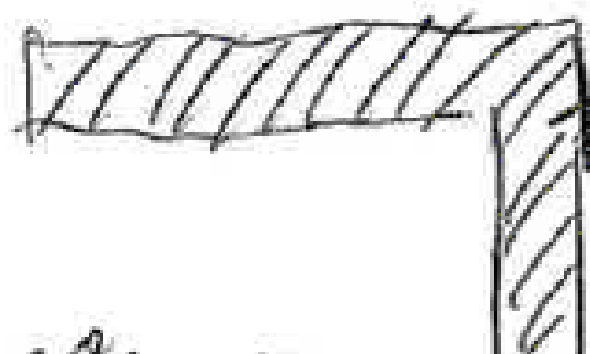

Piers

Boardwalk  
Decking



Run Road

3387  
Bay Shore  
Dr.

3393 2  
Bay Shore  
Dr.

# Project Chronology

- March 1, 2019: Incomplete General Permit application for construction of a bulkhead received
- March 12, 2019; April 2, 2019; April 10, 2019; April 26, 2019: Attempts to request commercial application fee
- May 8, 2019: 10- day response letter issued
- June 3, 2019: Application was denied without prejudice due to lack of information

# Project Chronology

- January 21, 2020: Violation discovered –
  - Placement of riprap without permit
  - Asphalt and rebar present in riprap
- January 22, 2020: Informed Mr. Gollott of Violation. Met on site and asked for the exposed rebar and asphalt to be removed, and an application for after-the-fact authorization to be submitted
- January 28, 2020: Notice of Violation issued
- February 21, 2020: Application for ATF authorization and fee received
- March 2020: Placed on Commission agenda, but meeting was cancelled, and it was decided that presentation should be delayed until Mr. Gollott could appear in person



# Potential Penalty Range

- **Violation discovered: January 22, 2020**
- **Violation duration: 47 days as of March 17, 2020**
- **Maximum potential fine for commercial: \$470,000.00 (\$10,000.00/day)**
- **Recommended Fine:**
  - **\$5,000.00**
- **Decision Factors:**
  - **Multiple attempts to complete original application**
  - **Riprap containing rebar and asphalt placed without a permit and after a letter of denial was issued.**
  - **As of March 17, 2020, the asphalt and rebar had not been removed as requested.**

# Recommendation

- The staff of the Department of Marine Resources has conducted an evaluation of the existing riprap. Because the placement of riprap was done without a permit and after the application had been denied, staff recommends:
  - A fine of \$5,000.00 in accordance with MS Code § 49-27-51
    - Should be paid within 45 days in accordance with MS Code § 49-15-415, or the matter should be forwarded to the Attorney General's office for further enforcement action (At the request of Mr. Gollott, a payment plan can be agreed upon to allow more time for payment)
  - Approval of the existing riprap
  - Approval of the proposed piers

**Violation/After-the-Fact Certificate of Waiver:  
Vivek Barclay  
File: DMR-040792**

- **Location: Bayou Porteaux, 14113 El Camino Real Road in Ocean Springs, Jackson County, MS**
- **Use District: (G) General Use**
- **Agents: Cleo Benward (Original General Permit) / Mike Arguelles (Current application)**



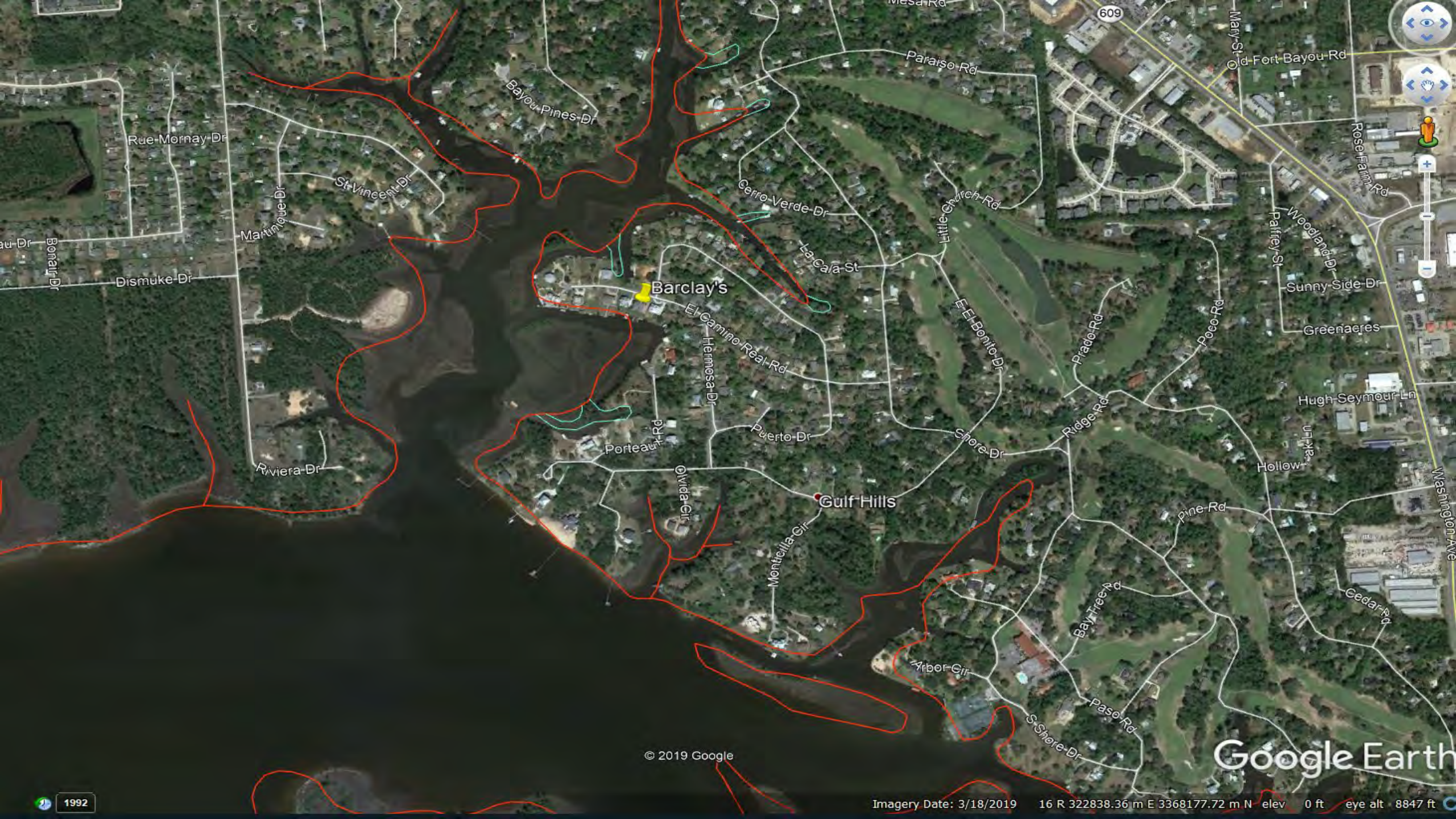

© 2019 Google

Google Earth

1992

Imagery Date: 3/18/2019 16 R 322838.36 m E 3368177.72 m N elev 0 ft eye alt 8847 ft



## Project Description

- **The applicant is requesting after-the-fact approval for existing boathouse, and approval for construction of a new boathouse.**

# Project Chronology

- May 24, 2016: General Permit application received without a diagram
- June 10, 2016: Diagram received, no dimensions listed on diagram. Agent notified; Revised diagram with dimensions received for a 32' x 20' boathouse
- June 16, 2016: Site visit revealed the proposed construction would exceed the allowed 25% into the waterway; Agent notified
- July 14, 2016: Received revised diagram of a 25' x 25' boathouse that fits within 25% of the width of waterway



# Project Chronology

- July 22, 2016: General Permit issued for construction of a 25' x 25' boathouse
- August 8, 2016: Agent submitted a request to modify the dimensions of the boathouse from 25' x 25', to 35' x 25'
- August 9, 2016: General Permit Modification issued
- October 1, 2019: Received new application for construction of a new boathouse

# Project Chronology

- October 24, 2019: Site visit conducted for new application
- October 24 – November 1, 2019: Researched existing structures and original permit; Existing structures found out-of-compliance with original permit
- November 1, 2019: Informed the acting agent and applicant of non-compliance issues:
  - Unauthorized access piers
  - Structure not constructed to permitted dimensions
  - Structure exceeds 25% of width of waterway

# Project Chronology

- January 16, 2020: Second site visit conducted to confirm measurements; Unauthorized access piers had been brought into compliance
- January 29, 2020: Application for after-the-fact authorization and final diagram received
- March 2020: Placed on Commission agenda, but meeting was cancelled, and it was decided that presentation should be delayed until the concerned parties could appear in person





Barclay's



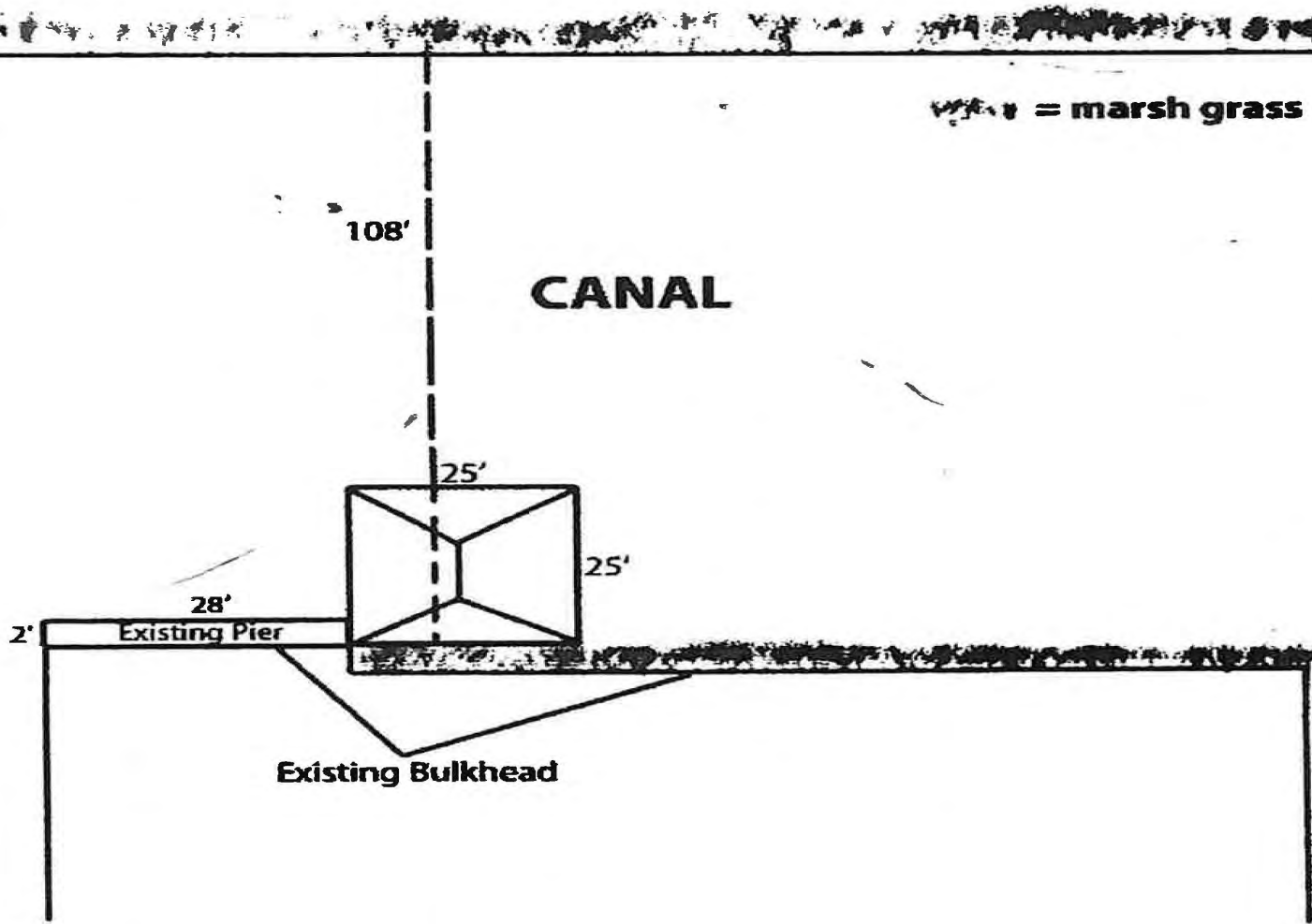

**DMR-040792**  
**Vivek Barclay**  
**14113 El Camino Real**

marsh grass

108'

CANAL

*Clearance*  
*8/8/14*

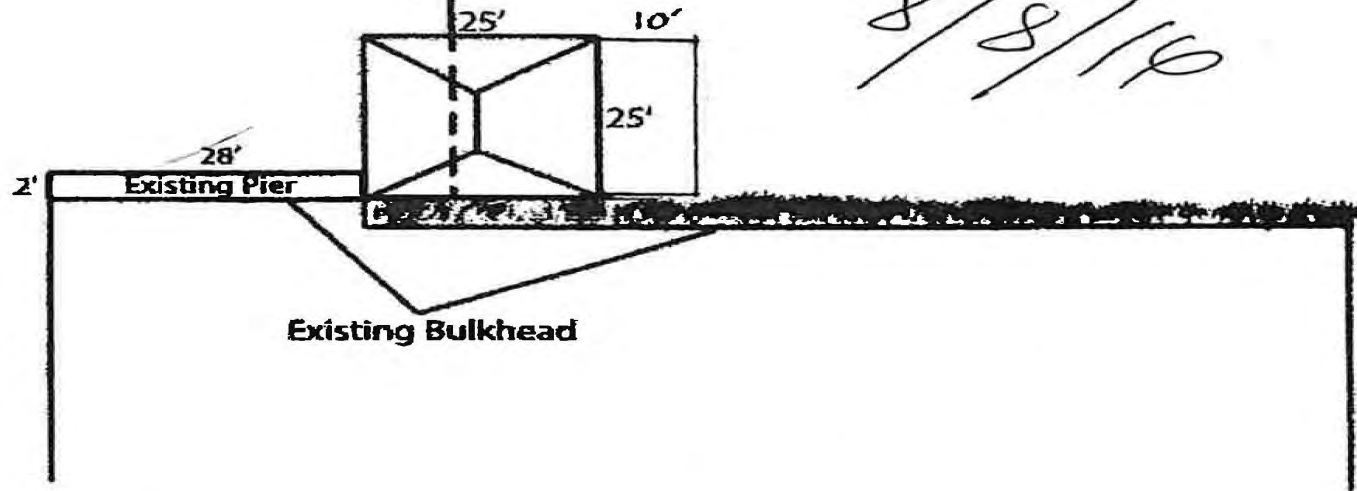

DMR-040792  
Vivek Barclay  
14113 El Camino Real



Directions to site: From I-10 Exit 50 South on Washington, West on Shore Dr into Gulf Hills (south entrance). Take a left on El Camino Real. Site is at 14113 El Camino Real the residence of Susan and Vick Barclay 282-2878 email Susan.barclay@mindspring.com Contractor - Mike Arguelles cell 424-8143.

Site Location  
14113 El Camino Real  
Ocean Springs (Gulf Hills)

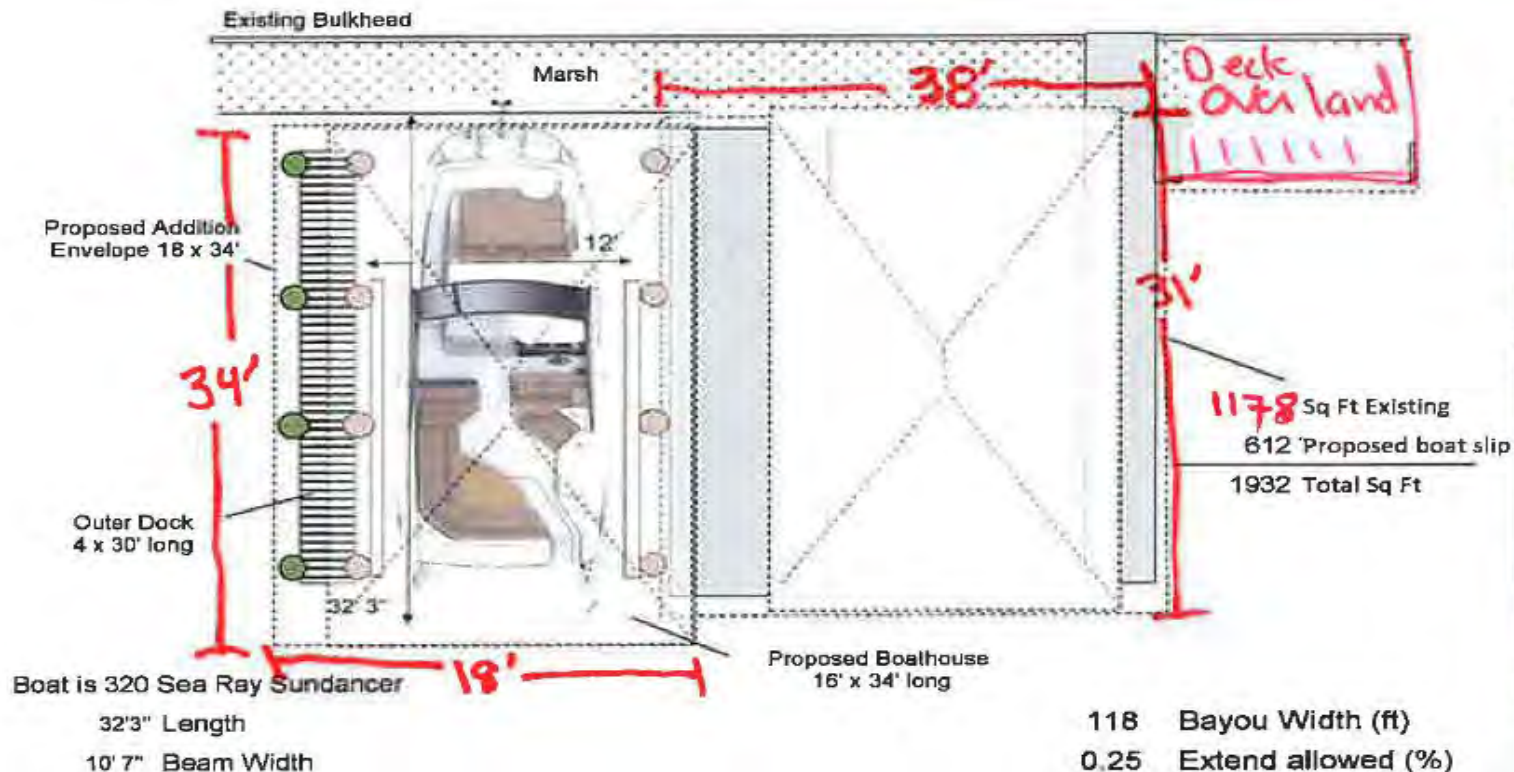

### Description of Work

- Build boathouse on 8 tall pilings using a track hoe on a barge
- Build an "island dock" along west side for boat maintenance
- Install a 20k boatlift in the boathouse

**Parcels: PORTEAUX BAY INC**

GISP	796.13-03-0126.03M
FIRST_ROUT	0126
FIRST_SUFF	03M
FIRST_SHAP	122,437.38
OID_	55,170
ID	55,171.00
PIDN	03613350.000
MAPNO	796.13-13-033.00
GISP_1	796.13-03-0126.03M
NAME	PORTEAUX BAY INC
NAME2	C/O ASCOT DEVELOPMENT CO INC
ADDRESS	1904 LAKELAND DR
CITY	JACKSON MS

[Zoom to](#) [Print](#)







Show search results for 14...



979,560.487 339,568.625 Feet



EL CAMINO REAL

PORTEAUX RD



## Potential Penalty Range

- **Violation discovered: November 1, 2019**
- **Violation duration: 1 day**
- **Maximum potential fine for residential: \$500.00**
- **Recommended Fine:**
  - **No fine recommended for property owner due to lack of knowledge**
  - **\$500.00 fine recommended for original General Permit agent**
- **Decision Factors:**
  - **Very familiar with the permitting process**
  - **Previous compliance issues**

# Recommendation

- The staff of the Department of Marine Resources has conducted an evaluation of the existing and proposed structures. Because the project would have been eligible for a Certificate of Waiver, staff recommends:
  - Approval for the boathouse as constructed
  - Approval for the newly proposed boathouse
  - No fine be issued to Mr. Barclay
  - A fine be issued to the original agent, Mr. Benward
    - Should be paid within 45 days in accordance with MS Code § 49-15-415, or the matter should be forwarded to the Attorney General's office for further enforcement action (At the request of Mr. Benward, a payment plan can be agreed upon to allow more time for payment)

**Request for Permits by:  
Jackson County Board of Supervisors  
File: DMR170270-1 and DMR170271-1**

- **Location: Catherine Roberts Bayou**
  - Near North Drive in Moss Point, Jackson County Mississippi
- **Dutch Bayou**
  - Near Dutch Bayou Road in Moss Point, Jackson County Mississippi
- **Use District: (G) General Use District**
- **Agent: Michael Baker International, Inc.**



# Project Description

- **Maintenance Dredging**
  - **Catherine Roberts Bayou:**
    - 3,180 feet in length, ranging in width from 5-30 feet to a depth of 6 feet MLW
    - 3,925 cubic yards of material
    - 0.52 acre of SAV
  - **Dutch Bayou:**
    - 7,555 in length, ranging in width from 5-30 feet to a depth of 6 feet MLW
    - 19,000 cubic yards of material
    - 1.38 acres of SAV
- ❖ **Disposal:** Sediment samples from the sites have been tested and reviewed by MDEQ. It was determined the dredged material is not suited for BU.
- ❖ The County is proposing to obligate funds to mitigate for the 1.90 acres of SAV impacts.



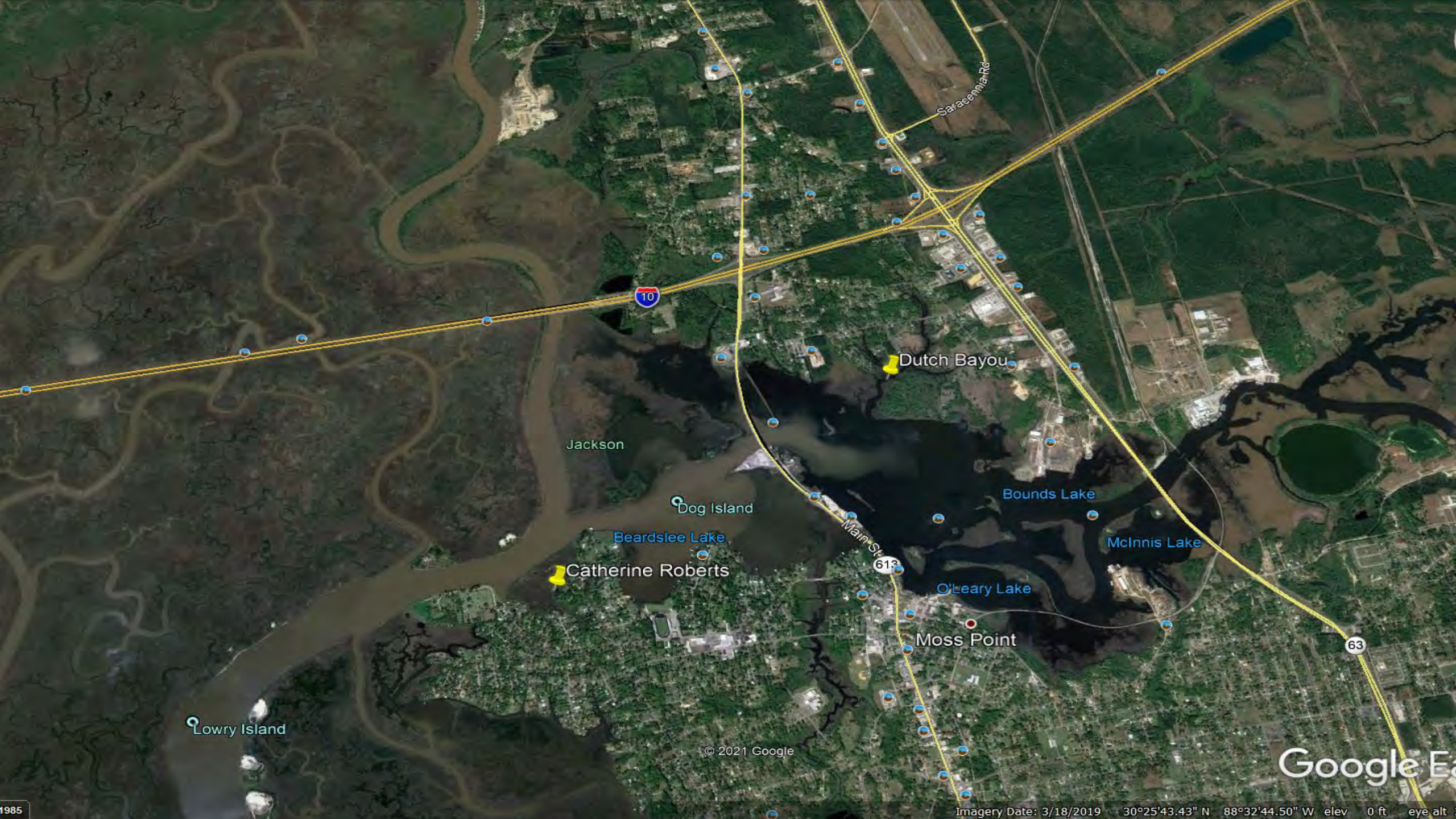

10

Saracenmia Rd

Dutch Bayou

Jackson

Dog Island

Beardslee Lake

Catherine Roberts

BOUNDS Lake

McInnis Lake

O'Leary Lake

Moss Point

Lowry Island

Main St  
613

63

© 2021 Google

Google Earth

Imagery Date: 3/18/2019 30°25'43.43" N 88°32'44.50" W elev 0 ft eye alt

1985



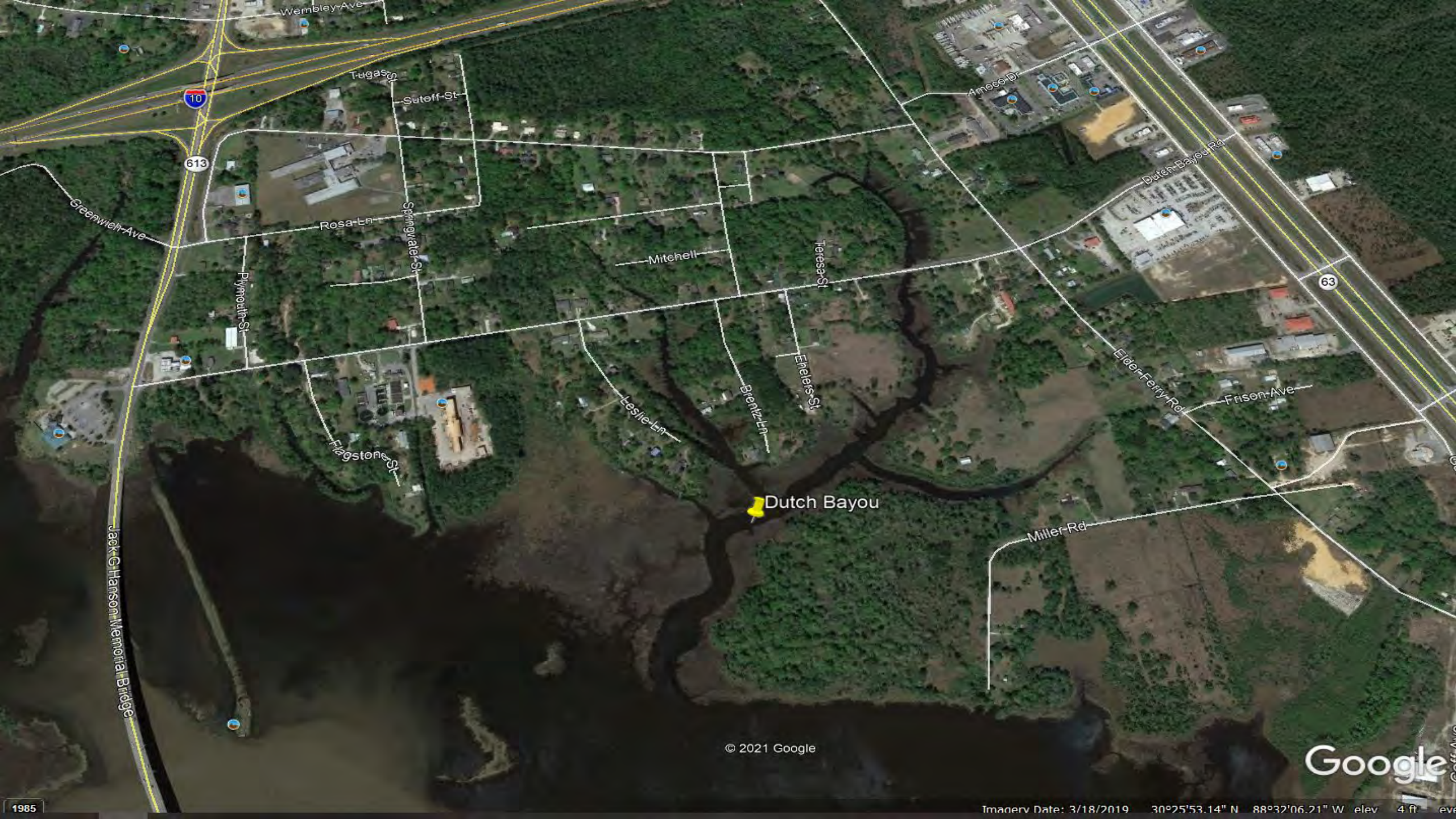

10

613

63

Dutch Bayou

© 2021 Google

Google

1985

Imagery Date: 3/18/2019 30°25'53.14" N 88°32'06.21" W elev 4 ft



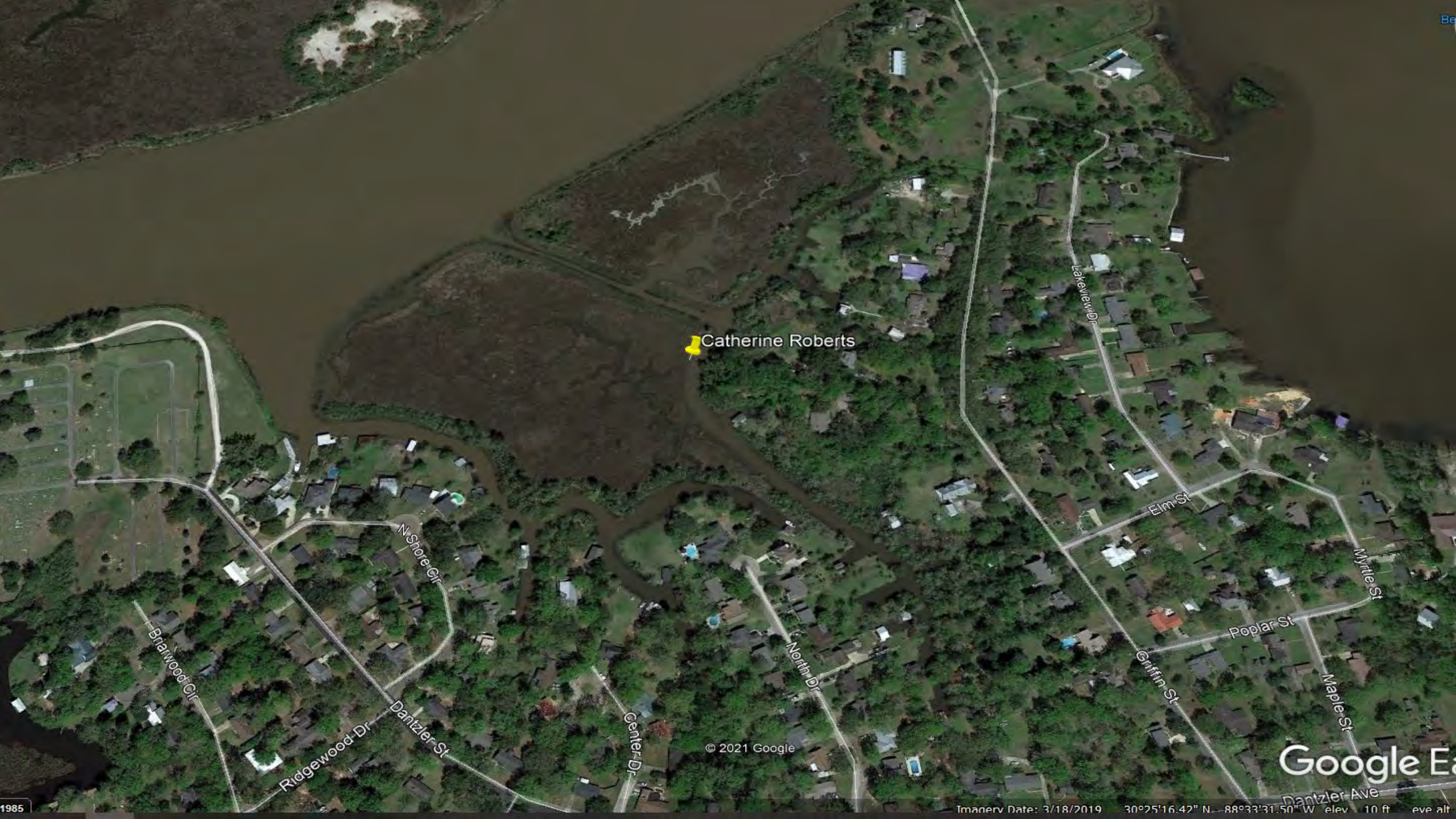

Catherine Roberts

© 2021 Google

Google Earth

1985

Imagery Date: 3/18/2019 30°25'16.42" N - 88°33'31.50" W elev. 10 ft eve alt

Briarwood Cir

Ridgewood Dr

Dantzler St

N Shore Cir

Center Dr

North Dr

Lakewood Dr

Elm St

Griffin St

Poplar St

Maple St

Myrtle St

Dantzler Ave





JACKSON COUNTY  
BOARD OF SUPERVISORS  
PASCAGOULA, MISSISSIPPI

**Michael Baker**  
INTERNATIONAL  
MICHAEL BAKER INTERNATIONAL  
CONSULTING ENGINEERS  
Ocean Springs, Mississippi

Designer:  
**PWF**  
Technician:  
**PWF**  
Checked by:  
**JDM**  
Project Number:  
**157052**

Notes:

REVISIONS			
No.	Description	Date	By

Project Name:  
**DUTCH BAYOU  
DREDGING PROJECT**

Drawing Name:  
**SITE LAYOUT  
SOUTHERN LIMITS**

Project Number:  
**157052**  
Date:  
**MARCH, 2017**  
Sheet Number:  
**1** of **2**  
Scale:  
**1" = 100'**  
Drawing Number:  
**LY-2**







Image courtesy of USGS Earthstar Geographics SIO © 2017 Microsoft Corporation



JACKSON COUNTY  
BOARD OF SUPERVISORS  
PASCAGOULA, MISSISSIPPI

**Michael Baker**  
INTERNATIONAL  
MICHAEL BAKER INTERNATIONAL  
CONSULTING ENGINEERS  
Ocean Springs, Mississippi



GRAPHIC BAR SCALE



One Inch = One Hundred Feet

Designer:  
**PWF**  
Technician:  
**DJM**  
Checked by:  
**JDM**  
Project Number:  
**157032**

Notes:

REVISIONS			
No.	Description	Date	By

Project Name:  
**DUTCH BAYOU  
DREDGING PROJECT**

Drawing Name:  
**SITE LAYOUT  
NORTHERN LIMITS**

Project Number:  
**157032**

Date: <b>MARCH 2017</b>	Sheet Number: <b>1</b> of <b>2</b>
Scale: <b>1"=100'</b>	Drawing Number: <b>LY-1</b>





**JACKSON COUNTY  
BOARD OF SUPERVISORS  
PASCAGOULA, MISSISSIPPI**

**Michael Baker**

**INTERNATIONAL  
MICHAEL BAKER INTERNATIONAL  
CONSULTING ENGINEERS  
Ocean Springs, Mississippi**

Designer:	
PWF	
Technician:	
PWF	
Checked by:	
JDM	
Project Number:	
157052	

Notes:

REVISIONS			
No.	Description	Date	By

Project Name:  
**CATHERINE ROBERTS BAYOU  
DREDGING PROJECT**

Drawing Name:  
**SITE LAYOUT**

Project Number:	<b>157052</b>
Date:	<b>MARCH, 2017</b>
Scale:	<b>T=50'</b>
Sheet Number:	<b>LY-1</b>
of	
Drawing Number:	

P:\Jackson County\157052 - JC Dredging\2. Design\2. Design\CAD\PLANS\Catherine Roberts Bayou\CATHERINE ROBERTS BAYOU Dredging Project.dwg - Jun 20, 2017 - 9:43am by Jack.Murphy



F:\Jackson County\157052 - JC Dredging\157052\157052\157052\CAD\PLANS\Catherine Roberts Bayou Dredging Project.dwg - Jun 20, 2017 - 9:46am by Donk.Wright

MATCHLINE STA. 20+00



**JACKSON COUNTY  
BOARD OF SUPERVISORS  
PASCAGOULA, MISSISSIPPI**

**Michael Baker**  
**INTERNATIONAL**  
MICHAEL BAKER INTERNATIONAL  
CONSULTING ENGINEERS  
Ocean Springs, Mississippi

Designer:  
**PWF**  
Technician:  
**PWF**  
Checked by:  
**JDM**  
Project Number:  
**157052**

Notes:

REVISIONS			
No.	Description	Date	By

Project Name:  
**CATHERINE ROBERTS BAYOU  
DREDGING PROJECT**

Drawing Name:  
**SITE LAYOUT**

Project Number: **157052**  
Date: **MARCH, 2017** Sheet Number:  of   
Scale: **T=50'** Drawing Number: **LY-1**



# Applicable Decision Factors

continued

- **c) Variance to the MS Coastal Program...**

- **Miss. Admin. Code, Title 22 Part 23, Ch. 08, Part 106.03**
  - “Alignments must avoid shellfish beds, areas of submerged and emergent vegetation, and archeological and historical sites.”
- **Miss. Admin. Code, Title 22 Part 23, Ch. 08, Part 117.01**
  - “Dredging or excavation of sensitive coastal wetlands is not authorized.”
- **Miss. Admin. Code, Title 22 Part 23, Ch. 08, Part 117.03**
  - “A minimum ten-foot (10-foot) buffer must be maintained between dredging/excavation and any wetlands.”
- **Justified under Miss. Admin. Code, Title 22 Part 23, Chapter 8, Parts 118.03 and 118.04**
  - “No feasible, alternative sites or construction techniques are available; there is a significant public benefit in the activity; a public hearing has been held; and the activity requires a waterfront location.”



# Applicable Decision Factors continued

- **d) Precedent setting effects...**
  - **Allowing dredging of significant amounts of submerged aquatic vegetation (SAV). The amounts of SAV impacted by these two projects have not been permitted before.**
    - JCBOS is a public entity
    - Avoidance and minimization to impacts has been done to the maximum extent practicable
    - SAV impacts are unavoidable to restore safe navigational depths
    - Both bayous are historically navigable channels
    - Storms and construction have caused the build-up of sediment
    - Jackson County did not previously have the money to maintain the channels

# Applicable Decision Factors continued

- **e) The extent to which the proposed activity affects biological integrity of coastal wetlands...**
  - Will not adversely affect the natural supply of sediments or nutrients, temperature or salinity regimes, water flow, or circulation
  - Will result in the destruction of 1.90 acres of SAV, which is essential fish habitat.
  - Sediments in these bayous are contaminated with dioxins and support few, if any aquatic species.
  - Booms should be placed around the active dredging sites until the disturbed sediments have settled.



# Applicable Decision Factors continued

- e) The extent to which the proposed activity affects biological integrity of coastal wetlands continued...
  - **Mitigation**
    - Ratio 9:1
    - Funding for management and removal of invasive aquatic species in Jackson County waterways
    - At least 17.10 acres of SAV habitat
    - 5 years
    - \$30,450.00 to MDMR's Coastal Preserves Bureau
    - Specifically planned for giant Salvinia management and removal
    - If current conditions of giant Salvinia change, funds can be used for other aquatic invasive species within the same waterways

# Applicable Decision Factors

continued

- **I) Comments...**
  - **Public Notice**
    - Notification of the projects appeared in the Sun Herald on May 3, 10, and 17, 2019 and March 21, 2021
    - Public Hearing was held March 30, 2021
      - No public comments were received
  - **MS DEQ: No comments**
  - **MS DAH: No objections**
  - **MS SOS: No objections**
  - **MS DWFP: Best Management Practices must be followed**

ENHANCE ★ PROTECT ★ CONSERVE



## Recommendation

- **Based upon departmental review and evaluation, staff recommends approval of the applicant's requests**
  - Dredging 22,925 cubic yards of material
  - Impacts to 1.90 acres of SAV
  - Mitigation at a 9:1 ratio which when calculated for a 5-year period equals \$30,450.00 to be used by MDMR's Coastal Preserves Bureau for the management and removal of giant Salvinia or other aquatic invasive species.
  - Three (3) variance requests
- With the condition booms should be placed around the active dredging sites until the disturbed sediments have settled.



ENHANCE ★ PROTECT ★ CONSERVE

# Mississippi Department of Marine Resources

Agency Financial Results  
as of March 31, 2021



Key Metrics:

- State Revenue of \$4.2M
- Agency Revenue of \$15.2M
- State Net Income of (\$424K)
- Agency Net Income of (\$2M)

**MISSISSIPPI DEPARTMENT OF MARINE RESOURCES**  
**Income Statement - Fiscal Year 2021**  
**As of March 31, 2021**

	Federal :		Operating		
	State	GOMESA PHII: NFWF:	Subtotal	Tidelands	Total DMR
<b>Revenue:</b>					
Transfer in from Other Governments	-	-	-	-	-
Off-road Fuel Tax	3,050,000	-	3,050,000	-	3,050,000
Federal/NonFederal Grants	-	2,516,505	2,516,505	-	2,516,505
Sales Revenue	724,167	-	724,167	-	724,167
Indirect Cost Recovery	358,142	-	358,142	-	358,142
Other Revenue	75,781	1,003,815	1,079,596	7,502,862	8,582,459
<b>Current Budget Year Revenue:</b>	<b>4,208,090</b>	<b>3,520,319</b>	<b>7,728,409</b>	<b>7,502,862</b>	<b>15,231,272</b>
<b>Expenditures:</b>					
Salaries, Wages, Fringe	3,881,860	2,170,581	6,052,441	700,697	6,753,138
Travel	6,767	-	6,767	-	6,767
Contractual Services	477,437	1,261,710	1,739,147	385,607	2,124,754
Commodities	241,778	175,050	416,828	21,378	438,206
Other than Equipment	-	-	-	-	-
Equipment	23,550	188,916	212,466	-	212,466
Vehicles	-	34,734	34,734	-	34,734
Wireless Devices	485	-	485	-	485
Subsidies, Loans, and Grants	1,098	4,153,330	4,154,428	3,538,260	7,692,688
<b>STATEXP</b>	<b>-</b>	<b>-</b>	<b>-</b>	<b>-</b>	<b>-</b>
<b>Current Budget Year Expenditures:</b>	<b>4,632,975</b>	<b>7,984,322</b>	<b>12,617,296</b>	<b>4,645,941</b>	<b>17,263,238</b>
<b>Current Budget Year Net Income/(Loss):</b>	<b>\$ (424,884)</b>	<b>\$ (4,464,002)</b>	<b>\$ (4,888,887)</b>	<b>\$ 2,856,921</b>	<b>\$ (2,031,966)</b>

# Financial Budget Comparison

- After nine months of Fiscal Year 2021:

**MISSISSIPPI DEPARTMENT OF MARINE RESOURCES**  
**2021 Budget Comparison**  
**As of March 31, 2021**

	<i>Actual Year to Date Expenditures</i>			<i>Budget Year Totals</i>			<i>Percent Remaining</i>		
	<b>Operating</b>	<b>Tidelands</b>	<b>Total</b>	<b>Operating</b>	<b>Tidelands</b>	<b>Total</b>	<b>Operating</b>	<b>Tidelands</b>	<b>Total</b>
<b>Expenditures:</b>									
Salaries, Wages, Fringe	\$ 6,052,441	\$ 700,697	\$ 6,753,138	\$ 11,141,304	\$ 1,259,291	\$ 12,400,595	45.7%	44.4%	45.5%
Travel	6,767	-	6,767	182,516	25,000	207,516	96.3%	100.0%	96.7%
Contractual Services	1,739,147	385,607	2,124,754	7,409,477	1,251,000	8,660,477	76.5%	69.2%	75.5%
Commodities	416,828	21,378	438,206	2,995,684	360,000	3,355,684	86.1%	94.1%	86.9%
Other than Equipment	-	-	-	-	40,000	40,000	0.0%	100.0%	100.0%
Equipment	212,466	-	212,466	537,669	35,000	572,669	60.5%	100.0%	62.9%
Vehicles	34,734	-	34,734	155,000	-	155,000	77.6%	0.0%	0.0%
Wireless Devices	485	-	485	3,750	-	3,750	87.1%	0.0%	87.1%
Subsidies, Loans, and Grants	4,154,428	3,538,260	7,692,688	30,108,057	6,378,986	36,487,043	86.2%	44.5%	78.9%
<b>Total Expenditures:</b>	<b>\$ 12,617,296</b>	<b>\$ 4,645,941</b>	<b>\$ 17,263,238</b>	<b>\$ 52,533,457</b>	<b>\$ 9,349,277</b>	<b>\$ 61,882,734</b>	<b>76.0%</b>	<b>50.3%</b>	<b>72.1%</b>

- Operating Funds have 76% of Budget remaining
- Tidelands Trust Fund has 50.3% of Budget remaining





ENHANCE ★ PROTECT ★ CONSERVE

# Mississippi's 2021 Recreational Red Snapper Season Update



Matt Hill  
April 20, 2021

K.1.

# Background

- 2021 will represent the second year of state management under Reef Fish Amendment 50
- Reef Fish Amendment 50 – State Management of Recreational Red Snapper
  - Gives authority to each gulf state to manage the Red Snapper fishery out to 200 nautical miles
  - Each state receives allotment of the overall Recreational Red Snapper quota
  - Mississippi's current allocation is 3.55%



# 2021 Red Snapper Season

- Currently, Mississippi's 2021 ACL will be approximately 120,000-150,000 lbs.
- The 2021 recreational season will begin the Friday of Memorial Day Weekend (May 28<sup>th</sup>) and close Monday, July 5 at midnight. The season will close before this date if the ACT is met.
- MDMR staff will analyze landings throughout the season to develop recommendations providing anglers the most opportunity and greatest flexibility for Red Snapper harvest.

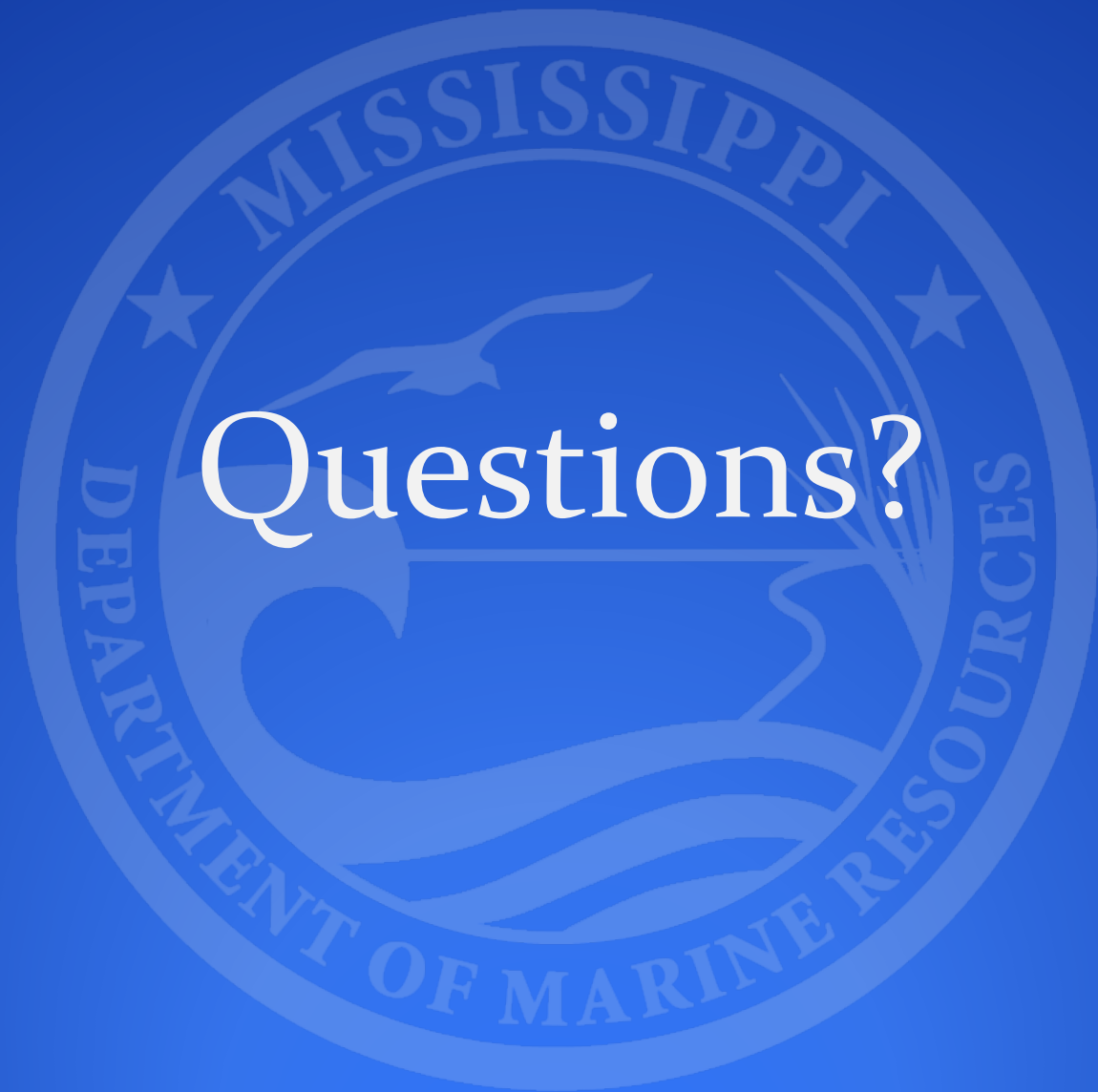

Questions?

ENHANCE ★ PROTECT ★ CONSERVE