

# Kentucky 4-H Entomology

## Guide to Insect Collecting and State Fair Projects

### **Objectives:**

The objectives of 4-H Entomology Insect Collecting Projects are to:

- Discover the value of making an insect collection.
- Learn how to collect, label, and display insect specimens.

### **Making an Insect Collection**

Making a collection is the best way to learn about what insects look like, where they live, and what they do. A collection also helps you tell other people what you have learned about insects.

Your collection for your first project will be relatively small - only 25 different insects. The only limits are that the collection must contain insects from at least 4 different orders and no more than 10 insects in the same order. This means searching different places to find a variety of insects. To get insects for your collection, you will have to find them, capture them, kill them, pin them, and make labels for them. As you move to your second year, third year, and beyond, you will add more and more insects for your collection using the same techniques that you learn while making your first-year project.

### **Where and How to Collect Insects**

Insects can be found almost anywhere, including:

- In the air.
- On a wide variety of vegetation, both day and night.
- Around street lights, porch lights, and study lamps.
- In woodpiles, especially in spring and early summer.
- In the soil.
- In fresh or decaying fruit.
- On domestic animals (e.g. as fleas and lice).
- Along the edges of rivers, streams, lakes, or ponds and in the water.
- In buildings: windows, flour bins, cereal packages, closets, or boxes where clothing and old papers are stored.

As you can see, insects live in all kinds of places. Some are a real challenge to capture, while others move and can be picked up by hand and put directly into a collecting jar. If you think an insect may bite or sting, gently tap it into your jar with a twig, or use tweezers to pick it up.

You will need an insect net to catch fast-moving insects. An insect net can be used in a variety of ways. You can use it to scoop insects out of the air as they fly past, or you can sweep the net through weeds and flowers to catch whatever is hidden within. Some insects "play possum" when disturbed. To catch them, hold your net under plants and shake the insects off into the net.

Be very careful when catching stinging or biting insects. Try this technique: sweep the insect into the net and, with a quick jerk, force it to the bottom of the bag. Then grasp one hand around the bag just above the captured insect. Put the end of the bag with the insect into your collecting jar. Place the jar lid over the mouth of the jar as tightly as you can, and wait until the insect becomes still. Then take the end of the bag out of the collecting jar, quickly remove the stunned insect, and put it back into the collecting jar.

Collecting moths and butterflies without damaging them requires special care. To keep these insects from escaping after being netted, whip the net so the insect goes to the bottom of the bag. Keep the insect trapped in the bag by giving the net a flip so the bag bottom rests across the loop. Then pinch the thorax of the insect while it is still in the net. This will stun the moth or butterfly and keep it from beating the scales off its wings when it is put in the collecting jar.

## Making a Killing Jar

You will need to kill the live insects you capture before putting them into your collection. The killing method should be quick and as painless as possible. Also, the killing method should not ruin the insect's appearance. A killing jar that can be carried with you is handy for doing this.

Any clear, wide-mouthed, plastic jar with a tight screw-cap lid can be used to make a killing jar. A pint-size jar (a peanut butter jar works well) is easy to carry and will be big enough to hold large insects. You can make larger or smaller killing jars to suit yourself.

After selecting a jar, cut discs of blotter or newspaper to fit snugly into the bottom of the jar. A stack of discs 1/2-inch high is enough.

When you want to use the killing jar, pour fingernail polish remover or rubbing alcohol onto the paper discs. Pour off any fluid that is not absorbed by the paper. Then put a few narrow strips of tissue paper in the jar. The tissue paper helps absorb moisture and gives the insects a place to hide. When insects are hiding, they do not thrash around and damage themselves so much.

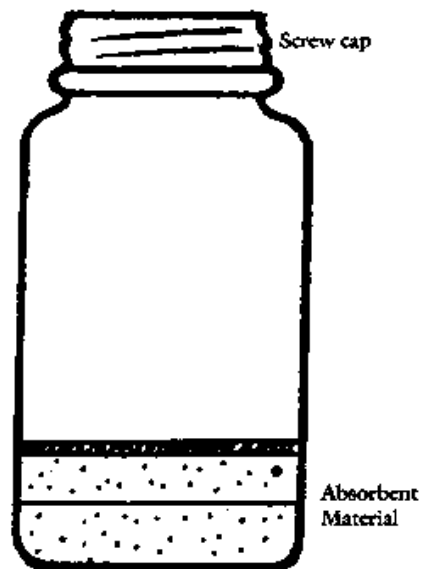

Killing jars containing cyanide, carbon tetrachloride, gasoline, or ether are too dangerous to be used safely. Even though fingernail polish remover is relatively safe, the killing jar should be labeled **KILLING JAR--POISON**.

After any insect is killed, **DO NOT** leave it out in the open for very long, or it will become too brittle to mount on an insect pin. It is best to pin insects on the same day that they are captured. If this isn't possible, store insects in a freezer until you are ready to pin them. But do not leave the insects in the freezer for more than a month: this will also cause them to become brittle.

## **Freezing Insects**

Another way to kill insects is to freeze them. If you want to freeze your insects, start by placing the insects in small containers as you collect them. Many things can function as a container, including baby-food jars, old spice bottles, and even zip-lock bags. It is a good idea to carry both large and small containers. Preferably, put only one insect in each container, so that the insects will not harm one another. When you are finished collecting, put the containers in the freezer for at least 3 hours. The insects can then be removed and are ready for pinning after a few minutes.

This method is less messy and cheaper than using a killing jar. The only drawback, other than waiting overnight for the insects to freeze, is that you often have to carry several small containers while you collect instead of just one killing jar.

## **Pinning Your Insects**

After you have finished collecting for the day, it is wise to go ahead and prepare the specimens to put in your collection. This means putting them on insect pins. Don't wait until the next day, because the insects may become dry and brittle, and parts of the insect may break off when you try to pin them.

You can begin pinning the insects after they have been in the killing jar for about 20 minutes. If you take them out of the killing jar too soon they may revive after you have pinned them.

Use special insect pins that can be bought through your county Extension agent or 4-H project leader. Gently run the pin through the thorax of the insect a little to the right of the midline of the body. The following illustration shows examples of the correct spot to insert the pin. Leave about 1/4-inch of the pin visible above the specimen. This will be enough of a handle to pick up the specimen without touching the insect. There will be enough room on the pin below the insect to add labels. Work carefully and try to get the insect level on the pin so it is not tipped from front to back or from side to side.

To properly pin butterflies and moths, follow these additional steps. Once the insect is pinned through the body, position the wings as shown with a spreading board (purchased from a supply store) or with two blocks of Styrofoam<sup>TM</sup>, each twice as long as the butterfly or moth and about

the same height as the insect on the pin, placed on either side of the insect. The wings should be gently pulled into place with an insect pin placed behind a large wing vein. The back margins of the front wings should be perpendicular to the insect's body, with just a slight notch between the front and back wings. Narrow strips of paper placed over the wings will hold the wings in place (the strips of paper should be pinned to the spreading board as well). Depending on the moisture in the air, it may take up to a week for the wings to completely dry in place.

Examples of correct pinning methods for common insects:

1. Pin bees, wasps, flies, dragonflies and other insects with similar wings through the thorax between the bases of the wings.

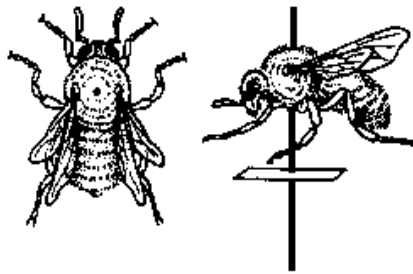

2. Pin true bugs through the right corner of the "scutellum." The scutellum is a triangular area with the point of the triangle pointing to the rear. In stink bugs the scutellum is large, but in other bugs it may be quite small.

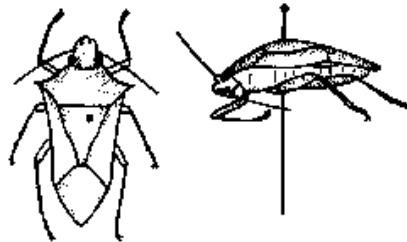

3. Pin beetles to the right of the center line so that the pin emerges from the underside of the insect between the middle and hind legs of the right side. Do not pin so far back that the pin comes through the abdomen.

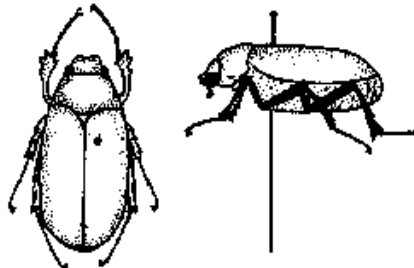

- Pin grasshoppers so that the pin emerges between the middle and hind legs of the right side. Insert the pin near the right hind margin of the “pronotum.” The pronotum is the saddle-shaped structure of the thorax just behind the head.

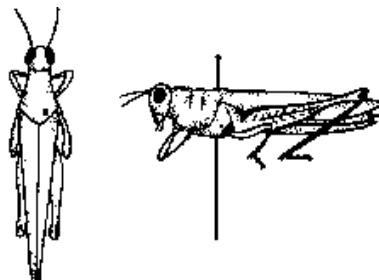

The illustrations below show some correctly and incorrectly pinned insects.

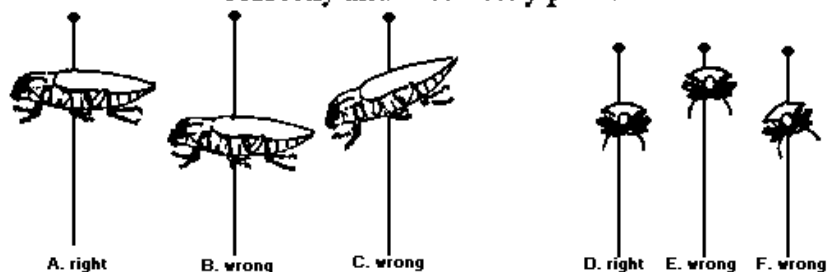

Illustrations of right & wrong methods of pinning:

A. correct height & position for specimen  
 B. insect too low on the pin  
 C. insect tilted on pin

D. correct height & position for specimen  
 E. insect too high on the pin  
 F. insect tilted on the pin

## How to Card Point Small Insects

Small, delicate insects may be impossible to pin in the conventional way with standard sized insect pins. You can solve this problem by using the card point pinning technique explained below. Prepare several card points on pins in advance so they are ready when you want to mount a small insect.

- Select some heavy paper, such as a file card, and cut triangular card points to the dimensions as shown in Figure A.
- Put an insect pin through the base of the card point. Use a pinning block as shown in Figure B to position the card point on the pin.
- With a pair of tweezers, bend down the tip of the card point as shown in Figure C.
- Put a tiny drop of glue on the bent down tip of the card point, and touch the glue drop to the right side of the insect as shown in Figure D. Do not use so much glue that the insect

becomes totally embedded in it. When you lift up the pin, the insect should be level and topside up as shown in Figure E.

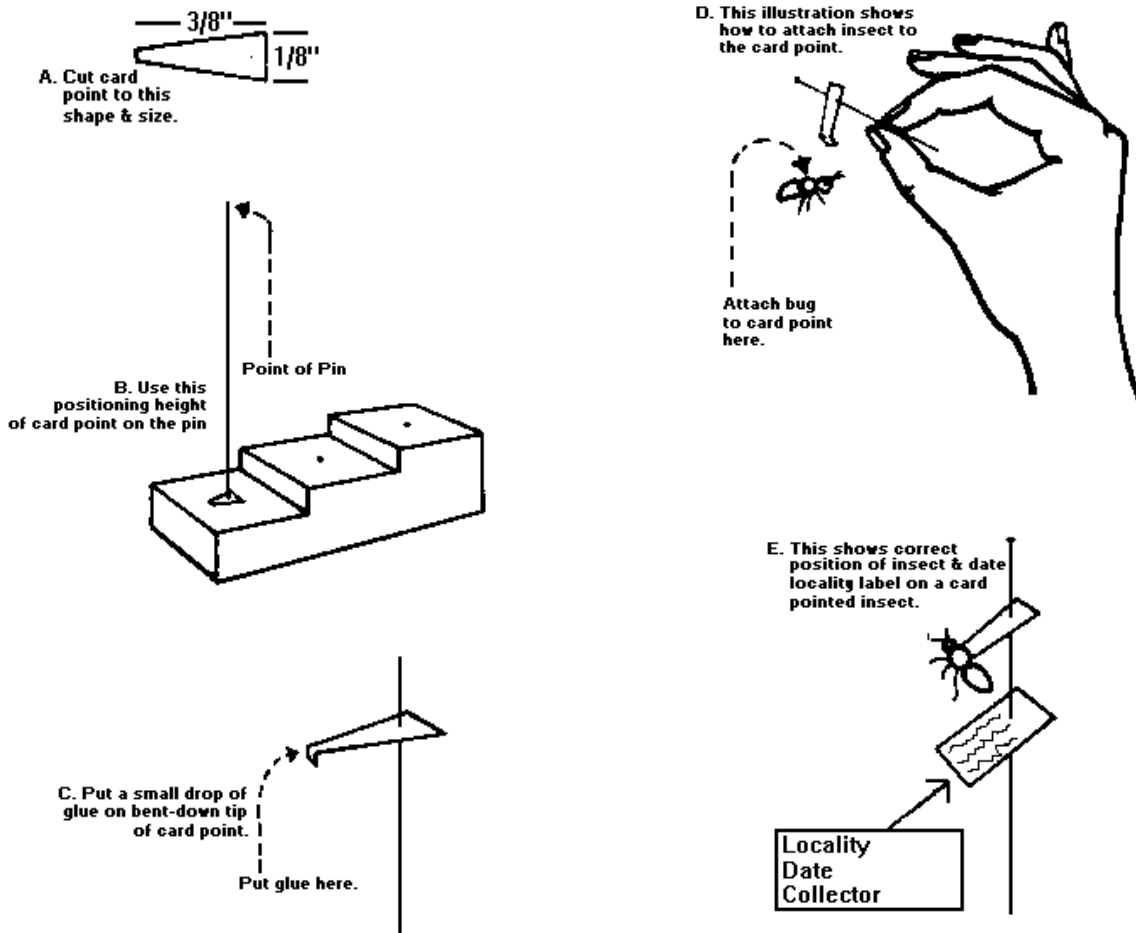

## Spreading Butterflies

Moths and butterflies look better and are easier to identify if their wings are spread properly. A spreading board is used to do this. Adjustable spreading boards for use with different sized butterflies can be bought from biological supply houses. The slots in the cover of the styrofoam box you might have bought for 4-H Entomology Project 1 can also be used for spreading. (If you don't have either of these, you can make a spreading board, using these instructions on the U.K. Entomology website: [www.uky.edu/Agriculture/Entomology/ythfacts/4h/unit2/hotmsb.htm](http://www.uky.edu/Agriculture/Entomology/ythfacts/4h/unit2/hotmsb.htm))

1. Put an insect pin through the center of the thorax of a freshly killed butterfly.



2. Push the pin straight down in the center of the slot of your pinning board until the outstretched wings are just level with the surface of the pinning board.

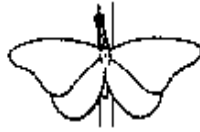

3. Insert an insect pin lightly in each front wing near the front margin and just behind one of the heavy wing veins. Move the front wings forward gently until the hind margins of the front wings are in a straight line, at right angles to the body.

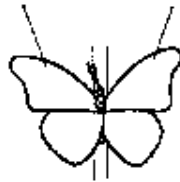

4. With a pin placed behind a heavy vein in the hind wing, move each hind wing forward until the gap between the front wing and hind wing is closed to just a notch, as shown on the right side of the illustration below.

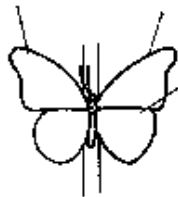

5. Cut narrow strips of thick wax paper and lay them over the wings. Pin them in place as shown. Remove the other pins that are through the wings. The pins holding the paper strips in place should not go through the wings but should be close to them to keep enough pressure on the wings to prevent their slipping out of place. If the abdomen tends to sag, it can be propped up with pins until it dries. You can also use pins to keep the antennae in place while the specimen dries. Depending on the moisture in the air, the specimen should remain on the board from up to eight days.

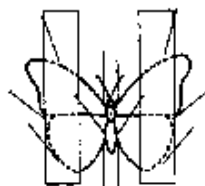

## Labeling Your Insects

After you have pinned an insect, make out a date-locality-collector label to put with the insect. You can get blank labels, which are printed on cardboard, from your 4-H project leader or county Extension agent. The example below shows you how the labels are to be filled out. If the insect was not collected in Kentucky, use the back of a printed label to record the date-locality-collector information.

Fayette			Co.
KY.	21	Jun	19
Coll.	John Doe		

<b>COMMON NAME</b>
<i>Ladybird Beetle</i>

Use a fine-pointed pen, called a crow quill pen, and India ink to fill in the labels. Ball-point pens and pencils are too coarse or smeary to do a neat job, but a micro-point roller ball pen is acceptable.

It is usually a good idea to fill in a label while it is still attached to the label sheet. If you cut the label out first, it is harder to hold in place while you write on it because it is so small.

After you have completed a label and cut it out, attach it to the pinned insect. The dot at the center of the label shows where the insect pin is inserted. Line the label up so it is parallel to the insect's body and can be read from the left side of the insect. Lining up the date-locality-collector label in this way better protects the insect from damage and also takes up less space. It will also allow the "Common Name" label to be read more easily when it is put on the pin.

## Identifying Your Insects

Identifying insects can be a real challenge, but it is also fun. There are several ways to figure out what kind of insect you have:

- Matching your insects with pictures in books. Handbook of the Insect World, available as part of the entomology project, contains many pictures of common insects.
- If you can't find a picture to match an insect you have, you can use a key to identify it. An insect "key" is a step-by-step system which leads you to the proper identification of an insect. The **Key to the Orders of Insects** at the end of this publication will help you identify orders of insects, and also has descriptions of the insect orders to supplement the information in the key.
- There are also many excellent field guides available at book stores and on the Internet that can help with identification. Some are listed below:

**Borror, D.J. and R.E. White. A Field Guide to the Insects. Boston: Houghton Mifflin Co.**

**Covell, C.V. Peterson Field Guide to Eastern Moths. Boston: Houghton Mifflin Co.**

**Dunkle, S.W. Dragonflies of the Florida Peninsula, Bermuda, and the Bahamas.**

**Gainesville, FL: Scientific Publishers.**



**Farrand, J., Jr. The Audubon Society Pocket Guide to Familiar Insects and Spiders. New York: Knopf.**

**Feltwell, J. Butterflies of North America. New York: Smithmark Publishers.**

**Klots, A.B. A Field Guide to Butterflies. Boston: Houghton Mifflin Co.**

**Milne, L. and M. Milne. Audubon Society Pocket Guide to North American Insects and Spiders. New York: Knopf.**

**Walton, R.K. The Audubon Society Pocket Guide to Familiar Butterflies of North America. New York: Knopf.**

**White, R.E. Peterson Field Guide to Beetles. Boston: Houghton Mifflin Co.**

## **Storing and Displaying Your Collection**

After you have pinned and labeled your insects, keep them in a safe place (such as a cigar box, covered shoe box, or insect box from a hobby store) where they will not get broken or eaten by carpet beetles. Placing moth balls in the insect boxes will also help repel carpet beetles. For instructions on how to build your own storage box, check the U.K. entomology website at <http://www.uky.edu/Agriculture/Entomology/ythfacts/4h/unit1/optact.htm>.

If you enter your collection in the display competition at fairs, you will have to use a regulation display box. A cardboard display box acceptable for exhibiting at fairs can be purchased by writing to:

Entomology Department  
S-225 Agricultural Science Building, North  
University of Kentucky  
Lexington, KY 40546-0091.

Your 4-H project leader or county Extension agent can tell you the price. Checks for these boxes should be made payable to "Friends of Kentucky 4-H."

## **Getting More Variety in Your Collection**

If you collect in only a few different places during the day and use the same collecting techniques, it may be hard to find enough variety of the insects you want for your collection. Many types of insects that cannot be found during the day are attracted to lights at night. Some insects will come to lights early in the evening, and others may come very late. The color of the light also affects the attraction of insects. A black light (ultraviolet) is more attractive to a greater variety of insects than lights of other types. You can also devise traps to collect insects when you are not at the light.

# St. Fair Collection Guidelines

## Preparing Your Collection for St. Fair Exhibition: Projects 1-4

1. All exhibits are to be in standard size boxes: 18" x 24" and not more than 3 1/2 " thick with a plexiglass cover and cellotex-type false pinning bottoms. Entomology boxes ordered through the State 4-H office as indicated in "Storing and Displaying Your Collection" are also be acceptable.
2. Specimens are to be arranged so the box can be exhibited horizontally.
3. Identification labels available from your county Extension office must be used. Follow instructions for pinning and labeling included in this Unit.
4. Use insect pins for pinning insects.
5. Use the 4-H Entomology identification labels.
6. Include a "collection catalog" in an envelope attached to the back of the display box. The catalog should list each insect, its order and common name. Space should be left next to each listing for judge's comments.
7. Insect identifications should be consistent with Kentucky 4H materials.

### Project 1 Guidelines:

The first-year project consists of one box (up to a maximum of 2 boxes) with a minimum of 25 insects from at least four orders. Up to 50 insects may be included. Identification beyond the order is not necessary, but correct "common names" will yield a higher score. All specimens must have the date-locality label.

### Project 2 Guidelines:

For second-year 4-H insect collections, the display should consist of one box with a minimum of eight orders and not less than 50 insects. Up to 2 boxes and 100 insects may be included. At least one-half of the insects must include common names. Do not exceed the minimum requirements to the extent that insects are jammed in a messy way in the box. If you have a lot of insects, it is best to choose only the best specimens to make a nice-looking, uncluttered display.

### Project 3 Guidelines:

Third-year 4-H insect collections should include 2 boxes with a minimum of 10 orders and 100 insects, up to a maximum of 150 insects. All insects must include common names.

### Project 4 Guidelines:

Fourth-year 4-H insect collections should consist of 2 boxes with a minimum of 12 orders and 150 insects, up to a maximum of 250 insects. A third box must be included which focuses on a pest insect. This pest display box should contain an example of the insect

damage, the stage of the insect causing the damage, and any other stages of the insect that is important for diagnosing the problem. Include information in the display that tells how the insect is managed. All insects must include common names.

### **Project 5 Guidelines:**

Fifth-year 4-H entomology projects may consist of any display which pertains to experiences beyond those of previous projects. Examples include: special collections of native or exotic insects, an in-depth study of one insect or small group of insects, or a collection of immature insects. Charts, photographs, models, or other visual aids may be used. 4-Hers are encouraged to write a short (less than 200 words) statement regarding the theme of their fifth-year display. Fifth-year projects may be repeated for successive years, but it must be a different exhibit each year. No exhibit that has been judged in any previous State Fair may be entered.

### **Tips for Improving Your Display Collection**

There are certain specifications on which your insect collection will be judged in competition. The information below will help you in preparing your display.

1. Insects must be arranged in the box so that the short sides of the box are the right and left. Insects must be in vertical columns with the head of each insect toward the front (top) of the box.
2. Insects on card points must be pointed in the same direction as the other insects, with the card point jutting to the left from the pin.
3. All insects of the same order must be grouped together into one series, but they may continue into more than one column. In other words, insects in the same order should not be scattered in the box and separated from each other by insects of other orders.
4. The largest insect of an order must be placed first in that order series; the rest should be placed according to decreasing size.
5. Common names must be more precise than the common name of the order. For instance, "beetles" is the common name for Order Coleoptera, so when identifying a beetle you should try to identify what kind it is, such as Colorado potato beetle.
6. See that the order labels lie flat on the bottom of the box in front of the first insect in the order series. It should be held in place with two common straight pins. If the series continues into the next column, label the continued column also. If an order series ends in the middle of a column, you may start the next order series right after it.
7. A "date-locality" label must be on the pin of each specimen. The pin should go through the dot at the center of the label. The label should be aligned parallel to the insect's body so it can be read from the left side of the collection. Keep the labels at a uniform height on the pins.
8. If the wing length of moths or butterflies is one inch or more, the wings should be spread.

9. The "common name" labels rest on the bottom of the box and are held in place by the specimen pins. The pin should go through the dot on the right side of the label, causing the label to jut to the left from the pin. If the insect is large and blocks the view of the common name label, the label may be placed on a separate pin close after the insect. Every insect should have a common name label whether anything is written on it or not.
10. Every insect in the collection should be different, either a different species or a different form of the same species. (Males and females of the same species often look slightly different, so you can use a male and a female as different insects.)
11. Damaged or poorly pinned insects detract from the appearance of your collection and will count against your display score. Replace such specimens if you can. However, if a damaged insect is your only representative of that order, or if you need the insect to meet the minimum number of insects, then you should include it in your display collection.
12. When entering your display in competition at fairs, be sure to attach a collection catalog to the display box. The catalog will make it easier for the judge to make constructive comments. Points are given for having a catalog with the collection.
13. A more diverse insect collection will be awarded more points. Try to find more than the minimum number of orders and specimens.