

SOUNDTOXINS MANUAL

Puget Sound Harmful Algal Bloom
Monitoring Program



Revision of this manual was funded in part by the United States Environmental Protection Agency through its National Estuary Program via Contract G1300035, with the Washington Department of Ecology serving as Lead Organization for Toxics and Nutrients Prevention, Reduction, and Control projects, and by a NOAA Sea Grant Aquaculture Extension and Technology Transfer grant (NA13OAR4170202).

For citation purposes:

SoundToxins manual (2016) Washington Sea Grant, 36 p.

WSG-AS 15-04
Revised December 2015

NOAA/NMFS/NWFSC Marine Biotoxins Program

2725 Montlake Blvd E, Seattle, WA 98112

Vera Trainer

Program Director

T: 206.860.6788

vera.l.trainer@noaa.gov

Teri King

Program Coordinator

T: 360.432.3054

soundtox@uw.edu

Washington Sea Grant

PO Box 488, Shelton, WA 98548

Brian Bill

Science Coordinator

Phytoplankton ID

T: 206.860.3387

brian.d.bill@noaa.gov

Jennifer Runyan

*Data Manager/
Program Coordinator*

T: 360.432.3054

soundtox@uw.edu

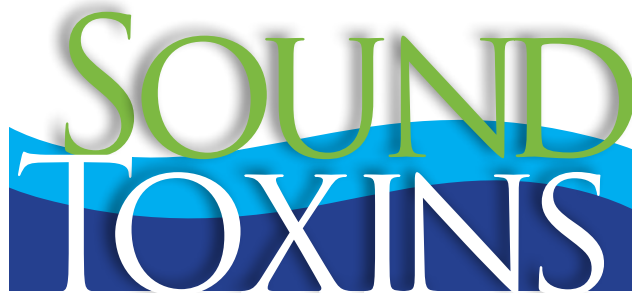

Washington Sea Grant
University of Washington
3716 Brooklyn Ave. N.E.
Box 355060
Seattle, WA 98105-6716

206.543.6600

wsg.washington.edu

seagrant@uw.edu

Contents

SoundToxins Overview.....	1
A Brief Introduction to Marine Phytoplankton.....	3
Definition.....	3
Features.....	3
Kinds of Organisms.....	3
1. Diatoms.....	3
2. Dinoflagellates.....	5
3. Flagellates.....	8
References.....	8
Phytoplankton Identification.....	10
Species Specific Identification Sheets.....	11
1. Diatoms.....	11
<i>Chaetoceros concavicornis</i>	11
<i>Pseudo-nitzschia</i> spp.....	12
2. Dinoflagellates.....	14
<i>Alexandrium</i> spp.....	14
<i>Dinophysis</i> spp.....	15
<i>Gonyaulax spinifera</i>	16
<i>Protoceratium reticulatum</i>	17
<i>Scrippsiella trochoidea</i>	18
3. Flagellates.....	19
<i>Heterosigma akashiwo</i>	19
References.....	20
Introduction to Sampling Protocols.....	21
SoundToxins Sampling and Data Recording SOPs.....	21
Field Measurements and Sample Collection.....	21
SoundToxins Sample Processing Protocol.....	22
Net Tow Processing.....	22
Whole-Water Processing.....	22
Site-Specific Processing.....	22
References.....	23

contents continued on following page

contents continued

SoundToxins Data Entry Protocol.....	24
How to Calculate the Volume of Water Filtered Through the Net	26
How to Calculate Semi-Quantitative Cell Concentration from Net Tow Material.....	26
How to Use a Palmer-Maloney Slide	27
Relative Abundance Examples.....	28
Appendices.....	29
Basic Morphological Terminology of Phytoplankton	30
SoundToxins Data Entry Sheets.....	32
Marine Zooplankton of Puget Sound	34

SoundToxins Overview

WELCOME TO SOUNDTOXINS!

Shellfish are critical to the culture, economy and ecology of Puget Sound. They shape habitats, provide food for humans and other species, and perform water-filtering functions important to all organisms that live in or near the Sound. Native American tribes have long incorporated shellfish into their daily lives through ceremony and art as well as food. Today Washington State is a national leader in farmed bivalve shellfish, an industry that provides more than 3,200 family-wage jobs and contributes an estimated \$270 million to the economy (Washington Shellfish Initiative 2011). The majority of shellfish-farming and recreational harvest opportunities are in rural communities. Recreation and tourism associated with shellfish harvesting on state-owned beaches annually accounts for more than \$1 million in license sales and an estimated economic value of \$5.4 million (Washington Shellfish Initiative 2011).

Ensuring safe and wholesome shellfish for consumption relies on water free of terrestrial and legacy pollutants and toxins from harmful algal blooms (HABs). A phytoplankton bloom can be harmful in several ways. Some blooms can produce anoxic (no oxygen) or hypoxic (low-oxygen) conditions in the water column. This occurs when one or two species dominate a bloom and block the sunlight from other organisms in the lower water column. Other plankton begin to die and decompose. The process of decomposition consumes oxygen. Fish die for lack of oxygen and decomposition continues. Eventually, the massive bloom dies as well, removing any additional oxygen from the water column. This entire process can lead to a fish and/or shellfish die-off, resulting in negative economic impacts.

Harmful algal bloom events lead to closures of shellfish beds, lost fisheries production, and reductions in tourism and associated service industries. Fisheries-related businesses close, insurance and unemployment rates rise, and public resources are redirected to advisories and monitoring programs.

Human health can also suffer during harmful algal blooms. About 50 known species of phytoplankton produce toxins. As toxins move through the food web, they bioaccumulate in the tissues of large fish and marine mammals. Humans can contract illnesses from eating contaminated shellfish and fish, and medical treatment can be expensive.

Several types of algal toxin present in Puget Sound require vigilant monitoring to ensure safe shellfish consumption. Hydrophilic (water-loving) toxins such as the domoic acid produced by *Pseudo-nitzschia* spp. and paralytic shellfish toxins from *Alexandrium catenella* are currently monitored and regulated by the Washington State Department of Health (WDOH). A recent explosion of various lipophilic (fat-loving) algal toxins, including dinophysistoxins from *Dinophysis* spp., have caused various human illnesses and prompted a complete ban on the importation of Washington shellfish into the European Union. Of greatest immediate concern is the presence of algal toxins associated with diarrhetic shellfish poisoning (DSP), which triggered a beach closure and a recall of commercial product from Sequim Bay in August 2011.

In response to the threat HABs present to human health and shellfish harvests along Puget Sound, NOAA created the SoundToxins program in 2006, as part of its Oceans and Human Health Initiative. SoundToxins is designed as a cost-effective citizen- and industry-based monitoring program to provide enough warning of HAB events to enable early or selective harvesting of seafood, which ultimately minimizes health risks and reduces economic losses. The program employs twin strategies:

- Using phytoplankton data to provide early warning of HAB events. By rapidly determining the relative abundance of key HAB species, SoundToxins helps WDOH pinpoint shellfish-growing areas requiring regulatory testing.
- Monitoring environmental parameters (e.g., temperature, salinity, macronutrients, toxins, chlorophyll) to determine the key variables that promote the initiation of harmful events and encourage proliferation of HAB species. Identifying these variables may help provide early warning of events.

Participants throughout the Puget Sound region collect seawater samples routinely and analyze them for salinity, temperature, and phytoplankton species. Volunteer monitors describe the phytoplankton species diversity and specifically identify and enumerate four target varieties: *Pseudo-nitzschia* species (causing amnesic shellfish poisoning, or ASP), *Alexandrium* species (causing paralytic shellfish poisoning, or PSP), *Dinophysis* species (causing diarrhetic shellfish poisoning, or DSP), and *Heterosigma akashiwo* (causing fish kills). In addition, monitors at some key locations also process samples for nutrients, chlorophyll, and toxins.

Since 2006, the program has demonstrated the effectiveness of an early warning system. This became especially clear during the Sequim Bay DSP incident in August 2011, when SoundToxins volunteers from the Jamestown S’Klallam Tribe alerted WDOH to elevated levels of *Dinophysis* spp.

WDOH maintains its own monitoring network of mussel cages throughout Puget Sound, but currently tests these mussels only for PSP toxins and domoic acid. Testing for DSP and other toxins stresses the already stretched state budget. SoundToxins monitoring targets high-risk sites that have an immediate need for testing of “new toxins” in shellfish. SoundToxins phytoplankton data, entered into a database in near-real time, lets WDOH allocate expensive shellfish testing for DSP toxins only when *Dinophysis* species are present. WDOH has hailed the importance of SoundToxins as an early warning system. In fact, WDOH acquired a modest amount of funding in early 2012 to create a new, easy to use database for participants and to support data management. Jerry Borchert, shellfish specialist for WDOH stated, “There is an urgent need for us to use SoundToxins data in real-time to pinpoint those shellfish growing areas where monitoring for DSP toxins is essential. This will help us to focus our resources in high risk areas.”

SoundToxins was originally supported through NOAA’s Oceans and Human Health Initiative with funding from the Northwest Fisheries Science Center’s (NWFSC) West Coast Center for Oceans and Human Health. Congress zeroed out the initiative’s budget in 2012, leaving a significant funding gap. Despite this cut, NWFSC has committed to support SoundToxins through in-kind staff contributions. In addition, Washington Sea Grant (WSG) joined as a program partner in 2008 and assumed the tasks of volunteer coordination, data management, and communications. WSG has succeeded in obtaining grants to support SoundToxins from the National Estuary Program’s Toxics and Nutrients Ambient Monitoring Program through the Washington State Department of Ecology and the NOAA Sea Grant Aquaculture Extension and Technology Transfer Program.

By volunteering with SoundToxins, you are helping to ensure a safe, sustainable harvest of shellfish and fish throughout Puget Sound.

A Brief Introduction to Marine Phytoplankton

Rita Horner
School of Oceanography, University of Washington

DEFINITION

The term “plankton” comes from the Greek planktos, meaning “to drift or wander”; thus these organisms float passively or have only limited ability to swim. Phytoplankton are plant plankton, mostly unicellular algae that are usually photosynthetic. They are sometimes called “floating pastures” because they provide food for so many marine organisms.

FEATURES

Phytoplankton underlie all animal production in the ocean, supporting the food webs that supply the world’s fisheries. They provide half of the world’s oxygen and are key players in the global biogeochemical cycling of carbon, nitrogen and sulfur.

Phytoplankton range in size from about 2 microns (μm) to 2 millimeters but commonly fall between 10 and 50 μm . They inhabit a wide range of environments, from puddles, lakes, and streams to ice, snow, and oceans. They live in a wide range of temperature, salinity, light, and nutrient conditions and across a wide range of temporal and spatial scales. Their distribution is limited by light and nutrients.

The cells have a variety of shapes ranging from round to elongate. They may have spines, horns, setae, or lists and may live as solitary cells or in colonies, often attached together in long or short chains. Some cells have flagella, whip-like structures that enable them to swim, albeit slowly. They have the usual organelles (nuclei, Golgi bodies, and mitochondria) and may also have chloroplasts, eye spots, ejectile structures (trichocysts), mucocysts, and skeletons.

Reproduction is usually asexual but in some cases sexual. It may produce resting cells, spores (e.g., from diatoms), or cysts (e.g., dinoflagellates).

The earliest studies of phytoplankton were taxonomic. They used light microscopy to observe such features as size, shape, color and swimming mode. Electron microscopes are now used: scanning electron microscopes (SEM) to view surface features and transmission electron microscopes (TEM) to view ultrastructure and external scales.

KINDS OF ORGANISMS

1. Diatoms

Diatoms are the best known and the most abundant group of phytoplankton in terms of both number of species (5,000 to 100,000 or more depending on the authority) and biomass. They occur in all the oceans from the poles to the tropics, but are most common in polar and temperate seas. They range in size from 2 to 200 μm , but may be as long as 4 mm.

Diatoms have traditionally been divided into two taxonomic groups based on the type of symmetry they display. These definitions are changing, but for SoundToxins purposes we will stick with the old groups. The centric diatoms (the Centrales order) have radial symmetry with surface patterns arranged along a central point. The pennate diatoms (Pennales order) have longitudinal symmetry with surface patterns arranged along an axis (Fig. 1).

A diatom’s cell wall (frustule) is a box-like silica shell with an organic covering. It has two halves, each consisting of a flat plate, valve, and marginal girdle bands. The larger half is called the epitheca; the smaller half, the hypotheca, fits into the epitheca. The rounded area between the valve and girdle is called the mantle (Fig. 1). Diatom shape varies, usually round or boat-shaped, but may be triangular, square, or elliptical. The silica walls are usually highly patterned with pores, ribs, minute spines, processes (natural projections or appendages), marginal ridges, and elevations, which indicate genera and species.

Cells may be solitary (*Ditylum*, *Coscinodiscus*) or joined in colonies with cells linked by:

1. Chitin secreted through strutted processes: *Thalassiosira*
2. Siliceous structures
 - a. Hollow extensions of tubular processes: *Stephanopyxis* (labiate processes), *Skeletonema* (strutted processes)
 - b. Solid spines or teeth: *Paralia*
 - c. Interlocking setae: *Chaetoceros*
 - d. Bipolar elevations: *Eucampia*
 - e. Bipolar elevations with spines: *Cerataulina*
3. Abutting valve faces: *Leptocylindrus*, *Fragilariopsis*
4. Mucilage pads or stalks
 - a. Mucilage pads at valve poles: *Thalassionema* (stars or zig-zags)
 - b. Mucilage stalks: *Licmophora*
 - c. Valve face: *Fragilariopsis* (ribbon chains)
 - d. Part of valve: *Pseudo-nitzschia* (stepped colonies)
5. Mucilage tubes: *Nitzschia*, *Berkeleya*
6. Amorphous masses of mucilage: *Thalassiosira*

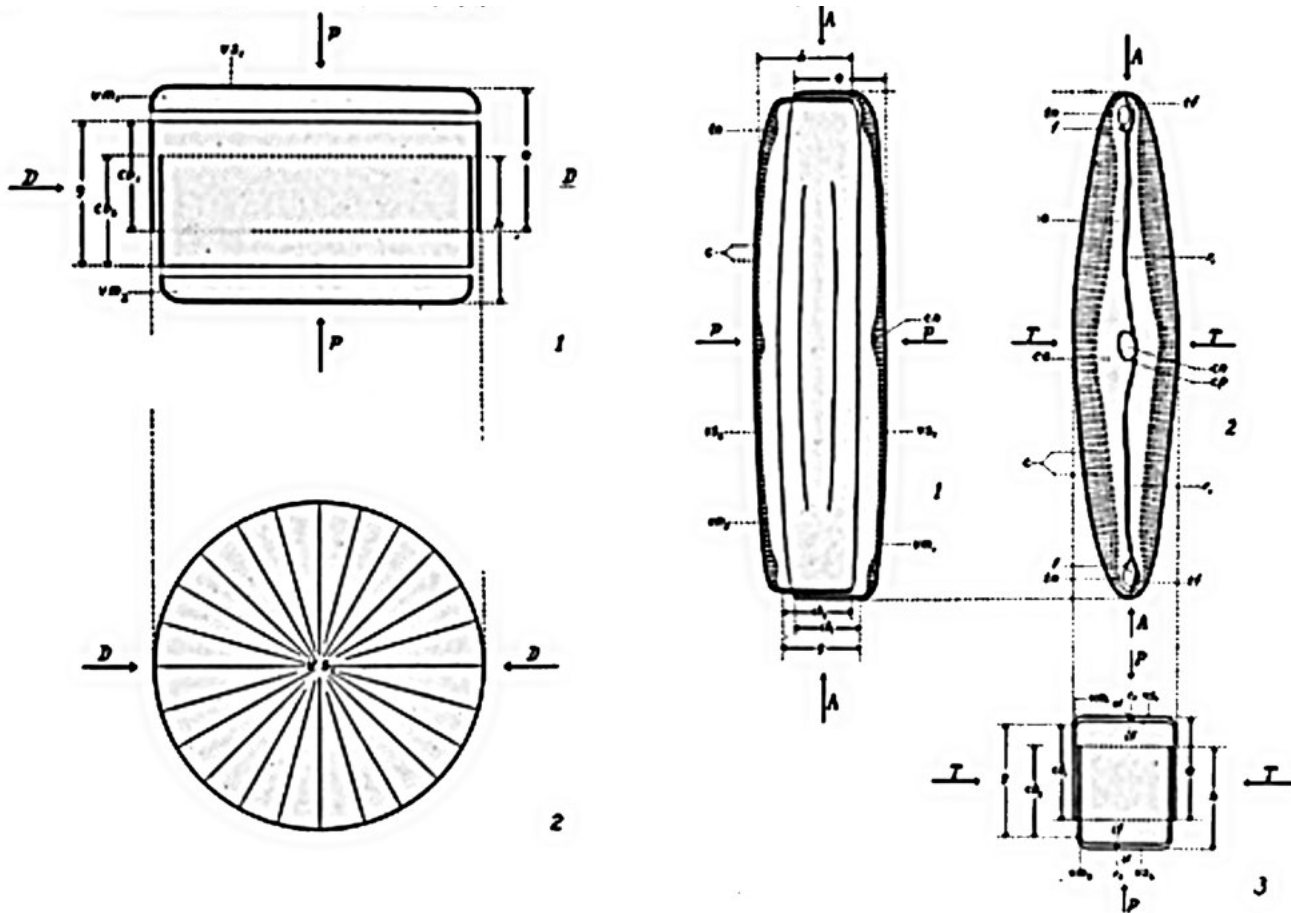

Figure 1. Diatom frustules. Left — centric diatom: (1) girdle view; (2) valve view. Structure: (e) epivalve; (h) hypovalve; (g) girdle consisting of connecting bands from epi- and hypo-valves; (vm) valve mantle; (D) diameter. Right — pennate diatom: (1) Broad girdle view; (2) valve view; (3) narrow girdle view (end). Axes: (A) apical; (P) pervalve; (T) transapical. Structure: (r) raphe. Redrawn from Cupp (1943).

Movement in diatoms is limited to those pennate species that have slits called raphes and occurs only when a raphe contacts a solid surface. Mucopolysaccharide filaments are secreted into the raphe and become attached to the substrate. Actin filaments inside the cell move along the secreted filaments, and the cell glides. When the raphe passes over, the mucopolysaccharide detaches and remains behind as a sticky trail. The only flagellated cells occurring among diatoms are the male gametes of centric species.

Reproduction in diatoms is primarily via asexual cell division. Each daughter cell receives half of the parent cell's theca as an epitheca and forms a new hypotheca. As a result, a diatom population's average cell size decreases; it must recover or the population will die out. When cells are about one-third their maximum size, sexual reproduction occurs. Gametes emerge and fuse to form a zygote that sheds the silica theca and forms a large sphere, the auxospore, covered by an organic membrane. The initial cell, a new cell of maximum cell size, forms within the

auxospore and begins a new generation (Fig. 2). Depending on the species, sexual reproduction may be infrequent, sometimes occurring only every 20 years or more.

When environmental conditions become unfavorable, some diatoms, especially centric ones, produce resting spores. The resting spores may resemble the vegetative cells or may look so different, they have been described as different species (e.g., *Chaetoceros* spp.). Resting spores germinate when environmental conditions become favorable. They may require a dormancy period before germination, or may germinate within a few days.

Diatoms are primarily photosynthetic. A few are heterotrophs, drawing their nutrition from outside rather than producing it by photosynthesis, and some can live heterotrophically in the dark if an appropriate organic carbon source is available.

Healthy cells are golden brown in color. Unhealthy cells are greenish. Diatoms store food reserves as chrysolaminarin and lipids.

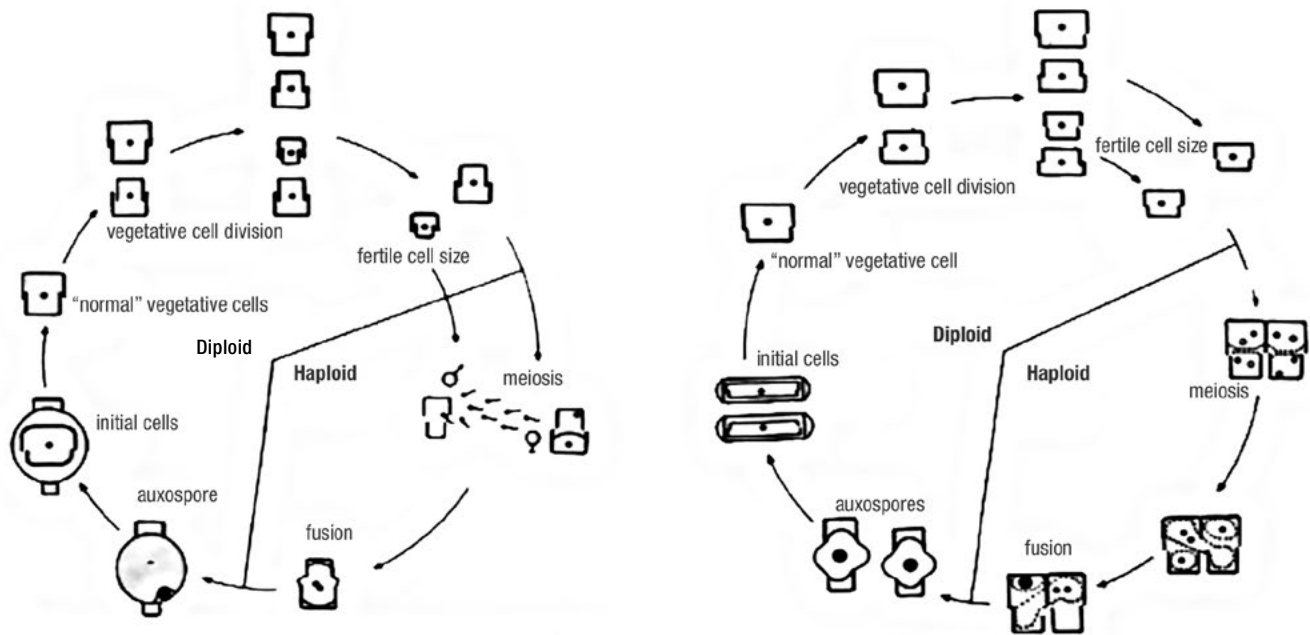

Figure 2. Diatom life cycles: (a) sexual reproduction of a centric diatom (oogamy) and (b) of a pennate diatom (morphological isogamy, physiological anisogamy). ● = zygote, ● = nucleus, ○ = pycnotic nucleus. From Hasle and Syvertsen (1996).

2. Dinoflagellates

Dinoflagellates are the second most important group of phytoplankton, comprising about 1,700 species (Sournia et al. 1991). They occur in all the oceans but are most successful in the tropics. They range in size from 2 μm to 2 mm.

A dinoflagellate's cell wall is complex, consisting of a layer of vesicles with or without cellulosic plates. If plates are present, the cells are said to be thecate, or armored; if plates are not present the cells are athecate, unarmored or naked. The arrangement of the plates is specific to each genus. The theca may have horns, spines or lists, and the plates may have ornaments of pores, depressions, spines, ridges, and reticulations. Some taxa have delicate external scales or siliceous or calcareous skeletons. Most dinoflagellates are solitary, but a few genera, including *Alexandrium*, *Gymnodinium* and *Peridiniella*, contain species that produce chains.

Most dinoflagellate cells are divided into two parts by a horizontal groove or cingulum known as the girdle (Fig. 3). The anterior part is the epitheca (epicone if plates are not present), the posterior part is the hypotheca (hypocone without plates). The two parts may be equal or unequal in size; girdle placement helps define genera. A vertical groove, the sulcus, splits the hypotheca and may extend into the epitheca. Dinoflagellates have two dissimilar flagella that emerge through one or two pores on the ventral side of the cell near the ends of the girdle or from the anterior part of the cell (Fig. 3). The ribbon-like transverse flagellum, located in the girdle, beats with a helical or semi-helical motion, moving the cell forward. The longitudinal (trailing) flagellum, located in the sulcus, is cylindrical or flattened and beats with one or a few waves that cause the cell to rotate and move forward.

Reproduction is either asexual or sexual (Fig. 4). In asexual reproduction, cells divide by binary fission. In sexual reproduction, gametes are formed and fuse to form a zygote. The zygote may be a nonmotile resting stage (hypnozygote) morphologically different from the vegetative cell that settles to the bottom and remains dormant for some period of time, or a motile zygote (planozygote) that is morphologically similar to the vegetative cell. Both may occur in a single life cycle (e.g., *Alexandrium*).

A

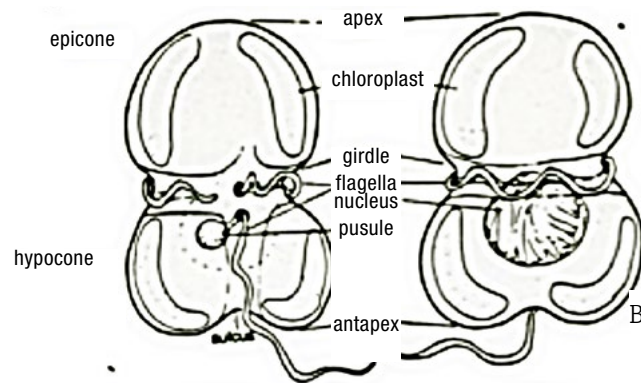

B

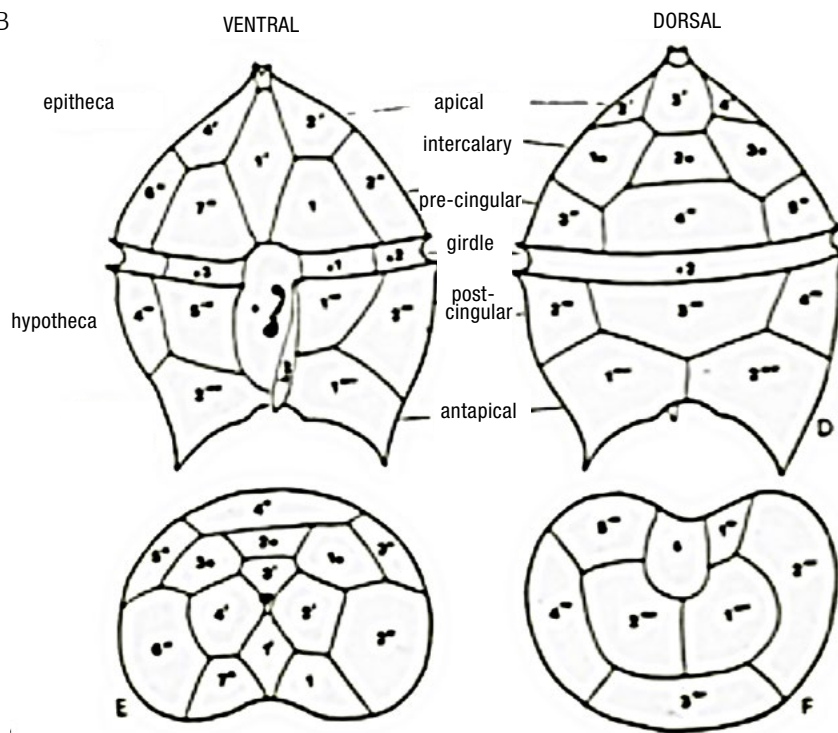

Figure 3. Top. Atecate (naked, unarmored) dinoflagellate: (A) ventral side with girdle and sulcus with flagella; (B) dorsal side. Bottom. Thecate (armored) dinoflagellate showing plate pattern: (C) ventral side with girdle and sulcus; (D) dorsal side; (E) cell apex; (F) cell antapex. Redrawn from Dodge (1982).

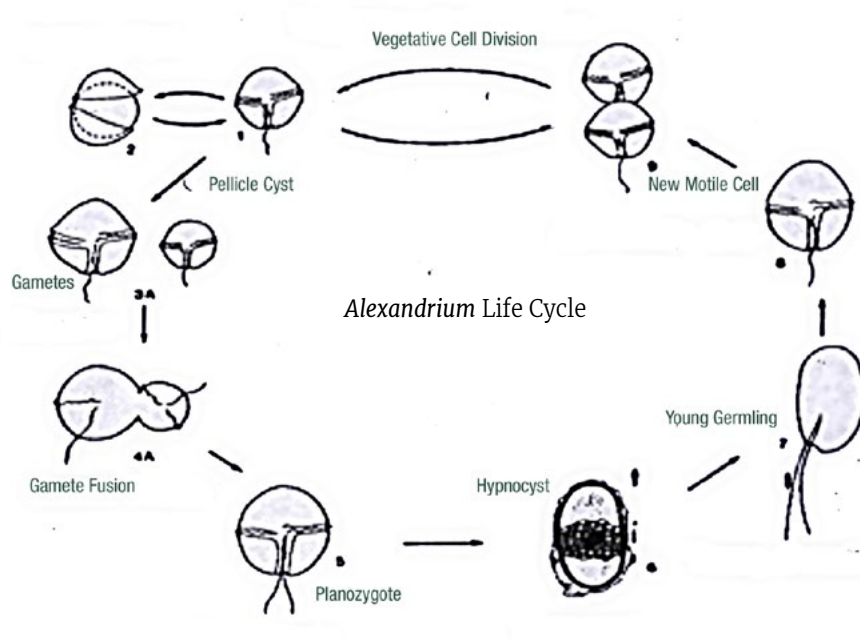

Figure 4. Dinoflagellate life cycle (*Alexandrium* spp.). Stages: (1) vegetative cell; (2) pellicle (temporary) cyst; (3) gametes; (4) fusing gametes; (5) planozygote (motile cell); (6) hypnozygote; (7) and (8) planomeiocyte (germinated cell); (9) pair of vegetative cells after division. From Anderson (1998).

Chloroplasts may or may not be present. Dinoflagellates may be autotrophic or heterotrophic; some autotrophs are now known to be mixotrophs, combining photosynthesis and grazing. Some dinoflagellates are parasitic and some are symbiotic. Some have specialized structures such as feeding veils to trap food and peduncles to suck food from other organisms. Their reserve foods are starch and oil.

Dinoflagellates are divided into two groups depending on where their flagella emerge (Fig. 5). Desmokyonts have two dissimilar flagella rising from the anterior of the cell (*Prorocentrum*), while dinokyonts have flagella inserted ventrally, with the transverse flagellum located in the cingulum and the longitudinal (trailing) flagellum in the sulcus (*Protoperidinium*).

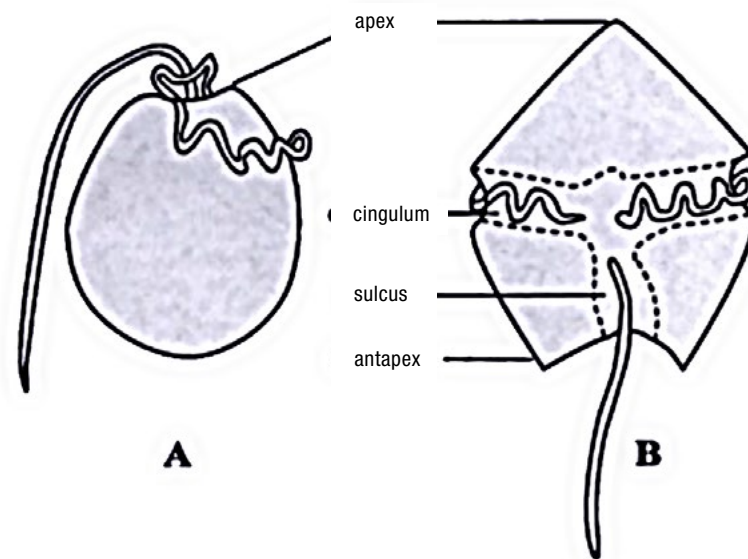

Figure 5. Schematic of dinoflagellates showing flagellar insertion: (A) desmokyont; (B) dinokyont. Redrawn from Taylor (1987).

3. Flagellates

Flagellates are a mixed bag of mostly unicellular motile cells that tend not to preserve well or to be very well known (Fig. 6). They occur in all oceans, lakes, rivers, streams, etc., from the poles to the tropics. They commonly range in size from about 2 to 20 μm but may be larger. When counting samples, flagellates are often grouped nonsystematically into size classes to obtain numbers and/or biomass.

Cell coverings may be composed of organic strips (euglenoids), proteinaceous plates (cryptomonads), or silica (silicoflagellates). They may be smooth or covered with scales of one or more kind that may be organic, silicified, or calcified. The scales have patterns that are used in taxonomy, but transmission electron microscopy is necessary to see them.

Cells may have 1, 2, 4, 8, or 16 flagella, which may be covered in hairs or scales. Flagellates use their flagella for swimming and/or attachment. One group, the Prymnesiophyceae (Haptophyceae), also have a thread-like appendage of variable length called the haptonema, located between the two flagella and used to anchor the cell to a substrate or capture food.

Reproduction is mostly by cell division. Most flagellates are known only as motile cells, the dominant stage in the life cycle, but some have nonmotile stages that may be described as different genera. Some have more than one motile stage or gelatinous stages (e.g., *Phaeocystis*). Some produce cysts that may degrade quickly or may fossilize (Chrysophyceae).

Chloroplasts may be present or absent. Pigment composition is variable depending on the taxonomic group and may sometimes serve to determine which classes of algae are present in a sample, using CHEMTAX. Cells may be autotrophs, heterotrophs, or mixotrophs.

Flagellates are divided into taxonomic groups based on flagella (number, presence of scales or hairs), cell walls, skeletons, presence or absence of a haptonema, pigments, and other characteristics. The group that SoundToxins is most interested in is the Raphidophyceae, a relatively small group of freshwater green and marine golden-brown flagellates that includes *Heterosigma*.

Heterosigma range in diameter from about 10 to more than 25 μm . Their cells, naked and dorsoventrally flattened, can change shape. The cell surface has a glycocalyx composed of complex carbohydrates and glycoproteins. Mucocysts located near the chloroplasts produce large amounts of mucus. Two unequal heterodynamic flagella are present: one with hairs is directed forward and one smooth is directed posteriorly; cells rotate while swimming. There are many small, golden brown, discoid chloroplasts located along the periphery of the cells. *Heterosigma* is photosynthetic. Reserve food is lipids.

Reproduction is by longitudinal cell division with replication of the flagella indicating the onset of division. Cyst stages are present and germination can occur in the dark. Benthic masses of nonmotile cells enclosed in mucilage may be present. *Heterosigma* is a vertical migrator, descending at night and ascending in the day.

Raphidophycean flagellates produce hemolytic, neurotoxic, and hemagglutinin compounds, as well as hydrogen peroxide and superoxide, hydroxyl radicals that may kill fish. Some raphidophyceans, including *Heterosigma*, produce toxins similar to brevetoxins. However, wild blooms of *Heterosigma* are not always toxic.

REFERENCES

- Anderson, D.M. 1998. Physiology and bloom dynamics of toxic *Alexandrium* species, with emphasis on life cycle transitions. In: D.M. Anderson, A.D. Cembella and G.M. Hallegraeff (eds.) *Physiological Ecology of Harmful Algal Blooms*. NATO ASI Series, Vol. G 41. Pp. 29–48.
- Chrétiennot-Dinet, M.J. 1990. Chlorarachniophycées, Chlorophycées, Chrysophycées, Cryptophycées, Euglenophycées, Eustigmatophycées, Prasinophycées, Prymnesiophycées, Rhodophycées, Tribophycées. In: A. Sournia (ed.) *Atlas du Phytoplancton Marin*, Vol. 3. Editions du Centre National de la Recherche Scientifique, Paris. Pp. 1–261.
- Cupp, E.E. 1943. Marine plankton diatoms of the west coast of North America. *Bull. Scripps Inst. Oceanogr.* 5:1–238.
- Dodge, J.D. 1982. *Marine Dinoflagellates of the British Isles*. Her Majesty's Stationery Office, London. 303 p.
- Hasle, G.R. and E.E. Syvertsen. 1996. Marine diatoms. In: C.R. Tomas (ed.) *Identifying Marine Diatoms and Dinoflagellates*. Academic Press, San Diego. Pp. 5–385.
- Sournia, A., M.-J. Chretiennot-Dinet, and M. Ricard. 1991. Marine phytoplankton: how many species in the world ocean? *J. Plankton Res.* 13:1093–1099.
- Taylor, F.J.R. 1987. Dinoflagellate morphology. In: F.J.R. Taylor (ed.) *The Biology of the Dinoflagellates*. Blackwell Scientific Publications, Oxford, pp. 24–91.

1. Chlorarachniophyceae



2. Chlorophyceae



3. Chrysophyceae



4. Cryptophyceae



5. Euglenophyceae



6. Eustigmatophyceae



7. Dinophyceae



8. Raphidophyceae



9. Prymnesiophyceae

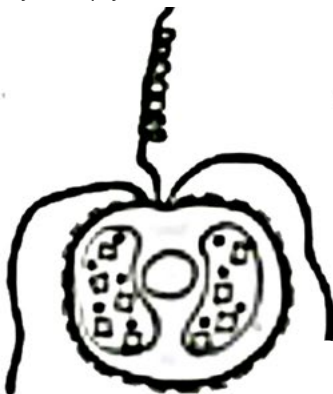

10. Dictyochophyceae

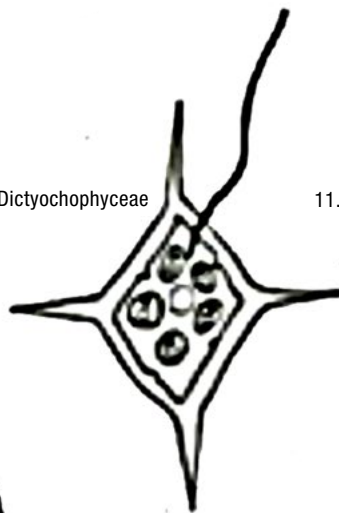

11. Tribophyceae



12. Prasinophyceae



Figure 6. Line drawings with hair and scale patterns of various classes of flagellates. From Chrétiennot-Dinet (1990).

Phytoplankton Identification

As mentioned previously in Dr. Horner’s “Brief Introduction to Marine Phytoplankton” (p. 3), important features for identifying phytoplankton include the shape of the cell wall (e.g., round, boat-shaped, triangular, square, or elliptical), patterns on the cell wall (pores, ribs, spines), cell movement, the presence or absence of chloroplasts, and the presence or absence of flagella. This section is dedicated to phytoplankton identification. It comprises species-specific plankton identification sheets organized according to grouping (diatoms and dinoflagellates). For an illustrated guide on phytoplankton morphological terminology, please see the appendix (p. 30).

In addition to the information SoundToxins participants need to identify plankton, the species-specific sheets contain information on toxicology, infection vectors, regional species of concern, action levels, and SoundToxins action. The toxic “action levels” represented are U.S. Food and Drug Administration (USFDA) thresholds for shutting down fisheries. A “SoundToxins action level” should be reported to the SoundToxins alert line.

Other phytoplankton identification resources include A Taxonomic Guide to Some Marine Phytoplankton (2002) by Dr. Rita Horner and an online guide by the University of British Columbia’s Phyto’pedia (www.eos.ubc.ca/research/phytoplankton/).

SPECIES SPECIFIC IDENTIFICATION SHEETS

1. DIATOMS

Chaetoceros concavicornis

Acentric diatom widely distributed in northern temperate and coldwater areas, known to kill fish, especially salmon in net pens.

IDENTIFICATION

Cells joined in straight chains; valves unlike, with upper valve rounded with setae arising near the center and lower valve flat with setae arising inside the valve margin; apertures distinct; setae become wider away from the cell and are covered with small spines.

TOXICOLOGY

Mechanism for toxicity is not known, but cells thought to become trapped in gill filaments, causing irritation and mucus production by the gill tissue.

REGIONAL SPECIES

Chaetoceros concavicornis. Similar species: *C. convolutus*.

VECTORS

None.

LOCAL DISTRIBUTION

Inland waters of Puget Sound and British Columbia, sometimes forming blooms.

MONITORING

Daily by local fish farmers during summer months when phytoplankton most likely to occur.

SoundToxins action: "Common," "Bloom," or >5,000 cells/L.

ANALYSES

Cell counts.

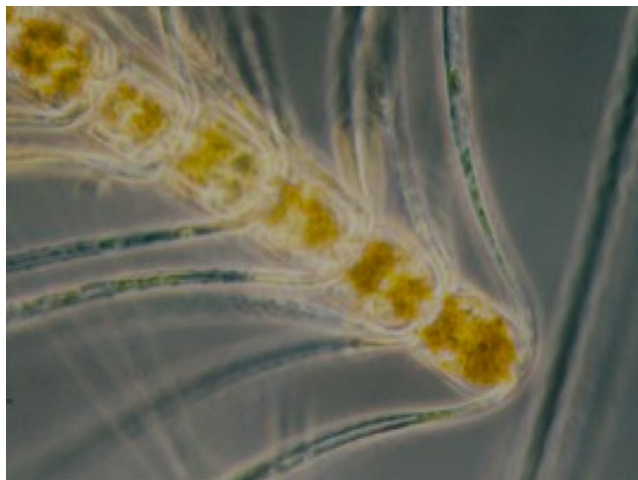

A. Light microscope image. Note setae get larger away from cells. Photo from Horner (2002).

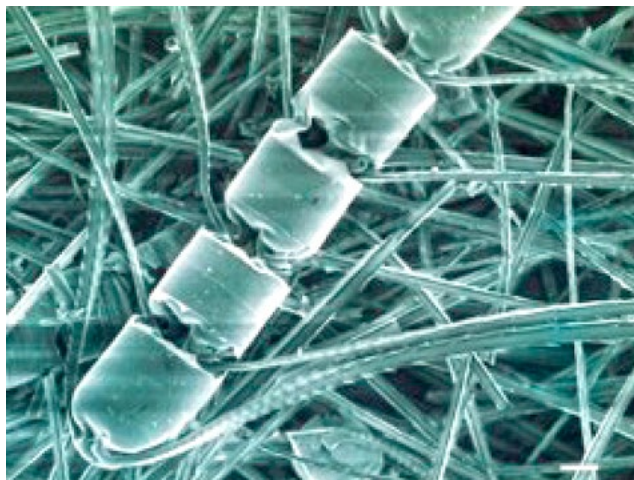

B. Scanning electron microscope image. Note small spines on setae. Photo from Horner, unpublished.

Pseudo-nitzschia spp.

A pennate diatom genus widely distributed in polar, temperate, and subtropical waters worldwide.

IDENTIFICATION

Cells occur in stepped chains (cell ends overlap). Species difficult to identify in light microscope (LM). Need scanning and transmission electron microscopy for positive identification. Use size classes: long and wide (a/h/f), long and narrow (p/m), short and narrow (pd/d/c).

TOXICOLOGY

Some species known to produce domoic acid (DA) associated with amnesic shellfish poisoning (ASP) that causes gastrointestinal and neurological problems in humans, marine mammals, and sea birds.

REGIONAL SPECIES

P. australis, *P. heimii*, *P. fraudulenta*, *P. pungens*, *P. multiseriis*, *P. cuspidata*, *P. delicatissima*, *P. pseudodelicatissima*.

VECTORS

Bivalve molluscs (mussels, razor clams), herbivorous fish (anchovies, sardines), Dungeness crab.

LOCAL DISTRIBUTION

Pacific west coast (Alaska to California), all inland waters of Puget Sound.

MONITORING

Weekly from March through October and every other week from November through February.

Water samples for presence, cell abundance (counts, estimates).

SoundToxins action level: report from 10x whole water results.

Large cells (*P. australis*, *P. heimii*, *P. fraudulenta*; *P. pungens*, *P. multiseriis*

= a/h/f/p/m) > 50,000 cells/L (“Common” or “Bloom”).

Small cells (*P. pseudodelicatissima*, *P. delicatissima*, *P. cuspidata* = pd/d/c)

> 1,000,000 cells/L (“Common” or “Bloom”).



A. *Pseudo-nitzschia*: a/h/f = (large, broad cells); p/m = (large, narrow cells). Photo from Brian Bill, NOAA.

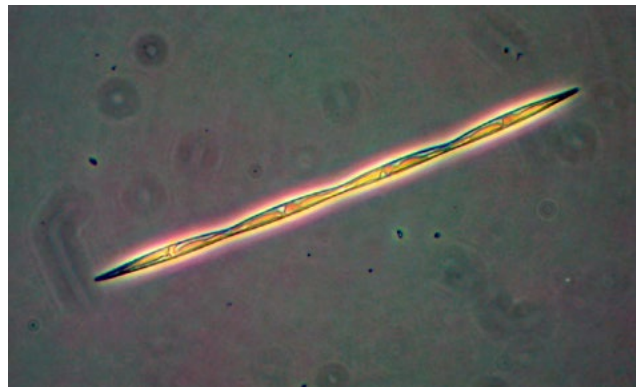

B. *Pseudo-nitzschia*: a/h/f (large, broad cells). Photo from Brian Bill, NOAA.

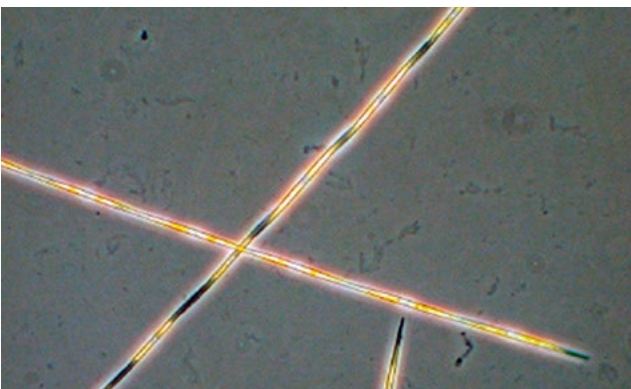

C. *Pseudo-nitzschia*: pm (large, narrow cells). Photo from Brian Bill, NOAA.

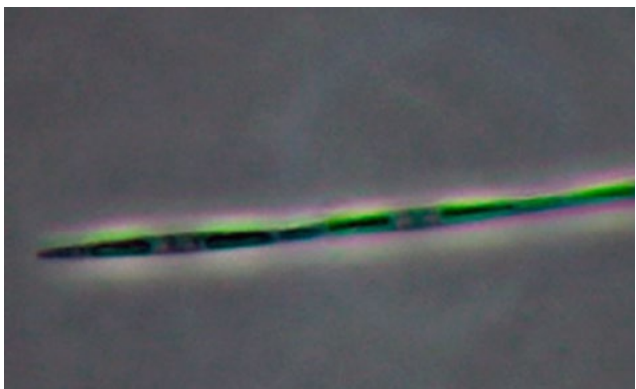

D. *Pseudo-nitzschia*: pd/d/c (small, narrow cells). Alan Sarich, Washington Department of Fish & Wildlife.

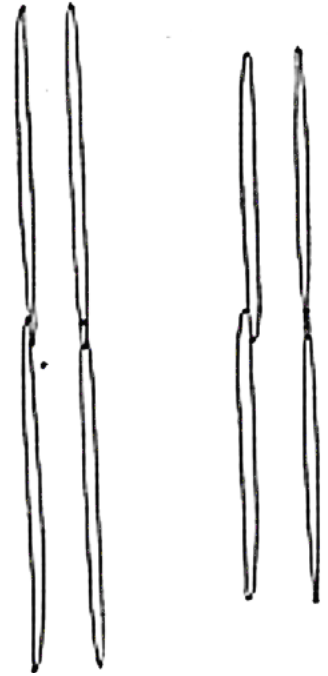

P. pungens/multiseries

2. DINOFLAGELLATES

Alexandrium spp.

Athecate dinoflagellate genus widely distributed in temperate, subtropical and tropical oceans worldwide. Many species found primarily in coastal areas.

IDENTIFICATION

Cells distinguished by cell size and shape, shape and position of the apical pore complex, presence and size of the ventral pore, and chain formation (cells solitary or forming chains, but chain formers can occur as single cells).

TOXICOLOGY

Some species known to produce paralytic shellfish toxins (PSTs), including saxitoxin, associated with paralytic shellfish poisoning that causes neurological symptoms and may lead to respiratory arrest in humans. May also affect marine mammals.

REGIONAL SPECIES

A. catenella, *A. tamarense*, *A. acatenella*.

VECTORS

Bivalve molluscs, marine snails, barnacles, Dungeness crabs, anchovies, sardines.

LOCAL DISTRIBUTION

Pacific west coast (Alaska to California), inland waters of Puget Sound.

MONITORING

Weekly from March through October and every other week from November through February.

Water samples for presence, cell abundances (counts, estimates); assume toxin possible when cells are present. Count from net tow.

Shellfish collected and tested biweekly at ~70 sites (WA Department of Health).

SoundToxins action: report any presence of this organism.

ANALYSES

USFDA Action level: 80 µg/100 g shellfish tissue of toxins.



Alexandrium chain. From Horner (2002).

Dinophysis spp.

A thecate dinoflagellate genus widely distributed in tropical to cold temperate waters worldwide.

IDENTIFICATION

Cells laterally flattened; epitheca small, hypotheca large, girdle moderately wide and bordered by lists (wings), ventral sulcus bordered by lists; chloroplasts present or absent.

TOXICOLOGY

Produces lipophilic toxins (diarrhetic shellfish toxins or DSP) that can accumulate and co-occur in shellfish. Toxins are okadaic acid (OA), a known tumor promoter; dinophysistoxins (DTX1-6), which are derivatives of OA; and pectenotoxins (PTX) harmful to the liver. Symptoms are nausea, vomiting, diarrhea; recovery in a few days without treatment.

REGIONAL SPECIES

D. acuminata, *D. acuta*, *D. fortii*, *D. norvegica*, *D. odiosa*, *D. parva*, *D. rotundata*, *D. tripos*.

VECTORS

Bivalve shellfish.

LOCAL DISTRIBUTION

Pacific west coast (Alaska to California), all inland waters of Puget Sound.

MONITORING

Weekly from March through October and every other week from November through February.

Water samples for presence, cell abundances (counts, estimates). Shellfish when cells reach action level.

SoundToxins action: report any increase from "Present" to "Common" or "Common" to "Bloom," > 20,000 cells/L or any increase from a few (5,000-10,000 cells/L) to > 10,000 cells/L in net tow.

ANALYSES

Cell counts.

USFDA action level: 160 µg OA/kg shellfish edible parts.

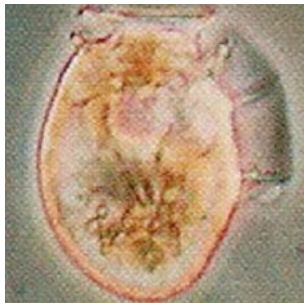

1. *D. acuminata*

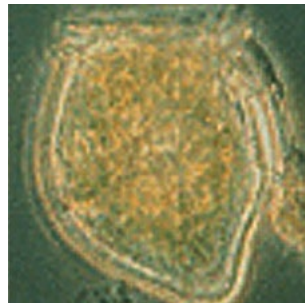

2. *D. acuta*

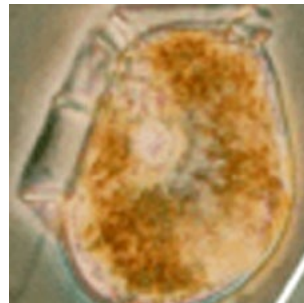

3. *D. fortii*

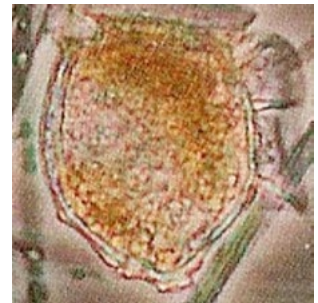

4. *D. norvegica*



5. *D. rotundata*



6. *D. tripos*

Regional *Dinophysis* species. Photos 1-5 from Horner (2002); photo 6 from Port Townsend Marine Science Center.

Gonyaulax spinifera (Claparède and Lachmann) Diesing

A thecate dinoflagellate distributed in estuarine, neritic, and cosmopolitan waters in the Pacific and Atlantic oceans, Gulf of Mexico, and Mediterranean Sea.

IDENTIFICATION

Small to medium cells, 23–50 µm long and 30–40 µm wide. The cingulum is excavated and descending with the ends separated by at least two cingulum widths. The epitheca is conical with a short to moderate apical horn. Several, usually two, spines on the antapex. A single multilobed chloroplast is present.

Cells are often confused with other small, round brown dinoflagellates, especially with other *Gonyaulax* species (e.g., *G. digitale* and *G. diegensis*). Forms cysts. A number of cyst genera have been described and associated with various *Gonyaulax* species. *G. spinifera* is a species complex based on confusion arising from thecate stages identified as *G. spinifera* that have hatched from different cyst genera.

TOXICOLOGY

Produces yessotoxins.

VECTORS

Bivalve shellfish.

LOCAL DISTRIBUTION

In the Anacortes/Port Townsend area and along the Pacific coast extending into British Columbia; blooms may form in summer.

MONITORING

Weekly from March through October and every other week from November through February.

ANALYSES

Cell counts.

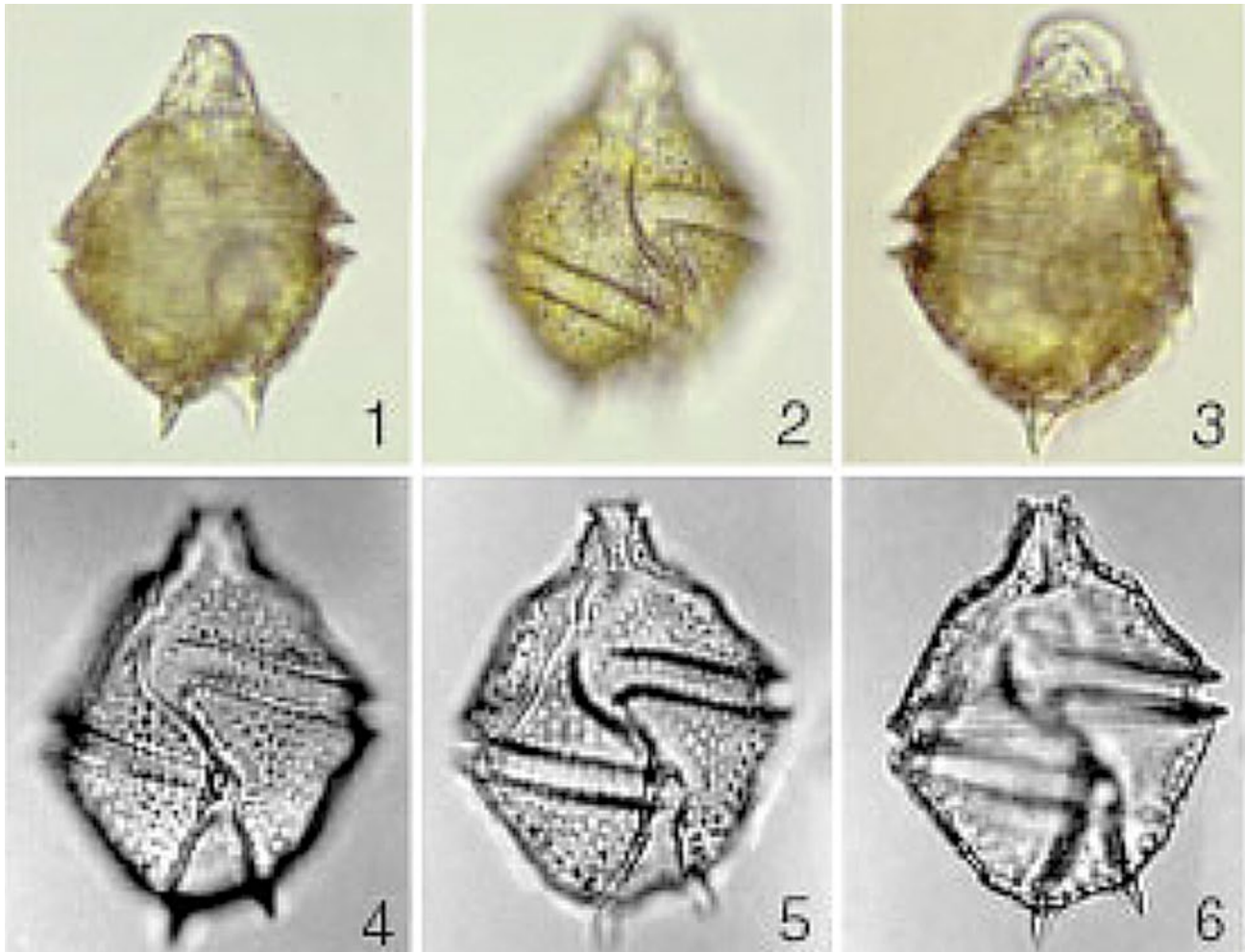

Gonyaulax spinifera (Claparède and Lachmann) Diesing (width: 20–50 µm). Photo by Yasuwo Fukuyo.

Protoceratium reticulatum (Claparède & Lachmann) Bütschli

A thecate dinoflagellate distributed in estuarine and neritic waters, cold temperate to subtropical oceans worldwide.

IDENTIFICATION

Cells polyhedral in shape with strong reticulations that often mask the plates; cells small to medium, 25–55 µm long, 25–35 µm wide. Epitheca is a broad cone with ~straight sides, shorter than hypotheca; hypotheca has straight to convex sides, rounded to squarish antapex with no spines. Cingulum nearly medium, slightly descending. Chloroplasts present, giving the cells a deep brown color.

Cells are easily confused with other smallish, round brown cells including solitary *Alexandrium* cells and some *Gonyaulax* species. Populations from South Africa were described as *Gonyaulax grindleyi* Reinecke, which remains a synonym. Cysts, described as *Operculodinium centrocarpum* (Deflandre & Cookson) Wall (also known as *Hystriochosphaeridium centrocarpum* Deflandre & Cookson), are spherical with dense ornamentation of tapering spines with hooked tips.

TOXICOLOGY

Produces yessotoxins.

VECTORS

Bivalve shellfish.

LOCAL DISTRIBUTION

Throughout Puget Sound, often in the Sequim Bay/Port Townsend areas; blooms may form in mid to late summer

MONITORING

Weekly from March through October and every other week from November through February.

ANALYSES

Cell counts.

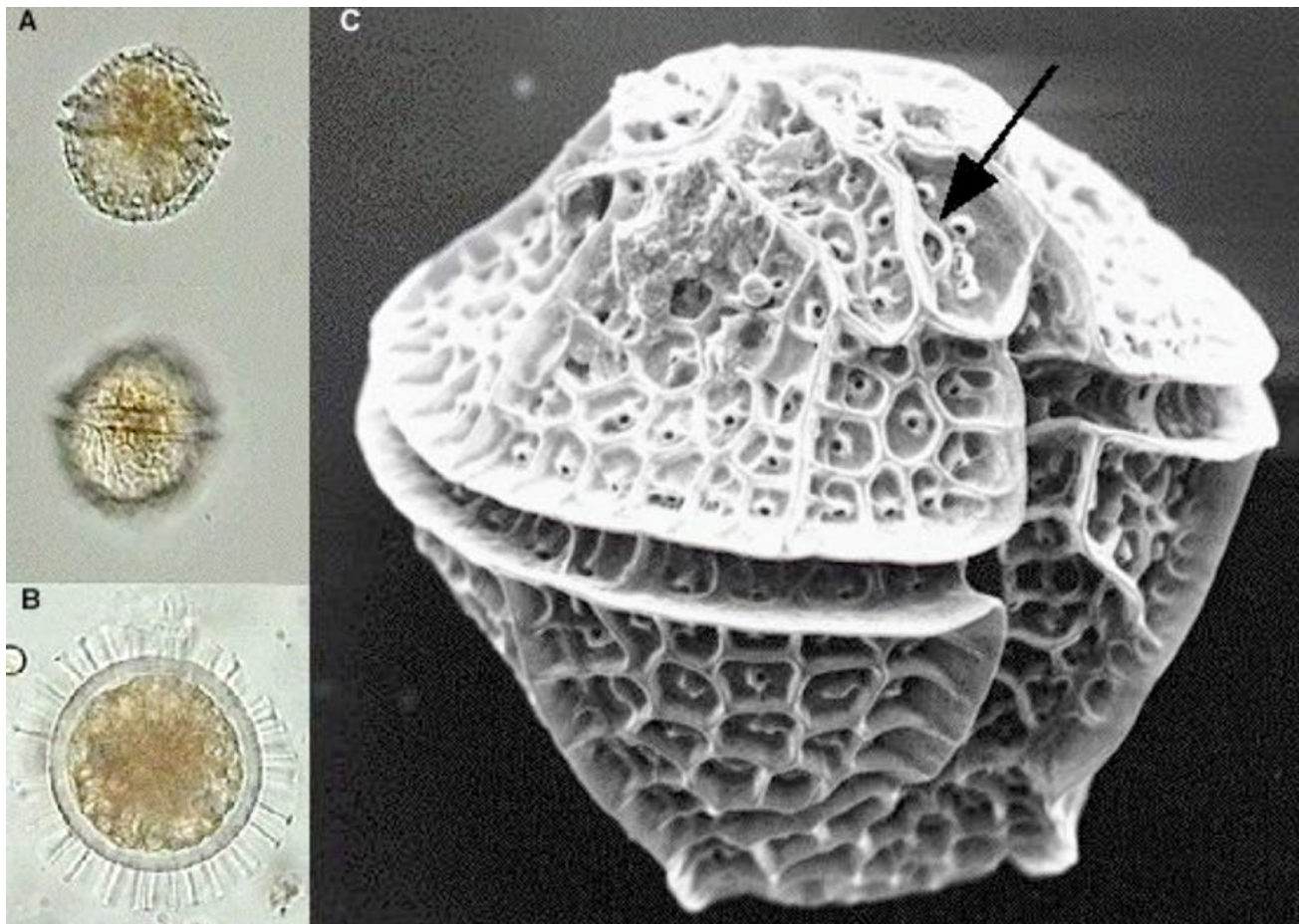

Protoceratium reticulatum: (A) Light microscopy, two focal planes; (B) light microscopy, cyst; (C) Scanning Electron Microscopy, whole cell with ventral pore (arrow). Photo from http://media.nordicmicroalgae.org/large/Protoceratium%20reticulatum_2.jpg.

Scrippsiella trochoidea (Stein) Loeblich III

A thecate dinoflagellate distributed in estuarine and neritic waters, cosmopolitan in temperate waters.

IDENTIFICATION

Small to medium cells, 16–36 µm long, 20–23 µm wide, pear-shaped. Epitheca conical with apical process that is often clear; hypotheca round with no projections. Cingulum medium, excavated. Chloroplasts present.

Cells are often confused with other small, round, brown dinoflagellates including other *Scrippsiella* species, *Pentaparsodinium*, and *Enciculifera*; thus distribution records may be confusing. Forms ovoid calcareous cysts.

TOXICOLOGY

Not known to be toxic.

VECTORS

None.

LOCAL DISTRIBUTIONS

Inland waters of Puget Sound; blooms may form in summer.

MONITORING

Weekly from March through October and every other week from November through February.

ANALYSES

Cell counts.



A. *Scrippsiella* cell; B. *Scrippsiella* cyst. Photo from <http://nordicmicroalgae.org/taxon/Scrippsiella%20trochoidea>

3. FLAGELLATES

Heterosigma akashiwo

A photosynthetic, flagellated organism widely distributed in temperate coastal and brackish waters.

IDENTIFICATION

Cells slightly compressed with two unequal flagella that arise from a subapical, lateral groove; many golden brown chloroplasts; rigid cell wall absent, so cells readily change shape; rapid swimmers.

TOXICOLOGY

Mechanism for toxicity not known, but suggestions include brevetoxin-like compounds, reactive oxygen species (hydrogen peroxide), hemagglutin or hemolysing compounds, mucus or lectin-like polysaccharides. Kills finfish, especially in net pens, as well as wild fish; known for antagonistic effects on organisms ranging from bacteria to fish.

REGIONAL SPECIES

Heterosigma akashiwo.

VECTORS

None.

LOCAL DISTRIBUTION

Pacific coast from British Columbia to California, inland waters of British Columbia and Puget Sound especially in lower salinity waters.

MONITORING

Daily by finfish growers during spring, summer; weekly by SoundToxins from March through October and every other week from November through February.

SoundToxins action: report presence of any cells.

ANALYSES

Cell counts, estimates in whole water.

Action level: >500,000 cells/L.

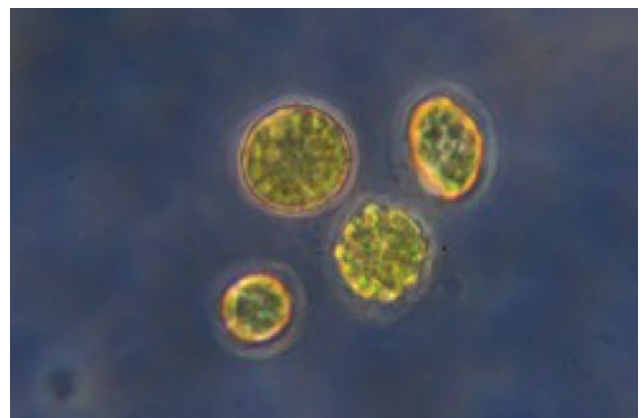
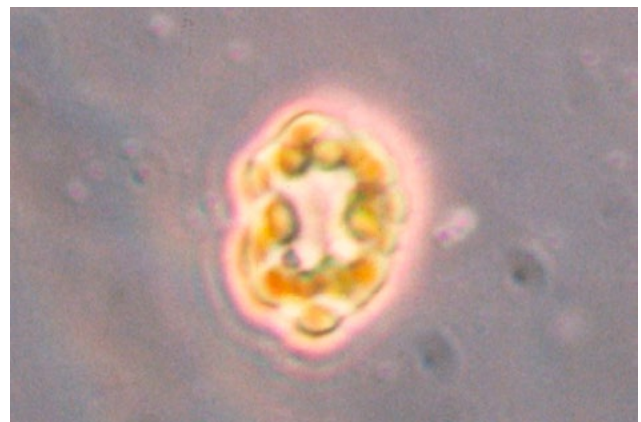
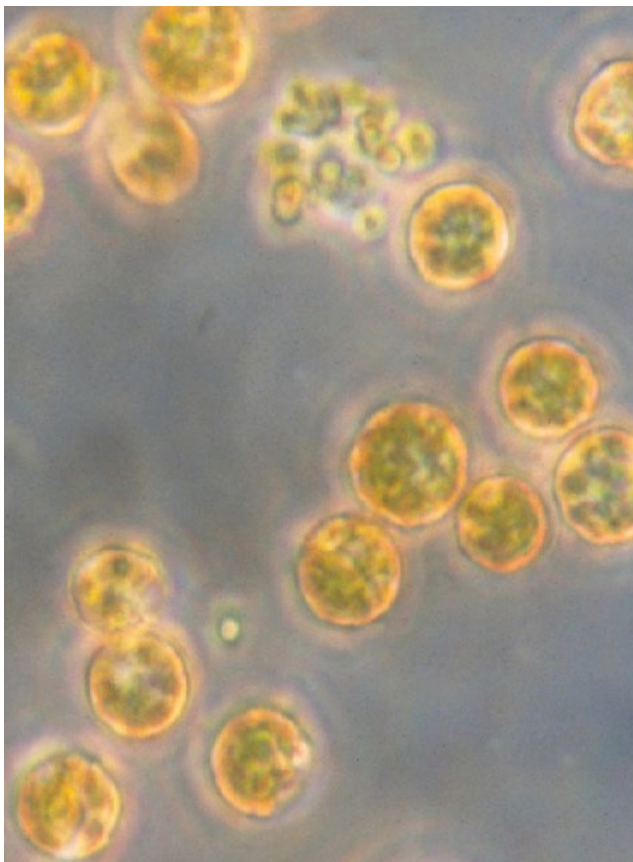

Heterosigma cells. Photos from Horner (2002).

REFERENCES

- Anderson, D.M. 1998. Physiology and bloom dynamics of toxic *Alexandrium* species, with emphasis on life cycle transitions. Nato ASI Series G Ecological Sciences, pp. 41, 29–48.
- Hasle, G.R. 1972. The distribution of *Nitzschia seriata* Cleve and allied species. Nova Hedwigia, pp. 39, 171–190.
- Horner, R.A. 2002. A Taxonomic Guide to Some Common Marine Phytoplankton, Biopress Ltd., pp. 69, 114–117, 120, 143, 168.

Introduction to Sampling Protocols

This section provides step-by-step instructions for procedures ranging from the collection of your phytoplankton sample through identification, sample archiving, alerting the SoundToxins notification system, and entering observations and data into the SoundToxins database. It also includes information on sample processing, phytoplankton calculations, Palmer-Maloney slide usage, and how to determine phytoplankton genera. These protocols have been approved by the Washington State Department of Ecology under the quality assurance project plan “SoundToxins Partnership – HABs Monitoring.” As always, if you need additional assistance, please email soundtox@uw.edu and we will be happy to help.

SOUNDTOXINS SAMPLING AND DATA RECORDING SOPS

Field Measurements and Sample Collection

FIELD SUPPLIES

- Bucket
- 2-liter plastic bottle
- Glass jar
- Plankton net
- Refractometer
- Sampling data sheet
- Thermometer

AIR TEMPERATURE

- Hold the top of the thermometer for one minute.
- Record the temperature. If there is a weather station at your location, please refer to station data.

WIND

- Use the wind scale located on the data sheet to record how strong the wind is blowing. If there is a weather station at your location, please refer to station data.

TIDE

- Look at a local tide chart to determine what the tide level was at the time the plankton sample was taken.
- Record the time, date, and sample location.

WHOLE-WATER COLLECTION

- Use the bucket to collect a whole water surface sample.
- Place the thermometer in the bucket of water for one minute. Record the temperature.
- Place a few drops of whole water in the viewing chamber of the refractometer. Close the viewing chamber. Look through the eye piece to find where the blue and white colors meet. This color intersect will give you the salinity value.
- Fill the 2-liter plastic bottle (for cell counts, toxin, nutrients, and chlorophyll samples).
- Rinse the bucket, thermometer, and refractometer with fresh water after each sampling event.

VERTICAL NET-TOW COLLECTION

- Let the net drop near the bottom. Pull up at steady pace (about 1 m/second) and note the depth of sample by counting the meter marks on the net tow line.
- Pull net through water column up to three times. If color is seen after the first or second tow, stop. Note total distance (meters) net was towed (i.e., three tows at 4 m each equals total distance of 12 m).
- Swirl to mix the concentrated plankton sample in the cod end before pouring into the glass jar.
- Clean the net by rinsing it in fresh water. Hang the net up to dry, out of direct sunlight.

SOUNDTOXINS SAMPLE PROCESSING PROTOCOL

Lab Supplies

- Net tow sample
- Whole water sample
- Forceps
- Formaldehyde fixative
- Pipette
- Palmer-Maloney slide
- Scintillation vials
- GF/F filters
- Glass test tube
- Swinnex filter holder
- Syringe
- Graduated cylinder
- Plastic bottle
- Aluminum foil
- Pump
- Filter flask
- Filter cup
- Centrifuge tube
- 47 mm Millipore HA filters

Net Tow Processing

PHYTOPLANKTON SAMPLE

(species composition, relative abundance)

- Invert live net tow sample gently to mix. Pipette 0.1 ml into Palmer-Maloney cell.
- Record relative abundances of species on data sheet.

SPECIES COMPOSITION, RELATIVE ABUNDANCE

(sample archive)

- Invert live net tow sample to mix and pour an aliquot into a 20-ml scintillation vial.
- Add 1 ml formaldehyde fixative, cap, and invert to mix.
- Label cap with site name, date, and “NET”.
- Store vials in tray.

Use net tow sample to count *Alexandrium* and *Dinophysis*. Report any *Alexandrium* found. The first time *Dinophysis* appears in your sample, please report to soundtox@uw.edu as well as in your database entry. From then on report if the amount of *Dinophysis* observed increases from the prior week.

Whole-Water Processing

PHYTOPLANKTON SAMPLE

- Invert 2-liter bottle to mix. Pipette 0.1 ml into Palmer-Maloney cell.

Use the whole-water sample to count *Heterosigma* levels. Report any *Heterosigma* found in your sample to soundtox@uw.edu and in your database entry.

10X PHYTOPLANKTON SAMPLE

(sample archive)

- Invert 2-liter bottle to mix and pour a 50 ml aliquot into the glass test tube.
- Add 1 ml formaldehyde fixative, cap, invert to mix.
- After 24 hours or more of settling without disturbance, carefully aspirate off the top 45 ml of liquid using a pipette. Do not disturb the bottom.
- Transfer the remaining 5 ml of sample to a 20-ml scintillation vial.
- Label with site name, date, and “WW 10x.”

Use the whole-water 10x sample to count *Pseudo-nitzschia* levels. If the large-celled species (*Pseudo-nitzschia australis*, *P. heimii*, *P. fraudulenta*, *P. pungens*, *P. multiseries*=a/h/f/p/m) exceed 50,000 cells/L or if the small cells (*P. pseudodelicatissima*, *P. delicatissima*, *P. cuspidata*=pd/d/c) exceed 1 million cells/L, please report to soundtox@uw.edu and in your database entry.

Site-Specific Processing

CHLOROPHYLL/NUTRIENT SAMPLE

- Using forceps, place GF/F filter into Swinnex filter holder and tighten parts together. Make sure filter does not get bunched up in threads.
- Take plunger out of syringe and screw Swinnex filter holder onto end of syringe.
- Invert 2-liter bottle of whole water to mix.
- Measure 50 ml whole water from 2-liter bottle with graduated cylinder (or pour water into syringe up to the 50 cc line).
- Rinse nutrient bottle/tube by using plunger. Filter a small amount of water into numbered plastic bottle/tube to rinse. Repeat rinse step two more times.
- Filter remaining water into numbered plastic bottle/tube for nutrient sample (bottle/tube should be no more than 1/2 to 3/4 full).
- Record nutrient bottle number and the amount of water filtered into the database.
- Place nutrient sample bottle/tube upright in freezer. After frozen, samples can be placed in large plastic bags labeled with site name, approximate date range, and “NUTRIENTS.”
- Remove GF/F filter from Swinnex holder using forceps, fold filter in half with plankton on the inside, place in a square of aluminum foil, and fold into a packet.
- Label with site name, date, and “CHL” to indicate chlorophyll.
- Put foil packet in plastic bag labeled with site name, approximate date range, and “CHLOROPHYLL”.

- Store in freezer. Extracted chlorophyll filters are shown to have high stability for three months (Wasmund et al. 2006). Water for nutrient analysis may be processed within one year of collection. Nutrient samples are shown to have the following percent difference values (versus freshly analyzed samples) per Macdonald & McLaughlin (1982): phosphate 2–7%, nitrate 1.5–3%, silicic acid 0.9–1.7%.

PARTICULATE TOXIN SAMPLE (CELLULAR TOXIN)

- Set up pump, filtering flask, and filter cup with 47 mm Millipore HA filter (be sure to remove the blue paper between the filters).
- Gently invert 2-liter bottle to mix.
- Measure 1-liter of water with graduated cylinder and pour into filter cup to filter. Keep adding water to filter cup until entire 1-liter is filtered. If phytoplankton is dense and filtering is slow, you may use up to 3 HA filters for this sample.
- With forceps, remove filter, fold in half, and place all filters into an aluminum foil packet.
- Record the volume of water filtered in the database.
- Label foil with site name, date, and “pTOX” to indicate particulate toxin.
- Put foil packet in plastic bag labeled with site name, approximate date range, and “pTOX”.
- Store in freezer. When high numbers of *Alexandrium* or *Pseudo-nitzschia* are reported, filters may be analyzed within 1 month. Other samples preceding or following these HAB events may be analyzed within 1 months to a year to determine the timing of maximum toxin levels associated with the outbreak. Particulate domoic acid stored at –20°C is stable for up to 1 year, with less than 20% degradation. Ideally, however, stored samples should be analyzed within 2 months. Filters and dissolved extracts may be analyzed for saxitoxins using the method described in Lefebvre et al. (2008). Storage of samples containing saxitoxins at –20°C show stability for 6 months with ~20% loss at 1 year (Alfonso et al. 1994).

DISSOLVED TOXIN SAMPLE (TOXIN IN SEA WATER)

- Pipette 1–2 ml of filtered water from filtering flask into small yellow centrifuge tube.
- Label tube with site name, date, and “dTOX” to indicate dissolved toxin.
- Place in storage box labeled with site name, appropriate date range, and “dTOX.”
- Store in freezer. Dissolved domoic acid is stable for one year at –20°C with no detectable degradation (Baugh et al. 2005). Saxitoxins are water-soluble and very heat-stable, and so are not destroyed by cooking shellfish that contain them. Filters and dissolved extracts may be analyzed for saxitoxins using the method described in Lefebvre et al. (2008). Samples containing saxitoxins stored at –20°C show stability for 6 months with ~20% loss at 1 year (Alfonso et al. 1994).

CLEANING LAB GLASSWARE AND SAMPLING GEAR

- Rinse all lab glassware and sampling gear three times with freshwater.
- Set out to air-dry

REFERENCES

- Alfonso, A., Louzao, M.C., Vieytes, M.R., Botana, L.M. 1994. Comparative study of the stability of saxitoxin and neo-saxitoxin in acidic solutions and lyophilized samples. *Toxicol.* 32(2):1593-1598.
- Lefebvre, K.A., Bill, B.D., Erickson, A., Baugh, K.A., O'Rourke, L., Costa, P.R., Nance, S. and V.L. Trainer. 2008. Characterization of dissolved and particulate saxitoxin levels in both field and cultured *Alexandrium* samples from Sequim Bay, WA. *Marine Drugs* 6:103-116.
- Macdonald, R.W., McLaughlin, F.A. 1982. The effect of storage by freezing on dissolved inorganic phosphate, nitrate and reactive silicate for samples from coastal and estuarine waters. *Water Research* 16:95-104.
- Wasmund, N., Topp, I., Schories, D. 2006. Optimising the storage and extraction of chlorophyll samples. *Oceanologia* 48(1):125-144.

SoundToxins Data Entry Protocol

The SoundToxins application allows users to view/enter sampling event and species data. Each sampling event is considered a visit (date/time, water temperature, etc.). Every visit can be associated with multiple genera/species observations data (cell count, relative abundance, etc.).

SoundToxins data is observed on a weekly basis to track when and where harmful algal bloom species are occurring.

Below are the steps to enter data in the application.

LOGIN

- Go to www.soundtoxins.org.
- Click Data.
- Enter Username/Password.
- Click-on Login.

To request a password, send email to soundtox@uw.edu. A username and a temporary password will be emailed to your email address on file. The email will contain a link that will allow you to change your temporary password.

SITES

A list of sampling sites is displayed along with a map of where the sites are located. The sites that you have permission to enter data for have a **visits** button to the left of the site name. If you do not see a **visits** button on any site, that means you only have view permissions for the application (meaning you can only see the data but not modify it).

For entering data purposes, click on the **visits** button of the site where you want to enter data.

VISITS

A list of visits will be displayed for the chosen site. Each sampling event corresponds to a visit.

CREATING A NEW VISIT

- Click the yellow “New Visit” button.
- Enter the visit data.
- Click the “Create” button on the upper right region of the page.
Once a visit is created, you will be able to enter genus/species observation associated to the particular visit. The four required genera will now be visible in the Required Observations region at the bottom (covered later). For additional genera/species observations, click the “Additional Observations” button at the bottom right (covered later).

EDITING AN EXISTING VISIT

- Click on the **visits** button of your site that you wish to edit.
- Click on the **visits** button to the left of the visit name.
- Make any changes to the visit data.
- Click the “Save” button on top right region of the page. NOTE: always click “Save” before navigating to another page to ensure that the data you entered was properly recorded.

REQUIRED OBSERVATIONS

The Visit page (explained above) will also allow you to select “Species, Relative Abundance” and enter comments for the four main genera (*Pseudo-nitzschia*, *Alexandrium*, *Dinophysis* and *Heterosigma*). Please do not modify the genus field for the main observations.

ENTERING HIGH-LEVEL DATA FOR REQUIRED OBSERVATIONS

- Select “Species, Relative Abundance” and enter comments for the main observations.
- Click “Save.”

ENTERING DETAILED DATA/COUNTS FOR REQUIRED OBSERVATIONS

- Click the “Add Cell Counts” link to the right of the Comments field.
- Enter the detailed data for the main observation.
- Click “Save.”

ADDITIONAL OBSERVATIONS

When clicking the “Additional Observations” button on the Visit page, you are taken to a page that displays a list of non-main genera/species associated with the chosen site. The page also allows you to add/associate multiple genera/species to the chosen site.

ADDING NEW GENUS/SPECIES

- Click “Add Species.”
- Select “Genus,” “Species” (if possible), and “Relative Abundance” and enter comments for the additional observations.

ENTERING DETAILED DATA/COUNTS FOR ADDITIONAL OBSERVATIONS

- Click the “Add Cell Counts” link to the right of the Comments field.
- Enter the detailed data for the main observation.
- Click “Save.”

VIEWING DATA FROM OTHER SAMPLED LOCATIONS

- Click on the site you wish to view.
- Click on the date for which you would like to view data.

LOGGING OUT

- Click “Log Out” in the top right corner of the site.

If there are any problems on the site, contact soundtox@uw.edu.

DATA SECURITY

These data are managed and viewed only by SoundToxins volunteers and staff. You need to change your password every 3 months. If you do not change it ahead of time, the system will lock you out. Contact soundtox@uw.edu if you are locked out of the system.

HOW TO CALCULATE THE VOLUME OF WATER FILTERED THROUGH THE NET

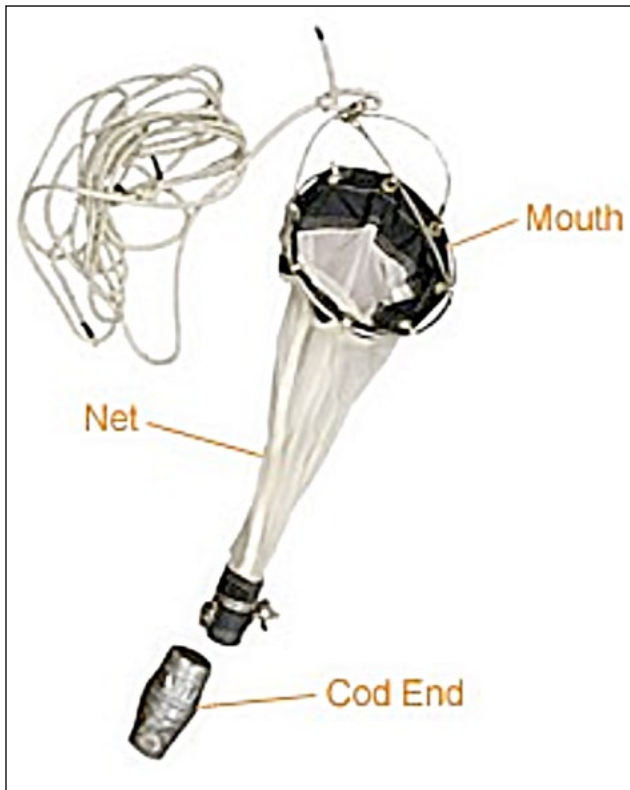

To calculate volume of water filtered through the net, you will need to know the tow length, how many times you towed your net, and net mouth diameter.

Net mouth diameter = 25 cm = 0.25 m

Some nets have different mouth diameters. Measure your net to be sure and adjust the calculations, if necessary.

Radius (r) = 0.25 m / 2 = 0.125 m

Area of mouth = $\pi r^2 = 3.14 \times 0.125^2 = 0.049 \text{ m}^2$

Area of mouth of net x length of net tow = total volume filtered

Example: You tow your net 2 times through 5 m of water, so the total length of net tow is $2 \times 5 \text{ m} = 10 \text{ m}$. Area of mouth is 0.049 m^2 .

Total volume filtered = $0.049 \text{ m}^2 \times 10 \text{ m} = 0.49 \text{ m}^3$. Convert m^3 to liters ($1 \text{ m}^3 = 1,000 \text{ L}$). Total volume filtered in L = $0.49 \text{ m}^3 \times 1,000 \text{ L} = 490 \text{ L}$

Record total volume filtered on count sheet and use it to calculate semi-quantitative cell counts from net tow material.

HOW TO CALCULATE SEMI-QUANTITATIVE CELL CONCENTRATION FROM NET TOW MATERIAL

To calculate the amount of cells harvested in your plankton tow you will need to know the volume of water filtered and the number of cells counted.

Example: Total volume filtered was 490 L and cod end volume was 150 ml, or 0.15 L. Cell count from net tow was 250 cells/ml (or 250,000 cells/L in net tow).

Cell concentration (cells/L) / Total volume filtered (L) X Cod end volume (L) = Cell concentration in sampling site water (whole water).

$(250,000 \times 0.15) / 490 = 77 \text{ cells/L}$ in sampling site water (whole water)

HOW TO USE A PALMER-MALONEY SLIDE

Adapted from *A Taxonomic Guide to Some Common Marine Phytoplankton* by Rita A. Horner



This slide has a volume of 0.1 ml and a loading slot on each side.

To use:

- Put a cover slip (22 mm, No.1) over the plastic ring and tilt the slide slightly while holding the coverslip in place.
- With a pipette, add the 0.1 ml sample to the lower of the two loading slots.
- Be sure there are no bubbles.
- To count cells, make sure to start at one “corner” of the slide and then move the slide horizontally.

A slightly longer cover slip, 22x30mm, covers both loading slots and minimizes sample evaporation during counting.

This slide is thicker than a standard microscope slide and cover slip, but 40x objectives can be used with it.

RELATIVE ABUNDANCE EXAMPLES

To determine relative abundance, see if one or several particular species are more dominant than others. If so, use the examples below to categorize as “present,” “common,” “abundant,” or “bloom.” If the phytoplankton species seem uniform in low numbers, categorize as “pres-

ent.” For phytoplankton that you see only one of, also mark as “present.” This method applies to the net tow counts as well as the *Pseudo-nitzschia* counts using the 10x concentrated sample.

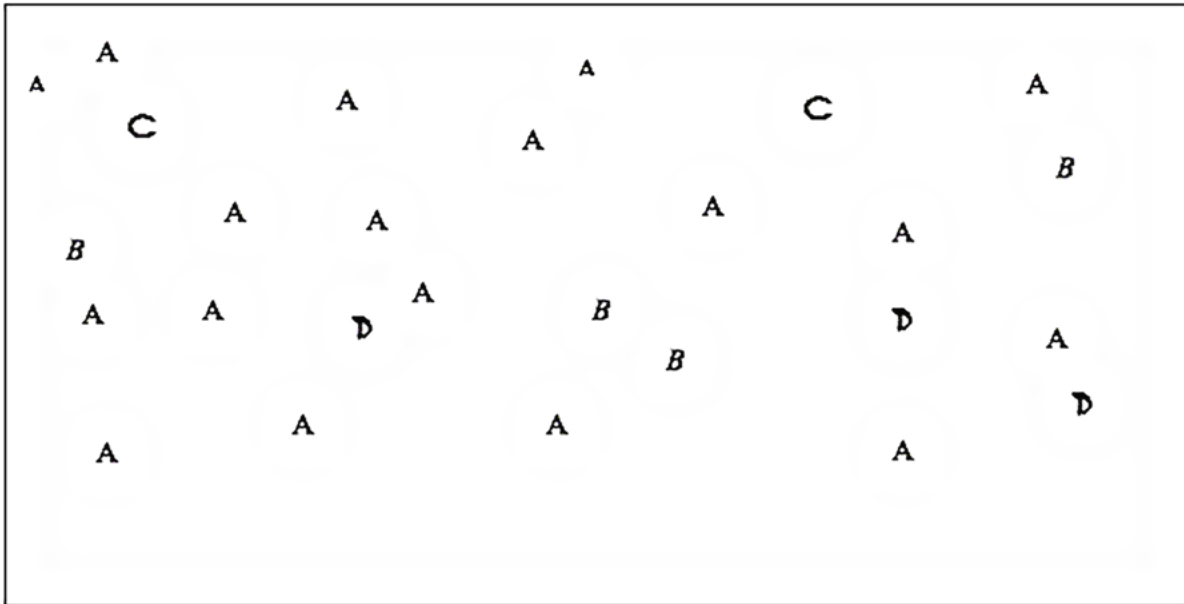

Bloom: Species A

Present: Species B, C, and D



Common: *Pseudo-nitzschia*

Present: *Ceratium*, *Thalassiosira*, *Chaetoceros*, *Ditylum*, *Skeletonema*, *Dactyliosolen*



Common: *Rhizosolenia*

Present: *Ditylum*, *Pseudo-nitzschia*, *Chaetoceros*, *Hemialus*

Appendices

Basic Morphological Terminology of Phytoplankton

BILOBED

Dinoflagellates –
divided into two lobes



FLAGELLA (p)

Dinoflagellates –
whip-like structures used
primarily for locomotion

Flagellum (s)

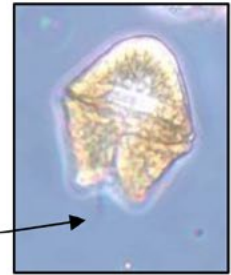

CENTRIC [Taxonomic Order]

Diatoms –
valve striae arranged in
relation to a point or central
areola; often round or circular

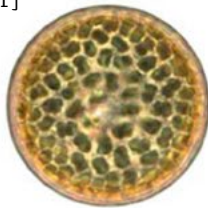

FRUSTULE

Diatoms –
siliceous parts of the cell wall
or skeleton

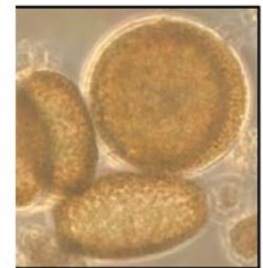

CHAIN

Phytoplankton –
of the same species linked
together



NUCLEUS

Phytoplankton –
organelle in eukaryotic cells containing most of the cell's
genetic material



PEDUNCLE

Heterotrophic Dinoflagellates –
mouth used for engulfing food

CHLOROPLASTS

Phytoplankton –
organelles in the
cytoplasm that
contain cell pigments



PENNATE [Taxonomic Order]

Diatoms –
longitudinally symmetric



EYESPOT

Dinoflagellates –
red spot involved in light perception

PLATED

Some Dinoflagellates –
armored plates composed of
cellulose found in the cell wall



PROCESS

Diatoms –
an oriented projection of a
silicate cell wall



STEPPED CHAIN

Diatoms –
organism linked together to
form a series of steps

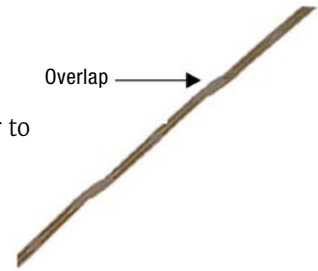

RAPHE

Pennate Diatoms –
longitudinal fissure associated
with and involved in gliding
locomotion

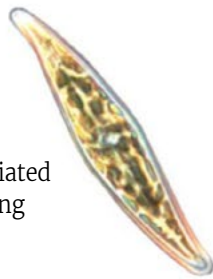

THECA

Dinoflagellates –
a multiple membrane complex with vesicles and some
species with scales, composed of cellulose

SEGMENTED

Diatoms –
separation of the main body into sections,
may be equal or unequal

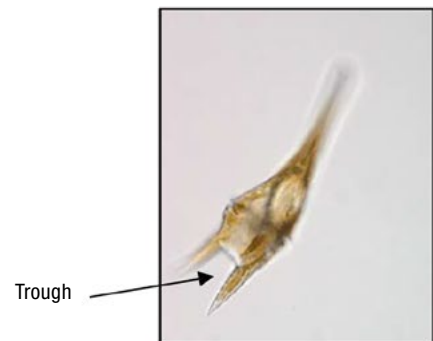

SPINES

Diatoms –
closed or solid
structures projecting
from the cell wall

Dinoflagellates –
solid protuberances
that usually taper to a point

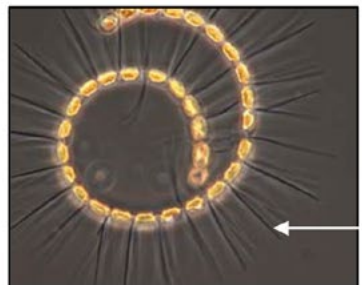

TROUGH

Dinoflagellates –
depression in the main body of the cell

Phytoplankton Monitoring Network

Promoting a better understanding of Harmful Algal Blooms by way of Volunteer Monitoring



SoundToxins Data Entry Sheet

Sample Collection Location: _____

Volunteer Name(s): _____

Sample Collection Date/Time: _____

Comments: _____

Weather

Condition (cloudy, mostly cloudy, partly cloudy, mostly clear, clear): _____

Wind (none, light, moderate, strong): _____

Tide (incoming, outgoing, high, low): _____

Air Temperature (°C): _____

Water

Water Temperature (°C): _____

Salinity (PPT): _____

Net Tow

Total Distance Towed (m): _____

Total Sample Volume from Cod End (mL): _____

Sample Processing

Date Processed	Volume Filtered (mL)		dTox	Nutrient Bottle #	Cells Preserved/Archived				
	pTox	Chlor			Net Tow	WW	WW 10X		

Cell Counts

Genus	Net Tow Relative Abundance N, P, C, B (none, present, common, bloom)	Cell Count Net Tow (Semi-quantitative) (cells/L)	Cell Count WW (cells/L)	Cell Count WW 10X (cells/L)
<i>Pseudo-nitzschia</i>				
<i>Alexandrium</i>				
<i>Dinophysis</i>				
<i>Heterosigma</i>				

<i>Pseudo-nitzschia</i> spp. size classification	% Small	% Large

<i>Dinophysis</i> spp. classification	%
<i>D. acuminata</i>	
<i>D. acuta</i>	
<i>D. fortii</i>	
<i>D. norvegica</i>	
<i>D. odiosa</i>	
<i>D. parva</i>	
<i>D. rotundata</i>	
<i>D. tripos</i>	

SoundToxins Phytoplankton Identification

Sample Site: _____
Name(s): _____

Sample Date: _____

Diatoms	Species (if known)	Abundance (P, C, B)	Dinoflagellates	Species (if known)	Abundance (P, C, B)	Other	Species (if known)	Abundance (P, C, B)
<i>Actinocyclus</i>			<i>Akashiwo</i>			<i>Dictyocha</i>		
<i>Asterionellopsis</i>			<i>Amylax</i>			<i>Ebria</i>		
<i>Asteromphalus</i>			<i>Azadinium</i>			<i>Phaeocystis</i>		
<i>Bacteriastrum</i>			<i>Ceratium</i>					
<i>Cerataulina</i>			<i>Dissodinium</i>					
<i>Chaetoceros</i>			<i>Gonyaulax</i>					
<i>Coscinodiscus</i>			<i>Gymnodinium</i>					
<i>Cylindrotheca</i>			<i>Gyrodinium</i>					
<i>Dactyliosolen</i>			<i>Heterocapsa</i>					
<i>Detonula</i>			<i>Lingulodinium</i>					
<i>Ditylum</i>			<i>Noctiluca</i>					
<i>Eucampia</i>			<i>Oxyphysis</i>					
<i>Guinardia</i>			<i>Polykrikos</i>					
<i>Hemiaulus</i>			<i>Prorocentrum</i>					
<i>Lauderia</i>			<i>Protoceratium</i>					
<i>Leptocylindrus</i>			<i>Protoperidinium</i>					
<i>Melosira</i>			<i>Scrippsiella</i>					
<i>Odontella</i>								
<i>Paralia</i>								
<i>Proboscia</i>								
<i>Pleurosigma/Gyrosigma</i>								
<i>Rhizosolenia</i>								
<i>Skeletonema</i>								
<i>Stephanopyxis</i>								
<i>Striatella</i>								
<i>Thalassionema</i>								
<i>Thalassiosira</i>								
<i>Tropidoneis</i>								

This identification card includes most groups of marine zooplankton found in Puget Sound. Size ranges provided are approximate - some specimens may be outside of the stated ranges. Exact measurements for specimens in photos are provided where available.

Marine Zooplankton of Puget Sound



Copepods 0.5-5 mm

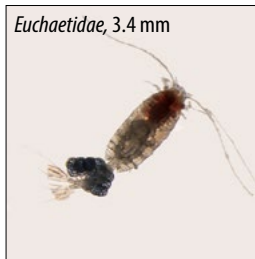
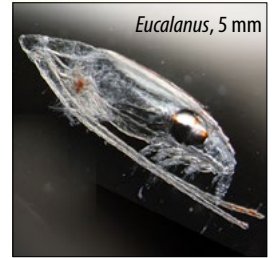
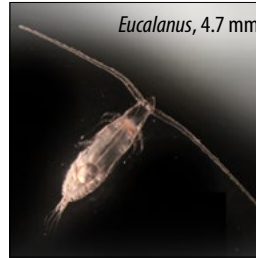
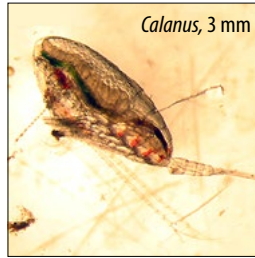
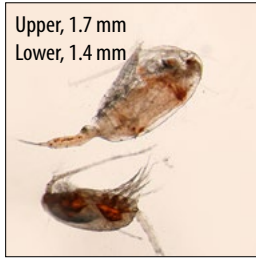

Cladocerans (water fleas) ~1 mm



Amphipods 0.5-2 mm

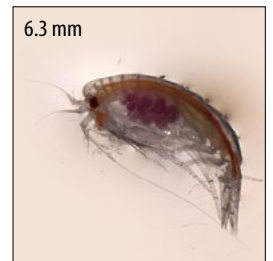
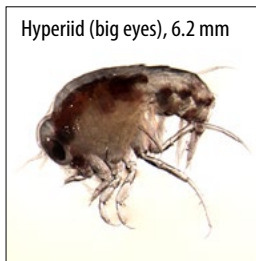
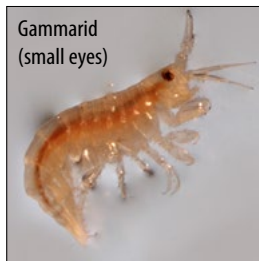

Ostracods 0.5-2 mm



Crab larvae 2-5 mm

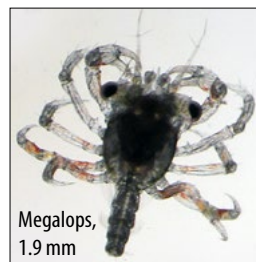

Pagurus larvae 1-4 mm

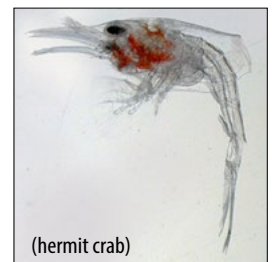

Euphausiids (krill) nauplius ~ 0.5 mm; calyptopis 0.5 mm-1.5 mm; furcilia 2-5 mm; adults 8-15 mm

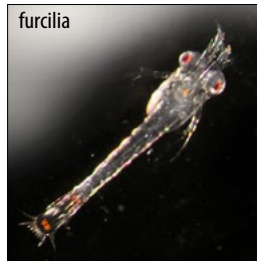
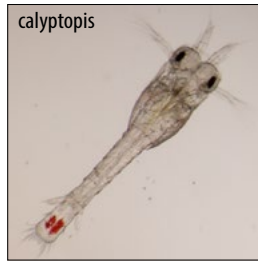
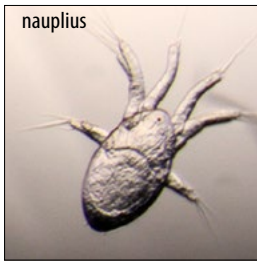

All photos by Audrey Djunaedi, except *Calanus* provided by Julie Keister; larvacean provided by NOAA Photo Library; fish larva provided by Sarah Norberg, NWFSC, NOAA. Special thanks to Julie Keister and Audrey Djunaedi for advising on content and providing size information.

Barnacles (larvae and adult molt) larvae 0.5-1 mm; molt size varies

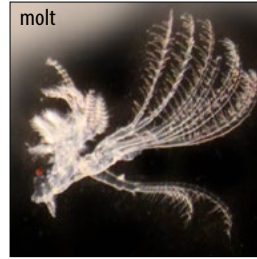
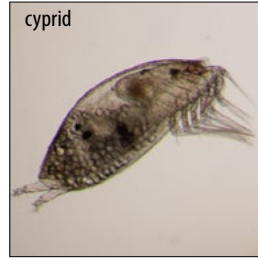
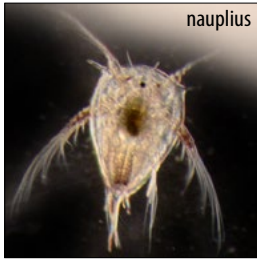

Washington Sea Grant
University of Washington
3716 Brooklyn Avenue NE
Seattle, WA 98105-6716
206.543.6600
WSG-AS 13-07
www.wsg.washington.edu

Jellies

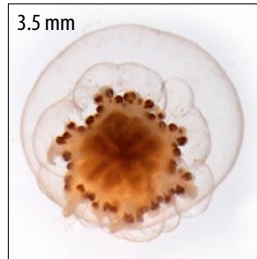
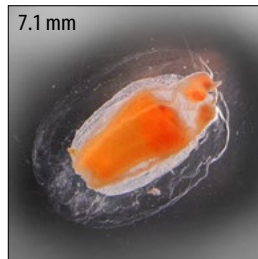

Siphonophores 4-8+ mm

Ctenophores

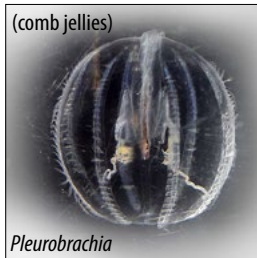

Polychaete worms 1 mm-50 cm

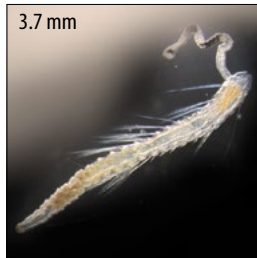

Chaetognaths (arrow worms) 3-40 mm



Pteropods 0.1-3 mm



Gastropod larvae 0.1-0.8 mm

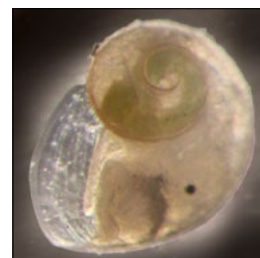

Octopus larvae 3-10 mm **Cyphonautes** height ~0.6 mm

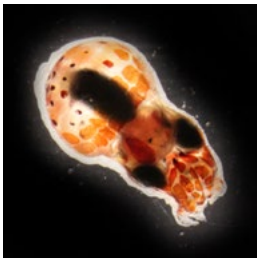

Larvaceans 2-4 mm



Fish larvae





Washington Sea Grant
University of Washington
3716 Brooklyn Ave. N.E.
Box 355060
Seattle, WA 98105-6716

206.543.6600

wsg.washington.edu

seagrants@uw.edu
