



1
2
3
4
5

Document Identifier: DSP1046

Date: 2020-05-18

Version: 1.0.0

6 **Network Management Profile**

- 7 **Supersedes: None**
- 8 **Document Class: Normative**
- 9 **Document Status: Published**
- 10 **Document Language: en-US**

11 Copyright Notice

12 Copyright © 2013-2020 DMTF. All rights reserved.

13 DMTF is a not-for-profit association of industry members dedicated to promoting enterprise and systems
14 management and interoperability. Members and non-members may reproduce DMTF specifications and
15 documents, provided that correct attribution is given. As DMTF specifications may be revised from time to
16 time, the particular version and release date should always be noted.

17 Implementation of certain elements of this standard or proposed standard may be subject to third party
18 patent rights, including provisional patent rights (herein "patent rights"). DMTF makes no representations
19 to users of the standard as to the existence of such rights, and is not responsible to recognize, disclose,
20 or identify any or all such third party patent right, owners or claimants, nor for any incomplete or
21 inaccurate identification or disclosure of such rights, owners or claimants. DMTF shall have no liability to
22 any party, in any manner or circumstance, under any legal theory whatsoever, for failure to recognize,
23 disclose, or identify any such third party patent rights, or for such party's reliance on the standard or
24 incorporation thereof in its product, protocols or testing procedures. DMTF shall have no liability to any
25 party implementing such standard, whether such implementation is foreseeable or not, nor to any patent
26 owner or claimant, and shall have no liability or responsibility for costs or losses incurred if a standard is
27 withdrawn or modified after publication, and shall be indemnified and held harmless by any party
28 implementing the standard from any and all claims of infringement by a patent owner for such
29 implementations.

30 For information about patents held by third-parties which have notified the DMTF that, in their opinion,
31 such patent may relate to or impact implementations of DMTF standards, visit
32 <http://www.dmtf.org/about/policies/disclosures.php>.

33 This document's normative language is English. Translation into other languages is permitted.

CONTENTS

35	Foreword	6
36	Introduction.....	7
37	1 Scope	9
38	2 Normative references	9
39	3 Terms and definitions	9
40	4 Symbols and abbreviated terms	11
41	5 Synopsis	11
42	6 Description	13
43	6.1 Class diagram	13
44	7 Implementation requirements.....	16
45	7.1 Representing the Network Management Service	16
46	7.2 Representing the Network Management Service Capabilities	16
47	7.3 Representing the Network	16
48	7.3.1 CIM_Network	16
49	7.3.2 Networks contained within a network	16
50	7.3.3 Network dependency	17
51	7.4 Representation of network ports	17
52	7.4.1 CIM_NetworkPort.....	17
53	7.4.2 CIM_LogicalPortGroup	17
54	7.5 Representation of collections of protocol endpoints	17
55	7.5.1 CIM_LANConnectivitySegment	17
56	7.5.2 CIM_IPConnectivitySubnet.....	17
57	7.5.3 CIM_NetworkVLAN.....	18
58	7.6 Representation of protocol endpoints.....	18
59	7.6.1 CIM_LANEndpoint	18
60	7.6.2 CIM_IPProtocolEndpoint	18
61	7.6.3 CIM_VLANEndpoint.....	18
62	7.7 CIM_NetworkSettingData	19
63	7.8 CIM_EthernetPortAllocationSettingData.....	19
64	8 Methods.....	19
65	8.1 Profile conventions for operations	19
66	8.2 CIM_NetworkManagementService	20
67	8.3 CIM_NetworkManagementServiceCapabilities	20
68	8.4 CIM_NetworkPolicyService	20
69	8.5 CIM_RedundancySet.....	20
70	8.6 CIM_Network	20
71	8.7 CIM_VLANNetwork.....	20
72	8.8 CIM_NetworkCapabilities	20
73	8.9 CIM_NetworkSettingData	20
74	8.10 CIM_EthernetPortAllocationSettingData.....	20
75	8.11 CIM_NetworkPort.....	20
76	8.12 CIM_EthernetPort	20
77	8.13 CIM_LogicalPortGroup	20
78	8.14 CIM_System	20
79	8.15 CIM_ConnectivityCollection	20
80	8.16 CIM_LANConnectivitySegment	21
81	8.17 CIM_LANEndpoint	21
82	8.18 CIM_IPConnectivitySubnet.....	21
83	8.19 CIM_IPProtocolEndpoint	21
84	8.20 CIM_NetworkVLAN.....	21
85	8.21 CIM_VLANEndpoint.....	21
86	8.22 CIM_RegisteredProfile.....	21

87	8.23	CIM_ElementConformsToProfile	21
88	8.24	CIM_HostedService	21
89	8.25	CIM_ElementCapabilities	21
90	8.26	CIM_ServiceAffectsElement	21
91	8.27	CIM_ContainedNetwork.....	21
92	8.28	CIM_MemberOfCollection	21
93	8.29	CIM_HostedCollection	21
94	8.30	CIM_Dependency	22
95	8.31	CIM_PeerNetwork.....	22
96	8.32	CIM_ElementSettingData	22
97	8.33	CIM_SystemComponent.....	22
98	8.34	CIM_SettingsDefineCapabilities	22
99	8.35	CIM_SystemDevice	22
100	8.36	CIM_DeviceConnection	22
101	8.37	CIM_ActiveConnection	22
102	8.38	CIM_DeviceSAPImplementation	22
103	9	Use cases.....	23
104	9.1	Miscellaneous object diagrams.....	23
105	9.2	Representing VLAN networks within an L2 network.....	24
106	9.3	Representing underlay IP networks within an L2 overlay network	25
107	9.4	Representing two peer IP networks.....	26
108	9.5	Representing two tenant networks within a provider network	27
109	9.6	Representing ethernet ports of tenant networks.....	28
110	9.7	Representing systems connected to ethernet ports of tenant networks.....	29
111	9.8	Representing a tunneled network connecting two ethernet networks	30
112	9.9	Enumerate networks	30
113	9.10	Enumerate contained networks within a specific network	30
114	9.11	Create one or more networks	30
115	9.12	Create one or more networks within a network	30
116	9.13	Delete a network.....	31
117	9.14	Discover logical ports of a network	31
118	9.15	Discover logical port groups of a network.....	31
119	9.16	Discover IP subnets of a network	31
120	9.17	Discover VLANs of a network	31
121	9.18	Discover L2 segments of a network.....	31
122	9.19	Discover systems within a network.....	31
123	9.20	Enumerate networks that a system is directly connected to (intrinsic method).....	31
124	10	CIM Elements.....	32
125	ANNEX A (informative)	Change log.....	34

126

127 **Figures**

128	Figure 1 – Network Management Profile: Class diagram	14
129	Figure 2 – Registered profile.....	23
130	Figure 3 – Two VLAN networks within a Layer 2 network	24
131	Figure 4 – Two IPv4 underlay networks creating a layer 2 overlay network	25
132	Figure 5 – Two peer managed networks	26
133	Figure 6 – Two tenant networks within a provider network.....	27
134	Figure 7 – Representing ethernet ports of two tenant networks within a provider	28
135	Figure 8 – Representing systems connected to ethernet ports of two tenant networks within a provider	29
136	network.....	29
137	Figure 9 – Representing a tunneled network bridging two ethernet networks.....	30
138		

139 **Tables**

140 Table 1 – Referenced profiles 12
141 Table 2 – CIM Elements: Network Services Management Profile 32
142

143

Foreword

144 The *Network Management Profile* (DSP1046) was prepared by the Network Services Management
145 Working Group of the DMTF.

146 DMTF is a not-for-profit association of industry members dedicated to promoting enterprise and systems
147 management and interoperability.

148 Acknowledgments

149 The DMTF acknowledges the following individuals for their contributions to this document:

150 Editors:

- 151 • Hemal Shah – Broadcom Corporation
- 152 • Alex Zhdankin – Cisco Systems

153 Contributors:

- 154 • Steve Neely – Cisco Systems
- 155 • Shishir Pardikar – Citrix
- 156 • Eric Wels - Hitachi
- 157 • John Parchem – Microsoft Corporation
- 158 • Lawrence Lamers – VMware
- 159 • Bhumip Khasnabish – ZTE

160

161

162

Introduction

163 The information in this specification should be sufficient for a provider or consumer of this data to identify
164 unambiguously the classes, properties, methods, and values that shall be instantiated and manipulated to
165 represent and manage Network Services and the associated configuration information. The target
166 audience for this specification is implementers who are writing CIM-based providers or consumers of
167 management interfaces that represent the component described in this document.

168 **Document conventions**

169 **Typographical conventions**

170 The following typographical conventions are used in this document:

- 171 • Document titles are marked in *italics*.
- 172 • ABNF rules are in `monospaced font`.

173

175

Network Management Profile

176 1 Scope

177 The *Network Management Profile* is a base profile that specifies the CIM schema and use cases
178 associated with the common aspects of the Network and Network Services management. This profile
179 includes a specification of the Network Management Service, Network, Network Ports, Protocol Endpoints
180 and other classes necessary for representing the basic connectivity and administrative aspects of the
181 Network.

182 2 Normative references

183 The following referenced documents are indispensable for the application of this document. For dated or
184 versioned references, only the edition cited (including any corrigenda or DMTF update versions) applies.
185 For references without a date or version, the latest published edition of the referenced document
186 (including any corrigenda or DMTF update versions) applies.

187 DMTF DSP0004, *CIM Infrastructure Specification 2.6*,
188 https://www.dmtf.org/standards/documents/DSP0004_2.6.0_0.pdf

189 DMTF DSP0200, *CIM Operations over HTTP 1.3*,
190 http://www.dmtf.org/standards/documents/DSP0200_1.3.pdf

191 DMTF DSP0223, *Generic Operations 1.0*,
192 https://www.dmtf.org/standards/documents/DSP0223_1.0.2.pdf

193 DMTF DSP1001, *Management Profile Specification Usage Guide 1.0*,
194 http://www.dmtf.org/standards/documents/DSP1001_1.0.pdf

195 DMTF DSP1014, *Ethernet Port Profile 1.0*,
196 https://www.dmtf.org/standards/documents/DSP1014_1.0.1.pdf

197 DMTF DSP1116, *IP Configuration Profile 1.0*,
198 http://www.dmtf.org/standards/documents/DSP1116_1.0.pdf

199 DMTF DSP1033, *Profile Registration Profile 1.0*,
200 http://www.dmtf.org/standards/documents/DSP1033_1.0.pdf

201 DMTF DSP1048, *Network Policy Management Profile 1.0*,
202 http://www.dmtf.org/standards/documents/DSP1048_1.0.pdf

203 ISO/IEC Directives, Part 2, *Rules for the structure and drafting of International Standards*,
204 <http://isotc.iso.org/livelink/livelink.exe?func=ll&objId=4230456&objAction=browse&sort=subtype>

205 3 Terms and definitions

206 In this document, some terms have a specific meaning beyond the normal English meaning. Those terms
207 are defined in this clause.

208 The terms "shall" ("required"), "shall not", "should" ("recommended"), "should not" ("not recommended"),
209 "may," "need not" ("not required"), "can" and "cannot" in this document are to be interpreted as described
210 in [ISO/IEC Directives, Part 2](#), Clause 7. The terms in parenthesis are alternatives for the preceding term,
211 for use in exceptional cases when the preceding term cannot be used for linguistic reasons. Note that
212 [ISO/IEC Directives, Part 2](#), Clause 7 specifies additional alternatives. Occurrences of such additional
213 alternatives shall be interpreted in their normal English meaning.

214 The terms "clause", "subclause", "paragraph", and "annex" in this document are to be interpreted as
215 described in [ISO/IEC Directives, Part 2](#), Clause 6.

216 The terms "normative" and "informative" in this document are to be interpreted as described in [ISO/IEC](#)
217 [Directives, Part 2](#), Clause 3. In this document, clauses, subclauses, or annexes labeled "(informative)" do
218 not contain normative content. Notes and examples are always informative elements.

219 The terms defined in [DSP0004](#), [DSP0223](#), and [DSP1001](#) apply to this document. The following additional
220 terms are used in this document.

221 **3.1**
222 **conditional**

223 indicates requirements to be followed strictly to conform to the document when the specified conditions
224 are met

225 **3.2**
226 **mandatory**

227 indicates requirements to be followed strictly to conform to the document and from which no deviation is
228 permitted

229 **3.3**
230 **optional**

231 indicates a course of action permissible within the limits of the document

232 **3.4**
233 **pending configuration**

234 indicates the configuration that will be applied to an IP network connection the next time the IP network
235 connection accepts a configuration

236 **3.5**
237 **referencing profile**

238 indicates a profile that owns the definition of this class and can include a reference to this profile in its
239 "Referenced Profiles" table

240 **3.6**
241 **unspecified**

242 indicates that this profile does not define any constraints for the referenced CIM element or operation

243 **3.7**
244 **Network**

245 The term Network in this specification applies to a logical, virtual, or physical network that is managed as
246 an independent entity or an entity contained within another network, or an entity that is a peer to other
247 networks.

248 **3.8**
249 **VLAN Network**

250 A VLAN Network is a specific type of network representing a Virtual LAN.

251 **3.9**
252 **Contained Network**

253 A Contained Network is a specific type of network that is contained within another network. One or more
254 contained networks are aggregated by the containing network.

255 **3.10**
256 **Containing Network**

257 A Containing Network is a specific type of network that contains one or more networks. The containing
258 network aggregates one or more contained networks.

259 **3.11**
260 **Dependent Network**

261 A Dependent Network is a specific type of network whose existence depends on another network.

262 **3.12**
263 **Network Port**

264 A Network Port represents a managed entity for communication within a network.

265 **3.13**
266 **Network Port Group**

267 A Network Port Group represents a collection of network ports.

268 **3.14**
269 **Network Service**

270 A Network Service represents an operational function of a network. For example, DHCP Service in an IP
271 network.

272 **4 Symbols and abbreviated terms**

273 The abbreviations defined in [DSP0004](#), [DSP0223](#), and [DSP1001](#) apply to this document. The following
274 additional abbreviations are used in this document.

275 **4.1**
276 **IP**
277 Internet Protocol

278 **4.2**
279 **VLAN**
280 Virtual Local Area Network

281 **5 Synopsis**

282 **Profile name:** Network Management Profile

283 **Version:** 1.0.0

284 **Organization:** DMTF

285 **CIM Schema version:** 2.53

286 **Central class:** CIM_NetworkManagementService

287 **Scoping class:** CIM_System (HostingSystem)

288 The *Network Management Profile* is a base profile that specifies the CIM schema and use cases
289 associated with the common aspects of the Network and Network Services management. This profile
290 includes a specification of the Network Management Service, Network, Network Ports, Protocol Endpoints
291 and other classes necessary for representing the basic connectivity and administrative aspects of the
292 Networks and Network Services.

293 Table 1 identifies profiles on which this profile has a dependency.

294

Table 1 – Referenced profiles

Profile Name	Organization	Version	Requirement	Description
Profile Registration	DMTF	1.0	Mandatory	See DSP1033
Ethernet Port	DMTF	1.0	Optional	See DSP1014
Network Policy Management	DMTF	1.0	Optional	See DSP1048

295 6 Description

296 The *Network Management Profile* describes the common aspects of the Network management. This
297 profile includes a specification of the Network Management Service, Network, Network Ports, Protocol
298 Endpoints and other classes necessary for representing the basic connectivity and administrative aspects
299 of the Network.

300 This profile enables many aspects of network management including but not limited to:

- 301 • Network topology discovery
- 302 • Network capabilities discovery
- 303 • Network monitoring and statistics collection
- 304 • Network configuration and control
- 305 • Network view (a snapshot of network)
- 306 • Network resources (ports, protocol endpoints, port groups, etc.) inventory
- 307 • Network resources configuration and control

308 The information in this specification should be sufficient for a provider or consumer of this data to identify
309 unambiguously the classes, properties, methods, and values that must be instantiated and manipulated to
310 represent and manage the networks and network resources modeled using the DMTF CIM core and
311 extended model definitions.

312 6.1 Class diagram

313 Figure 1 represents the class schema for the *Network Management Profile*. For simplicity, the CIM_ prefix
314 has been removed from the names of the classes.

315

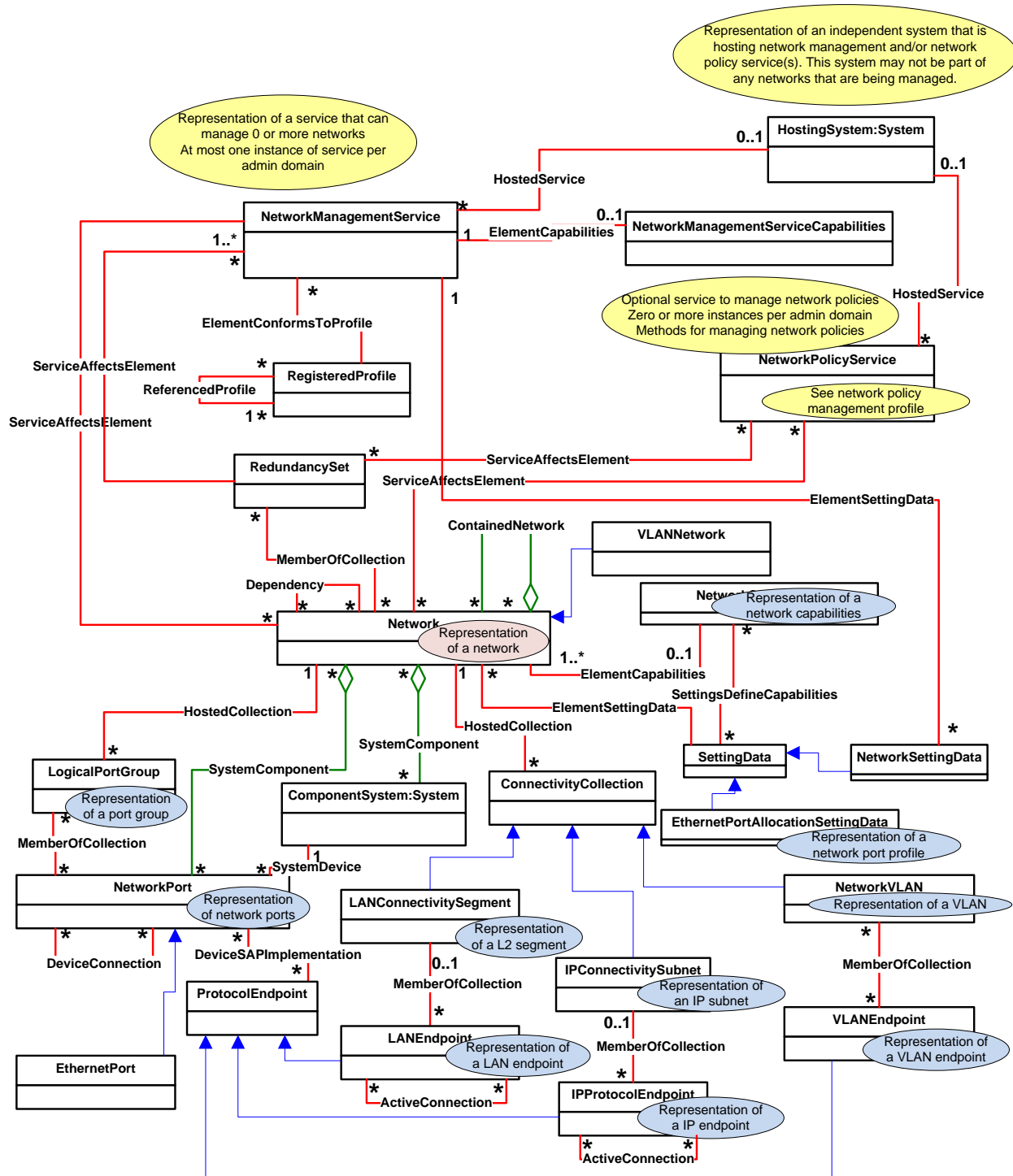

316

317

Figure 1 – Network Management Profile: Class diagram

318 CIM_NetworkManagementService is the central class. CIM_NetworkManagementService represents the
 319 service that is managing networks represented by CIM_Network. CIM_NetworkManagementService class
 320 supports extrinsic methods for creation, deletion, and modification of networks and network resources.

321 CIM_HostingSystem represents the system hosting the network management service. This relationship
322 between CIM_HostingSystem and CIM_NetworkManagementService is represented by
323 CIM_HostedService. The capabilities of the network management service are described by
324 CIM_NetworkManagementServiceCapabilities. CIM_NetworkManagementServiceCapabilities class is
325 derived from the CIM_EnabledLogicalElementCapabilities class.
326 CIM_NetworkManagementServiceCapabilities is associated with CIM_NetworkManagementService
327 through CIM_ElementCapabilities. CIM_ServiceAffectsElement is used to represent the relationship
328 between the CIM_NetworkManagementService and the resources managed by
329 CIM_NetworkManagementService.

330 The CIM_Network class represents a logical, virtual, or physical network. CIM_Network supports a
331 representation of a network. A network can be an independent network or a network contained within
332 another network, or a network that is related to other networks. The relationship of a network contained
333 within a network is represented by CIM_ContainedNetwork. A VLAN network is represented by
334 CIM_VLANNetwork that is derived from CIM_Network. CIM_RedundancySet is used to model failover
335 and load balancing of networks.

336 The capabilities of a network are described by one or more instances of CIM_NetworkCapabilities.
337 CIM_NetworkCapabilities is derived from the CIM_EnabledLogicalElementCapabilities class.
338 CIM_NetworkCapabilities is associated with CIM_Network through CIM_ElementCapabilities.

339 The configuration of a network is described by one or more instances of the CIM_SettingData.
340 CIM_EthernetPortAllocationSettingData represents a network port profile. Network port profiles
341 provisioned on a network are represented by one or more instances of
342 CIM_EthernetPortAllocationSettingData. CIM_EthernetPortAllocationSettingData is derived from the
343 CIM_SettingData. CIM_SettingData is associated with Network through CIM_ElementSettingData.

344 The following network resources are represented.

- 345 1) CIM_NetworkPort represents a port of a network. CIM_NetworkPort is associated with
346 CIM_Network through CIM_SystemComponent. CIM_EthernetPort is a derived class of
347 CIM_NetworkPort that represents an Ethernet port. Connection between two CIM_NetworkPort
348 instances is represented by CIM_DeviceConnection.
- 349 2) CIM_ComponentSystem represents a system within a network. CIM_ComponentSystem is
350 associated with CIM_Network through CIM_SystemComponent. The relationship between
351 CIM_NetworkPort and CIM_ComponentSystem is represented by CIM_SystemDevice.
- 352 3) CIM_LogicalPortGroup represents a port group within a network. CIM_LogicalPortGroup is
353 associated with *Network* through CIM_HostedCollection.
- 354 4) CIM_LANConnectivitySegment represents a layer 2 segment or subnet within a network.
355 CIM_LANConnectivitySegment is associated with CIM_Network through CIM_HostedCollection.
- 356 5) CIM_IPConnectivitySubnet represents a layer 2 segment or subnet within a network.
357 CIM_IPConnectivitySubnet is associated with CIM_Network through CIM_HostedCollection.
- 358 6) CIM_NetworkVLAN represents a VLAN. CIM_NetworkVLAN is associated with CIM_Network
359 through CIM_HostedCollection.
- 360 7) CIM_ProtocolEndpoint represents a protocol endpoint. CIM_LANEndpoint represents layer 2
361 protocol endpoint. CIM_LANEndpoint is derived from CIM_ProtocolEndpoint. The relationship of
362 CIM_LANEndpoint with a specific CIM_LANConnectivitySegment is modeled by
363 CIM_MemberOfCollection. CIM_IPProtocolEndpoint represents IP layer endpoint.
364 CIM_IPProtocolEndpoint is also derived from CIM_ProtocolEndpoint. The relationship of
365 CIM_IPProtocolEndpoint with a specific CIM_IPConnectivitySubnet is modeled by
366 CIM_MemberOfCollection. CIM_VLANEndpoint represents layer 2 VLAN endpoint.
367 CIM_VLANEndpoint is derived from CIM_ProtocolEndpoint. The relationship of
368 CIM_VLANEndpoint with a specific CIM_NetworkVLAN is modeled by
369 CIM_MemberOfCollection. CIM_DeviceSAPImplementation models the relationship between
370 CIM_NetworkPort and CIM_ProtocolEndpoint. Connectivity between LAN endpoints is modeled

371 by CIM_ActiveConnection. Similarly, connectivity between IP protocol endpoints is modeled by
372 CIM_ActiveConnection.

373 CIM_NetworkPolicyService represents the service that is managing network policies.
374 CIM_HostingSystem represents the system hosting the network policy service. This relationship between
375 CIM_HostingSystem and CIM_NetworkPolicyService is represented by CIM_HostedService.
376 CIM_ServiceAffectsElement is used to represent the relationship between the CIM_NetworkPolicyService
377 and the resources affected by CIM_NetworkPolicyService.

378 Support for the Network Management Profile is advertised by CIM_RegisteredProfile.

379 **7 Implementation requirements**

380 This clause details the requirements related to the instantiations of instances and properties of instances
381 for implementations of this profile.

382 **7.1 Representing the Network Management Service**

383 An instance of CIM_NetworkManagementService represents a network management service.

384 At least one instance of CIM_NetworkManagementService shall exist.

385 Each instance of the CIM_NetworkManagementService shall be associated to the scoping instance of
386 CIM_System (HostingSystem) with CIM_HostedService association.

387 **7.2 Representing the Network Management Service Capabilities**

388 An instance of CIM_NetworkManagementServiceCapabilities represents network management service
389 capabilities.

390 One or more instances of CIM_NetworkManagementServiceCapabilities may exist.

391 Each instance of the CIM_NetworkManagementServiceCapabilities shall be associated to exactly one
392 instance of CIM_NetworkManagementService with CIM_ElementCapabilities association.

393 **7.3 Representing the Network**

394 **7.3.1 CIM_Network**

395 An instance of CIM_Network represents a network.

396 Zero or more instances of CIM_Network shall exist.

397 Each instance of the CIM_Network shall be associated to at least one instance of
398 CIM_NetworkManagementService with one instance of CIM_ServiceAffectsElement association.

399 **7.3.1.1 CIM_VLANNetwork**

400 VLAN networks represent a specialization of networks modeled in general.

401 An instance of CIM_VLANNetwork shall represent a VLAN network.

402 **7.3.2 Networks contained within a network**

403 If a network represented by an instance of CIM_Network is contained within a network represented by
404 another instance of CIM_Network, then the instance of CIM_Network shall be associated to the other
405 instance of CIM_Network with an instance of CIM_ContainedNetwork.

406 **7.3.3 Network dependency**

407 Networks can be dependent on each other. For example, an overlay L2 network that is dependent on
408 several underlying L3 networks.

409 CIM_Dependency shall be used to show dependency between networks.

410 The dependency of one network represented by an instance of CIM_Network on another network
411 represented by another instance of CIM_Network shall be represented by an instance of
412 CIM_Dependency that associates these two instances of CIM_Network.

413 **7.4 Representation of network ports**

414 **7.4.1 CIM_NetworkPort**

415 An instance of CIM_NetworkPort shall represent a network port.

416 Zero or more instances of CIM_NetworkPort may exist.

417 An instance of CIM_NetworkPort shall be associated to at least one instance of CIM_Network with an
418 instance of CIM_SystemComponent.

419 **7.4.2 CIM_LogicalPortGroup**

420 An instance of CIM_LogicalPortGroup shall represent a network port group.

421 Zero or more instances of CIM_LogicalPortGroup may exist.

422 An instance of CIM_LogicalPortGroup shall be associated with one instance of CIM_Network through an
423 instance of CIM_HostedCollection.

424 **7.5 Representation of collections of protocol endpoints**

425 **7.5.1 CIM_LANConnectivitySegment**

426 An instance of CIM_LANConnectivitySegment shall represent a collection of network layer 2 protocol
427 endpoints (see 7.6.1) that are connected within a network (see 7.3.1).

428 Zero or more instances of CIM_LANConnectivitySegment may exist.

429 Zero or more instances of CIM_LANEndpoint may be associated with an instance of
430 CIM_LANConnectivitySegment.

431 An instance of CIM_LANConnectivitySegment shall be associated to one instance of CIM_Network with
432 an instance of CIM_HostedCollection.

433 **7.5.2 CIM_IPConnectivitySubnet**

434 An instance of CIM_IPConnectivitySubnet shall represent a collection of network layer 3 protocol
435 endpoints (see 7.6.2) that are connected within a network (see 7.3.1).

436 Zero or more instances of CIM_IPConnectivitySubnet may exist.

437 Zero or more instances of CIM_IPProtocolEndpoint may be associated with an instance of
438 CIM_IPConnectivitySubnet.

439 An instance of CIM_IPConnectivitySubnet shall be associated to one instance of CIM_Network with an
440 instance of CIM_HostedCollection.

441 7.5.3 CIM_NetworkVLAN

442 An instance of CIM_NetworkVLAN shall represent a collection of VLAN endpoints (see 7.6.3) for a
443 specific VLAN within a network (see 7.3.1).

444 Zero or more instances of CIM_NetworkVLAN may exist.

445 Zero or more instances of CIM_VLANEndpoint may be associated with an instance of
446 CIM_NetworkVLAN.

447 For each instance of CIM_NetworkVLAN, all instances of CIM_VLANEndpoint associated with the
448 instance CIM_NetworkVLAN shall have the same value for the CIM_VLANEndpoint.VLANId and this
449 value shall be same as the value of CIM_NetworkVLAN.VLANId.

450 An instance of CIM_NetworkVLAN shall be associated to one instance of CIM_VLANNetwork with an
451 instance of CIM_HostedCollection.

452 7.6 Representation of protocol endpoints

453 7.6.1 CIM_LANEndpoint

454 An instance of CIM_LANEndpoint shall represent a network layer 2 protocol endpoint within a network
455 (see 7.3.1).

456 Zero or more instances of CIM_LANEndpoint may exist.

457 An instance of CIM_LANEndpoint shall either be 1) associated to one instance of CIM_NetworkPort with
458 one instance of CIM_DeviceSAPImplementation, or 2) associated to one instance of
459 CIM_LANConnectivitySegment with one instance of CIM_MemberOfCollection, or 3) both.

460 7.6.2 CIM_IPProtocolEndpoint

461 An instance of CIM_IPProtocolEndpoint shall represent a network layer 3 protocol endpoint within a
462 network.

463 Zero or more instances of CIM_IPProtocolEndpoint may exist.

464 An instance of CIM_IPProtocolEndpoint shall either be 1) associated to one instance of CIM_NetworkPort
465 with one instance of CIM_DeviceSAPImplementation, or 2) associated to one instance of
466 CIM_IPConnectivitySubnet with one instance of CIM_MemberOfCollection, or 3) both.

467 7.6.3 CIM_VLANEndpoint

468 An instance of CIM_VLANEndpoint shall represent a VLAN endpoint within a network.

469 Zero or more instances of CIM_VLANEndpoint may exist.

470 An instance of CIM_VLANEndpoint shall either be 1) associated to one instance of CIM_NetworkPort with
471 one instance of CIM_DeviceSAPImplementation, or 2) associated to one instance of CIM_NetworkVLAN
472 with one instance of CIM_MemberOfCollection, or 3) both.

473 An instance of CIM_VLANEndpoint may be associated to one instance of CIM_LANEndpoint with an
474 instance of CIM_BindsTo.

475 NOTE The relationships between these protocol endpoints are modeled by Ethernet Port Profile and IP
476 Configuration Profile.

477 7.7 CIM_NetworkSettingData

478 An instance of CIM_NetworkSettingData represents a configuration of a network or a template network
479 configuration.

480 An instance of CIM_NetworkSettingData shall be associated to an instance of CIM_Network or an
481 instance of CIM_NetworkManagementServiceCapabilities or an instance of CIM_NetworkCapabilities.

482 An instance of CIM_NetworkSettingData representing a configuration of an existing network shall be
483 associated to an instance of CIM_Network with an instance of CIM_ElementSettingData.

484 An instance of CIM_NetworkSettingData representing a template network configuration shall be
485 associated to an instance of CIM_NetworkManagementServiceCapabilities with an instance of
486 CIM_SettingsDefineCapabilities.

487 An instance of CIM_NetworkSettingData representing a template configuration of an existing network
488 shall be associated to an instance of CIM_NetworkCapabilities with an instance of
489 CIM_SettingsDefineCapabilities.

490 7.8 CIM_EthernetPortAllocationSettingData

491 An instance of CIM_EthernetPortAllocationSettingData represents a network port configuration. An
492 instance of CIM_EthernetPortAllocationSettingData can be used to represent a network port profile
493 defined by using DSP8049.

494 An instance of CIM_EthernetPortAllocationSettingData shall be associated to an instance of
495 CIM_NetworkPort or an instance of CIM_NetworkCapabilities.

496 An instance of CIM_EthernetPortAllocationSettingData representing a configuration of an existing
497 network port shall be associated to an instance of CIM_NetworkPort with an instance of
498 CIM_ElementSettingData.

499 An instance of CIM_EthernetPortAllocationSettingData representing a template network port configuration
500 shall be associated to an instance of CIM_NetworkCapabilities with an instance of
501 CIM_SettingsDefineCapabilities.

502 8 Methods

503 This clause details the requirements for supporting intrinsic operations and extrinsic methods for the CIM
504 elements defined by this profile.

505 8.1 Profile conventions for operations

506 For each profile class (including associations), the implementation requirements for operations, including
507 those in the following default list, are specified in class-specific subclauses of this clause.

508 The default list of operations is as follows:

- 509 • GetInstance
- 510 • EnumerateInstances
- 511 • EnumerateInstanceNames
- 512 • Associators
- 513 • AssociatorNames
- 514 • References
- 515 • ReferenceNames

516 8.2 CIM_NetworkManagementService

517 All operations in the default list in 8.1 shall be implemented as defined in [DSP0200](#).

518 8.3 CIM_NetworkManagementServiceCapabilities

519 All operations in the default list in 8.1 shall be implemented as defined in [DSP0200](#).

520 8.4 CIM_NetworkPolicyService

521 All operations in the default list in 8.1 shall be implemented as defined in [DSP0200](#).

522 8.5 CIM_RedundancySet

523 All operations in the default list in 8.1 shall be implemented as defined in [DSP0200](#).

524 8.6 CIM_Network

525 All operations in the default list in 8.1 shall be implemented as defined in [DSP0200](#).

526 8.7 CIM_VLANNetwork

527 All operations in the default list in 8.1 shall be implemented as defined in [DSP0200](#).

528 8.8 CIM_NetworkCapabilities

529 All operations in the default list in 8.1 shall be implemented as defined in [DSP0200](#).

530 8.9 CIM_NetworkSettingData

531 All operations in the default list in 8.1 shall be implemented as defined in [DSP0200](#).

532 8.10 CIM_EthernetPortAllocationSettingData

533 All operations in the default list in 8.1 shall be implemented as defined in [DSP0200](#).

534 8.11 CIM_NetworkPort

535 All operations in the default list in 8.1 shall be implemented as defined in [DSP0200](#).

536 8.12 CIM_EthernetPort

537 All operations in the default list in 8.1 shall be implemented as defined in [DSP0200](#).

538 8.13 CIM_LogicalPortGroup

539 All operations in the default list in 8.1 shall be implemented as defined in [DSP0200](#).

540 8.14 CIM_System

541 All operations in the default list in 8.1 shall be implemented as defined in [DSP0200](#).

542 8.15 CIM_ConnectivityCollection

543 All operations in the default list in 8.1 shall be implemented as defined in [DSP0200](#).

544 8.16 CIM_LANConnectivitySegment

545 All operations in the default list in 8.1 shall be implemented as defined in [DSP0200](#).

546 8.17 CIM_LANEndpoint

547 All operations in the default list in 8.1 shall be implemented as defined in [DSP0200](#).

548 8.18 CIM_IPConnectivitySubnet

549 All operations in the default list in 8.1 shall be implemented as defined in [DSP0200](#).

550 8.19 CIM_IPProtocolEndpoint

551 All operations in the default list in 8.1 shall be implemented as defined in [DSP0200](#).

552 8.20 CIM_NetworkVLAN

553 All operations in the default list in 8.1 shall be implemented as defined in [DSP0200](#).

554 8.21 CIM_VLANEndpoint

555 All operations in the default list in 8.1 shall be implemented as defined in [DSP0200](#).

556 8.22 CIM_RegisteredProfile

557 All operations in the default list in 8.1 shall be implemented as defined in [DSP0200](#).

558 8.23 CIM_ElementConformsToProfile

559 All operations in the default list in 8.1 shall be implemented as defined in [DSP0200](#).

560 8.24 CIM_HostedService

561 All operations in the default list in 8.1 shall be implemented as defined in [DSP0200](#).

562 8.25 CIM_ElementCapabilities

563 All operations in the default list in 8.1 shall be implemented as defined in [DSP0200](#).

564 8.26 CIM_ServiceAffectsElement

565 All operations in the default list in 8.1 shall be implemented as defined in [DSP0200](#).

566 8.27 CIM_ContainedNetwork

567 All operations in the default list in 8.1 shall be implemented as defined in [DSP0200](#).

568 8.28 CIM_MemberOfCollection

569 All operations in the default list in 8.1 shall be implemented as defined in [DSP0200](#).

570 8.29 CIM_HostedCollection

571 All operations in the default list in 8.1 shall be implemented as defined in [DSP0200](#).

572 8.30 CIM_Dependency

573 All operations in the default list in 8.1 shall be implemented as defined in [DSP0200](#).

574 8.31 CIM_PeerNetwork

575 All operations in the default list in 8.1 shall be implemented as defined in [DSP0200](#).

576 8.32 CIM_ElementSettingData

577 All operations in the default list in 8.1 shall be implemented as defined in [DSP0200](#).

578 8.33 CIM_SystemComponent

579 All operations in the default list in 8.1 shall be implemented as defined in [DSP0200](#).

580 8.34 CIM_SettingsDefineCapabilities

581 All operations in the default list in 8.1 shall be implemented as defined in [DSP0200](#).

582 8.35 CIM_SystemDevice

583 All operations in the default list in 8.1 shall be implemented as defined in [DSP0200](#).

584 8.36 CIM_DeviceConnection

585 All operations in the default list in 8.1 shall be implemented as defined in [DSP0200](#).

586 8.37 CIM_ActiveConnection

587 All operations in the default list in 8.1 shall be implemented as defined in [DSP0200](#).

588 8.38 CIM_DeviceSAPImplementation

589 All operations in the default list in 8.1 shall be implemented as defined in [DSP0200](#).

590 **9 Use cases**

591 This clause contains object diagrams and use cases for the *Network Management Profile*.

592 **9.1 Miscellaneous object diagrams**

593 The object diagram in Figure 2 shows one possible method for advertising profile conformance.



594

595

Figure 2 – Registered profile

596

597 **9.2 Representing VLAN networks within an L2 network**

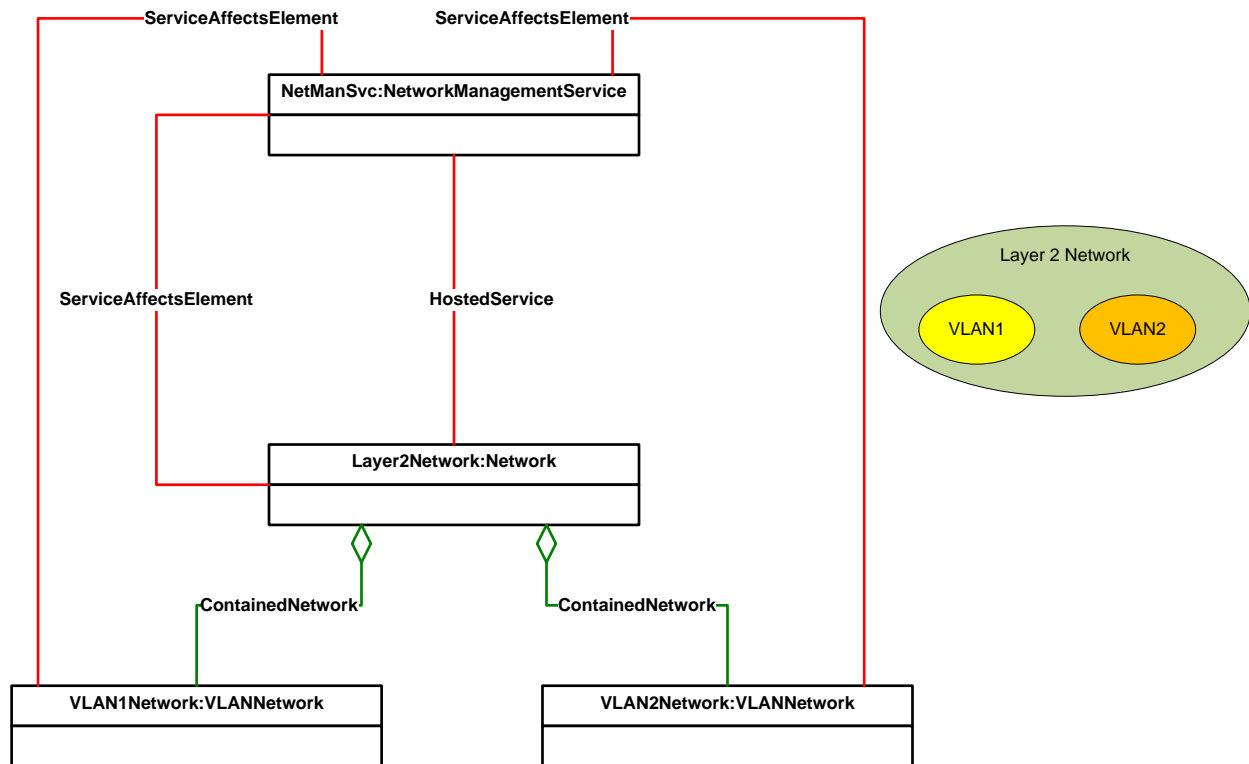

598

599 **Figure 3 – Two VLAN networks within a Layer 2 network**

600 In this example, two networks with their individual VLAN domains are instantiated inside a layer 2
 601 network. The instance of layer 2 network *Layer2Network* is the parent of the instances *VLAN1Network*
 602 and *VLAN2Network*. *NetManSvc* represents the service that is hosted on the layer 2 network. *NetManSvc*
 603 manages all three networks as represented by *ServiceAffectsElement*.

604 **9.3 Representing underlay IP networks within an L2 overlay network**

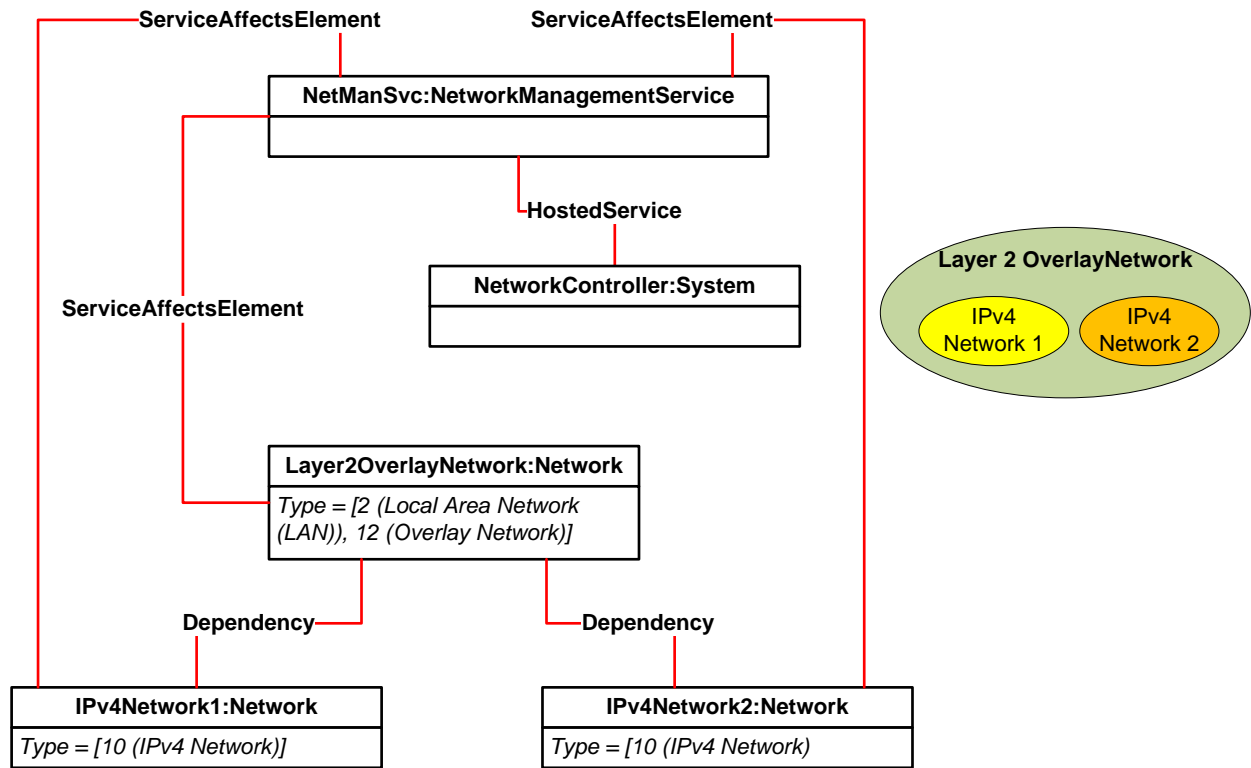

605

606 **Figure 4 – Two IPv4 underlay networks creating a layer 2 overlay network**

607 In this example, two IPv4 networks with their individual domains are instantiated to create a layer 2
 608 overlay network. The instance of layer 2 overlay network *Layer2OverlayNetwork* is dependent on the
 609 instances *IPv4Network1* and *IPv4Network2*. *NetManSvc* represents the service that is hosted on the
 610 *NetworkController* (e.g., an SDN controller). *NetManSvc* manages all three networks (one overlay
 611 network and two underlay networks) as represented by *ServiceAffectsElement*.

612 **9.4 Representing two peer IP networks**

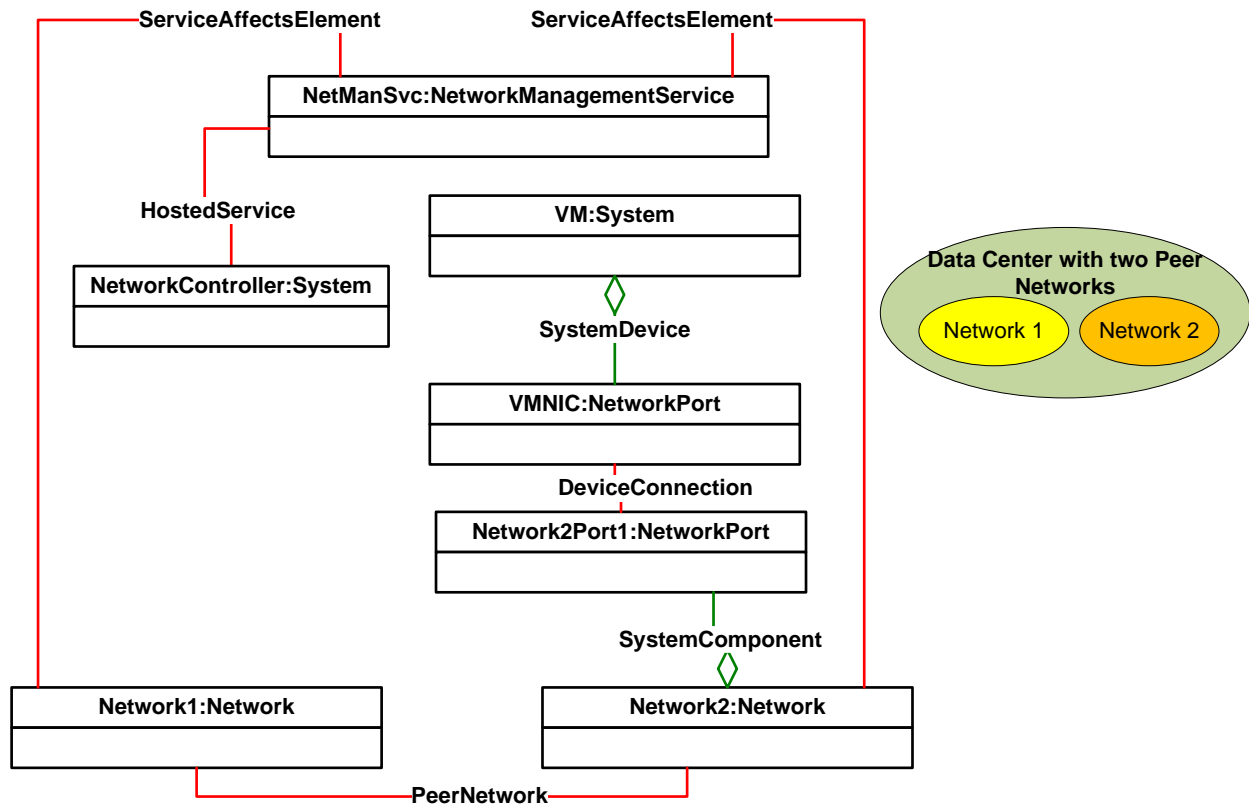

613

614 **Figure 5 – Two peer managed networks**

615 A network administrator trying to deploy a VM on a network *Network1* finds out that *Network1* does not
 616 have additional resources. In this case, the network administrator finds a peer network *Network2* with
 617 available network resources and deploys the VM on the peer network *Network2*.

618 In this example, two peer networks are represented by two instances *Network1* and *Network2*. The
 619 instance of *PeerNetwork* shows relationship between *Network1* and *Network2*. *NetManSvc* represents
 620 the service that is hosted on a system *NetworkController*. *NetManSvc* manages both peer networks as
 621 represented by *ServiceAffectsElement*. The instance *VM* is connected to *Network2*. That connection is
 622 represented by *DeviceConnection* association between *VMNIC* and *Network2Port1*.

623 Future Example: A data center administrator is supporting multiple tenants each with its own set of
 624 resources including networks. Each tenant within its domain can administer movement of VMs and
 625 network resources. When a tenant network runs out of network resources, the data center administrator
 626 finds peer networks with available network resources and reallocates network resources to the given
 627 tenant network.

628

629 **9.5 Representing two tenant networks within a provider network**

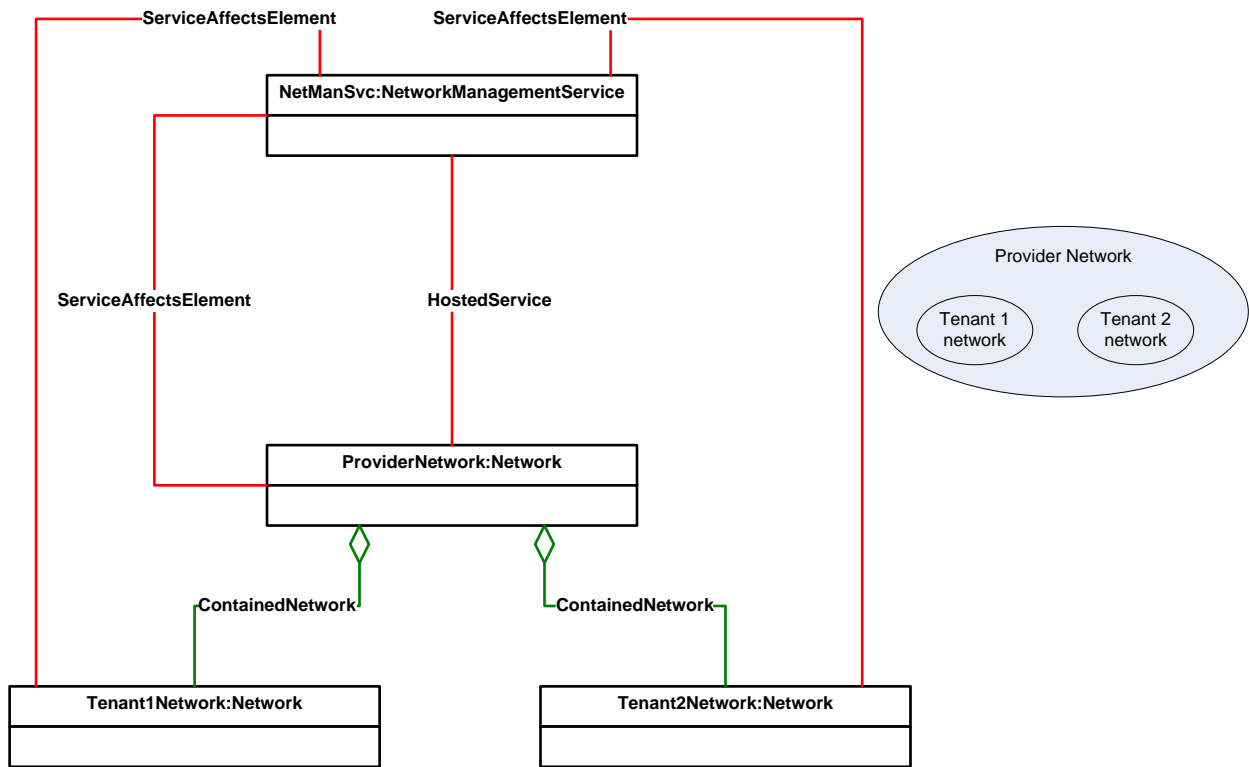

630

631

Figure 6 – Two tenant networks within a provider network

632 **9.6 Representing ethernet ports of tenant networks**

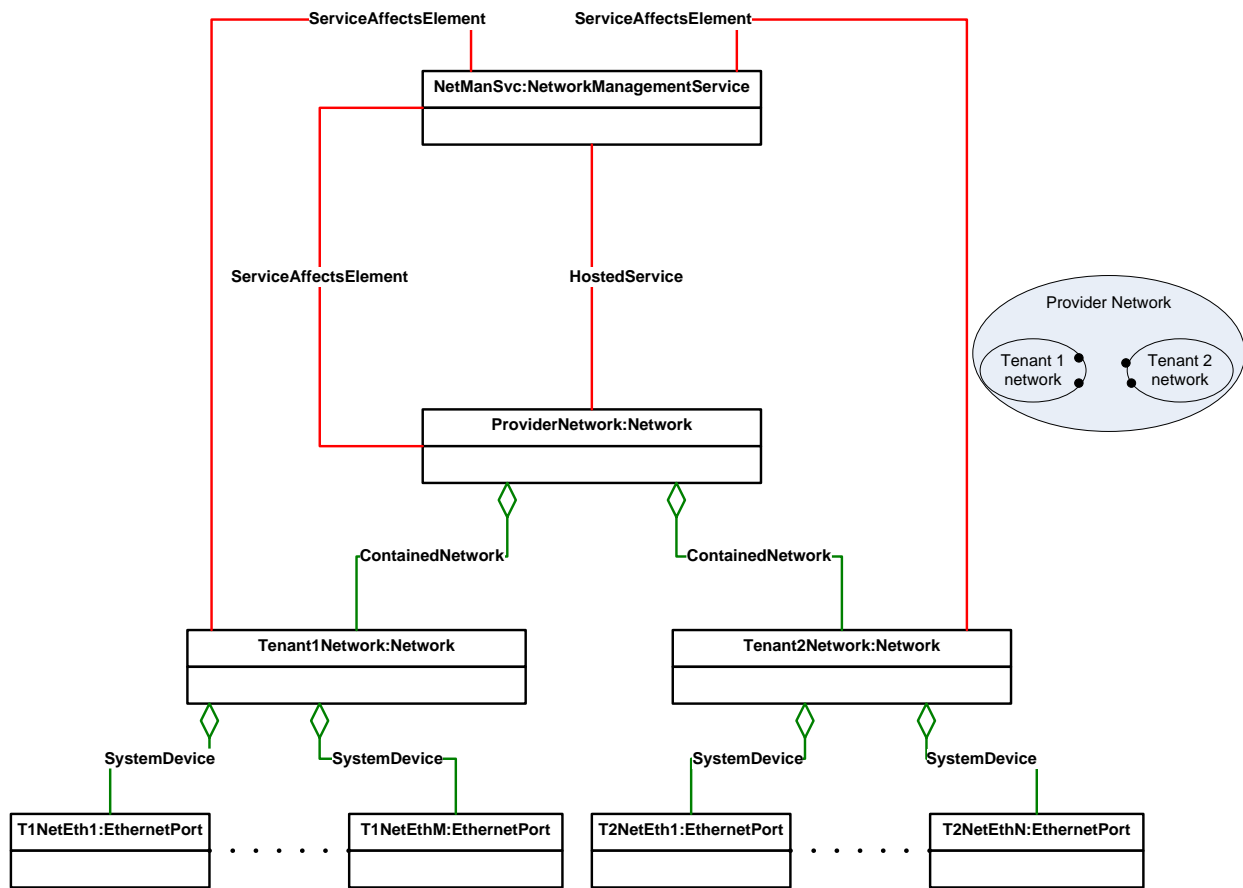

633

634 **Figure 7 – Representing ethernet ports of two tenant networks within a provider network**

635 **9.7 Representing systems connected to ethernet ports of tenant networks**

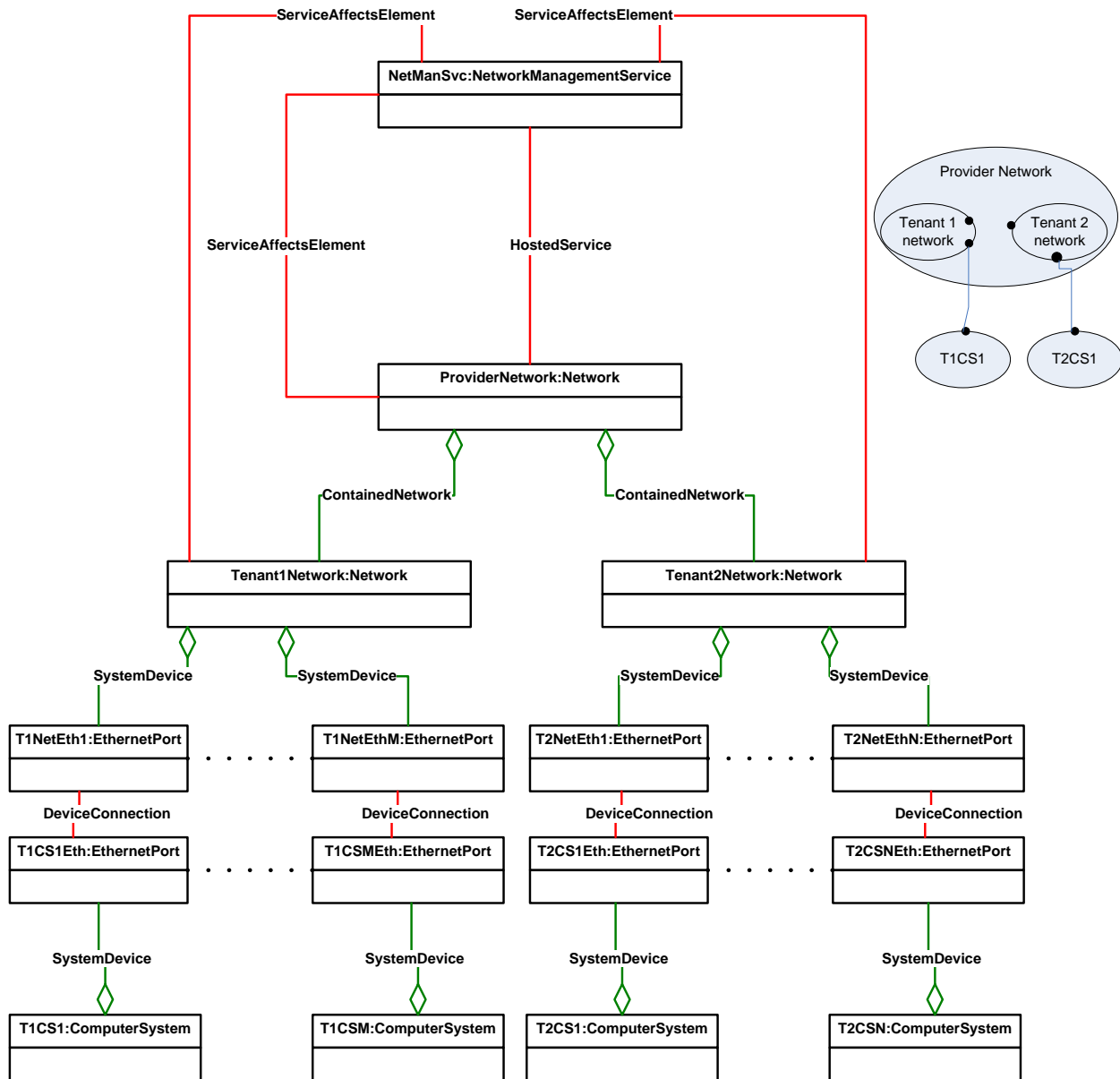

636

637 **Figure 8 – Representing systems connected to ethernet ports of two tenant networks within a**
 638 **provider network**

639 **9.8 Representing a tunneled network connecting two ethernet networks**

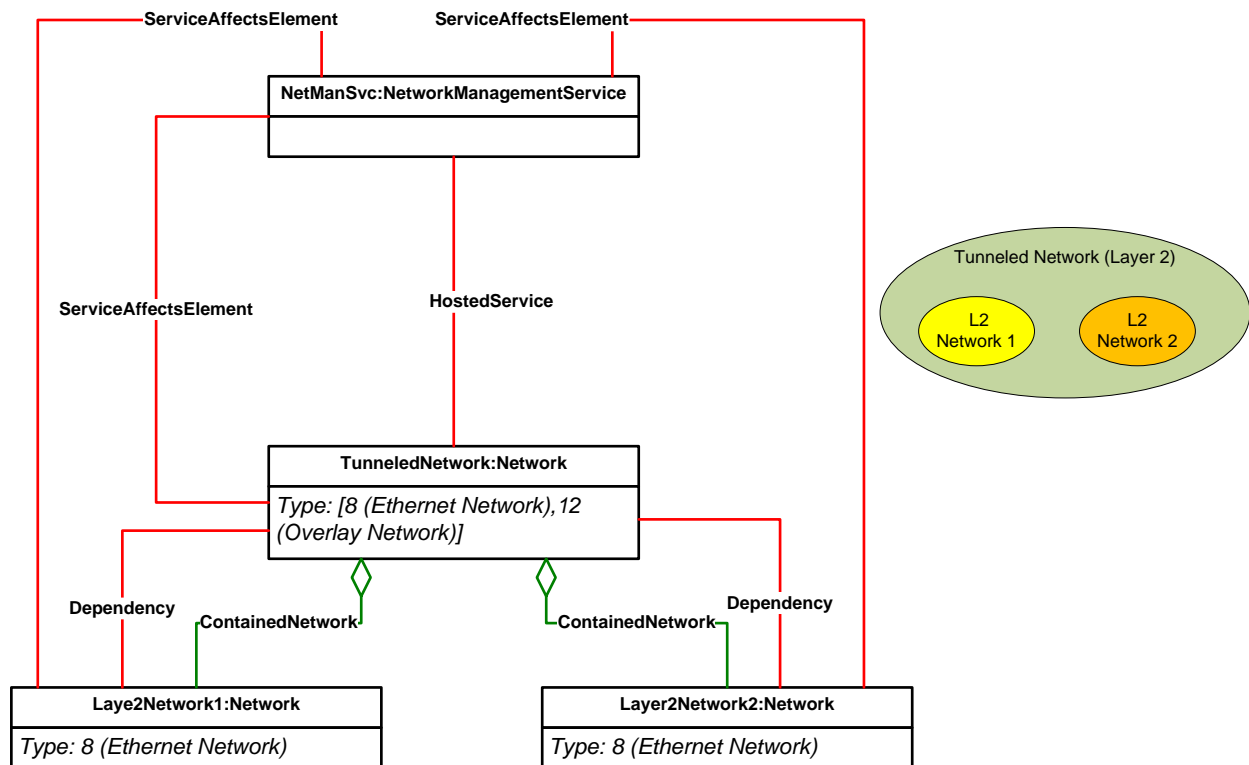

640

641 **Figure 9 – Representing a tunneled network bridging two ethernet networks**

642 **9.9 Enumerate networks**

643 A client can list all the networks by enumerating all instances of `CIM_Network`.

644 **9.10 Enumerate contained networks within a specific network**

645 A client can list all the networks contained within a network as follows:

- 646 1) Find all instances of `CIM_Network` that are associated with the given instance of `CIM_Network`
 647 through an instance of `CIM_ContainedNetwork`.

648 **9.11 Create one or more networks**

649 A client can create one or more networks contained within a network as follows:

- 650 1) Extrinsic method on `CIM_NetworkManagementService`.

651 **9.12 Create one or more networks within a network**

652 A client can create one or more networks contained within a network as follows:

- 653 1) Extrinsic method on `CIM_Network`.

654 9.13 Delete a network

655 A client can delete an instance of CIM_Network.

656 9.14 Discover logical ports of a network

657 A client can discover all the ports within a network as follows:

- 658 1) Enumerate all instances of CIM_NetworkPort that are associated with the given instance of
659 CIM_Network through an instance of CIM_SystemComponent.

660 9.15 Discover logical port groups of a network

661 A client can discover all the logical port groups within a network as follows:

- 662 1) Enumerate all instances of CIM_LogicalPortGroup that are associated with the given instance of
663 CIM_Network through an instance of CIM_HostedCollection.

664 9.16 Discover IP subnets of a network

665 A client can discover all the logical port groups within a network as follows:

- 666 1) Enumerate all instances of CIM_IPConnectivitySubnet that are associated with the given
667 instance of CIM_Network through an instance of CIM_HostedCollection.

668 9.17 Discover VLANs of a network

669 A client can discover all the VLANs within a network as follows:

- 670 1) Enumerate all instances of CIM_NetworkVLAN that are associated with the given instance of
671 CIM_Network through an instance of CIM_HostedCollection.
- 672 2) For each instance of CIM_NetworkVLAN in 1, Enumerate all instances of CIM_VLANEndpoint
673 that are associated with the given instance of CIM_NetworkVLAN through an instance of
674 CIM_MemberOfCollection.

675 9.18 Discover L2 segments of a network

676 A client can discover all the logical port groups within a network as follows:

- 677 1) Enumerate all instances of CIM_LANConnectivitySegment that are associated with the given
678 instance of CIM_Network through an instance of CIM_HostedCollection.

679 9.19 Discover systems within a network

680 A client can discover all the logical port groups within a network as follows:

- 681 1) Enumerate all instances of CIM_System that are associated with the given instance of
682 CIM_Network through an instance of CIM_SystemComponent.

**683 9.20 Enumerate networks that a system is directly connected to (intrinsic
684 method)**

685 A client can discover all the logical port groups within a network as follows:

- 686 1) Enumerate all instances of CIM_Network that are associated with the given instance of
687 CIM_System through an instance of CIM_SystemComponent.

688

689

690 **10 CIM Elements**

691 Table 2 shows the instances of CIM Elements for this profile. Instances of the CIM Elements shall be
 692 implemented as described in Table 2. Clauses 7 (“Implementation”) and 8 (“Methods”) may impose
 693 additional requirements on these elements.

694 **Table 2 – CIM Elements: Network Services Management Profile**

Element Name	Requirement	Description
Classes		
CIM_NetworkManagementService	Optional	See clause 8.2
CIM_NetworkManagementServiceCapabilities	Optional	See clause 8.3
CIM_NetworkPolicyService	Optional	See clause 8.4
CIM_Network	Mandatory	See clause 8.6
CIM_NetworkCapabilities	Optional	See clause 8.8
CIM_NetworkSettingData	Optional	See clause 8.9
CIM_EthernetPortAllocationSettingData	Optional	See clause 8.10
CIM_RedundancySet	Optional	See clause 8.5
CIM_LogicalPortGroup	Optional	See clause 8.13
CIM_NetworkPort	Optional	See clause 8.11
CIM_EthernetPort	Optional	See clause 8.12
CIM_System	Optional	See clause 8.14
CIM_ConnectivityCollection	Optional	See clause 8.15
CIM_LANConnectivitySegment	Optional	See clause 8.16
CIM_LANEndpoint	Optional	See clause 8.17
CIM_IPConnectivitySubnet	Optional	See clause 8.18
CIM_IPProtocolEndpoint	Optional	See clause 8.19
CIM_NetworkVLAN	Optional	See clause 8.20
CIM_VLANEndpoint	Optional	See clause 8.21
CIM_RegisteredProfile	Mandatory	See clause 8.22
Associations		
CIM_ElementConformsToProfile	Mandatory	
CIM_HostedService	Optional	
CIM_ElementCapabilities	Optional	
CIM_ServiceAffectsElement	Optional	
CIM_ContainedNetwork	Optional	
CIM_MemberOfCollection	Optional	
CIM_HostedCollection	Optional	
CIM_Dependency	Optional	

Element Name	Requirement	Description
CIM_PeerNetwork	Optional	
CIM_ElementSettingData	Optional	
CIM_SystemComponent	Optional	
CIM_SettingsDefineCapabilities	Optional	
CIM_SystemDevice	Optional	
CIM_DeviceConnection	Optional	
CIM_ActiveConnection	Optional	
CIM_DeviceSAPImplementation	Optional	
Indications		
None defined in this profile		

695

696
697
698
699

ANNEX A (informative)

Change log

Version	Date	Description
1.0.0	2020-05-18	

700
701