

Other Test Method 49 (OTM-49) Determination of Polychlorinated Dibenzo-*p*-Dioxins, Polychlorinated Dibenzofurans, Polychlorinated Biphenyls, and Polycyclic Aromatic Hydrocarbons from Stationary Sources by Gas Chromatography/Tandem Mass Spectrometry (GC-MS/MS)

Background on OTM-49

The posting of a test method on the Other Test Methods portion of the EMC website is neither an endorsement by EPA regarding the validity of the test method nor a regulatory approval of the test method. The purpose of the Other Test Methods portion of the EMC website is to promote discussion of developing emission measurement methodologies and to provide regulatory agencies, the regulated community, and the public at large with potentially helpful tools. Other Test Methods are test methods which have not yet been subject to the Federal rulemaking process. Each of these methods, as well as the available technical documentation supporting them, have been reviewed by the EMC staff and have been found to be potentially useful to the emission measurement community. The types of technical information reviewed include field and laboratory validation studies; results of collaborative testing; articles from peer-reviewed journals; peer review comments; and quality assurance (QA) and quality control (QC) procedures in the method itself. The EPA strongly encourages the submission of additional supporting field and laboratory data as well as comments regarding these methods.

These methods may be considered for use in federally enforceable State and local programs [e.g., Title V permits, State Implementation Plans (SIP)] provided they are subject to an EPA Regional SIP approval process or permit veto opportunity and public notice with the opportunity for comment. The methods may also be candidates to be alternative methods to meet Federal requirements under 40 CFR Parts 60, 61, and 63. However, they must be approved as alternatives under Parts 60.8, 61.13, or 63.7(f) before a source may use them for this purpose. Consideration of a method's applicability for a particular purpose should be based on the stated applicability as well as the supporting technical information. The methods are available for application without EPA oversight for other non-EPA program uses including state permitting programs and scientific and engineering applications. As many of these methods are submitted by parties outside the Agency, the EPA staff may not necessarily be the technical experts on these methods. Therefore, technical support from EPA for these methods is limited, but the table at the end of this introduction contains contact information for the authors and developers so that you may contact them directly. Also, be aware that these methods are subject to change based on the review of additional validation studies or on public comment as a part of adoption as a Federal test method, the Title V permitting process, or inclusion in a SIP.

Validated measurement methods are limited and under development for reliably identifying and quantifying if PCDD/PCDF, PAH, or PCB are released into the air from stationary sources. The current trend to measure these targets at trace concentrations and the limited availability of data on the performance of tandem mass spectrometric methods to measure these targets catalyze release of a possible new instrumental detection of samples collected by conventional isokinetic methods (Method 23 or SW 846 Method 0023a) as an alternative to high resolution mass spectrometric analysis. This OTM provides a consistent method for use by the facilities, stationary source test teams, research laboratories, and other stakeholders to measure these target

compounds emitted from vents and stacks. This OTM includes performance-based measurement tools and performance criteria for this method.

The sampling and sample preparation imbedded in OTM 49 are consistent with Method 23. Posting this method, in and of itself, does not establish a requirement, although the use of this method may be specified by the EPA, state, or local authorities through independent actions. Terms such as “must” or “required,” as used in this document, refer to procedures that are to be followed to conform with the method. References to specific brands and catalog numbers are included only as examples and do not imply endorsement of the products. Such reference does not preclude the use of equivalent products from other vendors or suppliers.

OTM 49 is a draft method under evaluation that will be updated as necessary when more data from stakeholders becomes available. Due to the need for consistency, this method is being released as an “Other Test Method (OTM)” by EPA’s Emission Measurements Center to promote consistency with what we believe is the current best practices to sample and analyze the method targets from stationary sources. We solicit feedback, comments, and additional data coming from the application of this method as we work to adjust and evaluate this method.

Note: Please submit a copy, either electronic or paper, of any test report from application of this OTM to EPA’s Measurement Technology Group.

- **Electronic copies should be submitted via email with the subject line “OTM-049” to: EMC@epa.gov**
- **Paper copies should be mailed to:
Measurement Technology Group
Office of Air Quality Planning and Standards
U.S. Environmental Protection Agency (Mail Code E143-02)
Research Triangle Park, NC 27711**

Other Test Method 49 (OTM 49) Determination of Polychlorinated Dibenzo-*p*-Dioxins, Polychlorinated Dibenzofurans, Polychlorinated Biphenyls, and Polycyclic Aromatic Hydrocarbons from Stationary Sources by Gas Chromatography/Tandem Mass Spectrometry (GC-MS/MS)

1.0 Scope and Application

1.1 Applicability. This method applies to the measurement of polychlorinated dibenzo-*p*-dioxins and polychlorinated dibenzofurans (PCDD/PCDF), polychlorinated biphenyls (PCB), and/or polycyclic aromatic hydrocarbons (PAH) in emissions from stationary sources. Using this method, you can measure these analyte groups individually, or in any combination using a single sample acquisition unless otherwise specified in a rule, regulation, or permit. Tables OTM 49-1 through 49-3 of this method list the applicable target analytes. If all 209 PCB are analyzed, the 17 toxic PCB congeners should be resolved and reported while the other PCB can be reported as totals by homolog, for example, total trichlorobiphenyl (TrCB).

1.2 Scope. This method describes the sampling and analytical procedures used to measure selected PCDD, PCDF, PAH, and PCB in combination or individually in stationary sources when required in an applicable subpart, Federally enforceable permit. This method incorporates by reference some of the specifications (e.g., equipment and supplies) and procedures (e.g., sampling and analytical) from other methods in this part that are essential to conducting this method. This method employs isokinetic sampling procedures and gas chromatography coupled with tandem quadrupole mass spectrometry (GC-MS/MS) analysis procedures. To obtain reliable samples, source sampling teams should be trained and experienced with the following additional EPA test methods: Method 1, Method 2, Method 3, Method 4, and Method 5 of Appendices A-1,

A-2, and A-3 to 40 Code of Federal Regulations (CFR) Part 60. Laboratory analysis teams should have a working knowledge of isotope dilution and the use of gas chromatography coupled with tandem mass spectrometry.

1.3 Laboratory analysis should be performed by or under the supervision of analysts trained and with experience in liquid phase extractions, gas chromatography and tandem quadrupole mass spectrometry systems.

1.4 This method provides some flexibility for analysis of target compounds by including the addition of isotopically labeled standards in various parts of the sampling system to assess and evaluate method performance against criteria for successful sampling and analysis procedures. Users may modify the method to overcome interferences or to substitute superior materials and equipment, or to lower costs provided they use isotope dilution quantitation with labeled standards and GC-MS/MS as the basis for separation and quantitation of method target compounds and meet all performance criteria in Section 9 of this method.

2.0 Summary of Method

This method identifies and determines the amount of specific PCDD, PCDF, PCB, and PAH compounds in stationary source samples. This method also allows the determination of PCDD, PCDF, PCB homolog totals by the level of chlorination, if needed. Gaseous and particulate bound target pollutants are withdrawn from the gas stream isokinetically during field sampling and collected in the sample probe, on a glass fiber or quartz filter, on a trap containing adsorbent material and in aqueous impingers. This method is not intended to differentiate between target compounds in particulate or vapor fractions.

2.1 Laboratory media preparation includes spiking XAD-2 sorbent prior to sampling and prior to extraction with isotopic analogs of the target compounds.

2.2 *The target compounds* are extracted from the combined sample collection media. Portions of the extract are chromatographically fractionated to remove interferences, separated into individual compounds or simple mixtures by GC, and measured with MS/MS. This method uses isotope dilution quantitation with pre-extraction isotopically labeled standards to improve method accuracy and precision.

3.0 *Definitions*

3.1 *Alternate Recovery Standards*. A group of isotopically labeled compounds that is not otherwise designated in this method for quality control (QC) purposes. Alternative recovery standards can be used to assess the recovery of a compound class relative to any step in the sampling and analysis procedure that is not already assessed as a mandatory part of this method.

3.2 *Analysis Batch*. A set of samples that are analyzed on the same instrument during a 12-hour period, of no more than 20 field samples and includes all required QC samples. The required QC samples are not included in counting the maximum field sample total of 20.

3.3 *Calibration Standard*. A solution of the method target analytes, pre-extraction standards, and pre-analysis standard(s) prepared from the Primary Dilution Standards (PDS) and stock standards. The calibration standards are used to calibrate the instrument response with respect to analyte concentration.

3.4 *Collisional Induced Dissociation (CID)*. Collisional induced dissociation using a neutral gas.

3.5 *Continuing Calibration Check (CCC)*. A standard prepared at the mid-point concentration of the calibration used to verify the initial calibration. Prepare the CCC standard at the same time as the batch of field samples using the same labeled standards.

3.6 Congener. An individual compound with a common structure (dioxin, furan, or biphenyl), only differing by the number of chlorine or other substituent attached to the structure.

3.7 Estimated Maximum Possible Concentration (EMPC). An EMPC is a worst-case estimate of the target compound concentration. Report the results as EMPC when the transition ratio for a target analyte is outside the performance criteria. Calculate the EMPC using both quantitation ions.

3.8 Extraction Batch. A set of field samples and field blanks extracted together using the same lot of extraction devices, solvents, and isotopically labeled solutions.

3.9 Field Train Proof Blank (FTPB). A field train proof blank is a QC sample to evaluate equipment preparation and potential contamination during sample recovery and consists of a fully assembled train at the sampling site, without actual sampling. The field train proof blank train uses glassware from the same preparation batch as the field samples.

3.10 Homolog. A compound belonging to a series of compounds with the same general molecular formula, differing from each other by the number of repeating units of chlorine.

3.11 Isomer. An individual compound with a common structure (dioxin, furan, or biphenyl), only differing by the position of chlorine atoms attached to the structure.

3.12 Isotope Dilution. A means of determining a naturally occurring (native) compound by reference to the same compound in which one or more atoms has been isotopically enriched.

3.13 Isotopologue. An individual compound with an identical chemical formula and structure, differing only in isotopic composition.

3.14 Kuderna-Danish concentrator (KD). A device used to concentrate the analytes in a solvent.

3.15 Laboratory Fortified Media Blank (LFMB). Also commonly referred to as Laboratory Control Sample. The LFMB includes and represents all the sampling media (i.e., filter, XAD-2 adsorbent) and reagents (i.e., impinger contents, rinsing solvents) associated with the field sample collection and recovery to which known quantities of the target analytes and isotope dilution analogues are added. The results of the LFMB verify method performance in the absence of sample matrix.

3.16 Laboratory Method Blank (LMB). A quality control sample to assess background contamination or interference from media, reagents, equipment, etc. An LMB is prepared in the laboratory, composed of clean sampling media (filter and XAD-2 media), using the same labeled standards, reagents and materials (sodium sulfate, glass wool, etc.) and processed (extraction, fractionation, cleanup) and analyzed using the same procedures as a field sample.

3.17 Method Detection Limit (MDL). The minimum concentration of an analyte that can be identified, measured, and reported with 99% confidence that the analyte concentration is greater than zero.

Note: MDL is determined following 40 CFR Part 136 Appendix B. Procedures for determining MDL for this method are in Section 9.2.2.4.

3.18 Multiple Reaction Monitoring (MRM). Two or more reactions, or transitions that are monitored for each target compound. Typically, one reaction is used for quantitation and one reaction is used for qualification.

3.19 Polychlorinated Biphenyl (PCB) Congeners. Any or all two hundred nine (209) chlorinated biphenyl congeners. Applicable PCB target compounds are listed in Table OTM 49-3 of this method and the full list of 209 PCB congeners and isomers is provided in Appendix A of this method.

3.19.1 Monochlorobiphenyl (MoCB). Any or all three (3) monochlorinated biphenyl isomers.

3.19.2 Dichlorobiphenyl (DiCB). Any or all twelve (12) dichlorinated biphenyl isomers.

3.19.3 Trichlorobiphenyl (TrCB). Any or all twenty-four (24) trichlorinated biphenyl isomers.

3.19.4 Tetrachlorobiphenyl (TeCB). Any or all forty-two (42) tetrachlorinated biphenyl isomers.

3.19.5 Pentachlorobiphenyl (PeCB). Any or all forty-six (46) pentachlorinated biphenyl isomers.

3.19.6 Hexachlorobiphenyl (HxCB). Any or all forty-two (42) hexachlorinated biphenyl isomers.

3.19.7 Heptachlorobiphenyl (HpCB). Any or all twenty-four (24) heptachlorinated biphenyl isomers.

3.19.8 Octachlorobiphenyl (OcCB). Any or all twelve (12) octachlorinated biphenyl isomers.

3.19.9 Nonachlorobiphenyl (NoCB). Any or all three (3) nonachlorinated biphenyl isomers.

3.19.10 Decachlorobiphenyl (DeCB). Biphenyl fully chlorinated with ten (10) chlorine atom substituents replacing hydrogen in the parent compound.

3.20 *Polychlorinated dibenzo-p-dioxin (PCDD) congeners.* Any or all seventy-five (75) chlorinated dibenzo-*p*-dioxin congeners. There are seven (7) 2,3,7,8 substituted PCDD congeners and four (4) PCDD homolog groups listed in Table OTM 49-1 of this method. Mono- through

tri-PCDD are not measured by this method and non-2,3,7,8 substituted congeners can be included in homolog totals, if needed.

3.20.1 Tetrachlorodibenzo-*p*-dioxin (TeCDD). Any or all twenty-two (22) tetrachlorinated dibenzo-*p*-dioxin isomers.

3.20.2 Pentachlorodibenzo-*p*-dioxin (PeCDD). Any or all fourteen (14) pentachlorinated dibenzo-*p*-dioxin isomers.

3.20.3 Hexachlorodibenzo-*p*-dioxin (HxCDD). Any or all ten (10) hexachlorinated dibenzo-*p*-dioxin isomers.

3.20.4 Heptachlorodibenzo-*p*-dioxin (HpCDD). Any or all two (2) heptachlorinated dibenzo-*p*-dioxin isomers.

3.20.5 Octachlorodibenzo-*p*-dioxin (OCDD). Dibenzodioxin fully chlorinated with eight (8) chlorine atom substituents replacing hydrogen in the parent compound.

3.21 *Polychlorinated dibenzofuran (PCDF) congeners.* Any or all possible chlorinated dibenzofuran congeners. There are ten (10) 2,3,7,8 substituted congeners and four (4) PCDF homolog groups listed in Table OTM 49-1 of this method. Mono- through tri-PCDF are not measured by this method and non-2,3,7,8 substituted congeners are not included in this method in the total homolog categories.

3.21.1 Tetrachlorodibenzofuran (TeCDF). Any or all thirty-eight (38) tetrachlorinated dibenzofuran isomers.

3.21.2 Pentachlorodibenzofuran (PeCDF). Any or all twenty-eight (28) pentachlorinated dibenzofuran isomers.

3.21.3 Hexachlorodibenzofuran (HxCDF). Any or all sixteen (16) hexachlorinated dibenzofuran isomers.

3.21.4 Heptachlordibenzofuran (HpCDF). Any or all four (4) heptachlorinated dibenzofuran isomers.

3.21.5 Octachlorodibenzofuran (OCDF). Dibenzofuran fully chlorinated with eight (8) chlorine atom substituents replacing hydrogen in the parent compound.

3.22 *Polychlorinated diphenyl ethers (PCDPE)*. Any or all chlorinated substituted diphenyl ethers.

3.23 *Polycyclic Aromatic Hydrocarbons (PAH)*. Any or all aromatic compounds with two (2) or more fused six-member rings. Table OTM 49-2 of this method lists the target PAH compounds for this method. Additional PAH compounds may be analyzed by adding the appropriate ¹³C isotopically labeled compound to the pre-extraction standard mixture and by following the other requirements for target PAH compounds in this method.

3.24 *Pre-analysis Standard*. A group of isotopically labeled compounds added at a known amount immediately prior to analysis and used to monitor instrument response, injection errors, instrument drift and to determine the recovery of the pre-extraction standard compounds. Pre-analysis standard is added to every sample (including blank, QC samples, and calibration solutions) at a known amount.

3.25 *Precursor Ion*. The gas-phase species corresponding to the method analyte that is produced in the ionization interface of the GC-MS/MS.

3.26 *Pre-extraction Filter Recovery Standard*. A group of isotopically labeled compounds added at a known amount to the filter just prior to extraction. The pre-extraction filter recovery standard is used to indicate the extraction efficiency of the filter media but is not used for quantitating or recovery correction.

3.27 Pre-extraction Standard. A group of isotopically labeled compounds added in a known amount to the XAD-2 adsorbent resin of each sample immediately before extraction and used for quantitation of target and other labeled compounds to correct for extraction, cleanup, and concentration recovery. These isotopically labeled compounds constitute a matrix spike of the resin. Pre-extraction standard is added to every sample at the same level (including blank, QC samples, and calibration solutions).

3.28 Pre-sampling Adsorbent Standard. A group of isotopically labeled compounds added in a known amount to the XAD-2 adsorbent prior to sampling and used to monitor the sampling aspects of the method.

3.29 Product Ion. One or more fragment ions that are produced in MS/MS by collision activated dissociation of the precursor ion.

3.30 Primary Dilution Standard (PDS). A solution that contains method analytes (or QC analytes) prepared from stock standards. PDS solutions are used to fortify QC samples and diluted to prepare calibration standards.

3.31 Quality Control Standard (QCS). A mid-level standard prepared from a source of standards different from the source of calibration standards. The purpose of the QCS is to verify the integrity of the primary calibration standards. A QCS is analyzed during the initial demonstration of capability (IDC) and following each initial calibration (at a minimum quarterly) thereafter.

3.32 Quantitative Reporting Limit (QRL). The minimum quantitative level that can be reported. The QRL is based on the lowest concentration of a target compound used during calibration.

3.33 Relative Response Factor (RRF). The response of the mass spectrometer to a known amount of an analyte relative to a known amount of an isotopically labeled standard.

3.34 Stack Detection Limit (SDL). The minimum qualitatively recognizable gaseous stack concentration above background for a target compound in units of mass/sample volume.

3.35 Toxic Equivalency Quotient (2,3,7,8-TeCDD-TEQ). A procedure that expresses the toxicity of PCDD, PCDF, and PCB in terms of the most toxic dioxin, as specified in applicable regulations, permits, or other requirements.

4.0 Interferences

Despite interferences, confidence of the data is based on the enhanced selectivity of fractionation, gas chromatograph (GC) separation and detector selection.

4.1 Target compound contaminants or related organics in solvents, reagents, glassware, isotopically labeled spiking standards, and other sample processing hardware are potential method interferences. Labeled standards can include trace quantities of native target compounds and should be screened before use. The adsorbent resin, XAD-2, is known to include background PAH, such as naphthalene, and methylnaphthalene even when purchased precleaned from the supplier. For reliable PAH analysis, laboratories should develop a screening criteria to test XAD-2 prior to use. Laboratory media blank (LMB) analysis prior to shipment and use for field sampling is recommended.

Use high purity reagents, solvents, and standards to minimize interference problems in sample analysis. Routinely evaluate all these materials to demonstrate that they are either free from interferences under the conditions of the analysis, or that the interference does not compromise the quality of the analysis results. Evaluate chemical interference through the preparation and analysis of an LMB.

4.2 Interferences co-extracted from samples will vary considerably from source to source. Interfering compounds may be present at concentrations several orders of magnitude higher than the target compounds. Because very low levels of target compounds are measured by this method, the elimination of interferences is essential. The cleanup steps given in Section 11.3 provide examples of column-chromatographic cleanup procedures to reduce, but not necessarily eliminate, matrix effects due to high concentrations of organic compounds (International Agency for Research on Cancer 1991) and thereby permit reliable determination of the target compounds at or near estimated MDL level.

4.3 PAH are subject to degradation when exposed to ultraviolet light. Take precautions to shield samples from sunlight or fluorescent light sources during sample collection, recovery, extraction, cleanup, and concentration.

4.4 PAH isomer co-elution may be avoided with the use of a PAH selective GC column; multiple GC column manufacturers offer Select PAH GC columns. Common PAH isomer co-elution include benzo[j]fluoranthene, benzo[b]fluoranthene and benzo[k]fluoranthene, as well as chrysene and triphenylene.

4.5 PCDFE may give a response in the MRM transitions monitored for PCDF; therefore, MRM transitions specific to the chlorodiphenyl ether compounds must be monitored throughout the analytical runs measuring PCDD and PCDF.

4.6 Some PCB congeners give a very small response in the MRM transitions monitored for PCDD/PCDF. If PCB were not eliminated from the extract during the cleanup or, if very high concentrations of PCB in the extract are possible, MRM transitions specific to the PCB can be monitored to ensure that they do not interfere with the quantification of PCDD/PCDF.

5.0 Safety

Note: Laboratories must develop a safety program for the handling of PCDD, PCDF, PCB, and/or PAH.

5.1 The toxicity or carcinogenicity of other reagents or chemicals used in this method is not precisely defined. However, treat each chemical as a potential health hazard and minimize exposure to these chemicals. Exposure to target compounds should be reduced to the lowest possible level.

5.2 Compounds in the PCDD and PCDF classes such as 2,3,7,8-TeCDD are aneugenic, carcinogenic, and teratogenic in laboratory animal studies. Other PCDD and PCDF containing chlorine atoms in positions 2,3,7,8 have toxicities comparable to that of 2,3,7,8-TeCDD.

5.3 PCB are classified as known or suspected human or mammalian carcinogens. Be aware of the potential for inhalation and ingestion exposure.

5.4 This method recommends that the laboratory purchase dilute standard solutions required for this method. However, if preparing primary solutions, use a fume hood or glove box to minimize exposure to vapors. Laboratory personnel handling primary solutions should wear personal protective equipment including a toxic gas respirator mask fitted with charcoal filters approved by the National Institute for Occupational Safety and Health (NIOSH)/Mine Safety Health Administration (MSHA) to prevent the inhalation of airborne particulates if not working in an approved fume hood or glove box.

5.5 The laboratory is responsible for maintaining a current awareness file of Occupational Safety and Health Administration (OSHA) regulations regarding the safe handling of the chemicals specified in this method. Ensure that a reference file or list of internet sites that contain safety data sheets (SDS) is available to all personnel involved in the sampling and chemical analysis of samples known or suspected to contain PCDD, PCDF, PCB, and PAH.

6.0 Equipment and Supplies

Note: Brand names, suppliers, and part numbers are for illustration purposes only and no endorsement is implied. Apparatus and materials other than those specified in this method may achieve equivalent performance. Meeting the performance requirements of this method is the responsibility of the source testing team and laboratory team.

6.1 Sampling Apparatus. Figure OTM 49-1 of this method shows a schematic of the sampling train. Do not use sealing greases or brominated flame retardant-coated tape in assembling the train. Do not use silicon tubing in direct contact with flue gases. The train is identical to that described in Section 6.1.1 of Method 5 of Appendix A-3 to 40 CFR Part 60 with the following additions:

6.1.1 Nozzle. The nozzle must be made of quartz, borosilicate glass or titanium. Stainless steel nozzles should not be used.

6.1.2 Probe Liner. Use either polytetrafluoroethylene (PTFE), borosilicate or quartz glass probe liners with a heating system capable of maintaining a probe gas temperature of 120 ± 14 °C (248 ± 25 °F) during sampling, or such other temperature as specified by an applicable subpart of the standards or as approved by the Administrator. Use a PTFE ferrule or single-use PTFE coated O-ring to achieve the seal at the nozzle end of the probe for stack temperatures up to 300 °C (572 °F). Use a quartz glass liner and integrated quartz nozzle for stack temperatures between 300 and 1,200 °C (572 and 2,192 °F).

6.1.3 Filter Holder. Use a filter holder of borosilicate glass with a PTFE frit or PTFE-coated wire filter support. The holder design should provide a positive seal against leakage from the outside or around the filter. The holder should be durable, easy to load, leak-free in normal

applications, and positioned immediately following the probe and cyclone bypass (or cyclone, if used) with the active side of the filter perpendicular to the source of the flow.

6.1.4 Filter Heating System. Use any heating system capable of monitoring and maintaining the temperature around the filter to ensure that the sample gas temperature exiting the filter is 120 ± 14 °C (248 ± 25 °F) during sampling or such other temperature as specified by an applicable subpart of the standards or approved by the Administrator for a particular application.

6.1.5 Filter Temperature Sensor. Install a temperature sensor capable of measuring temperature to within ± 3 °C (5.4 °F) so that the sensing tip protrudes at least 1.3 centimeters (cm) (1/2 in.) into the sample gas exiting the filter. Encase the sensing tip of the sensor in glass or PTFE, if needed.

6.1.6 Sample Transfer Line. The sample transfer line transports gaseous emissions from the heated filter holder to the condenser and must be heat traced and constructed of glass or PTFE with connecting fittings that form leak-free, vacuum-tight connections without using sealing greases or tapes. Keep the sample transfer lines as short as possible and maintain the lines at a temperature of 120 ± 14 °C (248 ± 25 °F) using active heating when necessary. Orient the sample transfer lines with the downstream end lower than the upstream end so that any condensate will flow away from the filter and into the condenser.

6.1.7 Condenser. Glass, water-jacketed, coil-type with compatible fittings. Orient the condenser to cause moisture to flow down to the adsorbent module to facilitate condensate drainage. Figure OTM49-2 of this method shows a schematic diagram of the condenser.

6.1.8 Water Circulating Bath. Use a bath pump circulating system capable of providing chilled water flow to the condenser and adsorbent module water jackets. Typically, a

submersible pump is placed in the impinger ice water bath to circulate the ice water contained in the bath. Verify the function of this system by measuring the gas temperature at the entrance to the adsorbent module. Maintain this temperature at $< 20\text{ }^{\circ}\text{C}$ ($68\text{ }^{\circ}\text{F}$).

6.1.9 Adsorbent Module. Use a water-jacketed glass container to hold up to 40 grams (g) of the solid adsorbent. Figure OTM49–2 of this method shows a schematic diagram of the adsorbent module. Other physical configurations of the adsorbent resin module/condenser assembly are acceptable if the configuration contains the requisite amount of solid adsorbent and maintains the minimum length-to-width adsorbent bed ratio of two-to-one. Orient the adsorbent module vertically to facilitate condensate drainage. The connecting fittings must form leak-free, vacuum-tight seals. Include a coarse glass frit in the adsorbent module to retain the adsorbent.

6.1.10 Impingers. Use five impingers connected in series with leak-free ground glass fittings or any similar leak-free noncontaminating fittings. The first impinger must be a short-stem (water-dropout) design or equivalent. The second, fourth, and fifth impingers must be of the Greenburg-Smith design, modified by replacing the tip with a 1.3 cm ($1/2$ in.) inside diameter (ID) glass tube extending to approximately 1.3 cm ($1/2$ in.) from the bottom of the flask. The third impinger must be of the Greenburg-Smith design with the standard tip. The second and third impingers must contain known quantities of water, and the fifth impinger must contain a known weight of silica gel or equivalent desiccant. Alternatively, you may omit the first impinger if you do not expect excess moisture in the sample gas.

6.2 Sample Recovery Equipment.

6.2.1 Fitting Caps. Use leak-free ground glass fittings or any similar leak-free noncontaminating fitting to cap the sections of the sampling train exposed to the sample gas.

Alternatively, use PTFE tape or contaminant-free aluminum foil for this purpose (see Section 6.2.6 of this method).

6.2.2 Wash Bottles. Use PTFE bottles.

6.2.3 Probe-Liner, Probe-Nozzle, and Filter-Holder Brushes. Use inert bristle brushes with precleaned stainless steel or PTFE handles. Extensions of the probe brush must be made of stainless steel or PTFE and be at least as long as the probe. Use brushes that are properly sized and shaped to remove accumulated material from the nozzle and probe liner.

6.2.4 Filter Storage Container. Use a sealed filter holder, wide-mouth amber glass jar with PTFE-lined cap, or glass petri dish sealed with PTFE tape. Purchase precleaned amber glass jars and petri dishes or clean according to the glassware cleaning procedures listed in Section 8.1.1.1 of this method.

6.2.5 Field Balance. Use a weighing device capable of measurements to an accuracy of 0.5g.

6.2.6 Aluminum Foil. Use heavy duty aluminum foil cleaned by rinsing three times with hexane or toluene and stored in a pre-cleaned glass petri dish or glass jar. Do not use aluminum foil to wrap or contact filter samples due to the possibility of reaction between the sample and the aluminum.

6.2.7 Silica Adsorbent Storage Containers. Use an air-tight container to store silica gel.

6.2.8 Glass Sample Storage Containers. Recover samples in amber glass bottles, 500- or 1000-milliliters (mL) with leak-free PTFE-lined caps. Either purchase precleaned bottles or clean containers according to glassware cleaning procedures listed in Section 8.1.1.1 of this method.

6.3 Sample Extraction Equipment.

6.3.1 Sample Containers. Use 125- and 250-mL amber glass bottles with PTFE-lined caps.

6.3.2 Test Tubes. Use glass test tubes or small (e.g., 5 to 10 mL) amber vials.

6.3.3 Soxhlet/Dean-Stark Extraction Apparatus.

6.3.3.1 Soxhlet Apparatus. Use 200-mL capacity thimble holder capable of holding 43×123-millimeter (mm) extraction thimbles, with receiving flask (typically round-bottom).

6.3.3.2 Moisture Trap. Use Dean-Stark or Barret with fluoropolymer stopcock trap to fit between the Soxhlet extractor body and the condenser as shown in Figure OTM49-3 of this method. Note: Dean-Stark or Barret traps are used to remove water with extraction solvents that are less dense and insoluble in water.

6.3.3.3 Extraction Thimble. Use quartz, glass, or glass fiber thimble, typically 43 x 123 mm to fit Soxhlet apparatus. The use of cellulose thimbles for sample extraction in this method is prohibited.

6.3.3.4 Heating Mantle. Use a hemispherical shaped heating mantle to fit round-bottom flask.

6.3.4 Kuderna-Danish (KD) Concentrator. Use an apparatus consisting of a three-ball Snyder column, a KD flask with leak-free joint to accept the three-ball Snyder column at the top, a leak-free joint to receive a graduated concentration tube at the bottom and a heating mantle. Note: Rotary evaporation has only been demonstrated when analyzing PCDD/PCDF. The KD with Snyder column is recommended when analyzing for PAH and/or PCB to avoid evaporation loss resulting in failed performance criteria for pre-extraction spike recovery.

6.3.5 Nitrogen Evaporative Concentrator. Use a nitrogen evaporative concentrator equipped with a water bath with the temperature controlled in the range of 30 to 60 °C (86 to 140 °F) (N-Evap Organomation Associates, Inc., South Berlin, MA, or equivalent).

6.3.6 Separatory Funnels. Use glass or PTFE 2-liter separatory funnels.

6.4 Glass Liquid Chromatography Columns.

6.4.1 Pasteur Pipettes. Use disposable pipettes, or glass serological pipettes typically 150 mm long x 6 mm ID.

6.4.2 Liquid Chromatography Columns. 200 to 300 mm long x 20 mm ID with 250-mL reservoir.

6.5 Analytical Equipment.

6.5.1 Gas Chromatograph. Equipped with an oven capable of maintaining the GC column at the proper operating temperature ± 1.0 °C (1.8 °F) and performing programmed increases in temperature at rates of at least 40 °C/min with isothermal hold, an electronic pressure control or equivalent gas metering system to control carrier gas flow or pressure, and a split/splitless injection port in the splitless mode or on-column injection port for the capillary column.

6.5.2 Capillary GC Column. Use different columns for the analysis of the different target compound classes in this method, if needed. Perform the resolution checks in Section 9.2.3 of this method to document the required resolution in Section 9.2.3 and the identification specifications found in Section 9.3 of this method. A confirmation GC column may be used meet the resolution or identification requirements, if needed.

6.5.3 Mass spectrometer. Tandem quadrupole mass spectrometer equipped with either an atmospheric pressure (AP) ionization source or an electron ionization source (70 eV range) capable of repetitively and selectively monitoring at least 32 transitions at unit resolution during

a period of approximately 1 second. The MS/MS must have a mechanism for constantly bleeding perfluorotributylamine (PFTBA) into the source during the analytical run, such as a needle valve or a capillary bleed directly into the source enclosure.

Note: A tandem mass spectrometer in Electron Ionization/MS/MS MRM mode with collision induced dissociation (CID), using 40 to 70 electron volt impact ionization is capable of a mass resolution defined in Section 10.3.1 of this method.

6.5.3.1 MS/MS Data System. An interfaced data system is required to acquire, store, and output MS data. The computer software must have the capability of processing stored data by recognizing a chromatographic peak within a given retention time window. The software must allow integration of the abundance of any specific ion between specified time or scan number limits. The software must be able to reproducibly integrate analyte and labeled standard ion abundances to construct calibration curves and calculate analyte concentrations using the isotope dilution technique.

7.0 Reagents, Media, and Standards

Note: Unless otherwise indicated, all reagents must conform to the *Specifications and Procedures for Reagents and Standard-Grade Reference Materials* (see <https://pubs.acs.org/isbn/9780841230460>) of the American Chemical Society (ACS) Committee on Analytical Reagents where such specifications are available. Other grades may be used if the reagent is demonstrated to be free of analytes and interferences and all requirements in Section 9 are met when using these reagents media and standards.

7.1 Sampling Media.

7.1.1 Filter. Glass or Quartz fiber filters, without organic binder, exhibiting at least 99.95% efficiency (<0.05% penetration) on 0.3-micron dioctyl phthalate smoke particles.

Conduct a QC check on each filter lot prior to the field test by extracting and analyzing a minimum of three filters to demonstrate that filters are free from contamination or interference, criteria in Section 9.2.6.3 of this method.

7.1.2 Adsorbent Resin. Amberlite® XAD–2 resin. Each lot of adsorbent resin must meet the cleanliness criteria in Section 9.2.6.3 of this method following the same extraction, concentration, cleanup, and analysis steps as field samples. This method recommends using the procedures in Appendix B to this method to clean the resin before use, if needed. However, this method allows alternative cleanup procedures, including automated extraction, if the adsorbent meets the required performance criteria. Store adsorbent in a solvent-rinsed nonporous clean container and secure lid.

7.1.3 Glass Wool. Clean the glass wool to meet the specifications in Section 9.2.6.3 of this method. Glass wool dried of the solvent should be stored in a clean glass container with a PTFE-lined screw cap.

7.1.4 Water. Use deionized or distilled water meeting requirements in Section 9.2.6.3 of this method and store in its original container or in a clean glass container with a PTFE-lined screw cap.

7.1.5 Silica Gel. Indicating type for sampling, 6–16 mesh. If previously used, dry at 175 °C (347 °F) for two hours. Use new silica gel as received. As an alternative, use other types of desiccants (equivalent or better), subject to the approval of the Administrator.

7.2 Sample Recovery, Extraction and Cleanup Reagents.

7.2.1 Potassium Hydroxide. American Chemical Society (ACS) grade, 2% (weight/volume) in water.

7.2.2 Sodium Sulfate. Granulated or powdered, reagent grade. Evaluate lot to be free from interferences prior to use.

7.2.3 Sulfuric Acid. Reagent grade.

7.2.4 Sodium Hydroxide. 1.0 N. Reagent grade.

7.2.5 Solvents. Acetone, hexane, methanol, toluene, high-boiling alkanes to use as keeper solvents (tetradecane, nonane, decane); Pesticide grade or better. Evaluate each solvent lot to be free from interferences prior to use.

7.3 Sample Cleanup Materials. The following sample cleanup materials can be used as fit for purpose to prepare sample extracts by fractionation, remove interferences and meet the performance criteria of this method. Commercially prepacked cleaning columns may be available for this purpose. All procedures for preparing and/or packing cleanup materials are recommendations shown to meet the performance criteria required for the recovery of labeled compounds described in Section 9 of this method.

7.3.1 Alumina. Use either acidic or basic alumina in the cleanup of sample extracts. Use the same type of alumina for all samples in an analytical sequence, including those used to demonstrate LMB performance.

7.3.2 Acid Alumina (Sigma-Aldrich® 199966 or equivalent). Brockmann activity grade 1, 100–200 mesh. Prior to use, activate the alumina by heating for 12 hours at 130 °C (266 °F). Store in a desiccator. You may use pre-activated alumina purchased from a supplier as received.

7.3.3 Basic Alumina (Sigma-Aldrich® 19943 or equivalent). Brockmann activity grade 1. Activate by heating to 600 °C (1,112 °F) for a minimum of 24 hours. Do not heat to over 700 °C (1,292 °F) because this can lead to reduced capacity for retaining the target compounds. Store at

130 °C (266 °F) in a covered flask. Use within five days of baking. Use prepacked alumina columns immediately after opening the vacuum sealed pouch or container.

7.3.4 Florisil®. Activated, 60–100 mesh recommended. Heat previously activated Florisil® in a glass container loosely covered with aluminum foil in an oven at 130 to 150 °C (266 to 302 °F) for a minimum of 24 hours. Allow to cool and store activated Florisil® silica in a desiccator.

7.3.5 Silica Gel. Use either activated, acidic or basic silica gel in the cleanup of sample extracts. Use the same type of silica gel for all samples in an analytical sequence, including those used to demonstrate LMB performance.

7.3.6 Activated Silica Gel. Supelco® 1-3651, Bio-Sil® A, 100–200 mesh (or equivalent). Prior to use, it is recommended to rinse with methylene chloride and activate the silica gel by heating for at least 1 hour at 180 °C (356 °F). After allowing to cool, rinse the silica gel sequentially with methanol and toluene. Heat the rinsed silica gel at 50 °C (122 °F) for 10 minutes, then increase the temperature gradually to 180 °C (356 °F) over 25 minutes and maintain the gel at this temperature for 90 minutes. Allow to cool in a desiccator to room temperature and store in a glass container with a PTFE-lined screw cap. Alternative conditioning procedure may be used if the performance criteria in Section 9 are met for target compounds.

7.3.7 Acid Silica Gel (30% weight/weight). Combine 100 g of activated silica gel with 44 g of concentrated sulfuric acid in a clean screw-capped glass container and agitate thoroughly. Disperse the solids with a stirring rod until obtaining a uniform mixture. Store the mixture in a glass container with a PTFE-lined screw cap.

7.3.8 Basic Silica Gel. Combine 30 g of 1 N sodium hydroxide with 100 g of activated silica gel in a clean screw-capped glass container and agitate thoroughly. Disperse solids with a

stirring rod until obtaining a uniform mixture. Store the mixture in glass container with a PTFE-lined screw cap.

7.3.9 Carbon/Celite® 545 (or equivalent solid support). Use of a carbon-based column cleanup material (e.g., one of the many including for example Carbopack® B or C) to further remove non-planar impurities from the samples prior to analysis may be necessary. You must evaluate alternative carbon-based sorbents for this purpose prior to their use. An 18% weight/weight mixture of Carbopack® C and Celite® 545 has been used for this purpose and should be activated at 130 °C (266 °F) for a minimum of 6 hours. Allow to cool and store this mixture in a desiccator.

7.3.10 Nitrogen. 99.999% (ultra-high) purity.

7.4 Sample Analysis Reagents.

7.4.1 Spiking Standards. Prepare spiking standards quantitatively at a convenient concentration (e.g., 10 nanograms (ng)/mL) or use commercial standards if available, to enable accurate spiking of a labeled standard at various stages of the sample and extract preparation. You may adjust the sample fortification concentrations from those recommended in Tables OTM49-7, OTM49-8, and OTM49-9 of this method to accommodate the concentration of target compounds anticipated in samples if the performance criteria in Section 9 of this method are met.

Note: When adjusting the fortification concentrations in the final sample extract, consider variables such as the aliquot of extract used and injection volume of samples and calibration.

7.4.2 Pre-Sampling Adsorbent Standard. Prepare stock standard solutions in nonane to enable spiking of the isotopically labeled compounds at the concentration in the final sample extract shown under the heading “Pre-sampling Adsorbent Standard” in Tables OTM49-7,

OTM49-8, and OTM49-9 of this method (Tables OTM49-11, OTM49-12, and OTM49-13 for calibration standards), for applicable target compound classes.

7.4.3 Pre-extraction Filter Recovery Standard. Prepare stock standard solutions in nonane to enable spiking of the isotopically labeled compounds at the concentration in the final sample extract shown under the heading “Pre-extraction Filter Recovery Standard” in Tables OTM49-7, OTM49-8, and OTM49-9 of this method (Tables OTM49-11, OTM49-12, and OTM49-13 for calibration standards), for applicable target compound classes.

7.4.4 Pre-extraction Standard. Prepare stock standard solutions in nonane to enable spiking of the isotopically labeled compounds at the concentration in the final sample extract shown under the heading “Pre-extraction Standard” in Tables OTM49-7, OTM49-8, and OTM49-9 of this method (Tables OTM49-11, OTM49-12, and OTM49-13 for calibration standards), for applicable target compound classes.

7.4.5 Pre-analysis Standard. Prepare stock standard solutions in nonane to enable spiking of the isotopically labeled compounds at the concentration in the final sample extract shown under the heading “Pre-analysis Standard” in Tables OTM49-7, OTM49-8, and OTM49-9 of this method (Tables OTM49-11, OTM49-12, and OTM49-13 for calibration standards), for applicable target compound classes.

7.4.6 Native Target Compound Calibration Stock Standard. Prepare stock standard solution of native target compounds in nonane at sufficient concentration when diluted and combined with isotopic labeled compounds to cover the range of concentrations shown in Tables OTM49-11, OTM49-12, and/or OTM49-13 or to bracket the range of concentrations fit for the purpose of the supported field test.

7.4.7 Combine the solutions in Sections 7.4.2 through 7.4.6 to prepare at least five calibration solutions at the suggested concentrations shown in Tables OTM49-11, OTM49-12, and/or OTM49-13. The Cal 3 from Tables OTM49-11, OTM49-12, and/or OTM49-13 will be used as the CCC standard for applicable target compound classes.

8.0 Sample Collection, Preservation, and Storage

8.1 Sampling. This method involves collection and recovery of trace concentrations of target semivolatile organic compounds. Therefore, field sampling and recovery staff should be trained and experienced in the best practices for handling and using organic solvents in field environments to recover and protect samples from contamination.

8.1.1 Pretest Preparation.

8.1.1.1 Cleaning Glassware. Clean glassware thoroughly before using. This section provides a recommended procedure, but any protocol that consistently results in contamination-free glassware meeting the LMB criteria in Section 9.2.6.3 of this method is acceptable.

8.1.1.1.1 Soak all glassware in hot soapy water (Alconox® or equivalent).

8.1.1.1.2 Rinse with hot tap water.

8.1.1.1.3 Rinse with deionized/distilled water.

8.1.1.1.4 Rinse with methanol.

8.1.1.1.5 Rinse with toluene.

8.1.1.1.6 Baking glassware up to 400 °C (752 °F) for a minimum of 2 hours may be necessary to remove contaminants or interferents from particularly dirty samples. Allow glassware to cool after baking.

Note: Repeated baking of glassware may cause active sites on the glass surface that may irreversibly absorb target compounds.

8.1.1.1.7 Cover glassware openings with clean glass fitting caps or cleaned aluminum foil (see Section 6.2.6 of this method).

8.1.1.1.8 Rinse glassware immediately before use with acetone and then toluene.

Note: To prepare heavily soiled glassware, remove surface residuals from the glassware by soaking in hot soapy water, rinsing with hot water, then soaking with a non-chromic acid oxidizing cleaning reagent in a strong acid (e.g., NOCHROMIX® prepared according to manufacturer's directions). After the acid soak, rinse with hot water and repeat the cleaning procedures in Section 8.1.1.1 of this method.

8.1.1.2 Adsorbent Module. Load the modules in a clean area to avoid contamination. Fill a module with 20 to 40 g of XAD-2. Spike modules before the sampling event, but do not spike the modules in the field. Add the pre-sampling adsorbent standard to the top quarter of the adsorbent bed rather than onto the top or bottom of the adsorbent bed. Add sufficient spike (picograms (pg)/module) to result in the final sample theoretical concentrations specified in Tables OTM49-7, OTM49-8, and OTM49-9 of this method for PCDD/PCDF, PAH, and PCB, respectively, and to be above the lowest calibration concentration to ensure the standard recovery is quantitative. For samples with known or anticipated target compound concentration significantly higher or lower than the specified concentration in these tables, adjust the pre-sampling adsorbent standard concentration to the expected native compound concentration, but no less than 10 times the MDL. Follow the XAD-2 with cleaned glass wool and seal both ends of the module tightly with glass caps. For analysis that include PAH, use spiked modules within 14 days of preparation. See Table OTM49-10 of this method for storage conditions.

8.1.1.3 Sampling Train. Figure OTM49-1 of this method shows the complete sampling train. Follow the best practices by maintaining all sampling train components according to the

procedure described in APTD-0576 Maintenance, Calibration, and Operation of Isokinetic Source-sampling Equipment (U.S. EPA 1972).

8.1.1.4 Silica Gel. Weigh several 200 to 300 g portions of silica gel in an air-tight container to the nearest 0.5 g. Record the total weight of the silica gel plus container on the outside of each container. As an alternative, directly weigh the silica gel in its impinger or sampling holder just prior to sampling.

8.1.1.5 Filter. Check each filter against light for irregularities and flaws or pinhole leaks. Pack the filters flat in a clean glass container. Do not mark filters with ink or any other contaminating substance.

8.1.2 Preliminary Determinations. Use the procedures specified in Section 8.2 of Method 5 of Appendix A-3 to 40 CFR Part 60.

8.1.2.1 Sample Volume. Unless otherwise specified in an applicable rule, regulation, or permit, sample for a minimum of 2 minutes at each traverse point. This method recommends sampling a minimum of 2.5 dry standard cubic meters (dscm).

8.1.2.2 For continuously operating processes, use the same sampling time at each traverse point. To avoid timekeeping errors, use an integer, or an integer plus one-half minute, for each traverse point.

8.1.2.3 For batch processes, determine the minimum operating cycle duration, dividing the sampling time evenly between the required numbers of traverse points. After sampling all traverse points once, sample each point again for the same duration of time per sampling point in reverse order until the operating cycle is completed. Sample all traverse points at least once during each test run.

8.1.3 Preparation of Sampling Train.

8.1.3.1 During field preparation and assembly of the sampling train, keep all train openings where contamination can enter sealed until just prior to assembly or until sampling is about to begin. To protect the adsorbent module from radiant heat and sunlight, you must wrap the module with aluminum foil or other suitable material capable of shielding the module from light. The XAD-2 adsorbent resin temperature must never exceed 50 °C (122 °F) because thermal decomposition will occur. Prepare a complete set of sampling train components that will contact the sample for each sampling run, including one complete clean set to be used as a field train proof blank (FTPB) as a tool to evaluate equipment preparation and potential contamination during sample recovery as described in Section 9.1.3 of this method.

8.1.3.2 Place approximately 100 mL of water in the second and third impingers but leave the first and fourth impingers empty. Transfer approximately 200 g or more of silica gel from its container to the fifth impinger. Weigh each impinger and the adsorbent module, including the fitting caps, to the nearest 0.5 g using the field balance and record the weight for moisture determination. Remove the aluminum foil from the adsorbent module before weighing. Keep the module out of direct sunlight and rewrap the module with foil immediately after recording the module weight.

8.1.3.3 Using tweezers or clean disposable surgical gloves, place a filter in the filter holder. Be sure that the filter is properly centered, and the gasket properly placed, to prevent the sample gas stream from circumventing the filter. Check the filter for tears after completing the assembly.

8.1.3.4 Prepare the inside of the sampling probe and nozzle by brushing each component while rinsing three times each with acetone and toluene. Install the selected nozzle, using the connecting systems described in Section 6.1.2 of this method. Mark the probe with heat resistant

tape or by some other method to denote the proper distance into the stack or duct for each sampling point. Assemble the train as shown in Figure OTM49–1 of this method. Orient the adsorbent module vertically so condensed moisture drains into the first impinger. See APTD-0576 Maintenance, Calibration, and Operation of Isokinetic Source-sampling Equipment (U.S. EPA 1972) for details.

8.1.3.5 Turn on the recirculation pump to the adsorbent module and condenser coil and begin monitoring the temperature of the gas entering the adsorbent module.

8.1.4 Leak-Check Procedure. Same as Section 8.4 of Method 5 of Appendix A-3 to 40 CFR Part 60.

8.1.5 Sampling Train Operation. Same as Sections 8.5.1 through 8.5.9 of Method 5 of Appendix A-3 to 40 CFR Part 60.

8.1.5.1 Monitor the filter temperature sensor and record the filter temperature during sampling to ensure a sample gas temperature exiting the filter of $120\text{ }^{\circ}\text{C} \pm 14\text{ }^{\circ}\text{C}$ ($248\text{ }^{\circ}\text{F} \pm 25\text{ }^{\circ}\text{F}$), or such other temperature as specified by an applicable subpart of the standards or approved by the Administrator for an application of this method.

8.1.5.2 During testing, you must record the temperature of the gas entering the XAD-2 adsorbent module. The temperature of the gas must not exceed $20\text{ }^{\circ}\text{C}$ ($68\text{ }^{\circ}\text{F}$) for efficient capture of the target compounds.

8.2 *Sample Recovery*. Begin the cleanup procedure as soon as the probe is removed from the stack at the end of the sampling period. Seal the nozzle end of the sampling probe with PTFE tape or clean (e.g., toluene rinsed) aluminum foil. This method recommends using clean glassware prepared following Section 8.1.1.1 of this method for each sample set in a test series.

8.2.1 When the probe can be safely handled, wipe off all external particulate matter near the tip of the probe. Conduct a post-test leak check. Remove the probe from the train and close off both ends with PTFE tape or clean aluminum foil. Seal off the inlet to the train with PTFE tape, a ground glass cap, or clean aluminum foil.

8.2.2 Transfer the probe and impinger assembly to the cleanup area. This method recommends cleaning and enclosing this area to minimize the chances of losing or contaminating the sample. To avoid sample contamination and unnecessary exposure to toxic chemicals, smoking or eating in the sample recovery area shall not be allowed.

8.2.3 Inspect the train prior to and during disassembly. Note and record any abnormal conditions (e.g., broken filters, colored impinger liquid). Recover and prepare samples for shipping as follows in Sections 8.2.4 through 8.2.12 of this method.

8.2.4 Container No. 1. Either seal the filter holder or carefully remove the filter from the filter holder and place it in its identified container. If it is necessary to remove the filter, use a pair of cleaned tweezers to handle the filter. If necessary, fold the filter such that the particulate cake is inside the fold. Carefully transfer to the container any particulate matter and filter fibers that adhere to the filter holder gasket by using a dry inert bristle brush and a sharp-edged blade. Seal the container and store cool ($\leq 20 \pm 3$ °C, 68 ± 5 °F) for transport to the laboratory.

8.2.5 Adsorbent Module Sample. Remove the module from the train, tightly cover both ends with fitting caps and PTFE tape, remove the foil, drain the recirculating water from the module, weigh and record the module weight, and label the adsorbent module. Moisture measurement in the field using the sample train requires weighing the adsorbent module before and after the sampling run and sampling as part of the sample recovery. Adsorbent modules are

weighed with the same inlet and outlet covering used to contain the module contents during shipping.

8.2.6 Container No. 2. Quantitatively recover material deposited in the nozzle, the probe, the front half of the filter holder, and the cyclone, if used, by brushing while rinsing three times with acetone followed by three rinses with toluene. Collect all the rinses in Container No. 2.

8.2.7 Rinse the back half of the filter holder three times with acetone followed by three rinses with toluene. Rinse the sample transfer line between the filter and the condenser three times with acetone followed by three rinses with toluene. If using a separate condenser and adsorbent module, rinse the condenser three times with acetone followed by three rinses with toluene. Collect all the rinses in Container No. 2 and mark the level of the liquid on the container.

8.2.8 Moisture Weight. Weigh the adsorbent module, impingers, and silica gel impinger to within ± 0.5 g using the field balance and record the weights. This information is required to calculate the moisture content of the effluent gas. For PCDD/PCDF-only measurements, discard the liquid after measuring and recording the weight.

8.2.9 Container No. 3. You must save and analyze impinger water samples if PAH and/or PCB are the target compounds. Quantitatively recover impinger water samples for analysis if PAH and/or PCB are the target compounds by rinsing three times with acetone followed by three rinses with toluene. Collect impinger water and rinses in Container No. 3 and mark the level of the liquid on the container. Impinger rinses may be collected in a separate container with instructions to combine during laboratory preparation.

8.2.10 Silica Gel. Note the color of the indicating silica gel to determine if it has been completely spent and report its condition on the field data sheet.

8.2.11 Field Sample Handling, Preservation, Storage, and Transport. Store all field samples temporarily in cool ($\leq 20\text{ }^{\circ}\text{C}$, $68\text{ }^{\circ}\text{F}$) and dark conditions prior to transport to the laboratory. Ship samples cool ($\leq 20\text{ }^{\circ}\text{C}$, $68\text{ }^{\circ}\text{F}$) and shielded from ultraviolet light. In addition, follow the procedures in American Society for Testing and Materials (ASTM) D6911-15 (Guide for Packaging and Shipping Environmental Samples for Laboratory Analysis) for all samples, where appropriate. To avoid contamination of the samples, pay special attention to cleanliness during transport, field handling, sampling, recovery, and laboratory analysis, as well as during preparation of the adsorbent cartridges.

8.2.12 Sample Custody. Proper procedures and documentation for sample chain of custody are critical to ensuring data integrity. Follow the chain of custody procedures in ASTM D4840-99(2018)e1 (Standard Guide for Sampling Chain-of-Custody Procedures) for all samples (including field samples and blanks).

8.3 Sample Storage Conditions and Laboratory Hold Times.

8.3.1 Table OTM49-10 of this method summarizes the sample storage conditions and laboratory hold times.

8.3.2 Store sampling train rinses and filter samples in the dark at the storage conditions in Table OTM49-10 from the time the laboratory receives the samples until analysis.

8.3.3 You may store adsorbent samples for PCDD/PCDF or PCB analysis prior to extraction in the dark at $6\text{ }^{\circ}\text{C}$ ($43\text{ }^{\circ}\text{F}$) or less for up to one year from the time the laboratory receives the samples.

Note: The hold times listed in this method for adsorbent samples for PCDD/PCDF and PCB are recommendations as these compounds are very stable under the conditions listed in this section.

8.3.4 Protect adsorbent samples destined for PAH analysis from ultraviolet light. You may store adsorbent samples for PAH analysis at 6 °C (43 °F) or less for up to 30 days from the time the laboratory receives the samples.

8.3.5 Analyze PAH extracts within 45 days of extraction.

8.3.6 You may store sample aliquots including archived extracts of PCDD/PCDF, PAH and/or PCB samples in the dark at -10 °C (14 °F) or less for up to one year.

Note: The hold times listed in this method for sample aliquots for PCDD/PCDF and PCB analysis are recommendations as these compounds are very stable under the conditions listed in this section. Extracts must not be stored with pierced septa.

9.0 Quality Control

This section describes quality control parameters, the required frequency of quality control procedures, and the performance criteria that must be met to satisfy method objectives. The analysis QC criteria discussed in the following sections are summarized in Table OTM49-19. These QC requirements are considered the minimum for an acceptable QC program. Laboratories are encouraged to institute additional QC practices to meet their specific needs. Laboratories must evaluate changes made within the flexibility allowed in this method to re-demonstrate that the method specific performance criteria are achieved. See Section 9.6.1 of this method for examples of method changes that require re-demonstration. Each testing team that uses this method is required to operate a formal quality assurance program. It is the testing team's responsibility to establish the conditions for optimum sample collection, extraction, cleanup, concentration, and analysis to meet the performance criteria in this method.

In recognition of advances that are occurring in sampling and analytical technology, and to allow the test team to overcome analyte sensitivity and matrix interferences, this method

allows certain options to increase sample collection volume, to improve separations and the quality of the analysis results for target analytes. These options include alternate extraction, concentration, cleanup procedures, and chromatographic columns. However, you may not change the fundamental sampling and analysis techniques, isokinetic sampling with an adsorbent collection media followed by sample extraction, GC-MS/MS detection and isotopic dilution quantification procedures.

9.1 Sampling Quality Control.

9.1.1 Sampling System. Same as Sections 8.4 and 9.2 of Method 5 of Appendix A-3 to 40 CFR Part 60.

9.1.2 Sampling Media Quality Control.

9.1.2.1 Section 9.2.6.3 of this method includes the performance criteria for lot blank evaluation samples. Failure to meet these levels does not invalidate data. However, the measured target compound mass in each lot blank sample will need to be reported and used to interpret sample results.

9.1.2.2 Filter and XAD-2 media quality control check. Conduct a filter and XAD-2 lot blank check prior to the field test to demonstrate that filters are free from contamination or interference. Perform extraction and analysis using the same procedures used to process field samples as outlined in Section 11 of this method on a minimum of three filters from the lot, including the addition of pre-extraction filter recovery, pre-extraction, and pre-analysis standards. The lot blank checks must meet the performance requirements in Section 9.2.6.3 of this method. Ongoing analysis of the combined filter and XAD-2 sorbent blank (LMB) can be used to fulfill this check. If criteria are not met for target compounds, filters and sorbent lot blank

checks must be performed independently to identify the source of the blank and replace or reclean the contributing media.

9.1.3 Field Train Proof Blank (FTPB). A FTPB consists of a fully assembled train at the sampling site, without actual sampling. The FTPB train uses glassware from the same preparation batch as the field samples. Prepare and assemble the FTPB in a manner identical to that described in Section 8.1.3 and 8.1.4 of this method. The FTPB is taken to the sampling area, and leak checked at the beginning and end of the testing (or for the same total number of times as the actual test train). The filter housing and probe of the blank train is heated during the sample test. No gaseous sample is passed through the sampling train. Recover the blank train as an actual train described in Section 8.2 of this method. Follow all subsequent steps for blank train sample preparation and analysis used for field train samples including data reporting. A FTPB must be submitted with the samples collected at each sampling site to evaluate equipment preparation and potential contamination during sample recovery. At a minimum, conduct at least one FTPB for each test series at a single facility. The FTPB must meet the performance requirements in Section 9.2.6.3 of this method.

9.2 Analysis Quality Control.

9.2.1 It is the laboratory's responsibility to establish the conditions for optimum sample extraction, cleanup, concentration, and analysis to meet the performance criteria in this method. The analysis performance criteria in this method establish the minimum criteria to ensure that options employed for analysis of a sample set for analytes of interest generated reliable data. The minimum requirements of this program consist of the IDC and ongoing QC requirements. The analysis team shall perform an initial demonstration of the capability to demonstrate acceptable accuracy and precision with this method.

9.2.2 Initial Demonstration of Capability (IDC). The IDC must be successfully performed prior to analyzing field samples. Prior to conducting the IDC, the analyst must meet the calibration requirements outlined in Section 10. The same calibration range used during the IDC must be used for the analysis of field samples. Results from the IDC must meet the QC requirements in Table OTM49-18.

9.2.2.1 Demonstration of Precision. Prepare, extract, and analyze seven replicate LFMBs in a valid Extraction Batch (seven LFMBs and an LMB). Fortify the LFMBs near the midpoint of the initial calibration curve. The percent relative standard deviation (%RSD) of the concentrations from the replicate analyses must be less than 20% for all method analytes. Demonstration is repeated for failed compounds only.

9.2.2.2 Demonstration of Accuracy. Using the same set of replicate data generated for Section 9.2.2.1, calculate the average percent recovery. The average recovery for each analyte must be within a range of 70–130%. Demonstration is repeated for failed compounds only.

9.2.2.3 Lowest Calibration Concentration Confirmation. Establish a target concentration for the lowest calibration standard based on the intended use of the method. The lowest calibration concentration may be established by a laboratory for their specific purpose or may be set by a regulatory agency. If there is a regulatory or programmatic lowest quantitative reporting requirement, the laboratory calibration curve must be set at or below this level. In doing so, the laboratory's ability to measure analyte concentrations down to the lowest calibration point must be confirmed.

9.2.2.3.1 Calculate Lowest Calibration Concentration Statistics. Calculate the Upper and Lower Limits for the Prediction Interval of Results (Equations OTM49-14 and OTM49-15). The criterion for the Upper PIR Limit is less than, or equal to 150% and for the Lower PIR Limit is

greater than, or equal to, 50%. If these criteria are not met, the lowest calibration point has been set too low and must be confirmed again at a higher concentration.

9.2.2.3.2 Demonstration of Low System Background. Analyze an LMB after the highest standard in the calibration range. If an automated extraction system is used, an LMB must be extracted on each port. Performance criteria are presented in Section 9.2.6.3.

9.2.2.4 Initial MDL Determination. Perform an MDL determination using a combined filter/sorbent media blank (LMB) following the requirements in 40 CFR Part 136 Appendix B. The MDL determination includes seven (7) LMBs and seven (7) LFMBs that are prepared from clean media and processed in a manner identical to field samples. The LFMBs are spiked within 2 to 10 times of the expected MDL. The MDL study establishes the lowest detectable concentrations for each sampling train fraction. Sample specific MDLs are reported inclusive of sample-specific dilutions, final volumes, aliquots, etc.

9.2.2.4.1 MDL Confirmation. Prepare a LFMB for a combined filter/sorbent media sample by spiking clean sorbent with native target compounds at the level of the determined MDL and the same isotopically labeled standards used to analyze field samples. Prepare and analyze the spiked LFMB and confirm target compounds meet the qualitative identification criteria in Section 9.3 of this method.

9.2.2.5 Quality Control Sample (QCS). A QCS is analyzed during the IDC and following each initial calibration (at a minimum quarterly) thereafter to verify the accuracy of the primary initial calibration standards. For this method, the laboratory is not required to obtain standards from a source independent of the primary calibration standards. Instead, the laboratory should acquire the best available quantitative standards and use these to prepare both the primary calibration standards and the QCS. Preparation by a second analyst is recommended. The

acceptance criterion for the QCS is 70 to 130% of the true value. If the accuracy for any analyte fails the recovery criterion, prepare fresh standard dilutions and repeat the initial calibration verification.

9.2.3 GC column systems used must be able to achieve required separation. Failure to meet this chromatographic resolution criterion requires corrective action and recalibration prior to a subsequent column resolution check. A mid-concentration standard containing all the native target compounds may be used to demonstrate this requirement.

9.2.3.1 PCDD/PCDF Column. Gas chromatographic columns used to measure PCDD/PCDF should be capable of achieving separation of the 17 PCDD/PCDF target compounds from the nearest eluting target compound(s). The separation of all 2,3,7,8-specific isomers must be demonstrated whether a dual-column or a single-column analysis is chosen. The valley height between 2,3,7,8-TeCDF and the other tetra-furan isomers must not exceed 40% of the taller of the two peaks. The valley height between 2,3,7,8-TeCDD and the other tetra-dioxin isomers must not exceed 40% of the taller of the two peaks.

Note: Fishman, et al. (see Section 16.3 of this method) demonstrated that all TEF isomers can be fully differentiated from closely eluting isomers using either of two sets of non-polar and polar stationary phase combinations. One set consisted of 5% phenyl methylpolysiloxane (DB-5, HP-5MS, Rtx-5MS, Equity-5) and 50% cyanopropylmethyl, 50% phenylmethylsiloxane (DB-225, SP 2331) GC columns and the other set consisted of 5% phenyl, 94% methyl, 1% vinyl silicone bonded-phase (DB-5MS, ZB-5MS, VF-5MS, CP-Sil 8 CB LowBleed/MS) with 50% cyanopropylmethyl, 50% phenylmethylsiloxane (SP-2331).

9.2.3.2 PAH Column. Use column systems for measuring PAH that can achieve separation of anthracene and phenanthrene at m/z 178 such that the valley between the peaks does not exceed 50% of the taller of the two peaks, and benzo[*b*]fluoranthene and benzo[*k*]fluoranthene such that the valley between the peaks is less than 60% of the height of the taller peak. These requirements are achievable using a 30-m narrow bore (0.25 mm ID) 5% phenyl polysilphenylene-siloxane (BPX5 or equivalent) bonded-phase, fused-silica capillary column.

9.2.3.3 PCB Column. Use column systems for measuring PCB that can achieve unique resolution and identification of the toxics for determination of a TEQ_{PCB} using toxic equivalency factors (TEF). Resolution is shown by a valley between the peaks not exceeding 40% of the taller of the two peaks. Isomers may be unresolved if they have the same TEF and response factor and if these unresolved isomers are uniquely resolved from all other congeners. These requirements are achievable using several 30-meter (m) narrow bore (0.25 mm ID) columns including 8% phenyl polycarborane-siloxane (HT8), DB-XLB, and poly (50% *n*-octyl/50% methyl siloxane) (SPB-Octyl). Quantification of unresolved isomers should use the nearest eluting target PCB pre-extraction standard in Appendix A of this method, unless otherwise specified in applicable rule, regulation, or permit.

Note: If all 209 PCB are analyzed the 17 toxic PCB congeners should be resolved and reported while the other PCB can be reported as totals by homolog, for example, total TrCB.

9.2.4 Initial Calibration. Perform an initial calibration following the procedures in Section 10.5. The initial calibration acceptance criteria are:

- For each calibration level, the result for each target analyte must be 70 to 130% of the true value (for Cal 1, 50 to 150% of the true value).

- The RSD for average RRF from each of the target analytes and labeled standards in the calibration samples must not exceed the values in Table OTM49-14 of this method.
- The S/N in every selected ion current profile must be ≥ 10 for all unlabeled targets and labeled standards in the calibration samples.
- The transition ion ratios must be within the control limits in Table OTM49-15 of this method.
- Labeled standards in each calibration standard must meet criteria in Section 9.2.7 of this method.
- Initial calibration verification, QCS, results for each of the target analytes must be 70 to 130% of the true value.

9.2.4.1 Corrective Action. If these initial calibration criteria cannot be met, the analyst could have difficulty meeting continuing calibration check criteria. In this case, corrective action is recommended such as reanalyzing the calibration standards, restricting the range of calibration, or performing instrument maintenance. If the cause for failure to meet the criteria is due to contamination or standard degradation, prepare fresh calibration standards and repeat the initial calibration.

9.2.5 Continuing Calibration Check (CCC). Analyze CCC standards at the beginning of each Analysis Batch, after every tenth field sample, and at the end of the Analysis Batch. Initial CCC must be at or below QRL concentration and subsequent CCCs may be at mid- or high-level concentrations.

Note: If standards have been prepared such that all low calibration levels are not in the same solution, it may be necessary to analyze multiple standards to meet this requirement.

Alternatively, the nominal analyte concentrations in the analyte PDS may be customized to meet these criteria.

- Each CCC analyte fortified at the lowest initial calibration level (Cal 1, at or below QRL) must be 50 to 150% of the true value. Other CCCs must have an analyte recovery 70 to 130% of true value.
- Each analyte RRF from the CCC must meet the criteria in Table OTM49-14 when compared to the corresponding average RRF from the initial calibration.
- The labeled standards in the CCC standard must meet criteria in Section 9.2.7 of this method.
- The transition ion ratios must be within the control limits in Table OTM49-15 of this method.

9.2.5.1 Corrective Action. If the CCC fails because concentration is >130% (150% for low-level CCC) and field sample extracts show no concentrations above the MDL for that analyte, non-detects can be reported without re-analysis. If these limits are otherwise exceeded, then all data for the failed analytes must be considered invalid. Any field samples analyzed since the last acceptable CCC that are still within holding time must be reanalyzed after an acceptable calibration check has been restored.

Failure to meet the CCC criteria requires corrective action. Following a minor remedial action, such as servicing the autosampler or ramping the GC column oven temperature to the maximum run temperature and flushing residual sample you may check the calibration with a mid-level CCC and a CCC at the QRL. If pre-analysis standard and/or calibration failures persist, maintenance may be required, such as servicing the GC-MS/MS system or replacing the GC

column. These latter measures constitute major maintenance, and the analyst must return to the initial calibration step.

9.2.5.2 Column Separation Check. Use the results from a CCC sample to verify and document the resolution required in Section 9.2.3 of this method for the compound classes analyzed with this method.

9.2.5.3 If a confirmation column is used, perform the resolution check in Section 9.2.3 of this method to document the required resolution on the confirmation column for the applicable target compounds.

9.2.6 Analysis and Media Blanks

9.2.6.1 Blanks and Background Levels. The quantitative measurement of various blanks and sampling media background levels is required.

9.2.6.2 Sampling Media Background Level Checks. When performing cleanliness checks on the sampling media prior to field sampling (i.e., filters, XAD-2, reagents, solvents, etc), acceptable levels should be at or less than the established MDLs. If blank concentrations are found above the MDL, reclean the sampling media until their blank levels meet the blank criteria. This check can be accomplished with LMB.

9.2.6.3 Laboratory Method Blank (LMB). Analyze at least one LMB during an analytical sequence or every 12 hours, whichever is shorter. If multiple LMB are required for an analytical sequence, report the initial LMB that pairs with each 12-hour analysis period. Sampling media and reagents are fortified with the pre-extraction standards and processed identically to a field sample of the same media. LMBs for each sampling media and reagent (i.e., filter, XAD-2, glass wool, water, rinsing solutions) are included in each Extraction Batch to determine if the method analytes or other interferences are introduced from the laboratory environment, the reagents,

glassware, or extraction apparatus. Acceptable levels should be no greater than the MDL. If method analytes are detected in the LMB at concentrations greater than the MDL, the results must be compared to the compliance or data quality required by the measurement. If the LMB results are one tenth of the compliance or required data quality level or less then report results as measured. If LMB results for a sample batch are greater than ten percent of the compliance or applicable regulatory limit results are flagged as failing this method's requirements. Root cause analysis and corrective action should be taken for LMB failures prior to analyzing additional samples.

9.2.6.4 Influence of Background on Selection of MDLs. Because background contamination (e.g., FTPB concentration) can be a significant limitation to quantitative results, MDLs can be no lower for a set of field samples than the corresponding blank concentration measured in the FTPB.

9.2.6.5 Evaluation of Background when Analytes Exceed the Calibration Range. After analysis of a sample in which method analytes exceed the calibration range, one or more LMBs must be analyzed (to detect potential carryover). If the analytes that exceeded the calibration range in the previous sample are detected at, or above, the QRL in the subsequent LMB, subsequent samples are invalid and must be reanalyzed. If the affected analytes do not exceed the QRL, subsequent samples may be reported.

9.2.6.6 Laboratory Fortified Media Blanks (LFMB). Duplicate low level and high level LFMBs are required with each extraction batch for each media fraction (i.e., filter, XAD-2, water).

9.2.6.6.1 LFMB Concentration Requirements. Fortify the low concentration LFMB no more than two times the lowest calibration point. Fortify the high level LFMBs at a concentration between the mid and high-level calibration points.

9.2.6.6.2 Evaluate Analyte Recovery. Calculate the percent recovery (%R) using Equation OTM49-9. To obtain meaningful percent recovery results, correct the measured values in the LFMB and LFMB duplicate for the native levels in the LMB, even if the native values are less than the lowest calibration concentration.

Results for analytes fortified at concentrations near or at the lowest calibration point (within a factor of two times the lowest calibration concentration) must be 50 to 150% of the true value. Results for analytes fortified at higher concentrations must be 70 to 130% of the true value. If the LFMB results do not meet these criteria, then report all data for the problem analytes in the Extraction Batch with a note that the LFMB accuracy criteria were not met. The laboratory must investigate the root cause for this failure and report their findings and corrective action.

9.2.7 Labeled Standard Recoveries

9.2.7.1 Pre-sampling Adsorbent Standard and Pre-extraction Filter Recovery Standard Recoveries. The use of pre-sampling adsorbent standards added to XAD-2 collection media prior to sampling and analyzed in the same manner as targeted compounds serves as an indication of the method's quantitative capture efficiency. Pre-sampling adsorbent standard and pre-extraction filter recovery standard must demonstrate recovery on a per sampling train basis between 70 and 130% (Tables OTM49-7, OTM49-8, and OTM49-9 of this method). Recoveries below the acceptable range for the pre-sampling adsorbent standard indicate breakthrough in the sampling train and require a root cause evaluation of the poor recovery before the sampling and analysis is

repeated. If the recovery of all the pre-sampling adsorbent standard is below 70%, the sampling runs are not valid, and you must repeat the stack tests for invalid runs. If the recovery of the pre-extraction filter recovery standard is below 70%, the filter sampling recovery is not valid, and you must identify the root cause of the failure and retest the stationary source.

9.2.7.2 Pre-extraction Standard Recoveries. For QC purposes, the percent recoveries of the pre-extraction standards are calculated using the integrated peak areas of pre-analysis standard(s), which are added to the final extract and function as traditional internal standards, exclusively applied to the pre-extraction standards. Pre-extraction standard recoveries determined during the analysis of samples must demonstrate on a per sample basis that recovery of the labeled standard is between 20 to 130% for PCDD/PCDF and PAH (Tables OTM49-7 and OTM49-8 of this method) and between 20 to 145% for PCB (Table OTM49-9 of this method). Recoveries below the acceptable range for pre-extraction standards are an indication that sample preparation procedures did not adequately address sample or sample matrix processing to recover native target compounds. Compounds that fail this criterion should be flagged and reported as not quantitative because of QC failure. If this failure involves target compounds that are critical to the test objectives, this is a failure that requires root cause investigation and may require a repeat field sampling effort.

9.2.7.3 Pre-analysis Standard Peak Areas. The analyst must monitor the peak areas of the pre-analysis standard in all injections of the Analysis Batch. Response of all pre-analysis standard compounds must show a S/N for every selected ion current profile of ≥ 5 . Poor sensitivity compared to initial calibration response may indicate injection errors or instrument drift.

The pre-analysis standard (as indicated by peak area) in any chromatographic run must be 50 to 150% of the average area measured during the initial calibration. Random evaporation losses have been observed with the use of polypropylene caps causing high-biased pre-analysis standard areas. If a pre-analysis standard peak area for a single sample in an analysis batch does not meet these criteria, reanalyze the extract in a subsequent analysis batch. If the pre-analysis standard peak area fails to meet the acceptance criteria in the repeat analysis, or if multiple samples in a batch fail to meet the pre-analysis standard peak area criteria, perform corrective action and reanalyze the failed samples.

9.3 Compound Identification.

9.3.1 PCDD/PCDF and PCB.

9.3.1.1 The signals for the transition ions in Tables OTM49-4 and OTM49-6, for PCDD/PCDF and PCB, respectively, must be present.

9.3.1.2 Target compounds must have transition ion ratios within the control limits in Table OTM49-15 of this method. When the transition ion ratio for a target analyte is outside the performance criteria, report the results as EMPC (see Section 3.7 of this method).

9.3.1.3 Report analysis results that meet the identification criteria except the abundance ratio criteria as an EMPC.

9.3.1.4 The retention time (RT) for the analytes must be within 3 seconds of the corresponding labeled pre-extraction standard. Check the RT of the quantitation ion for each analyte analyzed during an Analysis Batch. If an analyte peak drifts out of the assigned RT window, then data for that analyte is invalid for that sample. In addition, all peaks representing multiple isomers of an analyte must elute entirely within the same MRM window.

9.3.1.5 For the identification of specific PCB isomers, the retention time of the native congener must be within 0.006 Relative Retention Time (RRT) units of the labeled pre-extraction standard RRT.

9.3.1.6 The chromatographic overlap of 2,3,4,7,8-PeCDF, 2,3,4,6,7,8-HxCDF, and 1,2,3,7,8,9-HxCDF peaks with interference peaks must not exceed 25%.

9.3.1.7 Identify and quantify isomers that do not have corresponding labeled pre-extraction standards by comparing to the pre-extraction labeled standard of the same compound class with the nearest RT to the target compound.

9.3.1.8 If chromatographic peaks are detected at the RT of any PCDD/PCDF while monitoring for PCDPE, there is evidence of interference and positive bias. Data must be flagged to indicate an interference. You may report the total with bias for the affected target. To reduce the bias, you may use a confirmatory column or perform additional clean up on an archived sample followed by reanalysis. This method recommends alumina (see Section 11.3.2.4 of this method) and Florisil® (see Section 11.3.1 of this method) packing materials for removal of PCDPE during sample cleanup.

9.3.1.9 For qualitative identification, the S/N ratio for the GC signal present in every selected ion current profile for native compound response must be greater than or equal to 2.5. The transition ion ratios must be within the control limits in Table OTM49-15 of this method for the compound class measured.

9.3.1.10 The confirmation of 2,3,7,8-TeCDD and 2,3,7,8-TeCDF must satisfy the separation criteria in Section 9.2.3.1 of this method and the identification criteria specific to PCDD and PCDF in Sections 9.3.1.1 through 9.3.1.9 of this method.

9.3.2 PAH.

9.3.2.1 The signals for the transition ions in Table OTM49-5 of this method must be present.

9.3.2.2 The RRT between each native and labeled compound must be within 0.006 RRT units. The RT of the quantitation ion for each target analyte are checked in the CCCs analyzed during an Analysis Batch. If a target analyte peak drifts out of the assigned RT window, then data for that analyte is invalid in all injections acquired since the last valid CCC. In addition, all peaks representing multiple isomers of an analyte must elute entirely within the same MRM window.

9.4 Record and Report Requirements.

Record and report data and any information that will allow an independent reviewer to validate the determination of each target compound concentration. At a minimum, record and report the data as described in Sections 9.4.1 through 9.4.8 of this method.

9.4.1 Sample numbers and other sample identifiers. Each sample must have a unique identifier.

9.4.2 Field sample volume.

9.4.3 Field sampling date.

9.4.4 Custody transfer information.

9.4.5 Extraction dates.

9.4.6 Analysis dates and times.

9.4.7 Analysis sequence/run chronology.

9.4.8 Quantitation Reports.

9.4.8.1 Report analysis results that meet the identification criteria except the abundance ratio criteria as an EMPC. This method does not consider EMPC flagged data to be zero concentrations.

9.4.8.2 You must report your sample MDLs, LMB, and FTPB with analysis results.

9.4.8.3 You must report QC results in comparison to performance criteria requirements (See Table OTM49-19 of this method).

9.5 Requirements for Equivalency. The Administrator considers any modification of this method, beyond those expressly permitted in this method as options, to be a major modification subject to application and approval of alternative test procedures following EPA Guidance Document 22 currently found at: <https://www.epa.gov/emc/emc-guideline-documents>.

9.5.1 Records. As part of the laboratory's quality system, the laboratory must maintain records of modification to this method.

9.6 Method Modification QC Requirements. The analyst is permitted to modify the chromatographic and MS/MS conditions. Examples of permissible method modifications include alternate GC columns, MRM transitions, and additional QC analytes proposed for use with the method. Any method modifications must be within the scope of the established method flexibility and must retain the basic chromatographic elements of this method. The following are required after a method modification.

9.6.1 The IDC must be repeated if changes are made to analytical parameters not previously validated during the IDC. Changes that warrant a repeat of the IDC may include, for example, changing the sample volume, selecting alternate quantitation ions, extending the calibration range, adding additional pre-analysis standards, or adding additional pre-extraction standards. Each time a modification is made to this method, repeat the initial demonstration of

capability in Section 9.2.2. If the detection limit of the method will be affected by the change, the laboratory is required to demonstrate that the MDL is lower than one-third the regulatory compliance level or one-third the QRL in this method, whichever is higher. If calibration will be affected by the change, the analyst must recalibrate the instrument per Section 10.5.

9.6.2 Document Performance in Representative Sample Matrices. The analyst is required to evaluate and document method performance for the modifications in an archived field sample treated as a LFMB and LFMB duplicate.

10.0 Calibration and Standardization

10.1 Sampling System Calibration and Standardization. Same as Sections 6.1 and 10.1 through 10.7 of Method 5 of Appendix A-3 to 40 CFR Part 60.

10.2 Chromatographic Conditions. Once the initial GC-MS/MS system is tuned and operating to meet manufacturer's specification for the calibrant optimize chromatographic separation, determine the mass resolution and calibrate the mass scale as described in this section. Establish the GC operating conditions necessary to optimize retention time, resolution and peak shape and meet compound separation in Section 9.2.3. Once optimized, the same GC conditions must be used for the analysis of all standards, blanks, QC and field samples. Suggested GC operating conditions are in Table OTM49-16 of this method.

10.3 MS/MS Operating Conditions.

10.3.1 Mass Calibration and Tuning. Tune the GC-MS/MS system to meet the manufacturer's specification using a calibrant such as PFTBA. A single MRM transition characteristic of this reference compound is selected, and the intensity of its product ion is monitored throughout the analytical run and should not exceed 10% intensity or impact detector

gain/voltage settings. Check the instrument mass resolution to ensure that it is between 1.0 and 0.75 amu.

10.3.1.1 Tune Check. At the beginning and end of each Analysis Batch and at a minimum of every 12 hours, verify that the mass resolution and mass accuracy still meet the criteria in Section 10.3.1. If the criteria are not met, the instrument must be recalibrated and any samples analyzed since the last successful check must be re-analyzed.

10.3.2 Mass Spectrometer (MS/MS) resolution. Monitor the two MRM transitions specified for each target compound by injecting a standard of the compound as a single component or as part of a mixture in which there is no interference between closely eluted components. The signal from each quadrupole is scanned every 12 hours to ensure that the masses of the monitored MRM transitions remain within the expected 1 amu window. Check the instrument mass resolution to ensure that it generates at least unit resolution. The mass resolution is optimized when the precursor and product ion peaks are centered within a nominal window of ± 0.3 amu of their exact nominal mass.

10.3.3 Operating Conditions for MS/MS. Establish the MS/MS operating conditions necessary to optimize the MRM transitions and mass resolution to meet the performance requirements in Section 9. Vary the MS parameters (source voltages, source temperatures, gas flows, etc.) until optimal analyte responses are determined. The analytes may have different optimal parameters, requiring some compromise on the final operating conditions.

MS/MS parameters are optimized for the precursor and product depending on the target class being analyzed. Tables OTM49-4, OTM49-5, and OTM49-6 of this method summarize the various ion transitions (precursor to product ions) to be monitored for PCDD/PCDF, PAH, and PCB, respectively. Product ions other than those listed may be selected; however, the analyst

should avoid using ions with lower mass or common ions that may not provide enough discrimination between the analytes of interest and co-eluting interferences.

MRM analysis is required to achieve specificity for target compound analysis. Quantitative analysis is performed in the MRM mode by monitoring two MRM transitions for each analyte and labeled standard. In all cases, two masses from the molecular ion cluster are used as the precursors for chlorinated targets and one mass is used for PAH targets. The MRM transitions monitored for each analyte and labeled standard are given in Tables OTM49-4, OTM49-5, and OTM49-6.

Note: PCDPE may give a response in the MRM transitions monitored for PCDF. Therefore, MRM transitions specific to the PCDPE compounds must be monitored throughout the analytical run. Some PCB congeners give a very small response in the MRM transitions monitored for PCDD/PCDF. If there are high concentrations of PCB in the extract they may interfere with the quantification of PCDD/PCDF. See Table OTM49-6 for details of PCB MRM transitions that could be monitored in each function if there is concern that significant concentrations of PCB could be present.

10.4 GC-MS/MS Retention Times. Inject a mid- to high-level calibration standard under optimized GC-MS/MS conditions to obtain the retention times of each method analyte. Divide the analysis into segments that contain one or more chromatographic peaks. For maximum sensitivity, minimize the number of MRM transitions that are simultaneously monitored within each segment.

10.5 Initial Calibration (ICAL). Quantitative analysis is performed in the MRM mode by monitoring MRM transitions for each target analyte and labeled standard. For chlorinated target compounds, two masses from the molecular ion cluster are used as the precursors and two

masses are used for the products. The MRM transitions are monitored for each target analyte and labeled standard, given in Tables OTM49-4, OTM49-5, OTM49-6. The conditions used for the MRM transitions must be identical for each target compound and the corresponding isotopically labeled analog. The acceptance criteria for an initial calibration are in Section 9.2.4.

Note: In this method pre-analysis standards are used as reference compounds for the internal standard quantitation of the pre-extraction standards.

10.5.1 Calibration Standards. Prepare a set of at least five calibration standards as described in Section 7.4.11. The analyte concentrations in the lowest calibration standard (and low level CCC) must not be less than three times the MDL. Suggested calibration standard concentrations for native target compounds and pre-extraction labeled compounds are shown in Tables OTM49-11, OTM49-12, and OTM49-13.

10.5.2 Calibration of Target Analytes. Calibration of the target analytes by isotope dilution is based on the ratio of the peak area of the native analyte to that of the pre-extraction standard. Tables OTM49-7, OTM49-8, and OTM49-9 show the pre-extraction compounds, for applicable target compounds. Table OTM49-17 shows the assigned pre-extraction standard for applicable PCB target compounds. Calculate the calibration RRF for each target analyte (Equation OTM49-1) and fit the resulting RRF against the calibration standard concentrations with either a linear or quadratic regression.

10.5.3 For target compounds without assigned pre-extraction standards, the concentrations are determined using response factors from calibration of the compound at the same level of chlorination in the same compound class.

10.6 Calibration Range Flexibility. Tables OTM49-11, OTM49-12, and/or OTM49-13 of this method show example calibration ranges, as applicable to the compound classes analyzed.

The actual ICAL concentration used will depend upon the quantitation limit requirements of the program.

11.0 Analysis Procedure

11.1 Sample Extraction and Concentration. The sample extraction procedures in this method are the same for PCDD, PCDF, PCB and PAH targets. Figure OTM49-4 provides a flow chart showing sample container combination, extraction steps, and labeled standard spiking. Do not allow samples and extracts destined for PAH or PCB analysis to concentrate to dryness because the lower molecular weight PAH and the mono- through tri-chlorobiphenyls may be totally or partially lost.

Note: Rotary evaporation is applicable when analyzing for PCDD/PCDF only. Snyder column apparatus is recommended when analyzing for PAH and PCB.

11.1.1 Optional Soxhlet Precleaning. Place an extraction thimble (see Section 6.3.3.3 of this method) and a plug of glass wool into the Soxhlet apparatus equipped with a Dean-Stark trap, charge the apparatus with toluene, and reflux for a minimum of 3 hours. Remove the toluene and discard it. Remove the extraction thimble from the extraction system and place it in a glass beaker to catch the solvent rinses from sample transfer to the extraction thimble. Retain the clean glass wool plug. Alternatively, confirm that the LMB with associated reagents, materials, and media meets the performance requirements in Section 9.2.6.3 of this method.

11.1.2 Container No. 1 (Filter) Preparation. Spike the filter with the appropriate pre-extraction filter recovery standard to result in the final sample extract concentrations shown in Tables OTM49-7, OTM49-8, and OTM49-9 of this method taking care that all spike liquid is distributed on the filter. Allow the filter to air dry enough to prevent overspill, then transfer the filter and the contents of Container No. 1 directly to the glass extraction thimble in the glass

solvent rinse catch beaker so that the filter will be completely immersed in the solvent during extraction.

11.1.3 Adsorbent Module. Spike the adsorbent with the appropriate pre-extraction standard to result in the final sample extract concentrations shown in Tables OTM49-7, OTM49-8, and OTM49-9 of this method, as applicable. The standard is spiked into the adsorbent, not on top of the adsorbent. Transfer the adsorbent material to the glass extraction thimble in the glass solvent rinse catch beaker. Rinse the module into the thimble in the beaker with the contents of Container No. 1. Alternatively, suspend the adsorbent module directly over the extraction thimble in a beaker, then, using a wash bottle containing methanol, flush the XAD-2 into the thimble onto the filter. Thoroughly rinse the interior of the glass module that contained the XAD-2 with toluene.

11.1.4 Container No. 2 (Acetone and Toluene Rinses). Concentrate the sample to a volume of no less than 5 mL. Concentrate samples containing toluene using a heating mantle and three-ball Snyder column or a rotary evaporator as appropriate. Rinse sample Container No. 2 three times with small portions of toluene and add these to the concentrated solution and concentrate further to no less than 5 mL. This residue contains particulate matter removed in the rinse of the train probe and nozzle. Rinse the concentrated material from Container No. 2 into the glass extraction thimble containing the filter and the XAD-2 resin.

11.1.5 Transfer the solvent contained in the glass solvent rinse catch beaker to the extraction apparatus solvent reservoir. Rinse the beaker into the Soxhlet extraction apparatus solvent reservoir three times with small portions of toluene.

11.1.6 Container No. 3 (Impinger Water and Rinses). For PAH and PCB analysis, transfer the contents of Container No. 3 to a separatory funnel. Adjust to pH 2 with 6 N sulfuric

acid, if necessary. Rinse the sample container with three successive 10-mL aliquots of the toluene and add these rinses to the separatory funnel. Extract the sample by vigorously shaking the separatory funnel for 5 minutes. After complete separation of the phases, remove the solvent and filter it through a bed of precleaned, dry sodium sulfate into the Soxhlet extraction apparatus solvent reservoir. Repeat the extraction step two additional times. Adjust the pH to 11 with 6 N sodium hydroxide, re-extract the impinger water and rinses using 3 successive 10-mL aliquots of toluene, and filter it through a bed of precleaned, dry sodium sulfate into the Soxhlet extraction apparatus solvent reservoir. Rinse the sodium sulfate into the extraction apparatus solvent reservoir with toluene and discard the sodium sulfate.

11.1.7 Cover the contents of the extraction thimble with the cleaned glass wool plug to prevent the XAD-2 resin from splashing into the solvent reservoir of the extractor. Place the extraction thimble into the Soxhlet extraction apparatus.

11.1.8 Pour additional toluene to fill the solvent reservoir approximately two-thirds capacity. Add PTFE boiling chips and assemble the apparatus.

11.1.9 Adjust the heat source to cause the extractor to cycle approximately three times per hour. Extract the sample for sufficient time to meet the pre-extraction standard recovery performance criteria in Section 9 of this method. The solvent should cycle completely through the system a minimum of 48 times.

11.2 Sample Aliquots for Cleanup and Analysis.

11.2.1 After extraction, allow the Soxhlet apparatus to cool.

11.2.2 Initial Extract Concentration. You may perform an initial concentration of the sample extract using the techniques (e.g., Kuderna Danish, rotary evaporation, nitrogen blowdown) found to recover pre-extraction standard sufficient to meet the performance criteria

in Section 9 of this method. Concentrate initial extracts in toluene using a heating mantle and three-ball Snyder column or a rotary evaporator. Concentrate the FTPB and LMB samples in the same manner as samples.

Note: To meet isotopically labeled standard recoveries for low molecular weight PAH and PCB, do not evaporate samples to dryness and do not use a rotary evaporator to concentrate extracts.

11.2.3 Allow the sample to cool. You should use a minimum of one half of the sample extract for PCDD/PCDF analysis. You may archive the remaining sample aliquot or further split the extract for PCB and/or PAH analysis, and archive.

Note: If using amount other than half the sample extract, adjust the spiking amount of the labeled standards accordingly.

11.2.4 If necessary, further concentrate the sample for cleanup and analysis using concentration techniques (e.g., Kuderna Danish, rotary evaporation, nitrogen blowdown) found to recover pre-extraction standard sufficient to meet the performance criteria in Section 9 of this method.

11.3 Sample Cleanup and Fractionation. You may process a separate aliquot/split of the sample extract for each of the compound classes analyzed by this method. Sample cleanup for each compound class may include techniques in addition to column chromatography such as acid/base back-extraction, Gel Permeation Chromatography or high-performance liquid chromatography (HPLC) to isolate target compounds from interferences. The sample cleanup and fractionation in this section are shown to meet the performance criteria in Sections 9.2.7 and 9.3 of this method and are recommended but not required. You may modify cleanup column dimensions to meet manual or automated cleanup procedures as technology changes and

improves. You must evaluate the cleanup and fractionation procedures used to confirm acceptable recovery of isotopically labeled standards. The alternative procedures must provide sufficient cleanup to meet method identification criteria (Section 9.3 of this method) and recovery criteria (Section 9.2.7 of this method).

Note: Recommendations in this section provide a cleanup approach that may allow multiple compound class measurement from a single aliquot of the original sample extract. Typically, Florisil® and alumina are used to separate PAH and PCDPE from PCDD and PCDF target compounds. Use acid, neutral, and basic silica gel and cleanup procedures to remove nonpolar and polar interferences from samples destined for PCB and PCDD/PCDF analysis. Use Carbpac®/Celite® (or other equivalent carbon-based column material) to remove other nonpolar interferences.

11.3.1 PAH and PCDPE Fractionation and Cleanup. You may use a Florisil® column to remove PAH and PCDPE from a sample extract. You may also fractionate sample extracts using Florisil® as the first cleanup step to separate PAH for analysis.

Note: High concentrations of PAH may interfere, leading to failure of performance criteria for PCDD/PCDF or PCB analysis.

11.3.1.1 Pack a 6-mm ID chromatographic column or equivalent diameter glass pipet with a glass wool plug followed by approximately 1.5 g (approximately 2 mL) of activated Florisil®. Add approximately 1 cm (approximately 1 mL) of anhydrous sodium sulfate followed by a glass wool plug to the head of the column. Pre-elute the column with 10 mL of methylene chloride followed by 10 mL of hexane and discard the eluate.

11.3.1.2 When the solvent is within 1 mm of the packing, transfer the concentrated extract (up to 5 mL) to the top of the Florisil® column, rinse the sample container twice with 1 to

2 mL of hexane, adding each rinse to the column, and elute the column with 35 mL of 5% dichloromethane in hexane. This fraction (Fraction 1) should contain target PCB, and selected hydrocarbons and chlorinated monoaromatic compounds.

11.3.1.3 Elute the column with 35 mL of 15% of dichloromethane in hexane and collect the eluate. This fraction (Fraction 2) should contain target PCDD/PCDF compounds.

11.3.1.4 Elute the column with 50 mL of 50% dichloromethane in hexane. The fraction (Fraction 3) should contain target PAH.

11.3.1.5 If necessary to remove any remaining polar organic compounds, elute the column with 70 mL of 15% acetone in hexane.

11.3.2 PCDD/PCDF and PCB Fractionation and Cleanup. You may remove PAH from the original aliquot of sample extract used for PCDD/PCDF analysis as described in Section 11.3.1 of this method. Design the column cleanup chromatography for PCDD/PCDF and PCB such that two consecutive fractions are collected (one with PCDD/PCDF and one with PCB) without impacting the detection limits. Depending on the source and sample matrix of the original sample, one or more of the following column cleanup approaches may be necessary to further remove polyhalogenated diphenyl ethers. You may use any number of permutations found in the referenced literature for this cleanup if the pre-extraction standard recoveries from field and LMB samples meet the associated performance criteria in Section 9 of this method. Alternatively, you may use an automated cleanup approach that meets the labeled standard recovery requirements in Section 9 of this method.

11.3.2.1 Silica Gel Column Chromatography. Pack one end of a glass column, approximately 20 mm ID x 230 mm long, with glass wool. Add in sequence to the glass column, 1 g of silica gel, 2 g of sodium hydroxide impregnated silica gel, 1 g of silica gel, 4 g of acid-

modified silica gel, 1 g of silica gel, and 1 cm layer of anhydrous sodium sulfate. Pre-elute the column with 30 to 50 mL of hexane leaving a small quantity of hexane above the sodium sulfate layer. Discard the pre-elution hexane. Add the sample extract, dissolved in 5 mL of hexane to the head of the column. Allow the sample to flow into the column leaving a small quantity of hexane above the sodium sulfate layer. Rinse the extract container with two additional 5-mL rinses of hexane and apply each rinse to the column separately as the previous addition elutes. Elute the column with an additional 90 mL of hexane and retain the entire eluate. Concentrate this solution to a volume of about 1 mL using the nitrogen evaporative concentrator (see Section 6.3.5 of this method).

11.3.2.2 Silver Nitrate Silica Gel Column Chromatography. Pack a column (6 mm ID, 150 mm in length) sequentially with 1 g of silica gel and 1 g of 10% silver nitrate silica gel followed by a layer of about 10 mm of sodium sulfate (anhydrous). Wash the column sufficiently with hexane, elute until the liquid level reaches to the upper end of the column, and then transfer the concentrated sample (about 5 mL). Wash the container several times with a small amount of hexane, elute with 200 mL of hexane at a flow rate about 2.5 mL/min (approximately one drop per second) to elute PCDD/PCDF.

11.3.2.3 Multi-layer Silica Gel Column Chromatography. You may use a multi-layer silica gel column in place of separate silica columns. Pack a column of 20 mm ID and 300 mm in length sequentially by the dry pack method with 0.9 g of silica gel, 3.0 g of 2% potassium hydroxide silica gel, 0.9 g of silica gel, 4.5 g of 44% sulfuric acid silica gel, 6.0 g of 22% sulfuric acid silica gel, 0.9 g of silica gel, 3.0 g of 10% silver nitrate silica gel, 2.0 g of silica gel and 6.0 g of sodium sulfate (anhydrous). Wash the column sufficiently with hexane, elute until the liquid level reaches to the upper end of the column, and then load the sample solution. Rinse the

container several times with a small amount of hexane, elute with 150-200 mL of hexane at a flow rate about 2.5 mL/min (approximately one drop per second) to elute PCDD/PCDF.

11.3.2.4 Basic Alumina Column Chromatography. Pack a column (20 mm ID, 300 mm in length) with approximately 6 to 12 g of basic alumina. Pre-elute the column with 50 to 100 mL of hexane. Transfer the concentrated extract from the previous column cleanup to the top of the basic alumina column. Allow the sample to flow into the column leaving a small quantity of solvent above the top of the bed. Rinse the extract container with two additional 1-mL rinses of hexane and apply each rinse to the column separately as the previous addition elutes. Elute the column with 100 mL hexane to remove the interferences. Elute the PCDD/PCDF from the column with 20 to 40 mL of 50% methylene chloride in hexane. The ratio of methylene chloride to hexane may vary depending on the activity of the alumina used in the column preparation. Do not let the head of the column go without solvent. The first 100 mL hexane eluate is not used for subsequent PCDD/PCDF analysis. The eluate is concentrated to approximately 0.5 mL using the nitrogen evaporative concentrator.

11.3.2.5 Carbopack® C/Celite® 545 Column or Equivalent. Cut both ends from a 10 mL disposable Pasteur pipette (see Section 6.4.1 of this method) to produce a 10 cm column. Fire-polish both ends and flare both ends if desired. Insert a glass wool plug at one end and pack the column with 0.55 g of Carbopack®/Celite® (see Section 7.4.9 of this method) to form an adsorbent bed approximately 2 cm long. Insert a glass wool plug on top of the bed to hold the adsorbent in place. Pre-elute the column with 5 mL of toluene followed by 2 mL of methylene chloride:methanol:toluene (15:4:1 volume/volume (v/v)), 1 mL of methylene chloride:cyclohexane (1:1 v/v), and 5 mL of hexane. If the flow rate of eluate exceeds 0.5 mL/minute, discard the column. Do not let the head of the column go without solvent. Add the

sample extract to the column. Rinse the sample container twice with 1 mL portions of hexane and apply separately to the column. Apply 2 mL of hexane to the head of the column to complete the transfer. Elute the interfering compounds with two 3 mL portions of hexane, 2 mL of methylene chloride:cyclohexane (1:1 v/v), and 2 mL of methylene chloride:methanol:toluene (15:4:1 v/v). Discard the eluate. Invert the column and elute the PCDD/PCDF with 20 mL of toluene. If carbon particles are present in the eluate, filter through glass-fiber filter paper. Concentrate the eluate to approximately 0.5 mL using the nitrogen evaporative concentrator for further cleanup or analysis by GC-MS/MS.

11.4 PCDD, PCDF, PCB and PAH Sample Analysis.

11.4.1 Analyze the sample extract with an GC-MS/MS using the instrumental parameters in Sections 11.4.2 and 11.4.3 of this method.

11.4.1.1 Immediately prior to analysis, add an aliquot (typically 20 microliters (μl)) of the pre-analysis standard to result in the final sample concentrations in Tables OTM49-7, OTM49-8, and OTM49-9 of this method to each sample as appropriate for the target compounds.

11.4.1.2 Inject an aliquot of the sample extract into the GC, typically 1 μl . You may perform separate analyses using different GC columns for each of the target compound classes. Perform calibration and sample analysis for each target compound class using the same instrument operating conditions including injection volume.

11.4.1.2.1 If target compounds are not resolved sufficiently from other target compounds or interferences in the sample to meet the requirements in Section 9.2.3 of this method, as applicable to the target compound class, or as otherwise specified in an applicable regulation, permit, or other requirement, analyze sample (or another aliquot of the sample) using an

alternative column that provides elution order to uniquely quantify the target compounds subject to interference on the first GC column.

11.4.1.2.2 You may use column systems other than those recommended in this method provided the analyst is able to demonstrate, using calibration and CCCs, that the alternative column system is able to meet the applicable specifications of Section 9.2.3 of this method.

11.4.2 If establishing an initial calibration for the first time, complete the IDC prior to analyzing field samples. Analyze field and QC samples in a properly sequenced Analysis Batch as described in Section 11.5.

11.4.3 Verify Retention Time Windows. The analyst must ensure that each target analyte elutes entirely within the assigned window during each Analysis Batch. Make this observation by viewing the quantitation ion for each analyte in the CCCs analyzed during an Analysis Batch. The RTs must meet the criteria in Sections 9.3.1.4 and 9.3.2.2 of this method, as applicable for the target compounds.

11.5 GC-MS/MS conditions for the Analysis Batch must be the same as those used during calibration.

11.5.1 Analyze Initial CCC. After a valid calibration is established, begin every Analysis Batch by analyzing an initial low-level CCC, at no more than three times the QRL. The initial CCC confirms that the calibration is still valid. Failure to meet the QC criteria may indicate that recalibration is required prior to analyzing samples.

11.5.2 Analyze Field and QC Samples. After the initial CCC, continue the Analysis Batch by analyzing an LMB, followed by the field samples and QC samples. Analyze a mid- or high-level CCC after every ten field samples and at the end of each Analysis Batch. Do not count QC samples (LMB, LFMB, LFMB duplicate) when calculating the required frequency of CCCs.

11.5.3 Analyze Final CCC. The last injection of the Analysis Batch must be a mid- or high-level CCC. The acquisition start time of the final CCC must be within 12 hours of the acquisition start time of the low-level CCC at the beginning of the Analysis Batch. More than one Analysis Batch within a 24-hour period is permitted. An Analysis Batch may contain field and QC samples from multiple extraction batches.

11.5.4 Initial Calibration Frequency. A full calibration curve is not required before starting a new Analysis Batch. A previous calibration can be confirmed by running an initial, low-level CCC followed by an LMB. If a new calibration curve is analyzed, an Analysis Batch run immediately thereafter must begin with a low-level CCC and an LMB.

11.6 Quantitation. Measure the response of each native target compound and the corresponding pre-extraction standard using the quantitation product ions. Using the final CCC RRF, calculate the mass of the target compound, using equations in Section 12.7 of this method. Use the pre-extraction standard to correct the native target compounds result for variations in performance of the extraction, cleanup, and concentration steps of the analysis. Recovery of pre-extraction standard must meet minimum specifications (in Section 9.2.7.2 of this method) to ensure that the method performance and reliability have not been compromised by unacceptable losses during sample processing. Table OTM49-17 of this method shows the assignments for pre-extraction standard compounds for use in calculating the response factor and the concentrations of PCB. Recoveries of all labeled standard compounds must meet the minimum recovery specifications in Tables OTM49-7, OTM49-8, and/or OTM49-9 of this method.

Note: Unacceptably low recoveries can be an indication of a sample processing step that caused the low recoveries, such as spiking errors.

11.6.1 Use Equation OTM49-7 to calculate the amount of each target compound or group in the sample.

11.6.2 Use Equation OTM49-8 to calculate the concentration per dscm of each target compound or group in the gas.

11.6.3 Quantify native PCDD and PCDF in its homologous series using the corresponding native and pre-extraction standard response in its homologous series. For example, use $^{13}\text{C}_{12-2,3,7,8}\text{-TeCDD}$ to calculate the concentrations of all other tetra chlorinated isomers.

11.6.4 As an option or as required or specified in applicable regulations, permits, or other requirements, you may quantify any or all other PCB congeners as resolved or coeluting combinations using the RRF of the nearest eluting native target PCB in the same homolog group and the pre-extraction standard assigned in Appendix A to this method.

11.6.5 As an option or as required or specified in applicable regulations, permits, or other requirements, report the total concentration of congeners at a given level of chlorination (homolog; i.e., total TrCB, total PeCB, total HxCB, etc.) by summing the concentrations of all congeners identified in the retention time window for the homologs as assigned in Appendix A to this method.

11.6.6 As an option or if required in an applicable regulation, permit or other requirement, total PCB may be reported by summing all congeners identified at all window-defined congeners (WDCs) as assigned in Appendix A to this method.

12.0 Data Analysis and Calculations

Note: Same as Section 12 of Method 5 of Appendix A-3 to 40 CFR Part 60, with the following additions.

12.1 Nomenclature.

A_{1n} = Integrated area of the primary product ion for the target native compound.

A_{1pe} = Integrated area of the primary product ion for the pre-extraction standard compound (assigned in Tables OTM49-4, OTM49-5, and OTM49-6 of this method).

A_{1pa} = Integrated area of the primary product ion for the pre-analysis standard compound.

A_{2n} = Integrated area of the secondary product ion for the target native compound. For PAH $A_{2n} = 0$.

A_{2pe} = Integrated area of the secondary product ion for the pre-extraction standard compound.

For PAH $A_{2i} = 0$.

A_{2pa} = Integrated area of the secondary product ion for the pre-analysis standard compound.

C_i = Mass of compound i in the sample, pg.

C_{idscm} = Concentration of target native compound i in the emission gas, pg/dscm.

C_T = Total mass of target compounds in the sample, pg/sample.

dscm = Dry standard cubic meters of gas volume sample measured by the dry gas meter, corrected to standard conditions.

L_{PIR} = Lower limit for the prediction interval of results.

n = Number of values.

PD = Percent Difference in the RRF of the CCC compared to the average RRF of the initial calibration, %.

Q_n = Quantity of the target native compound, pg.

Q_{pe} = Quantity of the pre-extraction standard, pg.

Q_{pa} = Quantity of the pre-analysis standard, pg.

R = Recovery of pre-sampling adsorbent standard and pre-extraction filter recovery standard, %.

R_{pe} = Recovery of pre-extraction standard, %.

RRF_i = Relative response factor of a native target compound or pre-sampling adsorbent standard and pre-extraction filter recovery standard at calibration level i .

RRF_{pe} = Relative response factor of a pre-extraction standard compound.

RRF_{ccc} = Relative response factor of a target compound in the CCC or pre-sampling adsorbent standard and pre-extraction filter recovery standard in the CCC.

RSD = Relative standard deviation, in this case, of RRFs over the calibration levels, %.

SD_{RRF} = Standard deviation of initial calibration RRFs.

SD_s = Standard deviation of multiple (at least 7) low level standards.

SDL = Stack detection limit.

$T_{(n-1,1-\alpha=0.99)}$ = Student's T value at 99% confidence interval for $n-1$ degrees of freedom.

U_{PIR} = Upper limit for the predictions interval of results.

WDC = Window-defined congener representing an isotopically labeled compound that defines the beginning or end of a retention time window bracketing a target homolog.

12.2 Individual Compound RRF for Each Calibration Level i . Equation OTM49-1 for the response factor of each target native compound relative to its labeled pre-extraction spike analog includes the integrated areas of both the primary and secondary MRM transition product ions for each compound in the calibration standard. PAH RRF are determined using the primary product ion. Use Equation OTM49-2 to calculate the RRF for the pre-extraction standard.

$$RRF_i = \frac{(A_{1n} + A_{2n})Q_{pe}}{(A_{1pe} + A_{2pe})Q_n} \quad \text{Eq. OTM49-1}$$

$$RRF_{pe} = \frac{(A_{1pe} + A_{2pe})Q_{pa}}{(A_{1pa} + A_{2pa})Q_{pe}} \quad \text{Eq. OTM49-2}$$

Note: the units for Q_{pe} and Q_n in Eq. 23-1 and the units for Q_{pa} and Q_{pe} in Eq. OTM49-2 must be the same.

12.3 Average RRF for Each Compound Over the Calibration Levels.

$$\overline{RRF} = \frac{1}{n} \sum_{i=1}^n RRF_i \quad \text{Eq. OTM49-3}$$

12.4 Percent RSD of the RRFs for a Compound Over the Calibration Levels. The requirement for the initial calibration RSD is in Section 9.2.4 and Table OTM49-14 of this method.

$$RSD = \frac{SD_{RRF}}{\overline{RRF}} \times 100\% \quad \text{Eq. OTM49-4}$$

12.5 Standard Deviation of the RRFs for a Compound Over the Calibration Levels.

$$SD_{RRF} = \sqrt{\frac{\sum_{i=1}^n (x_i - \bar{x})^2}{n-1}} \quad \text{Eq. OTM49-5}$$

12.6 Percent Difference of the RRF of the Continuing Calibration Check Compared to the Average RRF from the Initial Calibration for Each Target Compound. Use Equation OTM49-1 to calculate the RRF for the CCC for comparison to the average RRF from the initial calibration. The requirement for the CCC percent difference is in Section 9.2.5 and Table OTM49-14 of this method.

$$PD = \frac{RRF_{CCC} - \overline{RRF}}{\overline{RRF}} \times 100\% \quad \text{Eq. OTM49-6}$$

12.7 Amount of Individual Target Compound i in the Sample by Isotope Dilution (pg).

This equation corrects for the target native compound recovery based on its labeled pre-extraction standard analog. This equation is also used to calculate the amount of pre-sampling adsorbent standard and pre-extraction filter recovery standard recovered.

$$C_i = \left[\frac{Q_{pe} (A_{1n} + A_{2n})}{(A_{1pe} + A_{2pe}) RRF_{CCC}} \right] \quad \text{Eq. OTM49-7}$$

12.8 Concentration of the Individual Target Compound or Group *i* in the Emission Gas (pg/dscm). The total concentration of a target compound group in the sample can be calculated by substituting C_T from Eq. OTM49-12 for C_i in Eq OTM49-8.

$$C_{idscm} = \frac{C_i}{dscm} \quad \text{Eq. OTM49-8}$$

12.9 Recovery of Labeled Compound Standards. Use Equation OTM49-9 to determine the recovery of pre-sampling adsorbent standard and the pre-extraction filter recovery standard. Use Equation OTM49-10 to determine the recovery of the pre-extraction standard. The recovery performance criteria for these standards are in Sections 9.2.7.1 and 9.2.7.2 of this method.

$$R = \frac{\text{conc. found}}{\text{conc. spiked}} \times 100\% \quad \text{Eq. OTM49-9}$$

$$R_{pe} = \left[\frac{Q_{pa} (A1_{pe} + A2_{pe})}{(A1_{pa} + A2_{pa})(Q_{pe})(RRF_{pe})} \right] \times 100\% \quad \text{Eq. OTM49-10}$$

Note: R_{pe} must be corrected for the fraction of the original sample extract used for analysis. (e.g., if half of the extract is used for analysis of the target class, R_{pe} must be multiplied by a factor of 2).

12.10 Method Detection Limit (MDL).

$$MDL = SD_s \times T_{(n-1, 1-\alpha=0.99)} \quad \text{Eq. OTM49-11}$$

12.11 Total Target Compound Mass.

$$C_T = \frac{1}{n} \sum_{i=1}^n C_i \quad \text{Eq. OTM49-12}$$

Note: Unless otherwise specified in applicable regulations, permits or other requirements, count any target compounds reported as non-detected as MDL when calculating the concentration of target compounds in the sample.

12.12 Upper and Lower Limits for the Prediction Interval of Results (PIR)

Half Range (HR) for the Prediction Interval of Results

$$HR_{PIR} = (3.963)(SD_s) \quad \text{Eq. OTM49-13}$$

Note: 3.963 is a constant value for seven replicates.

Upper and Lower Limits for the Prediction Interval of Results

$$U_{PIR} = \left[\frac{(Mean + HR_{PIR})}{Spike\ Concentration} \right] 100\% \quad \text{Eq. OTM49-14}$$

$$L_{PIR} = \left[\frac{(Mean - HR_{PIR})}{Spike\ Concentration} \right] 100\% \quad \text{Eq. OTM49-15}$$

12.13 Stack Detection Limit (SDL). The stack detection limit for each target compound can be calculated in units of mass/sample volume.

$$SDL = \frac{MDL}{dscm} \quad \text{Eq. OTM49-16}$$

13.0 Method Performance [Reserved]

14.0 Pollution Prevention

The target compounds used as standards in this method are prepared in extremely small amounts and pose little threat to the environment when managed properly. Prepare standards in volumes consistent with laboratory use to minimize the disposal of excess volumes of expired standards.

15.0 Waste Management

15.1 The laboratory is responsible for complying with all federal, state, and local regulations governing waste management, particularly the hazardous waste identification rules and land disposal restrictions, and for protecting the air, water, and land by minimizing and controlling all releases from fume hoods and bench operations. The laboratory must also comply with any sewage discharge permits and regulations. The EPA's *Environmental Management Guide for Small Laboratories* (EPA 233-B-98-001) provides an overview of requirements.

15.2 Samples containing hydrogen chloride or sulfuric acid to pH <2 are hazardous and must be handled and disposed in accordance with federal, state, and local regulations.

15.3 For further information on waste management, consult *The Waste Management Manual for Laboratory Personnel* and *Less is Better-Laboratory Chemical Management for Waste Reduction*, available from the American Chemical Society's Department of Government Relations and Science Policy, 1155 16th Street N.W., Washington, D.C. 20036.

16.0 Bibliography

1. American Society of Mechanical Engineers. Analytical Procedures to Assay Stack Effluent Samples and Residual Combustion Products for Polychlorinated Dibenzo-p-Dioxins (PCDD) and Polychlorinated Dibenzofurans (PCDF). Prepared for the U.S. Department of Energy and U.S. Environmental Protection Agency. Washington, DC. December 1984. 23 p.

2. American Society of Mechanical Engineers. Sampling for the Determination of Chlorinated Organic Compounds in Stack Emissions. Prepared for U.S. Department of Energy and U.S. Environmental Protection Agency. Washington DC. December 1984. 25 p.

3. Fishman, V.N., Martin, G.D. and Lamparski, L.L., Comparison of a variety of gas chromatographic columns with different polarities for the separation of chlorinated dibenzo-p-dioxins and dibenzofurans by high-resolution mass spectrometry, *Journal of Chromatography A* 1139 (2007) 285-300.

4. International Agency for Research on Cancer. Environmental Carcinogens Methods of Analysis and Exposure Measurement, Volume 11 – Polychlorinated Dioxins and Dibenzofurans. IARC Scientific Publications No. 108, 1991.

5. Stieglitz, L., Zwick, G., Roth, W. Investigation of different treatment techniques for PCDD/PCDF in fly ash. *Chemosphere* 15: 1135-1140; 1986.

6. Triangle Laboratories. Case Study: Analysis of Samples for the Presence of Tetra Through Octachloro-*p*-Dibenzodioxins and Dibenzofurans. Research Triangle Park, NC. 1988. p. 26.

7. U.S. Environmental Protection Agency. Method 8290A—Polychlorinated Dibenzo-*p*-dioxins (PCDDs) and Polychlorinated Dibenzofurans (PCDFs) by High-Resolution Gas Chromatography/High-Resolution Mass Spectrometry (HRGC/HRMS), Revision 1. February 2007. In: Test Methods for Evaluating Solid Waste, Physical/Chemical Methods, EPA publication SW-846. Washington, DC.

8. U.S. Environmental Protection Agency. Office of Air Programs Publication No. APTD-0576: Maintenance, Calibration, and Operation of Isokinetic Source Sampling Equipment. Research Triangle Park, NC. March 1972.

9. U.S. Environmental Protection Agency. Method 1625C-Semivolatile Organic Compounds by Isotope Dilution GCMS. June 1989.

10. U.S. Environmental Protection Agency. Method 1613B-Tetra- through Octa-Chlorinated Dioxins and Furans by Isotope Dilution HRGC/HRMS. October 1994.

11. U.S. Environmental Protection Agency. Method 1668C-Chlorinated Biphenyl Congeners in Water, Soil, Sediment, Biosolids, and Tissue by HRGC/HRMS. April 2010.

12. Tondeur, Y., Nestrick, T., Silva, Héctor A., Vining, B., Hart, J. Analytical procedures for the determination of polychlorinated-*p*-dioxins, polychlorinated dibenzofurans, and hexachlorobenzene in pentachlorophenol. Chemosphere Volume 80, Issue 2, June 2010, pages 157-164.

13. U.S. Environmental Protection Agency. Definition and Procedure for the Determination of the Method Detection Limit, Revision 2. EPA 821-R-16-006. December 2016.

14. Tondeur Y, Niederhut WJ, Missler SR. A hybrid HRGC/MS/MS Method for the Characterization of Tetrachlorodibenzo-*p*-Dioxins in Environmental Samples; Bio. Med. and Environ. Mass Spectr. 14, pages 449-456, 1987.

15. Gianluca R., Mosca S., Guerriero E., Rotatori M. Development of a new automated clean-up system for the simultaneous analysis of polychlorinated dibenzo-*p*-dioxins (PCDDs), dibenzofurans (PCDFs) and 'dioxin-like' polychlorinated biphenyls (dl-PCB) in flue gas emissions by GPC-SPE. J. Environ. Monit. 14, pages 1082-1090, 2012.

16. U.S. Environmental Protection Agency. The National Dioxin Air Monitoring Network (NDAMN) Report of the Results of Atmospheric Measurements of Polychlorinated Dibenzo-*p*-Dioxins (PCDDs), Polychlorinated Dibenzofurans (PCDFs), and Dioxin-like Polychlorinated Biphenyl (PCBs) in Rural and Remote Areas of the United States from June 1998 through November 2004. EPA/600/R-13/183F. August 2013.

17. Guo, Y., Kannan, K. Analytical Methods for the Measurement of Legacy and Emerging Persistent Organic Pollutants in Complex Sample Matrices. Comprehensive Analytical Chemistry. Vol. 67. January 2015.

18. U.S. Environmental Protection Agency. USEPA Contract Laboratory Program (CLP) National Functional Guidelines for Chlorinated Dibenzo-*p*-Dioxins (CDDs) and Chlorinated Dibenzofurans (CDFs) Data Review. EPA-540-R-11-016. September 2011.

19. SGS AXYS Analytical Services. SGS AXYS Method 16130 Determination of 2,3,7,8-substituted Tetra- through Octa-Chlorinated Dibenzo-*p*-Dioxins and Dibenzofurans (CDDs/CDFs) Using Waters and Agilent Gas Chromatography Mass Spectrometry (GC-MS/MS) Revision 1.0.

20. Angel García-Bermejo, Manuela Abalos, Jordi Saulo, Esteban Abad, María Jose Gonzalez, Belen Gomara. A real alternative to high resolution magnetic sector instrument for the analysis of polychlorinated dibenzo-p-dioxins, furans and dioxin-like polychlorinated biphenyls. *Analytica Chimica Acta* 889. Pages 156-165. 2015.

21. Paul Silcock, David Gardner, John Fardon, Steve Moss, Inge de Dobbeleer, Thermo Scientific Bremen, Germany, NLS-Environmental Agency, Leeds, UK. Determination of PCDD/Fs in Environmental Samples using Accelerated Solvent Extraction (ASE) and GC-MS/MS. Thermo Scientific Application Note 10336.

22. Peter Furst, Thorsten Bernsmann, Dominik Baumeister, Chris Sandy, Agilent. Determination of Polychlorinated Dibenzo-p-dioxins (PCDD) and Polychlorinated Dibenzofurans (PCDF) in Foodstuffs and Animal Feed Using the Agilent 7000 Triple Quadrupole GC/MS System.

23. Huizhong Sun, Pu Wang, Honghua Li, Yingming, Li, Shucheng Zheng, Julius Matsiko, Yanfen Hao, Weiwei Zhang, Dou Wang, Qinghua Zhang. Determination of PCDD/Fs and dioxin-like PCBs in food and feed using gas chromatography-triple quadrupole mass spectrometry. *Sci China Chem.* Volume 60. Pages 670-677. 2017.

24. Inge de Dobbeleer, Joachim Gummersbach, Hans-Joachim Huebschmann, Anton Mayer, Paul Silcock. Consolidated GC-MS/MS Analysis of OCPs, PAHs, and PCBs in Environmental Samples. Application Note 52389.

25. Kim A. Anderson, Michael J. Szelewski, Glenn Wilson, Bruce D. Quimby, Peter D. Hoffman. Modified ion source triple quadrupole mass spectrometer gas chromatograph for polycyclic aromatic hydrocarbon analyses. *J Chromatogr A.* Volume 1419. Pages 89–98. November 2015.

26. Dr. Stephan Schroeder, Shimadzu Germany, Peak Scientific. Poster: GC-MS/MS analysis of PAH and PCB in environmental samples.
27. Benedetti_et_al *J Sep Sci.* 2017;**40**:3469–3478.
28. ICES TECHNIQUES IN MARINE ENVIRONMENTAL SCIENCES NO. 50 MAY 2012.
29. Inge de Dobbeleer, Joachim Gummersbach, Hans-Joachim Huebschmann, Anton Mayer, Paul Silcock, Consolidated GC-MS/MS Analysis of OCPs, PAHs, and PCBs in Environmental Samples, Thermo Fisher Scientific, Dreieich, Germany Thermo - Application Note 52389.
30. Angel García-Bermejo, Manuela _Abalos, Jordi Saulo , Esteban Abad, María Jose Gonzalez, Belen Gomara, Triple quadrupole tandem mass spectrometry: A real alternative to high resolution magnetic sector instrument for the analysis of polychlorinated dibenzo-p-dioxins, furans and dioxin-like polychlorinated biphenyls. *Analytica Chimica Acta* 889 (2015) 156e165.

Table OTM49-1. Polychlorinated Dibenzo-*p*-dioxin and Polychlorinated Dibenzofuran Target Analytes

Polychlorinated Dibenzo- <i>p</i> -dioxins	CAS ^a Registry Number	Polychlorinated Dibenzofurans	CAS ^a Registry Number
2,3,7,8-TeCDD	1746-01-6	2,3,7,8-TeCDF	51207-31-9
1,2,3,7,8-PeCDD	40321-76-4	1,2,3,7,8-PeCDF	57117-41-6
1,2,3,4,7,8-HxCDD	39227-28-6	2,3,4,7,8-PeCDF	57117-31-4
1,2,3,6,7,8-HxCDD	57653-85-7	1,2,3,4,7,8-HxCDF	70648-26-9
1,2,3,7,8,9-HxCDD	19408-74-3	1,2,3,6,7,8-HxCDF	57117-44-9
1,2,3,4,6,7,8-HpCDD	35822-46-9	1,2,3,7,8,9-HxCDF	72918-21-9
Total TeCDD	41903-57-5	2,3,4,6,7,8-HxCDF	60851-34-5
Total PeCDD	36088-22-9	1,2,3,4,6,7,8-HpCDF	67562-39-4
Total HxCDD	34465-4608	1,2,3,4,7,8,9-HpCDF	55673-89-7
Total HpCDD	37871-00-4	Total TeCDF	55722-27-5
Total OCDD	3268-87-9	Total PeCDF	30402-15-4
		Total HxCDF	55684-94-1
		Total HpCDF	38998-75-3
		Total OCDF	39001-02-0

^a Chemical Abstract Service.**Table OTM49-2. Polycyclic Aromatic Hydrocarbon Target Analytes**

Polycyclic Aromatic Hydrocarbons	CAS ^a Registry Number	Polycyclic Aromatic Hydrocarbons	CAS ^a Registry Number
Naphthalene	91-20-3	Chrysene	218-01-9
2-Methylnaphthalene	91-57-6	Benzo[<i>b</i>]fluoranthene	205-99-2
Acenaphthylene	208-96-8	Benzo[<i>k</i>]fluoranthene	207-08-9
Acenaphthene	83-32-9	Perylene	198-55-8
Fluorene	86-73-7	Benzo[<i>a</i>]pyrene	50-32-8
Anthracene	120-12-7	Benzo[<i>e</i>]pyrene	192-92-2
Phenanthrene	85-01-8	Benzo[<i>g,h,i</i>]perylene	191-24-2
Fluoranthene	206-44-0	Indeno[<i>1,2,3-cd</i>]pyrene	193-39-5
Pyrene	129-00-0	Dibenz[<i>a,h</i>]anthracene	53-70-3
Benzo[<i>a</i>]anthracene	56-55-3		

^a Chemical Abstract Service.**Table OTM49-3. Polychlorinated Biphenyl Target Analytes**

PCB Congener	BZ No. ^a	CAS ^b Registry Number	PCB Congener	BZ No. ^a	CAS ^b Registry Number
2,4'-DiCB	8	34883-43-7	2,2',3,3',4,4'-HxCB	128	38380-07-3
2,2',5-TrCB	18	37680-65-2	2,2',3,4,4',5'-HxCB	138	35065-28-2
2,4,4'-TrCB	28	7012-37-5	2,2',4,4',5,5'-HxCB	153	35065-27-1
2,2',3,5'-TeCB	44	41464-39-5	2,3,3',4,4',5-HxCB	156	38380-08-4
2,2',5,5'-TeCB	52	35693-99-3	2,3,3',4,4',5'-HxCB	157	69782-90-7

PCB Congener	BZ No. ^a	CAS ^b Registry Number	PCB Congener	BZ No. ^a	CAS ^b Registry Number
2,3',4,4'-TeCB	66	32598-10-0	2,3',4,4',5,5'-HxCB	167	52663-72-6
3,3',4,4'-TeCB	77	32598-13-3	3,3',4,4',5,5'-HxCB	169	32774-16-6
3,4,4',5-TeCB	81	70362-50-4	2,2',3,3',4,4',5-HpCB	170	35065-30-6
2,2',4,5,5'-PeCB	101	37680-73-2	2,2',3,4,4',5,5'-HpCB	180	35065-29-3
2,3,3',4,4'-PeCB	105	32598-14-4	2,2',3,4',5,5',6-HpCB	187	52663-68-0
2,3,4,4',5-PeCB	114	74472-37-0	2,3,3',4,4',5,5'-HpCB	189	39635-31-9
2,3',4,4',5-PeCB	118	31508-00-6	2,2',3,3',4,4',5,6-OcCB	195	52663-78-2
2',3,4,4',5-PeCB	123	65510-44-3	2,2',3,3',4,4',5,5',6-NoCB	206	40186-72-9
3,3',4,4',5-PeCB	126	57465-28-8	2,2',3,3',4,4',5,5',6,6'-DeCB	209	2051-24-3

^a BZ No.: Ballschmiter and Zell 1980, or International Union of Pure and Applied Chemistry (IUPAC) number.

^b Chemical Abstract Service.

Table OTM49-4. Example MRM Transitions for PCDD and PCDF²⁸

Compound	Quant. Precursor Ion m/z	Quant. Product Ion m/z	Qual. Precursor Ion m/z	Qual. Product Ion m/z
¹³ C ₁₂ -TeCDD	332	268	334	270
TeCDD	320	257	322	259
¹³ C ₁₂ -TeCDF	318	254	316	252
TeCDF	304	241	306	243
¹³ C ₁₂ -PeCDD	366	302	368	304
PeCDD	356	293	354	291
¹³ C ₁₂ -PeCDF	352	288	350	286
PCDF	340	277	338	275
¹³ C ₁₂ -HxCDD	404	340	402	338
HxCDD	390	327	392	329
¹³ C ₁₂ -HxCDF	388	324	386	322
HxCDF	374	311	376	313
¹³ C ₁₂ -HpCDD	436	372	438	374
HpCDD	424	361	426	363
¹³ C ₁₂ -HpCDF	420	356	422	358
HpCDF	408	345	410	347
¹³ C ₁₂ -OCDD	472	408	470	406
OCDD	458	395	460	397
¹³ C ₁₂ -OCDF	454	390	456	392
OCDF	442	379	444	381

Table OTM49-5. Example MRM Transitions for PAH²⁹

Compound	Quant. Precursor Ion m/z	Quant. Product Ion m/z	Qual. Precursor Ion m/z	Qual. Product Ion m/z
¹³ C ₆ -Naphthalene	134	83	134	108
Naphthalene	128	77	128	102
¹³ C ₆ -2-Methylnaphthalene	148	147	148	121
2-Methylnaphthalene	142	141	142	115
¹³ C ₆ -Acenaphthalene	158	132	158	108
Acenaphthalene	152	102	152	126
¹³ C ₆ -Acenaphthene	159	132	159	157
Acenaphthene	153	126	153	151
¹³ C ₆ -Fluorene	171	146	171	169
Fluorene	165	139	165	163
¹³ C ₆ -Phenanthrene	184	158	184	182
Phenanthrene	178	152	178	176
¹³ C ₆ -Anthracene	184	158	184	182
Anthracene	178	152	178	176
¹³ C ₆ -Fluoranthene	208	206	208	182
Fluoranthene	202	200	202	176
¹³ C ₃ -Pyrene	205	179	205	203
Pyrene	202	176	202	200
¹³ C ₆ -Benzo[<i>a</i>]anthracene	234	232	234	208
Benzo[<i>a</i>]anthracene	228	226	228	202
¹³ C ₆ -Chrysene	234	208	234	232
Chrysene	228	202	228	226
¹³ C ₆ -Benzo[<i>b</i>]fluoranthene	258	232	258	256
Benzo[<i>b</i>]fluoranthene	252	226	252	250
¹³ C ₆ -Benzo[<i>k</i>]fluoranthene	258	232	258	256
Benzo[<i>k</i>]fluoranthene	252	226	252	250
¹³ C ₄ -Benzo[<i>e</i>]pyrene	256	256	256	254
Benzo[<i>e</i>]pyrene	252	252	252	250
¹³ C ₄ -Benzo[<i>a</i>]pyrene	256	230	256	254
Benzo[<i>a</i>]pyrene	252	226	252	250
d ₁₂ -Perylene	264	230	264	260
Perylene	252	252	252	250
¹³ C ₆ -Indeno[<i>1,2,3-cd</i>]pyrene	282	278	282	280
Indeno[<i>1,2,3-cd</i>]pyrene	276	272	276	274
¹³ C ₆ -Dibenz[<i>a,h</i>]anthracene	284	282	284	282
Dibenz[<i>a,h</i>]anthracene	278	274	278	276
¹³ C ₁₂ -Benzo[<i>g,h,i</i>]perylene	288	284	288	286
Benzo[<i>g,h,i</i>]perylene	276	272	278	274

Note: Quantitation and qualitative ions may be exchanged.

Table OTM49-6. Example MRM Transitions for PCB³⁰

Compound	Quant. Precursor Ion m/z	Quant. Product Ion m/z	Qual. Precursor Ion m/z	Qual. Product Ion m/z
MoCBs	188	153	190	153
¹³ C-MoCBs	200	165	202	165
DiCBs	222	152	224	152
¹³ C-DiCBs	234	164	236	164
TrCBs	256	186	258	186
¹³ C-TrCBs	268	198	270	198
TeCBs	290	220	292	220
¹³ C-TeCBs	302	232	304	232
PeCBs	324	254	326	256
¹³ C-PeCBs	336	266	337	268
HxCBs	360	290	362	290
¹³ C-HxCBs	372	302	370	300
HpCBs	396	326	394	324
¹³ C-HpCBs	406	336	406	336
OcCBs	428	358	430	358
¹³ C-OcCBs	440	370	442	370
NoCBs	462	392	464	394
¹³ C-NoCBs	474	404	476	406
DeCBs	496	426	498	428
¹³ C-DeCBs	508	438	510	440

Table OTM49-7. Concentration of the Sample Fortification for PCDD and PCDF^a

Compound	pg/μL of final extract ^b	Spike Recovery
Pre-sampling Adsorbent Standard		
¹³ C ₁₂ -1,2,3,4-TeCDD	50	70-130%
¹³ C ₁₂ -1,2,3,4,7-PeCDD	50	70-130%
¹³ C ₁₂ -1,2,3,4,6-PeCDF	50	70-130%
¹³ C ₁₂ -1,2,3,4,6,9-HxCDF	50	70-130%
¹³ C ₁₂ -1,2,3,4,6,8,9-HpCDF	50	70-130%
Pre-extraction Filter Recovery Standard		
¹³ C ₁₂ -1,2,7,8-TeCDF	100	70-130%
¹³ C ₁₂ -1,2,3,4,6,8-HxCDD	100	70-130%
Pre-extraction Standard		
¹³ C ₁₂ -2,3,7,8-TeCDD	100	20-130%
¹³ C ₁₂ -2,3,7,8-TeCDF	100	20-130%
¹³ C ₁₂ -1,2,3,7,8-PeCDD	100	20-130%
¹³ C ₁₂ -1,2,3,7,8-PeCDF	100	20-130%
¹³ C ₁₂ -2,3,4,7,8-PeCDF	100	20-130%
¹³ C ₁₂ -1,2,3,4,7,8-HxCDD	100	20-130%
¹³ C ₁₂ -1,2,3,6,7,8-HxCDD	100	20-130%

Compound	pg/ μ L of final extract ^b	Spike Recovery
¹³ C ₁₂ -1,2,3,7,8,9-HxCDD	100	20-130%
¹³ C ₁₂ -1,2,3,4,7,8-HxCDF	100	20-130%
¹³ C ₁₂ -1,2,3,6,7,8-HxCDF	100	20-130%
¹³ C ₁₂ -2,3,4,6,7,8-HxCDF	100	20-130%
¹³ C ₁₂ -1,2,3,7,8,9-HxCDF	100	20-130%
¹³ C ₁₂ -1,2,3,4,6,7,8-HpCDD	100	20-130%
¹³ C ₁₂ -1,2,3,4,6,7,8-HpCDF	100	20-130%
¹³ C ₁₂ -1,2,3,4,7,8,9-HpCDF	100	20-130%
¹³ C ₁₂ -OCDD	200	20-130%
¹³ C ₁₂ -OCDF	200	20-130%
Pre-analysis Standard		
¹³ C ₁₂ -1,3,6,8-TeCDD	100	S/N \geq 5
¹³ C ₁₂ -1,2,3,4-TeCDF	100	S/N \geq 5
¹³ C ₁₂ -1,2,3,4,6,7-HxCDD	100	S/N \geq 5
¹³ C ₁₂ -1,2,3,4,6,7,9-HpCDD	100	S/N \geq 5
Alternate Recovery Standard		
¹³ C ₁₂ -1,3,7,8-TeCDD	100	20-130%
¹³ C ₁₂ -1,2,4,7,8-PeCDD	100	20-130%

^a Changes in the amounts of spike standards added to the sample or its representative extract will necessitate an adjustment of the calibration solutions to prevent the introduction of inconsistencies. Spike concentration assumes 1 μ L sample injection volume for analysis.

^b Spike levels assume half of the extract will be archived before cleanup. Spike levels may be adjusted for different split levels.

Note: all standards used should be reported.

Table OTM49-8. Concentration of the Sample Fortification for PAH^a

Compound	pg/ μ L of final extract ^b	Spike Recovery
Pre-sampling Adsorbent Standard		
¹³ C ₆ -Benzo[<i>c</i>]fluorene	100	70-130%
¹³ C ₁₂ -Benzo[<i>j</i>]fluoranthene	100	70-130%
Pre-extraction Filter Recovery Standard		
d ₁₀ -Anthracene	100	70-130%
Pre-extraction Standard		
¹³ C ₆ -Naphthalene	100	20-130%
¹³ C ₆ -2-Methylnaphthalene	100	20-130%
¹³ C ₆ -Acenaphthylene	100	20-130%
¹³ C ₆ -Acenaphthene	100	20-130%
¹³ C ₆ -Fluorene	100	20-130%
¹³ C ₆ -Phenanthrene	100	20-130%
¹³ C ₆ -Anthracene	100	20-130%
¹³ C ₆ -Fluoranthene	100	20-130%

Compound	pg/ μ L of final extract ^b	Spike Recovery
¹³ C ₃ -Pyrene	100	20-130%
¹³ C ₆ -Benzo[<i>a</i>]anthracene	100	20-130%
¹³ C ₆ -Chrysene	100	20-130%
¹³ C ₆ -Benzo[<i>b</i>]fluoranthene	100	20-130%
¹³ C ₆ -Benzo[<i>k</i>]fluoranthene	100	20-130%
¹³ C ₄ -Benzo[<i>e</i>]pyrene	100	20-130%
¹³ C ₄ -Benzo[<i>a</i>]pyrene	100	20-130%
d ₁₂ -Perylene	100	20-130%
¹³ C ₆ -Indeno[<i>1,2,3-cd</i>]pyrene	100	20-130%
¹³ C ₆ -Dibenz[<i>a,h</i>]anthracene	100	20-130%
¹³ C ₁₂ -Benzo[<i>g,h,i</i>]perylene	100	20-130%
Pre-analysis Standard		
d ₁₀ -Acenaphthene	100	S/N \geq 5
d ₁₀ -Pyrene	100	S/N \geq 5
d ₁₂ -Benzo[<i>e</i>]pyrene	100	S/N \geq 5

^a Changes in the amounts of spike standards added to the sample or its representative extract will necessitate an adjustment of the calibration solutions to prevent the introduction of inconsistencies.

^b Spike levels assume half of the extract will be archived before cleanup. You may adjust spike levels for different split levels.

Note: all standards used should be reported.

Table OTM49-9. Concentration of the Sample Fortification for PCB^a

Compound	BZ No. ^b	pg/ μ L of final extract ^c	Spike Recovery
Pre-sampling Adsorbent Standard			
¹³ C ₁₂ -3,3'-DiCB	11L	100	70-130%
¹³ C ₁₂ -2,4',5'-TrCB	31L	100	70-130%
¹³ C ₁₂ -2,2',3,5',6'-PeCB	95L	100	70-130%
¹³ C ₁₂ -2,2',4,4',5,5'-HxCB	153L	100	70-130%
Pre-extraction Filter Recovery Spike Standard			
¹³ C ₁₂ -2,3,3',4,5,5'-HxCB	159L	100	70-130%
Pre-extraction Standard			
¹³ C ₁₂ -2-MoCB (WDC)	1L	100	20-145%
¹³ C ₁₂ -4-MoCB (WDC)	3L	100	20-145%
¹³ C ₁₂ -2,2'-DiCB (WDC)	4L	100	20-145%
¹³ C ₁₂ -4,4'-DiCB (WDC)	15L	100	20-145%
¹³ C ₁₂ -2,2',6'-TrCB (WDC)	19L	100	20-145%
¹³ C ₁₂ -3,4',4'-TrCB (WDC)	37L	100	20-145%
¹³ C ₁₂ -2,2',6,6'-TeCB (WDC)	54L	100	20-145%
¹³ C ₁₂ -3,3',4,4'-TeCB (WDC)	77L	100	20-145%
¹³ C ₁₂ -3,4,4',5'-TeCB	81L	100	20-145%
¹³ C ₁₂ -2,2',4,6,6'-PeCB (WDC)	104L	100	20-145%

Compound	BZ No. ^b	pg/ μ L of final extract ^c	Spike Recovery
¹³ C ₁₂ -2,3,3',4,4'-PeCB	105L	100	20-145%
¹³ C ₁₂ -2,3,4,4',5-PeCB	114L	100	20-145%
¹³ C ₁₂ -2,3',4,4',5-PeCB	118L	100	20-145%
¹³ C ₁₂ -2',3,4,4',5-PeCB	123L	100	20-145%
¹³ C ₁₂ -3,3',4,4',5-PeCB (WDC)	126L	100	20-145%
¹³ C ₁₂ -2,2',4,4',6,6'-HxCB (WDC)	155L	100	20-145%
¹³ C ₁₂ -2,3,3',4,4',5-HxCB	156L	100	20-145%
¹³ C ₁₂ -2,3,3',4,4',5'-HxCB	157L	100	20-145%
¹³ C ₁₂ -2,3',4,4',5,5'-HxCB	167L	100	20-145%
¹³ C ₁₂ -3,3',4,4',5,5'-HxCB (WDC)	169L	100	20-145%
¹³ C ₁₂ -2,2',3,3',4,4',5'-HpCB	170L	100	20-145%
¹³ C ₁₂ -2,2',3,4,4',5,5'-HpCB	180L	100	20-145%
¹³ C ₁₂ -2,2',3,4',5,6,6'-HpCB (WDC)	188L	100	20-145%
¹³ C ₁₂ -2,3,3',4,4',5,5'-HpCB (WDC)	189L	100	20-145%
¹³ C ₁₂ -2,2',3,3',5,5',6,6'-OxCB (WDC)	202L	100	20-145%
¹³ C ₁₂ -2,3',3',4,4',5,5',6-OxCB (WDC)	205L	100	20-145%
¹³ C ₁₂ -2,2',3,3',4,4',5,5',6-NoCB (WDC)	206L	100	20-145%
¹³ C ₁₂ -2,2',3,3',4,5,5',6,6'-NoCB (WDC)	208L	100	20-145%
¹³ C ₁₂ -DeCB (WDC)	209L	100	20-145%
Pre-analysis Standard			
¹³ C ₁₂ -2,5-DiCB	9L	100	S/N \geq 5
¹³ C ₁₂ -2,2',5,5'-TeCB	52L	100	S/N \geq 5
¹³ C ₁₂ -2,2',4,5,5'-PeCB	101L	100	S/N \geq 5
¹³ C ₁₂ -2,2',3,4,4',5'-HxCB	138L	100	S/N \geq 5
¹³ C ₁₂ -2,2',3,3',4,4',5,5'-OxCB	194L	100	S/N \geq 5
Optional Cleanup Spiking Standard			
¹³ C ₁₂ -2-MoCB	28L	100	20-130%
¹³ C ₁₂ -2,2',4,5,5'-PeCB	111L	100	20-130%
¹³ C ₁₂ -2,2',3,3',5,5',6,6'-OxCB	178L	100	20-130%
Alternate Recovery Standard			
¹³ C ₁₂ -2,3',4',5'-TeCB	70L	100	20-130%
¹³ C ₁₂ -2,3,4,4'-TeCB	60L	100	20-130%
¹³ C ₁₂ -3,3',4,5,5'-PeCB	127L	100	20-130%

^a Changes in the amounts of spike standards added to the sample or its representative extract will necessitate an adjustment of the calibration solutions to prevent the introduction of inconsistencies.

^b BZ No.: Ballschmider and Zell 1980, or IUPAC number.

^c Spike levels assume half of the extract will be archived before cleanup. Spike levels may be adjusted for different split levels.

Many of the listed PCB are considered toxic by the National Oceanic and Atmospheric Administration and/or the World Health Organization.

Note: all standards used should be reported.

Table OTM49-10. Sample Storage Conditions^a and Laboratory Hold Times^b

Sample Type	PCDD/PCDF	PAH	PCB
Field Storage and Shipping Conditions			
All Field Samples	≤ 20°C, (68 °F)	≤ 20 °C, (68 °F)	≤ 20 °C, (68 °F)
Laboratory Storage Conditions			
Sampling Train Rinses and Filters	≤ 6 °C (43 °F)	≤ 6 °C (43 °F)	≤ 6 °C (43 °F)
Adsorbent	≤ 6 °C (43 °F)	≤ 6 °C (43 °F)	≤ 6 °C (43 °F)
Extract and Archive	< 26 °C (79 °F) ^c	< -10 °C (14 °F)	< -10 °C (14 °F)
Laboratory Hold Times			
Extract and Archive	One year	45 Days	One year

^a All samples must be stored in the dark.

^b Hold times begin from the time the laboratory receives the samples.

^c Room temperature is acceptable if PCDD/PCDF are the only target compounds.

Note: Hold times for PCDD/PCDF and PCB are recommendations.

Table OTM49-11. Concentration of the Initial Calibration Standard Solutions for PCDD and PCDF^a (pg/μL)

Standard Compound	Cal 1 (optional)	Cal 2	Cal 3	Cal 4	Cal 5	Cal 6	Cal 7 (optional)
Target (Unlabeled) Analytes	0.50	1.0	5.0	10.0	25	50	100
Pre-sampling Adsorbent Standard	50	50	50	50	50	50	50
Pre-extraction Filter Recovery Standard	50	50	50	50	50	50	50
Pre-extraction Standard	50	50	50	50	50	50	50
Pre-analysis Standard	50	50	50	50	50	50	50
Alternate Recovery Standard	50	50	50	50	50	50	50

^a Assumes 1 μL injection volume.

Table OTM49-12. Concentration of the Initial Calibration Standard Solutions for PAH^a (pg/μL)

Standard Compound	Cal 1 (optional)	Cal 2	Cal 3	Cal 4	Cal 5	Cal 6	Cal 7 (optional)
Target (Unlabeled) Analytes	1	2	4	20	80	400	1,000
Pre-sampling Adsorbent Standard	100	100	100	100	100	100	100
Pre-extraction Filter Recovery Standard	100	100	100	100	100	100	100
Pre-extraction Standard	100	100	100	100	100	100	100
Pre-analysis Standard	100	100	100	100	100	100	100

^a Assumes 1 μL injection volume.

Table OTM49-13. Concentration of the Initial Calibration Standard Solutions for PCB^a (pg/μL)

Standard Compound	Cal 1 (optional)	Cal 2	Cal 3	Cal 4	Cal 5	Cal 6	Cal 7 (optional)
Target (Unlabeled) Analytes	0.50	1	5	10	50	400	2,000
Pre-sampling Adsorbent Standard	100	100	100	100	100	100	100
Pre-extraction Filter Recovery Standard	100	100	100	100	100	100	100
Pre-extraction Standard	100	100	100	100	100	100	100
Pre-analysis Standard	100	100	100	100	100	100	100
Alternate Standard	100	100	100	100	100	100	100

^a Assumes 1 μL injection volume.

Table OTM49-14. Minimum Requirements for Initial and Continuing Calibration Response Factors for Isotopically Labeled and Native Compounds

Analyte Group	Initial Calibration RSD (percent difference)	Continuing Calibration RRF (percent difference)
Native (Unlabeled) Analytes	10	25
Pre-sampling Adsorbent Standard	20	25
Pre-extraction Filter Recovery Standard	20	25
Pre-extraction Standard	20	30
Pre-analysis Standard	20	30
Alternative Recovery Standard	20	30

Table OTM49-15. Recommended Ion Type and Transition Ion Ratios

No. of Chlorine Atoms	Ion Type	Theoretical Ratio	Lower Limit	Upper Limit
1	M/M+2	3.13	2.66	3.60
2	M/M+2	1.56	1.33	1.79
3	M/M+2	1.04	0.88	1.20
4	M/M+2	0.77	0.65	0.89
5	M+2/M+4	1.55	1.32	1.78
6	M+2/M+4	1.24	1.05	1.43
6 ^a	M/M+2	0.51	0.43	0.59
7	M+2/M+4	1.05	0.89	1.21
7 ^b	M/M+2	0.44	0.37	0.51
8	M+2/M+4	0.89	0.76	1.02
9	M+2/M+4	0.77	0.65	0.89
10	M+4/M+6	1.16	0.99	1.33

^a Used only for ¹³C-HxCDF

^b Used only for ¹³C-HpCDF.

Table OTM49-16. Suggested GC Operating Conditions

Column Parameter	PCDD/PCDF	PAH	PCB
GC Column	DB-5 or DB-225	DB-5/30meter	SPB-octyl
Injector temperature	270 °C	320 °C	270 °C
Interface temperature	290 °C	290 °C	290 °C
Initial oven temperature	20 °C	45 °C	75 °C
Initial hold time (minutes)	2 minutes (min)	4 min	2 min
Temperature program	20 to 220 °C at 5 °C/min, 220 °C for 16 min, then 220 to 235 °C at 5°C/min, 235 °C for 7 min, 235 °C to 330 °C at 5 °C /min	45 to 300 °C at 8°C/min	75 to 150 °C at 15 °C/min, then 150 to 190 °C at 2.5 °C/min Note: RT of PCB 209 must exceed 55 min on this column

Table OTM49-17. Assignment of Pre-extraction Standards for Quantitation of Target PCB^b

PCB Congener	BZ No. ^a	Labeled Analog	BZ No.
2,4'-DiCB	8	¹³ C ₁₂ -2,2'-DiCB	4L
2,2',5-TrCB	18	¹³ C ₁₂ -2,2',6-TrCB	19L
2,4,4'-TrCB	28	¹³ C ₁₂ -2,2',6-TrCB	19L
2,2',3,5'-TeCB	52	¹³ C ₁₂ -2,2',6,6'-TeCB	54L
2,2',5,5'-TeCB	52	¹³ C ₁₂ -2,2',6,6'-TeCB	54L
2,3',4,4'-TeCB	66	¹³ C ₁₂ -2,2',6,6'-TeCB	54L
3,3',4,4'-TeCB	77	¹³ C ₁₂ -3,3',4,4'-TeCB	77L
3,4,4',5-TeCB	81	¹³ C ₁₂ -3,4,4',5-TeCB	81L
2,2',4,5,5'-PeCB	101	¹³ C ₁₂ -2,2',4,5,5'-PeCB	104L
2,3,3',4,4'-PeCB	105	¹³ C ₁₂ -2,3,3',4,4'-PeCB	105L
2,3,4,4',5-PeCB	114	¹³ C ₁₂ -2,3,4,4',5-PeCB	114L
2,3',4,4',5-PeCB	118	¹³ C ₁₂ -2,3',4,4',5-PeCB	118L
2',3,4,4',5-PeCB	123	¹³ C ₁₂ -2',3,4,4',5-PeCB	123L
3,3',4,4',5-PeCB	126	¹³ C ₁₂ -3,3',4,4',5-PeCB	126L
2,2',3,3',4,4'-HxCB	128	¹³ C ₁₂ -2,2',4,4',6,6'-HxCB	155L
2,2',3,4,4',5'-HxCB	138	¹³ C ₁₂ -2,2',4,4',6,6'-HxCB	155L
2,2',4,4',5,5'-HxCB	153	¹³ C ₁₂ -2,2',4,4',6,6'-HxCB	155L
2,3,3',4,4',5-HxCB	156	¹³ C ₁₂ -2,3,3',4,4',5-HxCB	156L
2,3,3',4,4',5'-HxCB	157	¹³ C ₁₂ -2,3,3',4,4',5'-HxCB	157L
2,3',4,4',5,5'-HxCB	167	¹³ C ₁₂ -2,3',4,4',5,5'-HxCB	167L
3,3',4,4',5,5'-HxCB	169	¹³ C ₁₂ -3,3',4,4',5,5'-HxCB	169L
2,2',3,3',4,4',5-HpCB	170	¹³ C ₁₂ -2,2',3,3',4,4',5'-HpCB	170L
2,2',3,4,4',5,5'-HpCB	180	¹³ C ₁₂ -2,2',3,4,4',5,5'-HpCB	180L
2,2',3,4',5,5',6-HpCB	187	¹³ C ₁₂ -2,2',3,4',5,6,6'-HpCB	188L
2,3,3',4,4',5,5'-HpCB	189	¹³ C ₁₂ -2,3,3',4,4',5,5'-HpCB	189L
2,2',3,3',4,4',5,6-OcCB	195	¹³ C ₁₂ -2,2',3,3',5,5',6,6'-OcCB	202L
2,2',3,3',4,4',5,5',6-NoCB	206	¹³ C ₁₂ -2,2',3,3',4,4',5,5',6-NoCB	206L
2,2',3,3',4,4',5,5',6,6'-DeCB	209	¹³ C ₁₂ -DeCB	209L

^a BZ No.: Ballschmiter and Zell 1980, or IUPAC number.

^b Assignments assume the use of the SPB-Octyl column. In the event you choose another column, you may select the labeled standard having the same number of chlorine substituents and the closest retention time to the target analyte in question as the labeled standard to use for quantitation.

Listed PCB are considered toxic by the National Oceanic and Atmospheric Administration and/or the World Health Organization.

Table OTM49-18. Initial Demonstration of Capability QC Requirements

Section	Requirement	Specification and Frequency	Acceptance Criteria
9.2.2.3.2	Demonstration of low system background	Analyze an LMB after the highest calibration standard. Note: If an automated extraction system is used, an LMB must be extracted on each port.	Confirm that the LMB is free from contamination as defined in Section 9.2.6.3.
9.2.2.4	Determination of MDL	Prepare, extract, and analyze 7 replicate spiked samples (spiked within 2 to 10 times of the expected MDL) and 7 LMBs. See 40 CFR Part 136 Appendix B for details.	See MDL confirmation.
9.2.2.4.1	MDL confirmation	Prepare, extract, and analyze a spiked sample (spiked at the MDL).	Confirm that the target compounds meet the qualitative identification criteria in Section 9.3 of this method.
9.2.2.1	Demonstration of precision	Prepare, extract, and analyze 7 replicate spiked samples (spiked near mid-range).	Percent relative standard deviation must be $\leq 20\%$.
9.2.2.2	Demonstration of accuracy	Calculate mean recovery for replicate spiked samples in Section 9.3.9.	Mean recovery within 70-130% of true value.
9.2.2.3	Lowest Calibration Concentration Confirmation	Establish a target concentration for the lowest calibration based on the intended use of the method.	Upper PIR $\leq 150\%$ and Lower PIR $\geq 50\%$.
9.2.2.5	Calibration Verification	Analyze a mid-level QCS.	Results must be within 70-130% of the true value.

Table OTM49-19. General QA/QC Requirements

Section	Requirement	Specification and Frequency	Acceptance Criteria	Consequences and Corrective Actions
Sampling QC (Section 9.1)				
9.1.3	Field Train Proof Blank (FTPB)	At least one FTPB per each test series.	Levels $\leq 10\%$ of actual samples.	If $> 10\%$, flag data and assess impact on results.
9.2.7.1	Pre-Sampling Adsorbent Standard	Added to each XAD-2 adsorbent cartridge prior to sampling. Indicates sample collection and recovery efficiency.	$\geq 70\%$ and $\leq 130\%$ recovery of all spike standards.	Recoveries below the acceptable range of 70-130% for the pre-sampling adsorbent standard spikes may require a root cause evaluation. If the recovery of all the pre-sampling adsorbent standard spikes is below 70%, but, greater than 50%, the results have not met the recoveries experienced during method development but may still be acceptable. Flag recoveries that are between 50 and 70% and describe their potential impact on results. If the pre-sampling adsorbent standard recoveries are less than 50%, the data for that train are not considered valid.
Ongoing QC Requirements (Section 9.2)				
9.2.6.2	Sampling Media Background Level Checks	Confirm sample media background before use for sampling.	Levels should be \leq compound MDL.	If $> MDL$, further clean sampling media until levels are $\leq MDL$.
9.2.6.3	Laboratory Method Blank (LMB)	Analyze a LMB for each sampling medium and reagent with each extraction batch and ≥ 1 LMB when method analytes exceed the calibration range.	Levels should be \leq compound MDL.	If $> MDL$, flag data and assess impact on results. Resolve source of contamination before proceeding to additional analyses.
9.2.4	Initial Calibration Acceptance Criteria	Evaluate the initial concentration of each analyte as an unknown against its regression equation (Section 10.5).	Between 70-130% of each analyte true value (for Cal 1, 50-150% of each analyte true value).	Reanalyze the calibration standards, restrict the range of calibration, or perform instrument maintenance. If failure is due to contamination or standard degradation, prepare fresh calibration standards and repeat initial calibration.

9.2.5	Continuing Calibration Check (CCC)	Analyze CCC at the beginning of each analysis batch, after every tenth field sample, and at the end of the analysis batch.	Beginning CCC must be equal to or lower than QRL for each analyte. Must be within 70-130% of true value.	If the CCC fails because concentration is >130% (150% for low-level CCC) and field sample extracts show no concentrations above the MDL for that analyte, non-detects can be reported without re-analysis. See Section 9.2.5.4 for Corrective Action.
9.2.6.6	Laboratory Fortified Media Blanks (LFMB)	Duplicate low and high LFMBs are required with each extraction batch for each fraction.	Analytes fortified near or at the lowest calibration point must be within 50-150% of the true value. Analytes fortified at all other concentrations must be within 70-130% of the true value.	If the LFMB results do not meet these criteria, the laboratory must investigate the cause for this failure, report their findings and corrective action. Then report all data for the problem analytes with a note that LFMB accuracy criteria were not met.
9.2.7.3	Pre-Analysis Standard Areas	The analyst must monitor the peak areas of the pre-analysis standards in all injections of the analysis batch.	The pre-analysis standards (as indicated by peak area) in any chromatographic run must be within 50-150% of the average area measured during in the initial calibration.	If criteria is not met, reanalyze the extract in a subsequent analysis batch. If the pre-analysis standard(s) area fails to meet the acceptance criteria in the repeat analysis, or if multiple samples in a batch fail to meet the pre-analysis spike criteria, perform corrective action and reanalyze the failed samples extract.
9.2.7.2	Pre-Extraction Isotope Dilution	For each sample fraction, calculate the concentration and percent recovery of each isotope dilution analogue in field and QC samples using the average area in the initial calibration and internal standard.	Percent recovery must be within a range of 20-130%	Recoveries below the acceptable range for pre-extraction spikes are an indication that sample preparation procedures did not adequately address sample and or sample matrix processing to recover native target compounds. Compounds that fail this criterion should be flagged and reported as not quantitative because of QC failure. If this failure involves target compounds that are critical to the test objectives, this is a failure that requires root cause investigation and may require a repeat field sampling effort.

9.2.2.5	Calibration Verification using Quality Control Standard (QCS)	Perform a calibration verification during the IDC and at least quarterly after.	Results must be within 70-130% of the true value.	If accuracy fails, prepare fresh standard dilutions and repeat the calibration verification.
9.6	Method Modification QC Requirements	Perform after modifying chromatographic and MS/MS conditions.	Must pass IDC criteria. Must evaluate and document method performance in an archived field sample.	Repeat until IDC is passed.

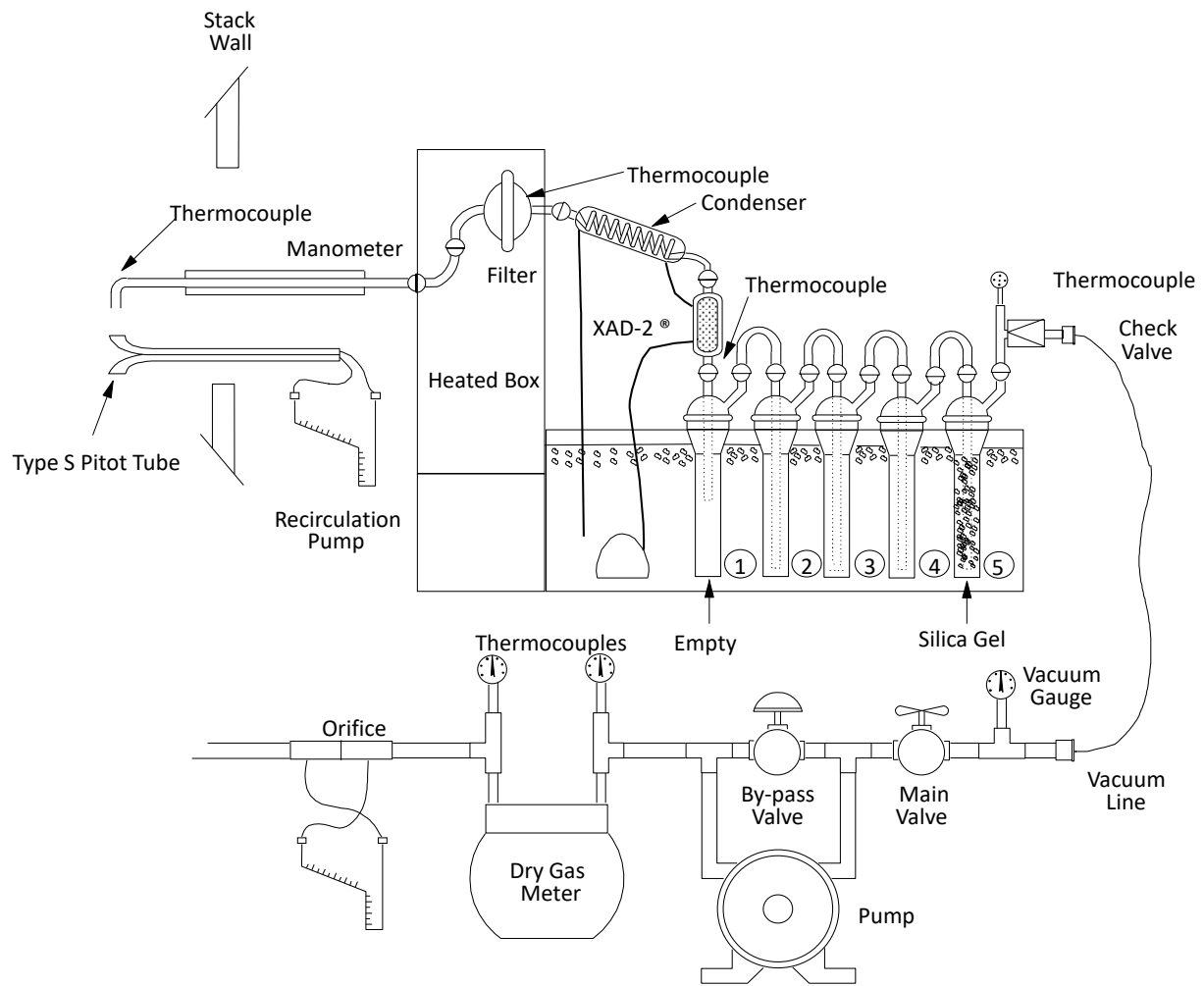

Figure OTM49-1. Sampling Train

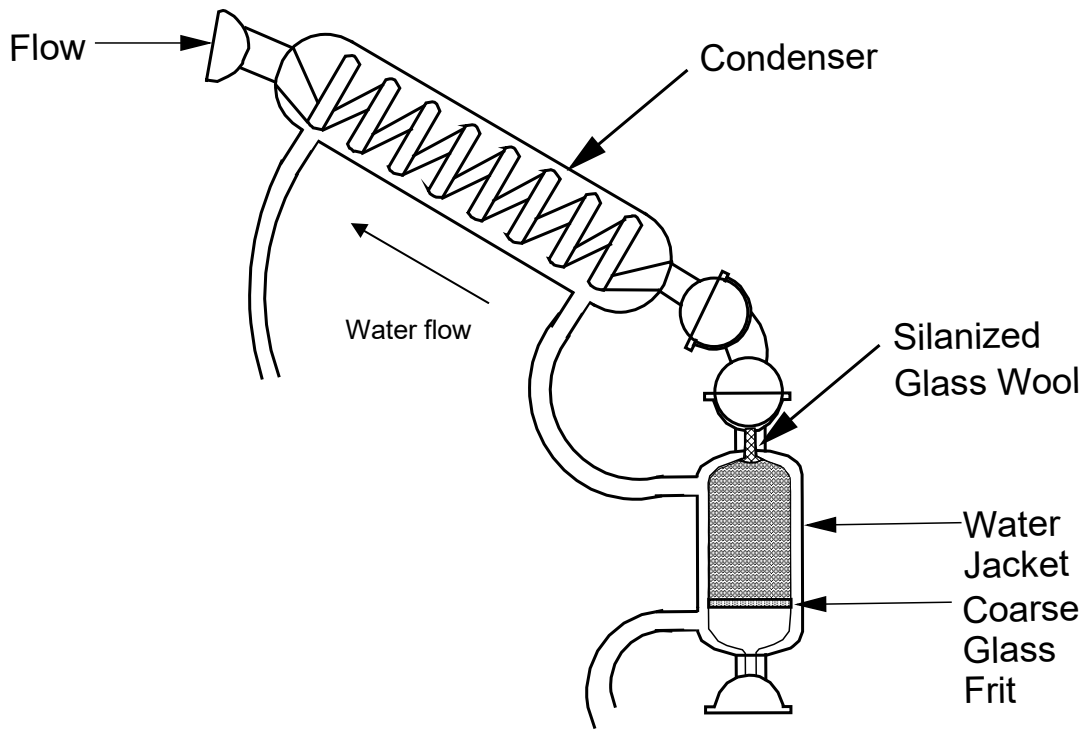

Figure OTM49-2. Condenser and Adsorbent Module

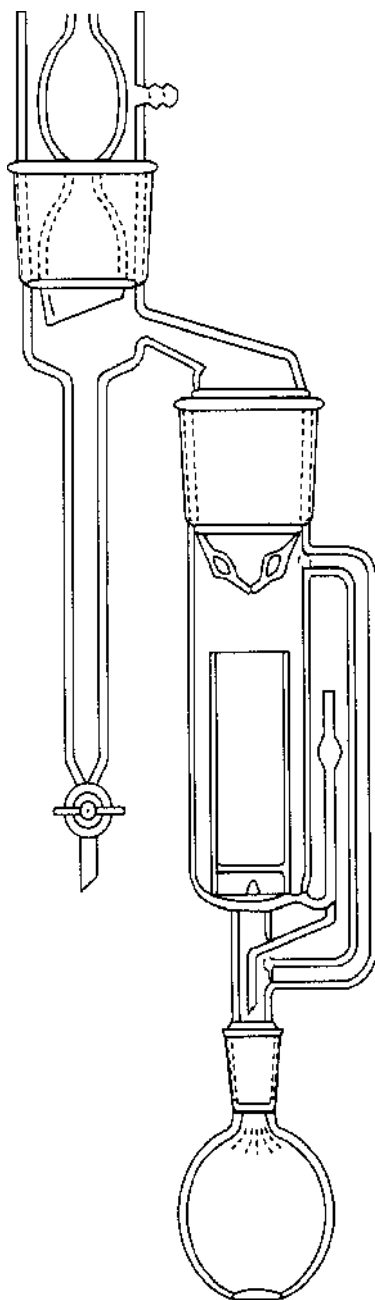

Figure OTM49-3. Soxhlet/Dean-Stark Extractor

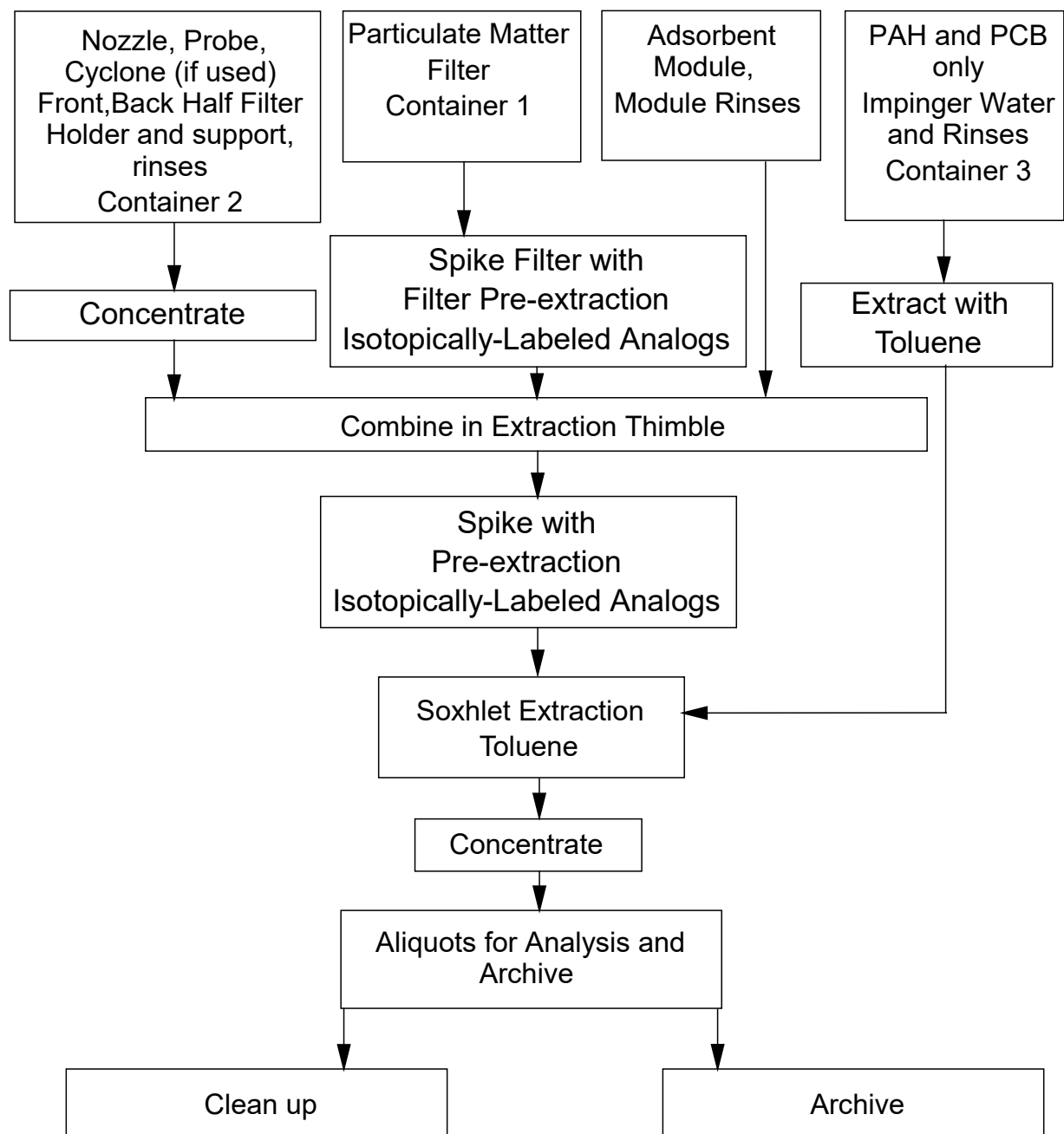

Figure OTM49-4. Sample Preparation Flow Chart

Appendix A

Complete List of 209 PCB Congeners and Their Isomers with Corresponding Isotope Dilution Quantitation Standards^a

Pre-extraction Standard	BZ ^b No.	Unlabeled Target Analyte	BZ ^b No.	Pre-extraction Standard	BZ ^b No.	Unlabeled Target Analyte	BZ ^b No.
MoCB				DiCB			
¹³ C ₁₂ -2-MoCB	1L	2-MoCB	1	¹³ C ₁₂ -2,2'-DiCB	4L	2,2'-DiCB	4
¹³ C ₁₂ -2-MoCB	1L	3-MoCB	2	¹³ C ₁₂ -2,2'-DiCB	4L	2,3-DiCB	5
¹³ C ₁₂ -4-MoCB	3L	4-MoCB	3	¹³ C ₁₂ -2,2'-DiCB	4L	2,3'-DiCB	6
				¹³ C ₁₂ -2,2'-DiCB	4L	2,4-DiCB	7
				¹³ C ₁₂ -2,2'-DiCB	4L	2,4'-DiCB	8
				¹³ C ₁₂ -2,2'-DiCB	4L	2,5-DiCB	9
				¹³ C ₁₂ -2,2'-DiCB	4L	2,6-DiCB	10
				¹³ C ₁₂ -2,2'-DiCB	4L	3,3'-DiCB	11
				¹³ C ₁₂ -2,2'-DiCB	4L	3,4-DiCB	12
				¹³ C ₁₂ -2,2'-DiCB	4L	3,4'-DiCB	13
				¹³ C ₁₂ -2,2'-DiCB	4L	3,5-DiCB	14
				¹³ C ₁₂ -4,4'-DiCB	15L	4,4'-DiCB	15
TrCB							
¹³ C ₁₂ -2,2',6-TrCB	19L	2,2',3-TrCB	16	¹³ C ₁₂ -3,4,4'-TrCB	19L	2,4,4'-TrCB	28
¹³ C ₁₂ -2,2',6-TrCB	19L	2,2',4-TrCB	17	¹³ C ₁₂ -3,4,4'-TrCB	19L	2,4,5-TrCB	29
¹³ C ₁₂ -2,2',6-TrCB	19L	2,2',5-TrCB	18	¹³ C ₁₂ -3,4,4'-TrCB	19L	2,4,6-TrCB	30
¹³ C ₁₂ -2,2',6-TrCB	19L	2,2',6-TrCB	19	¹³ C ₁₂ -3,4,4'-TrCB	19L	2,4',5-TrCB	31
¹³ C ₁₂ -2,2',6-TrCB	19L	2,3,3'-TrCB	20	¹³ C ₁₂ -3,4,4'-TrCB	19L	2,4',6-TrCB	32
¹³ C ₁₂ -2,2',6-TrCB	19L	2,3,4-TrCB	21	¹³ C ₁₂ -3,4,4'-TrCB	19L	2',3,4-TrCB	33
¹³ C ₁₂ -2,2',6-TrCB	19L	2,3,4'-TrCB	22	¹³ C ₁₂ -3,4,4'-TrCB	19L	2',3,5-TrCB	34
¹³ C ₁₂ -2,2',6-TrCB	19L	2,3,5-TrCB	23	¹³ C ₁₂ -3,4,4'-TrCB	19L	3,3',4-TrCB	35
¹³ C ₁₂ -2,2',6-TrCB	19L	2,3,6-TrCB	23	¹³ C ₁₂ -3,4,4'-TrCB	19L	3,3',5-TrCB	36
¹³ C ₁₂ -2,2',6-TrCB	19L	2,3',4-TrCB	25	¹³ C ₁₂ -3,4',4'-TrCB	37L	3,4,4'-TrCB	37
¹³ C ₁₂ -2,2',6-TrCB	19L	2,3',5-TrCB	26	¹³ C ₁₂ -3,4',4'-TrCB	37L	3,4,5-TrCB	38
¹³ C ₁₂ -2,2',6-TrCB	19L	2,3',6-TrCB	27	¹³ C ₁₂ -3,4',4'-TrCB	37L	3,4',5-TrCB	39
TeCB							
¹³ C ₁₂ -2,2',6,6'-TeCB	54L	2,2',3,3'-TeCB	40	¹³ C ₁₂ -2,2',6,6'-TeCB	54L	2,3,4,5-TeCB	61

Pre-extraction Standard	BZ ^b No.	Unlabeled Target Analyte	BZ ^b No.	Pre-extraction Standard	BZ ^b No.	Unlabeled Target Analyte	BZ ^b No.
¹³ C ₁₂ -2,2',6,6'-TeCB	54L	2,2',3,4-TeCB	41	¹³ C ₁₂ -2,2',6,6'-TeCB	54L	2,3,4,6-TeCB	62
¹³ C ₁₂ -2,2',6,6'-TeCB	54L	2,2',3,4'-TeCB	42	¹³ C ₁₂ -2,2',6,6'-TeCB	54L	2,3,4',5-TeCB	63
¹³ C ₁₂ -2,2',6,6'-TeCB	54L	2,2',3,5-TeCB	43	¹³ C ₁₂ -2,2',6,6'-TeCB	54L	2,3,4',6-TeCB	64
¹³ C ₁₂ -2,2',6,6'-TeCB	54L	2,2',3,5'-TeCB	44	¹³ C ₁₂ -2,2',6,6'-TeCB	54L	2,3,5,6-TeCB	65
¹³ C ₁₂ -2,2',6,6'-TeCB	54L	2,2',3,6-TeCB	45	¹³ C ₁₂ -2,2',6,6'-TeCB	54L	2,3',4,4'-TeCB	66
¹³ C ₁₂ -2,2',6,6'-TeCB	54L	2,2',3,6'-TeCB	46	¹³ C ₁₂ -2,2',6,6'-TeCB	54L	2,3',4,5-TeCB	67
¹³ C ₁₂ -2,2',6,6'-TeCB	54L	2,2',4,4'-TeCB	47	¹³ C ₁₂ -2,2',6,6'-TeCB	54L	2,3',4,5'-TeCB	68
¹³ C ₁₂ -2,2',6,6'-TeCB	54L	2,2',4,5-TeCB	48	¹³ C ₁₂ -2,2',6,6'-TeCB	54L	2,3',4,6-TeCB	69
¹³ C ₁₂ -2,2',6,6'-TeCB	54L	2,2',4,5'-TeCB	49	¹³ C ₁₂ -2,2',6,6'-TeCB	54L	2,3',4',5-TeCB	70
¹³ C ₁₂ -2,2',6,6'-TeCB	54L	2,2',4,6-TeCB	50	¹³ C ₁₂ -2,2',6,6'-TeCB	54L	2,3',4',6-TeCB	71
¹³ C ₁₂ -2,2',6,6'-TeCB	54L	2,2',4,6'-TeCB	51	¹³ C ₁₂ -2,2',6,6'-TeCB	54L	2,3',5,5'-TeCB	72
¹³ C ₁₂ -2,2',6,6'-TeCB	54L	2,2',5,5'-TeCB	52	¹³ C ₁₂ -2,2',6,6'-TeCB	54L	2,3',5',6-TeCB	73
¹³ C ₁₂ -2,2',6,6'-TeCB	54L	2,2',5,6'-TeCB	53	¹³ C ₁₂ -2,2',6,6'-TeCB	54L	2,4,4',5-TeCB	74
¹³ C ₁₂ -2,2',6,6'-TeCB	54L	2,2',6,6'-TeCB	54	¹³ C ₁₂ -2,2',6,6'-TeCB	54L	2,4,4',6-TeCB	75
¹³ C ₁₂ -2,2',6,6'-TeCB	54L	2,3,3',4'-TeCB	55	¹³ C ₁₂ -2,2',6,6'-TeCB	54L	2',3,4,5-TeCB	76
¹³ C ₁₂ -2,2',6,6'-TeCB	54L	2,3,3',4'-TeCB	56	¹³ C ₁₂ -3,3',4,4'-TeCB	77L	3,3',4,4'-TeCB	77
¹³ C ₁₂ -2,2',6,6'-TeCB	54L	2,3,3',5-TeCB	57	¹³ C ₁₂ -3,3',4,4'-TeCB	77L	3,3',4,5-TeCB	78
¹³ C ₁₂ -2,2',6,6'-TeCB	54L	2,3,3',5'-TeCB	58	¹³ C ₁₂ -3,3',4,4'-TeCB	77L	3,3',4,5'-TeCB	79
¹³ C ₁₂ -2,2',6,6'-TeCB	54L	2,3,3',6-TeCB	59	¹³ C ₁₂ -3,3',4,4'-TeCB	77L	3,3',5,5'-TeCB	80
¹³ C ₁₂ -2,2',6,6'-TeCB	54L	2,3,4,4'-TeCB	60	¹³ C ₁₂ -3,4,4',5-TeCB	81L	3,4,4',5-TeCB	81
PeCB							
¹³ C ₁₂ -2,2',4,6,6'-PeCB	104L	2,2',3,3',4-PeCB	82	¹³ C ₁₂ -2,3,3',4,4'-PeCB	105L	2,3,3',4,4'-PeCB	105
¹³ C ₁₂ -2,2',4,6,6'-PeCB	104L	2,2',3,3',5-PeCB	83	¹³ C ₁₂ -2,3,3',4,4'-PeCB	105L	2,3,3',4,5-PeCB	106
¹³ C ₁₂ -2,2',4,6,6'-PeCB	104L	2,2',3,3',6-PeCB	84	¹³ C ₁₂ -2,3,3',4,4'-PeCB	105L	2,3,3',4',5-PeCB	107
¹³ C ₁₂ -2,2',4,6,6'-PeCB	104L	2,2',3,4,4'-PeCB	85	¹³ C ₁₂ -2,3,3',4,4'-PeCB	105L	2,3,3',4,5'-PeCB	108
¹³ C ₁₂ -2,2',4,6,6'-PeCB	104L	2,2',3,4,5-PeCB	86	¹³ C ₁₂ -2,3,3',4,4'-PeCB	105L	2,3,3',4,6-PeCB	109

Pre-extraction Standard	BZ ^b No.	Unlabeled Target Analyte	BZ ^b No.	Pre-extraction Standard	BZ ^b No.	Unlabeled Target Analyte	BZ ^b No.
¹³ C ₁₂ -2,2',4,6,6'-PeCB	104L	2,2',3,4,5'-PeCB	87	¹³ C ₁₂ -2,3,3',4,4'-PeCB	105L	2,3,3',4',6'-PeCB	110
¹³ C ₁₂ -2,2',4,6,6'-PeCB	104L	2,2',3,4,6'-PeCB	88	¹³ C ₁₂ -2,3,3',4,4'-PeCB	105L	2,3,3',5,5'-PeCB	111
¹³ C ₁₂ -2,2',4,6,6'-PeCB	104L	2,2',3,4,6'-PeCB	89	¹³ C ₁₂ -2,3,3',4,4'-PeCB	105L	2,3,3',5,6'-PeCB	112
¹³ C ₁₂ -2,2',4,6,6'-PeCB	104L	2,2',3,4',5'-PeCB	90	¹³ C ₁₂ -2,3,3',4,4'-PeCB	105L	2,3,3',5',6'-PeCB	113
¹³ C ₁₂ -2,2',4,6,6'-PeCB	104L	2,2',3,4',6'-PeCB	91	¹³ C ₁₂ -2,3,4,4',5'-PeCB	114L	2,3,4,4',5'-PeCB	114
¹³ C ₁₂ -2,2',4,6,6'-PeCB	104L	2,2',3,5,5'-PeCB	92	¹³ C ₁₂ -2,3,4,4',5'-PeCB	114L	2,3,4,4',6'-PeCB	115
¹³ C ₁₂ -2,2',4,6,6'-PeCB	104L	2,2',3,5,6'-PeCB	93	¹³ C ₁₂ -2,3,4,4',5'-PeCB	114L	2,3,4,5,6'-PeCB	116
¹³ C ₁₂ -2,2',4,6,6'-PeCB	104L	2,2',3,5,6'-PeCB	94	¹³ C ₁₂ -2,3,4,4',5'-PeCB	114L	2,3,4',5,6'-PeCB	117
¹³ C ₁₂ -2,2',4,6,6'-PeCB	104L	2,2',3,5',6'-PeCB	95	¹³ C ₁₂ -2,3',4,4',5'-PeCB	118L	2,3',4,4',5'-PeCB	118
¹³ C ₁₂ -2,2',4,6,6'-PeCB	104L	2,2',3,6,6'-PeCB	96	¹³ C ₁₂ -2,3',4,4',5'-PeCB	118L	2,3',4,4',6'-PeCB	119
¹³ C ₁₂ -2,2',4,6,6'-PeCB	104L	2,2',3',4,5'-PeCB	97	¹³ C ₁₂ -2,3',4,4',5'-PeCB	118L	2,3',4,5,5'-PeCB	120
¹³ C ₁₂ -2,2',4,6,6'-PeCB	104L	2,2',3',4,6'-PeCB	98	¹³ C ₁₂ -2,3',4,4',5'-PeCB	118L	2,3',4,5',6'-PeCB	121
¹³ C ₁₂ -2,2',4,6,6'-PeCB	104L	2,2',4,4',5'-PeCB	99	¹³ C ₁₂ -2,3',4,4',5'-PeCB	118L	2',3,3',4,5'-PeCB	122
¹³ C ₁₂ -2,2',4,6,6'-PeCB	104L	2,2',4,4',6'-PeCB	100	¹³ C ₁₂ -2',3,4,4',5'-PeCB	123L	2',3,4,4',5'-PeCB	123
¹³ C ₁₂ -2,2',4,6,6'-PeCB	104L	2,2',4,5,5'-PeCB	101	¹³ C ₁₂ -2',3,4,4',5'-PeCB	123L	2',3,4,5,5'-PeCB	124
¹³ C ₁₂ -2,2',4,6,6'-PeCB	104L	2,2',4,5,6'-PeCB	102	¹³ C ₁₂ -2',3,4,4',5'-PeCB	123L	2',3,4,5,6'-PeCB	125
¹³ C ₁₂ -2,2',4,6,6'-PeCB	104L	2,2',4,5',6'-PeCB	103	¹³ C ₁₂ -3,3',4,4',5'-PeCB	126L	3,3',4,4',5'-PeCB	126
¹³ C ₁₂ -2,2',4,6,6'-PeCB	104L	2,2',4,6,6'-PeCB	104	¹³ C ₁₂ -3,3',4,4',5'-PeCB	126L	3,3',4,5,5'-PeCB	127
HxCB							
¹³ C ₁₂ -2,2',4,4',6,6'-HxCB	155L	2,2',3,3',4,4'-HxCB	128	¹³ C ₁₂ -2,2',4,4',6,6'-HxCB	155L	2,2',3,4',5',6'-HxCB	149
¹³ C ₁₂ -2,2',4,4',6,6'-HxCB	155L	2,2',3,3',4,5'-HxCB	129	¹³ C ₁₂ -2,2',4,4',6,6'-HxCB	155L	2,2',3,4',6,6'-HxCB	150
¹³ C ₁₂ -2,2',4,4',6,6'-HxCB	155L	2,2',3,3',4,5'-HxCB	130	¹³ C ₁₂ -2,2',4,4',6,6'-HxCB	155L	2,2',3,5,5',6'-HxCB	151
¹³ C ₁₂ -2,2',4,4',6,6'-HxCB	155L	2,2',3,3',4,6'-HxCB	131	¹³ C ₁₂ -2,2',4,4',6,6'-HxCB	155L	2,2',3,5,6,6'-HxCB	152

Pre-extraction Standard	BZ ^b No.	Unlabeled Target Analyte	BZ ^b No.	Pre-extraction Standard	BZ ^b No.	Unlabeled Target Analyte	BZ ^b No.
¹³ C ₁₂ - 2,2',4,4',6,6'- HxCB	155L	2,2',3,3',4,6'- HxCB	132	¹³ C ₁₂ - 2,2',4,4',6,6'- HxCB	155L	2,2',4,4',5,5'- HxCB	153
¹³ C ₁₂ - 2,2',4,4',6,6'- HxCB	155L	2,2',3,3',5,5'- HxCB	133	¹³ C ₁₂ - 2,2',4,4',6,6'- HxCB	155L	2,2',4,4',5,6'- HxCB	154
¹³ C ₁₂ - 2,2',4,4',6,6'- HxCB	155L	2,2',3,3',5,6'- HxCB	134	¹³ C ₁₂ - 2,2',4,4',6,6'- HxCB	155L	2,2',4,4',6,6'- HxCB	155
¹³ C ₁₂ - 2,2',4,4',6,6'- HxCB	155L	2,2',3,3',5,6'- HxCB	135	¹³ C ₁₂ -2,3,3',4,4',5'- HxCB	156L	2,3,3',4,4',5'- HxCB	156
¹³ C ₁₂ - 2,2',4,4',6,6'- HxCB	155L	2,2',3,3',6,6'- HxCB	136	¹³ C ₁₂ - 2,3,3',4,4',5'- HxCB	157L	2,3,3',4,4',5'- HxCB	157
¹³ C ₁₂ - 2,2',4,4',6,6'- HxCB	155L	2,2',3,4,4',5'- HxCB	137	¹³ C ₁₂ - 2,3,3',4,4',5'- HxCB	157L	2,3,3',4,4',6'- HxCB	158
¹³ C ₁₂ - 2,2',4,4',6,6'- HxCB	155L	2,2',3,4,4',5'- HxCB	138	¹³ C ₁₂ - 2,3,3',4,4',5'- HxCB	157L	2,3,3',4,5,5'- HxCB	158
¹³ C ₁₂ - 2,2',4,4',6,6'- HxCB	155L	2,2',3,4,4',6'- HxCB	139	¹³ C ₁₂ - 2,3,3',4,4',5'- HxCB	157L	2,3,3',4,5,6'- HxCB	160
¹³ C ₁₂ - 2,2',4,4',6,6'- HxCB	155L	2,2',3,4,4',6'- HxCB	140	¹³ C ₁₂ - 2,3,3',4,4',5'- HxCB	157L	2,3,3',4,5,6'- HxCB	161
¹³ C ₁₂ - 2,2',4,4',6,6'- HxCB	155L	2,2',3,4,5,5'- HxCB	141	¹³ C ₁₂ - 2,3,3',4,4',5'- HxCB	157L	2,3,3',4,5,5'- HxCB	162
¹³ C ₁₂ - 2,2',4,4',6,6'- HxCB	155L	2,2',3,4,5,6'- HxCB	142	¹³ C ₁₂ - 2,3,3',4,4',5'- HxCB	157L	2,3,3',4,5,6'- HxCB	163
¹³ C ₁₂ - 2,2',4,4',6,6'- HxCB	155L	2,2',3,4,5,6'- HxCB	143	¹³ C ₁₂ - 2,3,3',4,4',5'- HxCB	157L	2,3,3',4,5',6'- HxCB	164
¹³ C ₁₂ - 2,2',4,4',6,6'- HxCB	155L	2,2',3,4,5',6'- HxCB	144	¹³ C ₁₂ - 2,3,3',4,4',5'- HxCB	157L	2,3,3',5,5',6'- HxCB	165
¹³ C ₁₂ - 2,2',4,4',6,6'- HxCB	155L	2,2',3,4,6,6'- HxCB	145	¹³ C ₁₂ - 2,3,3',4,4',5'- HxCB	157L	2,3,4,4',5,6'- HxCB	166
¹³ C ₁₂ - 2,2',4,4',6,6'- HxCB	155L	2,2',3,4',5,5'- HxCB	146	¹³ C ₁₂ - 2,3',4,4',5,5'- HxCB	167L	2,3',4,4',5,5'- HxCB	167
¹³ C ₁₂ - 2,2',4,4',6,6'- HxCB	155L	2,2',3,4',5,6'- HxCB	147	¹³ C ₁₂ - 2,3',4,4',5,5'- HxCB	167L	2,3',4,4',5',6'- HxCB	168
¹³ C ₁₂ - 2,2',4,4',6,6'- HxCB	155L	2,2',3,4',5,6'- HxCB	148	¹³ C ₁₂ - 3,3',4,4',5,5'- HxCB	169L	3,3',4,4',5,5'- HxCB	169
HpCB							

Pre-extraction Standard	BZ ^b No.	Unlabeled Target Analyte	BZ ^b No.	Pre-extraction Standard	BZ ^b No.	Unlabeled Target Analyte	BZ ^b No.
¹³ C ₁₂ - 2,2',3,4',5,6,6'- HpCB	188L	2,2',3,3',4,4',5- HpCB	170	¹³ C ₁₂ - 2,2',3,4',5,6,6'- HpCB	188L	2,2',3,4,4',5,6'- HpCB	182
¹³ C ₁₂ - 2,2',3,4',5,6,6'- HpCB	188L	2,2',3,3',4,4',6- HpCB	171	¹³ C ₁₂ - 2,2',3,4',5,6,6'- HpCB	188L	2,2',3,4,4',5',6- HpCB	183
¹³ C ₁₂ - 2,2',3,4',5,6,6'- HpCB	188L	2,2',3,3',4,5,5'- HpCB	172	¹³ C ₁₂ - 2,2',3,4',5,6,6'- HpCB	188L	2,2',3,4,4',5',6- HpCB	184
¹³ C ₁₂ - 2,2',3,4',5,6,6'- HpCB	188L	2,2',3,3',4,5,6- HpCB	173	¹³ C ₁₂ - 2,2',3,4',5,6,6'- HpCB	188L	2,2',3,4,4',6,6'- HpCB	185
¹³ C ₁₂ - 2,2',3,4',5,6,6'- HpCB	188L	2,2',3,3',4,5,6'- HpCB	174	¹³ C ₁₂ - 2,2',3,4',5,6,6'- HpCB	188L	2,2',3,4,5,5',6- HpCB	186
¹³ C ₁₂ - 2,2',3,4',5,6,6'- HpCB	188L	2,2',3,3',4,5',6- HpCB	175	¹³ C ₁₂ - 2,2',3,4',5,6,6'- HpCB	188L	2,2',3,4',5,5',6- HpCB	187
¹³ C ₁₂ - 2,2',3,4',5,6,6'- HpCB	188L	2,2',3,3',4,6,6'- HpCB	176	¹³ C ₁₂ - 2,2',3,4',5,6,6'- HpCB	188L	2,2',3,4',5,6,6'- HpCB	188
¹³ C ₁₂ - 2,2',3,4',5,6,6'- HpCB	188L	2,2',3,3',4',5,6- HpCB	177	¹³ C ₁₂ - 2,3,3',4,4',5,5'- HpCB	189L	2,3,3',4,4',5,5'- HpCB	189
¹³ C ₁₂ - 2,2',3,4',5,6,6'- HpCB	188L	2,2',3,3',5,5',6- HpCB	178	¹³ C ₁₂ - 2,3,3',4,4',5,5'- HpCB	189L	2,3,3',4,4',5,6- HpCB	190
¹³ C ₁₂ - 2,2',3,4',5,6,6'- HpCB	188L	2,2',3,3',5,6,6'- HpCB	179	¹³ C ₁₂ - 2,3,3',4,4',5,5'- HpCB	189L	2,3,3',4,4',5',6- HpCB	191
¹³ C ₁₂ - 2,2',3,4',5,6,6'- HpCB	188L	2,2',3,4,4',5,5'- HpCB	180	¹³ C ₁₂ - 2,3,3',4,4',5,5'- HpCB	189L	2,3,3',4,5,5',6- HpCB	192
¹³ C ₁₂ - 2,2',3,4',5,6,6'- HpCB	188L	2,2',3,4,4',5,6- HpCB	181	¹³ C ₁₂ - 2,3,3',4,4',5,5'- HpCB	189L	2,3,3',4',5,5',6- HpCB	193
OcCB				NoCB			
¹³ C ₁₂ - 2,2',3,3',5,5',6,6'- -OcCB	202L	2,2',3,3',4,4',5,5'- -OcCB	194	¹³ C ₁₂ - 2,2',3,3',4,4',5,5',6 -NoCB	206L	2,2',3,3',4,4',5, 5',6-NoCB	206
¹³ C ₁₂ - 2,2',3,3',5,5',6,6'- -OcCB	202L	2,2',3,3',4,4',5,6 -OcCB	195	¹³ C ₁₂ - 2,2',3,3',4,4',5,5',6 -NoCB	206L	2,2',3,3',4,4',5, 6,6'-NoCB	207
¹³ C ₁₂ - 2,2',3,3',5,5',6,6'- -OcCB	202L	2,2',3,3',4,4',5,6' -OcCB	196	¹³ C ₁₂ - 2,2',3,3',4,4',5,5',6,6' -NoCB	208L	2,2',3,3',4,5,5', 6,6'- NoCB	208
¹³ C ₁₂ - 2,2',3,3',5,5',6,6'- -OcCB	202L	2,2',3,3',4,4',6,6' -OcCB	197	DeCB			
¹³ C ₁₂ - 2,2',3,3',5,5',6,6'- -OcCB	202L	2,2',3,3',4,5,5',6 -OcCB	198	¹³ C ₁₂ -DeCB	209L	2,2',3,3',4,4',5, 5',6,6'-DeCB	209

Pre-extraction Standard	BZ ^b No.	Unlabeled Target Analyte	BZ ^b No.	Pre-extraction Standard	BZ ^b No.	Unlabeled Target Analyte	BZ ^b No.
¹³ C ₁₂ - 2,2',3,3',5,5',6,6' -OcCB	202L	2,2',3,3',4,5,5',6' -OcCB	199				
¹³ C ₁₂ - 2,2',3,3',5,5',6,6' -OcCB	202L	2,2',3,3',4,5,6,6' -OcCB	200				
¹³ C ₁₂ - 2,2',3,3',5,5',6,6' -OcCB	202L	2,2',3,3',4,5',6,6' -OcCB	201				
¹³ C ₁₂ - 2,2',3,3',5,5',6,6' -OcCB	202L	2,2',3,3',5,5',6,6' -OcCB	202				
¹³ C ₁₂ - 2,3',3',4,4',5,5',6 -OcCB	205L	2,2',3,4,4',5,5',6 -OcCB	203				
¹³ C ₁₂ - 2,3',3',4,4',5,5',6 -OcCB	205L	2,2',3,4,4',5,6,6' -OcCB	204				
¹³ C ₁₂ - 2,3',3',4,4',5,5',6 -OcCB	205L	2,3,3',4,4',5,5',6 -OcCB	205				

^a Assignments assume the use of the SPB-Octyl column. In the event you choose another column, you may select the labeled standard having the same number of chlorine substituents and the closest retention time to the target analyte in question as the labeled standard to use for quantitation.

^bBZ No.: Ballschmiter and Zell 1980, also referred to as IUPAC number.

Appendix B

Preparation of XAD-2 Adsorbent Resin

1.0 Scope and Application

XAD-2[®] resin, as supplied by the original manufacturer, is impregnated with a bicarbonate solution to inhibit microbial growth during storage. Remove both the salt solution and any residual extractable chemicals used in the polymerization process before use. Prepare the resin by a series of water and organic extractions, followed by careful drying.

2.0 Extraction

2.1 You may perform the extraction using a Soxhlet extractor or other apparatus that generates resin meeting the requirements in Section 9.2.6.3 of this method. Use an all-glass thimble containing an extra-coarse frit for extraction of the resin. The frit is recessed 10-15 mm above a crenellated ring at the bottom of the thimble to facilitate drainage. Because the resin floats on methylene chloride, carefully retain the resin in the extractor cup with a glass wool plug and stainless-steel screen. This process involves sequential extraction with the following recommended solvents in the listed order.

- Water initial rinse: Place resin in a suitable container, soak for approximately 5 min with Type II water, remove fine floating resin particles and discard the water. Fill with Type II water a second time, let stand overnight, remove fine floating resin particles and discard the water.
- Hot water: Extract with water for 8 hr.
- Methyl alcohol: Extract for 22 hr.
- Methylene chloride: Extract for 22 hr.
- Toluene: Extract for 22 hr.

- Methylene chloride: Extract for 22 hr.

Note: You may store the resin in a sealed glass container filled with toluene prior to the final toluene extraction. It may be necessary to repeat the final toluene extractions to meet the requirements in Section 9.2.6.3 of this method.

2.2 You may use alternative extraction procedures to clean large batches of resin. Any size extractor may be constructed; the choice depends on the needs of the sampling programs. The resin is held in a glass or stainless-steel cylinder between a pair of coarse and fine screens. Spacers placed under the bottom screen allow for even distribution of clean solvent. Clean solvent is circulated through the resin for extraction. A flow rate is maintained upward through the resin to allow maximum solvent contact and prevent channeling.

2.2.1 Experience has shown that 1 mL/g of resin extracted is the minimum necessary to extract and clean the resin. The aqueous rinse is critical to the subsequent organic rinses and may be accomplished by simply flushing the canister with about 1 liter of distilled water for every 25 g of resin. A small pump may be useful for pumping the water through the canister. You should perform the water extraction at the rate of about 20 to 40 mL/min.

2.2.2 All materials of construction are glass, PTFE, or stainless steel. Pumps, if used, should not contain extractable materials.

3.0 Drying

3.1 Dry the adsorbent of extraction solvent before use. This section provides a recommended procedure to dry adsorbent that is wet with solvent. However, you may use other procedures if the cleanliness requirements in Section 9.2.6.3 of this method are met.

3.2 Drying Column. A simple column with suitable retainers will hold all the XAD-2 from the extractor or the Soxhlet extractor, as shown in Figure B-1, with sufficient space for drying the bed while generating a minimum backpressure in the column.

3.3 Drying Procedure: Dry the adsorbent using clean inert gas. Liquid nitrogen from a standard commercial liquid nitrogen cylinder has proven to be a reliable source of large volumes of gas free from organic contaminants. You may use high-purity tank nitrogen to dry the resin. However, you should pass the high-purity nitrogen through a bed of activated charcoal approximately 150 mL in volume prior to entering the drying apparatus.

3.3.1 Connect the gas vent of a liquid nitrogen cylinder or the exit of the activated carbon scrubber to the column by a length of precleaned copper tubing (e.g., 0.95 cm ID) coiled to pass through a heat source. A convenient heat source is a water bath heated from a steam line. The final nitrogen temperature should only be warm to the touch and not over 40 °C.

3.3.2 Allow the methylene chloride to drain from the resin prior to placing the resin in the drying apparatus.

3.3.3 Flow nitrogen through the drying apparatus at a rate that does not fluidize or agitate the resin. Continue the nitrogen flow until the residual solvent is removed.

Note: Experience has shown that about 500 g of resin may be dried overnight by consuming a full 160-L cylinder of liquid nitrogen.

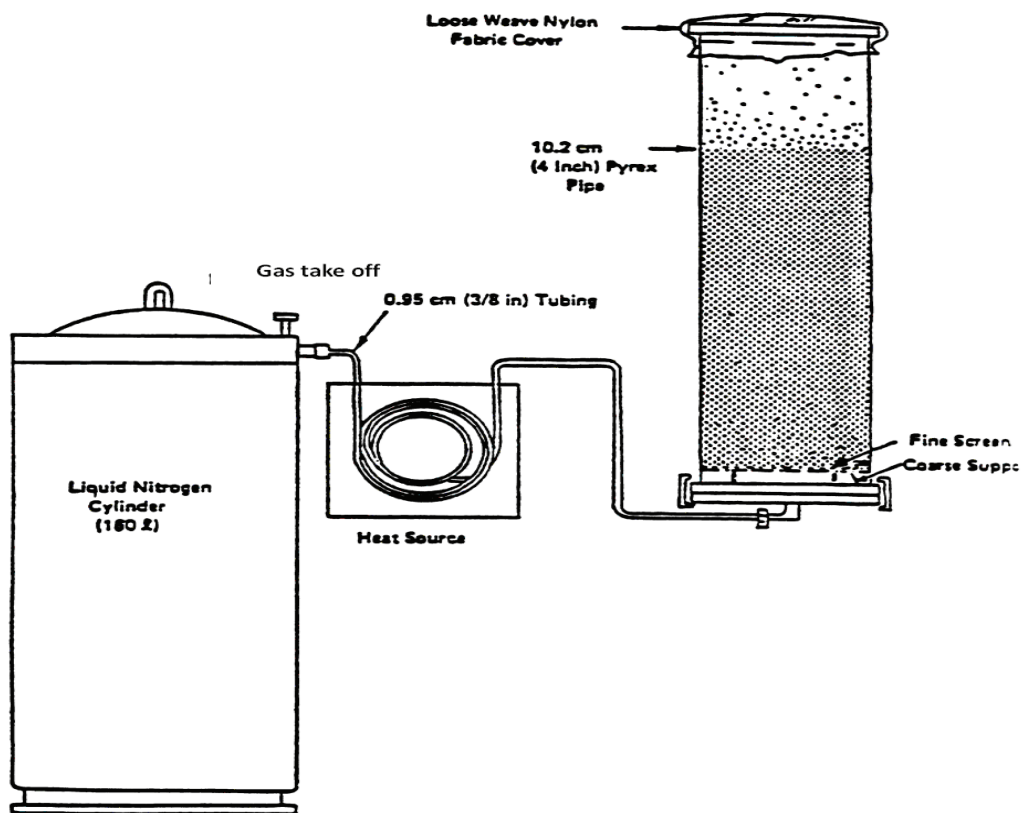

Figure B-1. XAD-2 fluidized-bed drying apparatus