

# Water Management Guide

---

# **ACKNOWLEDGMENTS**

The United States General Services Administration would like to acknowledge the following people that have contributed to the development, review and printing of this guidebook:

From the General Services Administration and its facilities:

Mark Ewing, GSA Energy Center of Expertise

From Enviro-Management & Research, Inc.:

Naresh Khosla, Technical Review

Chuck Tobler, Technical Research, Writing and Editing

Jayoung Choi, Graphic Design

# OVERVIEW

Welcome to *Water Management: A Comprehensive Approach for Facilities Managers*. This handbook explains the new water-conservation requirements under Executive Order (EO 13123), "Greening the Government Through Efficient Energy Management," signed by President Clinton on June 3, 1999. It also provides comprehensive guidance on how to meet these requirements, from detailed descriptions of water-conserving technologies and principles to how to measure water use and develop a water management plan to economic analysis and innovative financing options. In short, this guidebook will help you, the Federal facilities manager, meet all mandated water-conservation requirements and help preserve what many are calling *the* commodity of the next century: fresh, potable water.

## Water Conservation: It's the Law

Thanks to the efforts of Federal facilities managers, significant progress has been made toward reducing the energy and water consumption in Federal facilities. On the energy side, the overall real cost of energy consumption in the Federal Government has fallen from \$14.6 billion in 1985 to \$7.7 billion in 1996, and total net energy consumption in 1996 decreased 23.4% from 1985. On the water front, while concrete figures on Federal water use over the past several years are difficult to obtain, in general, water use in the United States has declined since 1990.

---

*Executive Order  
13123 requires  
Federal facilities to  
assess their water  
use, examine  
available and  
appropriate water-  
conservation  
products, and retrofit  
or replace existing  
equipment to make it  
more efficient.  
The water  
conservation goals  
will be set by June  
2000.*

---

But there is still much to be done to meet the goals of Executive Order 13123, "Greening the Government Through Efficient Energy Management," which mandates that Federal agencies, by 2010, reduce their energy use by 35% compared to energy use in 1985. The new mandated water-conservation goals, though not yet determined, will be set by the Secretary of Energy no later than June 3, 2000, and will likely be more stringent than the current goals. This Executive Order, along with other related executive orders and the Energy Policy Act of 1992, require Federal facilities to initiate comprehensive water conservation programs within their own facilities. Federal facilities must assess their water use, examine available and appropriate water conservation products, and retrofit or replace existing equipment to make it more efficient.

This guidebook will help Federal facility managers meet these goals by providing an overview of the principles of water management; specific steps on developing, implementing, and monitoring a water management plan (as well as a brief primer on developing a drought management plan); descriptions of water management technologies; and a list of useful financial and technical resources.

---

*This handbook will help you, the Federal facilities manager, preserve what many are calling the commodity of the next century: fresh, potable water*

---

## Features of this Book

The chapters of this guidebook, when followed sequentially, are designed to help facility managers develop an overall water management plan tailored to a specific facility. The chapters are outlined briefly below:

Chapter 1 explains the benefits of water management and includes a comprehensive overview of the new Executive Order, "Greening the Government Through Efficient Energy Management," and what it requires of you, the Federal facilities manager. It also provides an overview of federal facility energy and water use.

Chapter 2 explains the general principles of water management, including three major water-conserving areas and building and use characteristics that affect water consumption.

Chapter 3 outlines the steps in developing a water management plan.

Chapter 4 provides a brief primer on developing a drought management plan and water-reduction measures that can be implemented during periods of drought.

Chapter 5 details the wide variety of water-conserving technologies that are available to the Federal facilities manager. These technologies are grouped into three general categories: plumbing products, heating and cooling products, and landscaping/irrigation products.

Chapter 6 covers onsite wastewater recycling, reclaimed water, and rainwater harvesting.

Chapter 7 provides useful information on financing options, a description of the Federal Energy Management Program, a listing of valuable Internet resources, a description of energy-savings performance contracts, and tips on selecting a contractor.

Finally, the appendices supplement the steps to a water management plan with sample energy survey worksheets, discuss selected regulations affecting conservation programs, and provide a glossary of terms relating to water efficiency programs.

Although this guidebook directly addresses water management, it indirectly addresses energy consumption as well: Using less water saves the electricity needed to heat, cool, treat, or move water, thereby cutting energy use and reducing harmful emissions from the burning of fossil fuels.

---

*Conserving water  
saves energy as well,  
and helps reduce  
greenhouse gas  
emissions*

---

# TABLE OF CONTENTS

<b>Overview</b> .....	v
<b>Chapter 1—Why Water Management? Benefits and Legislative Requirements</b> .....	1
<b>Chapter 2—Principles of Water Management</b> .....	9
<b>Chapter 3—Developing a Water Management Plan</b> .....	13
<b>Chapter 4—Drought Management</b> .....	35
<b>Chapter 5—Water-Conserving Technologies</b> .....	41
Plumbing Products .....	45
Heating, Ventilating, and Air-Conditioning Equipment .....	71
Landscape Irrigation .....	79
<b>Chapter 6—On-site Wastewater Recycling/Reclaimed Water</b>	89
<b>Chapter 7—Your Water Management Toolkit: Financial and Technical Resources</b> .....	104
<b>Glossary</b> .....	Glossary-1
<b>References</b> .....	References-1
<b>Appendix A—Federal, State, and Community Water Consumption Standards</b> .....	A-1
<b>Appendix B—Worksheets</b> .....	B-1
<b>Appendix C—Sample Letter to Building Occupants</b> .....	C-1

# 1

## WHY WATER MANAGEMENT? BENEFITS AND LEGISLATIVE REQUIREMENTS

According to the Federal Energy Management Program (FEMP), the Federal sector spends between \$0.5 billion and \$1 billion annually on water and sewer services. FEMP also estimates that the Federal Government could save as much as \$240 million by installing water-conservation measures. And these savings will only increase as the cost of water and related water-treatment services continue to rise: rates have risen 100% to 400% in the past 10 years in major cities, and this trend is expected to continue.

The Federal government either owns, leases, manages, maintains, or operates more than 500,000 buildings across the country—buildings that uses between 300 and 450 million gallons of water a day. Annually, that's roughly half the volume of Lake Ontario. So Federal facilities managers' contributions to conserving the Nation's pre-

---

*Federal facilities managers play a major role in conserving the Nation's precious water resources*

---

### Federal Water Use at a Glance

- Federal water use is between 300 and 450 million gallons a day
- Federal water use accounts for 3% of all U.S. commercial water use
- GSA estimates that water and sewer costs rose 32% from 1993-1995
- The major Federal water users are the Army, Air Force, Navy, and the Veterans Administration
- Federal water conservation potential is estimated at 121 million gallons per day—the approximate water use of 1.8 million people

cious water resources are critical. For GSA, which manages or owns more than 7,700 facilities, the savings potential is equally impressive.

Following are just some of the reasons for water management at Federal facilities:

- A well-planned water-management program can reduce water and sewer costs by 30% or more, with no cutbacks in operations or service levels.
- The purchasing decisions of Federal facilities managers greatly affect the types of products produced by manufacturers—in short, the Federal government acts as an important “technology push” for more efficient products and technologies.
- Water conservation at Federal facilities is required by law (these laws are detailed in the next section of this chapter).

---

*The EPACT water-efficiency standards will save 6.5 billion gallons of water each day by the year 2025.*

---

## **Legislative and Executive Requirements for Water Conservation**

Water conservation at Federal facilities is required by several laws. The major laws are described below.

### **Executive Order 13123, "Greening the Government through Efficient Energy Management"**

On June 3, 1999, President Clinton signed Executive Order 13123, “Greening the Government Through Efficient Energy Management,” which states:

“The Federal Government, as the Nation’s largest energy consumer, shall significantly improve its energy management in order to save taxpayer dollars and reduce emissions that contribute to air pollution and global climate change. . . . As a major consumer that spends \$200 billion annually on products and services, the Federal Government can promote energy efficiency, water conservation, and the use of renewable energy products, and help foster markets for emerging technologies. In encouraging effective energy management in the Federal Government, this order builds on work begun under EPACT and previous Executive orders.”

This order, which builds on (and revokes) Executive Orders 12759 (“Federal Energy Management”), 12902 (“Energy Efficiency and Water Conservation at Federal Facilities”), and 12845 (“Procurement Requirements and Policies for Federal Agencies for



Ozone-Depleting Substances”), applies to all Federal departments and agencies. The order requires that agencies reduce their energy consumption by 30% by 2005 and 35% by 2010, relative to 1985. The order also requires Federal agencies to reduce their water consumption (though note that the mandated water reductions have not yet been determined).

The order requires that agencies use life-cycle cost analysis when making decisions about investments in energy- and water-conservation products, services, construction, and other projects. Agencies that minimize life-cycle costs with efficiency measures will be recognized on their scorecard evaluations. The order also requires agencies to maximize their use of energy-savings performance contracts and utility energy-efficiency service contracts, when they are life-cycle cost-effective.

#### **Water-Conservation Requirements Under the Order**

The order requires the following acts specifically related to water conservation:

- Each agency must reduce its water consumption and associated energy use in its facilities to reach the water-conservation goals set by the Secretary of Energy. As part of this requirement, agencies must establish a reliable baseline of water use.
- The General Services Administration must work with agencies to meet the requirements of the order for those facilities for which GSA has delegated operations and maintenance authority.
- Each agency must develop an annual implementation plan for fulfilling the requirements of the order.
- Where possible, water cost savings shall be included in energy savings performance contracts (these contracts are discussed in Chapter 7).
- Agencies shall continue to conduct energy and water audits for approximately 10% of their facilities each year.
- GSA and the Department of Defense, in consultation with DOE and EPA, shall develop sustainable design principles.

---

*Agencies must use  
life-cycle cost  
analysis when making  
decisions about  
investments in  
energy- and water-  
conservation*

---

### **Technical/Programmatic Assistance Provided by the Order**

The order requires that the following guidance/assistance be provided to help Federal facilities managers reach the energy- and water-efficiency goals: (See [www.eren.doe.gov/femp/aboutfemp.html](http://www.eren.doe.gov/femp/aboutfemp.html))

---

*Executive Order 13123 provides a wide range of assistance to help facility managers meet the required water- and energy-efficiency goals.*

---

- Guidance to help each agency determine a baseline of water consumption.
- Water conservation goals for Federal agencies. These goals are based on implementation of Best Management Practices (BMPs). Details can be found at the FEMP website listed above.
- The Federal Energy Management Program (FEMP) will work with agencies to ensure they meet the goals of the order, and shall develop and issue guidelines to help agencies prepare their annual reports.
- FEMP will have primary responsibility for collecting and analyzing the data contained in the annual reports.

### **Financial Assistance/Incentives**

- The order states: "OMB [Office of Management and Budget] shall explore the feasibility of establishing a fund that agencies could draw on to finance exemplary energy management activities and investments with higher initial costs but lower life cycle costs."
- OMB shall issue guidelines to help agencies develop appropriate budget requests that support sound investments in energy improvements.
- Agencies that have been granted statutory authority to retain a portion of savings from efficient energy and water management are encouraged to allow these savings to be retained at the facility or site where the savings were generated, to provide incentives for that facility to undertake more energy and water management initiatives.

### **EPACT (Energy Policy Act)**

In 1992 Congress passed the Energy Policy Act (EPACT). EPACT set minimum efficiency standards for water-using devices such as toilets, urinals, faucets and showerheads. The American Water Works Association estimates that these standards will save 6.5 billion gallons of water each day by the year

2025. EPACT also requires each government agency to install in Federal buildings all energy and water conservation measures with payback periods of less than 10 years. Further, EPACT also requires GSA to begin a program to purchase energy efficient products.

## Benefits of Water Management

Historically, clean water has been regarded as an inexhaustible and inexpensive resource. However, recent events, such as the severe 1999 drought in the Northeastern United States, emphasized that water is not something to be taken for granted: It is better to use what we have more efficiently than to seek out new sources of supply or build more wastewater facilities. In fact, some analysts are calling fresh, potable water *the* commodity of the next century, and there is concern in some circles of Eastern "water wars," similar to those in the West.

Wise use of this precious resource ensures that clean water supplies will be available for future generations. Also, by reducing our water consumption, we in turn reduce the energy needed to treat, heat, and cool water. Less energy required means fewer emissions from powerplants and greater pollution prevention, which are also major goals of Executive Order 13123.

And saving water does not have to require large capital- or time-outlays: Seemingly small water management improvements can also lead to significant dollar savings. For example, just fixing a leaking faucet can save 36 gallons of water per day. Replacing that same faucet with an auto-

---

*Saving water does not have to require large capital- or time-outlays: just fixing a leaking faucet can save 36 gallons of water per day.*

---

### The Quiet Leaker

According to utilities, leaks can easily account for 10 percent of a water bill—and waste not only water but also energy if the source is a hot water tap or boiler. While some leaks are obvious, such as faucet leaks, others are somewhat hidden, such as "silent leaks" from tank-type toilets. A silent leak occurs when water leaks from the tank into the bowl. To test for a silent leak, place a few drops of food coloring in the water in the toilet tank, after the water has stopped running and the tank is full. Wait 10 minutes. DO NOT FLUSH THE TOILET. If the dye appears in the toilet bowl, you have a silent leak. Silent leaks can often be fixed by replacing the flush valve flapper ball (under \$3) or by cleaning or replacing the valve seat. Source: Federal Energy Management Program.

matic-shutoff control that delivers a limited flow of water for a limited time can save about 5,000 gallons of water and reduce a water bill by roughly \$50 per year. Savings dramatically multiply when they are expanded beyond a single building. For example, the Boston metropolitan area reduced its water use by 16 percent through a comprehensive retrofit, water audit, leak detection, and education program.<sup>1</sup>

## Federal Facility Water Consumption

Because water management in Federal facilities has not received the same attention afforded energy management, very little information is available on water use and demand in Federal facilities. Even at GSA, the number and variety of buildings complicate any effort to track water use. Further, leases themselves often obscure water consumption data. A 1992 Federal building review by the Environmental and Energy Study Institute found that many Federal facilities have their water bill paid as part of their lease. So in many instances, there is simply no separate water bill that shows water consumption.

For example, GSA currently directly pays utility bills in facilities covering about 258 million square feet of space. These facilities include office buildings, courthouses, post offices, warehouses, border stations, and other buildings nationwide (Figure 1-2). Of these, the greatest water consumption occurs in Federal office buildings, followed by Federal courthouses, the two building types that comprise the majority of all GSA facilities.

However, while no comprehensive database exists to track water use in many Federal facilities, the Public Buildings Service, a branch of GSA, does maintain records from GSA facilities that submit their water bills directly to regional offices for payment. These regional records, in turn, suggest important water-use trends in GSA facilities. Some of these trends are highlighted in the following section.

---

<sup>1</sup>Levy, P.F., and W.A. Brutsch. *MIRA Long Range Water Supply Program*. (Boston, Mass.: Massachusetts Water Resources Authority, 1990).

<sup>2</sup>Arnold, M.L. and D. Gray. *Water Efficiency in Federal Facilities and Programs*. (Washington, D.C.: Environmental and Energy Study Institute, 1993).

### GSA Water Consumption

A look at GSA regional water use for FY1999 reveals the following:

The average regional facility for which water data was collected, contains 679,318 square feet and has an average occupancy of 1850 people. Among these facilities, the average monthly consumption per facility was 1,146,816 gallons.

Existing data for all GSA occupancy and uses are limited in that visitors, who have both direct and indirect impacts on total water consumption, are difficult to account for.

Because no comprehensive information on water use in GSA facilities exists, it is difficult to determine the quantities of water used for different applications. However, looking at similar plumbing product use in commercial buildings gives an idea as to what the breakdown might be (Figure 1-1). An understanding of how characteristics such as physical features, occupancy and use, and climate and geography affect water use further helps to round out the profile of GSA water consumption.

**Figure 1-1. Water Use in Commercial Buildings.**

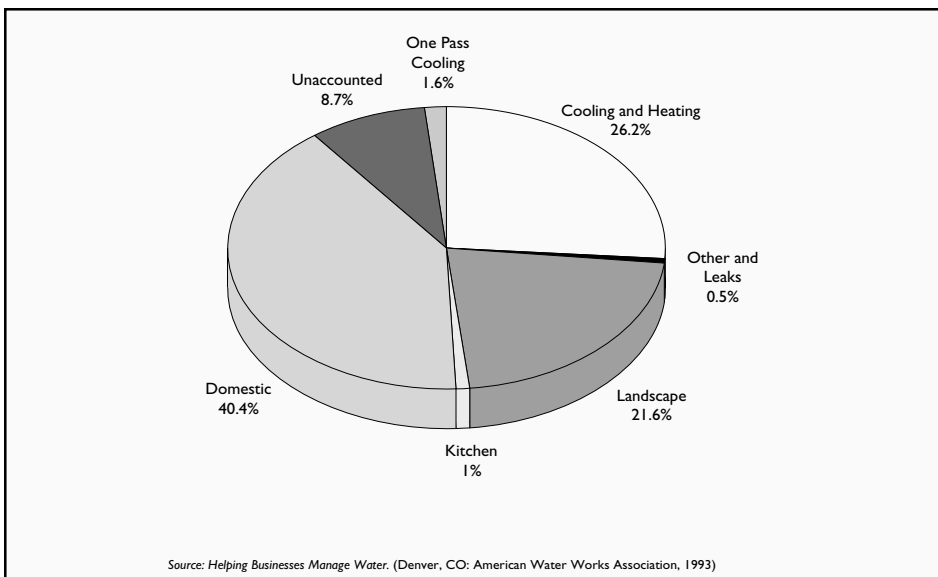

# 2

## PRINCIPLES OF WATER MANAGEMENT

Developing a water management plan is logical and follows an established sequence of events. Water management, however, is more than just conducting a cost-benefit analysis and preparing a report. Successful water management benefits from a holistic approach, one that not only considers the technical side, such as installing efficient fixtures and making operation and maintenance modifications, but also the human side, such as changing longstanding behaviors and expectations. It also requires that facility managers look at managing water use so that they comply with the law, make cost-effective decisions, and can document their environmental savings.

The following general guidelines will help you develop a comprehensive, effective water management program:

- Water management techniques fall into three general areas: first, reducing losses (for example, leak detection); second, reducing the overall amount of water used (for example, using low-flush toilets and automatic shut-off faucets); and third, reusing water that would otherwise be discarded (for example, treating water from sinks and toilets for use on landscaped areas).
- The main water-using areas in a building are plumbing fixtures (toilets, faucets, showers, dishwashers, clotheswashers, and so forth); landscaping (irrigation, fountains, and so forth); and heating, ventilating, and air-conditioning equipment (cooling towers, chillers, air-conditioners, and so forth).

---

*Water management techniques fall into three general areas: reducing losses, reducing the overall amount of water used, and reusing water that would otherwise be discarded*

---

- Water use does not exist in a vacuum. Conserving water within a building also affects other building systems. For example, reducing the amount of hot water used in a dishwasher would also reduce the amount of energy needed to heat that water.
- The true and total cost of water is not just the amount on the water bill, but also includes the cost to heat, cool, treat, and pump it to where it is needed. It also includes wastewater treatment.
- An effective plan is one that fully outlines not just how much water is used, but how it is used and by whom.
- The plan should address both the supply side and the demand side—in other words, do not just focus on building occupants; also work with your water utility.
- Your water management plan, to a large degree, will only be as good as the data you collect in order to develop it.
- Implementation should be done in phases, starting with obvious, low-cost options.
- Keep in mind that state regulations are sometimes more stringent than Federal regulations.
- Options should be evaluated based on life-cycle costing, not just by considering the initial investment.
- The building's management must be committed to water management if they want to convince occupants that their actions make a positive difference.

---

*Tip: Often  
a  
building's  
use, rather  
than size  
or  
occupancy,*

## **Factors Affecting a Building's Water Consumption**

### **Building Design**

Water use is greatly affected by the type of building, its characteristics, and the type of site on which it is located. The water demand of a warehouse, for example, is markedly different from that of an office building.

Building design is a key determinant of both energy and water consumption. The building's envelope or shell (walls,

ceilings, and floors), heating, ventilating, and air-conditioning systems, and lighting design determine indoor humidity and comfort, all of which have a direct and indirect impact on water use. Likewise, the number and conservation potential of water fixtures (for example, toilets, urinals, faucets, and showers) have a direct effect on water use, as does the building's amount of landscaped area.

### **Building Size versus Use**

The size of a building, measured either in gross square footage or occupiable square footage, is not always a reliable predictor of water consumption. In many cases, occupancy and use are better predictors of water consumption. Warehouses and office buildings of the same square footage generally have different designs, occupancy, and functions, all of which lead to differences in water consumption. According to GSA, for example, the average GSA warehouse consumes only one-third the water of the average office building but contains more than 2.5 times the floor space. This is because a greater percentage of space in the warehouse is used solely for storage—meaning that there is less space that needs to be conditioned and fewer people in the building to use water.

### **Climate and Geography**

Climate and geography have major effects on water use, from stimulating the need for air-conditioning in the summer and requiring heat in the winter to determining how drought-resistant shrubs and turf may be used for landscaping the building grounds. For new construction, to maximize water efficiency, facility architects should consider geography when planning a building's design and landscaping. All other factors being equal, the warmer or more arid the climate and geography, the greater the water use.

### **The Human Touch**

The importance of employee participation in your water-conservation efforts cannot be overemphasized: The best technologies in the world won't work unless people use them, and use them correctly. Let people know that their efforts are helping to save water, and which technologies are being used, and why. Communicate successes. And remember: Some of the simplest ways to save water don't require any technology at all, but rather a change in longstanding behavior (for

---

*The average GSA warehouse consumes only one-third the water of the average office building but contains more than 2.5 times the floor space.*

---



---

*Employee participation in your water-conservation program is critical*

---



# 3

## DEVELOPING A WATER MANAGEMENT PLAN

A successful water management program begins with the development of a comprehensive water management plan. This plan depends on a clear and complete understanding of how a facility uses water, from the time it is piped into the building to its ultimate disposal or reuse.

Given that water use can vary greatly from one Federal facility to another, each facility should be surveyed to identify its water consumption characteristics. The facility survey helps you to determine the total cost of your building's current water use. Knowing how you currently use water and what it costs enables you to make the most appropriate water management decisions.

This chapter details the steps involved in developing a successful water management plan. They are as follows:

- Step 1: Determine your baseline water use.
- Step 2: Explore and evaluate water management options

---

*A successful water management program depends on a clear and complete understanding of how a facility uses water, and the total cost of that water*

---

### Elements of a Successful Water Management Plan

A successful water management plan must:

- determine your baseline water use
- prioritize needs
- effectively use life-cycle cost analysis
- set well-informed goals
- establish performance minimums
- chart a course of action

- Step 3: Conduct life-cycle cost analyses and explore financing options
- Step 4: Develop a water management plan and a work schedule
- Step 5: Inform building occupants about water management
- Step 6: Implement the water management plan
- Step 7: Monitor the water management program

### **Step 1: Determine Your Baseline Water Use**

---

*The people who are familiar with daily facility operations can be very helpful when you are gathering information*

---

Baseline water information will be used to describe total estimated Federal water usage and monitor the impact of future water efficiency improvements. Available data may be incomplete, so an important component of this process will be to assess the existing data, determine an estimation process, and ultimately to collect more complete data on water use at Federal facilities.

Agencies shall establish baseline potable water usage at facilities owned by the United States government. As established in guidance issued by DOE in accordance with E.O. 13123, the baseline year is defined as FY00 (October 1, 1999 through September 30, 2000). Data shall be reported in Million Gallons per Year (MGY). Agencies should use actual data where available, or make a best estimate where actual data are not available.

#### **Facilities Where Actual Data Are Available**

Agencies should use data from one or more of the following sources: facility meter(s), the local water/wastewater supplier(s) and/or metered well(s). If multiple data sources are used, care should be taken to not "double count." But remember: the more detailed and accurate your baseline water-use data, the more effective and comprehensive your water-management plan will be. For a step-by-step explanation on how to conduct a detailed water-use survey, see "Conducting a Comprehensive Water-Use Survey" below.

---

Pike, C<sup>2</sup>W., et al., *Water Efficiency Guide for Business Managers and Facility Engineers* (CA: The Resources Agency, State of California, 1993), p. 24, 25; *A.S.S.E. Water and Conservation Guidelines*, (Cleveland, OH: American Society of Sanitary Engineering, 1987).

### Facilities Where Actual Data Are Not Available

Agencies with facilities where no actual water usage information is available should estimate water usage. If a facility has had a recent water use survey, agencies can use those results to estimate water use. Otherwise, to achieve a reasonable estimate, agencies should, at a minimum:

1. Identify the significant factors which determine water usage, such as number of beds in a hospital, number of prisoners, number of employees and visitors, production units and /or irrigated acreage (this step is detailed below);
- 2 Determine the numeric value for those factors (see the tables in Chapter 7);
- 3 Then, multiply the numeric value by water use indices to be provided by the Federal Energy Management Program. FEMP will provide water use indices for hospital beds, prisoners, employees, dwelling units, and schools. Agencies with other significant or unusual water usage should contact FEMP for assistance.

---

*The more  
comprehensive the  
survey, the greater  
the value of the  
resulting water  
management options  
and cost savings*

---

### Identifying Significant Water-Use Factors

Before starting a water use survey, collect as much existing information as possible. The people who are familiar with daily facility operations, especially operating and maintenance personnel, can be very helpful in this step. Some information will be readily available, while other data will take some time to collect. Specifically, gather the following:

- Building floorplan and plumbing drawings and schematics.
- Typical facility operating schedules, number of employees and visitors, and maintenance and janitorial work schedules.
- Lists of all water-using equipment with the manufacturers' rated flowrates.
- Number of plumbing fixtures (toilets, urinals, and so forth).
- Outdoor water use applications, quantity, and schedule.
- Any prior water and energy surveys.
- Names of energy, water, and wastewater utilities.
- Water and sewer bills for the past 2 years.

### Sample Water Survey Results

*The objective of a water survey is to investigate the condition of current plumbing fixtures and to develop recommendations for water management measures that could be implemented without adversely impacting the safety, comfort, or productivity of building tenants.*

This survey was performed at the four-story Van Nuys Federal Building and Post Office, which houses about 959 employees and is located at 6230 Van Nuys Blvd. in Van Nuys, California. It revealed that most of the plumbing equipment is the original equipment installed when the building was first constructed in 1974. Specific results of the audit are as follows:

- Fifty-nine 4.5-gallon-per-flush (gpf) toilets in the men's and women's restrooms can be replaced with 1.6-gpf toilets, saving approximately 3,216 gallons per day (assuming 670 people use the toilets twice a day).
- Fourteen 3-gpf urinals in the men's rooms can be replaced with 1-gpf urinals, saving approximately 1,160 gallons per day (assuming 290 people use the urinals twice a day).
- Forty-six 2-gallon-per-minute (gpm) faucets can be retrofitted with 0.5-gpm aerators, saving approximately 1,598 gallons per day (assuming 959 employees use the faucets twice a day at an average flow period of 25 seconds).
- Angle stops, supplies, and grid drains on the faucets can be replaced to cut down on maintenance costs and prevent leaks.
- Battery-operated flushing controls can be added to flush toilets automatically when the seat cover is lowered.
- Existing cooling tower performance can be improved.

The Building Life-Cycle Cost Analysis 4.0 computer software was used to perform a comparative economic analysis of the project. The results from this analysis are as follows:

- Simple payback and discounted payback occur in 8 years.
- Savings-to-investment ratio is 6.39.
- Adjusted internal rate of return is 10.88.
- Life-cycle net savings is \$84,929.

The project also will comply with a City of Los Angeles mandate that requires existing fixtures to be replaced only with low-consumption models.

- Anticipated water and sewer billing rates for the next 2 years, if available from the utility.
- Records that show actual water use for the last 2 years, from both source meters and submeters, and including any water meter calibration test results so you can adjust past meter readings to reflect actual water use.<sup>1</sup>

### **Conducting a Comprehensive Water-Use Survey**

After you have collected the information outlined in "Identifying Significant Water-Use Factors" above, you are ready to begin the survey. The exact extent of a water survey will depend on the size of the building, the complexity of its systems, and the survey budget. The more comprehensive the survey, the greater the value of the resulting water management options and cost savings (refer to "Sample Water Survey Results").

#### **The Survey Team**

The first step is to assemble a team of professionals and identify their functions. Your survey team may consist of a combination of the following:

- Representatives from your facility's management.
- The director of the physical plant or the chief operating engineer.
- A representative from the maintenance department.
- Design or water management consultants.
- Qualified contractors who specialize in plumbing and mechanical, landscape, or other water management fields (refer to "Selecting a Contractor").

Depending on the policies of your local water utility, a representative may or may not wish to be involved in the on-site inspection portion of the survey. A utility survey should be conducted separately (see Utility Assistance section).

#### **Conducting the Survey**

Once you have your survey team assembled, you are ready to begin. A detailed survey should include the steps outlined below:

- Walk through your facility, and through direct observation and measurements, identify and list all equipment that uses water: faucets, toilets, showerheads, drinking fountains, kitchen equipment,

---

*Measured flows will vary on different floors because of static head losses at higher elevations.*

---

water-using process equipment, cooling towers, heating boilers, and so forth. Note any discrepancies with information gathered during the previous step.

- Compare floorplans and plumbing drawings and schematics with actual conditions. Plans are often outdated; plumbing fixtures noted in plans may have been removed or disabled, and new fixtures may have been added after the drafting of the original plans.
- Record hours of operation for plumbing fixtures, devices, and all water-using processes or pieces of equipment. Note if a particular fixture, device, or piece of equipment uses water for more than one operation. Ice makers, for example, use water both for making ice and for cooling. When possible, determine actual schedules of plumbing fixture use by talking to operating personnel familiar with the building use.
- Verify operating schedules and the number of building occupants during different times of the day. This step is particularly critical if your building has a lot of visitors and foot traffic.
- Determine water pressure. If the pressure is not within the operating range of the fixture, the equipment will not operate properly.
- Determine the amount of water used by each type of plumbing fixture or device within the facility. Log or record the consumption data for each device (most will have it printed or engraved on the equipment itself). If your equipment has been retrofitted or the amount is not visible, examine the fixture and measure or estimate the flowrate.

---

*Your local water utility can serve as a source of information and help gauge your water efficiency*

---

When field-testing the flow of water through fixtures, it is usually sufficient to take sample readings at a few representative fixtures located throughout the facility. When measuring the flow rate by fixtures such as faucets that can operate at different settings, set the fixture at a typical temperature and adjust it to an average flowrate. Keep in mind that measured flows will vary on different floors because of static head losses at higher elevations.

- Measure the quantity of water used by other water-consuming equipment. You may need to install temporary water meters to gauge water use by large water-using equipment.

**Figure 3-1. Water Balance Diagram.**

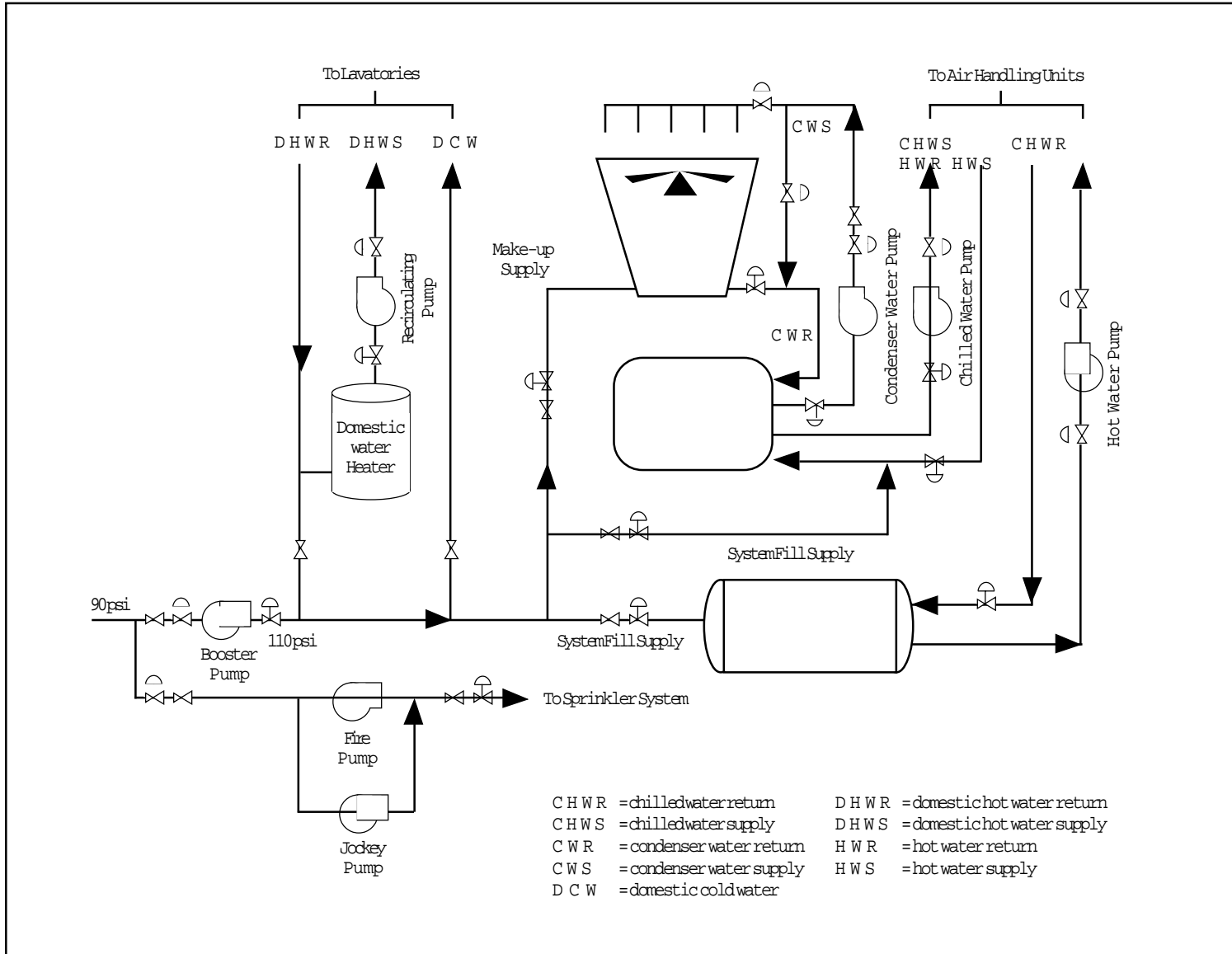

Compare the equipment water use measurements with the manufacturers' rated flow amounts; some equipment may be operating with higher water consumption rates than necessary. If there is a significant difference, consider having qualified personnel review equipment operation and make adjustments to lower water consumption.

---

*Ask your utility representative to review your current rate structure and other options that may exist.*

---

- Determine daily facility consumption rates from water meter and submeter readings and other sources. This step will also help to prepare for monitoring water use reductions after beginning the water management program. After the survey is completed, continue to take meter readings on a monthly basis.
- Identify the direction that water is flowing within a building and its quality. Knowing the quality of water as it travels through a facility is important because discharges from one use could possibly be used as the supply water for a second use (see Chapter 6, Recycling). When examining water quality, if possible, consider its temperature; chemical makeup, including pH level, total dissolved solids, and conductivity; and the amount of solid waste it carries.

After you finish this step of the water survey, you should be able to track all uses of water in a building (see Figure 3-1). Ideally, you will be able to determine the amount of water consumed, lost to evaporation, and discharged for treatment. Also, remember that throughout the water survey, you should be observing and noting appropriate technologies to retrofit or replace existing products.

#### **Utility Assistance**

At this point, if your local water utility has not yet been involved in the survey, you want to ask them what services they provide and at what cost.

Your local water utility can be helpful in two ways. First, it can serve as a source of information, and, second, it can help you to detect leaks or install or adjust meters and water-pressure-reduction valves.

**Leak Detection.** Leaks, low water pressure, and other problems may exist within the water distribution lines outside a given facility. During a utility water survey, the utility representative will visit the affected area to detect where water losses may be occurring (for example, in water distribution lines, piping, and connections). Leaks are not uncommon in areas where utility water pressure and demand are



high. Many surveys are also designed to detect unmetered water delivered through fire hydrants, water taken illegally from the distribution lines, inoperative system controls, and water used in flushing water mains and sewers. If any of these problems are found, the utility will usually fix them at its own expense.

**Meters.** Water submeters, which measure the amount of water used for specific processes in a building, can be installed on a facility's water distribution lines to provide more accurate readings (information that is not provided by standard meters). That knowledge helps pinpoint areas of high water use (and thus, areas with great savings potential) and evaluate their consumption on a monthly basis. Just having a greater awareness of how water is specifically used in a building has helped some building managers change their water use patterns, resulting in a 13- to 45-percent savings.

Installing meters may alter the facility's water rate structure; as a facility manager, you should ask your utility representative to review your current rate structure and other options that may exist. Traditionally, large water users have been charged either a *flat or declining block rate*. Under a flat rate, the price per unit of water remains at one cost regardless of the amount of water consumed, offering no incentive to cut water use. A declining block rate rewards waste by charging less for each unit as more water is used; fortunately, these rate structures are becoming less commonplace.

A more progressive rate structure that encourages water conservation is a *graduated rate*. With a graduated rate, the utility charges a certain amount for the first 150,000 gallons provided per month, a slightly higher rate for the next 150,000 gallons, and a graduated rate for each sequential 150,000 gallons. This type of rate schedule provides a stronger economic incentive for facility managers to use less water than when they are billed on a flat or declining block rate. Furthermore, some sewage or wastewater treatment facilities may offer similar rate structures, further encouraging water conservation. Whichever your current rate structure, it is important to determine if you have options, and if any provide you with savings.

---

*Your approach to selecting options should be comprehensive, considering not only the cost of maintaining a retrofit versus replacement but also Federal and state regulations*

---

## **Comprehensive Water Management Program Reduces Annual Water Consumption by 1.6 Million Gallons at Federal Facility**

*"These projects are expected to continue to accrue savings of approximately 10 percent per year and will stay in effect indefinitely," commented Tim Rollins, Building Manager of the Nuclear Regulatory Commission's (NRC) One White Flint North Building in Rockville, Maryland. "The water conservation program extends to 1,300 NRC employees, as well as the facility management contractor responsible for operating and maintaining the building."*

During 1992, personnel at this facility developed and implemented a water conservation program that reduced annual water consumption by more than 1.6 million gallons. This savings represents an 18.6-percent decrease compared to 1991.

The following actions were responsible for the savings:

- *Reducing the lawn watering schedule.* The watering schedule was reduced by closely monitoring the weather forecast and cancelling watering schedules when the weather forecast predicted rain. All watering was performed in the morning to minimize evaporation.
- *Installing water efficiency devices in restrooms.* Water restrictors were installed on the faucets, and water-reducing flush valves were installed on toilets.
- *Upgrading valves on heat exchangers.* New water supply valves were installed on the heat exchangers to eliminate leaks.
- *Inspecting equipment.* Equipment inspection was increased to identify water losses. Repairs were made quickly when needed.
- *Installing electronic float valves on cooling towers.* Electronic float valves were installed to monitor tower water levels and to prevent excessive water loss during bleed-off.
- *Installing cooling tower sewer submeters.* Although the submeters do not reduce water consumption, they accurately measure water not being returned to the sewer because of cooling tower evaporation. Some utilities may offer credits for water that was evaporated rather than being returned to the sewer. The installation of the submeters reduced sewer charges by \$15,235.

Employees hold conservation meetings, distribute literature, and place water-related notices on bulletin boards. NRC's outreach and education activities include publishing the *NRC Newsletter*, which provides information to employees on environmental issues, and sponsorship of employee awareness programs, which promote water conservation.

### Pressure Reduction Valves

Lowering the water pressure level on a facility's distribution lines outside a building can often conserve water while still maintaining adequate pressure. Water utilities can install pressure-reducing valves (PRVs) that will regulate water pressure, typically maintained at between 50 and 60 pounds per square inch (psi) for maximum efficiency. Ask your utility if your facility could benefit by installing PRVs.

## Step 2. Explore and Evaluate Water Management Options

After compiling water-consumption and use data and obtaining a true idea of water costs, you then need to identify your water management options. That is, you need to determine which fixtures and equipment produce water savings while maintaining or improving the water functions and services your facility and its occupants require (refer to "Comprehensive Water Management Program Reduces Annual Water Consumption by 1.6 Million Gallons at Federal Facility").

Most of your options will fall into three main categories:

- Plumbing fixtures
- Heating, ventilating, and air-conditioning systems
- Landscape irrigation

Chapter 5 provides a detailed discussion of each of these options.

Your approach to examining these options should be comprehensive. Explore all equipment and devices against the factors influencing your water use. Complete replacement is typically not an option for most facilities, and may not necessarily be the best solution. An older facility with inconsistent water pressure, for example, may not be suitable for a low-flow toilet replacement because the quantity of use or abuse (such as flushing excess paper down the toilet) will create related maintenance and performance problems, which could actually increase costs. Often, simple procedural changes in maintenance or operation can produce substantive water savings. A constantly running toilet, for example, can waste 6,000 gallons of water per day. Checking and replacing valves and ballcocks regularly can save this otherwise wasted water.

---

*The total cost of water goes well beyond water and sewer bills*

---

---

*A life-cycle cost analysis takes into account the "time value" of money, rather than just the initial equipment cost*

---

As you weigh your fixture and equipment options, consider the Federal legislation and state water conservation regulations. Some states that have experienced water shortages in the past, and those concerned about water use and conservation in general, have passed regulations that exceed Federal legislation. Arizona, California, and Maryland have laws restricting water use in toilets, for example, while California, New York, and Rhode Island have imposed special standards on low-flow showerheads and faucets.

### **Step 3: Conduct Life-Cycle Cost Analyses and Explore Financing Options**

In steps 1 and 2, you examined your facility's current water use and costs associated with your existing plumbing equipment and devices, while in step 3, you explored which fixtures and equipment provide the water savings desired. Armed with this knowledge, you can now look at the cost and funding options before making an investment decision. In this step, determine what you can afford to do and innovative ways you might finance it.

**Note: Section 401 of Executive Order 13123 requires that "Agencies shall use life-cycle cost analysis in making decisions about investments in products, services, construction, and other projects to lower the Federal Government's cost and to reduce energy and water consumption . . ."** Life-cycle cost analysis is detailed below.

As water efficiency options can be expensive and budgets are usually limited, it is critical that you choose those options most appropriate and cost-effective to your facility. At the same time, initial cost should not be the only reason for deciding which option is best. For example, replacing an existing heavy-use toilet with a low-flow model will require a larger initial investment than simply installing a toilet dam. However, the dam will require regular surveillance and maintenance, and the labor costs may quickly offset the initial low cost of the dam. Consult your facility's budget office throughout this process.

### Building Life-Cycle Cost Software (BLCC)

BLCC creates the life-cycle cost analysis from information about your facility gathered during the survey, including the following:

- Existing water bills.
- The results of the facility water consumption survey.
- Local water rates.
- Maintenance projections.
- Retrofit plans within the next 10 years.
- Utility rates escalated to future level. Although there are no water escalation rates, Federal agencies use Department of Energy rates.

The BLCC program includes on-line help for the data entry and an instruction manual that you can print on demand from your workstation.

### Associated BLCC Software and Technical Resources

**DISCOUNT:** A Program for Discounting Computations in Life-Cycle Cost Analyses, is a program that calculates discount factors and related present values, future values, and periodic payment values of cash flows occurring at specific points. DISCOUNT is available from NIST (NISTIR 4513), and is updated annually.

**NIST Handbook 135:** Life-Cycle Costing Manual for the Federal Energy Management Program, 1995 edition, National Institute of Standards and Technology. *Handbook 135* is a guide to understanding the LCC methodology and criteria established by the Federal Energy Management Program (FEMP) in 10 CFR 436A for the economic evaluation of energy and water conservation projects and renewable energy projects in all federal buildings.

**NIST training videos** An introduction to the FEMP LCC method is provided in the following three video training films: An Introduction to Life-Cycle Cost Analysis; Choosing Economic Evaluation Methods; and Uncertainty and Risk. They are available through the Office of Applied Economics at NIST by calling 301-975-6132.

---

*Initial cost should not be the only reason for deciding which option is best.*

---



---

*If possible, use prices that will be in effect at the time any water efficiency and conservation changes are actually made.*

---

## Total Cost of Water

The total cost of water used by a facility goes beyond the facility's water and sewer bills. You can determine the total cost by adding all expenses for water use for a year and divide the result by the quantity of water used during that year. To find the sum of all expenses for water use, be sure to include the following:

- The cost of the water purchased from water utilities. Water utility bills usually contain two components: a fixed charge and a charge based on the amount of water used. Do not include the fixed charge in the total, as this amount usually will not change with an increase or decrease in facility water efficiency.
- Energy cost of pumping water from wells.

---

*Partnerships with the private sector will become increasingly important. Two of the most effective partnerships are utility-sponsored demand-side management programs and energy savings performance contracts.*

---

### Discounted Payback, Simple Payback, and Uncertainty Assessment

Discounted Payback (DPB) and Simple Payback (SPB) measure the time required to recover initial investment costs. The payback period of a project is expressed as the number of years just sufficient for initial investment costs to be offset by cumulative annual savings. DPB is the preferred method of computing the payback period for a project because it requires that cash flows occurring each year be discounted to present value to adjust for the effect of inflation and the opportunity cost of money. However, DPB or SPB measure only the time required for accumulated savings to offset *initial* investment costs. Any costs or savings incurred during the remainder of the project life-cycle are ignored. DPB and SPB are therefore not appropriate measures of life-cycle cost effectiveness and should be used only as screening tools for qualifying projects for further economic evaluation.

### Uncertainty assessment

Cost estimates are typically uncertain because of imprecision in the underlying data and modeling assumptions. There are numerous methods for analyzing uncertainty and risk. The technique to be used depends on the degree of uncertainty and the size of the project. Deterministic analysis, such as *sensitivity analysis* and *breakeven analysis*, can be performed within the LCCA method without requiring additional computational aids. *Probability distributions* of economic measures may require more or less complex simulation techniques but may be warranted by the magnitude of some projects.

---

*Tip: Do not plan so closely that a delay in implementing one option throws the entire schedule off balance*

---

- Cost of pretreating and on-site pumping.
- Cost of water heating and cooling.
- Chemical or other treatment costs, including treating cooling tower or boiler feed water.
- Sewer costs, which can be based on the amount of water, dissolved solids, suspended solids, and the need for chemical or biological oxygen.

When combining these costs, you can use current prices. However, if possible, use prices that will be in effect at the time any water efficiency and conservation changes are actually made. That way, you can assess more accurately differences in cost savings realized by changing facility water use. After adding all costs, divide by the volume of water purchased during that same time period to find total cost per unit of water used.<sup>2</sup> Knowing the total cost per unit of water used is important because it can indicate savings realized by replacing or retrofitting with the options considered.

### **Life Cycle Cost Analysis**

Section 707 of Executive Order 13123 defines life-cycle costs as "...the sum of present values of investment costs, capital costs, installation costs, energy costs, operating costs, maintenance costs, and disposal costs over the life-time of the project, product, or measure." Stated another way, life-cycle cost analysis evaluates the total initial and operating and maintenance costs of a water efficiency option over time, taking into account the "time value" of money. In other words, analysis considers the cost over the life of the system, rather than just the initial equipment cost. For any water conservation project, life-cycle costs must be analyzed to determine the payback period. All options with periods of 10 years or fewer must be considered. LCCA is required by law and Executive Order, and there are relevant LCC procedures and tools that have been supported by the Department of Energy's Federal Energy Management Program (FEMP) and other agencies for over 20 years.

---

*Remember: When water-saving devices are properly used, they save water and meet your needs*

---



---

*Water-conserving technologies work only when water users are part of the solution*

---

<sup>2</sup>Black and Veatch, *A Guide to Commercial/Industrial Water Conservation* (Los Angeles, CA: City of Los Angeles Department of Water and Power).

### Down With the Clog

One of the major causes of clogged toilets and plumbing maintenance calls is the misuse of toilets as trash cans. In traditional gravity toilets, this practice did not seem to seriously impair the toilet's performance or harm the pipes, as the high volume of water made virtually any object flushable. With the 1.6-gpf ultra-low flow models, however, even if the papers appear to flush, there is less water to propel the waste through the pipes, and clogs can form down the line.

Your facility's janitorial staff will need to regularly empty sanitary receptacles and trash cans and post signs in restrooms to discourage people from flushing inappropriate things down the toilet.

LCCA is particularly suited to the evaluation of design alternatives that satisfy a required performance level, but that may have differing investment, operating, maintenance, or repair costs; and possibly different life spans. LCCA can be applied to any capital investment decision, and is particularly relevant when high initial costs are traded for reduced future cost obligations. The general principles of LCCA also apply to the evaluation of projects considered for alternative financing through an Energy Savings Performance Contract (ESPC) or a Utility Contract (UC).

---

*The Department of Energy determines each year the discount rate to be used in the LCCA of energy conservation, water conservation, and renewable energy projects in federal facilities.*

---

#### Critical Assumptions

The most critical assumptions of the LCC rules in 10 CFR 426A and OMB Circular A-94 concern the following:

- Discount rate
- DOE energy price escalation rates
- Use of constant or current dollars
- Study period
- Presumption of cost-effectiveness

#### How to Calculate Life Cycle Costs

To properly calculate life-cycle costs, you must adjust all dollar values on a comparable time basis. This time adjustment is necessary because receiving or expending a dollar in the future is not the same as receiving or expending a dollar today. To adjust dollar figures to a comparable time basis, convert all future costs to *present values*, as



though they were all to be incurred today. The time adjustment is accomplished through *discounting* future cash flows by using a *discount rate*. Special *discount factors* are calculated for one-time amounts, annually recurring uniform amounts, or annually recurring amounts that escalate at a constant or varying rate from year to year. The most frequently used discount factors for evaluating energy and water conservation, and renewable energy projects are as follows:

- SPV - Single Present Value Factor for finding the present value of a single future amount, such as the value today of a future replacement cost.
- UPV - Uniform Present Value Factor for finding the present value of a series of uniform annual amounts, such as the value today of the costs of future yearly routine maintenance.
- UPV\* - Modified Uniform Present Value Factor for finding the present value of a series of annual amounts escalating at a constant or a varying annual rate, such as yearly energy costs, when energy prices are expected to increase at a given annual *escalation rate*.

The values of future amounts, and of the discount rates and escalation rates incorporated into the discount factors, can be expressed in either of two ways: including or excluding projected *general price inflation*. It is essential that they all be treated consistently within a given LCCA. If general price inflation is included, the analysis is said to be in *current dollars* and requires the use of a *nominal* discount rate and *nominal* escalation rates; if it is excluded, the analysis is said to be in *constant dollars* and requires the use of a *real* discount rate and *real* escalation rates. Both approaches give the same LCC results.

The Department of Energy determines each year the discount rate to be used in the LCCA of energy conservation, water conservation, and renewable energy projects in federal facilities. According to 10 CFR 436A,

Subject to a ceiling of 10 percent and a floor of three percent the real discount rate shall be a 12 month average of the composite yields of all outstanding U.S. Treasury bonds neither due nor callable in less than ten years, as most recently reported by the Federal Reserve Board, adjusted to exclude estimated increases in the general level of prices consistent with projections of inflation in the most recent Economic Report of the President's Council of Economic Advisors.

---

*To find the total LCC of a project, add the present values of each kind of cost and subtract the present values of any positive cash flows such as a resale value (using the discount rate to convert all costs to present values).*

---

---

*Two of the most effective public/private partnerships are utility-sponsored demand-side management programs and energy savings performance contracts.*

---

The *nominal* discount rate is derived identically but is unadjusted for increases in the general level of prices.

The real discount rate and corresponding discount factors are updated annually on April 1 and published in NISTIR 85-3273, *Energy Price Indices and Discount Factors for Life-Cycle Cost Analysis*, the Annual Supplement to NIST Handbook 135.

### Life-Cycle Cost Formula

To find the total LCC of a project, add the present values of each kind of cost and subtract the present values of any positive cash flows such as a resale value (using the discount rate to convert all costs to present values). Use the following formula:

$$\text{Life-cycle cost} = \text{first cost} + \text{maintenance and repair} + \text{energy} + \text{water} + \text{replacement} - \text{salvage value.}$$

### LCC Software Packages

Several software packages have been developed to perform life-cycle costing analysis. The National Institutes of Standards and Technology have developed the Building Life-Cycle Cost (BLCC) computer program—available free of charge and specifically written for Federal agencies (refer to “Building Life-Cycle Cost Software”).<sup>3</sup> It complies with Handbook NBS 135, the *Life-Cycle Costing Manual for the Federal Energy Management Program*, and with Office of Management and Budget (OMB) Circular A-94, “Guidelines and Discount Rates for Benefits/Cost Analysis of Federal Programs.”

BLCC provides economic analysis of proposed capital investments that are expected to reduce long-term operating costs and maintenance of buildings or building systems. Two or more competing designs can be evaluated to determine which has the lowest total life-cycle cost. Or, a project can be compared against a “do-nothing” base case where no capital improvements are made.

BLCC is especially useful for evaluating the costs and benefits of energy and water management projects in buildings. Currently, however, there are no escalation rates for water available for use in the analysis. Alternately, natural gas or the consumer price index may be used as a substitute.

BLCC also calculates the following:

**Simple payback**—calculated by dividing initial investment by annual savings after taxes. The smaller it is, the better.

**Savings-to-investment ratio**—calculated by dividing savings over the life of an investment described in today's dollar value by initial investment. Savings-to-investment values should be greater than 1.

**Adjusted internal rate of return**—the interest rate represented by the cumulative savings compared to the initial investment.

**Net savings**—calculated by subtracting the life-cycle cost of the existing option from the life-cycle cost of the investment.

## Financing and Incentives

Your facility's budget office should have an idea as to what financing choices are available, both in- and out-of-house. Available financing options are detailed in Chapter 7, "Your Water Management Toolkit."

Although the bulk of Federal facility energy and water-conservation projects are still funded through direct appropriation of funds (\$179 out of \$193 million in FY 1996), in an era of declining Federal resources, partnerships with the private sector will become increasingly important.

Two of the most effective partnerships are utility-sponsored demand-side management programs and energy savings performance contracts. Congress has provided authorities that specifically allow, encourage, and expedite the use of these partnerships. Executive Order 13123 states that "where possible, water cost savings and associated energy cost savings shall be included in Energy-Savings Performance Contracts and other financing mechanisms." (For an explanation of energy savings performance contracts, see Chapter 7.)

See chapter 7 for an explanation of available financing options.

---

*Because many water efficiency options produce savings only when used properly, you must teach occupants how to use them.*

---

## **Step 4: Develop a Water Management Plan and a Work Schedule**

Once you have decided to make changes or modifications to your facility, choose those to be implemented based on the previous examination of current water use, occupant needs, and the results of life-cycle costing analysis. Prioritizing the selected water management options in this way will maximize cost, water, and energy savings while maintaining or improving occupant comfort and increasing facility efficiency. Because individual facilities vary according to building type and use, occupant needs, and equipment, water, and sewage costs, no one plan is right for all facilities. After choosing water efficiency options, you must then develop a comprehensive water management plan work schedule. Determine what funding is available for improvements and when, and the time required to complete the entire water management project. Examine large retrofit or replacement options or high-priority jobs to determine the time necessary to complete each. While some can be implemented in a few hours or days, others may require up to several months and the services of a professional contractor.

---

*Once work begins, closely monitor your program to ensure that it runs smoothly.*

---

When completing the schedule, do not plan so closely that a delay in implementing one option throws the entire schedule off balance. If a water management program is expected to take 18 months, the first 6 months should be planned in detail. Then, during those first 6 months, progress and savings should be closely monitored. As you develop a sense of your progress in the first 6 months, you will be better situated to plan the next phase (the next 6 months) with equal detail. In this way, remaining options are continually reviewed, helping to ensure that the plan is as realistic as possible and reflects the realities of actual progress compared to the initial plan.

## Step 5: Inform Building Occupants About Water Management

Before implementing your water management plan, be sure your facility occupants and visitors know what is going on and why. Most water-efficient fixtures will only yield the savings you expect when *users* are part of the solution.

Begin by sending all occupants a letter expressing support for the water management program and urging occupants to participate. The letter should explain why changes are being made and what difference they will make, and finally, why water management is necessary (see Appendix C for a sample letter). Signs should be posted near equipment and particularly in restrooms, so visitors are aware of water-saving initiatives in place.

Because many water efficiency options produce savings only when used properly, you must teach occupants how to use them. If low-flow toilets requiring 3.5 gpf are flushed twice to remove waste, for example, operating them this way will use as much or more water than the original fixtures they replaced. (Refer to "Down With the Clog.")

Bulletin boards, newsletters, and staff meetings should regularly discuss the progress of the water management program and might also attempt to change occupant water use overall. As part of your program, you may wish to incorporate some of the following suggestions:

- Set up a "hotline" to report leaks or other wastes of water to facility managers or maintenance personnel.
- Start a suggestions and incentives system to recognize water-saving ideas.
- Distribute flyers or pamphlets to promote the facility's water management plan or to educate occupants about good water use habits.
- Organize a slogan or poster competition.
- Start a water column in your building or agency newsletter, featuring how much water has been saved through the water management program.
- Prepare a water conservation display covering different aspects of water use affected by the water management

program (landscaping, low-flow plumbing products, water use habits, and the like) and place it in an appropriate location, such as the facility lobby or auditorium.<sup>4</sup>

## **Step 6: Implement the Water Management Plan**

Now you are ready to start installing retrofits or replacements and to introduce maintenance or operational changes. Once work begins, closely monitor your program to ensure that it runs smoothly. This part of your plan should include at least the following items:

- Call contractors to verify that their work is progressing as promised.
- Follow up regularly with operating and maintenance personnel to ensure that equipment is regularly checked and serviced.
- Listen to your facility's water users and keep communication lines open. If something is not working—and who better to judge than those who use the equipment and fixtures—you want them to tell you, so repairs or modifications can be made quickly.
- Check your water and sewer bills for a decrease in your consumption and billing.

## **Step 7: Monitor the Water Management Program**

Once implementation of your water management program has begun, you will want to carefully monitor water use to see what types of savings you are actually receiving. In addition to checking equipment, facility managers should maintain regular contact with operating and maintenance staff to verify that their work continues to produce water savings.

Finally, share your success. Not only should you let your building occupants know about how much water they are saving, you may also want to share the news with your community and encourage other groups and facilities to follow your example. Consider graphing or visually displaying water savings to emphasize successes.

---

*Share your  
success!*

---

# 4

## DROUGHT MANAGEMENT

According to the National Drought Mitigation Center (NDMC) in Nebraska, "Drought is a normal, recurrent feature of virtually every climate within the United States, so governments and communities should be prepared." But what, exactly, is a drought? According to NDMC, "No single operational definition of drought works in all circumstances . . . most drought planners now rely on mathematical indices to decide when to start implementing water conservation or measures in response to drought."

Nonetheless, NDMC describes four types of drought: *Meteorological* (a precipitation's departure from normal over some period of time); *agricultural drought* (not enough soil moisture to meet the needs of a particular crop at a particular time; happens after meteorological

---

*Drought planning  
needs to occur on  
Federal, state,  
regional, and local  
levels.*

---

### Underlying Principles of Developing a Drought Management Plan

- Bring the right people together
- Make sure they understand what needs to be accomplished
- Give them adequate data
- Make sure there is ongoing coordination and research
- Promote and test the plan before a drought situation

drought but before hydrological drought); *hydrological drought* (deficiencies in surface and subsurface water supplies; measured as streamflow, and as lake, reservoir, and groundwater levels); and *socioeconomic drought* (when a physical water shortage starts to affect people, individually and collectively).

### Developing a Drought Management Plan

Drought-plan specifics will vary by state, according to each state's particular situation (for example, western drought plans will have to compensate for wildfire prevention more than more urban northeastern states). And in fact, drought planning needs to occur on Federal, state, regional, and local levels. But the following basic steps from the NDMC will apply to developing almost any drought management plan:

---

*Use descriptive terms for actions that correspond with water-supply-alert levels (eg, "advisory" instead of "Phase 1")*

---

1. Appoint a drought task force
2. State the purpose and objectives of the drought plan
3. Seek stakeholder participation and resolve conflict
4. Identify drought risk and potential risk reduction actions
5. Write the official drought plan
6. Meet research needs and fill institutional gaps
7. Integrate science and policy
8. Publicize the drought plan
9. Teach people about drought
10. Continue to evaluate drought risk and the drought plan

A drought plan should address at least three primary needs: monitoring, impact and vulnerability assessment, and mitigation and response, according to NDMC. The plan should also clearly establish a working definition of a drought, and descriptive terms for actions that correspond with water-supply-alert levels (for example, "advisory," "alert," "emergency," and "rationing," rather than simply "Phase 1," "Phase 2," and so forth). The greater the severity of the drought, the greater the severity of the water-use-reduction measures. Equally important is clearly communicating to the public the different levels of change they will be expected to make in response to differing levels of drought severity (for example, encouraging dishwashers to be run only at full loads to restrictions on lawn watering, car washing, or crop irrigation).



## Specific Drought-Reduction Measures

### Mandatory Measures

New York State identifies three phases of drought management water-conservation measures: drought watch, drought warning, and drought emergency. Each phase is accompanied by successively more restrictive water-conservation measures. Under the phase 3 measures, the following activities are prohibited:

- Continued leaks from any water pipe, valve, faucet, etc.
- Vehicle washing
- Sidewalk washing
- Fountains and any other ornamental use of water
- Watering of lawns, golf courses, or trees (some exceptions for hand watering)
- Serving of water in restaurants (unless specifically requested by patrons)
- Use of any air-conditioner over two tons that uses public water, unless it has an approved water-recirculating device
- Filling a swimming pool with public water
- Showerhead flow exceeding 3 gallons per minute

### Voluntary Measures

During the drought of 1999—one of the worst of this century in Maryland and Virginia—the State of Maryland imposed similar mandatory water-conservation requirements to those above; and both states urged citizens to adopt voluntary water-conservation measures. Some voluntary water-conservation measures that Federal facilities managers could encourage during a drought are as follows:

- Only operating dishwashers and clothes washers at full loads
- Turning off the tap while brushing your teeth, washing your face, and shaving
- Reusing rinse water for watering plants
- Limiting watering of lawns to morning and evening hours, and watering with handheld hoses instead of sprinklers
- Washing cars with buckets of 3 gallons or less, instead of a running hose

---

*Facilities managers could give drought planners an inventory of existing state and federal drought programs*

---

### **The Role of Federal Facilities Managers**

So what is the role of Federal facilities managers during a drought? For starters, as the people who deal with water-conserving technologies (and peoples' water-use habits) on a day-to-day, "real-world" basis, facilities managers are an invaluable source of practical information to drought-mitigation planners. For example, facilities managers could give drought planners an inventory of current state and federal drought programs.

Currently, there is no one Federal drought management policy, and there is no consolidation of drought-related resources, laws, programs, etc. To address this situation, which often makes it hard to find the right information, the National Drought Policy Commission was created on July 16, 1998, by Public Law 105-1998 (the charter for the Commission became effective on January 4, 1999). The purpose of the commission is "to provide advice and recommendations on the creation of an integrated, coordinated Federal policy designed to prepare for and respond to serious drought emergencies." GSA facilities managers could provide valuable input into meeting the commission's mission.

---

*Facilities managers  
could circulate  
"drought-refresher"  
memos at the  
beginning of that  
region's drought  
season*

---

Following are some actions Federal facilities managers could do:

- Send out memos to their tenants requesting them to help conserve water.
- Contact states, local, and tribal governments to help with their drought mitigation plans.
- Serve on state, local, and tribal drought task forces.
- Keep building occupants informed about drought, as well as short- and long-term water supply issues, either through memos, emails, poster campaigns, and so forth.
- Circulate "drought-refresher" memos at the beginning of that region's drought season.
- Let occupants know that their efforts have contributed to the success of the drought-management plan.

### **Information Sources**

The National Drought Policy Commission, 1400 Independence Ave., S.W., Stop 0501, Washington D.C. 20250-0501. Tel: 202-720-3168; Fax 202-720-9688. The Commission has been tasked to better integrate federal, state, and tribal drought policies.

Soil Conservation Service: Provides monthly water supply report, including snowpack, stream flow, and reservoir storage conditions.

United States Geological Survey: Provides groundwater levels and daily stream flows at more than 300 measuring stations, some of which are telemetered.

National Weather Service: Daily and extended weather forecasts, including precipitation; drought severity chart and heating degree-day index.

National Oceanic and Atmospheric Administration: Has a Drought Information Center and many useful links. Also provides advanced very high resolution radiometer digital data. <http://www.noaa.gov/climate.html>

The National Drought Mitigation Center. Provides a wealth of drought-related information, and lots of helpful links. <http://enso.unl.edu/ndmc/>

# 5

## WATER-CONSERVING TECHNOLOGIES

First off, it is important to note that the basic technologies and approaches to conserving water have not fundamentally changed since the first publication of this handbook. What *has* changed is that the performance of water-saving devices has continually improved, as manufac-

---

*The performance of water-conserving devices, such as low-flush toilets, has improved considerably over the last few years, and consumer acceptance of them is now high.*

---

### The Most Common Water-Efficiency Measures in Business and Industry

- Recycle process water
- Improve maintenance to replace miscellaneous equipment and parts
- Use domestic water efficiency techniques, such as low-flush toilets, faucet aerators, and low-flow showerheads.
- Change operational practices
- Adjust cooling tower blowdown
- Reduce landscaping irrigation time schedules
- Adjust equipment
- Repair leaks
- Install spray nozzles
- Install and/or replace automatic shutoff nozzles
- Reduce dishwasher loads
- Turn off equipment when not in use

## Operation Changes and Low-Cost Replacement Devices

### Save More Than 1.4 Million Gallons of Fresh Water Annually at Federal Facility

*"We addressed the task of reducing water consumption logically," commented Tim Rollins, Building Manager of the Nuclear Regulatory Commission's (NRC) Phillips Building, Bethesda, MD. "We performed an extensive water survey and developed a prioritized list of water-consuming and potentially water-wasting devices to be retrofitted or replaced. Then, we developed a two-part program to implement the modifications and installations."*

During 1992, NRC personnel at the Phillips Building developed and implemented a water conservation program that reduced annual water consumption by more than 1.4 million gallons, a 32-percent decrease compared to 1991.

The program involved making the following modifications to the HVAC system:

- *Adjusting air-conditioning on/off times.* The air-conditioning system starts before normal occupancy and precools occupied areas. To reduce the cooling load even further, NRC programmed timeclocks on fresh-air fans to bring cooler air into the building at night.
- *Adjusting the thermostat to prevent overcooled areas.* To ensure that space was not overcooled, NRC inspected and recalibrated building thermostats, most of which required adjustment. New receiver controllers now operate zone valves, and new temperature controls cycle the cooling tower fans.
- *Adjusting chiller and air-conditioning operation.* NRC reduced maximum chiller operation from 100- to 75-percent of load capacity. Chiller controls are calibrated to provide a 20-minute delay to reach the 75-percent maximum capacity from the 35 percent initial capacity at startup. The summer operating hours of mechanical cooling by direct expansion units and by the chiller fell from 15 hours per day in 1991 to 14 hours per day in 1992.
- *Inspecting cooling tower overflow lines daily, at the beginning of each work shift.* Several copper floats in the cooling towers were either loosening or becoming waterlogged, causing water and chemicals to spill over the towers and into the drains. The floats were replaced whenever they continually permitted water and chemicals above the regulated levels.

The following plumbing fixtures and devices (many of which were over 30 years old) were also replaced, and the following modifications made:

- *Toilet ball valves.* Toilet ball valves were replaced with more reliable flapper-style valves. Engineers can now hear the new float valves cycle "open" and "close" and can identify leaking toilets more easily.
- *Faucet seats and washers.* Approximately 100 faucet seats and washers were replaced in the bathrooms and janitor's closets. Faucets that could not be repaired economically were replaced completely. New aerators were installed that limit water flow to 2.0 gpm. The total cost of replacing faucet seats and washers and new faucets was about \$1,000.
- *Routine bathroom inspections.* New monthly inspection requires examining every bathroom fixture in the building.

turers have refined their operation—often in response to consumer feedback.

This chapter discusses the uses of water both within a facility and on its grounds and describes water-saving technologies for each area. It is divided into three sections, each addressing a major area of water use. The first section, Plumbing Products, discusses a variety of water-using devices, ranging from toilets and urinals to dishwashers and photographic film washing and processing equipment. The second section, Heating, Ventilating, and Air-Conditioning Equipment, primarily examines space-conditioning equipment and includes discussions of cooling towers, single-pass coolers, and evaporative coolers. The last section, Landscape Irrigation, introduces ways to decrease water consumption outside a facility through improving watering practices and making use of xeriscaping. Throughout the chapter and where applicable, operation and maintenance modifications and retrofit and replacement options are featured for each technology discussed. *Note:* Recycling water consumed on-site is discussed in Chapter 5, "Recycling."

---

*It is important to evaluate each option not only on its ability to conserve water, but also on its practicality.*

---

For virtually every use of water in a building, facility managers can choose from a wide variety of water management options. Some options simply involve altering the water use habits of building occupants. Others, like changing the way fixtures and equipment are operated and maintained, can also save water. The most significant long-term savings, however, will probably require the retrofitting or replacement of fixtures and equipment.

In some instances, one option alone might achieve the desired savings (for example, retrofitting a showerhead by inserting a flow-restricting device). In others, a combination of options may be needed (for example, inserting flow restrictors and automatic sensors in bathroom faucets).

Some ways to reduce current water consumption will be immediately apparent, such as fixing a leaky faucet. Others, such as determining how many and what type of toilets to install, will require both product research and on-site use observation.

---

*To comply with the Energy Policy Act, changes must be life-cycle cost effective, with a payback occurring in 10 years or less.*

---

It is also important to remember that in order to comply with the Energy Policy Act, changes must be life-cycle cost effective, with a payback occurring in 10 years or less. Further, the Energy Policy Act also stipulates water consumption standards for products manufactured after January 1, 1994. These standards restrict showerheads and faucets to 2.5 gallons per minute (gpm), toilets to 1.6 gallons per flush (gpf), and urinals to 1 gpf. (Refer to Appendix A for specific Federal standards for plumbing fixtures.)

## **PLUMBING PRODUCTS**

**Toilets**

**Urinals**

**Showerheads**

**Faucets**

**Chilled Drinking Water Fountains**

**Dishwashers**

**Photographic Film Washing/Processing**

**Clothes Washers**

**Ice-Making Machines**

**Garbage Disposals**



It is important to evaluate each option not only on its ability to conserve water, but also on its practicality. For example, replacing a high-consumption fixture with a low-consumption fixture will enable you to realize the greatest amount of water savings over time. But, where limited budgets prevent the initial high price of replacement, other interim measures, such as retrofitting toilets with displacement devices, may be a more cost-effective way to save water (however, be aware that when you alter the water flow of a toilet, you are violating the manufacturer's original operating guidelines).

---

*In a typical office, replacing traditional gravity toilets with ultra-low-flow models could save 20 gallons per day per toilet*

---

Many toilets, urinals, showerheads, and faucets in use today were designed at a time when little regard was given to efficient water use. Consequently, many of these products waste water. Fortunately, there are several improvements that can be made to decrease waste of water, including simple operation, maintenance, and retrofit modifications.

While these changes can substantially save water, they are not always as effective as replacing the original product with one designed specifically with efficiency in mind. That is because these fixtures were not designed to operate with a reduced volume of water.

### **Low-Flush Toilets—New, Improved, and Now Well Received**

While it's true that there were some reports about consumer dissatisfaction with the performance of early models (those built right after enactment of the Energy Policy Act of 1992), low-flush toilets have gone through several improvement cycles since then (and even since the first publication of this handbook). As a result, consumer satisfaction with the new models is quite high: for example, 95% of consumers in Santa Rosa, California's "Go Low Flow" program found the new low-flow toilets as good or better than the replaced models. And surveys in Denver and New York City had similar results. The key to good performance of low-flush toilets is *proper installation by a certified plumber*. For the record, the Plumbing Manufacturers Institute agrees with the 1.6-gallon-per-flush standard set by EPACT, and is against the proposed repeal of these standards by (HR 859) Representative Joe Knollenberg (R-Mich.).

---

<sup>4</sup>Whalen, George. (The Plumbing Foundation, New York, NY.) Telephone conversation with author.

**Table 5-1. Toilet and Urinal Water Consumption by Model (gpf).**

Option	Traditional Model Water Consumption	Traditional Model Retrofits Available	Modern Model Water Consumption
<b>Toilets</b>			
Gravityflow	5 to 7	a,b,c,d	1.6 and 3.5
Flushvalve	5	c,d,e,f	1.6
<b>Pressurized tank system</b>			
	1.6	—	1.6
<b>Urinals</b>			
Siphonic jet	continuous flow	f,g,h	1
Blowout	2-3	h,f	1
Washout and washdown	2-3	f	1

*Note:* a=displacement devices, b=toilet dams, c=early closure devices, d=dual-flush adapters, e=insert or valve replacement devices, f=electronic sensors, g=water-conserving flushometer modifications, and h=timers.

This section outlines the most common plumbing products found in use in Federal facilities today. For each product discussed, opportunities for both reducing water losses and reducing the amount of water used by a product will be provided.

## Toilets

Americans flush almost 4.8 billion gallons of water down the toilet each day. When you consider that toilets account for nearly one-third of a building's water consumption, the potential for water savings through operation, maintenance, or retrofitting changes is one of the best water management options available. Unless your facility is relatively new or has been refurbished recently, chances are your toilets are consuming too much water.

All of these changes, however, whether a retrofit, operation, or maintenance modification, will not achieve the 1.6-gallon per flush (gpf) rate required of toilets manufactured after January 1, 1994. Instead, they will make your existing equipment work more efficiently until it can be replaced.

Replacing all existing toilets with 1.6-gpf ultra-low-flow (ULF) models would save almost 5,500 gallons of water

---

*Tip: The biggest water-waster, by far—and the most easily correctable—is a faulty flapper in toilets. Listen for a hiss or a trickling sound between flushes.*

---

**Figure 5-1. Gravity Flow Toilet.**

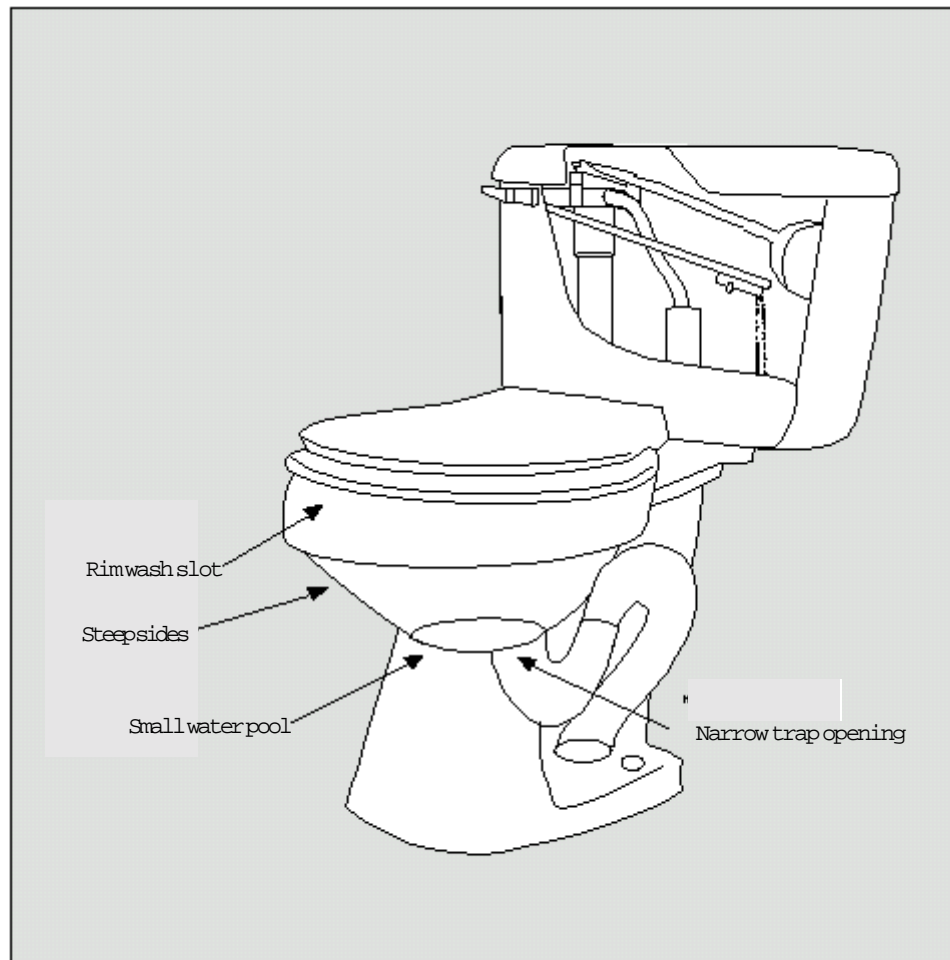

### **The New Design**

The ancient Romans were the first to use water in conjunction with sanitation, but the idea of a water closet (the precursor to today's toilet) did not emerge until 1775, when such a device was patented in Great Britain. From that time to the 1930s, an array of technological improvements were made to its design and performance.

By the 1970s, however, the average toilet was surprisingly similar to the 1930s model, both in design and water consumption, using 5 to 7 gallons per flush (gpf). At the end of the 1970s, however, the low-flow toilet, which consumed 3.5 gpf, was introduced and quickly became the industry standard. The 1990s have produced yet a better toilet design, the ultra-low-flush (ULF), which uses 1.6 gpf. ULF toilets, in turn, have now become the standard, and Federal regulations require that all toilets manufactured after January 1, 1994, consume no more than 1.6 gpf.

per person each year.<sup>2</sup> That's a lot of water. And when you compare the cost of purchasing a water-efficient toilet with the decrease in water and sewer use resulting from using this toilet, the toilet will usually pay for itself in less than 4 years. In almost all instances, the greatest amount of water savings can be achieved by replacement, and this option is preferred over retrofit alone. Table 5-1 compares the water consumption rates of traditional and modern toilet models.

Toilets are manufactured of vitreous china or sometimes plastic (except prison toilets, which are either aluminum or stainless steel). There are three major types of toilets: those that rely on gravity, those that use a flush valve, and those that comprise a pressurized tank system.

### Gravity Flow Toilets

The gravity flow toilet is the most common type of toilet. In these toilets, a rubber stopper releases water from the toilet's tank, and gravity forces the water, which collects the waste, into the bowl and through the trap (Figure 5-1). Traditionally, the gravity flow toilet has used about 5 to 7 gpf. If your facility was built before the 1970s and your plumbing has never been altered, you can safely assume you have gravity flow toilets that consume 5 to 7 gpf.

Over the past decade, a low-flow gravity toilet using 3.5 gpf, as well as one that uses 1.6 gpf, have been introduced into the marketplace. The original low-flow models were associated with performance problems; however, the most recent models have steeper sides and an exposed trapway, which increase the velocity of the flush and eliminate the need for double flushing.

If you are currently using gravity flow toilets in your facility you may want to consider implementing the following improvements:

#### Operation Modifications

- Adjust the flush valve to reduce the water consumed per flush. Ideally, the valve should be adjusted to use as little water as possible per flush without impeding waste removal or violating the manufacturer's recommendations.

---

*Tip: The biggest problem with improper flushing is improper installation. Make sure the flushing device is properly set. Seven out of 10 improperly flushing toilets are due to improper adjustment.*

---

### Maintenance Modifications

---

*Know your sewer infrastructure before replacing toilets. Older cast iron pipes with 4- or 6-inch diameters may have problems with 1.6 gallons per flush.*

---

- Check regularly for leaks (every 6 months).
- Periodically replace valves and ballcocks.
- Encourage cleaning and custodial crews to report problems.

### Retrofit Options

A variety of retrofit options are available for gravity toilets that are effective in lowering the consumption rate of the 5-gpf models to 3.5 gpf. Most of the retrofits cost under \$20 and improve the water efficiency of the toilet. These retrofits, however, may hamper the overall operation of the toilet and increase maintenance costs, as they often have a short life span and require frequent replacement or adjustment. Therefore, they may not be appropriate for many Federal facilities. A list of these devices follows:

- *Displacement devices*, such as bags or bottles, are designed to displace or reduce water flow by roughly 0.75 gpf. These devices are inexpensive and are relatively easy to install in tanks. Like most retrofit options, they require regular maintenance (Figure 5-2).
- *Toilet dams* are flexible inserts placed in a toilet tank that keep a limited amount of water—0.5 to 1 gpf per dam—out of the flush cycle. Dams can be used in pairs in large tanks to save even more water, and can last as long as 5 to 6 years. Because occasional difficulties are encountered while installing toilet dams, you may wish to consult a plumber before you begin retrofitting.
- *Early closure devices* replace or amend the existing flush valve in the tank, using the original amount of pressure to exert the same force in the flush, but with less water. These devices save 1 to 2 gpf and must be installed by a plumber.
- *Dual-flush adapters* adjust the system to use two flushes, saving as much as 0.6 to 1.2 gpf. One flush is standard and discharges solids from the bowl, while the

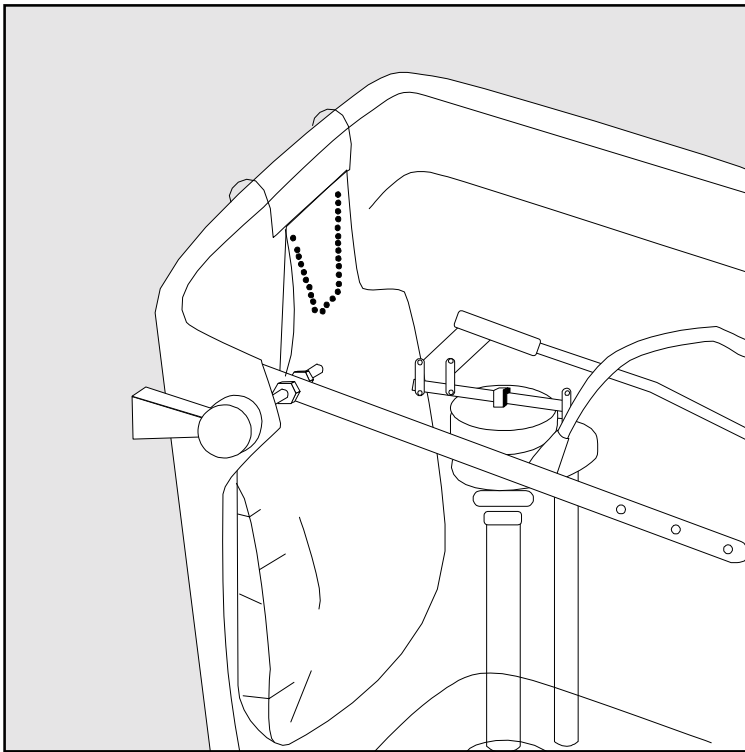
**Figure 5-2. Toilet Displacement Bag.**

---

*Tip: Both the low-flow valves and bowls should be replaced simultaneously. A 1.6-gpf valve will only perform adequately with an appropriately designed 1.6-gpf bowl.*

---

second, smaller flush, removes liquids and paper. With this retrofit, however, it is important that you teach users how to operate this equipment properly, and that you install signs in the restrooms to remind them of the procedure.

### **Replacement Options**

None of the above retrofits achieves a flow rate of only 1.6 gpf. Therefore, if your facility currently uses 3.5-gpf to 7-gpf gravity flush toilets, to maximize water savings, if financially feasible, they should be replaced with toilets specifically designed to use 1.6 gpf.

### **Flush Valve Toilets**

A second type of toilet, the flush valve or flushometer, is a tankless toilet. In these toilets, the flush valve is attached to a pressurized water supply pipe. The valve is designed so that when activated, the connecting pipe supplies water to the toilet at a flow rate necessary to

properly flush waste into the sanitary sewer system (Figure 5-3).

Most facilities use flush valve toilets. Water efficiency modifications for these toilets follow:

**Operation Modifications**

- Adjust the flush valve to reduce the water consumed per flush. Ideally, the valve should be adjusted to use as little water as possible per flush without impeding waste removal or violating the manufacturer's recommendations.

---

*Tip: Some toilet retrofit options can increase maintenance costs*

---

**Maintenance Modifications**

- Check regularly for leaks (every 6 months).
- Periodically replace diaphragm or other worn parts.

**Retrofit Options**

A variety of retrofit options for flush valve toilets are effective in lowering the consumption rate of the 5-gpf models to 3.5 gpf. Most of the retrofits are inexpensive and improve the water efficiency of the toilet. Some of the retrofit options, however, may hamper the toilet's opera-

**Figure 5-3. Flush Valve Toilet.**



tion and increase maintenance costs, as the devices often have a short lifespan and require frequent replacement or adjustment. Following are retrofit options:

- *Early closure devices* replace or amend the existing flush valve, using the original amount of pressure to exert the same force in the flush, but less water. These devices save 1 to 2 gpf, and require a plumber to install.
- *Dual-flush adapters* adjust the system to use two flushes, saving as much as 0.6 to 1.2 gpf. The first flush is standard and discharges solids from the bowl, while the second, smaller flush removes liquids and paper. With this retrofit, however, it is important that you teach users how to operate this equipment properly, and that you install signs in the restrooms to remind them of the procedure.
- *Insert or valve replacement devices* can reduce flush volumes by approximately 1 gpf. Some of these devices consist of plastic orifices perforated with holes in a wheel-and-spoke pattern, while others actually replace existing valve mechanisms.

All of the above replacement devices limit water use of existing flush valve toilets. The most expensive retrofit for this toilet is the installation of electronic sensors. These sensors automatically activate flushing, making it unwieldy for people to flush twice.

There are two types of electronic sensor systems, as follows:

- *Infrared sensors* emit an infrared light beam to detect motion. The beam is broken first when an individual sits on the toilet, and again when the individual rises, activating the toilet flush. The sensor is specifically designed not to detect passersby and automatically resets itself after each use.
- *Ultrasonic sensors* function similarly to an infrared sensor, but use high-frequency sound waves to detect motion.

---

*How Low Can They Go? At least one manufacturer produces a toilet that uses only 1 gallon per flush.*

---



### **Replacement Options**

The most effective replacement option for a flush valve toilet is a 1.6-gpf flush valve toilet. Such a replacement will typically result in a greater water savings than that realized through retrofitting or adjusting an existing flush valve toilet. Manufacturers have developed a wide variety of models, many of which would be both affordable and suitable for most facilities.

### **Pressurized Tank System Toilets**

The third type of toilet, which was specifically designed to use 1.6 gpf, is a pressurized tank system. This is the most modern and effective toilet on the market, and is the most popular replacement for gravity toilets.

In this toilet, a pocket of air in the tank exerts pressure on the water. Pressure is maintained until the flush valve is released. Release of the flush valve forces the pressurized water down into the bowl at a force 500 times greater than conventional 5-gpf gravity toilets (Figure 5-4).

**Figure 5-4. Pressurized Tank Toilet.**

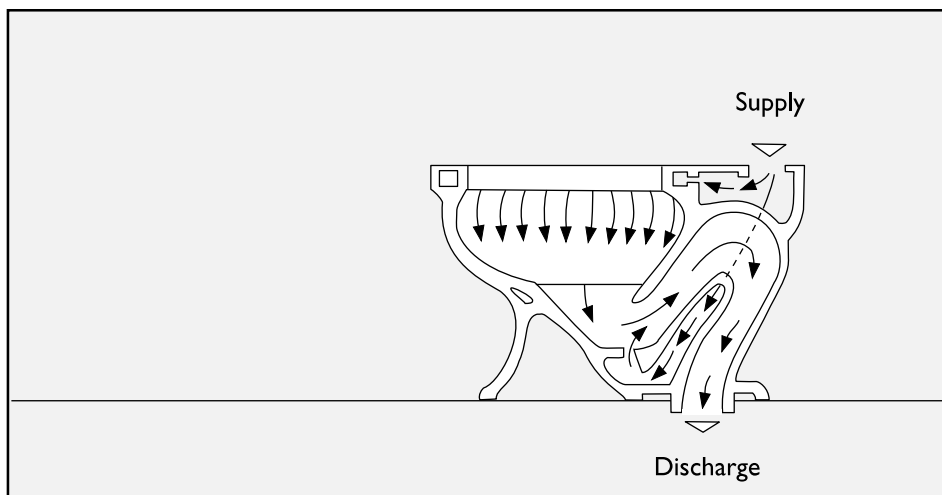

**Figure 5-5. Blowout Toilet Schematic.**

For commercial applications, a “blowout” toilet, similar to the pressurized tank system in terms of water efficiency and disposal, is available (Figure 5-5). In this toilet, the pressurized tank is located behind a wall.

To ensure peak performance of these toilets it is important to check regularly for leaks.

### **Composting Toilets**

Where sewers or septic tanks are not available, composting and incinerating toilets could be used. However, uses are limited, and before purchasing them, make sure they conform to building inspection programs and local codes.

### **Urinals**

Most urinals in use today consume 2 to 3 gpf. There are also urinals that use 1.5 gpf, and to comply with recent Federal guidelines, all new urinals use 1 gpf.

Urinals are manufactured primarily as floor-mounted or wall-mounted, in a number of sizes and shapes. The wall-mounted models are the most popular because of the advantages they offer in both cleaning and maintenance.

Figure 5-6. Placement of Timeclock-Activated Control on Urinals.

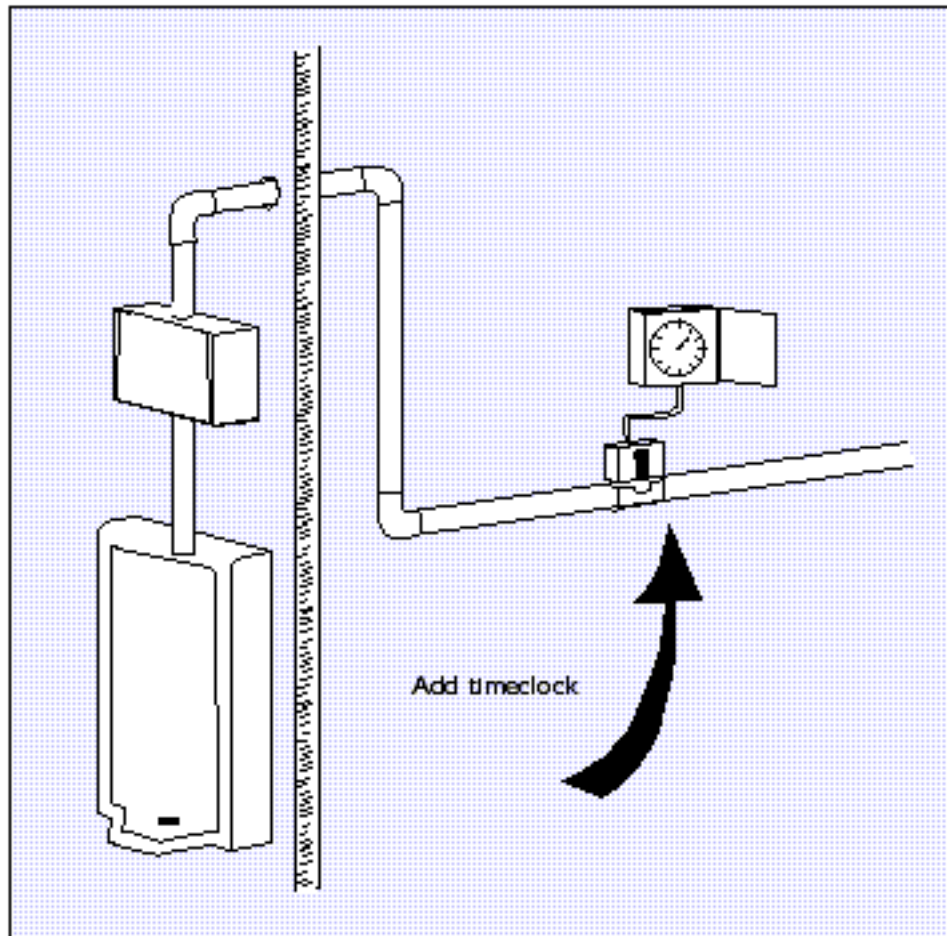

As with toilets, flushing is traditionally accomplished by means of a flush valve, water tank, or, in the case of trough urinals, by a washdown pipe assembly that provides a continuous or intermittent flow of a regulated volume of water. In addition, there are also urinals that do not use water in the traditional sense. They operate by using a biodegradable liquid as a flushing medium and a special trap insert. They have been operating in Europe in public facilities and schools for some time; however, to date, their application in the United States has been limited.

### Siphonic Jet Urinal

The most common type of urinal is a siphonic jet urinal. These urinals have been designed to accommodate greater levels of traffic. These urinals have elevated flush tanks

and actually provide a flushing action capable of removing foreign matter such as cigarette butts, gum wrappers, and the like. They operate through the use of a siphon device, which automatically discharges the tank's contents when the water level in the tank reaches a certain height.

These urinals are more sanitary than washout urinals in that they provide for a periodic cleansing of the urinal without the need for user assistance. They also require less maintenance in that they do not contain a flushing mechanism that can be easily broken or vandalized. Their primary disadvantage is that water flows through them constantly—day and night, every day of the year.

Water efficiency modifications for these urinals follow:

#### **Maintenance Modifications**

- Check regularly for leaks (every 6 months).
- Periodically check the pin hole and rubber diaphragm, and replace the diaphragm if necessary.

#### **Retrofit Options**

- *Adjust/retrofit flushometer valves.* Existing flushometer valves can be fitted with water-conserving parts that reduce the water consumption in the valve, as long as these adjustments meet flushometer and fixture manufacturer's recommendations.
- Use a *timer.* A timer can be used to control the removal of wastes that collect over time as a result of multiple uses. To eliminate water waste created from a urinal that flushes a small amount of water periodically, timers can be used to stop the flow of water when the building is not occupied (Figure 5-6).

#### **Replacement Options**

- Replace with models that have been designed to operate with only 1 gpf. A wide variety of models is currently on the market.

#### **Washout and Washdown Urinals**

In a washout or washdown urinal, water trickles into the basin and is washed out of the basin and down the pipes

using a mechanical or pushbutton handle. These urinals are intended to remove liquid wastes only and are most commonly found in low-use areas.

Water efficiency modifications for these urinals follow:

#### **Maintenance Modifications**

- Check regularly for leaks (every 6 months).
- Encourage cleaning and custodial crews to report problems.

#### **Retrofit Options**

- Urinals can be fitted with *infrared* or *ultrasound sensor-activated controls* that automatically flush after the urinal is used, helping to eliminate unnecessary double flushing.

#### **Replacement Options**

- Replace 1.5-gpf to 3-gpf models with 1-gpf models.

#### **Blowout Urinal**

Blowout urinals are most commonly found in areas of high traffic, such as airports or sports arenas. These urinals consist of an elevated flush tank located behind a wall in back of the urinal. Similar to a siphonic jet urinal, when the waste and water level reaches a specific height in the tank, a hydraulic flushing mechanism automatically empties the tank contents (including foreign matter).

#### **Maintenance Modifications**

- Check regularly for leaks (every 6 months).

#### **Replacement Options**

- Install timers or sensors to operate urinals only when the building is occupied.

#### **Waterless Urinals**

Waterless urinals use a combination chemical trap and seal to keep odors and sewer gas out of the area, without using any water.

---

*Tip: To determine if a showerhead flow is greater than 3 gpm, place a wide-mouthed gallon bucket under the showerhead. If the container is filled in less than 20 seconds at the normal setting, the flow is greater than 3 gpm.*

---

**Figure 5-7. Shower Flow Restrictor.**

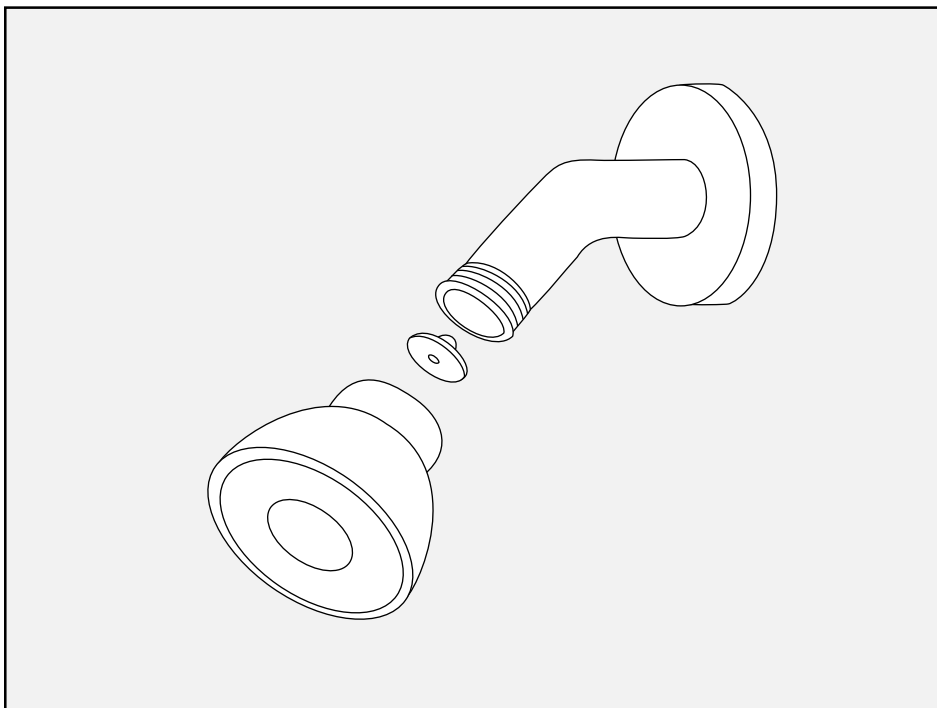

## Showerheads

Most existing showerheads consume considerably more water than necessary under normal operating conditions. For example, a 5-minute shower using a conventional showerhead may consume from between 25 to 35 gallons of water.

While there are not many shower facilities in most office properties, there are some basic operation and maintenance modifications and retrofit and replacement options that can not only reduce water consumption, but will also substantially reduce the energy required to heat water.

### Conventional Showerhead

A conventional showerhead typically uses from 3 to 7 gallons per minute (gpm) of water at normal pressure, about 80 pounds per square inch (psi). An effective low-flow showerhead should have a flow rate of less than 3 gpm.

Some of the many modifications that can be made to existing showerheads to help them conserve water follow:

---

*Tip: Some low-flow showerheads that atomize water can make warm water feel a bit cold. Only purchase high-quality low-flow heads that fully drain when they are off.*

---

Figure 5-8. Temporary Cutoff Valve.

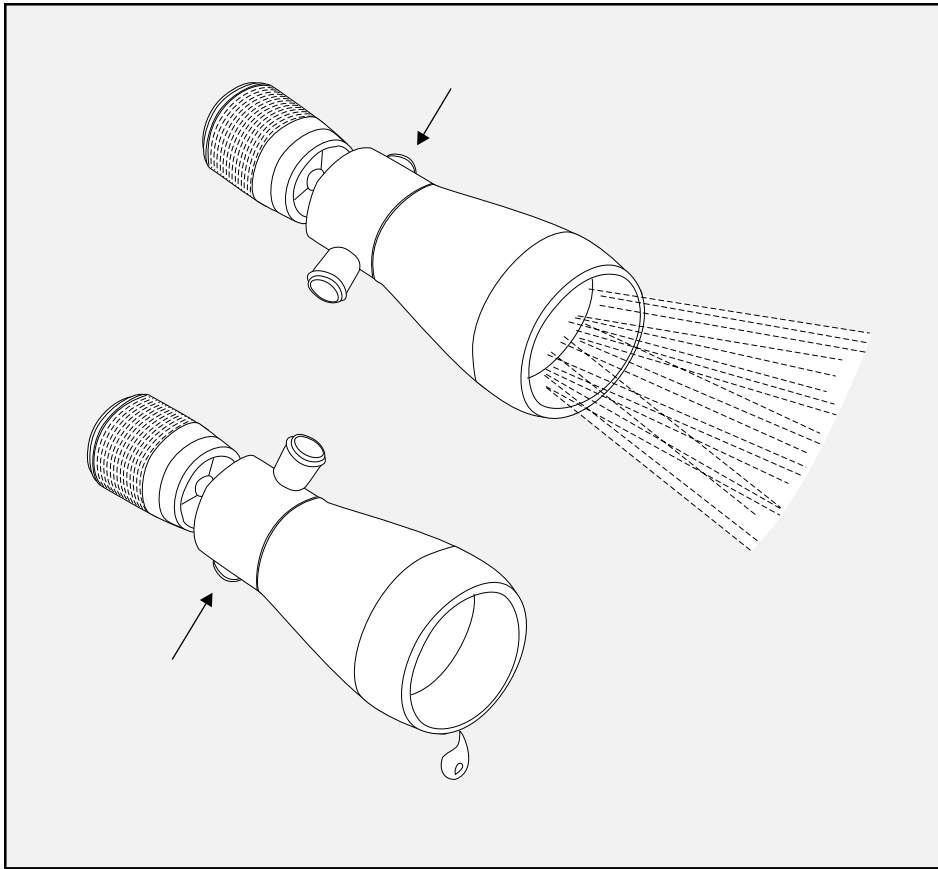
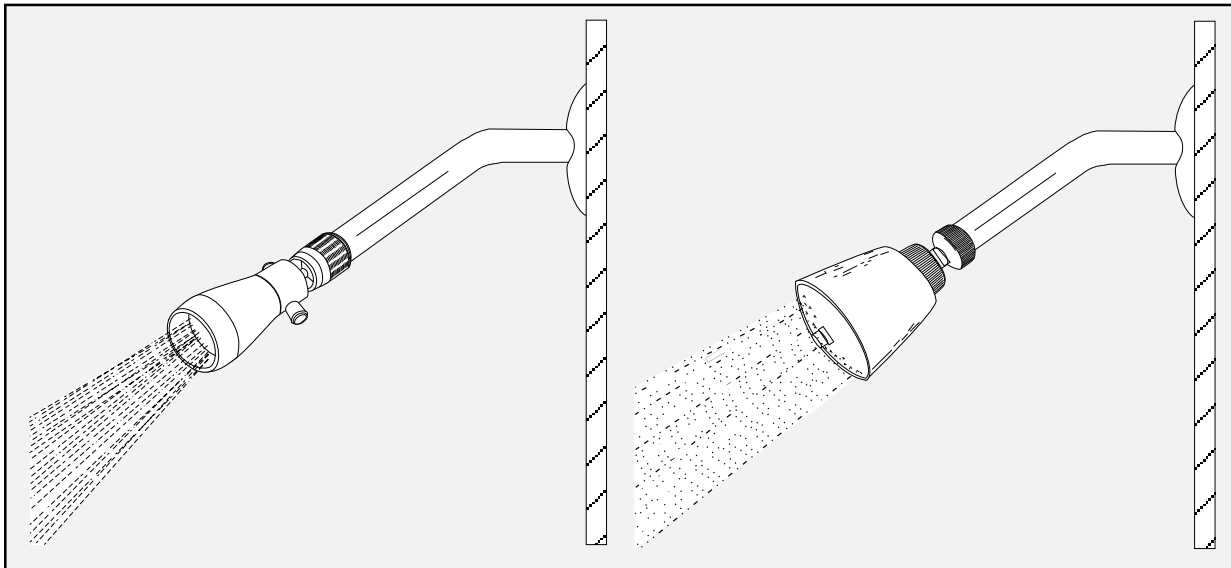

Figure 5-9. Atomizer and Pulsater Showerheads.



### Operation Modifications

- Encourage users to take shorter showers.
- Adjust the flow valve to reduce water flow.
- Lower the setting of the hot water temperature.

### Maintenance Modifications

- Check regularly for leaks.

### Retrofit Options

- *Flow restrictors*, washerlike disks that fit inside a showerhead, limit the waterflow (Figure 5-7). At less than \$5 each, they are one of the most cost-effective options available. Early designs for these restrictors were noisy at higher pressures. Such noises are uncommon with the newer high-quality products. Note: Some flow restrictors provide poor water pressure in some showerheads; a better, permanent solution is installing new, well-engineered low-flow showerheads.
- *Temporary cutoff valves*, usually attached or incorporated into a showerhead, cut off the water while an individual is soaping or shampooing (Figure 5-8). The water is then reactivated at the previous temperature, eliminating the need to remix the hot and cold water.

A consistent problem with the cutoff valve, however, is that often water is not reactivated at the previous temperature. Many times, the reactivated water is hot and may possibly burn the unsuspecting individual showering. Given the potential for burning, this may not be the best retrofit for a facility. However, if this option is selected, warning signs should be posted in the shower urging individuals to exercise caution.

### Replacement Options

The following replacement options maintain shower quality and achieve the 2.5-gpm requirement for all new showerhead fixtures. These products typically vary in price from \$3 to \$95.<sup>1</sup>

These showerheads were specifically designed to conserve water. They have a narrower spray area and a greater mix of air and water than conventional showerheads. These features

---

*Tip: To quickly determine how much water is wasted by a leaking faucet, go to [www.waterwiser.org](http://www.waterwiser.org) and use their "Drip Calculator" (click on "books" from the homepage).*

---



Figure 5-10. Faucet Aerator.

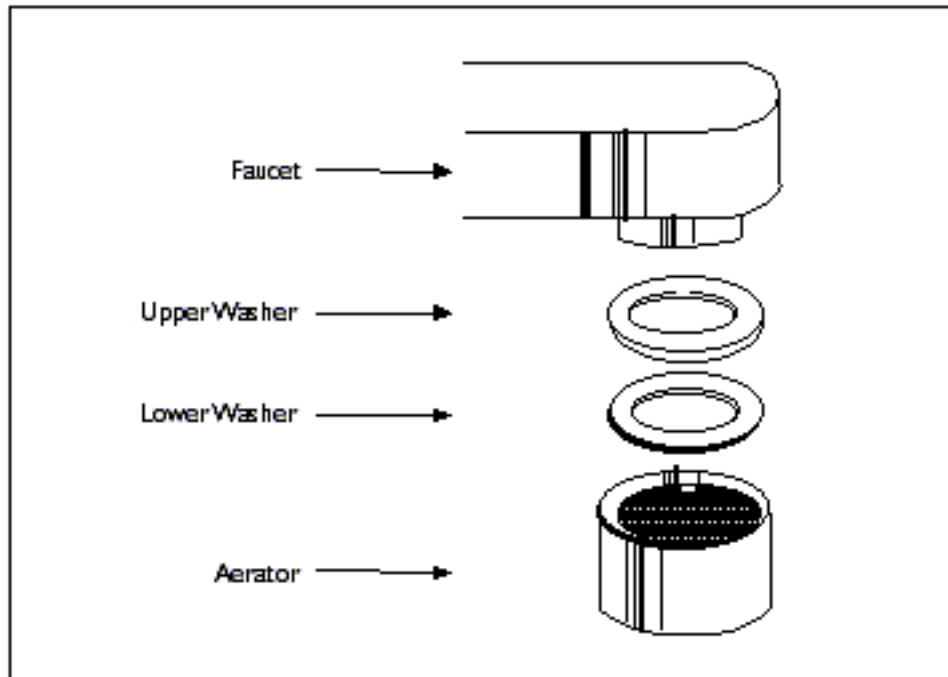

enable them to decrease the overall water consumption and at the same time provide what feels like a full-volume shower.

Several new models and their features include:

- *Atomizer showerheads* deliver water in small but plentiful droplets that wet larger surface areas (Figure 5-9).
- *Pulsaters* vary the spray patterns with a flow that pauses between spurts or through intermittent strong flow and light mist (Figure 5-9).
- *Aerators* mix air with fine water droplets to wet more surface area.

## Faucets

Tremendous amounts of water are wasted using conventional faucets with typical flow rates of 3 to 5 gpm. In fact, a leaky faucet—at one drip per second—can waste about 36 gallons of water a day.

Federal guidelines mandate that all lavatory and kitchen faucets and replacement aerators manufactured after January 1, 1994, consume no more than 2.5 gpm, measured at 80 psi. Metered valve faucets will be limited to 0.25 gallons per cycle after the same date. A lower 2.2-gpm limit for lavatory and kitchen faucets is being developed by the American National Standards Institute (ANSI), and will automatically become part of the Energy Policy Act requirements.

---

*A typical 10-second  
hand washing-  
standard for  
electronically  
controlled faucets)  
consumes only 1 pint  
of water*

---

### **Traditional Type: Manual Valves**

Most older faucet fixtures are hand-operated and have typical flow rates of 3 to 5 gpm. For a very low cost, there a variety of options available to help reduce their use of water.

#### **Operation Modifications**

- Adjust the flow valve to reduce water flow.

#### **Maintenance Modifications**

- Check regularly for leaks.

#### **Retrofit Options**

- *Flow restrictors*, like those used in showerheads, limit the maximum flow rate to a range of 0.5 to 2.5 gpm through a washerlike disk installed in the faucet head.
- *Aerators*, in the form of a head placed on top of your faucet head, add air to the flow stream, increasing the effectiveness of the flow and requiring less water (Figure 5-10).

#### **Replacement Options**

See the following low-flow options.

### **Low-Flow Type: Metered Valves**

Metered valve faucets deliver a preset amount of water and gradually shut off.

#### **Operation Modifications**

- Adjust the flow valve to reduce water flow.

### **Maintenance Modifications**

- Check regularly for leaks.

### **Low-Flow Type: Self-Closing**

The self-closing faucet is spring-loaded to shut off a few seconds after the user triggers it.

### **Operation Modifications**

- Adjust the flow valve to reduce water flow.

### **Maintenance Modifications**

- Check regularly for leaks.

### **Low-Flow Type: Infrared and Ultrasonic Sensors**

Sensors located in the faucet head activate the water flow when they detect the presence of an individual's hands or some other object beneath the faucet. When the hands are taken away, the flow is immediately cut off. These sensors automatically reset after each use, and are designed to not be activated by passerby.

The design of these faucets—requiring no touch to activate—prevents the spread of disease and also is helpful to users with disability.

### **Operation Modifications**

- Adjust flow valve to reduce water flow.

### **Maintenance Modifications**

- Check regularly for leaks.
- Check regularly to ensure that the flow controller connected to sensor does not become clogged with impurities carried by water. If necessary, consider filtering water before it reaches the faucet.

## **Chilled Water Drinking Fountains**

The Federal Government does not regulate water use for drinking fountains. As part of your water management plan,

---

*Spring-activated self-closing faucets can often become maintenance headaches if they stick or close too early. Consider infrared or ultrasonic faucets.*

---

and depending on the age of your fountain and its lead content, however, you may decide to modify or replace the drinking fountains in your facility.

There are also several inexpensive operation modifications that will enable you to reduce the energy used to chill drinking fountain water.

### **Individual Self-Contained**

An individual self-contained water cooler has a refrigeration unit that supplies chilled water to the fountain equipment. These units are typically scattered throughout a building.

#### **Operation Modifications**

- Raise the temperature 5°F. Most fountains typically chill water to around 65°F, although higher temperatures may be used.
- Provide proper insulation on piping, chiller, or central storage tank to save energy.
- Add an automatic timeclock to shut off the unit during unoccupied nighttime or weekend hours.

#### **Replacement Options**

Replacement options vary depending on the size of the facility and occupancy, existing equipment, and energy consumption. Consult with a contractor experienced in water fountains for further assistance.

### **Remote Chillers**

Remote chillers employ refrigeration units remotely located from their fountains, with each unit supplying water to several different locations.

#### **Operation Modifications**

- Raise the temperature 5°F. Most fountains typically chill water to around 65°F, although higher temperatures may be used.
- Provide proper insulation on piping, chiller, or central storage tank.
- Add an automatic timeclock to shut off the unit during unoccupied night or weekend hours.

---

*Success Story: A DOD cafeteria installation of new, multistage dishwashing equipment reduced water use by 500,000 gallons per year, with a payback of 2.7 years (Greening Federal Facilities, Sustainable Systems, Inc., 1997).*

---

- Install variable speed water pumps.

#### **Replacement Options**

Replacement options vary depending on the size of the facility and occupancy, existing equipment, and energy consumption. Consult with a contractor experienced in water fountains for further assistance.

#### **Central System**

A central system supplies chilled water to all drinking fountains in an entire building from one central location.

#### **Operation Modifications**

- Raise the temperature 5°F. Most fountains typically chill water to around 65°F, although higher temperatures may be used.
- Provide proper insulation on piping, chiller, or central storage tank.
- Add an automatic timeclock to shut off the unit during unoccupied night or weekend hours.
- Install variable speed water pumps.

#### **Replacement Options**

Replacement options vary depending on the size of the facility and occupancy, existing equipment, and energy consumption. Consult with a contractor experienced in water fountains for further assistance.

### **Dishwashers**

Dishwashers in your facility may also be using more water than they require. Most use between 2.5 to 8 gpm of water to both clean and sanitize. Energy guidelines for new dishwashers are quite strict, and many manufacturers are developing products that use both energy and water more efficiently.

If your dishwasher is still in good working condition and replacement at this time does not seem necessary, there are still several operational modifications that you should consider.

#### **Operation Modifications**

- In rack-type machines, only run the dishwasher if it is full.
- In conveyor-type machines, water should flow only when dishes are passing through the washer (even if the machine is on, water should not flow unless it is washing or rinsing).
- If possible, lower the water temperature. To avoid compromising the sanitation process, do not set the temperature below 180°F. Be aware that different situations may warrant various temperature ranges.
- Limit waterflow rates to those specified by the manufacturer.

#### **Retrofit Options**

- Install an *"electric eye" sensor system* in your conveyor-type machine so that the presence of dishes moving along the conveyor activates the water flow.

#### **Replacement Options**

- Install low-temperature dishwashers that sanitize primarily through the use of chemical agents rather than high water temperatures.
- Consider multistage dishwashers, which reuse water from the two rinse stages to prewash dishes. These models not only save water, but also detergent and rinse additives.

## Photographic Film Washing/Processing

Film processing also uses water, usually at a flow rate of 2 to 4 gpm. Water consumption as part of this process is currently not regulated by Federal guidelines, but you may still want to consider water management in this area.

### Retrofit Options

- Install a *flow meter* or *control valve* in the supply piping, and adjust to the minimum rate required to produce desired results.
- Install *pressure-reducing devices* on water supply equipment that does not require high pressure.
- Install *automatic shutoff valves* on equipment that uses fresh water to stop the flow when the equipment is not in use.

### Replacement Options

- Options vary depending on the size of the facility and existing equipment. Consult with a contractor or supplier experienced in film processors for further assistance.

## Clothes Washers

Don't forget about clothes washers when developing your water management plan. Also, because clothes washers are major consumers of hot water, choosing an efficient model can also reduce energy bill. Americans wash 55 billion loads of laundry annually, using about 2.2 trillion gallons of water.

### Operation Modifications

- Only wash full loads. If there is not enough laundry to fill the load, select a lower water-level setting. Using the small capacity setting can cut water use by 50%.
- Use the "suds saver" feature if your washer has one (this feature saves soapy water from one load to the next).

### Replacement Options

- Consider purchasing horizontal-axis washing machines. Horizontal-axis machines, long popular in Europe, are now

being manufactured by several American companies. By using a tumble-action washing, horizontal-axis machines use just over half the water of an average top-loading washer. Additionally, because horizontal-axis machines extract more water from clothes during the drying cycle, less energy is needed by clothes dryers.

## Ice-Making Machines

---

*Improving the efficiency of HVAC equipment can produce considerable water savings in your facility.*

---

Ice machines can use significant amounts of water, depending on the type of machine and the desired type of ice (ice with greater clarity requires more water, for example). The type of condenser an ice machine uses will have the largest effect on water use. Two types of condensers are available: air-cooled and water-cooled. Water-cooled machines use 10 times as much water as air-cooled machines. When comparing the two types of compressors, the compressor horsepower at design conditions is usually higher with air-cooled; however, operating costs frequently compare favorably over a full year.

## Garbage Disposals

Garbage disposals can waste a significant amount of water. Consider eliminating or minimizing their use in kitchen operations.



### **Operation Modifications**

- Use a mesh screen in the trap, or a strainer in the sink itself to collect food waste instead of using the garbage disposal.
- Use the disposal only when you are running water anyway (eg, when filling a rinse bucket)

### **Retrofit Options**

- Use an automatic valve or actuator that provides water only when the disposal is running.

### **Replacement Options**

- Use a grinder that recycles the slurry throughout the process.

# **HEATING, VENTILATING, AND AIR-CONDITIONING EQUIPMENT**

Cooling Towers

Single-Pass Cooling Equipment

Evaporative Coolers

Boilers/Steam Generators

---

*Cooling tower  
makeup-water  
systems should be  
inspected at least  
weekly during the  
cooling season*

---

Heating, ventilating, and air-conditioning (HVAC) equipment requires a great deal of water to meet a facility's heating and cooling needs. Most of this heating and cooling equipment frequently uses water inefficiently, either by not recycling it or by recycling it fewer times than possible. For these reasons, improving the efficiency of HVAC equipment can produce considerable water savings in your facility.

Because HVAC equipment—such as cooling towers—represents a tremendous capital expenditure, all options short of replacement should be pursued before actually replacing existing equipment.

## Cooling Towers

Cooling towers help regulate a building's air temperature either by rejecting heat from air-conditioning systems or by cooling hot equipment (refer to "How Cooling Towers Work"). In so doing, they use significant amounts of water. The thermal efficiency, proper operation, and longevity of the water cooling system all depend on the quality of water and its reuse or recycling potential.

In a cooling tower, water is initially wasted or lost in the process through evaporation, bleed-off (the release of built-up solids by removing a portion of the recirculating water that carries the dissolved solids), and drift or

### How Cooling Towers Work

Cooling towers recirculate a stream of warm water that is brought in contact with an air flow, causing a portion of the water to evaporate, thereby cooling the remaining portion of water. The water then circulates through a cooling system (or in some cases through large equipment), absorbs heat, and returns to the tower.

The recirculating water, commonly called a recirculating cooling loop, is usually chemically treated to prevent formation of mineral deposits, corrosion, and biological fouling (if untreated, the quality of water circulating through a cooling tower will deteriorate, greatly affecting its subsequent reuse). Because water that evaporates during the process is lost from the system, such a system is described as an "open" recirculating cooling loop.

Figure 5-11. Cooling Tower Schematic.

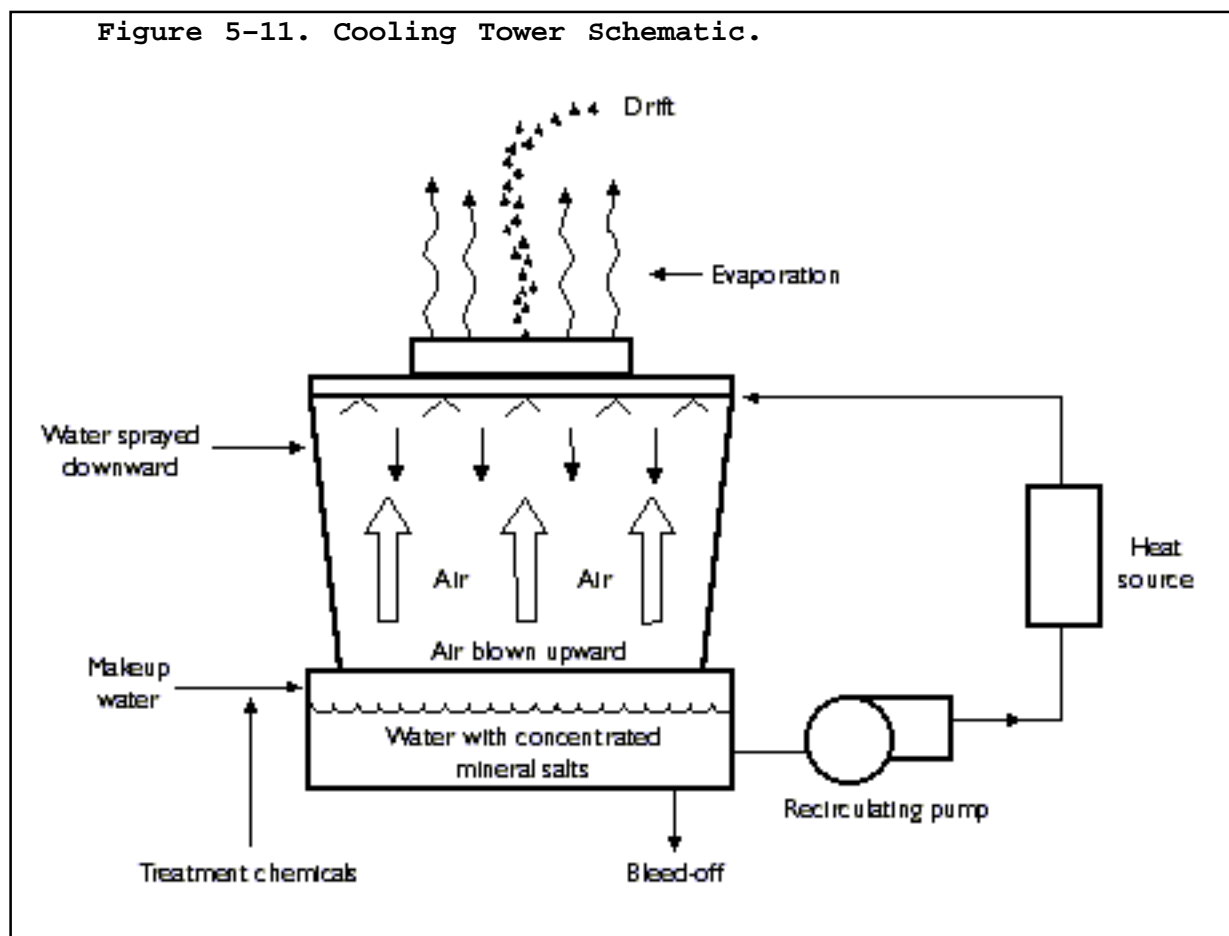

leaks. To replace the lost water and maintain its cooling function, more water (known as makeup water) must be added to the cooling tower system (see Figure 5-11).

Sometimes, water used for other equipment within a building can be recycled and reused for cooling tower makeup water with little or no pretreatment, including the following:

- Water used in a once-through cooling system.
- Pretreated effluent from other processes, provided that any chemicals used are compatible with the cooling tower system.
- High-quality municipal wastewater effluent or recycled water (where available).

### Operation Modifications

- Improve the method of releasing the tower bleed-off. Most cooling towers are bled-off automatically, when the conductivity of the water reaches a preset level. Try to operate the bleed-off on a more continuous basis, maintaining the conductivity of the tower closer to the limits, without wide fluctuations.

One way to do this is to install flow submeters on the makeup and bleed-off lines. (Refer to "Comprehensive Water Management Program Reduces Annual Water Consumption by 1.6 Million Gallons at Federal Facility" in Chapter 2) This practice enables the operator to verify the volume of water being used in the tower. Submeters should, at a minimum, be capable of totaling the flow. There are also submeters that display instantaneous flow. It is also important to read and record submeter data regularly.

- Use acid treatment, such as sulfuric or ascorbic where appropriate. When added to recirculating water, acid can improve the efficiency of the water by controlling scale buildup created from mineral deposits. Acid lowers the pH of the water, and is effective in converting a portion of the calcium bicarbonate, the primary cause of scale, to the more readily soluble calcium sulfate.

When using acid, several precautions should be taken:

- Use a timer to avoid overdoses that could damage the system. Add acid at points where the flow of water is well-mixed and reasonably rapid.
  - Train workers in the safe handling and use of acid to avoid contact with skin or eyes.
- All water treatment must be strictly monitored and performed by qualified workers.

### Retrofit Options

- Add an *automatic control* to shut off the unit during unoccupied night or weekend hours, or to operate it concurrently with chillers.

**Table 5-2. Advantages and Disadvantages of Cooling Tower Retrofit Options.**

Option	Disadvantages
Operational improvements Limited cycles of concentration	Low initial capital cost
Low operating cost Low maintenance requirements	
Sulfuric acid treatment	Low initial capital cost Low operating cost High cycles of concentration possible
Possible safety hazard Possible damage to system	
Sidestream filtration	Reduced possibility of fouling Higher operating efficiency Reduced maintenance Reduced bleed-off
Moderately high initial capital investment Limited effectiveness for solids removal Additional energy costs for pumping	
Ozonation	High cycles of concentration possible Elimination of conventional chemical treatment Does not require treatment before discharge to storm water or sewage system
High capital investment Complex system requiring outside contractor assistance Additional energy costs Possible health hazards	
Other sources of makeup water	Reduction in overall facility water consumption
Possible requirements for pretreatment Additional pretreatment chemical and energy costs Increased possibility for fouling if poor quality water is used	

- Use a *sidestream filtration system* composed of a rapid sand filter or high-efficiency cartridge filter to cleanse water. These systems draw water from the basin, filter out the sediment, and return the filtered water to the tower, enabling the system to operate more efficiently with less water.

This system is particularly effective where the water is cloudy, airborne contaminants are common, or cooling water passages are small and susceptible to clogging. Removing particles or suspended solids in the recirculating water enables the filtration system to operate more efficiently with less maintenance.

- Use an *ozonation system* to disinfect water and to reduce the rate of bleed-off without requiring the use of any additional chemicals. An ozonation system consists of an air compressor, ozone generator, diffuser or contractor, and a control system. While a powerful oxidizing agent, ozone has an effective life of less than 1 hour. Therefore, it must be generated at the site by passing cool, dry air (or pure oxygen gas) through a high voltage field between two electrodes (known as the corona discharge method).

Table 5-2 lists the advantages and disadvantages of cooling tower retrofit options.

#### **Replacement Options**

- A cooling tower service vendor can help you determine if a cooling tower replacement is necessary. Since replacing a cooling tower involves significant capital costs, the facility manager should investigate every retrofit option available and compare their benefits to the cost of a new cooling tower.

### **Single-Pass Cooling Equipment**

Single-pass cooling equipment—used in air-conditioners as well as some welding machines, hydraulic equipment, and vacuum pumps—uses and discards large amounts of water.

Implementing the following options can help you conserve energy and water in this type of equipment.

#### **Maintenance Modifications**

- Provide proper insulation on piping, chiller, or central storage tank.
- Keep coil clean to maximize heat exchange with the refrigerated enclosure.

#### **Retrofit Options**

- Add an *automatic control* to shut off the unit during unoccupied night or weekend hours.
- Single-pass cooling systems can usually be retrofitted to become *closed-loop cooling systems* that use recycled

water. Such a retrofit involves adding piping to return discharged water to the system inlet.

### **Replacement Options**

- Options vary depending on the size of the facility and existing equipment. You may want to replace your single-pass cooling system with a closed-loop chilled water system, which may also have the extra capacity to sufficiently cool small equipment, such as ice-making machines. It is best, however, before making a decision regarding equipment of this nature, to consult with a professional experienced in single-pass cooling equipment.

## **Evaporative Coolers**

Evaporative coolers increase the humidity and lower the temperature of the air. In these coolers, water flows to a reservoir, where its relative humidity is increased and air is cooled. Some water used by the cooler may be bled-off to reduce contaminants in the recirculating water. Sometimes a single pass of water may be used in the cooler.

### **Maintenance Modifications**

- Provide proper insulation on piping, chiller, or central storage tank.
- Regularly check equipment for leaks.
- Check to make sure that an excessive amount of water is not being bled-off.
- At least once a year, the recirculation pump and reservoir level should be checked for proper operation.

### **Retrofit Options**

- Add an *automatic control* to shut off the unit during unoccupied night or weekend hours.
- Install *pumps* to recirculate water through the cooler, reducing unnecessary consumption.



### **Replacement Options**

- Replacement options vary depending on the size of the facility and existing equipment. Consult with a manufacturer of evaporative cooling equipment for further assistance.

Boilers and steam generators are commonly used in large heating systems, in cooking, or in facilities where large amounts of processed steam are used. This equipment consumes varying amounts of water depending on the size of the system, the amount of steam used, and the amount condensate return.

Water management options for boilers and steam generators follow below:

### **Maintenance Modifications**

- Check steam traps and lines for leaks, which should be repaired as soon as possible.
- Provide proper insulation on piping, and on central storage tank.

### **Retrofit Options**

- Install a *condensate return system*. By recycling condensate for reuse, water supply and operating costs for this equipment can be reduced up to 70 percent. A condensate return system also helps to lower energy costs as the condensate water is already hot.
- Add an *automatic control* to shut off the unit during unoccupied night or weekend hours.

### **Replacement Options**

- Replacement options vary depending on the size of the facility and existing equipment. Consult with a contractor experienced in boilers/steam generators for further assistance.

# **LANDSCAPE IRRIGATION**

Water Management Options  
for Already-Established Areas

Xeriscaping

The previous sections of this chapter focused on the variety of water management options that help to reduce water consumption inside a building. In this section, outdoor water consumption, specifically as it applies to landscape irrigation, will be discussed.

This section will address landscape irrigation issues from two perspectives. First, we will outline operation, maintenance, and retrofit options for already-established landscaped areas.

Then, a detailed discussion of *xeriscaping* will be provided, outlining a comprehensive approach for planning and maintaining both existing and new low-water-demand landscapes.

## **Water Management Options for Already-Established Areas**

### **Operation Modifications**

The following simple modifications to the way you irrigate and maintain your grounds can produce significant water savings:

- Water only in the early morning to minimize evaporation. This simple change in your watering schedule will maximize the effectiveness of watering while minimizing the amount of water used.
- Water plant roots, not trunks and leaves. Plants need water at the roots for nourishment and growth. Topical watering results in evaporation and runoff. Adjust sprinklers to ensure that water is concentrated at the root area.
- Water deeply once a week instead of lightly every day.
- Keep your landscaped area weed-free so that valuable water is consumed only by the plants you want.
- Where possible, use recycled water for all decorative ponds, fountains, and waterfalls and shut them off whenever possible to reduce the amount of water lost to evaporation. (See Chapter 6 for a detailed discussion on recycling water.)
- Make sure sprinklers are placed so that they will water the landscape, not walks and parking lots. Decrease flow volumes to avoid unnecessary water runoff.

- Alternate your turf mowing height between low and high levels (see Step 4 in "Xeriscaping" for a detailed discussion).

### Maintenance Modifications

- Check water recirculation systems annually for leaks and other damage.
- Monitor sprinkler systems for broken or dirty heads.

### Retrofit Options

- Attach an inexpensive, water-efficient *nozzle or sprayer* if you currently water your facility's grounds using a hand-held hose. Numerous types are available, including bubblers, single-hole screw nozzles, gun nozzles, and watering wands. Additionally, thumb and gate control valves can also be attached to the hose to help reduce water use.
- Regulate when and how much water a sprinkler system distributes. An *irrigation timer* is a simple device that you can use to schedule sprinkler use during the off-peak, night, or early morning hours. Water rates are cheaper during this time, and in the absence of strong sunlight, the water used is less likely to evaporate.
- Use a *soil tensiometer* or an electronic sensor to help determine when the soil is dry, and gauge the amount of water needed.

If you are using a variety of automatic controls to time and regulate watering, make sure they have a manual override feature and that you use it. This way, if it rains, you can cancel your next watering. Alternately, use a soil tensiometer to automatically cancel waterings as necessary.

- Attach a *cathodic conditioner* to the sprinkler system's water supply to reduce the pressure of the water and the force of its spray. By reducing the surface tension of the water, between 25 and 50 percent less water is expended and wasted. A cathodic conditioner must be installed by a plumber, who inserts it either at the outside water supply if a mobile sprinkler is used or at the point where the pipes leave the building for sprinklers with underground pipes.
- Select drought-resistant trees, shrubs, and low-water-demand ground covering that consume less water than grass.

---

*There are two types of sensors that should be added to an automatic irrigation system: soil moisture sensors and rainfall sensors*

---

Figure 5-12. Subsurface Drip Irrigation System.

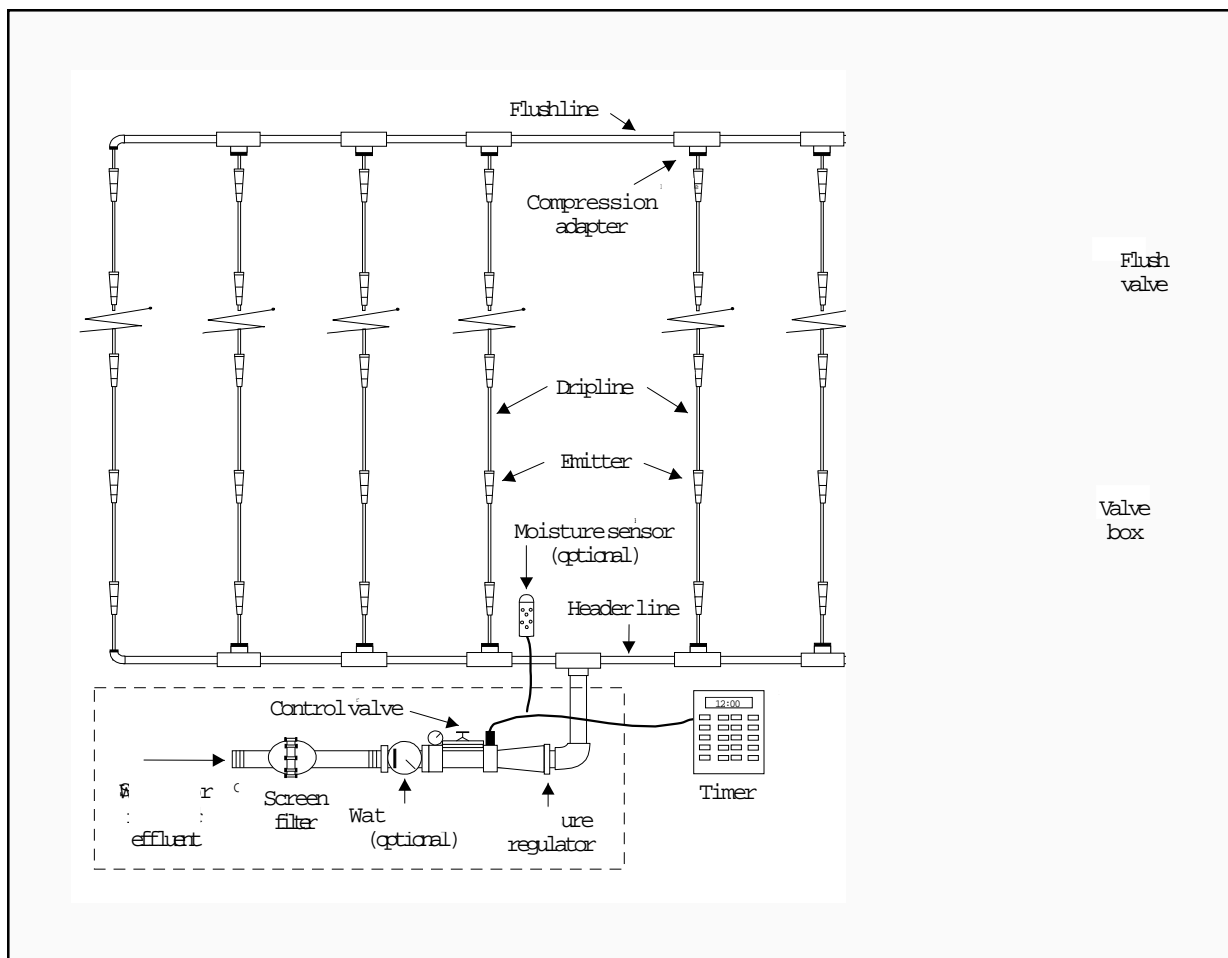

Source: Proposed Code Change to a Section and/or Sections of the UPC-USPC-OSEC, Submitted to the National Association of Plumbing and Mechanical Officials, Los Angeles, California, February 1992.

- Eliminate "strip grass" to the greatest extent possible. Small strips of grass, common in parking islands and between sidewalks and the roadway are hard to maintain and difficult to efficiently water, use bushes, colored tiles, instead.

**Replacement Options**

- Install an irrigation system that has controls or sensors.
- Use low-flow sprinkler heads instead of turf sprinklers in areas with plants, trees, and shrubs.
- Use a trickle or subsurface drip irrigation system (also known as a soaker hose) that is installed underground and

provides water directly to turf roots, preventing water loss by evaporation and runoff. (Figure 5-12 shows a subsurface drip irrigation system that uses graywater, as discussed in Chapter 6.)

## Xeriscaping

Xeriscaping is a comprehensive water management approach to landscaping that is based on selecting, placing, and maintaining plants that optimize water use. (The word xeriscaping is from the Greek "xeros," meaning dry.) Xeriscaping not only considers the types of plants, but also how they grow, are maintained, and how they interact with the climate and soil conditions.

For maximum water savings, implement all of the following seven steps of xeriscaping. However, implementing just one of the steps will still save water.

The seven steps are:

- Step 1: Practice good landscape design
- Step 2: Analyze and improve soil
- Step 3: Choose appropriate plants
- Step 4: Establish practical turf areas
- Step 5: Water efficiently
- Step 6: Use mulch
- Step 7: Practice appropriate maintenance

Figure 5-13 shows a typical xeriscaped landscape.

### Step 1: Practice Good Landscape Design

Good landscape design is the basis of xeriscaping. The first step is to analyze and prepare your site. Factors that will influence your landscape design include:

- Existing site characteristics that limit options, such as draining areas or pathways.
- Directional (north-south) orientation, which impacts sun exposure.

---

*Proper xeriscaping can reduce water use for landscape maintenance by as much as 50% and also reduce the amount of maintenance required*

---

Low Water  
Shrub Zone

Moderate Water  
Turf Zone

Figure 5-13. Typical Xeriscaped Landscape with Plants Grouped by Water Demand Category.

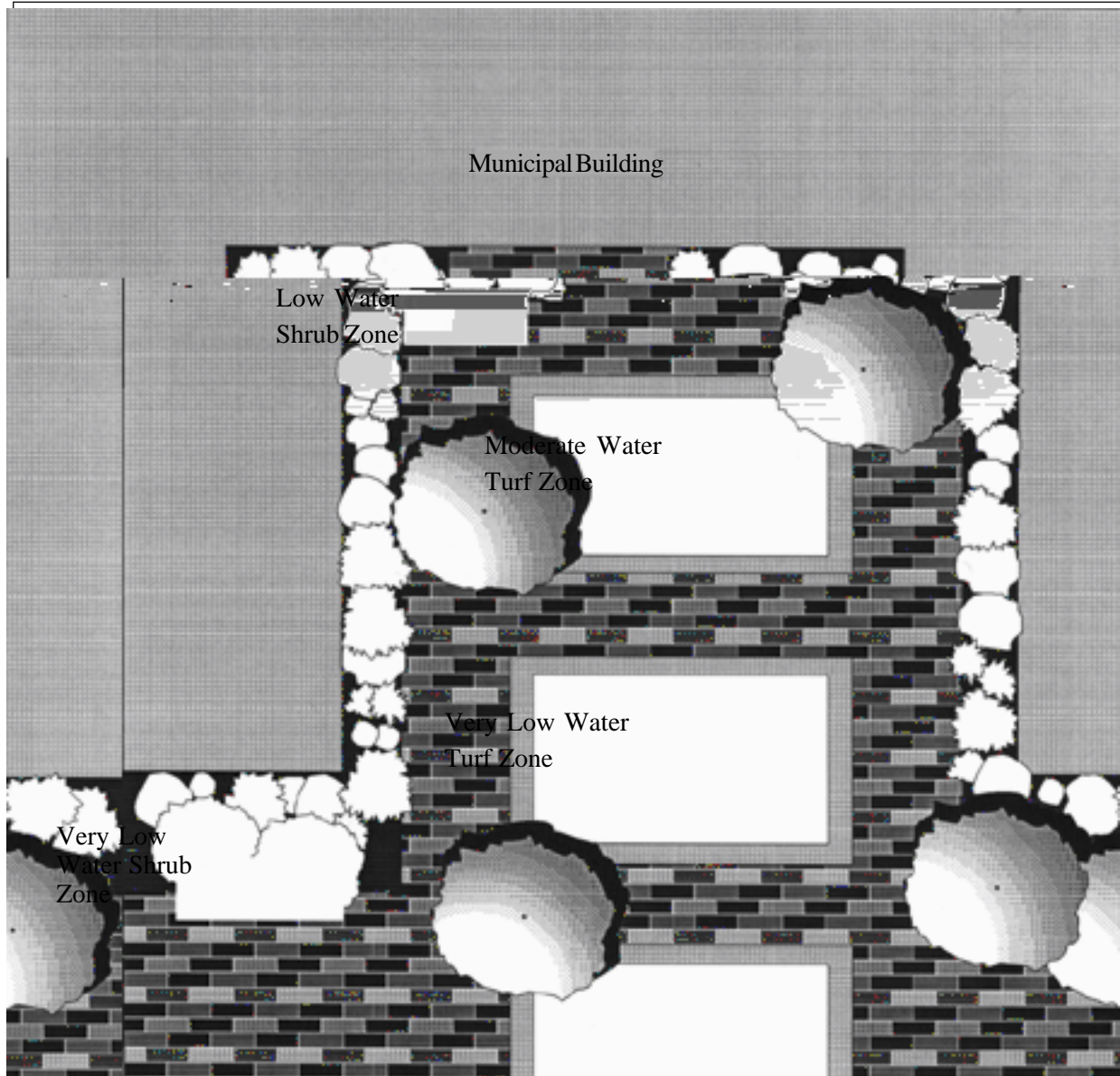

- Existing shade areas, which can be 20°F cooler than sunny spots.
- Limit turf and grass areas, which are very water-intensive, to only those areas that will be used for recreation and entertainment.

- Existing plants, trees, and shrubs—protecting existing foliage adds value to the site and also reduces landscaping costs when engaging in a new construction project.
- Large expanses of concrete and nonpermeable surfaces, which contribute to runoff. Alternatives such as gravel or permeable paving can prevent water from accumulating on sidewalks and in parking areas.

---

*Remember the "Golden Rule" of xeriscaping: Plants do not conserve water, people do*

---

## Step 2: Analyze and Improve Soil

- The quality of your soil will determine which plants will work in your landscape design. Your local county soil or agricultural extension office can analyze your soil and suggest ways to improve its ability to support plants and retain water.
- To protect your soil, never allow construction or other heavy trucks or machinery to park beneath trees, or allow dumping of trash, solvents, or debris containing toxics near trees.
- The seedbed (the first few inches of soil) is critical to water conservation. Make sure it is prepared properly (and modified if necessary) before planting: clean debris, add organic matter, improve its structure, and ensure proper drainage.

## Step 3: Choose Appropriate Plants

- Indigenous and native plants, once they are established (2 to 3 years), may require less water than those imported from other areas, and can more easily survive dry periods without any watering. Contact local nurseries or landscape professionals who advertise "native landscaping" services.
- Xeriscaping plants—ones that are low-maintenance, pest- and disease tolerant, and can survive with minimal water—can provide year-round color and require less fertilizer, pruning, and maintenance, saving your facility money, water, and labor. Many gardening centers now have special sections devoted to such plants.

---

*Tip: Exposed plumbing outlets such as spigots can freeze. Install self-draining or manually draining spigots to prevent this. You can also purchase long-stemmed yard hydrants, so the shutoff valve seat is well within the building, where it will not freeze.*

---



### When to Water

A simple change in your watering schedule may produce significant water savings, as proven by the City of Tampa, Florida, in a pilot project to assess the efficiency of existing landscapes and their irrigation systems. Twenty-five Tampa properties were chosen, 14 of which were commercial/business properties. The evaluation team found that the greatest potential for conservation, with the lowest associated cost, was to change the irrigation schedule. Recommendations given to property owners and operators included reducing run times for individual zones, eliminating some irrigation days (for example, cutting back from twice to once per week for acceptable zones), and incorporating seasonal irrigation cycles.

### Step 4: Establish Practical Turf Areas

Turf (or grass) is one of landscaping's biggest water consumers, yet serves as one of the best ways to reduce runoff and erosion and recharge groundwater. The type of turf, its placement, and how it is maintained can all dramatically affect water consumption.

Some guidelines include:

- Pick the turf that will work best. Consider shade, temperature, soil fertility, water use, and drought resistance when deciding which variety is best for your facility.
- Place turf where it will look best and be most functional. Limit its use, for example, to play or recreational areas and along walkways. Remember not to design turf spaces that are difficult to water or mow.

---

*Use low-angle sprinkler heads that produce droplets of water instead of a mist, and that do not spray the water high into the air.*

---

off the top of the grass to make it more stress tolerant. However, turf mowed at a constant height (always high or low) will actually require more water to preserve the turf and to reach the roots.

The best approach is to alternate the cut high and low. Mowing low will allow for less water usage, and mowing high will help to develop a deeper root system, and therefore, more drought-tolerant grass. This method of mowing may help reduce water use by as much as 30 percent, and will not dramatically impact clipping yields.

**Figure 5-14. Grass Root Growth Patterns.**

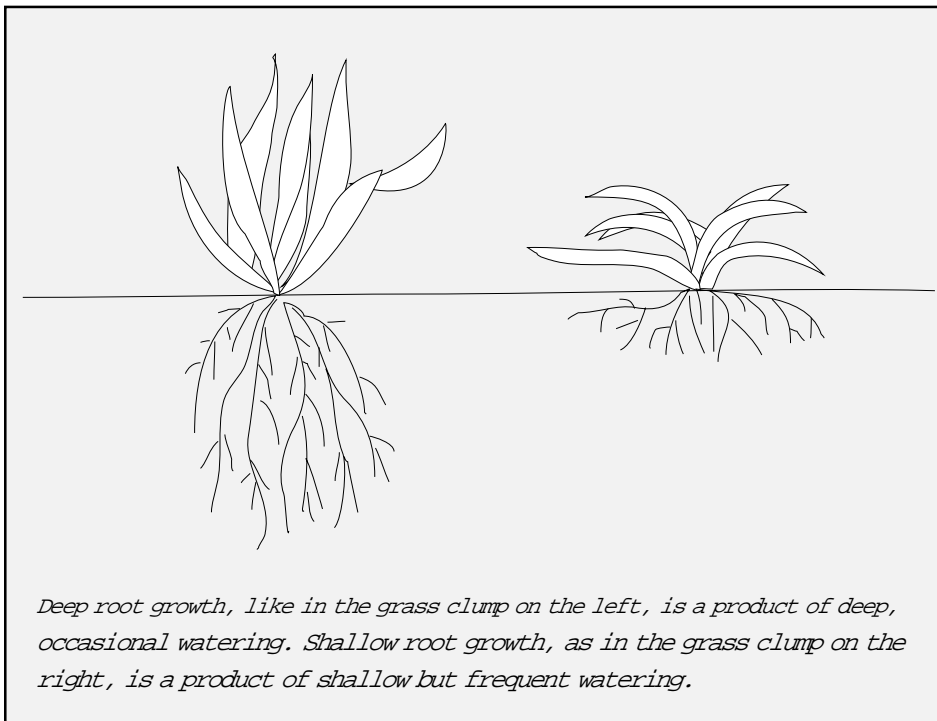

### Step 5: Water Efficiently

- Use automatic watering controls.
- Do not water excessively. Most lawns and plants require only about 1 inch of water a week during the growing season. Not only is excess watering a waste, the extra water undermines the effectiveness of fertilizers. Instead, water deeply once a week. (Figure 5-14).
- Group plants by "water-use zones" that combine high, moderate, and low-water-demand ground coverings and plants together. Water a specific type of plant only when needed.
- Water only in the early morning or nighttime, to avoid excess evaporation.
- Water turf with sprinklers. But, use low-angle sprinkler heads that produce droplets of water instead of a mist, and that do not spray the water high into the air.

- Water trees, shrubs, and flowers with low-volume drip, spray, or bubbler emitters. Drip systems in particular will eliminate wasteful runoff. When using drip irrigation systems, cover the hoses or tubes with mulch to control evaporation.
- Shape the soil into earthen basins around all shrubs and trees to promote water retention.

### **Step 6: Use Mulch**

- Mulch made out of fine-textured, organic, nonmatting materials such as assorted barks and leaves is one of the best ground coverings. It requires no water and little maintenance.
- Mulch placed around the bases of plants, trees, and shrubs will improve the soil, reduce water evaporation, encourage root growth, improve water penetration, and ultimately extend the time between waterings.

### **Step 7: Practice Appropriate Maintenance**

- Prune plants and trees only when necessary. Heavy pruning accelerates growth and increases their need for more water.
- Do not cut grass to less than one-third of its original height.

# 6

## ON-SITE WASTEWATER RECYCLING / RECLAIMED WATER

Traditionally, centralized municipal sewage treatment facilities have been the primary source of water disposal for government facilities. However, water shortages have heightened public concern about the availability of our water supply and have encouraged facility managers to seriously consider on-site recycling of the wastewater their buildings generate. In fact, on-site recycling can provide significant water savings in most types of buildings.

Additionally, facilities managers with buildings in areas with chronic water shortages should also check with their local wastewater utility to see if they have a program to provide reclaimed water to the building. (Reclaimed water is water from a wastewater treatment plant that is diverted to another use. Note that the use of reclaimed water may be restricted by local codes.)

---

*On-site wastewater recycling can provide significant water savings in most types of buildings*

---

### Current Practices

On-site wastewater recycling applications are currently found in states with persistent drought conditions. However, all arid, semiarid, and coastal areas that have experienced water shortages, as well as major urban areas where sewage treatment plants are overloaded and expansion is constrained, are potential candidates for on-site recycling.

Typically, wastewater that is recycled on-site is used for the following purposes:

- Flushwater for toilets and urinals
- Landscape irrigation

- Supply water for ornamental ponds
- Makeup water for cooling towers

## Types of Recycled Water

Water available for recycling falls into two broad categories: graywater and blackwater. *Graywater* is water that is generated by bathroom sinks, showers, and clothes washing machines. *Blackwater* is water flushed down toilets and urinals and water discharged from kitchen sinks that contains oil, fat, and grease.

The basic difference between graywater and blackwater is that graywater generally does not contain fecal matter and food waste, whereas blackwater does. Both graywater and blackwater can contain *pathogens* (disease-causing organisms).

For these reasons, blackwater and graywater must be treated before they are reused. At its most basic, treatment consists of removing suspended solids from the water. At its most sophisticated, treatment consists of biological treatment with membrane filtration, activated carbon, and ultraviolet light or ozone disinfection. Additionally, precautions must be taken to prevent humans and animals from coming into contact with potentially pathogen-containing water. These concerns, however, are relatively easy to address with an appropriate system and sensible practices.

## Basic Considerations

The use of on-site wastewater recycling systems should be considered when constructing new buildings. Even though many of these systems are costly to purchase, the payback period in savings from discharging less wastewater can be as little as 7 years.

## Types of Systems

The two basic on-site recycling systems are *graywater systems* and *combined wastewater treatment and recycling systems*. Both operate on the same basic principle—collecting and reusing water—and both have the same basic system components: piping, filter media, pumps, and storage units. Their differences mainly stem from the type of water they recycle, their degree of complexity, and the extent to which they treat

recycled water. Most graywater systems only filter graywater. In contrast, combined wastewater treatment and recycling systems filter and treat both graywater and blackwater.

### **Use of Reclaimed Water Saves 1.4 Million Gallons of Fresh Water at GSA Facility**

*"In 1991, over 5 million gallons of fresh water were used to irrigate the grounds, including trees and shrubs. After connecting to the City's reclaimed water in 1992, we reduced fresh water usage by about 1 million gallons, or 25.5 percent," commented James F. Bennett, GSA Field Office Manager. "Over \$4,000 was saved on water bills, too, by using the less expensive reclaimed water."*

The William C. Cramer Federal Building, a Federal office building operated by the General Services Administration (GSA) in Tampa, Florida, saved 1.4 million gallons of fresh water in fiscal year 1992. The building's irrigation system was connected to the City of St. Petersburg's reclaimed water lines. Businesses plagued by persistent drought conditions in southern Florida have been encouraged to use the City's reclaimed water, which costs significantly less than fresh water.

The eight-story Cramer Building houses about 900 employees. Built in 1967, it has more than 15,000 square feet of turf, including 17 trees and several hundred shrubs. The underground irrigation system includes 180 sprinkler heads that disperse water in various full-, half-, and quarter-arc patterns, depending on the landscape. Often, watering takes place twice a week and occurs before 9 A.M. or after 5 P.M.

"The connection of our irrigation system to the City's distribution lines was inexpensive and problem-free," Mr. Bennett added. "This project is the first of its kind in GSA Region 4. We hope that our success will impact the way water is considered in concept and design of future building projects by GSA engineers, staff, and other Federal agency personnel."

Prompted by this success, Mr. Bennett is planning to use reclaimed water in the building's cooling towers in the near future. The reclaimed water will replace freshwater supplies typically used for bleed-offs. He is also using other means to limit fresh water use by GSA facilities in his area. For example, Mr. Bennett is investigating the use of rainwater captured from the roof for irrigation at a courthouse building in Tampa.

In some areas of the country, it is also possible to purchase reclaimed water from a central municipal facility. Reclaimed water has been treated and recycled for all nonpotable use. This water is suitable for all graywater uses and is available at a significantly lower rate than potable water (refer to "Use of Reclaimed Water Saves 1.4 Million Gallons of Fresh Water at GSA Facility").

A detailed discussion of graywater and combined treatment recycling systems along with a description of a reclaimed water case study follows.

## Graywater Systems

Graywater is water that is generated by bathroom sinks, showers, and clothes washers. It usually does not include kitchen water, which may contain oil, fat, and grease. Graywater is recycled and used in many areas of the United States, both in residential and commercial applications, and most commonly for residential landscape irrigation. Graywater also can be used as flushwater for toilets and urinals.

In a graywater recycling system, water that normally would be discharged to a municipal sewage treatment plant is instead collected, treated to remove suspended solids and sludge, and reused. The basic steps in graywater recycling are as follows:

---

*Recycled graywater is most commonly used for residential landscape irrigation*

---

- Wastewater is collected from sinks, showers, washers, and the like.
- The water is piped to a treatment unit, which can be either physical (such as a filter), biological, or chemical.
- After filtration, the water is then stored and pumped to its ultimate end-use, such as irrigation, where it is regulated by a combination of valves and controls.

*Note:* Depending on the intended use of the graywater, it may also be treated and disinfected after filtration.

## System Components

Graywater systems range from simple, residential applications to complex, fully automated commercial and industrial systems. Regardless of their complexity, all graywater systems include most or all of the following elements:

- Storage tank(s) (typically made of fiberglass or industrial-strength plastic)

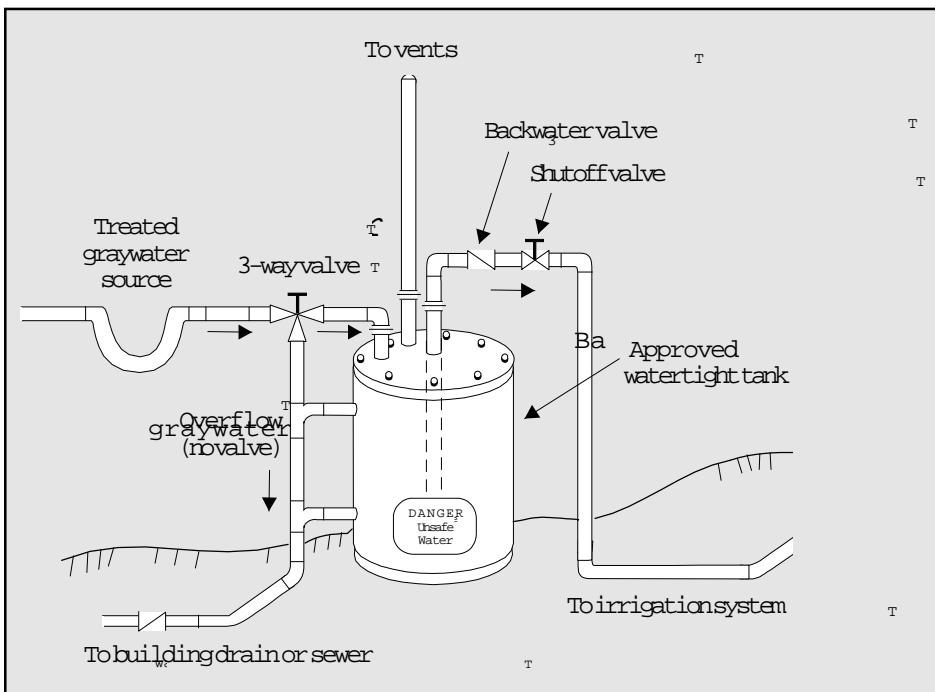
**Figure 6-1. Typical Graywater Piping and Distribution System.**

*Source: Proposed Code Change to a Section and/or Sections of the UPC-USPC-USBC, Submitted to the National Association of Plumbing and Mechanical Officials, Los Angeles, CA, February 1992.*

- Piping (color-coded PVC)
- Filters (polyester, cloth, and the like)
- Pump (fractional horsepower)
- Valves (three-way and check)
- Controls (manual or automatic)

Figure 6-1 is a schematic of a graywater piping and distribution system.

### Collection Methods

For buildings with slab foundations, recoverable graywater may be limited to washing machine discharge, because most drain pipes (such as for sinks) are buried beneath the slab and thus not easily accessible without a significant additional expense. However, buildings with perimeter foundations permit access to piping from crawl spaces, enabling recovery of most graywater sources.



## **Treatment Methods**

Graywater treatment methods include media filtration, collection and settling, biological treatment units, reverse osmosis, sedimentation/filtration, and physical/chemical treatment. Depending on the graywater source, application, recycling scheme, and economics, one method may be more appropriate than the other. These methods are discussed below.

### **Media Filtration**

Filters made of nylon, cloth, sand or rocks, and grates can all be used for graywater filtration. A nylon or cloth filter system consists of a filter bag connected to the graywater inlet pipe. The graywater is passed through the filter media, collected, and typically pumped to a mini-leach field (an underground gravel filter) for irrigation uses.

Some filters use a sand- and rock-filled tank. In these systems, graywater is poured onto splash plates, where it then seeps through the filter media. Bacteria growing on the sand break down the organic matter in the water and extract nutrients, which prevents further bacterial growth (bacteria need these nutrients to grow). Other types of filters used to treat graywater include filters that use pea-sized stones instead of sand; diatomaceous earth filters, which are commonly used to filter water for swimming pools and spas; and rack or grate filters, which can be used to remove particulate matter.

### **Collection and Settling**

Collection and settling systems employ techniques commonly used for treating combined graywater and blackwater. For example, one such system uses a septic tank. Solids from the incoming graywater settle to the bottom sludge layer and other materials, such as grease and hair, form an upper scum layer. The remaining effluent liquid then flows through an outlet pipe for further treatment.

### **Biological Treatment Units**

Biological treatment units usually comprise three chambers: presettling, aeration, and final settling (with sludge return). Graywater flows into the presettling chamber, where solids settle out. The remaining effluent then flows into the aeration chamber, where biological action reduces soluble organics. In the final settling chamber, biologically active solids settle out. These treatment units usually are used in large commercial applications.

**Reverse Osmosis**

Reverse osmosis units have been tested for graywater treatment. These systems comprise storage tanks, pumps, filtration units, and a reverse osmosis module. The water is collected and filtered, then pumped into the reverse osmosis unit.

**Sedimentation/Filtration**

There are a variety of sedimentation/filtration treatment systems, most of which have a conically shaped storage/settling tank and a filter. A variety of filters can be used, ranging from easily discarded cartridge filters, to diatomaceous earth filters, to activated charcoal filters.

**Physical/Chemical Treatment**

In physical/chemical treatment, graywater flows through a rapid mix tank, where polymer and activated carbon are added. The mixture of graywater, polymer, and carbon flows to a clarifier, where a sludge conditioner is added. After settling, the remaining water is disinfected and passed through a diatomaceous earth filter.

**Disinfection Techniques**

After graywater is treated, it may then also be disinfected. Four different disinfection techniques may be used to treat graywater for reuse within or outside buildings: ultraviolet irradiation, ozone, chlorine, and iodine. These four techniques are outlined below.

**Ultraviolet Irradiation**

Ultraviolet (UV) irradiation disinfection involves passing graywater under an ultraviolet lamp to kill microorganisms. For effective disinfection by UV, graywater must be free of particulate matter.

**Ozone**

Ozone is a highly reactive form of oxygen that is formed naturally when the sun's shortwave ultraviolet light reacts with oxygen in the upper atmosphere. Disinfecting graywater by exposing it to ozone is very safe and can destroy algae, bacteria, and viruses and oxidize most organic and inorganic contaminants. While ozone in large doses can be harmful to humans, a well-designed ozone system for graywater disinfection poses no harmful or irritating problems.

**Chlorine**

Chlorine tablets are the most commonly used method of graywater disinfection in residential applications. Bacterial reductions occur after about 30 minutes of exposure to the chlorine.

---

*All graywater outlets  
must be clearly  
labeled to state that  
they dispense  
nonpotable water*

---

### **Iodine**

Iodine crystal units operate in the same manner as chlorine tablets. However, because of iodine's limited solubility, a dosing pump is required to ensure adequate pressure and flow of wastewater for the iodine crystals to dissolve.

### **Storage**

After treatment, graywater can be stored for no more than 48 hours. Water that cannot be used by this time must be discharged to the municipal sewer system.

---

*Installing a graywater system requires the retrofitting of existing plumbing, and all alterations to the plumbing system must be approved by local authorities.*

---

### **Installation Considerations**

Graywater systems must be installed in accordance with local plumbing codes and by professional, licensed plumbing contractors. Installing a graywater system requires the retrofitting of existing plumbing, and all alterations to the plumbing system must be approved by local authorities.

All counties and cities that permit graywater recycling require building inspectors to inspect sites and, after the installation, verify compliance and proper operation of the graywater system.

Local authorities may require that graywater supply systems be clearly distinguished from potable (drinking) water supplies. Methods of doing so may include extensive labeling of the system or the use of different piping materials for the different systems—for example copper type "1" for the potable system and PVC for the graywater system. All graywater outlets must be clearly labeled to indicate that they dispense nonpotable water. Local codes also may require marking graywater supplies by adding biodegradable dye. Additionally, backflow preventers also must be installed to ensure the proper separation of potable water and graywater supply systems.

### **Operation and Maintenance Considerations**

The pathogenic organisms in graywater must not come into contact with either humans or animals. There are several precautions to ensure this does not happen. First, either treat the water to eliminate pathogens or avoid their introduction into water by not mixing graywater with any source water that could contain fecal matter. Second, prevent human exposure to the graywater by not collecting or storing it in an open container.

Graywater used for irrigation should not be applied directly through a spraying device, but rather injected directly into the soil through *drip irrigation*. Drip irrigation allows you to receive the benefits of using recycled water and at the same time avoid contaminating animals, humans, and edible plants.

It is also important to make sure that cleaning products found in the graywater do not contain chemical levels that could poison plants or damage soil through the buildup of inorganic salts. Biodegradable cleaners that contain no sodium, chlorine, or boron can be safely used with graywater systems and are commercially available.

Rain or excessive irrigation could cause ground saturation and result in pools of graywater on the surface. To help eliminate this situation, turn off the graywater system and divert the graywater to the sanitary sewer line during rainy periods.

A maintenance program for a graywater system must include the following steps, all of which must be performed regularly:

- Inspecting the system for leaks and blockages
- Cleaning and replacing the filter bimonthly
- Replacing the disinfectant
- Ensuring that controls operate properly
- Periodically flushing the entire system

## Combined Wastewater Treatment and Recycling Systems

Combined wastewater treatment and recycling systems differ from graywater recycling systems in that they collect and treat *all* wastewater—that is, both graywater and blackwater. These systems have many significant advantages over conventional wastewater treatment and disposal systems, both from water and wastewater management perspectives. Although the initial costs of combined wastewater treatment and recycling systems currently are not cost-competitive with using an on-site septic tank/leach field or discharging wastewater into public sewer systems, the ultimate savings from reduced water consumption and wastewater discharge can be significant. Furthermore, there are many sites that currently cannot be developed but could be through the use of a combined wastewater treatment and recycling system. These sites include the following:

---

*Many sites that currently cannot be developed could be developed through the use of a combined wastewater treatment and recycling system*

---

**Figure 6-2. Combined Wastewater Treatment and Recycling System for a Commercial and Industrial Building.**

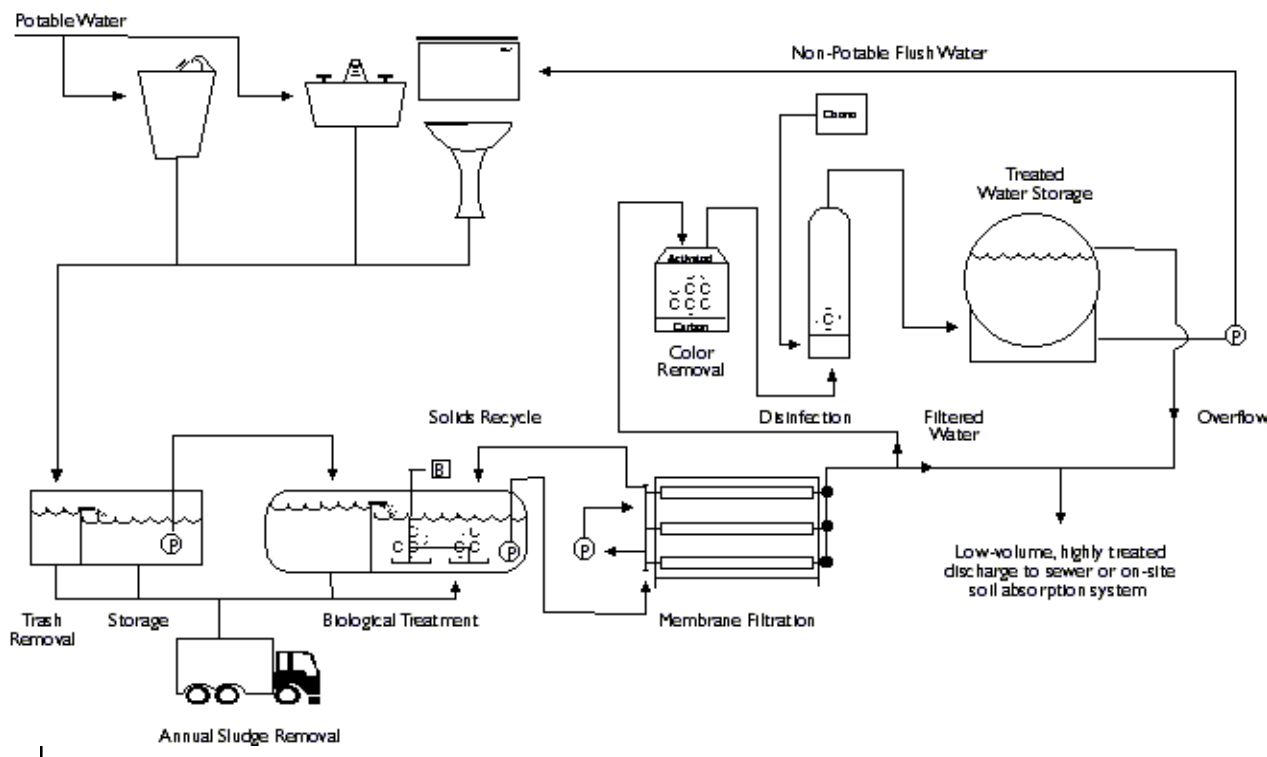

Source: Thetford Corporation (Cycle-Let model).

- Sites that cannot be served by a public sewer or are currently under a sewer moratorium.
- Areas in which on-site problems prohibit the use of a large sanitary leach field.
- Sites where conventional on-site treatment is a problem because of poor soil, high groundwater, wetlands, or concerns about groundwater contamination.
- Areas where water conservation is a primary consideration.

Currently, combined wastewater treatment and recycling systems are commercially available from only a few companies, some of which also manufacture and distribute graywater systems.

Of the approximately 100 combined wastewater treatment and recycling systems currently in use in commercial buildings, most recycle the treated wastewater for toilet and urinal flushing. Other end-

uses include landscape irrigation and supply water for ornamental ponds.

### Basic System Components

The major components of combined wastewater treatment and recycling systems include collection and storage tanks, piping, filter media, pumps, and controls. Depending upon the application involved, controls are usually more complex and, in most cases, microprocessor-based. Figure 6-2 is a schematic of a typical combined wastewater treatment and recycling system for commercial and industrial buildings.

As in graywater systems, there are a variety of ways to treat water in combined wastewater treatment and recycling systems, including aerobic treatment, collection, settling and sand filtration, and biological treatment with filtration and disinfection.

In an aerobic system, an aerobic biological treatment process oxidizes and removes soluble or fine, suspended materials. This system provides the compartmentation, hydraulic flows, and the oxygen necessary to optimize the aerobic process. In this system, usually no additional chemicals are required.

Collection, settling, and sand filtration systems use septic tanks to collect the combined wastewater from the building. The wastewater is then pumped to the sand filter to remove suspended materials.

The most sophisticated systems incorporate biological treatment with membrane filtration, activated carbon, and ultraviolet light or ozone disinfection. In these systems, sludge accumulates in a trash trap or in a biological treatment unit, which is typically housed in the basement of the building it serves or in a separate outbuilding.

### Application Considerations

When designing a combined wastewater treatment and recycling system, it is important to consider not only how much wastewater the facility produces, and therefore how much wastewater will need to be treated, but also how much of this recycled wastewater the facility will actually *need*. It commonly is assumed that 50 percent of the occupants are men and 50 percent are women. Women use a toilet 100 percent of the time and studies have shown that men use the toilet 24 percent of the time and the urinal 76 percent of the time. The total sanitary facility

---

*Combined systems have many significant advantages over conventional wastewater treatment and disposal systems*

---

<sup>4</sup>Enviro-Management & Research, Inc., and the National Association of Plumbing-Heating-Cooling Contractors, *Assessment of On-Site Graywater and Combined Wastewater Treatment and Recycling Systems* (Washington, D.C.: Environmental Protection Agency, 1992).

use over an eight-hour period is three uses per person per day. In addition, lavatory sink use is estimated at 0.25 gallons per toilet or urinal use. The contribution to flow from urination adds approximately 0.07 gallons per day (gpd) per fixture use. It is important to remember that because recycled water must not be stored for more than 48 hours before use or discharge to the municipal sewer, the size of your system and water storage tanks must be tailored to the actual amount of recycled water needed.

### Operation and Maintenance Considerations

One of the major obstacles to the widespread approach and acceptance of combined wastewater treatment and recycling systems is that regulatory agencies are concerned about the systems' operational and maintenance reliability. To address these concerns, most manufacturers of these systems have developed computerized monitoring and control systems that provide remote monitoring and alarm capability for a constant daily surveillance of each system. Manufacturers also offer (either directly or through authorized distributors) annual service contracts to ensure reliable operation of the equipment and controls. These precautions make the systems very reliable.

### Cost

The installed cost of combined wastewater treatment and recycling systems varies with the system size and capacity. Prices can range from \$70,000 for a unit that serves 100 people to \$450,000 for a unit serving 2,500. Because the relative cost of this equipment can remain high compared to decreased water costs, building owners usually lease, rather than purchase, such systems.<sup>1</sup>

---

*The use of recycled water in California increased 30% in 1998.*

---

### Reclaimed Water

Reclaimed water is water from a wastewater treatment plant that is diverted to another use, often for irrigation and fire prevention. Several states, most notably California, Texas, and Florida, are committed to increasing the use of reclaimed water in the face of ongoing water shortages (the use of recycled water in California increased 30% in 1998). Reclaimed water can often be significantly cheaper than potable water. For example, in Jupiter, Florida, reclaimed water costs 26 cents for 1,000 gallons, compared to \$1.70 for 1,000 gallons of potable water (Source: *Greening Federal Facilities*, Sustainable Systems, Inc.)

But if you have buildings in a area with chronic water shortages, check with your local wastewater utility and ask if they have a program to provide reclaimed water to your building's location. If your building already has an onsite wastewater treatment plant, it might be a good idea the feasibility of modifying it to reclaimed water for applications that do not require potable water, including the following:

- Landscaping
- Golf courses
- Fountains
- Irrigation
- Cooling tower makeup
- Boiler feed
- Once-through cooling

### **Reclaimed Water Increases Reservoir Yield**

The Upper Occoquan Sewage Authority Regional Water Reclamation Plant discharges to the Occoquan Reservoir, a principal water supply source for approximately one million people in Northern Virginia. The UOSA Plant was created originally to eliminate pollution of the Occoquan Reservoir by several small sewage plants. However, because of very reliable, state-of-the-art performance and the high-quality water produced, regulatory authorities endorsed UOSA expansion to increase the safe yield of the reservoir. The initial capacity of 10 mgd has been expanded to 32 mgd, and a \$200 million expansion to 54 mgd is in progress. UOSA reclaimed water is now an integral part of the water supply plans for the Washington metropolitan area.

The Water Reclamation Plant includes conventional primary-secondary treatment, high pH chemical treatment, and two-stage recarbonation with intermediate settling, multimedia filtration, carbon absorption, ion exchange, and breakpoint chlorination. Key permit parameters include: 0.5 NTU turbidity, 1.0 mg/L suspended solids, 10 mg/L COD, 1.0 mg/L nitrogen, 0.1 mg/L phosphorus, and 0.1 mg/L MBAS. For additional information, call Millard H. Robbins, Jr., at 703-830-2200.

Source: WaterWiser webpage.



- Concrete mixing
- Fire main water

### **Requirements for a Successful Reclaimed Water Project**

For a reclaimed water project to be successful, make sure one or more of the following conditions are met :

- The cost of water is high
- There is a lack of a high-quality freshwater supply
- There are local policies that encourage the use of reclaimed water, or water conservation
- There is high-quality effluent available
- Reuse is the most cost-effective way to dispose of wastewater effluent

### **Operating Considerations**

- Reclaimed water pipes must be color coded with purple tags or tape according to standards set by the American Water Works Association to minimize cross-connection problems.
- Signs should be used liberally to indicate that reclaimed water is nonpotable. Place them in public places (eg, in front of a fountain), and on valves, meters, and fixtures.
- Keep the pressure of reclaimed water 10 psi lower than potable water mains to prevent backflow and siphonage in case of accidental cross-connection.
- Run reclaimed water mains at least 12 inches lower in elevation than potable water mains, and horizontally at least 5 feet away.
- Review the quality of reclaimed water to ensure there will be no harmful effects, such as salt buildup, from long-term use.

### **Rainwater Harvesting**

Although the advent of large, reliable community water treatment and distribution systems has almost made the practice of rainwater harvesting a forgotten one, several states, such as Hawaii and Texas, have active rainwater harvesting programs. Additionally, the entire country of Australia practices rainwater harvesting, and commercial buildings

in Hong Kong collect and store rainwater to supply their water requirements.

For facilities managers, rainwater can be collected in cisterns and used with little or no treatment for a variety of nonpotable purposes. However, it should be noted that rainwater systems can often require a large investment and significant modification, and are not always cost-effective in existing buildings. Buildings with crawlspaces are much easier to retrofit than slab-on-grade construction, where the piping runs under the slab.

### **System Components**

Following are the major components of a rainwater harvesting system:

- Catchment Area/Roof (surface upon which the rain falls)
- Gutters/Downspouts (to carry the water to storage)
- Leaf Screens (to remove debris)
- Cisterns/Storage Tanks (to store the harvested rainwater)
- Conveyances (to deliver the stored water, either by gravity or pump)
- Water Treatment System (to settle, filter, and disinfect)

### **How Much Can You Collect?**

According to *The Texas Guide to Rainwater Harvesting* (Texas Water Development Board), you can collect 600 gallons of water per inch rain per 1,000 square feet of catchment area. To determine how much water you could collect in a year, perform the following:

1. Calculate the roof catchment area
2. Multiply the collection area in square feet by 0.6 gallons per square foot per inch of rain times the collection factor (which measures your collection efficiency; 80%, or 0.8, would be a good efficiency) times the average annual rainfall
3. Divide this figure by 365, and that will give you your daily collection figure.

# 7

## **YOUR WATER MANAGEMENT TOOLKIT: FINANCIAL AND TECHNICAL RESOURCES**

This chapter provides some useful resources that will help you design and implement your water management plan. It includes a description of available financing options; an overview of the Federal Energy Management Program; a list of internet-based resources on water management; tips on selecting a contractor; and a description of energy-savings performance contracts.

### **Financing Options**

#### **Energy Savings Performance Contracts (formerly called shared water savings contracts)**

Federal agencies are permitted to enter into multiyear energy-savings performance contracts, subject to certain specified requirements. Under such contracts, private firms may pay to install energy-saving equipment in Federal buildings in return for a share of the future energy cost savings. DOE is currently developing a similar program for water savings. Because of the average low cost of water in many regions, however, this practice may not become widespread.

#### **Federal Procurement Challenge**

The Federal Procurement Challenge is a voluntary governmentwide program that harnesses the collective buying power of the Federal Government to provide leadership in energy-efficient purchasing. Its goal is to help Federal facilities meet mandatory water- and energy-

conservation requirements. (For more information on the Procurement Challenge, see Chapter 6.)

### **The New Technology Demonstration Program**

The New Technology Demonstration Program was established by the U.S. Department of Energy in 1990 as a means to reduce Federal-sector energy costs and improve overall energy efficiency. The Program introduces new energy-efficient technologies to the Federal sector more quickly, narrowing the gap between private-sector and Federal deployment rates of new technologies. The Program uses two strategies: technology demonstrations, in which technologies are installed and evaluated at a Federal facility, and information dissemination through Federal Technology Alerts. The Program is cooperatively managed through an Interlaboratory Council of four national laboratories.

### **Special OMB Fund (under consideration)**

Under Executive Order 13123, the Office of Management and Budget shall explore the feasibility of establishing a fund that agencies could draw on to leverage exemplary energy management activities and investments with higher initial costs but lower life-cycle costs.

### **Federal Appropriations and Grants**

Federal agencies will be eligible to receive competitive grants from the U.S. Department of Energy (DOE) to help them meet the energy and water efficiency requirements in response to the passage of the Energy Policy Act.

### **Federal Incentives**

Half of any energy and water conservation savings, including the benefits from performance contracts as well as incentives from utilities, are to remain available to the Federal agency for additional efficiency measures, including employee incentive programs. The GSA Federal Buildings Fund also may receive cash incentives related to energy savings and recycling. DOE is to establish a financial bonus program, awarding a total of up to \$250,000 per year for outstanding energy managers in agencies.

### **Utility, Municipal, and Other Incentives**

Federal agencies are permitted and encouraged to participate in utility incentive programs for gas, electricity, and water conservation, and to negotiate incentives with utilities. Incentives may include free building

water surveys, equipment design, installation, and tenant education program assistance.

## **The Federal Energy Management Program**

The mission of the Federal Energy Management Program (FEMP) is to reduce the cost of Government by advancing energy efficiency, water conservation, and the use of solar and other renewable energy. FEMP's activities have helped to reduce the Federal government's energy consumption by 23.4% since 1985, measured on a Btu-per-gross-square-foot basis.

FEMP, which is administered by the U.S. Department of Energy, accomplishes its mission by creating partnerships, leveraging resources, transferring technology, and providing training and support. FEMP is also responsible for managing the overall energy- and water-conservation programs mandated by Executive Order 13123, "Greening the Government Through Efficient Energy Management," which was signed by President Clinton on June 3, 1999. In short, FEMP works with Federal agencies to help achieve Federal energy- and water-conservation goals.

FEMP also provides a variety of support to Federal facility managers. This support includes the following:

- **Project Assistance.** FEMP can help plan and develop site-specific water conservation projects. To assist in this process, FEMP has developed WATERGY, a spreadsheet modeling program that estimates potential water savings.
- **Training and Workshops.** FEMP offers a Water Resource Management training course, and, for a fee, will design and implement agency-specific water-conservation workshops.
- **Project Financing Assistance.** The FEMP Water Conservation Program supports Federal use of alternative financing mechanisms such as energy savings performance contracting and utility contracts for water conservation.
- **Federal Water Working Group.** FEMP facilitates this group, which focuses on increasing awareness of water management, technical assistance, training, water-conservation planning, and partnerships with industry and professional associations.

## Internet Resources for Water Management

- FEMP (Federal Energy Management Program)  
<http://www.eren.doe.gov/femp>
- NIST Office of Applied Economics  
<http://www.bfrl.nist.gov/oe/oe.html>
- American Water Works Association:  
<http://www.awwa.org>
- WaterWiser: The water efficiency clearinghouse  
<http://www.waterwiser.org>
- Facilities Net (online access to several building-maintenance/energy-efficiency-related magazines)  
<http://www.facilitiesnet.com>
- American Society of Plumbing Engineers  
<http://www.aspe.org>
- Green Seal  
<http://www.greenseal.org>
- The Plumbing Web  
<http://www.plumbingweb.com>
- Plumbing, Heating, and Cooling Contractors Association  
<http://www.phcca.org>
- Plumbing Manufacturer's Institute  
<http://www.pmihome.org>
- National Drought Mitigation Center  
<http://enso.unl.edu/ndmc>
- Federal Energy Management Program  
<http://www.eren.doe.gov/femp>
- Water Reuse Association of California  
<http://www.watereuse.org/h2o>
- United States Geological Survey

<http://usgs-georef.cos.com>

■ Water Online

<http://www.wateronline.com>

■ US Water News

<http://www.uswaternews.com>

■ Institute for Water Resources, Army Corps of Engineers

<http://www.wrsc.usace.army.mil/iwr/>

## Tips on Selecting a Contractor

When making the decision to hire a contractor to help with your water management program, keep the following in mind:

- Does the contractor have all of the appropriate licenses to do the work?
- Does the contractor have previous experience both in the area in which you seek expertise and in working with a facility similar to yours in size and function?
- Is the contractor a team player? Can this person cooperate with others of different specialties?
- Does the contractor have a solid reputation and references from prior clients? (You should specifically ask for references from organizations with facilities similar to yours and from those who had similar work performed; you will want to ask these references if the work was performed on schedule, within budget, and as promised.)
- Is the contractor affiliated with a professional trade association? Does the trade association have any comments or complaints about the contractor?

Finally, as with all people you interview for a project, you will want to select the best person for the job—the contractor who offers you the most competitive overall package, including labor rate, product recommendations, experience, warranty for work, skill and craftsmanship level, and commitment to quality.

## Energy-Savings Performance Contracts

According to the Federal Energy Management Program, more than \$4 billion is available from the private sector through energy savings performance contracts (ESPCs), which were authorized by the Energy Policy Act of 1992. An ESPC, formerly known as Shared Energy Savings Contracting, is an alternative to the traditional method of financing energy efficiency improvements in Federal buildings (that is, Federal appropriation of capital funds). Under an energy savings performance contract, Federal agencies contract with energy service companies, which pay all the up-front costs. These costs include identifying building energy requirements and acquiring, installing, operating, and maintaining the energy-efficient equipment. In exchange, the contractor receives a share of the cost savings resulting from these improvements until the contract period expires, which can be up to 25 years. At that time, the Federal government retains all the savings and equipment. FEMP assists agencies in choosing and implementing projects through their partnerships with the private sector.

The key benefits of an ESPC are that it:

- Reduces energy costs
- Improves Federal energy efficiency and helps meet the Federal energy savings requirements
- Eliminates the maintenance and repair costs of aging or obsolete energy-consuming equipment
- Places the operations and maintenance responsibilities on the contractor
- Stimulates the economy by allowing energy service companies to profit from their up-front investments in federally owned buildings by receiving a share of the utility bill savings.

The contractor also provides for training government personnel and measuring energy savings. Several Federal agencies have successfully awarded these unique contracts.



## **"Super" ESPCs**

FEMP developed streamlined Super ESPCs to make ESPCs easier to use. This type of contract is based on the indefinite delivery, indefinite quantity provision of the Federal Acquisition Regulation. Super ESPCs are either regional or technology-specific contracts that allow agencies to negotiate site-specific ESPCs, or delivery orders, with an energy service company without having to start the contracting process from scratch. In this way, agencies can "piggyback" their own ESPC projects onto a broader Super ESPC, saving time, energy, and money.

There are also Technology-Specific Super ESPCs. Unlike Regional Super ESPCs, Technology-Specific Super ESPCs blanket the entire Nation, so any Federal agency can contract with the preselected energy service companies (ESCOs) for services for any facility in the country. Rather than applying to a specific geographic region, a particular energy-efficient or renewable energy technology is emphasized in these contracts.

## **Energy Cost Savings**

Energy cost savings refer to a reduction in the cost of energy used in Federally owned buildings. The contract sets forth the methodology for establishing the base cost and the share of energy cost savings each year. The contract also specifies the method of determining the value of such savings, which may vary from year to year.

Energy cost savings may result from the lease or purchase of operating equipment, improvements, altered operations and maintenance, or technical services. Savings may also result from using cogeneration or heat recovery to improve the efficiency of existing energy sources.

Because ESPCs depend on proper measurement and verification of promised energy savings, FEMP supported the development of a collaborative effort to produce a consensus document for measuring and verifying energy savings that Federal energy managers, procurement officials, and private sector energy services providers could use. DOE developed the North American Measurement and Verification Protocol and as the first application, FEMP issued the Measurement and Verification Guideline for Federal Energy

Projects. The new FEMP guideline speaks the Federal language and provides standard procedures for quantifying savings from the installation of energy conservation measures. Intended for use in ESP contracts, the FEMP guideline provides the methodology for establishing cost savings called for in the ESPC regulation.

### **When Can ESPC Be Used?**

ESPC allows Federal agencies to update aging building systems, streamline operations, and train maintenance workers to reduce operating costs. ESPC can be used when:

- Updating aging equipment with newer, more efficient products
- Helping agencies meet the energy cost reduction goals of Executive Order 13123 and EPAct
- Conserving nonrenewable fuels and achieving environmental benefits by reducing energy consumption
- Reducing utility costs without sacrificing service.

Agencies can use future energy savings to fund projects, freeing up money currently wasted on energy inefficiency and making it available for facility improvements and sustained maintenance.

### **Assistance Available**

FEMP has developed model procurement documents; the Measurement and Verification Guideline for Federal Energy Projects; a how-to manual for ESPCs; a home page on the Internet; and educational videos for management, legal, and contracting personnel. In addition, FEMP is developing training videos to assist agency personnel in preparing site-specific ESPCs. Also available on videotape is a May 1996 TeleFEMP satellite broadcast of a panel discussion on ESPC and other alternative financing approaches. All videotapes are available through the FEMP Help Desk.

To help streamline the contracting process, DOE issued a solicitation for its first FEMP Energy Savings Performance Contract. DOE plans to issue several Super ESPCs that will cover the remainder of its six regions. There are also plans to issue Super ESPCs for specific energy conservation technologies. The streamlined process allows Federal agencies to issue orders off of each contract and begin to realize energy

cost savings more quickly. Demands on agency resources to develop contracts should be reduced, allowing agencies to use their valuable and scarce resources on other priorities.

FEMP offers agencies two workshops on ESPCs. The first workshop provides agencies with the information they need to participate in a Super ESPC. The second workshop is customized to assist agencies in preparing their own site-specific project, preparing an agency Super ESPC, or reviewing other alternative financing options. The workshops are targeted to Federal employees who want to learn how to execute successful energy projects using any ESPC approach. Participants should be from any of the engineering, operations, contracts, legal, or budget organizations of those facilities that can benefit from energy conservation retrofits. Maximum benefit can be attained if technical and contracting personnel attend the workshops.

### **Life-Cycle Cost Analysis and ESPCs**

The general principles of life-cycle cost analysis (LCCA) can be used to evaluate Energy Savings Performance Contracts. LCCA can be used to compare the costs of the existing equipment over a given time period with the costs over the same time period of a project proposed by an Energy Service Company (ESCO) or utility. The costs of performing a feasibility study, setting up and administering the contract, and financing the project through the ESCO or utility can all be included in the LCCA. The building life-cycle cost (BLCC) software program, in addition to the detailed LCC report showing lowest LCC, also prints out a listing of undiscounted year-to-year cash flows, which allow the analyst to determine whether the total cost savings or energy-related savings of the project are sufficient to cover the proposed contract payments. LCCA also allows the analyst to compare the life-cycle costs of financed Energy Conservation Measures (ECMs) with those of agency-funded ECMs, the latter implemented either immediately or in a future year.

When evaluating ESPCs or UCs, using the BLCC program, some additional input data and assumptions are needed, such as the investment amounts to be financed, contract payments, contract term, and the borrowing rate. Additionally, the following assumptions must be incorporated: base date and service date; current-dollar analysis; and the cost of feasibility studies and "sunk costs."

Table 7-1. Federal Water-Use Indices

Category	User	(Gallons/unit/per day)		
		Unit	Range	Typical
Commercial				
	Airport	Passenger	4-5	3
	Apartment house	Person	100-200	100
	Boardinghouse	Person	25-50	40
	Hotel	Guest	40-60	50
		Employee	8-13	10
	Lodginghouse and tourist home	Guest	30-50	40
	Motel	Guest	25-40	35
	Motel with kitchen	Guest	25-60	40
	Laundry (self-service)	Machine	400-650	550
	Office	Employee	8-20	15
	Public Lavatory	User	3-6	5
	Restaurant (including toilet)			
	Conventional	Customer	8-10	9
	Short-order	Customer	3-8	8
	Shopping center	Parking Space	1-3	2
		Employee	8-13	10
	Open Space			
	Non-turf	Acre		785
	Turf	Acre		1571
Recreational				
	Apt., resort	Person	50-70	60
	Bowling alley	Alley	150-250	200
	Camp			
	Pioneer type	Person	15-30	25
	with toilet/bath	Person	35-50	45
	Day, with meals	Person	10-20	15
	Day, w/out meals	Person	8-18	13
	Trailer	Trailer	75-150	125
	Campground	Person	20-40	30
	Country club			
		Members	80-125	100
		Employee	10-15	50
	Dormitory (bunkhouse)	Person	20-45	35
	Fairground	Visitor	1-2	3

**Table 7-1. Federal Water-Use Indices (continued)**

Category	User	(Gallons/unit/per day)		
		Unit	Range	Typical
Institutional	Picnicpark w/flushtoilets	Visitor	5-10	6
	Swimmingpool w/beach	Customer	5-15	10
	Visitorcenter	Employee	8-15	10
		Visitor	4-8	5
	Assemblyhall	Seat	2-4	3
	Hospital, medical	Bed	130-250	150
		Employee	5-15	10
	Hospital, mental	Bed	80-150	120
		Employee	5-15	10
	Prison	Inmate	80-150	120
		Employee	5-15	90
	Rest home	Resident	5-120	90
		Employee	5-15	10
	School day w/caf., gym, showers	Student	15-30	25
	cafeteriaonly	Student	10-20	15
	w/out caf., gym	Student	5-15	10
	School, boarding	Student	50-100	75

**Table 7-2. Volume and Metric Conversions**

---

<b>Volume conversions</b>		
1gallon(gal)	=	8.34pounds
1cubicfoot (ft <sup>3</sup> )	=	7.48gallons
1unit (Ccf)	=	748gallons
1acre-foot (AF')	=	325,851gallons
1acre-foot (AF')	=	43,560cubicfeet
1milliongallons/day (MGD)	=	1121acrefeet/year
<b>Metric conversions</b>		
1acre	=	.4hectares
1gallon	=	3.8liters
1cubicfoot	=	0.03cubicmeters

---

# GLOSSARY

**Aerator:** a device installed in a faucet or showerhead that adds air to the water flow, thereby maintaining an effective water spray while reducing overall water consumption.

**Aerobic Treatment:** a biological treatment used to oxidize and remove soluble or fine materials.

**Blackwater:** water discharged from toilets, urinals, and kitchen sinks.

**BLCC:** Building Life-Cycle Costing.

**Bleed-Off:** the release of built-up solids in a cooling tower by removing a portion of the recirculating water that carries the dissolved solids.

**Cathodic Conditioner:** a device attached to a sprinkler that lowers the surface tension of the water flow, which saves 25 to 50 percent of the water used in irrigation.

**Combined Wastewater:** a facility's total wastewater, both graywater and blackwater.

**Condensate:** water used in a boiler or steamer that has not evaporated.

**Cooling Tower:** equipment that uses water to regulate air temperature in a facility by either rejecting heat from air-conditioning systems or by cooling down hot equipment.

**Cutoff Control Valve:** a retrofit device for faucet or shower fixtures that enables the user to shut off existing waterflow (for example, while shampooing), and restart it at the previous temperature.

**Cycles of Concentration:** number of times water is used in a cooling tower before it is discharged as bleed-off.

**Declining Block Rate:** a fee structure whereby the price per unit decreases as consumption increases.

**Diatomaceous:** consisting of or abounding in diatoms or their siliceous remains. Diatoms are minute planktonic algae; diatomaceous earth is often used as a filtering agent.

**Displacement Devices:** toilet retrofit devices, including dams, bags, bottles, and the like, designed to displace tank water, thereby reducing the water consumption of each flush.

**Drip Irrigation:** a watering method typically using a water pipe or hose with small, evenly spaced holes, which evenly and slowly deliver water directly to turf and landscape roots.

**Dual Flush Adapter/Device:** a retrofit device designed to adapt a toilet to dual flush, where the first flush uses only a portion of the tank water to remove solid wastes and the second, smaller, flush uses the remaining water to remove liquid wastes and paper.

**Early Closure Device:** a toilet device that closes the tank flapper early during the flushing cycle, thereby using less water with each flush.

**Evaporation:** the act of water or other liquids dissipating or becoming vapor or steam.

**Faucet Aerator:** either a device inserted into a faucet head or a type of faucet head that reduces faucet water consumption by adding air to the water.

**Faucet Restrictor:** a device inserted in a faucet head behind its particle trap screen that reduces waterflow by forcing water through a opening smaller than that of the original head.

**Flat Rate Fee:** a fee structure in which the price of water per unit is constant, regardless of consumption.

**Flow Restrictors:** washerlike disks that fit inside faucet or shower heads to restrict waterflow.

**Flushometer Valve Toilet:** also known as a flushometer toilet, a tankless toilet with the flush valve attached to a pressurized water supply pipe. When activated, the connecting pipe supplies the water to the toilet at a flow rate necessary to flush waste into the sewer.

**Graduated Rate:** a fee structure whereby the price per unit of water increases as consumption increases.

**Gravity Flush Toilet:** a toilet designed with a rubber stopper that releases water from the toilet's tank, after which gravity often forces the water, which collects the waste, into the bowl and through a trap.

**Graywater:** used water discharged by sinks, showers, bathtubs, clothes washing machines, and the like.

**Irrigation Timer:** a device that can be manually scheduled to regulate when and how much water a facility's landscape receives.

**Life-Cycle Cost Analysis:** a process of evaluating the total purchase and operating cost of a water efficiency option (that is, retrofit, replacement, and



the like) that considers the cost over the life of the system versus solely the initial cost of the system or equipment.

**Low-Flow Toilet:** a toilet that uses 3.5 gallons of water per flush.

**Meter:** a device installed by a water utility to measure a facility's water consumption.

**Ozonation:** a chemical process that uses ozone to cleanse a cooling tower of microbes and other foreign matter.

**Potable Water:** clean, drinkable water; also known as "white" water.

**Pressurized Tank Toilet:** a toilet that utilizes a facility's waterline pressure by pressurizing water held in a vessel within the tank, compressing a pocket of trapped air. The water releases at a force 500 times greater than a conventional gravity toilet.

**Pressurized Reduction Valve:** a valve designed to reduce a facility's water consumption by lowering water pressure per square foot (requires utility installation).

**Pulsaters:** a shower or faucet head attachment (retrofit) that conserves water by varying the water spray pattern from the head with alternate strong and light flows.

**Retrofit:** changing, altering, or adjusting plumbing fixtures to save water or make them operate more efficiently.

**Self-Closing Faucet:** a faucet that automatically cuts off waterflow after a designated amount of time (usually a few seconds).

**Sensor:** a device that controls waterflow through detection. Sensors, typically either electronic motion-detecting or ultrasound, detect motion to automatically start waterflow and turn it off.

**Sidestream Filtration System:** rapid sand or high-efficiency cartridges that draw water from a basin, filter out sediment, and return the filtered water to the cooling tower, enabling the system to operate more efficiently while using less water.

**Siphonic Jet Urinal:** a urinal that automatically flushes when water, which flows continuously to its tank, reaches a specified preset level.

**Soil Tensiometer:** a device that measures ground moisture content to control sprinklers or other outdoor watering devices.

**Source Meter:** a water meter that records the total waterflow into a facility.  
*See also Submeter.*

**Submeter:** a water meter that records water use by a specific process or building within a larger facility. *See also Source Meter.*

**Sulfuric Acid Treatment:** a treatment that lowers the pH in cooling tower water by converting a portion of the calcium bicarbonate to the more soluble

calcium sulfate, which controls scale or mineral buildup and allows the cooling tower water to operate more efficiently.

**Toilet Dam:** a flexible insert placed across the inside of a toilet tank that holds back water when the toilet is operated, lowering the water consumed with each flush. *See also Displacement Devices.*

**Ultra-Low Flow Toilet:** a toilet that uses 1.6 gallons or less of water per flush.

**Water Audit:** a building- or facilitywide assessment of water use.

**Water Balance Diagram:** a diagram that tracks water flow through a building or facility; total water inflows in the diagram equal total outflow plus water lost through consumption, irrigation, and evaporation.

**Xeriscaping:** the selection, placement, and care of water-conserving and low-water-demand ground covering, plants, shrubs, and trees in landscaping.

## REFERENCES

American Society of Sanitary Engineering. *Energy & Water Conservation Guidelines*. Cleveland, OH: American Society of Sanitary Engineering, 1987.

American Water Works Association. *Proceedings of Conserv 93—the New Water Agenda (Sessions W3-1 through 4A-6)*. Denver, CO: American Water Works Association, 1993.

American Water Works Association. *Proceedings of Conserv 93—the New Water Agenda (Sessions 4B-1 through 7C-3)*. Denver, CO: American Water Works Association, 1993.

American Water Works Association. *Water Audits and Leak Detection*. Denver, CO: American Water Works Association, 1990.

American Water Works Association. *The Water Conservation Manager's Guide to Residential Retrofit*. Denver, CO: American Water Works Association, 1993.

American Water Works Association. *Xeriscape Programs for Water Utilities*. Denver, CO: American Water Works Association.

Anderson, Beauford. "Commercial and Industrial Program Case Studies." *Proceedings of Conserv 93: The New Water Agenda*, Paper # 2A-3. Las Vegas, NV: 1993.

Arnold, Marilyn, and Don Gray. *Water Efficiency in Federal Facilities and Programs*. Washington, DC: Environmental and Energy Study Institute, 1993.

Baumann, Daune D., and Eva M. Opitz. "Measurement of Conservation Attitudes and Behaviors: Trends in Southern California." *Proceedings of Conserv 93: The New Water Agenda*, Paper # 4B-1. Las Vegas, NV: 1993.

- Black and Veatch. *A Guide to Commercial/Industrial Water Conservation*. Los Angeles, CA: City of Los Angeles Department of Water and Power.
- Black and Veatch. *A Guide to Water Conservation for Cooling Towers*. Los Angeles, CA: City of Los Angeles Department of Water and Power, 1991.
- Building Officials and Code Administrators. *BOCA National Plumbing Code/1987*, 7th ed. IL: Building Officials and Code Administrators, International, Inc., 1986.
- Chaplin, Scott W. "Alternative Supplies: Rainwater Collection Systems, Graywater Systems, and Composting Toilets." *Proceedings of Conserv 93: The New Water Agenda*, Paper # 6C-3. Las Vegas, NV: 1993.
- Chicago Plumbing-Heating-Cooling Information Bureau. *Innovations in Plumbing Products Promote Comfort, Safety, and Water Conservation*. Chicago, IL: Chicago Plumbing-Heating-Cooling Information Bureau, 1992.
- Chicago Plumbing-Heating-Cooling Information Bureau. "On-Site Water Recycling: Water Wave of the Future?" Chicago, IL: Chicago Plumbing-Heating-Cooling Information Bureau, 1991.
- Chicago Plumbing-Heating-Cooling Information Bureau. "Old Toilets 'Hit the Road' In Recycling Programs." Chicago, IL: Chicago Plumbing-Heating-Cooling Information Bureau, 1991.
- Cities of Chandler, Glendale, Goodyear, Mesa, Peoria, Phoenix, Scottsdale, and Tempe. *Xeriscape: Water Conservation through Creative Landscaping*. AZ: The cities of Chandler, Glendale, Goodyear, Mesa, Peoria, Phoenix, Scottsdale, and Tempe.
- City of San Jose, Brown and Caldwell Consultants, and California Department of Water Resources. *Case Studies of Industrial Water Conservation in the San Jose Area*. CA: City of San Jose, Brown and Caldwell Consultants, and California Department of Water Resources, 1990.
- Colorado Utilities Department, City of Aurora. *Landscaping for Water Conservation: XERISCAPE!*. Aurora, CO: City of Aurora and Denver Water Department, 1989.
- Enviro-Management & Research, Inc., and the National Association of Plumbing-Heating-Cooling Contractors. *Assessment of On-Site Graywater and Combined Wastewater Treatment and Recycling Systems*. Washington, DC: Environmental Protection Agency, 1992.
- Enviro-Management & Research, Inc., and the National Association of Plumbing-Heating-Cooling Contractors. *Water Manage 1: Economic Analysis Software*

- for Wastewater Recycling and Management*. Washington, DC: Environmental Protection Agency, 1993.
- Environmental Protection Agency, Office of Water. *Xeriscape Landscaping: Preventing Pollution and Using Resources Efficiently*. Washington, DC: Environmental Protection Agency, Office of Water, 1993. [EPA-840-B-93-001]
- Farwell, Larry. "Graywater: A Secure Future for Landscapes?" *Proceedings of Conserv 93: The New Water Agenda*, Paper # 5B-3. Las Vegas, NV: 1993.
- Freifelder, Rachel. "Stretching the Drops: Making a Little Water Go a Long Way." *Home Energy* (July/August 1988): 14-22.
- Gall, Bruce, Gilles Patry, and Ray Rivers. "Effects of Water Conservation on Wastewater Treatment Plant Performance." *Proceedings of Conserv 93: The New Water Agenda*, Paper # 2D-3. Las Vegas, NV: 1993.
- General Services Administration. *Energy and Water Management*. Washington, DC: General Services Administration, 1983.
- Horton, Charles. "Not So Fast On 1.6 gpf Closets!" *Supply House Times* (November 1988).
- "How to Save Water." *Consumer Reports* (July 1990): 465-473.
- Inlow, Allen R. "Plumbing Steps That Save Water." *Journal of Property Management* (September/October 1992): 35-36.
- Kobrick, J. Douglas. "Nonresidential Water Conservation Programs and Examples." *Proceedings of Conserv 93: The New Water Agenda*, Paper # 2A-1. Las Vegas, NV: 1993.
- Lance, Susan, and Theodore B. Shelton. *Designing a Water Conservation Program--An Annotated Bibliography of Source Materials*, Washington, DC: Environmental Protection Agency, Office of Water, 1993. [832-B-93-003]
- Lant, Christopher L., and John H. Sims. "Social Ideologies of Urban Water Conservation." *Proceedings of Conserv 93: The New Water Agenda*, Paper # 4B-4. Las Vegas, NV: 1993.
- Lowe, Carl. "Water-Saving Toilets." *Home Energy* (July/August 1988): 34-35.
- Maddaus, William O. *Water Conservation*. Denver, CO: American Water Works Association, 1987.
- McCune, Heather. "Water: Is There Enough?" *Plumbing and Mechanical* (March 1993): 56-59.
- Nelson, John O. "Water Conserving Landscapes Show Impressive Savings." Presented at American Water Works Association Annual Conference and Exposition, Denver CO, June 24, 1986.

- Nero, Wendy L., and Betsy G. Davis. "Landscape Water Audit and Improvement Program: Motivating Outdoor Conservation." *Proceedings of Conserv 93: The New Water Agenda*, Paper # 6B-8. Las Vegas, NV: 1993.
- O'Grady, Kevin, and Jeff DeWitt. "Long-Term Monitoring of Conservation Attitudes and Behavior in the Phoenix Metropolitan Area." *Proceedings of Conserv 93: The New Water Agenda*, Paper # 4B-2. Las Vegas, NV: 1993.
- Petrovic, A. Martin, and Beatrice B. Baikan. "Water Conservation in Turfgrass: Mowing and Fertilization Effects." *Proceedings of Conserv 93: The New Water Agenda*, Paper # 4A-6. Las Vegas, NV: 1993.
- Planning and Management Consultants, Ltd. *Municipal and Industrial Water Use in the Metropolitan Water District Service Area: Interim Report No. 4*. Carbondale, IL: Planning and Management Consultants, Ltd., 1991.
- Ploeser, Jane H. "Marketing Non-Residential Conservation." *Proceedings of Conserv 93: The New Water Agenda*, Paper # 4B-5. Las Vegas, NV: 1993.
- The Resources Agency. *Water Efficiency Guide for Business Managers and Facility Engineers*. CA: The Resources Agency, Department of Water Resources, Division of Local Assistance, 1993.
- "Saving Water Heating Energy." *Energy Auditor & Retrofitter* (January/February 1985): 9-13.
- Shamsi, Uzair M. "Water Conservation Through Preventive Maintenance."
- Sheikh, Bahman. "The City of Los Angeles Gray Water Pilot Project: Gray Water is as Safe as Low-Voltage Electricity." *Proceedings of Conserv 93: The New Water Agenda*, Paper # 2D-7. Las Vegas, NV: 1993.
- Small Flows Clearinghouse. "Alternative Toilets Replace Very Low-Flush Toilets--WVKBKGN09." Morgantown, WV: Small Flows Clearinghouse, West Virginia University, 1993.
- Solley, Wayne B., and Robert R. Pierce. "Effects of Water Conservation and Other Factors on Water Use in the United States." *Proceedings of Conserv 93: The New Water Agenda*, Paper # 2B-1. Las Vegas, NV: 1993.
- South Florida Water Management District. *Xeriscape*. FL: South Florida Water Management District.
- South Florida Water Management District. *Xeriscape Plant Guide II*. FL: South Florida Water Management District.
- Texas Agricultural Extension Service. *Landscape Water Conservation. . . Xeriscape*. College Station, TX: Texas Agricultural Extension Service, 1988. [Publication # B-1584]
- Tilden, B.O. "The Evolution of the Water Closet." *NE Progress* (January 1989): 10-12.

The University of Georgia. *Xeriscape—A Guide to Developing a Water-Wise Landscape*. Athens, GA: Cooperative Extension Service, The University of Georgia College of Agricultural and Environmental Sciences, 1992.

University of Wisconsin. *Water Heating and Water Conservation*. Institutional Buildings Program, Bonneville Power Administration, Contract # DE-AC79-82BP31302 by the Board of Regents of the University of Wisconsin System, University Extension Department of Engineering.

Vickers, Amy. "Water-Saving Showerheads and Faucets." (October/November 1993): 82-84.

Wilcox, Kevin. "Alternative Toilets: To Flush, or Not To Flush." *Small Flows* (April 1993): 6-7.





# APPENDIX A. FEDERAL, STATE, AND COMMUNITY WATER CONSUMPTION STANDARDS

The Energy Policy Act of 1992 set Federal water consumption standards for plumbing fixtures manufactured after January 1, 1994, but in addition, many states and communities have also adopted water consumption standards for buildings within their boundaries. These standards may be more stringent than Federal standards set by the Energy Policy Act. Seventeen states and numerous local communities had adopted water conservation legislation, and 3 other states had water conservation legislation pending before the Energy Policy Act of 1992 was even signed. Many of these states and communities began their water conservation practices in the 1980s, the earliest of which was Goleta, California, in 1983. Facilities should conform to both Federal and local water conservation standards.

These states and communities established their water conservation legislation and incorporated water-efficiency plumbing-fixture standards in their plumbing and building codes for many different reasons, including the following:

- To preserve and protect their water sources, both surface and groundwater
- To ensure water availability for all beneficial uses
- To reduce water and energy costs
- To regulate the plumbing and fixture trade
- To protect health and the environment

Above all, these states and communities recognize the value of water as a precious resource. Table A-1 shows Federal, state, and community water conservation standards.

**Table A-1. Federal (Energy Policy Act of 1992), State, and Community Water Conservation Standards.**

Jurisdiction	Effective Date	Toilets <sup>a</sup> (gpf)	Urinals (gpf)	Showerheads (gpm)	Lavatory Faucets (gpm)	Kitchen Faucets (gpm)
Federal (Energy Policy Act)	1/1/94	1.6	1.0	2.5 @ 80 psi	2.5 @ 80 psi	2.5 @ 80 psi
Arizona	1/1/93	1.6	1.0	2.5 @ 80 psi	2.0 @ 80 psi	2.5 @ 80 psi
California	1/1/92	1.6	1.0	2.5 @ 80 psi	2.2 @ 60 psi <sup>c</sup>	2.2 @ 60 psi <sup>c</sup>
California, Goleta	1983	1.6	1.0	2.0 @ 80 psi	2.0 @ 80 psi	2.0 @ 80 psi
Florida, Tampa	6/1/90	1.6	1.0	2.5 @ 80 psi	2.0 @ 80 psi	2.0 @ 80 psi
Georgia						
Residential	4/1/92			2.5 @ 60 psi <sup>b</sup>		
Commercial	7/1/92	1.6	1.0	2.5 @ 60 psi <sup>b</sup>	2.0	2.0 @ 80 psi
Maryland, Aberdeen	3/30/90	1.6	1.0	2.5 @ 80 psi	2.0 @ 80 psi	2.0 @ 80 psi
Maryland						
Calvert County	6/3/86	1.5	1.0	2.5 @ 80 psi	@ 80 psi	2.0 @ 80 psi
New York	1/1/90	1.5	1.0	2.5 @ 80 psi	2.0	2.0 @ 80 psi
Rhode Island	9/1/90	1.5	1.0	2.5 @ 80 psi	2.0 @ 80 psi	2.0 @ 80 psi
Texas	1/1/92	1.5	1.0	2.5 @ 80 psi	2.2 @ 60 psi <sup>c</sup>	2.2 @ 60 psi <sup>c</sup>
District of Columbia	1/1/92	1.5	1.0	2.5 @ 80 psi	2.0 @ 80 psi	2.2 @ 60 psi <sup>c</sup>

gpf = gallons per flush  
gpm = gallons per minute  
psi = pounds per square inch

Sources: Adapted from information provided by the Portland, Oregon, Bureau of Water Works; Amy Vickers and Associates; the National Wildlife Foundation; and Wade Miller Associates, Inc.

<sup>a</sup>The maximum water use allowed for any *gravity tank-type* white, 2-piece toilet which bears an adhesive label conspicuous upon installation consisting of the words "Commercial Use Only" manufactured after January 1, 1994, and before January 1, 1997, is 3.5 gallons per flush. The maximum water use allowed for *flushometer valve toilets*, other than blowout toilets, manufactured after January 1, 1997, is 1.6 gallons per flush.

<sup>b</sup>2.5 gpm is equivalent to 2.9 gpm at 80 psi when measured at a test pressure of 60 psi.

<sup>c</sup>2.2 gpm is equivalent to 2.5 gpm at 80 psi when measured at a test pressure of 60 psi.

# APPENDIX B. WORKSHEETS

Worksheet 1. Sample Building Water Survey Form

**Worksheet 1. Sample Building Water Survey Form**

Surveyed by:

Date:

**General Information**

Name of building:

Address:

Building contact:

Phone number:

Building dimensions:

Building wastewater is currently:

Is recycled water currently used in any of the following areas?

Width

Treated on-site

Toilets

Length

Connected to city water system

Urinals

Other

Cooling Towers

Irrigation

Number of floors (height):

**Building Occupancy Data**

Average number of occupants:

Number of women:

Number of men:

**Occupancy Schedule**

Week days

From

a.m.

To

p.m.

Saturdays

From

a.m.

To

p.m.

Sundays

From

a.m.

To

p.m.

Holidays

From

a.m.

To

p.m.

**Worksheet 2. Existing Plumbing Equipment**

**Worksheet 2. Existing Plumbing Equipment**

Use Area	Flo No.	Equipment	Number of Units	Typ	Mounting (floor/wa	Make and Model	Average Flow Rate or Consumpti (gpf)	Averag Uses per Week per Unit	Comments (leaks, controls, etc.)
Men's bathroom		Showerheads							
		Sinks (faucets)							
		Urinals							
		Toilets							
Women's bathroom		Showerheads							
		Sinks (faucets)							
		Toilets							
Cleaning (faucets)		Mop, sink, other							
Drinking fountain									
Irrigation		Drip irrigation							
		Sprinklers							
Kitchens		Sinks (faucets)							
		Dishwasher							

gpf=gallons per flush

### Worksheet 3. Cooling Tower Water Survey Checklist

Worksheet 3. Cooling Tower Water Survey Checklist								
Tower Number	Serving	Capacity	Manufacture and Model Number	Type	Average Make-Up Water (gpm/day)	Type of Chemical Treatment (if any)	Current pH level	Comments (leaks, valve problems, etc.)

gpm = gallons per minute

### Worksheet 4. Boiler Water Survey Checklist

Worksheet 4. Boiler Water Survey Checklist											
Boiler Number	Location	Type (steam/h water)	Capacity (mbh)	Manufacturer and Model Number	Operating Pressure (psig)	Hot Water Temperature		Hot Water Flow (gpm)	Steam Pressure (psig)	Fuel Type (gas/oil)	Comments (leaks, water treatment, etc.)
						Supply	Return				

gpm = gallons per minute; mbh = British thermal units per hour (thousands); psig = pounds per square inch gauge

**Worksheet 5. Irrigation Water Survey Form**

<b>Worksheet 5. Irrigation Water Survey Form</b>								
Type	Number of Hours Used per Day	Number of Units	Type	Mounting	Make and Model	Average Flow Rate	Average Uses	Comments
Drip irrigation								Flow Restrictors Used? Yes ___ No ___
Sprinklers								Adjustable Water Pressure? Yes ___ No ___
Other								
<b>Other Pertinent Information</b>								
Timers used on sprinklers? Yes ___ No ___								
If yes, then indicate timing cycle								
Morning: From ___ a.m. To ___ a.m.								
Evening: From ___ p.m. To ___ p.m.								
Any visible leaks? Yes ___ No ___								
Description								
Condition of irrigation equipment: Good ___ Worn ___								
Description								
Special equipment (soil tensiometer, etc.)? Yes ___ No ___								
Description								





## APPENDIX C. SAMPLE LETTER TO BUILDING OCCUPANTS

As you implement your facility's water management program (Step 6), you will also want to recognize your facility's employees as an integral part of the campaign to save water and money.

Following is a sample letter that, as a facility manager, you would send to building occupants once you have determined your water management program. Ideally, your building's employees will already be aware of the water management program, as you would have alerted them—and sought their input—during various stages of the comprehensive facility audit (for example, in evaluating hours of equipment use and by whom). You may want to send the letter with the signature of your agency's director to indicate this program has the enthusiastic support of top management. And to make sure everyone in the facility receives the letter, talk to payroll staff about including it in paycheck envelopes.

In keeping with a comprehensive approach to water management, you probably recognize that a letter alone is not sufficient. You will also want to post signs in restrooms and kitchens, alerting users that a water management program is in place. Particularly in the case of new equipment, be sure to post signs indicating how the equipment has been changed and how users should use it. With sensors on sinks, for example, indicate that anything within view of the sensor's eye will cause the water to flow. Tell visitors how they are activated and why they were installed. It might also be of interest to users to know exactly how much water they are saving: perhaps an occasional sign showing that the third floor ladies room, for example, has saved 25 gallons a day compared to last year at this time, for a cumulative total of 1 million gallons in water savings and a specific amount in utility savings. Involving facility users helps to keep consciousness raised and ensures the program's success.

---

*The following sample  
letter will help  
recognize facility  
employees as integral  
to the water  
management program*

---

Date

Dear occupant:

In keeping with recent legislation requiring Federal facilities to conserve water, \_\_\_\_\_ will be implementing a water management program over the next \_\_\_\_\_.

*name of facility*

*length of time*

As part of our water management program, we need \_\_\_\_\_ occupants to do their part. As you have in the past, we want you to continue to let building operation or maintenance staff know if you see a problem such as a leaking faucet, running toilet, or sprinklers watering the sidewalk. Most of the time, you are the water users in \_\_\_\_\_, and we count on you to let us know when there is a problem.

*name of facility*

In addition to maintenance, \_\_\_\_\_ has initiated the following water management improvements, which will save us *x* percent in water consumption:

*name of facility*

- Toilets have been modified so that the flush can operate on two levels. The flush back—the big flush—is for waste disposal, while the forward flush is for liquids. Both flushes use considerably less water because we have modified the toilet's tank so less water comes in and out.

The toilet modifications above will not give us the savings we would realize with new, ultra-efficient toilets. They will, however, help us to begin saving water and money, and our budget for 1996 includes funding for new toilets throughout the building (where cost-effective). All toilets now made must be ultra-low flow, so our new fixtures will save the maximum amount possible.

Signs have been posted on toilet stall doors alerting individuals as to the proper way to flush. Please let building management know if the signs are down for any reason. Please

also spread the word among \_\_\_\_\_ visitors that we have a water manage-  
*name of facility*  
 ment program in place.

- Faucets have been adjusted and the water flow reduced. You will still have enough water to wash your hands, but the overall process should use less water.

Especially on the first floor, where we have a large number of visitors, we are currently exploring conversion of our manual faucets to fixtures that respond to sensors. Through either infrared or ultrasonic sensors, the devices would detect the presence of an individual's hands below the faucet, and water would flow accordingly. When the hands are removed, the water automatically shuts off.

- Outside, on \_\_\_\_\_ grounds, we are approaching spring and our traditional  
*name of facility*  
 "planting" season a little differently. By adhering to the principles of xeriscaping—the selection and placement of plants to optimize water use—we can save 30 to 80 percent of our landscape irrigation cost. Our front walk will still be colorful this summer, but the plants we choose will meet a new, drought-tolerant criteria. And you will gradually see us moving away from a broad lawn to a more landscaped area, as our program evolves.

Our long-term water management goal is to make efficient use of water throughout the \_\_\_\_\_ building. We are moving in that direction through the modifications  
*name of facility*  
 made to our toilets and faucets and through a change in \_\_\_\_\_ 's landscape.  
*name of facility*

But just as important as the changes we make is the commitment to water management by \_\_\_\_\_ 's occupants. Without our employees playing an active role in con-  
*name of facility*  
 serving water, our efforts alone will not be enough. Please take a moment to give us your thoughts and suggestions on saving water. The most creative suggestions will be featured in a new water column in \_\_\_\_\_ 's newsletter.  
*name of facility*

With thanks,

Name

Director of Operations

p.s. To report leaks or other water problems, call my office at 555-1111.