



# Basic Aviation Safety

May 2013



**Office of Aviation Services  
300 E. Mallard Drive, Suite 200  
Boise, Idaho 83706**

**Designed and produced February 1990  
Revised June 2012, May 2013**

**Additional copies of this publication may be  
downloaded from [www.iat.gov](http://www.iat.gov)**

---

## **May 2013 Revision Note**

The May 2013 revision is an interim revision to provide personnel engaged in aviation operations with corrected information on helicopter crash positions.

This revision replaces information on helicopter crash positions (page 16) with the May 22, 2013 Interagency Aviation Safety Alert No. IA SA 13-01. The Safety Alert is included at the back of this publication.

This is the only information revised from the June 2012 edition.

---

---

This page intentionally blank.

---

# BASIC AVIATION SAFETY

## Contents

Helicopter Safety.....	1
Safety around Helicopters .....	2-4
Helicopter Capabilities and Limitations .....	5-11
Personal Protective Equipment.....	12-16
Airplane Safety .....	17
Airplane Capabilities and Limitations.....	18-21
Skiplane, Seaplane, and Floatplane Safety.....	22-24
Flying in Remote Locations.....	25
Emergency Locator Transmitter (ELT) .....	26-27
Helicopter Hand Signals .....	28



# HELICOPTER SAFETY

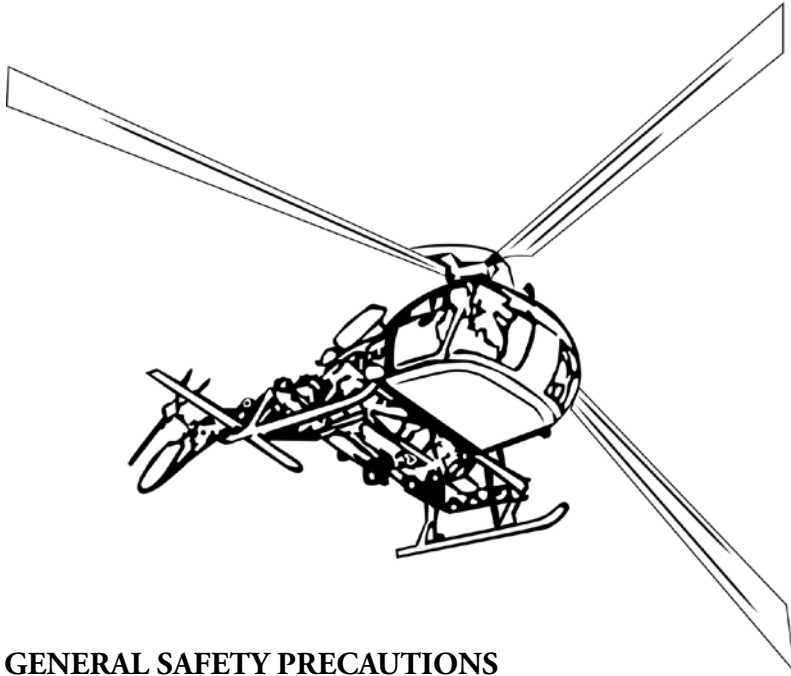

## GENERAL SAFETY PRECAUTIONS

- Comply with the applicable general safety rules for operations and practices prescribed in the Basic Aviation Safety (BAS) booklet and Federal, State and Operational Safety and Health Administration (OSHA) standards.
- Check pilot and aircraft data cards upon arrival and prior to flight.
- The pilot is responsible for the safety of the aircraft and passengers at all times.
- Request a briefing from the pilot concerning safety features of the aircraft.
- Know the location of first aid kit and survival equipment.
- Know the operation and location of fire extinguisher.
- Know the emergency electrical and fuel shutoffs.
- Know the operation of doors and seat belts.
- No smoking.
- Know the emergency procedures.
- Brief the pilot prior to mission on intent, known hazards, and other pertinent data.
- A flight plan is required for all flights.
- Permit only necessary flights with authorized passengers and necessary cargo.
- Report aircraft mishaps as soon as possible.

# SAFETY AROUND HELICOPTERS

Approach and depart helicopter from the side or front in a crouching position in view of the pilot.



Approach and depart downslope side to avoid main rotor.



Approach and depart in pilot's field of vision (never towards the tail rotor).



Use a chinstrap or secure hardhat when working around main rotor.



Carry tools horizontally below waist level (never upright or over shoulder).



# SAFETY AROUND HELICOPTERS



Fasten seatbelt upon entering helicopter.  
Leave buckled until pilot signals to exit.  
Fasten seatbelt behind you before exiting.



Use door latches as instructed. Exercise caution  
around moving parts or plexiglass.



Keep landing areas clear of loose items that  
could “fly” in the rotor downwash.



Do not throw items from the helicopter.



# SAFETY AROUND HELICOPTERS

Provide wind indicators for takeoff and landing, back to the wind, arms extended in front of body. See pg. 28 Helicopter Hand Signals.

Wear eye and hearing protection when working in close proximity to helicopters.

Secure items internally and externally on the helicopter. Provide the pilot with accurate weights and types of baggage or cargo to be secured.

## IN-FLIGHT EMERGENCY

- Pilot declares emergency.
- Seatbelts snug.
- Protective clothing in use.
- No smoking.
- Keep away from flight controls.
- Secure loose gear.
- Note emergency exits.
- Wait until all motion ceases before exiting

## PRECAUTIONS DURING REFUELING

- Helicopter engine must be shut off and rotorblades stopped (unless helicopter has enclosed refueling system).
- Helicopter and fuel containers must be bonded.
- No passengers are allowed on board.
- Smoking and unauthorized personnel are prohibited within 50 feet.



## AERIAL HAZARDS

- Use a hazard map of known hazards.
- Look for hazards and alert the pilot.
- Stay above 500 feet AGL whenever possible.
- Do not fly during poor visibility (half-mile minimum visibility).
- Do a high level reconnaissance before descending below 500 feet AGL.

## SUMMARY

- Check approval of pilot and aircraft data cards.
- Pilot has final say: don't question.
- If in doubt, stop flight.
- Be alert for aerial hazards.
- Designate a manager and maintain control of operation.
- Report mishaps to local aviation manager.

# HELICOPTER CAPABILITIES & LIMITATIONS

## AERODYNAMICS

Lift is accomplished by the rotation of two or more rotor blades, each having a cross section similar to that of an airplane wing. As this “wing” moves through the air spinning on an engine-driven shaft, lift is generated. The amount of lift generated by the rotor system is adjusted by changing the pitch or angle of attack at which the blades bite into the air. (Fig. 1)

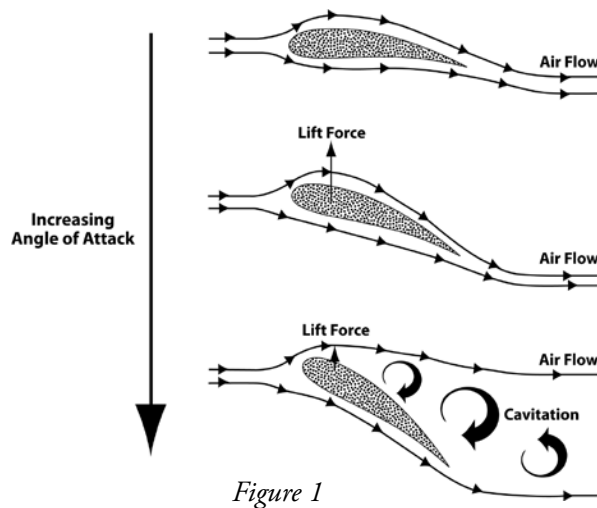

If you extend your hand out the window of a speeding car and move the angle of your hand up from a horizontal position, you can feel the lift produced as the angle is increased. A rotor blade or wing works the same way.

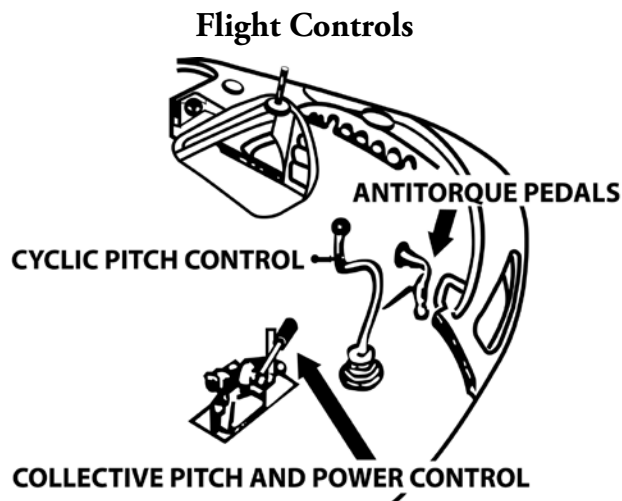

The pilot controls the helicopter with four primary flight controls. (Fig. 2)

1.) **Power** must be integrated into the system to compensate for drag and maintain constant rotor rpm. Pitch changes and power requirements to the rotor system are provided by a flight control called the “collective”. This refers to the collective or mutual effect of this control on each individual blade.

2.) The **collective pitch control** lever is generally located to the left of the pilot and moves in a simple up and down motion. For turbine engine helicopters, the collective lever is pulled up and angle of attack is increased. A fuel governor provides more fuel to the engine, which increases power. This maintains constant rotor rpm and lift is generated.

3.) The **two floor pedals** connected to the tail rotor allow the pilot to vary the amount of thrust in the opposite direction to the main rotors rotation. (Fig 3)

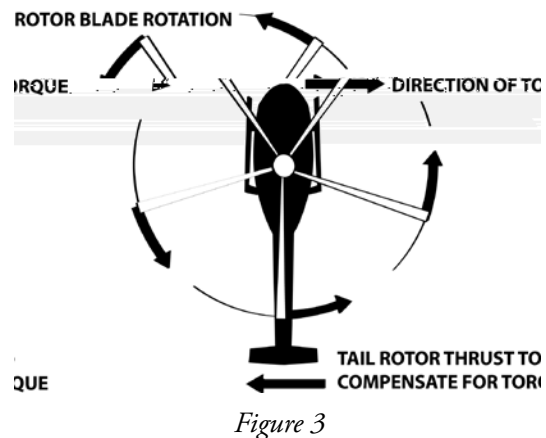

Torque is the equal and opposite reaction to rotational motion of the main rotor blades. Antitorque control is essential for helicopter flight because it prevents the helicopter from spinning out of control. On most helicopters this is accomplished by an antitorque rotor or tail rotor. Without an antitorque rotor the helicopter would spin in the opposite direction of the main rotor system.

By maintaining tail rotor thrust equal to main rotor torque, the helicopter will hold a hover. While in a hover, the antitorque pedals allow the pilot to change a heading to any direction. So what does all of this mean? In some situations (out-of-ground effect hover, maximum performance, or certain wind conditions), the maximum thrust provided by the tail rotor is unable to counteract torque generated by the main rotor. An uncontrollable turn is the result. What started as a capability is now a limitation.

# HELICOPTER CAPABILITIES & LIMITATIONS

4.) The fourth primary flight control is the **cyclic control stick** or “cyclic.” The cyclic is controlled by the pilot’s right hand. The purpose of the cyclic control is to tilt the tip path plane in the direction that horizontal movement is desired. The rotor disk tilts in the direction that pressure is applied to the cyclic.

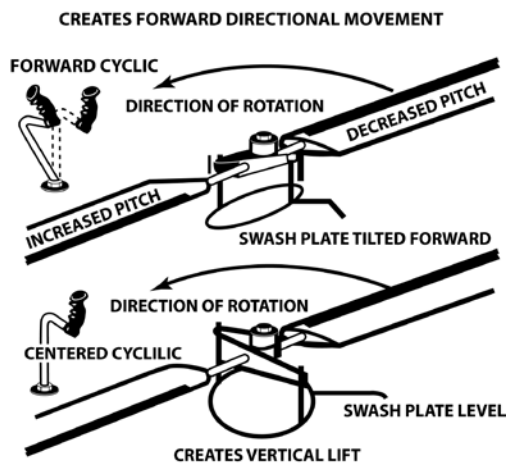

Figure 4

The cyclic pitch control produces changes in pitch to each blade individually (Fig. 4). If the pilot moves the cyclic forward, the pitch of each blade is increased as it sweeps toward the tail of the helicopter. As each blade swings forward toward the nose of the aircraft, pitch is flattened. The result is that each blade produces more lift as it swings to the rear than when it swings ahead. Lift thrust force is produced in the rear pushing the aircraft ahead. This principle occurs whenever the cyclic is moved allowing the pilot lateral and roll control of the helicopter.

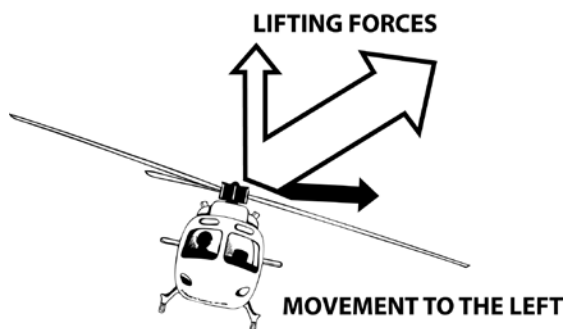

Figure 5

To hover and move to the left, pitch is changed to each blade, producing more thrust on the right side as it swings to the left (Fig.5). A sideward force is produced, pushing the helicopter in that direction.

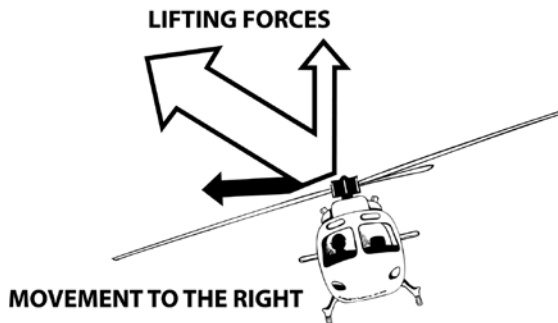

Figure 6

To move to the right, the rotor blades are unbalanced and more thrust is produced over the left side of the helicopter (Fig. 6).

## HELICOPTER PERFORMANCE

**GROUND EFFECT** is a condition of improved rotor system performance resulting from aerodynamic forces and encountered when the helicopter is hovering near the ground. The apparent result is increased lift or decreased power requirements. Simply put, the aircraft is more efficient.

**HOVER-IN-GROUND-EFFECT (HIGE)** is achieved when the helicopter is hovering about one half the rotor diameter distance from the ground. In a hover, the rotor blades move large volumes of air from above the rotors down through the system. The ground interrupts the airflow under the helicopter, reducing the downward velocity of the air and producing an outward airflow pattern.

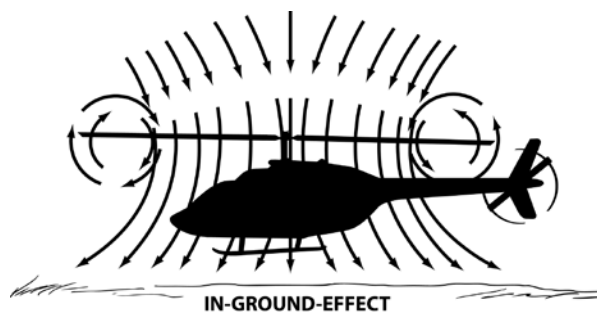

Figure 7

Simplified, a cushion of air has been created between the ground and the helicopter, lift is increased, and power requirements are reduced (Fig 7). Maximum ground effect is accomplished over smooth, level surfaces. Hovering over tall grass, rough terrain, or water dissipates this cushion and may reduce or eliminate ground effect.

# HELICOPTER CAPABILITIES & LIMITATIONS

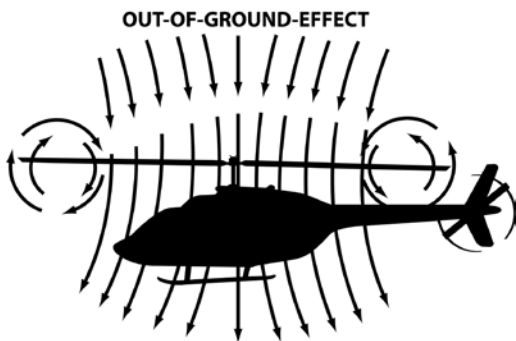

Figure 8

**HOVER-OUT-OF-GROUND-EFFECT (HOGE)** occurs when the helicopter exceeds about one half the rotor diameter distance from the ground and the cushion of air disintegrates (Fig 8). To maintain a hover, the helicopter is now power dependent. This situation will occur when the terrain does not provide sufficient ground effect base or when performing external load work. Maximum performance is required and payload may have to be reduced.

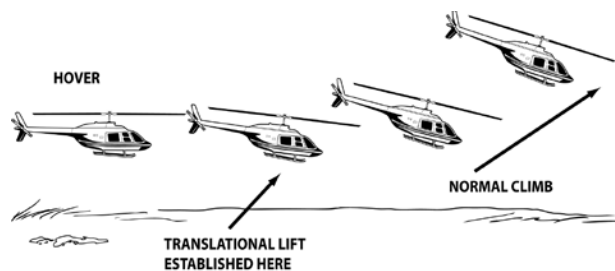

Figure 9

We should understand the capabilities and limitations presented by ground effect when choosing a landing site. When planning a helicopter project, the safety and efficiency of the operation will be enhanced by selecting landing areas that allow the pilot to approach into the wind and hover-in-ground-effect (HIGE).

Normal takeoff and landings are initiated by bringing the helicopter to an in ground-effect hover and translating the aircraft into forward flight. (Figs. 9 & 12) externally on the helicopter. Provide the pilot with accurate weights and types of baggage or cargo to be secured.

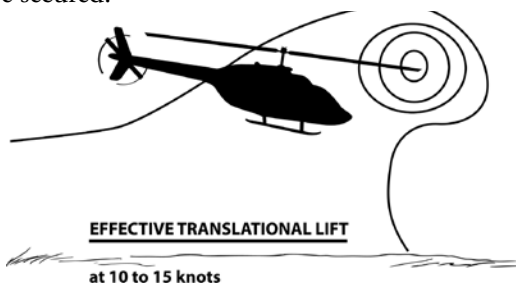

Figure 10

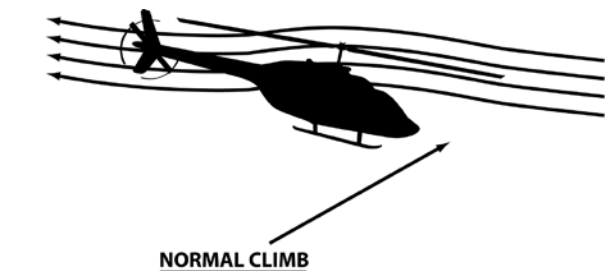

Figure 11

Additional lift is gained as the helicopter moves from the turbulent air created from hovering, to undisturbed, "clean" air which moves through the rotor system as the helicopter increases airspeed (Fig. 11).

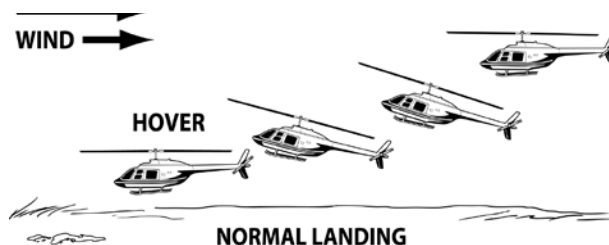

Figure 12

Rotor system efficiency is increased when entering horizontal flight, reducing power requirements and increasing a safety margin. This is defined as translational lift and occurs when the helicopter approaches 15 to 18 m.p.h. indicated airspeed. (Fig. 10) Translational lift will also be produced when the helicopter is hovering with a 15 m.p.h. steady headwind. As you can see, a steady headwind can benefit the pilot.

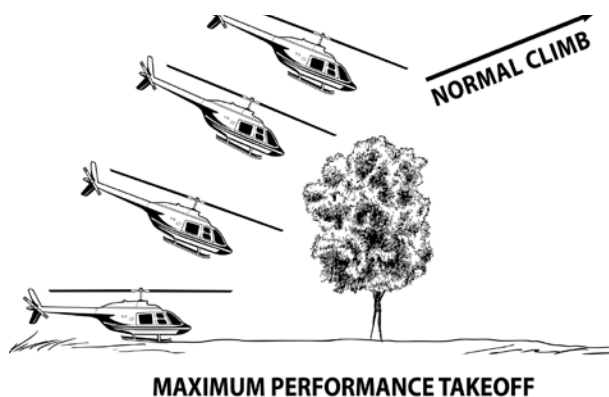

Figure 13

On many occasions, a maximum performance takeoff or landing must be accomplished. This occurs when the helicopter hovers out-of-ground-effect (HOGE), before or after translational lift (Figs. 13 & 14).

# HELICOPTER CAPABILITIES & LIMITATIONS

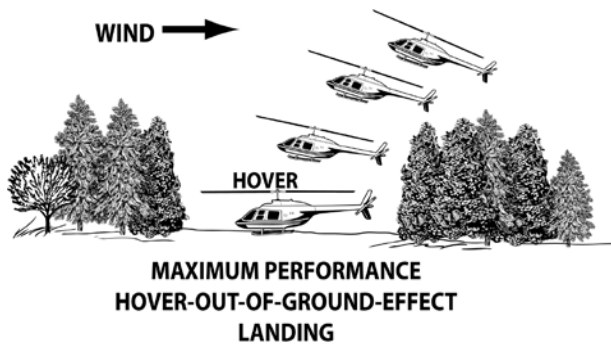

Figure 14

In this situation, the helicopter is totally power dependent and the margin of safety is significantly reduced. When possible, avoid confined areas, or large obstructions that require the pilot to use maximum power for extended periods.

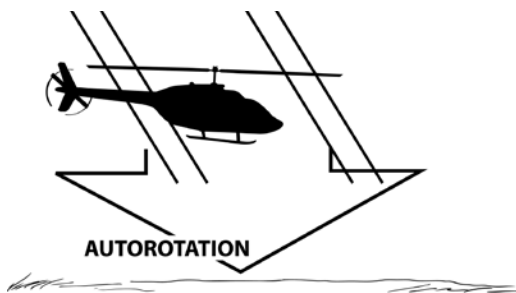

Figure 15

**AUTOROTATION** is a non-powered flight condition in which the rotor system maintains flight rpm by reversed airflow. (Fig. 15) It provides the pilot a means of safely landing the helicopter after an engine failure or other mechanical emergency.

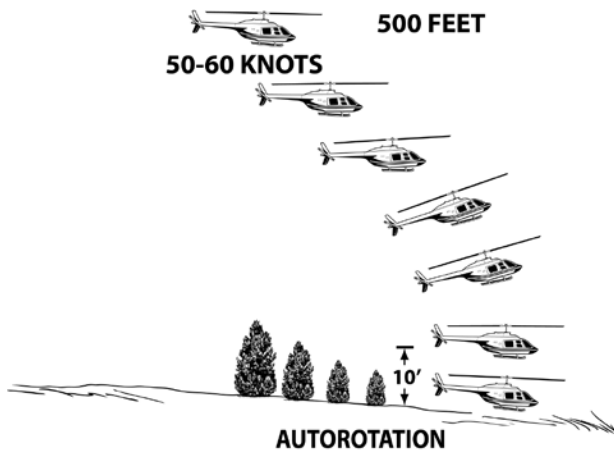

Figure 16

Helicopters have a freewheeling unit in the transmission which automatically disengages the engine from the rotor system in the event of a failure. This allows the main rotor to rotate freely.

When the helicopter is powered by the engine, airflow is downward through the rotors. During an autorotation, airflow is upward, “wind milling” the rotor blades as the helicopter descends (Fig. 15). The pilot maintains constant rotor r.p.m. by changing pitch to the blades as the aircraft continues descent. As the helicopter approaches a landing site, the pilot flares the aircraft by moving the cyclic back and gently lifting the nose. This slows the forward airspeed and rate of descent.

Before touchdown, the helicopter is leveled and the pilot utilizes the stored up blade inertia to cushion the helicopter onto the ground. The autorotation is complete (Fig. 16).

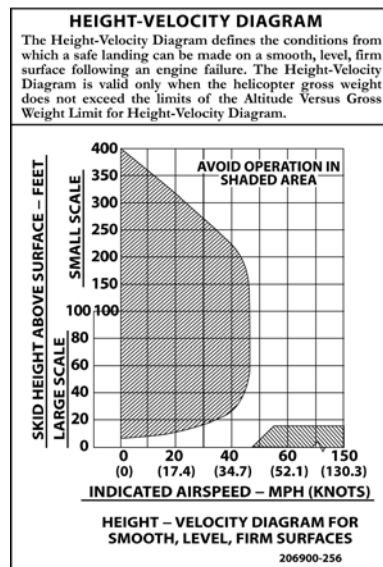

Figure 17

In the flight manual for each helicopter type is a chart which provides necessary information to complete a safe autorotation. This is a height velocity curve, indicating the comparative combination of airspeed and altitude required to accomplish a safe autorotation (for most light helicopters, 350 to 450 feet above ground level at zero airspeed). (Fig. 17) By flying low level, or performing extended hovers, we are dramatically reducing our safety margin and limiting the pilot’s options.

**DENSITY ALTITUDE** refers to a theoretical air density which exists under standard conditions at a given altitude. Density altitude is altitude corrected for non-standard pressure, temperature, and humidity; moreover, it is the altitude which the aircraft “thinks” it’s at. It can have a profound effect on aircraft performance. Air, like other gases and liquids, is fluid. It flows and changes shape under pressure. Air is said to be “thin” at higher elevations. There

# HELICOPTER CAPABILITIES & LIMITATIONS

are fewer air molecules per cubic foot at 10,000 feet than at sea level. At lower elevations, the rotor blade is cutting through more dense air, which provides additional lift and increased performance. There are three factors that affect density altitude in varying degrees: atmospheric pressure, temperature, and, to some degree, humidity.

The lower the pressure at a given elevation, the less dense the air. Helicopter performance is decreased. To determine the pressure altitude at a given location, use the altimeter in the helicopter. Have the pilot adjust the altimeter to 29.92 Hg, the standard sea level atmospheric pressure (Fig. 18 ). The altimeter converts barometric pressure to pressure altitude. The most dramatic influence on density altitude is temperature. The same volume of air contained in one cubic foot, at a low temperature, will expand two or three times as temperature rises. (Fig. 19)

**Standard conditions at sea level are:**  
Atmospheric pressure-29.92 in. of Hg (inches of mercury) at 59 degrees F. (15 Degrees C.)  
Atmospheric pressure decreases approximately 1 inch per 1000-foot increase in altitude. The average temperature decrease per 1000-foot increase in altitude is 3.5 degrees F. (2 degrees C.)

Figure 18

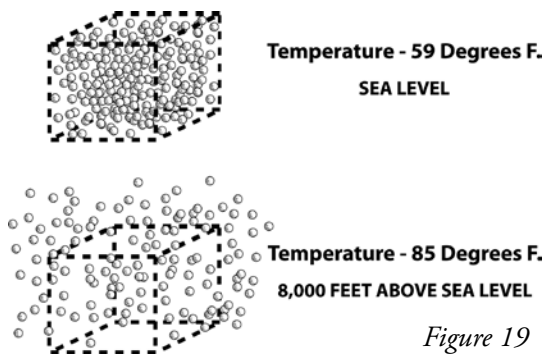

Figure 19

There are fewer air molecules, because of expansion, in a given space so the air has become less dense. The rotor blades have less air to grab and performance is decreased. The same is true with an airplane wing. To compensate for loss of lift, power requirements must be increased, thus providing a limitation to the aircraft. It is important to note that high density altitudes may be present at low elevations on hot days. High moisture content will also increase density altitude, but to a minor degree.

When planning a helicopter project, we can see the importance of starting early in the morning when temperatures are cool, to maximize the performance of the aircraft.

## WEIGHT AND BALANCE

All helicopters are designed for certain load limits and balance conditions. The pilot is responsible for seeing that weight and balance limitations are not exceeded before takeoff. [We can help the pilot by providing accurate weights of passengers and cargo.]

Three kinds of weight must be considered by the pilot: **empty weight, useful load, and gross weight.**

- **Empty weight** is the total weight of the helicopter including all fixed equipment, oil, hydraulic fluid, and coolant. This does not include fuel or the pilot.
- **Useful load (payload)** is the weight of the pilot, passengers, cargo, and fuel.
- **Gross weight** is the empty weight plus the useful load.

**Maximum gross weight** is the maximum weight that the helicopter can weigh and safely fly at sea level on a standard day. This is certificated by the Federal Aviation Administration for each helicopter type. Although a helicopter is certified for a specified maximum gross weight, it will not safely perform with this load in all conditions. It may be required to "download" by removing some cargo, passengers, or less fuel in the helicopter. Such conditions would include high density altitude, takeoffs and landings in rough terrain, or confined areas. Of the three major factors influencing the performance of a helicopter (density altitude, wind, and gross weight), the pilot can control only the gross weight. The pilot can determine the gross weight by referring to the computed gross weight charts in the performance section of the flight manual.

The charts are computed for hover-in-ground-effect (HIGE) ( Fig. 20 ) and hover-out-of-ground-effect (HOGE) (Fig. 21 ). If the outside air temperature (OAT) and pressure altitude are known, or at least estimated closely, the pilot plots them on the chart. The chart gives a computed gross weight calculated for HIGE or HOGE. This is the computed gross weight that can be used for that specific temperature and altitude, for takeoffs and landings. Computing the gross weight can be an effective planning tool to transport cargo to various locations under particular conditions and to enhance the safety and efficiency of an operation. [Bureaus in the Department of the Interior (DOI) with wildland fire responsibility utilize Departmental helicopter load calculations (AMD-67) prior to any flight. The form provides an allowable payload by utilizing computed grossweights and affords a safety margin (Fig. 22).]

# HELICOPTER CAPABILITIES & LIMITATIONS

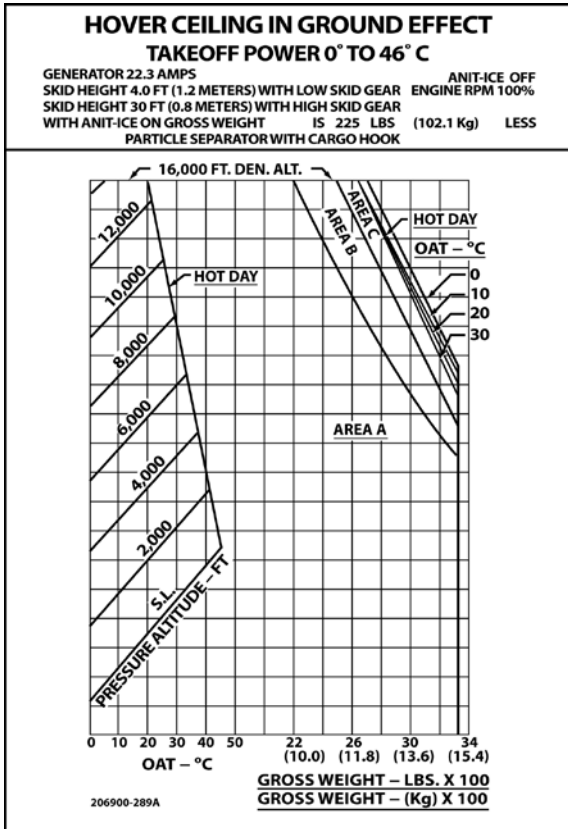

Figure 20

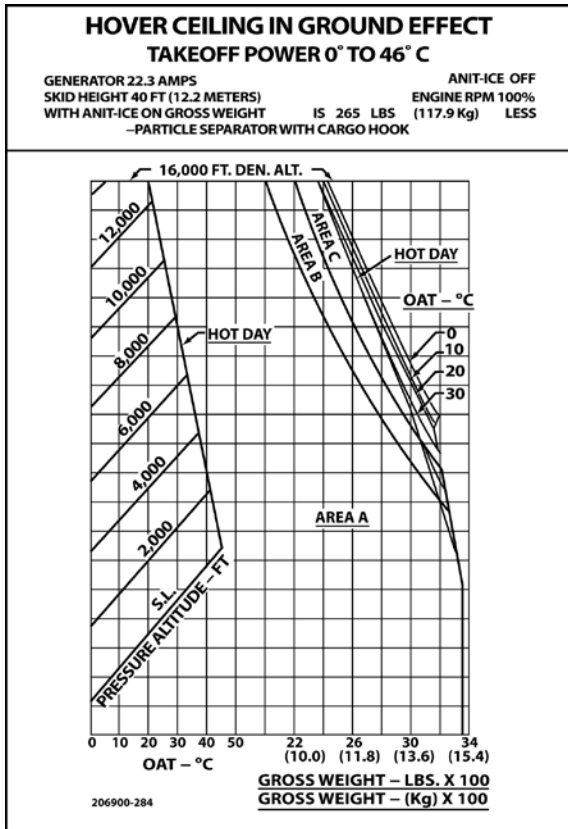

Figure 21

INTERAGENCY HELICOPTER		MODEL
LOAD CALCULATION		N#
AMD-67/FS 5700 (10/06)		
PILOT(S)		DATE
MISSION		TIME
1 DEPARTURE	PA	OAT
2 DESTINATION	PA	OAT
3 HELICOPTER EQUIPPED WEIGHT		
4 FLIGHT CREW WEIGHT		
5 FUEL WT ( _____ gallons X _____ lbs per gal)		
6 OPERATING WEIGHT (3 + 4 + 5)		
	Non-Jettisonable	
	HIGE	HOGE
	Jettisonable	
	HOGE-J	
7a PERFORMANCE REF		
(List page/chart from FM)		
7b COMP GROSS WT		
(FM performance Section)		
8 WT REDUCTION		
(Req for all Non-Jettisonable)		
9 ADJUSTED WEIGHT		
(7b minus 8)		
10 GROSS WT LIMIT		
(FM Limitations Section)		
11 SELECTED WEIGHT		
(Lowest of 9 or 10)		
12 OPERATING WEIGHT		
(From Line 6)		
13 ALLOWABLE PAYLOAD		
(11 minus 12)		
14 PASSENGERS/CARGO MANIFEST		
15 ACTUAL PAYLOAD		
(Total of all weights listed in Item 14)		
Line 15 must not exceed Line 13 for the intended mission.		
PILOT SIGNATURE		
MGR SIGNATURE		
	HazMat Yes ___ No ___	

Figure 22

**Note: Figures 20-22 are samples only and are not to be used for the planning of missions.**

# HELICOPTER CAPABILITIES & LIMITATIONS

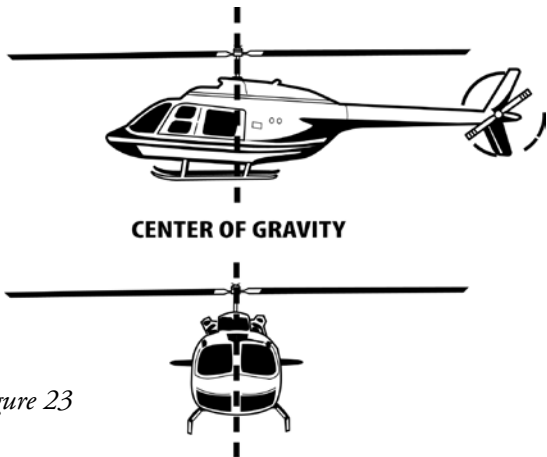

Figure 23

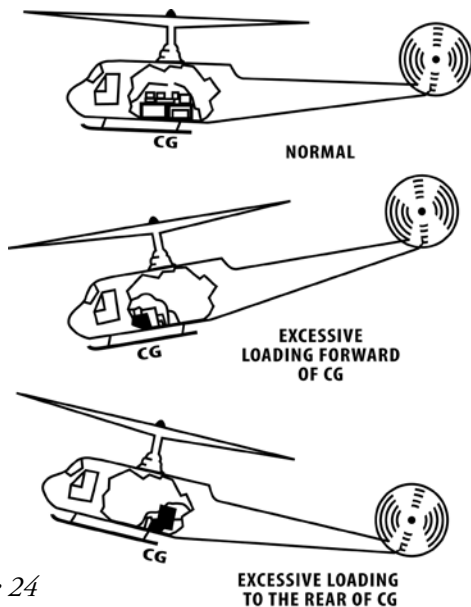

Figure 24



Figure 25

In conjunction with determining the gross weight of the helicopter, the pilot must consider how the load is balanced within the center of gravity limitations of the aircraft.

**Center of Gravity (CG)** is the point where the helicopter is in balance and most of the weight is concentrated. Draw an imaginary line through the center of the rotor mast, from the top of the mast to the bottom of the helicopter. This would be the center of gravity (Fig. 23). Ideally, the helicopter should be in perfect balance. The fuselage will remain horizontal in hovering flight, with no cyclic pitch control required. Center of gravity is located directly under the rotor; the helicopter hangs horizontal.

If the center of gravity is too far behind the mast, the helicopter hangs with a nose-up attitude. If the center of gravity is too far forward, the nose tilts forward, the nose tilts down (Fig. 24). Out-of-balance loading make control more difficult and decreases maneuverability. Cyclic control is restricted opposite to CG location. Cargo should be loaded as close to the center of gravity as possible.

When loading cargo laterally, or side to side, try to keep the weight evenly distributed (Fig. 25). Let the pilot know what passengers or cargo are being loaded and where. Cargo must be secured inside the helicopter and in the external cargo baskets.

The majority of human error accidents are related to the fact that helicopters are flown in unusual and difficult situations where the margin of error is small and the penalty can be great. By understanding flight characteristics and knowing when a capability is changing to a limitation, we will become better helicopter managers and active participants in aviation risk management.



# PERSONAL PROTECTIVE EQUIPMENT

**Personal Protective Equipment (PPE)** consists of clothing and equipment that provide protection to an individual in a hazardous environment. Departmental policy requires that crewmembers and passengers wear the following appropriate complement of PPE for preplanned "special use" activities:

**Aviator's helmet** must provide protection for the head, ears, and temple and must provide communications for the pilot and crewmembers.

**Fire resistant clothing** material must be polyamide, aramide (commonly referred to as "Nomex"), polybenzimidazole, Kevlar, or blends thereof. The length should be sufficient to eliminate exposure between the boots and Nomex clothing.

**Leather boots** which extend above the ankle.

**Leather gloves, or Nomex and leather,** are required.

**An FAA or U.S. Coast Guard approved personal flotation device (PFD)** is required to be worn on all single-engine flights over water beyond power-off gliding distance to shore. Personal flotation devices will be readily available to occupants of multiengine land aircraft operating beyond gliding distance from shore.

When conducting fire-related water dipping or snorkel operations, PFDs shall be worn by occupants aboard a helicopter hovering over water sources such as ponds, streams, lakes, and coastal waters.

**Anti-exposure suits** must be worn in all single-engine aircraft and readily available to occupants of multi engine aircraft when conducting extended overwater flights when the water temperature is less than 50 degrees Fahrenheit.

## Exceptions to the PPE requirements for "special use" activities are:

- Fire resistant clothing for aerial agricultural applications.
- Fire resistant clothing and leather boots for over-water flights during vessel or offshore platform operations.
- Aviator's helmet requirements for fire crews being transported between designated landing sites or air attack supervisor operations above 500 feet AGL. (Air attack supervisor operations involved in airtanker coordination operations require all personnel on board to wear PPE.)

**"Special use"** activities are described as DOI programs which require special considerations due to their functional use. Situations in which special pilot qualifications, techniques, or special aircraft equipment are incorporated, personal protective equipment is required.

## The following are examples of "special use" activities:

- External loads, Class B or C (slingloads, longline, water buckets, etc.)
- Night vision goggles
- Helicopter rappelling/short-haul/cargo letdown
- Animal herding
- Offshore platform landings
- Flights conducted below 500 feet above ground level (AGL)
- Helicopter operations around a fire perimeter
- Helitack or initial attack
- Water/retardant application
- Aerial ignition
- Animal tagging and eradication
- Paracargo/smokejumping
- Any takeoff or landing requiring special pilot technique due to terrain, obstacles, or surface condition.
- Single-skid, toe-ins and hover entry/exit procedure (STEP)
- Wheel operations on unprepared landing area (airplane).

# PERSONAL PROTECTIVE EQUIPMENT

## AVIATOR'S PROTECTIVE HELMET (FLIGHT HELMET)

Most Government bureaus and agencies use flight helmets manufactured by the Gentex Corporation. The first model was the SPH4, and most recently is the SPH5 (Sound Protective Helmet).

A unique feature of the helmet is that it integrates a floating suspension system that minimizes head injury from acceleration or deceleration forces.

The helmet is made in two sizes. Regular will fit hat sizes to 7 1/4 and extra-large, 7 1/4 and greater. If the helmet is exchanged with various personnel, it is suggested to purchase extra-large helmets.

**To provide maximum protection, the helmet must be individually fitted and properly worn.** Adjusting the helmet for proper fit is important. A loose fitting helmet is uncomfortable and can be dangerous. The helmet will stay properly positioned and provide maximum head protection during deceleration forces up to 6.0 G's.

- Before putting the helmet on, adjust the buttons or knobs on the earcups to fit in the depression behind the ear. Earcups should be centered over the ear and apply sufficient pressure to minimize external noise.
- The front edge of the helmet should be no more than 3/4-inch above the eyebrow. To raise or lower it on the head, adjust the three web straps evenly, that are attached to the crown pad. This is the floating suspension system and should be adjusted to keep the crown pad from touching the inside liner of the helmet. Check the straps by pushing down with a fist on the crown pad.
- The sweatband should be adjusted to fit snug and minimize head movement in the helmet.
- When wearing the helmet, attach the chinstrap to the two lower snaps and pull snug.
- Tighten the nape strap in the back of the helmet so the Velcro/Nomex adjustments lay flat against the head. The nape strap minimizes the possibility of the helmet coming off in the event of the head being thrown forward.
- The visor should be in the down and locked position during takeoffs and landings.
- The microphone is noise cancelling. It should be almost touching the lips to maximize effectiveness.
- When not in use, store the helmet in a helmet bag.

Gentex no longer manufactures the SPH 4. Instead, they redesigned the sound protective helmet, making it lighter in weight and replacing the floating suspension system with a preformed thermoplastic liner (TPL). The TPL unit provides for easier fit, and allows for custom fitting if needed. Refer to manufacturer's instructions for proper fitting.

The helmet and liner still come in only two sizes, regular and extra-large, same as the SPH4.

Upgrades are available from the Gentex cooperation to convert the SPH4 head suspension system to a thermoplastic liner.

Many lives have been saved and serious injury prevented by wearing an aviator's protective helmet. It has been proven countless times that the aviator's protective helmet saves lives! In a crash situation, it is imperative to have some type of head protection. For more information reference *DOI Aviation Life Support Equipment Handbook* and *Flight Helmut Users Guide*.

## FIRE RESISTANT CLOTHING

Helicopter safety and technology has improved immensely since the days of piston-driven engines. Although the turbine-engine helicopter provides increased reliability, there is still a potential for a postcrash fire. You can minimize this hazard by wearing fire resistant clothing. Nomex (polymid or aramid) material is the current standard utilized for fire resistant clothing.

## WHAT YOU SHOULD KNOW ABOUT NOMEX

Nomex is an uncomplicated material, but it has been the subject of many questions, misconceptions, abuses, and just plain untruths.

## THE MATERIAL

Nomex is a unique manmade material that is permanently fire retardant. Nomex is a registered trademark of a synthetic material developed by the DuPont Corporation. It is a type of nylon that will not melt and stick to the skin as other types of synthetic fibers do. **Because other synthetics such as nylon and dacron melt at about 300 degrees F, they should not be worn next to the skin.**

**Crewmembers and passengers should remember** that heat transfer through Nomex could be high enough to melt synthetic undergarments. Nomex is resistant to temperatures up to about 700 degrees F and then begins to char and form a dry, brittle residue that can be brushed away when the heat source is removed. Nomex will not support combustion as other natural and manmade materials will. For example, if a flame is placed directly on cotton, nylon, dacron, etc., the materials will burn and continue to burn when the heat source is removed.

# PERSONAL PROTECTIVE EQUIPMENT

If your Nomex does become contaminated with flammable products, simply launder and the material will be restored to its original fire retardant state. At this time, there is no wear-out criteria for Nomex. According to the U. S. Army Natick Research and Development Command, even thin Nomex provides protection.

## CLOTHING FIT

Nomex clothing was designed to be worn rather loosely to provide an airspace between the fabric and the skin. This airspace acts as insulation from heat sources. Do not alter Nomex clothing; snugly fitted Nomex negates the effectiveness of the airspace.

## STATIC ELECTRICITY

**One of the most important safety procedures** in preventing an accident caused by static electricity during refueling is proper grounding of the aircraft.

**Another equally important safety procedure** is plugging in the bonding wire from the fuel nozzle to the aircraft before the fuel cap is removed. Replace the fuel cap before unplugging the bonding wire.

**If your Nomex becomes saturated with fuel, the saturated area should be thoroughly soaked in water before removal of clothing to prevent static electricity from igniting the fuels.** One crewmember received first- and second-degree burns when his fuel-soaked clothing ignited by static electricity as he tried to remove them without first washing the saturated area with water.

## CLEANING

Garments of Nomex can be cleaned by home or commercial laundry procedures without the loss of their outstanding protective features.

Nomex can be laundered as many times as necessary and still be fire resistant. Since it is an easily cleaned synthetic fiber, you probably won't need a full wash cycle. Simply set the washing machine on a short cycle; e.g., "delicate" or "wash and wear." Wash garments with a heavy-duty detergent such as Tide, Cheer, All, or Whisk.

Pretreat greasy stains and collar/cuff lines with a product such as Spray 'n Wash or Shout.

Launder garments of Nomex only with other Nomex garments to help avoid surface entrapment of flammable lint and to minimize static in the tumble dryer. Close the zippers to prevent damage and fasten the velcro to avoid picking up lint. Remember, Nomex is high temperature resistant and has even been boiled without damage. However, to conserve energy, it is suggested to use a warm wash and cold rinse.

If Nomex is tumble dried separately from other material, an antistatic strip probably will not be required to remove static electricity. Tumble dry garments at a medium or high temperature setting. Use the cool down cycle if available; remove and hang garments as soon as tumbler stops. The rubbing of dissimilar materials causes static electricity buildup. If you live in a cold, dry climate and static electricity is a nuisance, you can use a good brand of fabric softener in the wash or a strip in the dryer.

For maximum fire protection, grease and oils should be thoroughly removed from garments of Nomex after each wearing. If home washing procedures do not accomplish this, commercial laundering or dry cleaning is recommended.

# PERSONAL PROTECTIVE EQUIPMENT

## ADDITIONAL FACTS

The flightsuit should be fastened over the boot. Sleeves are to be worn down, zippers zipped to the top and collar turned up. Of course, Nomex or leather gloves are to be worn. Wear the gloves under the sleeve cuff to prevent accidental snagging of any helicopter controls or switches.

The unprotected throat area comprises less than 1 percent of the total skin area. In contrast, the skin of the face makes up about 5 percent of the total skin area and is not protected by Nomex. The unprotected face has not received the consideration and publicity the neck has and yet covers five times the skin area of the unprotected neck area. The helmet visor offers the upper portion of the face only limited protection in a flash fire or a full-fledged, raging inferno. Some enterprising individuals have fabricated scarves from Nomex for neck protection at very little cost.

Nomex is Nomex regardless of the weave, color, or article of clothing. Take care of it and it will take care of you when you need it most. This garment could save your life. It is made of Nomex Aramid, a fiber that is high temperature resistant and permanently flame resistant.

The next generation of material is polybenzimidazole (PBI) or kevlar, which have enhanced fire resistance and improved comfort. To obtain maximum protection it is important to wear cotton, wool, cotton-wool blend, or Nomex undergarments. Maximum protection, is based upon the thickness and the amount of skin contact to the material.

Synthetic or petroleum-based materials (nylon, polyester, or polypropylene) impose a hazard of high flammability and melting to the skin and should not worn under fire resistant clothing. During the flight safety briefing, passengers and crewmembers should be made aware of the inherent danger associated with wearing synthetic materials.

The PPE requirements and recommendations provided are for all aviation users. Past experience and unfortunate circumstances have shown that an ounce of prevention far outweighs the inconvenience and occasional discomfort of using personal protective equipment.

## AIRCRAFT RESTRAINT SYSTEMS

Agency and contractor personnel are required to have and use a restraint system, or safety belts, during all phases of aircraft flight operations. There are many different types of safety belts dependent upon the type of aircraft and seat location. In the interest of safety it is best for passengers of aircraft to become familiar with the operations of their safety belts. Being familiar with safety belts will help passengers enplane and deplane more efficiently with less confusion, and in the event of an emergency, will improve reaction times. Below are graphics showing different types of restraint systems and where passengers should expect to find them.



**TWO-POINT SYSTEM**

*Figure 1*

The two-point system (Fig. 1) consists of a lap belt which crosses the passenger at the waist. This system has two points of contact to restrain the passenger, thus the name “two-point system.” Passengers could expect to find these in the rear seats of fixed-wing aircraft as a minimum. Some fixed-wing aircraft have done away with these and moved to a three-point system.

The three-point system (Fig. 2) is similar to the safety belts in the front seats of automobiles. Like the two-point system the three-point system has a lap belt plus a shoulder harness running diagonally across the body of the passenger for three points of contact. Passengers can find three-point restraint systems in the rear seats



**THREE-POINT SYSTEM**

*Figure 2*

of rotor-wing aircraft and in the front seats of fixed-wing aircraft at a minimum. Front seats are defined as seats located at a flight crewmember’s station, such as the pilot seat, or any seat located alongside such a seat.

# PERSONAL PROTECTIVE EQUIPMENT

Four-point systems (Fig. 3) have a double-strap shoulder harness (one strap comes over each shoulder) and fastens with the lap belt. Four-point systems are a minimum requirement for front seats of helicopters and the front and tandem seats of airplanes which take off and land on water.



**FOUR-POINT SYSTEM**

*Figure 3*



**FIVE-POINT SYSTEM**

*Figure 4*

Five-point systems (Fig. 4) are similar to four-point systems; however, incorporated into the design is a crotch strap. This restraint system has a metal-to-metal, single-point, quick release mechanism. Five-point harnesses may also be found on front and tandem seats in airplanes which take off and land on water.

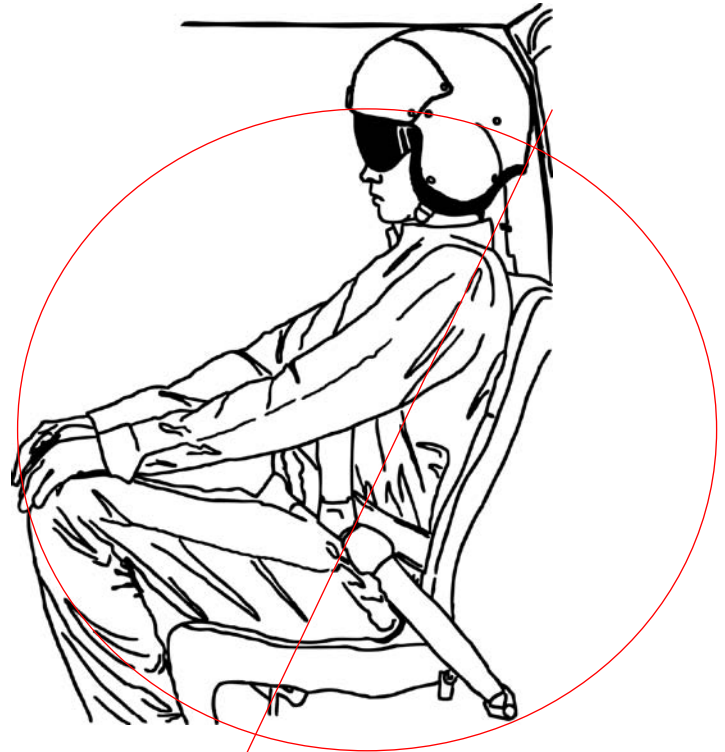

**HELICOPTER CRASH POSITION**

*Figure 5*

~~Passengers shall use the emergency seating position identified in Figure 5. Passengers with shoulder harnesses shall sit in full upright position with head and back against seat and use arms to brace in position as shown (Fig. 5) regardless of seating configurations.~~

**See Interagency Aviation Safety Alert No. IA SA 13-01 Helicopter Brace for Impact Positions located at the back of this publication for updated information.**

*There are no official guidelines on emergency positions in airplanes.*

# AIRPLANE SAFETY

Operations will comply with the applicable general safety rules for operations and practices prescribed in agency manuals, Federal, State, and OSHA standards.

## GENERAL SAFETY PRECAUTIONS

Upon arrival and prior to flight, check pilot and aircraft data cards.

- The pilot is responsible for the safety of the aircraft and passengers at all times.
- Request a safety briefing from the pilot concerning safety features of the aircraft.
  - Approach and depart airplane when the engine and propeller(s) have come to a complete stop.
  - Operation of doors and emergency exits.
  - Use and operation of seatbelts.
  - Seats in an upright position during takeoff or landing.
  - No smoking.
  - Location of firstaid and survival equipment.
  - Operation and location of fire extinguisher.
  - Location of emergency electrical and fuel shutoff.
  - Ditching procedures and location of flotation equipment for extended overwater flights.
  - Normal and emergency use of oxygen.
  - Emergency procedures.
- Brief the pilot prior to mission on intent, known hazards and other pertinent data.
- A flight plan is required for all flights.
- Front seat occupants must wear shoulder restraints.
- Passengers in the front seat and in tandem seat aircraft must avoid interfering with flight controls and switches.
- Permit only necessary flights with authorized passengers and cargo.
- Report aircraft mishaps as soon as possible.

## SAFETY AROUND AIRPLANES

- Approach and depart in view of the pilot only when engine and propeller(s) have come to a complete stop.

With multiple engine airplanes, it is required that all engines on the passenger door side be turned off during boarding and exiting. If cargo must be unloaded from the opposite side, a guard will be posted to protect personnel from moving propellers.

- Cabin door in front of wing, walk to the front, avoiding the propeller area, never under the wing.
- Cabin door below, or behind wing, walk behind wing, then toward wing tip and door. Avoid walking under wing.
- When entering and exiting, use designated steps, or wing walkways. Do not step where "no step" is indicated.
- Use door latches as instructed.
- Secure loose items in the aircraft.
- Provide the pilot with accurate weights and types of baggage or cargo.
- During refueling, passengers must be out of aircraft and at least 50 feet away. No smoking within 50 feet.

## IN-FLIGHT EMERGENCY

- Pilot declares emergency.
- Seatbelt snug.
- Protective clothing in use (if applicable).
- Keep away from flight controls.
- Secure loose gear.
- Note emergency exits.
- Wait until all motion stops (except in the event of a postcrash fire).
- Exit aircraft.

## AERIAL HAZARDS

- Use a hazard map for known hazards.
- Look for hazards and alert the pilot.
- Stay above 500 feet whenever possible.
- Do not fly during poor visibility (one mile minimum).
- Do a high-level reconnaissance before descending below 500 feet AGL.

# AIRPLANE CAPABILITIES & LIMITATIONS

## INTRODUCTION

Airplanes provide us the capability of accomplishing a variety of tasks. We use them in our job for resource management, various utility purposes and in traveling from point to point. By having a fundamental understanding of aircraft performance and limitations we can develop a better relationship for information sharing with the pilot. This allows us to improve our comfort level and increase our knowledge of how an airplane flies.

## BASIC AERODYNAMICS

The only way air can exert a force on a solid body, such as an airplane wing, is through pressure. A wing or “airfoil” is generally designed to increase the velocity of the air flowing over the top, reducing the pressure. The top of the wing is curved, while the bottom is flat. Because of the curve, air traveling over the top must travel farther and at greater speed, than on the bottom. This creates a low pressure area above the wing, and a high pressure area below. The higher pressure pushes the wing towards the lower pressure area, resulting in lift. At the same time, the air flowing along the underside of the wing is deflected downward. The downward deflection also reacts by lifting the wing upward (Fig. 1).

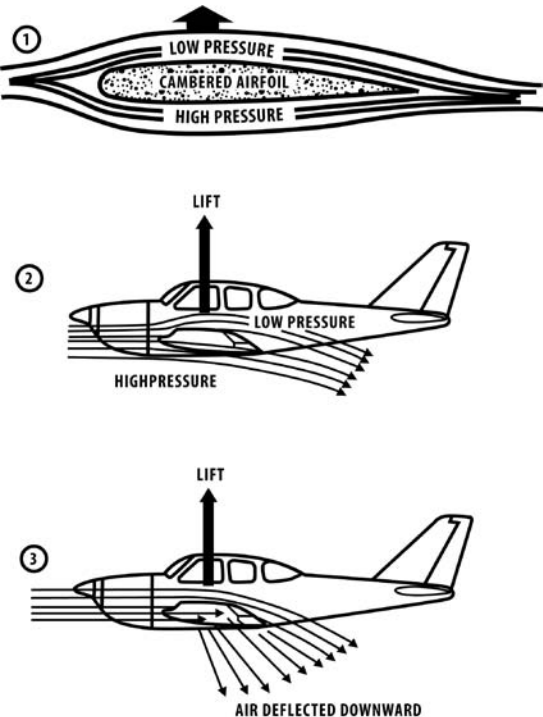

Figure 1

An airplane must move through the air with enough speed to create sufficient lift to support the aircraft. To accomplish this, the airplane must be either pulled or pushed through the air by an engine-driven propeller or jet engine. To develop a better understanding of the capabilities of an airplane, other forces must be considered.

Like all objects, aircraft are affected by gravitational force. Power is provided by the aircraft’s engine(s) which is converted to thrust to propel the aircraft through the air and create lift which counteracts the weight of the aircraft. Another force that constantly acts on the airplane is called drag. This resistant force is produced as the airplane moves through the air. To provide the aircraft with forward motion, thrust must overcome drag. In steady flight (no change in speed or direction) the opposing forces are equal, lift equals weight, and thrust equals drag. (Fig. 2)

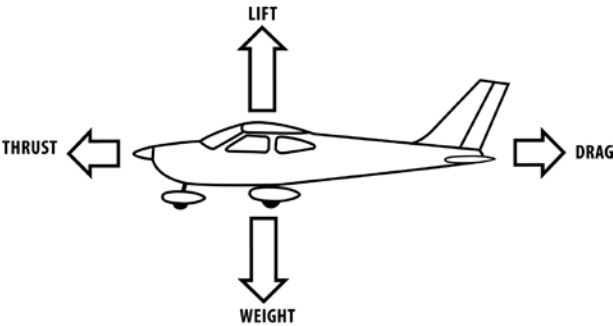

Figure 2

## FLIGHT CONTROL

To maneuver an airplane, the pilot must control its movement or rotation around its longitudinal, lateral and vertical axes. Rotation about the airplane’s longitudinal axis (nose to tail) is roll, (or “bank”). Rotation about its lateral axis (wing tip to wing tip) is pitch, and rotation about its vertical axis (up and down through the center of gravity) is yaw. This is accomplished by the use of the exterior flight controls, ailerons, elevators, and rudder. Each can be deflected from their neutral position into the flow of air as the airplane moves forward through the air.

# AIRPLANE CAPABILITIES & LIMITATIONS

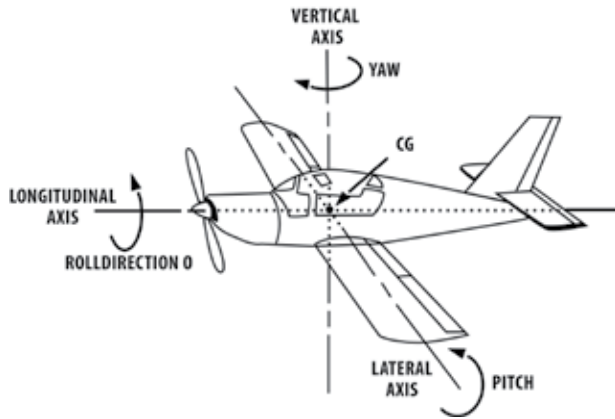

Figure 3

**The ailerons control the airplane about its longitudinal axis.** There are two ailerons, one at the trailing edge of each wing, near the wingtips. They are movable surfaces hinged to the wing's rear spar and are linked together by cables or rods. When one aileron is deflected down, the opposite aileron moves up. When the pilot applies pressure to the left on the control stick, or turns the yoke to the left, the right aileron deflects downward, and the left aileron deflects upward. This produces decreased lift on the left wing and increased lift on the right causing the aircraft to roll and bank to the left. Contrary to popular belief, the differential lift on the wings is the force that turns the airplane in flight, not the rudder. The rudder is primarily a "trimming" device in flight and is used to counteract the unequal drag of the ailerons.

**The elevators control the movement of the aircraft about its lateral axis.** They form the rear part of the horizontal stabilizer, are free to be moved up and down by the pilot, and are connected to the control stick or yoke in the cockpit. Applying forward pressure on the control causes the elevator surfaces to move downward, pushing the tail upward and the nose downward. In effect, the elevators are the angle-of-attack control. When back pressure is applied on the control, the elevators move upward, the tail lowers and the nose rises thus increasing the wing's angle of attack, and lift is generated.

**The rudder controls movement ("yaw") of the aircraft about its vertical axis.** Like the other primary control surfaces, the rudder is a movable surface hinged to a fixed surface, in this case to the vertical stabilizer, or fin. Movement of the rudder is controlled by two rudder pedals (left and right). Its action is very much like that of the elevators, except that it moves in a different plane (vertical).

The rudder deflects from side to side instead of up and down. When the rudder is deflected to one side, it protrudes into the airflow, causing a horizontal force to be exerted in the opposite direction. This pushes the tail of the airplane in that direction and yaws the nose in the desired direction. The primary purpose of the rudder in flight is to counteract the adverse yaw of the ailerons and to help provide directional control. In flight the rudder does not turn the aircraft. Instead the force of the horizontal component of wing lift turns the airplane when the wings are banked. Rudder alone cannot produce a coordinated turn. (If rudder alone is used to try to turn the airplane, the airplane "skids".) The combined blending of aileron, rudder, and elevator pressure accomplishes this maneuver. (Figs. 3 & 4)

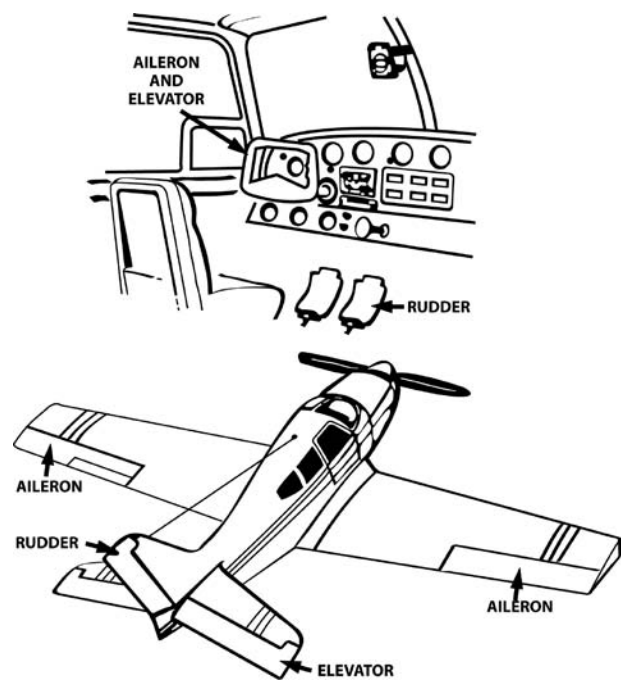

Figure 4

The wing flaps are movable panels on the inboard trailing edges of the wings. They are hinged so that they may be extended downward into the flow of air beneath the wings to create additional lift and drag. Their primary purpose is to permit a slower airspeed and a steeper angle of descent during a landing approach. In some cases partial flaps are used to shorten the takeoff distance. Extending or retracting the flaps has a very noticeable effect on aircraft performance.



# AIRPLANE CAPABILITIES & LIMITATIONS

The flap operating control may be an electric or hydraulic control on the instrument panel, or it may be a lever located on the floor to the right of the pilot's seat. In addition to the flap operating control, there is usually an indicator which shows the actual position of the flaps. On most general aviation airplanes the maximum extent of movement of the flaps is approximately 30 to 40 degrees. (Fig. 5)

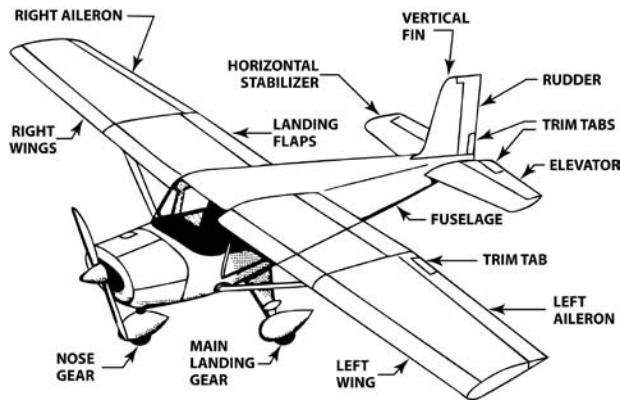

Figure 5

**The throttle controls engine power output.** In side-by-side seating aircraft it is centrally located on the lower portion of the instrument panel. In tandem seating aircraft the power quadrant is on the left wall panel. On some airplanes all the engine controls (throttle, mixture, and propeller) are installed on a separate unit called "engine control quadrant". By means of linkage the throttle is connected to the carburetor to regulate the amount of fuel-air mixture supplied to the engine, controlling the power developed. The power output is increased by pushing the throttle forward and decreased by pulling back. (Fig.6)

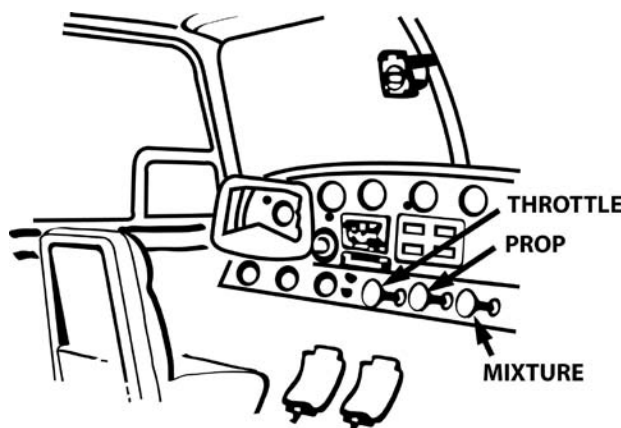

Figure 6

## EFFECTS OF WEIGHT AND BALANCE ON FLIGHT PERFORMANCE

The takeoff and landing performance of an airplane may be determined on the basis of its maximum allowable takeoff and landing weights. **Increased gross weight can be considered to produce a threefold effect on takeoff performance: It requires a higher liftoff speed, the greater mass is slower to accelerate, and it contributes to an increased retarding force (drag and ground friction). A heavier gross weight will result in a longer takeoff run and shallower climb, faster touchdown speed and longer landing roll.** Even a minor overload could make it marginal or impossible for the airplane to clear an obstacle which normally would have not been seriously considered during takeoffs under more favorable conditions. **This is especially true on a hot day and/or high elevation.**

The detrimental effects of overloading on performance are not limited to the immediate hazards of takeoffs and landings. **Overloading has an adverse effect on all climb and cruise performance.** In most airplanes it is not possible to fill all seats, baggage compartments, and fuel tanks, and still remain within approved weight and balance limits. As an example, in typical four-place airplanes, the fuel tanks may not be filled to capacity when four people and their baggage are carried.

The effects of the distribution of the airplane's useful load can have a significant influence on its flight characteristics. The center of gravity (CG) position influences the amount of elevator force required to fly level or "pitch" the airplane. A forward CG (within limits) is more stable, but it can also create a higher drag situation due to additional up-elevator required to maintain flight. **Generally speaking, an aircraft becomes less stable and controllable, especially at slow night speeds, as the center of gravity is moved further aft. The airplane becomes less and less stable as the CG is moved rearward. The recovery from a stall in any airplane becomes progressively more difficult as its center of gravity moves aft.**

Weight and balance control is a matter of serious concern to all pilots. **Before loading the aircraft, indicate individual weights on packages and cargo so the pilot can distribute the weight within weight and balance limits. As aviation managers and users we must understand the importance of providing the pilot with accurate weights of passengers and cargo.** It is a primary responsibility of the pilot to make sure the airplane is loaded within proper center of gravity limits.

# AIRPLANE CAPABILITIES & LIMITATIONS

As discussed in “helicopter capabilities and limitations”, the density of air in which we fly has a significant effect on aircraft capability. **As we increase the elevation and/or the outside air temperature increases, performance decreases.**

As air becomes less dense it reduces power because the engine takes in less air. Thrust is also decreased due to loss of propeller efficiency, and lift is reduced because “thin” air exerts less force on the wings.

When operating from high elevation airports, landing strips, or on hot days, aircraft performance will be dramatically effected. **The airplane at higher elevations will takeoff at the same indicated airspeed as at sea level, but due to the reduced air density, the true airspeed will be greater. This will result in a longer takeoff run and shallower climb.** Accounting for pressure altitude and temperature is necessary for accurate calculation of takeoff distance and climb performance. (Remember, aircraft takeoff and climb performance varies inversely to the altitude and temperature.)

Because of high density altitude, the airplane may have to be “downloaded” by reducing gross weight to stay within weight and balance limits. This can be accomplished by reducing the number of passengers or weight of cargo. Another option is for the pilot to adjust the fuel load of the aircraft to compensate for the number of passengers or cargo. This is always a “tradeoff.” By reducing the fuel load fuel stops may be necessary while en route. In either circumstance, it is necessary for the pilot to have accurate weights. This is the responsibility of the designated aviation manager in coordination with the pilot for that flight. This is the second time density altitude has been discussed in this publication.

A key safety factor is to always operate within the weight and balance limits of any aircraft. Operating out of limits is illegal and dangerous. Remember that no two aircraft, even of the same make and model, will have the same useful load.

Departmental aviation accident statistics have indicated that aviation users can affect the continuing success of the program. By understanding aircraft capabilities and limitations we can make the pilot’s job easier.

All interagency employees have a responsibility to use aircraft safely, efficiently, and effectively. To do so we need to have a foundation on what aircraft can and cannot do.

# SKIPLANE, SEAPLANE, AND FLOATPLANE SAFETY



Figure 1 Skiplane

## THE ENVIRONMENT

Skiplanes (Fig. 1) are used for operations on snow. Locations could include runways, off-airport landings, and unimproved landing areas in other remote locations. The use of skis on planes predetermines a cold environment ahead. Besides being mindful of the ski equipment on airplanes, personnel should also consider the environment in which an unscheduled landing could occur. Snow operations usually take place during the winter months (save for Antarctica) when the amount of daylight is limited. Search and rescue operations possibly will have less time looking for downed aircraft, especially in mountainous terrain. Care should be taken to dress appropriately for the environment which will be flown. Agency policies describe minimum requirements of survival equipment to be carried by aircraft and personnel. These are the minimums; ask the pilot if there are weight restrictions. The density altitude (DA) during snow operations allows greater weight to be carried by the aircraft. Being more prepared for unscheduled landings in cold environments can help keep morale and comfort high. Keep in mind the types of fabric being worn and do not wear synthetic clothing.

### Plain Ski Types

- **Wheel replacement** – Wheels are removed and ski boards are substituted. (Fig. 2)
- **Clamp-on** – Skis that attach to the tires and benefit from the additional shock absorbing qualities of the tires.
- **Roll-on or full board** – Similar to the clamp-on type except the tires are bypassed and do not carry side or torque loads. Only the tire-cushioning effect is retained with this installation.

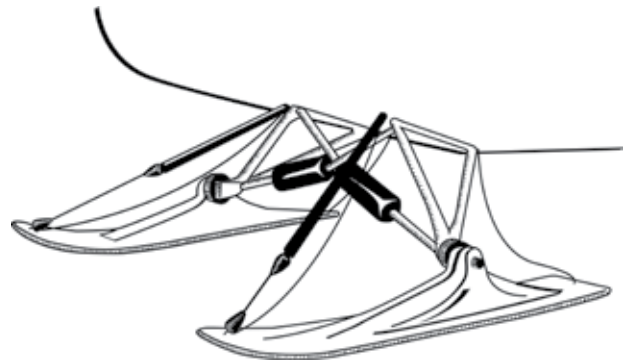

Figure 2 Wheel Replacement Ski.

### Combination Ski Types

- **Retractable ski** – Skis can be extended into place for snow operations or retracted for nonsnow operations. This is accomplished by either a hydraulic pump or crank.
- **Penetration ski** – The wheel extends down partially below the ski, allowing the skiplane to operate from both snow and nonsnow surfaces and causes extra drag when on snow (Fig. 3).

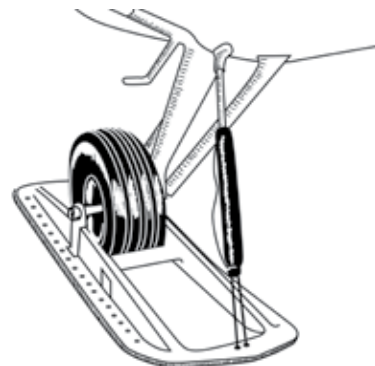

Figure 3 Penetration Ski.

# SKIPLANE, SEAPLANE, AND FLOATPLANE SAFETY

## AIR OPERATIONS

As with seaplanes on floats, agency personnel should plan for slight reductions in cruising speed and range as well as a small decrease in useful loads.

### **Enplaning**

Exercise caution when boarding skiplanes. There can be cables, bungees, hydraulic pistons, hydraulic lines, and other tripping hazards around cabin doors while enplaning.

## COMPONENTS

- **Bungees** – Elastic cords used to rig the ski to the fuselage.
- **Hydraulic lines** – Hoses which house hydraulic fluid to be used as the force between a motor (power-pack) and usually a piston.
- **Hydraulic piston** – Comprised of a rod and cylinder where the rod is either extended or retracted by force of hydraulic fluid coming in or out of the cylinder, respectively.

## SEAPLANE SAFETY

Resource management agencies many times have open bodies of water in their geographic areas. The use of seaplanes to perform agency missions occurs often because of the ability to land and take off on water. A seaplane can include flying boats (also called hull seaplanes) and floatplanes. These terms will be used synonymously to describe any airplane designed to take off and land in water. Agency personnel and other passengers need to be aware of additional considerations specific to seaplanes. An understanding of the parts associated with typical floats and hulls will help passenger situational awareness and safety. See page 24 (Fig. 4, 5, and 6) for diagrams of typical float and hull components and accompanying definitions.

**BILGE** – The lowest point inside a float, hull, or watertight compartment.

**BILGE PUMP** – A pump used to extract water that has leaked into the bilge of a float or flying boat.

**BULKHEAD** – A structural partition that divides a float or a flying boat hull into separate compartments and provides additional strength.

**CHINE** – The longitudinal seam joining the sides to the bottom of the float. The chines serve a structural purpose, transmitting loads from the bottoms to the sides of the floats. They also serve a hydrodynamic purpose, guiding water away from the float, reducing spray, and contributing to hydrodynamic lift.

**CLEET** – Attached to the deck, and used to tie the seaplane to a fixed object (mooring, such as to a dock or buoy) with a rope or chain.

**DECK** – The top of the float, which can serve as a step or walkway. Bilge pump openings, hand hole covers, and mooring cleats are typically located along the deck.

**KEEL** – A strong longitudinal member at the bottom of a float or hull that helps guide the seaplane through the water and, in the case of floats, supports the weight of the seaplane on land.

**SISTER KEELSONS** – Structural members in the front portion of floats lying parallel to the keel and midway between the keel and chines, adding structural rigidity and adding to directional stability when on the water.

**SKEG** – A robust extension of the keel behind the step which helps prevent the seaplane from tipping back onto the rear portion of the float.

**SPONSONS** – Short, winglike projections from the sides of the hull near the waterline of a flying boat. Their purpose is to stabilize the hull from rolling motion when the flying boat is on the water, and they may also provide some aerodynamic lift in flight. Tip floats also are sometimes known as sponsons.

**SPRAY RAILS** – Metal flanges attached to the inboard forward portions of the chines to reduce the amount of water spray thrown into the propeller.

**TIP FLOATS** – Small floats near the wingtips of flying boats or floatplanes with a single main float. The tip floats help stabilize the airplane on the water and prevent the wingtips from contacting the water.

**WATER RUDDERS** – Retractable control surfaces on the back of each float that can be extended downward into the water to provide more directional control when taxiing on the surface. They are attached by cables and springs to the air rudder and operated by the rudder pedals in the cockpit.

**WING FLOATS** – Stabilizer floats found near the wingtips of flying boats and single main float floatplanes to prevent the wingtips from contacting the water. Also called tip floats.

# SKIPLANE, SEAPLANE, AND FLOATPLANE SAFETY

## PASSENGER BRIEFING

### Pilots should brief crewmembers and passengers on:

- Expected landing conditions and actions pilot may request (e.g. seating arrangement in aft center of gravity).
- Use of personal survival equipment and personal flotation devices. Many survivors of accidents recall the inability to gather survival equipment from inside the airplane and were left with what they had on their bodies. DOI personnel should refer to the *Aviation Life Support Equipment Handbook* for survival equipment requirements; Forest Service personnel should refer to vendor contracts for survival equipment requirements.
- Use of personal protective equipment (PPE). Some PPE can be waived. Check with your supervisor.
- Door operations: How to properly open and close in the presence of an imminent emergency.
- Properly securing cargo.
- Unsafe areas around single-engine ski- or seaplanes. At no time are passengers or crewmembers allowed forward of the wing strut on a high wing aircraft or forward of the wing on a low wing aircraft without permission from the pilot.
- Hand holds. The wing struts provide a good hand hold. Many components on an aircraft are not strong enough to serve as handles. Take care not to pull or push on any portion of the aircraft unless you ask the pilot for direction.
- Wet surfaces. Walking on a float deck is much like walking around a boat. Wet areas can be very slippery. Combinations of water, ice, mud, vegetation, and slimy conditions add to the hazards of working around an aircraft.
- Hazards associated with aircraft equipment (e.g., rudder cables, absence of skids). Docking or beaching aircraft.
- Enplaning and deplaning at the discretion of the pilot and only when engine(s) and propeller(s) have come to a complete stop.

Do not board or exit the aircraft until the propeller stops turning completely. There are gruesome casualty stories about persons who have deplaned while the propeller was still turning.

Seaplanes have more limitations to consider than their landplane counterparts. The floats are generally heavier than wheeled landing gear. Cruise speed, aircraft range, and useful load are all decreased to a degree. Fuel consumption is increased which makes good planning pertinent as there are less refueling

options when the aircraft is mounted with floats.

### Other suggestions:

Learn emergency egress principles. A capsized seaplane filling with water can be more disorienting without training.

It is recommended agency personnel attend interagency water ditching training prior to seaplane operations.

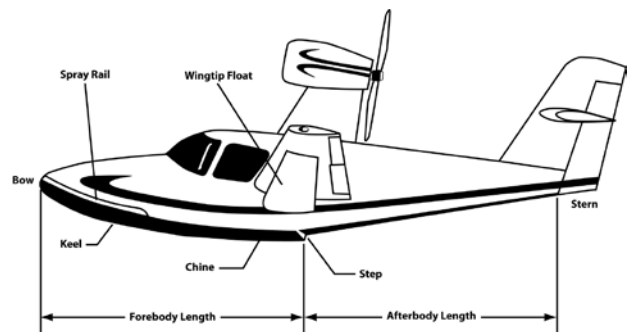

Figure 4 Seaplane

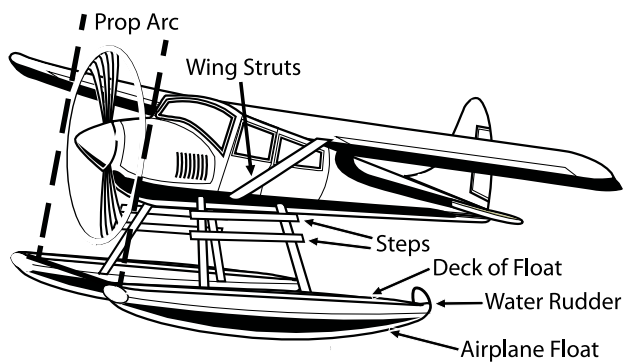

Figure 5 Floatplane

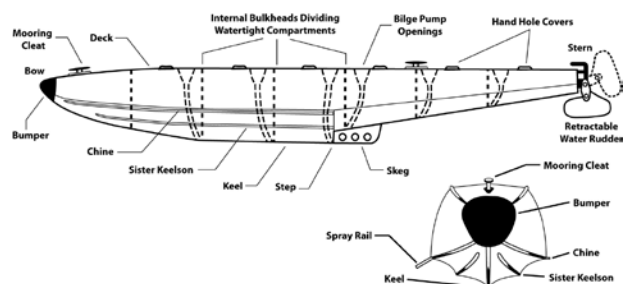
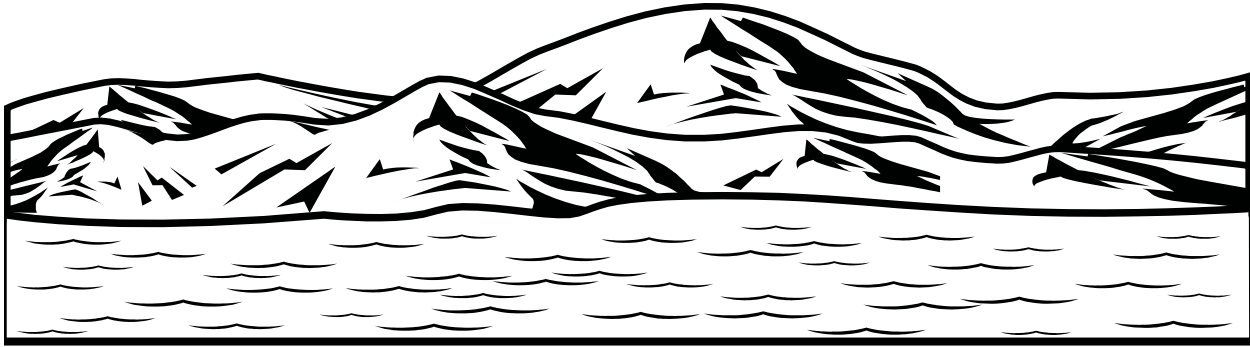

Figure 6 Float Components

# FLYING IN REMOTE LOCATIONS



## Note:

Much strife has arisen over terms such as: back-country, off-airport, category IV, bush, and landing strip among pilots and other users of these places. For the purposes of this booklet these terms are meant to describe those airports and heliports/ spots which are removed from operating control towers and many times asphalt/concrete. This booklet uses the term “remote environment” to ambiguously mean all of the above.

Many missions carried out by land management agencies happen in, around, or over remote environments. The remote environment can be any location removed from airports having services. Remote environments can have mountainous terrain features which alter the flow of air. These changes in the local winds can produce updrafts, downdraft, and/or moderate to severe turbulence. These conditions can severely limit the control of aircraft if encountered. Furthermore, aircraft flight in remote environments can involve being at higher altitudes for takeoffs and landings. Density altitude (DA) is the atmospheric condition where high temperatures and high elevations lead to less dense or “thinner” air. Working in areas with high DA requires special consideration in regard to aircraft performance and cargo limitations. Density altitude is the altitude the aircraft “thinks” it is at. For example, on a 95 F degree day an airport at an elevation of 6,000 feet MSL can have a density altitude of 9,600 feet MSL. This means the aircraft will perform as if it really were at 9,600 feet MSL. At the same airport on a 20 F degree day the density altitude could be 4,900 feet MSL or even less, again mostly depending on temperature, and the same aircraft would perform as if it were at 4,900 feet MSL.

**Performance limitations.** Aircraft performance is greatly affected by density altitude and aircraft weight. The propellers, wings, rotors and engines (nonturbo charged) of aircraft all have decreased performance because of thinner air at high density altitudes. Higher density altitudes will require a longer takeoff roll for airplanes and more power for helicopters. For example, at a high elevation airstrip on a hot summer day there may be enough runway for an airplane to land but not enough runway for that

airplane to takeoff. Helicopters may also have trouble getting airborne especially when that helicopter is near its gross weight limits. Even if both of these aircraft are able to become airborne, further consideration must be given to their climb performance. Will an aircraft be able to safely climb out over rising terrain with the weight aboard?

**Cargo limitations.** One way to deliver all of the required cargo could include making several shorter trips. Staging passengers and cargo at nearby locations relative to the destination and conducting shorter flights will decrease the weight on each trip which allows the aircraft greater performance. Consider conducting flight operations in the cooler periods of the day when appropriate. Another possibility to improve the performance of the aircraft is to carry minimal cargo and equipment. On any mission carry only the required survival and safety equipment for personnel and the aircraft plus the cargo needed for the mission. Carrying excess weight results in longer takeoff rolls, decreased rate of climb, higher fuel burn, and greater stall speeds for airplanes. More power for takeoff, greater fuel burn, decreased rate of climb, tail-rotor effectiveness, and less available power are the affects and considerations of higher gross weight for helicopters.

Maintaining aircraft performance can be done by adjusting the fuel load to maximize efficiency for each mission. Increasing cargo/passenger weights as fuel is consumed during missions proves to be a common strategy. Ask yourself: “Is it possible to refuel during the mission?” Doing so can improve aircraft performance by reducing the aircraft weight or allowing additional equipment aboard the aircraft. Every flight requires a preflight briefing. Check with the pilot to find out the limitations for the day’s flight(s) and how best to work with the agency’s mission objectives. Atmospheric conditions are the largest variable in aviation-related operations.

We hope interagency personnel take care to properly plan for aviation-related missions. Doing so will help cultivate safety in the interagency aviation community and beyond.

# EMERGENCY LOCATOR TRANSMITTER (ELT)

## COSPAS-SARSAT SATELLITE SYSTEM

The National Environmental Satellite, Data and Information Service (NESDIS) of the National Oceanic Atmospheric Administration (NOAA) of the Department of Commerce manages all United States civil operational earth-observing satellite systems. NESDIS operates geostationary and polar-orbiting satellites that monitor daily weather and surface conditions over the entire globe. The COSPAS-SARSAT satellite system is sponsored by the European Space Agency, India, Russia, and the United States (Fig. 1).

COSPAS-SARSAT is being used in an international cooperative search and rescue satellite effort. The COSPAS-SARSAT project objective is to help save the lives of aviators and mariners who are in distress and transmit emergency signals to satellites that pass above them. Aircraft carry fixed Emergency Locator Transmitters (ELT) which normally are triggered by the impact of the crash. Ships and boats carry floating Emergency Position Indicating Radio Beacons (EPIRB) that are activated by immersion in water. Both the ELT and EPIRB can also be activated manually. Another device, personal locator beacons (PLB), serves people in outdoor environments in the same manner as the other beacons. During preflight briefing, instructions should be given to crew and passengers on proper manual activation of ELT and EPIRB units.

The common operational COSPAS-SARSAT ELT radio frequency is 406 Megahertz (MHz). This frequency provides the location of an aviator or mariner in distress with an accuracy of 1 to 3 miles (the older 121.5 MHz signal had an accuracy of 12 to 15 miles). The 406 MHz beacon transmits a digital identification number containing information unique to that particular beacon such as identification, type of vehicle (aircraft or surface vessel), and country code. If the ELT or EPIRB has GPS capabilities, or location protocol, it will transmit precise geographic location in addition to the identification number.

**Note: Without prior registration through NOAA, immediate response may be delayed by SAR forces.**

## HOW SATELLITES HELP SAVE LIVES IN THE UNITED STATES

- Aviators and mariners in distress use an ELT (Fig. 2, pg. 27) or EPIRB to transmit an emergency signal to the SARSAT and/or COSPAS satellites.
- The ELT or EPIRB emergency signal is received by the SARSAT and/or COSPAS satellites. The satellite retransmits the ELT or EPIRB emergency signal to a ground-receiving station called a Local User Terminal (LUT).
- The LUT receives the ELT or EPIRB emergency signal from the SARSAT and/or COSPAS satellite. The ELT or EPIRB emergency signal is processed and the location of the aviator or mariner in distress is recorded.
- The LUT passes the location of the aviator or mariner in distress to the U.S. Mission Control Center (USMCC) at Scott Air Force Base, Ill. The USMCC sends the location of the aviator or mariner in distress to the proper land or sea Rescue Coordination Center (RCC).
- The location of people in distress on land is given to U.S. Air Force RCCs. The location of people in distress at sea is given to U.S. Coast Guard RCCs.
- Search and Rescue (SAR) forces are sent out by either the U.S. Air Force or the U.S. Coast Guard. SAR forces include fixed wing aircraft, helicopters, ships, boats, ground search parties, and may include commercial airlines or commercial ships.
- The SAR forces find the aviators or mariners in distress, bring them to safety, and switch off the ELT or EPIRB.

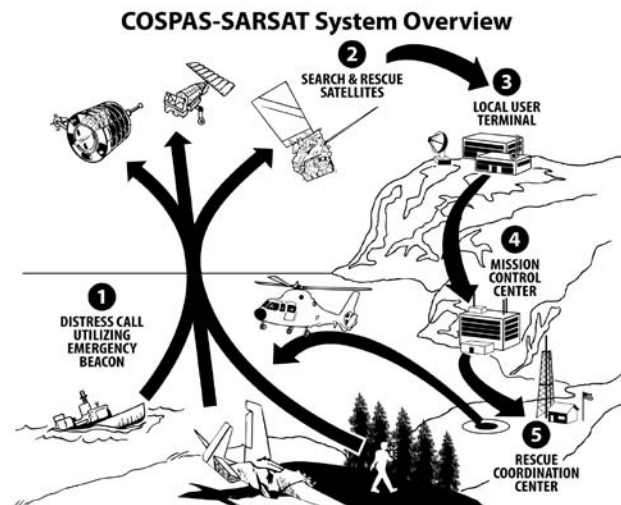

Figure 1

# EMERGENCY LOCATOR TRANSMITTER (ELT)

## LOCAL USER TERMINALS

There are **45** LUTs operating as of **2009**. The LUTs are located in **about 30 countries worldwide and more are being developed every year**. The entire world is covered and ready to receive ELT and EPIRB emergency transmissions on a radio frequency of 406 MHz.

**The tracking of COSPAS-SARSAT satellites gives the 406 MHz frequency global coverage.**

## FALSE ALARMS

The majority of ELT and EPIRB emergency transmissions at the LUTs are false alarms. False alarms waste valuable search and rescue time that could be used for a real emergency situation. Newer 406 MHz units help reduce the number of false alarms which also helps keep SAR costs down. Aviators and mariners can help stop false alarms by doing the following:

- The ELT and EPIRB beacons should be mounted properly.
- ELT and EPIRB beacons should be maintained regularly.
- ELT and EPIRB beacon batteries should be disconnected when the unit is not regularly used, or being shipped or disposed of.
- Familiarize yourself with ELT and EPIRB operating instructions before having to use the unit in an emergency situation.
- Have maintenance personnel perform testing of beacons in accordance with manufacturer's recommendations.

## EMERGENCY LOCATOR TRANSMITTER (ELT)

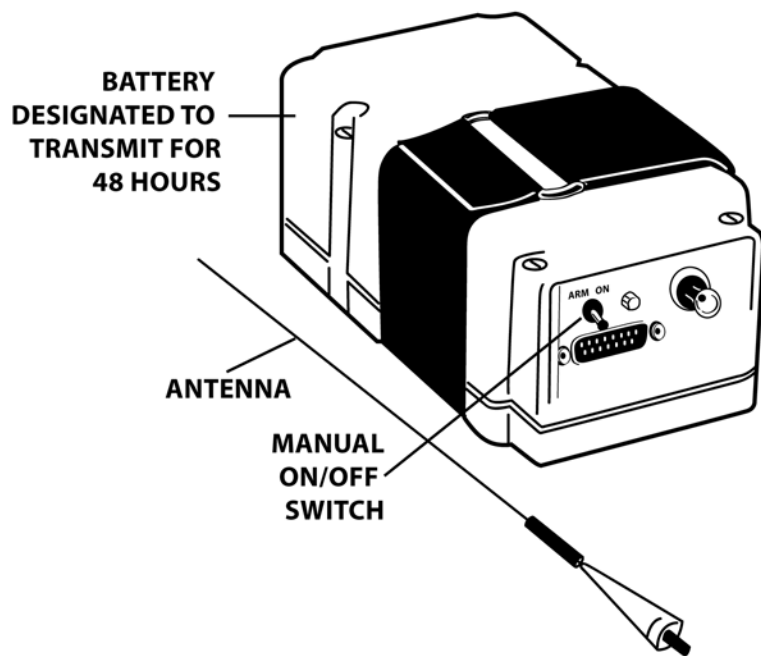

Figure 2

For additional information contact:

NOAA, Search and Rescue Satellite Aided Tracking Program:  
1-888-212-7283  
<http://www.sarsat.noaa.gov/>



# HELICOPTER HAND SIGNALS



**CLEAR TO START**  
Make circular motion  
above head w/arm



**HOLD ON GROUND**  
Extend arms at 45°  
thumbs down



**MOVE UPWARD**  
Arms extended  
sweeping up

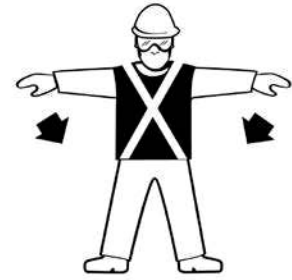

**MOVE DOWNWARD**  
Arms extended  
sweeping down



**HOLD HOVER**  
Arms extended  
w/clenched fists

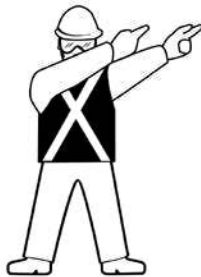

**CLEAR TO TAKEOFF**  
Arms extended in  
takeoff direction



**LAND HERE**  
Extend arms  
w/wind at back



**MOVE FORWARD**  
Arms extended and  
wave copter toward you



**MOVE REARWARD**  
Arms downward  
using shoving motion



**MOVE LEFT**  
Right arm extended  
left arm sweeps overhead



**MOVE RIGHT**  
Opposite of  
move left



**MOVE TAIL ROTOR**  
Rotate body w/one  
arm extended

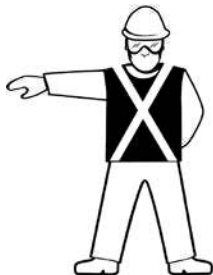

**SHUT OFF ENGINE**  
Cross neck w/hand  
palm down



**FIXED TANK DOORS**  
Open arms outward  
Close arms inward



**RELEASE SLING LOAD**  
Contact forearm  
w/other hand

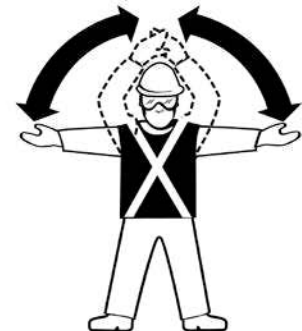

**WAVE OFF DON'T LAND**  
Wave arms and  
cross overhead









# Interagency Aviation Safety Alert



No. IA SA 13-01

Date: May 22, 2013

Page 1 of 2

**Subject: Helicopter Brace For Impact Positions**

**Area of Concern: Helicopter Operations**

**Distribution: All Fire and Aviation Operations**

**Discussion: “BRACE FOR IMPACT”** These are three words that you never want to hear when flying in an aircraft, but will assist you in preparing yourself for a crash sequence if one were to occur. This communique was developed due to the inconsistent information within various manuals and training materials.

Body position at the time of impact is an important factor in making an accident survivable. The two primary reasons for bracing are to reduce secondary impact and flailing injuries. Secondary impact injuries can be reduced by repositioning the body (particularly the head) against the surface it would normally strike during impact. When using a shoulder harness, secondary impact with the structure will likely involve the head, thus the importance of head positioning.

Flailing can be reduced by proper body positioning and gripping the seat edge with your hands or placing them under your legs. **DO NOT** grasp the restraint harness. If your seat is equipped with non-inertial reel-type shoulder harnesses, make sure you tighten the shoulder harnesses as much as possible.

Dr. Richard Chandler, of the Protection and Survival Laboratory, FAA Civil Aeromedical Institute was instrumental in developing the brace for impact seating positions used by government and commercial aviation industry. Based on his work, the following brace for impact positions are being implemented:

Forward facing seats:

- Press your lower torso firmly against the seat back.
- Lower your chin to chest.
- Grip the seat edge with your hands or place them under your legs. **Do not grasp the restraint harness.**





#### Rear facing seats:

- Press your lower torso firmly against the seat back.
- Place your head back against the head rest or bulkhead.
- Grip the seat edge with your hands or place them under your legs. **Do not grasp the restraint harness.**



#### Side facing seats:

Unfortunately, no formidable brace for impact position has been developed for this particular seat configuration. Based on the anti-flail and secondary impact philosophies previously described, it's recommended that you lean toward the front of the aircraft and brace your upper torso and head against whatever might be contacted, or moving the head in the direction of impact to reduce flailing.

This information supersedes guidance within **DOI Operational Procedures Memorandum (OPM) 13-48 (OPM)** and the **2013 Interagency Helicopter Operation Guide (IHOG), Ch. 10, Exhibit 10-1 (IHOG)**. Updates to these documents will be made to reflect the new procedures during its next revision cycle. Additionally, current aviation safety courses covering helicopter impact positions will soon be revised as well.

#### References:

- \*FAA AC 91-32B Safety In and Around Helicopters, June 1997
- \*FAA AC 121-24C Passenger Safety Information Briefing and Briefing Cards, Appendix 4, 7/23/03
- \*Transport Canada Commercial and Business Aviation Advisory Circular 0155, May 1999
- \*Dr Richard Chandler – Protection and Survival Laboratory, Civil Aeromedical Institute, FAA, February 1988
- \*Flight Safety Foundation - Cabin Crew Safety, Positions Brace Passengers for Impact To Reduce Injuries and Fatalities, January/February 1988
- \*Air Carrier Operations Bulletin 1-94-17, Brace for Impact Positions

*/s/ Keith C. Raley*

---

Keith C. Raley  
Chief, Aviation Safety  
and Program Evaluation

*/s/ Gary Sterling*

---

Gary Sterling  
Acting Branch Chief, Aviation Safety  
Management Systems