

THE COLUMBIAN GROUND SQUIRREL  
ITS BIOLOGY AND CONTROL



**MONTANA DEPARTMENT OF AGRICULTURE  
BOX 200201  
HELENA, MT 59620-0201**

# THE COLUMBIAN GROUND SQUIRREL ITS BIOLOGY AND CONTROL

## BIOLOGY

Columbian ground squirrels (*Urocyon columbianus*; formerly *Spermophilus columbianus*; Fig. 1) are medium-sized burrowing rodents found in Montana from the east slope of the Continental Divide westward (Fig. 2). They are found in mountainous areas above the tree line to the valleys. Columbian ground squirrels usually avoid dense forest areas but will inhabit areas with open forest and along forest edges. They avoid areas with wet soils, preferring the sloped ground of banks, and hillsides.



Figure 1. Columbian ground squirrel.

Columbian ground squirrels are easily distinguished from other Montana ground squirrels by their larger size and distinctive coloration. Columbians have reddish-brown fur on the nose, forelegs, and hindquarters, while the back and upper limbs are mottled gray and brown. Adults measure 13 to 17 inches in length including their bushy tails which average three to five inches. Columbians usually weigh more than a pound as adults and become sexually mature at the age of two.

Columbian ground squirrels emerge from hibernation by late March and early April in most areas (Figure 3). Snow cover, soil temperature, weather conditions and elevation will affect the time of emergence from hibernation. Emergence also may vary within small areas due to microclimate

differences caused by slope and snow cover. For instance, squirrel colonies located on south-facing slopes or flat areas may emerge one to three weeks before a colony located on a north-facing slope in the same area. Males emerge from hibernation about one to two weeks before the females.

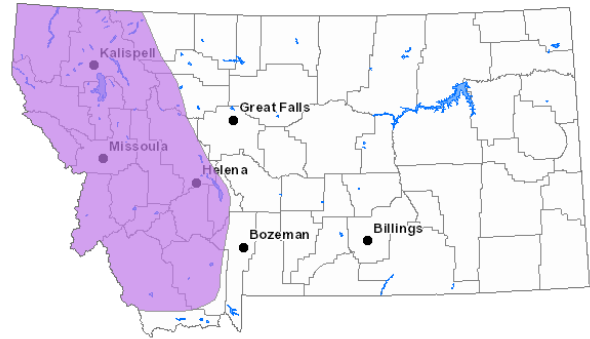

Figure 2. Range of the Columbian ground squirrel in Montana.

Males exert their dominance by establishing territories, typically about a half an acre, and aggressively driving out competing males between April and May. Males continue this behavior into summer but with less intensity. Breeding begins shortly after the females emerge and continues for two weeks. One male may breed with more than one female and females with more than one male. After the breeding period, mated females prepare the nest and spend much of their time during late gestation and early litter rearing in the burrow and are relatively inactive above ground. Columbian ground squirrels have a gestation period of about 24 days and have one litter per year of two to four young. Litters are larger and more variable in size at lower elevations than at higher elevations. The young, born helpless and dependent on their mother, emerge from the burrow at about four weeks of age. They begin foraging on vegetation soon after emergence. They are weaned and independent from their mother at, or shortly after, emergence from the burrow. By late summer, juveniles reach about 60 percent of the average adult weight.

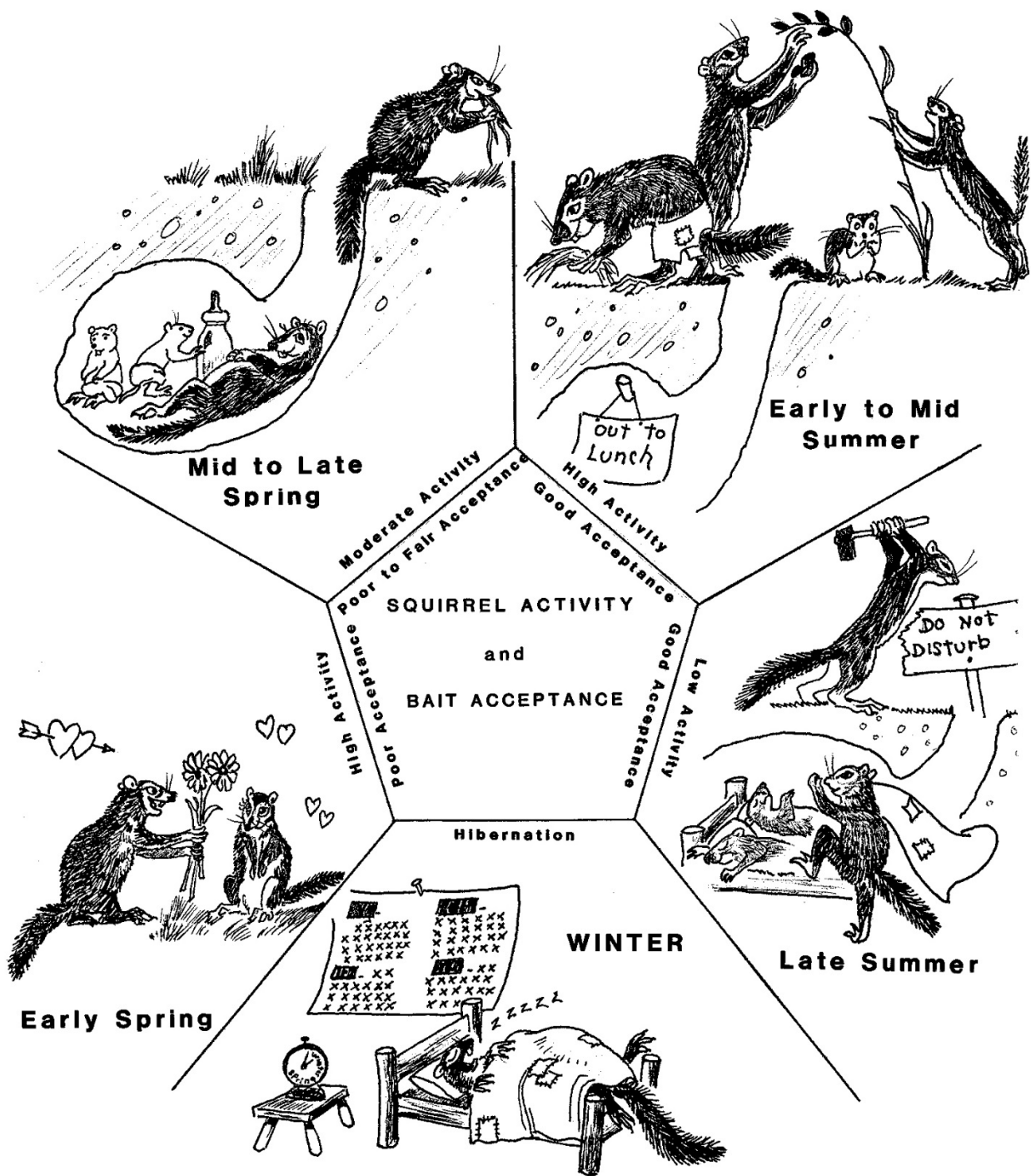

Figure 3. Life of the Columbian ground squirrel.

Columbian ground squirrels often are described as selective and picky eaters. Though they eat a wide variety of vegetation, including grasses and forbs, they generally select the most succulent species. As vegetation develops seeds, squirrels include them in their diet as well as, their high caloric and oil content aids in the accumulation of body fat needed to carry

them through hibernation. Seeds are hulled and eaten individually much of the time.

Green vegetation continues to be an important dietary component because, in most cases, it is the squirrels' only source of water. Columbians tend not to pouch food in their cheek pouches and little food

is stored in their burrows. Interestingly, squirrels will supplement their diet by feeding on insects and carrion as opportunities arise.

Ground squirrels seem to have difficulty maintaining their body temperature during cold or hot periods. During cold, inclement days they spend more time in their burrows. When days are hot, squirrels emerge during the cooler parts of the day (i.e., mornings and late afternoons). Squirrels exposed to hot temperatures for more than a few hours are likely to die.

In June and July, a large percentage of yearling males and a few yearling females will disperse from the area they were born and find new territories. Most movements are less than 55 yards, but ground squirrels have been recorded as traveling over 1.3 miles. Columbian ground squirrels enter hibernation in late summer, beginning in August, in response to drying vegetation and high temperatures. Squirrels at lower elevations enter hibernation before those at higher elevations. Juveniles typically hibernate within proximity of their mother and siblings. The majority of local population enters hibernation within a one to two-week period. Small numbers of squirrels, usually young of the year, may be seen several weeks after most of the population has begun hibernation. Hibernation begins around August 15 but specific times vary by location and weather conditions. Squirrels hibernate in their own individual grass lined pocket (called a hibernaculum) below the frost line (typically 11 to 26 inches below the soil surface; Figure 4). They neither eat nor drink, living on body fat accumulated during the summer. Body temperature drops to about 38° to 42° F during hibernation. Bodily functions are greatly reduced, allowing the squirrels to slowly use their accumulated fat. Squirrels arouse periodically to eliminate small quantities of accumulated body wastes.

#### **DAMAGE**

In their native and undisturbed habitats, ground squirrels provide key benefits. Their burrowing and digging activities increase habitat diversity resulting in complex interdependent plant and animal communities. Columbians do help suppress the spread of the invasive weed Yellow Salsify

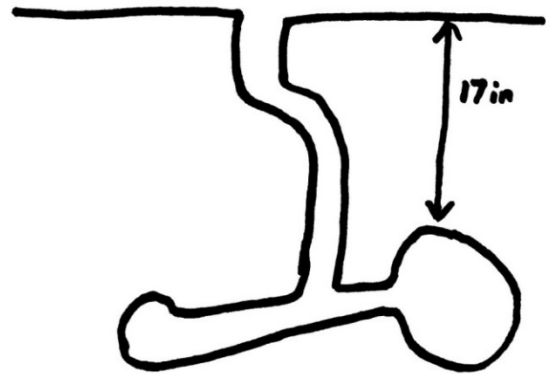

Figure 4. Drawing of a typical hibernaculum used by a Columbian ground squirrel.

(*Tragopogon dubius*). Burrowing and other digging activities assist in soil development, soil aeration, and moisture retention. Columbian ground squirrels are also an important food source for many predators including badgers, weasels, coyotes, foxes, and birds of prey. Badgers are probably the most consistent and successful predator on Columbian ground squirrels. Juveniles are likely the most vulnerable targets for hawks, foxes, and coyotes.

Unfortunately, the presence of Columbian ground squirrels can have significant impacts on agricultural production. Ground squirrels can inhabit forage crop areas, such as alfalfa, pasture lands, rangelands and non-forage crop areas, such as wheat and canola, where they damage plants by feeding, burrowing and trampling (Figure 5).



Figure 5. Loss of production around the Columbian ground squirrel burrows.

Burrows can also contribute to increased soil erosion and provide sites for undesirable weedy plants to grow and/or degrade the landscape's beauty. Research by the MDA on 91 burrows found that burrows averaged four openings (range 1-9) per

system with an average radius of 12 feet (range 0-28 feet). One researcher estimated that 355 ground squirrels consumed as much forage as a cow each day and 96 ground squirrels were the foraging equivalent of one sheep. To estimate the potential impact of Columbian ground squirrel presence on agricultural production, use the following survey technique. In April, before the emergence of young, observe a field for five minutes and count the number of ground squirrels you see. Multiply that number by 0.25 and the result will be the percentage of crop you can expect to lose in the first harvest. Squirrel mounds can cause costly equipment damage to machinery used to harvest forage crops or reduce production and available forage for livestock (Figure 6).



Figure 6. Mounds of excavated soil can damage harvesting equipment.

When ground squirrels reside in uncultivated border areas, their feeding on nearby crops can significantly reduce production in adjacent areas. Burrowing activity in dikes and embankments can lead to breaches that threaten public safety. It is strongly recommended that ground squirrels be removed from dikes and sensitive embankments as allowing ground squirrels to continue to burrow for as little as two to five years can cause the structure to collapse.

Researchers have recorded ground squirrel densities of 12 per acre in wheat fields, 30 per acre in bottomlands, and 18 per acre in subalpine rangeland. Density of ground squirrel populations can vary significantly with better habitats containing as many as three times as many ground squirrels than less favorable habitats.

## CONTROL METHODS

Ground squirrel numbers can change dramatically from year to year. Severe winter and spring weather can significantly reduce ground squirrel numbers

through weather-related mortality. Likewise, favorable environmental conditions, particularly over a two-year period, can permit high numbers of ground squirrels. Research has shown that changes in ground squirrel numbers can be most pronounced in populations residing in lower elevations. Food availability can also impact ground squirrel numbers. Landowners are encouraged to monitor the landscape in conjunction with environmental conditions with an eye on how these events may help them anticipate high ground squirrel numbers and the need to implement control measures.

### A. Cultural & Biological

Cultural and biological controls are important parts of an integrated control approach and should be implemented whenever feasible. Though inadequate to control ground squirrel damage by themselves, cultural and biological controls often magnify the effectiveness of other control methods. Employ frequent crop rotation or tillage of the soil to disrupt food patterns and damage burrow systems in crop areas. Disturbing the availability of food to Columbian ground squirrels will impact the growth rate of the population and can even reduce the population overall. Where practical, flood irrigation will eliminate ground squirrels from affected fields. Be prepared, however, to initiate control efforts on unmanaged border areas as the squirrels can still cause severe damage to crops along field edges. Flooding of individual burrows can take a fair amount of water and time because ground squirrels build dens with a drainage pit to direct water away from the living area. The time needed to flood the den would be better spent on more efficient control methods.

Coyotes, fox, weasels, raptors, badgers, skunks, snakes and other predators prey upon ground squirrels and other rodents. While not able to eliminate rodent damage, predators contribute to the overall control effort by reducing population spikes in ground squirrels and their presence should be encouraged. Installation of poles for raptors to perch on can be an easy way to encourage their presence. Since raptors are territorial, place poles no closer than one every 10 acres. Additionally, raptors prefer tall poles so endeavor to install ones that will be at least 23 feet or higher.

Destroy the dens of ground squirrels, through deep plowing or other means, whenever practical. Research suggests that population control fails largely due to ground squirrels in the surrounding

area immigrating and reoccupying empty dens. For best results, destroy dens down to at least 18 inches in depth. A device called the BurrowBlocker™ creates a slurry of water and masonry sand to fill burrows. The device is expensive and has not undergone rigorous scientific review, but its use may reduce reoccupation of abandoned burrows.

### **B. Shooting**

Shooting with .17 HMR, .22, shotgun, or pellet rifle, may provide some relief from ground squirrel damage. But the cost, in time and bullets, often makes shooting practical for small acreages or as a follow-up or maintenance control method to other control practices. One report found that shooting only achieved a five percent reduction with two hours of effort per acre. However, results in your locale will depend on shooter proficiency and effort. Producers can avoid these costs using recreational shooters. Efficacy of shooting as a management tool can be substantially improved by shooting in March-April before young emerge.

Since scavengers and predators will feed on the dead carcasses, reduce the risk of poisoning them with lead by using non-toxic bullets. Alternatively, pick up carcasses and dispose via deep burial. Always wear protective gloves or use tongs when handling ground squirrel carcasses to reduce exposure to fleas and other disease carrying organisms. Employ safe shooting practices and abide by all local and state regulations.

### **C. Trapping**

Traps are best suited for removal of small (<10 acres), local populations of ground squirrels where other control methods are undesirable. Such areas would include public parks, schools, cemeteries and private yards. Trapping is an effective control method and no license is required. While trapping can occur any time Columbians are active, it is most successful within 30 days of emergence from hibernation (i.e. March) or in July.

Body-gripping traps, such as GT2006 by Lee's Trap Works, #55, #110 conibear-style traps along with the 2.5 or 3.5 RBG round-conibear style traps are, durable, and easy to use. Set traps directly in front of or over entrances to active burrows with the trigger-bearing jaw positioned furthest from the entrance. Stake traps securely. A 24-inch rebar stake works well. Use the first foot to secure the trap and the second foot will be high enough above ground to allow the trap to be located. Ensure traps are stable

by wedging them in the hole or by inserting one or two stakes or dowels at an angle between the jaws of the set trap (Figure 7).



Figure 7. A #110 conibear-style trap set over a den hole.

Use of a conibear-safety gripper will protect against accidental closing while setting the trap. Just be sure to remove it before you leave. Bait is not necessary as the traps are triggered by the animals' normal movement. Although generally safe, non-target animals, such as weasels, badgers, and skunks, can be injured or killed.

Choker-style traps such as the DK-2 or Gopher Getter, like the conibear-style traps will kill the ground squirrel but, like the cage traps, must be baited. Since they are baited-kill traps, use them in areas where non-target animals will not be able to access traps. Bait should never be visible to birds flying overhead. Also ensure they are adequately anchored as scavengers will carry off the trap with the dead squirrel.

Cage traps (16 x 5 x 5 inches or larger) may be baited and set in areas frequented by ground squirrels. Squirrels are easily caught using grains, such as whole or rolled oats, sunflower seeds, peanut butter, fresh fruit, vegetables or greens. Experiment to find the best bait or combination of baits for your area and time of year. Wiring the door of the trap open for 1 to 2 days while replenishing the bait daily helps overcome the squirrel's trap shyness and increases trapping success. Stake traps to the ground to prevent dogs and other predators from carrying off the traps containing ground squirrels. Predators also may maul captured ground squirrels. If dogs or other predators are a problem, monitor the trapping area carefully. Ideally, check traps in the morning and at dusk. Note that squirrels may die of heat stress when caught in cage traps exposed to the sun. For this reason, cage traps (as well as solid-walled versions)

should be shaded and the captured squirrels humanely killed.

Montana wildlife laws do permit the translocation of Columbian ground squirrels to public lands. You may translocate ground squirrels to private land provided the landowner gives permission. Release sites should be at least 10 miles away and have habitat suitable habitat for Columbian ground squirrels.

Understand that while translocation appears humane, it is extremely stressful on animals who must now find food, shelter while avoiding predators and competition with animals already in the location. If you choose to translocate, endeavor to release the squirrel in the morning to give it time to orient itself before nightfall. Never translocate a ground squirrel that appears ill to avoid spreading a disease to a new location.

#### **D. Carbon Monoxide Generators**

Carbon monoxide generators are devices that use the exhaust from a gasoline powered engine to fumigate rodent burrows. As devices, a license is not required to use these machines. Applicators should follow manufacturer guidelines as carbon monoxide is a highly toxic gas. Applicators are encouraged to avoid fumigating burrows within 20 feet of structures to reduce the risk of exposing occupants to the toxic gas. MDA research has found that burrows should be fumigated at least 4 minutes and perhaps longer to obtain control as our research using a three-minute injection time achieved less than 40% control. There are several different devices on the market including The Cheetah, BurrowRx, Rascal Eradicator®, CO-Jack, and the P.E.R.C. (pressurized exhaust rodent control). Applicators are encouraged to thoroughly evaluate the features of these devices before purchasing.

#### **E. Burrow Fumigants**

Burrow fumigants are products that release toxic gases when used in a burrow system. Labor and cost of materials usually restrict the use of fumigants to small acreages (e.g., <10 acres) or sparse populations. They are recommended as a cleanup method after the use of toxic bait or in areas where use of toxic baits is inadvisable. Plan to apply fumigants near dusk to ensure ground squirrels are in their dens. Never use fumigants near structures or where people and domesticated and wild animals may be exposed to the fumes.

**Ignitable gas cartridges** are the most commonly used burrow fumigant as they are registered as general use pesticides. After the fuse is lit, the cartridge is placed well down into the burrow. As the cartridge burns, toxic gases, primarily carbon monoxide, consumes the available oxygen in the burrow. Plug the burrow opening with sod and seal with soil by tamping down tightly with a shovel. Any adjacent burrow openings emitting smoke should be plugged with soil. Application of ignitable gas cartridges is most effective after the ground is moistened by rain or irrigation. Moist soil holds the toxic gas better than dry soil and reduces the risk of fires that can result from use of ignitable cartridges. Researchers in one study took 44 man-hours to treat 10 acres and achieved a control rate of 72 percent.

Carbon dioxide (CO<sub>2</sub>) is a recent addition to the fumigation toolbox. Liphatech, Inc.'s IGI Carbon Dioxide™ product (EPA# 91274-1) is registered to dispense bottled CO<sub>2</sub> to control pocket gophers, ground squirrels, rats, and voles. It may even be applied in burrows near structures. The Vertebrate Pest Specialist welcomes comments from applicators about their experience with this product.

**Aluminum phosphide** (AP) is a highly toxic pesticide. It may only be used by certified applicators on burrows at least 100 feet from structures. In addition, applicators must create a written fumigation management plan (FMP) prior to any application (additional details below).

Aluminum phosphide tablets or pellets (a tablet releases about five times as much gas as a pellet) are restricted use pesticides due to the highly toxic nature of phosphine gas that is released in the presence of moisture. Since phosphine gas will react to skin moisture, as well as be absorbed through the skin, always wear the personal protective equipment (PPE) required on the label and stand upwind during applications. Open canisters only in well ventilated areas, such as outdoors and with the opening directed away from your face. Secure canister lids when not in use and store in a dry area not accessible or inhabited by humans, pets, or livestock. Follow label instructions carefully.

The label permits application of up to four tablets or 20 pellets for each active burrow, but you are likely to achieve control with half that amount. If soils are very dry, consider using three tablets or 15 pellets per active burrow. Place tablets/pellets deep enough to prevent their being smothered with soil when the

entrance is sealed. You may find that using a length of 1- to 2-inch diameter plastic pipe is helpful in placing tablets/pellets deep into the burrows. After removing the pipe, plug the burrow opening with crumpled newspaper or sod (this prevents the tablets/pellets from being smothered with soil), seal the hole with soil and tamp tightly with a shovel. Treat every opening of the active burrow.

### Caution

Read pesticide labels carefully BEFORE applications as use restrictions can vary significantly amongst pesticide labels. The information in this document does not replace the information on the label. Remember, THE LABEL IS THE LAW.

NOTE: Many significant changes have occurred recently (2012) on the labels of all aluminum phosphide products when used as burrow fumigants for rodent control. Some of these changes include:

1. Completion of a detailed written Fumigant Management Plan (FMP) is required prior to the application of fumigant. The Montana Department of Agriculture has created a FMP template to help applicators fulfill the FMP requirement, visit <https://agr.mt.gov/Vertebrate-Pests>.
2. Prior to applying aluminum phosphide to rodent burrows, the applicator must provide the customer with a copy of the completed FMP.
3. Aluminum phosphide fumigant use is strictly prohibited for fumigating rodent burrows on single or multi-family residential properties and nursing homes, schools (except athletic fields), day care facilities and hospitals.
4. Aluminum phosphide fumigants cannot be applied into a rodent burrow system that is within 100 feet of a building that is or may be occupied by humans and/or domestic animals.
5. A phosphine gas monitor must be used when handling or for all applications of aluminum phosphide burrow fumigants to ensure that exposure to phosphine gas does not exceed 0.3 ppm for the eight-hour time weighted average (TWA) or the 15-minute short term exposure limit (STEL) of 1.0 ppm. If these levels are exceeded, vacate the treated area until phosphine gas is reduced below these levels. If it is necessary for someone to remain in the treated area when phosphine gas exceeds these levels, a self-contained breathing apparatus of the type required by the label must be worn.

Other restrictions and regulations are presented on the updated aluminum phosphide labels. Be sure to read and follow the entire label, which includes the label on the container and the supplemental applicator's manual.

Burrow fumigants work most effectively when soil moisture is high enough to contain the gasses within the burrow. Effectiveness will decrease when fumigants are used in dry, sandy, or gravelly soils. For best results, fumigate in the spring after soil soaking rains or after irrigation.

### F. Grain Baits

The Columbian ground squirrel is a difficult species to control with toxic grain bait. Its apparent preference for green foods and suspiciousness of unnatural food sources often leads to poor acceptance of grain baits. Nevertheless, direct population reduction with toxic bait is the most practical method of ground squirrel control on larger acreages. At the time of publication, only three active ingredients for baits (zinc phosphide, diphacinone and chlorphacinone) are available for the control Columbian ground squirrels in Montana. As the status of rodenticides changes, we suggest periodically checking the registered products list by visiting <https://mtplants.mt.gov/ProductRegFSA/BrandSearch.aspx>.

**Zinc phosphide** is an acute toxicant applied to grain. Due to its high toxicity, zinc phosphide baits have numerous restrictions to protect endangered species. Species particularly applicable to Montana include whooping cranes and black-footed ferrets. Label instructions on the application of zinc phosphide to control ground squirrels vary significantly. For example, in rangelands, pastures, and adjacent non-crop areas, some labels may require that zinc phosphide treated bait be applied within a 6-inch circle within 3 feet of active burrows. Other labels simply say the bait must be placed around active burrows and others allow broadcast baiting. In alfalfa fields, bait is applied underground (meaning inside the burrow) or in bait stations post-harvest or during dormancy.

Despite these variations, some general principles apply. Do not apply zinc phosphide-treated bait to growing crops unless label specifically allows it. Do not graze animals in treated areas. Research has shown that hand baiting with zinc phosphide treated



baits can achieve 64% control and that an applicator could treat one acre per hour.

Because of the damage caused by Columbian ground squirrels to Montanan producers, the Montana Department of Agriculture has issued a Special Local Needs (SLN also known as 24c) registration in the past. Unfortunately, at the present time, no SLNs are available for zinc phosphide-based products.

Read the weather forecast before applying any zinc phosphide-treated bait. Zinc phosphide degrades in moist conditions. Do not apply bait if rain is expected in 48 hours, unless protected by a bait station if bait stations are allowed by the label at that site.

#### **Tips for Effective Hand baiting**

- 1) Use calibrated dippers or spoons for applying bait and designate them for pesticide use only. Apply bait only at the label recommended amount.
- 2) Proper placement of bait is critical for successful control. Do not pile bait because this is not a natural food placement for squirrels and piles of grain attract livestock and non-target wildlife. The amount of bait specified on the label should be scattered, not piled, adjacent to each active burrow. Do not place bait directly in front of the burrow entrance. Place bait slightly to the side so that ground squirrels won't bury or trample bait as they clean burrows or move in and out of their burrows. Do not place bait inside burrows unless label requires it. Squirrels are more accustomed to foraging above ground for their food and less likely to accept bait found in the burrow. Bait all active burrows. Incomplete coverage of a squirrel colony will result in poor control.
- 3) Remove livestock from treatment areas even if not required by the label. In addition to reducing risk to livestock, ground squirrel control will improve as livestock will not be trampling bait placements.
- 4) In areas known to be frequented by waterfowl or other seed-eating birds, consider additional precautions such as patrolling the area or using scare devices after bait application. Consider use of alternative methods such as burrow fumigants or bait stations in high-risk areas.

When using bitter tasting rodenticides such as zinc phosphide, pre-baiting helps to increase acceptance by conditioning the squirrels to eat the grain quickly without tasting it first. One study showed that pre-baiting improved acceptance, and therefore, control by 100%. The disadvantages of pre-baiting include

increased cost and labor. For large acreages, use of mechanical spreaders to distribute pre-bait will save time and therefore may be less expensive than pre-baiting by hand, if the label does not mandate pre-baiting by hand. Keep in mind that zinc phosphide should only be applied once a year. The reasoning is straightforward. Squirrels that survived their initial encounter with zinc phosphide will remember the taste and the resulting sickness. Therefore, it is unlikely that they will consume it a second time while their memory is still fresh. For this reason, it is important to time the application when bait acceptance tests show good bait acceptance.

Several suggestions follow to help optimize control efforts when using zinc phosphide-treated baits.

#### **1. Be Sure The Entire Population Is Active**

Bait when the entire population is active and feeding. If a portion of the population is in hibernation, it does little good to apply baits. Baiting should never be done at the first sign of activity in the spring or when the squirrels start to hibernate late in the summer. Baiting is not recommended late in the gestation period and shortly after the young are born when females may be relatively inactive above ground. This period varies locally but it generally begins four to eight weeks after emergence from hibernation. The activity of females can be checked by shooting or trapping a number of squirrels (10 to 20) and checking the ratio of males to females. If the sample is 50 percent or greater in favor of females, baiting is appropriate if other factors are satisfied. If the sampled females are nursing young or are in late pregnancy, postpone baiting until the young are active above ground. At first emergence from the burrow, young are easily distinguished from adults by size. Once young are seen foraging away from the burrow entrances, baiting can be conducted provided they were feeding on the pre-bait.

#### **2. Be Sure That Ground Squirrels Are Readily Accepting Grain**

Columbian ground squirrel feeding habits vary with the time of year (Figure 8). To determine if they will accept bait, scatter a teaspoon of nontoxic whole oats in a 6-inch spot by 25 or more burrows in the treatment area. Each test spot should be separated by 25 or more feet and marked so they can be revisited. Check the pre-bait the next day or two to determine if the grain was consumed. Delay baiting until untreated grain is readily accepted. Evidence that ground squirrels are not eating the pre-bait indicates

that the use of toxic bait is not appropriate at that time. Note that bait acceptance in early spring is generally poor. The squirrels' preference for succulent forage and the lack of natural seed production at this time of year usually results in poor bait acceptance. Researchers found that zinc phosphide efficacy achieved only 48 percent in May

compared to 71 percent in July. This is unfortunate because early control would be desirable to prevent spring crop damage and reduce the number of squirrels born that year. Early spring baiting is sometimes successful but should not be conducted without assuring bait will be accepted.

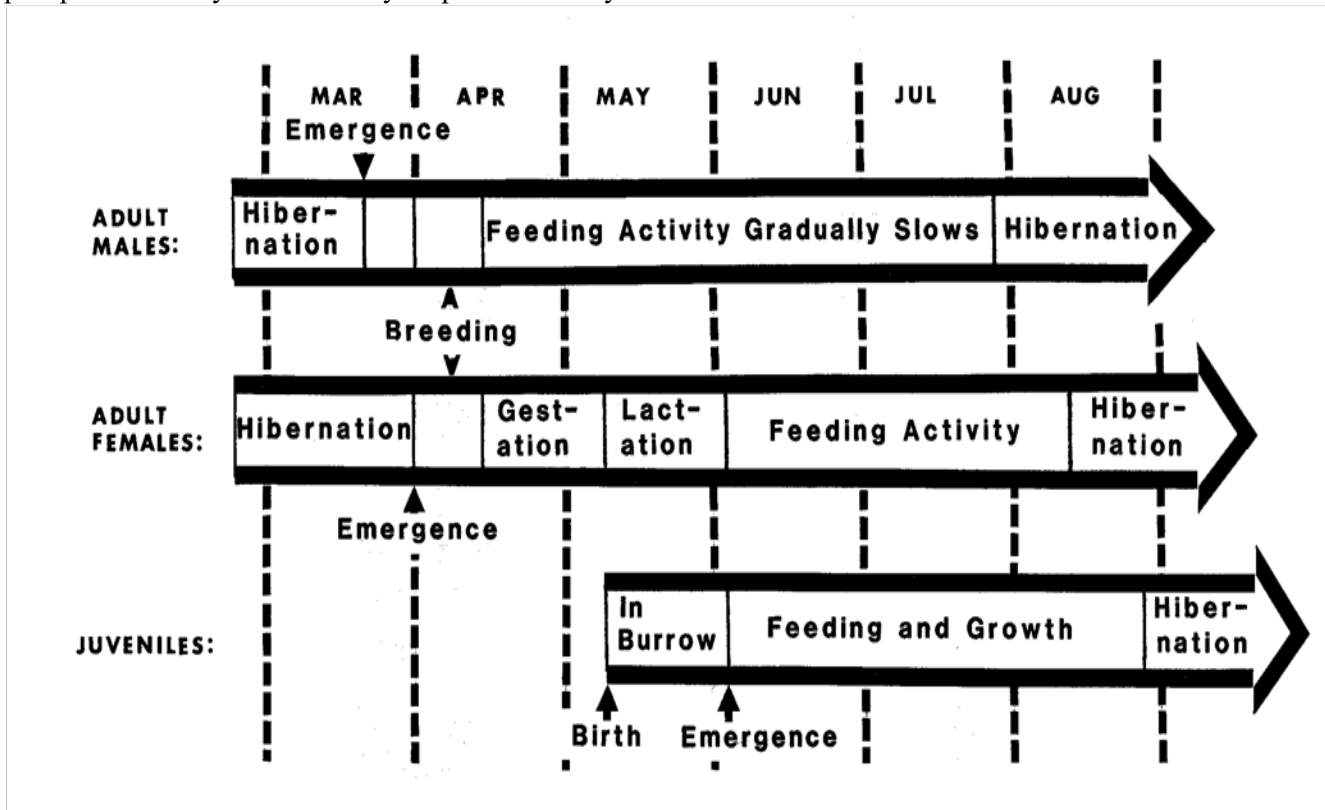

Figure 8. Life cycle of a Columbian ground squirrel. The dates above are approximations and may vary depending on elevation and weather conditions for a particular year.

**Bottom line:** The question of when to bait Columbian ground squirrels is very complex and there are presently no "hard and fast" answers. Each applicator must determine precise timing for his/her own area by observing ground squirrel activity and testing bait acceptance by the method described above.

Montana has one anticoagulant registered for control of Columbian ground squirrels, namely Rozol®. Anticoagulants are chemicals that inhibit the blood's ability to clot. Animals receiving a lethal dose, die from internal hemorrhaging and external cuts that continue to bleed. Since ground squirrels must feed multiple times to obtain a lethal dose, it is essential that a continuous supply of toxicant is available. Always read and follow the label. Keep in mind that neither product is labeled for the control of ground squirrels on residential lawns.

Ramik® Green, active ingredient diphacinone, (Neogen Ramik Green EPA# 61282-46; MT SLN# 10-0002) is a general use product whose SLN is presently in discontinued status. This means that dealers may only sell supplies with SLN labels that are already in possession as of October 30, 2019 and they must sell those supplies by October 30, 2024. If you have purchased the product with an accompanying SLN label, you have till October 30, 2024 to use your stock. The product may only be used inside tamper-resistant bait stations.

Rozol®, active ingredient, chlorophacinone, (Liphatech; 7173-184; MT SLN #00-0007)

Rozol's product is a restricted use pesticide. It may be used in non-residential areas, such as golf courses, pastures, rangeland, alfalfa, wheat, and crop areas. It may be applied by hand or with bait stations. Rozol does require applicators to apply pre-bait to confirm

that the ground squirrels will feed on the toxic bait. As with all SLN labels, applicators must have the primary label AND the special local needs label on hand when using the pesticide.

Because anticoagulants require ground squirrels to feed on the bait several times to obtain a lethal dose, applicators must carefully follow the application regimen stated on the label. Failure to ensure that ground squirrels have access to the bait for the required number of feedings will result in poor control. Generally, stations should be checked every couple of days in the early phases of control. Once a general sense for how much bait is consumed is obtained, applicators can adjust their visits according to the level of consumption and the requirements of the label.

At the present time, no bait is labelled for the control of Columbian ground squirrels on residential lawns.

## **General Principles for Using Toxic Baits**

### **1. Use Quality Bait**

When toxic baits are applied, they must compete with the other food items on which the squirrels are foraging. Use fresh bait, whenever possible. Fresh bait must not be excessively dry, decayed, or contaminated by other chemicals or odors, and thus will be the most palatable. Note that the potency of the bait does not degrade. If bait must be carried over to the following year, store separately in a weatherized, mouse-proof area to prevent contamination from other chemicals, moisture or mice, and in a cool to moderate temperature to reduce dehydration.

### **2. Treat Buffer Zones**

Columbian ground squirrels are capable of moving considerable distances. Some individuals may disperse over a mile from their birth area but most move less than 350 yards. This fact must be considered when conducting a control program. A treated area cleared of squirrels may be invaded almost immediately by squirrels from adjacent areas. Within a short time, it may appear that no treatment occurred on the treated area. The result may be that the squirrel population on the treated area may return to pretreatment levels by the following year.

Reinvasion can be reduced by treating a buffer zone 350 yards wide around the area to be protected. Particular attention should be paid to areas bordering roads as they serve as pathways for ground squirrel migration. If good control is obtained on both the

crop area and the buffer zone, retreatment should not be necessary for at least one year. In some cases, protection of the crop area may last 2 or 3 years before retreatment is necessary. Treating a buffer zone is initially costlier but it is less expensive over the long term because of increased crop protection.

### **3. Bait Stations**

A bait station is a container that protects bait from weather damage and hinders access by non-target animals and children, while allowing access by the squirrels. Bait stations may only be used when the rodenticide label explicitly allows use. Applicators choosing to use zinc-phosphide-based products that permit use of bait stations must abide by any pounds/acre restrictions and site restrictions. Applicators must also understand that, unlike Rozol Ground Squirrel Oat Bait, stations with ZP may only be filled once per season.

Bait stations can be homemade (Figure 9) or professionally manufactured (Figure 10). The key is that stations must be constructed to fill the following functions. First, they must prevent children, domestic animals, and non-target wildlife from accessing the bait. This means that the stations should be durable enough to withstand kicking or gnawing and anchored to prevent a child from shaking out the bait. Second, the opening should be only as large (3 inches without end cap, 4 inches with end cap) as necessary to ensure that ground squirrels can access the bait. Third, they must be constructed to prevent bait from spilling out of the openings. When using PVC pipe stations, simply cut an end-cap in half and secure to the end of each pipe. Adding an elbow to the station (see Figure 9) reduces spillage also by redirecting the gravitational force on the bait in the vertical arm. For more information on building and using bait stations download our bulletin on bait stations at <https://agr.mt.gov/Vertebrate-Pests>.

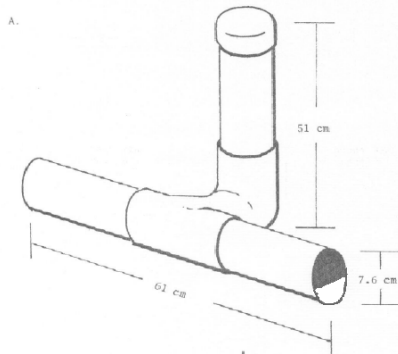

Figure 9. PVC pipe bait station use 4-inch pipe with cut end cap to reduce spillage of bait.



Figure 10. Wilco bait station for ground squirrels.

Bait stations using anticoagulant baits must be maintained regularly to replenish bait and remove spoiled bait. Place stations in sufficient density, without violating any pound/acre restrictions, so all squirrels have an opportunity to feed on the bait. Maintain bait stations for at least 30 days because research shows that ground squirrels may take 10 days to enter. Although the initial cost of obtaining and placing the stations is high for large acreages, the benefits of the stations may be cost effective when evaluated over several years. In 2018, researchers found that bait stations using Rozol reduced ground squirrel presence by 90%.

### Pesticide Safety

Safety is essential when using pesticides including toxic baits. Toxic baits present two types of hazards to non-target animals. Primary poisoning occurs when a non-target animal consumes the toxicant directly. Secondary poisoning occurs when a predator or scavenger feeds on the carcasses of poisoned animals.

Non-target animals most at risk from primary poisoning are domestic livestock, poultry and certain seed-eating wildlife species, including waterfowl, grouse and some songbirds. Reduce the risk of primary

poisoning by carefully following pesticide label directions and by implementing safety practices such as those listed below:

- 1) Keep baits in original labeled containers and store in locked, weather tight, rodent proof storage when not in use. During application, keep excess bait in locked or latched storage to prevent access by livestock or children.

- 2) Apply only the amount recommended on the label. Scatter the bait near each active burrow. Do not pile bait as this increases its attractiveness to livestock and non-target wildlife and it is not a natural food placement for squirrels.

- 3) Remove livestock from treatment areas. In addition to reducing risk to livestock, ground squirrel control will improve if livestock are not trampling on bait placements. It is neighborly to notify neighbors of your bait applications. Suggest confinement of animals capable of entering the treatment area, such as dogs, cats, until applied bait is consumed, or the label's exclusion period has passed, whichever is longer.

- 4) Implement, whenever possible, additional precautions such as patrolling the area or using scare devices after bait application in areas known to be frequented by waterfowl or other seed eating birds. Consider the use of alternative methods, such as burrow fumigants or bait stations in areas where risk to non-target species is high.

- 5) Pick up and dispose spilled bait as label instructs.

- 6) Secondary hazard from rodenticide baits results from the presence of quantities of residual poison in ground squirrel carcasses. With anticoagulant rodenticides, residual poison in the carcass can be hazardous in various degrees to predatory and scavenging birds and animals, such as wild or domestic felines and canines. Burial of ground squirrel carcasses helps reduce the hazards to potential non-target animals.

Secondary hazard from zinc phosphide is considered low as zinc phosphide converts to phosphine gas in the stomach. The phosphine gas dissipates from the carcass quickly after death leaving little residue to cause secondary poisoning.

### Disease

Though rare, plague (*Yersenia pestis*), and the fleas associated with transmitting the disease, have been found in Columbian ground squirrels.

Outbreaks of plague can occur without warning; however, the risk is greater in areas where plague has occurred in the past. Individuals involved in the control of Columbian ground squirrels should wear insect repellent with the active ingredient DEET and always wear gloves when handling ground squirrels or working near their dens. Fleas can jump 4 inches; one only be in close proximity to be at risk (Figure 11).



Figure 11. A flea after its blood meal.

Individuals should monitor their health for at least one week as the symptoms of plague usually begin within six days of exposure. If flu-like symptoms occur, inform medical professionals that you have been working around ground squirrels. Readers should be aware that free-ranging pets, such as cats, can transport fleas back to residences, and thereby provide another potential avenue for exposure.

#### **DEPARTMENT SERVICES**

As with most programs, rodent control will be most effective when all affected landowners work together. The Montana Department of Agriculture vertebrate pest specialist program will work with county commissioners, extension agents and landowners to establish a program suited to local and county needs. Outreach, trainings and field demonstrations are provided to inform landowners how, when and where to control Columbian ground squirrels and other field rodent pests. Interested individuals should contact the Montana Department of Agriculture.

In Lewistown:

Stephen M. Vantassel, Vertebrate Pest Specialist  
Phone (406) 538-3004 [svantassel@mt.gov](mailto:svantassel@mt.gov)

Additional printed information on the control of ground squirrels and other vertebrates is available from the Montana Department of Agriculture website <https://agr.mt.gov/Vertebrate-Pests>

**MONTANA POISON CONTROL**  
**(Emergencies)**  
**1-800-222-1222**

**MONTANA DEPARTMENT of PUBLIC**  
**HEALTH & HUMAN SERVICES**  
**Public Health & Safety**  
**1-406-444-4141**  
<https://dphhs.mt.gov/>

Disclaimer: Reference to commercial products or trade names is made with the understanding that no discrimination is intended of those not mentioned and no endorsement by the Montana Department of Agriculture is implied for those mentioned.

#### **Credits**

Cover. Jim Stevens

Fig. 1. Anne Elliott

Fig. 2. Montana Field Guide

<http://fieldguide.mt.gov/>

Fig. 3. Montana Department of Agriculture?

Fig. 4. Jasmine Reimer, Montana Department of Agriculture

Figs. 5-7. Stephen M. Vantassel/Montana Department of Agriculture

Fig. 8. Montana Department of Agriculture?

Fig. 9. Montana Department of Agriculture?

Fig. 10. Stephen M. Vantassel/Montana Department of Agriculture

Fig. 11. Centers for Disease Control, <http://cdc.gov>