

WELCOME

CERN Courier – digital edition

Welcome to the digital edition of the January/February 2023 issue of *CERN Courier*.

The ATLAS and CMS detectors are being prepared for their biggest overhauls yet, in preparation for the tenfold increase in data to be delivered by the High-Luminosity LHC from 2029. The “Phase II” detector upgrades include state-of-the-art all-silicon inner trackers, high-granularity calorimeters and faster trigger and data-acquisition systems (p22 and 33). ALICE and LHCb are also preparing major upgrades for the 2030s. Meanwhile, the LHC keeps on breaking records, producing a peak proton–proton luminosity of $2.5 \times 10^{34} \text{ cm}^{-2} \text{ s}^{-1}$ and providing lead–lead collisions at 5.36 TeV per nucleon pair (p11) before CERN’s year-end-technical stop on 28 November.

This issue looks back to the discovery of the W and Z bosons at the SPS 40 years ago (p41) and to the origins of the SESAME light source in the CERN theory corridors 30 years ago (p28). We also showcase new applications of accelerator technology in radiotherapy (p8) and future hydrogen-powered aircraft (p9), and report on the most precise tests of lepton-flavour universality from LHCb (p7). Also in the issue: Effective Field Theory (p37), sphere-stacking (p42), the latest conference reports (p15) and LHC-experiment results (p12), reviews (p44), careers (p46) and more.

To sign up to the new-issue alert, please visit:
<http://comms.iop.org/k/iop/cerncourier>

To subscribe to the magazine, please visit:
<https://cerncourier.com/p/about-cern-courier>

EDITOR: MATTHEW CHALMERS, CERN
DIGITAL EDITION CREATED BY IOP PUBLISHING



ATLAS AND CMS PREPARE FOR HL-LHC

Fresh perspective on the flavour anomalies
All things Effective Field Theory
SESAME’s 30-year journey in science diplomacy



Sci-Compiler (Scientific Firmware Compiler)

A unique graphical software tool to program the Open FPGA of CAEN boards

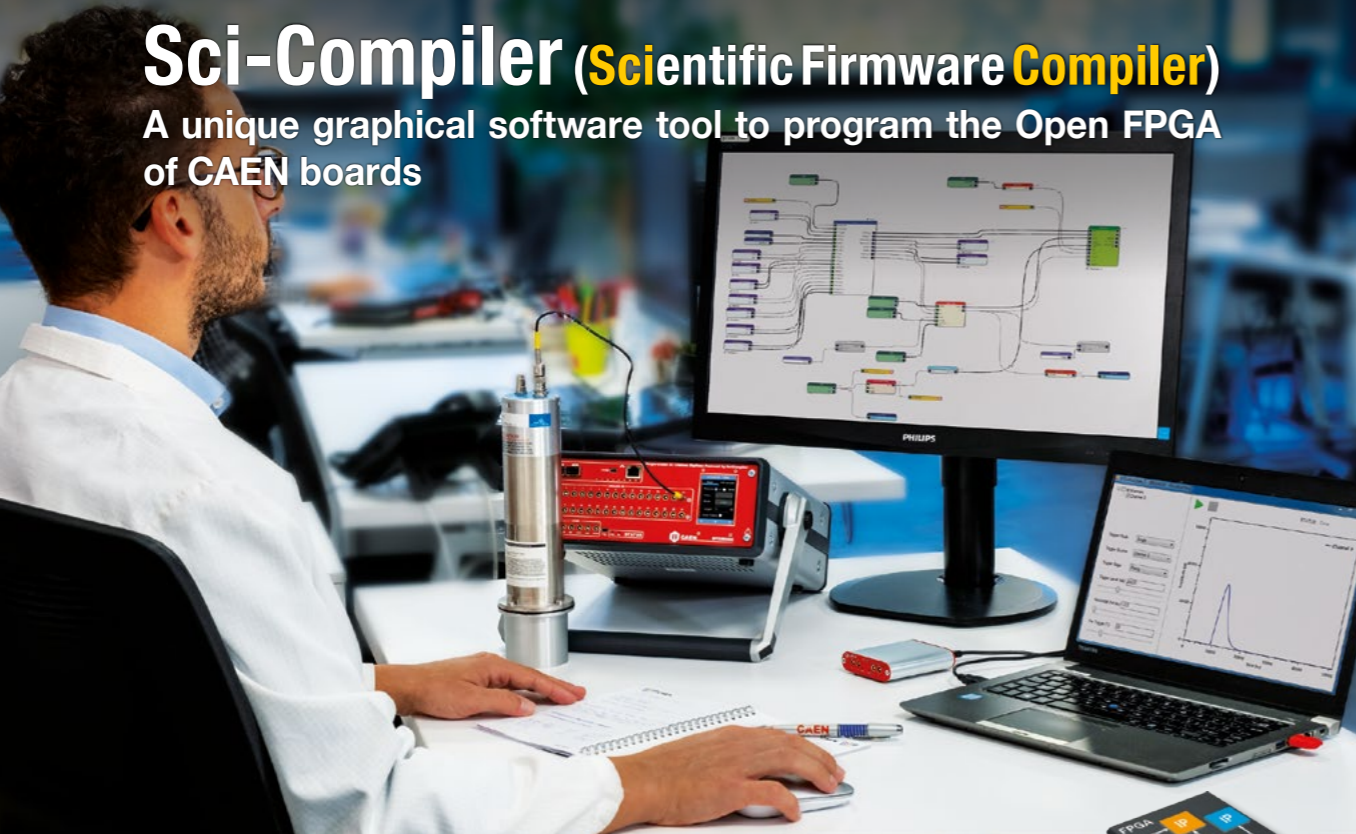

Just Drag&Drop Virtual Instruments and Wires!

The Sci-Compiler is an innovative approach to modern readout system development. With an **intuitive user interface based on block diagrams**, it tremendously accelerates the generation of custom firmwares and related software libraries. **A new approach, even for non-expert FPGA users!** More than 100 built-in blocks are available to implement a wide variety of Nuclear Physics applications.

Sci-Compiler supports the following Open FPGA CAEN boards:

- DT2740 - VX2740 - V2740 64 Ch. 16-bit 125 MS/s Digitizer single-ended or differential inputs
- DT2745 - VX2745 - V2745 64 Ch. 16-bit 125MS/s Digitizer with Programmable Input Gain
- R5560 128 Ch. 14-bit @125 MS/s Digitizer with differential inputs
- R5560SE 128 Ch. 14-bit @125 MS/s Digitizer with single-ended inputs
- DT5560SE 32 Ch. 14-bit @125 MS/s Digitizer with single-ended inputs
- DT5495 - V2495 Programmable Logic Units
- DT5550 Programmable 32-channel Sequencer and Readout System (User Programmable FPGA)
- DT5550W Weeroc ASICs DAQ Development system
- Sci-Compiler SMART Kit / SP5650 Open FPGA Kit (DT1260)

DT: Desktop / VX: VME64X / V: VME64 / R: Rack

WANT TO START?



Evaluate the Sci-Compiler software with the **Sci-Compiler Smart Kit!**



Do you need to teach FPGA programming? Have a look at the **SP5650 Open FPGA Kit**



www.caen.it
Small details... Great differences



Linear radiotherapy A novel proton-linac system is preparing to treat its first patients. **8**

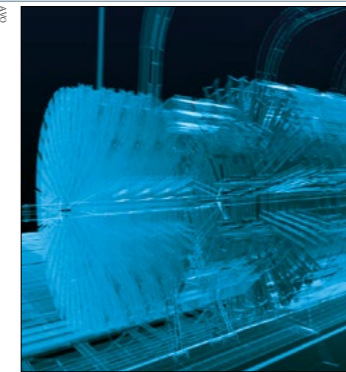

Polarising Unlocking the physics potential of the proposed FCC-ee. **19**



Sphere-packing Fields medallist Maryna Viazovska describes the power of pure mathematics. **42**

NEWS

ANALYSIS

LHCb probes LFU
• Debut for proton linac
• Joining forces for FLASH • CERN, Airbus aim high • IRIS project ramps up • Neutrino astronomy. **7**

ENERGY FRONTIERS

Hunting dark matter with invisible Higgs decays • Higgs flavour-symmetry tests • Novel method to determine γ • Quark-gluon plasma's hidden charm. **12**

FIELD NOTES

Physics Beyond Colliders
• Combining quantum with HEP • Future detector magnets • The power of polarisation • Keeping research safe • EURO-LABS simplifies access. **15**

PEOPLE

CAREERS

Moving from big science into big tech
CERN alumni working in big-tech firms offer practical advice when seeking to move out of academia. **46**

OBITUARIES

Marie-Noëlle Minard
• Donald Hill Perkins
• Sylvie Rosier-Lees
• Valery Rubakov
• Volker Soergel. **51**

FEATURES

ATLAS

A new ATLAS for the high-luminosity era
The major 'Phase II' upgrades taking place to prepare the ATLAS detector for the High-Luminosity LHC. **22**

SESAME

From dreams to beams
Eliezer Rabinovici describes a 30 year-long journey in science diplomacy. **28**

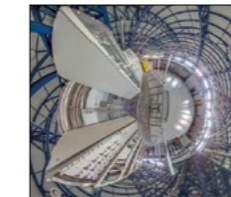

CMS

CMS prepares for Phase II
An optimised detector with enhanced granularity will extract maximal physics from the LHC from 2029. **33**

EFT

A theory of theories
Effective field theory is now seen as the most fundamental and generic way to capture the physics of nature at all scales. **37**

OPINION

VIEWPOINT

Remembering the W discovery
Luigi Di Lella recalls the events leading to the discovery of the W and Z bosons 40 years ago. **41**

INTERVIEW

Playing in the sandbox of geometry
Maryna Viazovska talks about her research in fundamental mathematics and its many applications. **42**

REVIEWS

A clear guide for accelerator physicists
Special Topics in Accelerator Physics
• Frank Wilczek: 50 Years of Theoretical Physics. **44**

DEPARTMENTS



On the cover Improved resistive-plate-chamber technology being installed in CMS in 2021. **33**

FROM THE EDITOR	5
NEWS DIGEST	11
APPOINTMENTS & AWARDS	48
RECRUITMENT	49
BACKGROUND	54



SHR

ULTRA PRECISE HIGH VOLTAGE SOURCE + MEASURE UNIT

AVAILABLE AT CERN ELECTRONIC-POOL



W-IE-NE-R + ISEG
SUPPORT OFFICE AT CERN
Dr. Dipl.-Phys. Erich Schaefer
Bat.: 13/R-023 | +41 75411 4301 | e.schaefer@iseg-hv.de

PERFECT FOR
USE WITH NHR:
QUALITY NIM CRATES

ALSO AVAILABLE
AS NIM-DEVICE:
NHR



- ▶ 2 / 4 channels, 2 kV / 6 kV versions
- ▶ Electronically switchable polarity
- ▶ 6 kV channel with electronically switchable modes: up to 2 kV/4 mA, 4 kV/3 mA or 6 kV/2 mA
- ▶ High-precision / very low ripple and noise / high resolution
- ▶ USB / Ethernet* interface
- ▶ Integrated **iCS25** (ARM Linux server hardware) with onboard python scripting*
- ▶ 4.3" TFT capacitive touch display (SHR)

*SHR-device only



WWW.ISEG-HV.COM/SHR

FROM THE EDITOR

From detector upgrades to anomaly downgrades



Matthew Chalmers
Editor

Three decades since the ATLAS and CMS collaborations submitted letters of intent for the construction of their detectors, these marvels of technology and engineering are being prepared for their biggest overhauls yet. The tenfold increase in data to be delivered by the High-Luminosity LHC from 2029 onwards promises sub-percent precision on many Standard Model measurements – but only if the detectors can fully exploit the more complex and higher-rate collisions. Involving thousands of physicists and engineers from many tens of countries, and mostly due to be installed during Long Shutdown 3 in 2026–2029, many of the “Phase II” upgrades push detector technologies to new heights.

For ATLAS, they include a state-of-the-art all-silicon inner tracker, a new high-granularity timing detector, new and upgraded forward and luminosity detectors, improved muon coverage, faster trigger and data-acquisition systems, and new calorimeter readout electronics (p22). In CMS, the tracker and the calorimeter endcaps will be replaced with innovative new systems, a new minimum-ionising-particle timing detector and luminosity detector will be installed, almost all of the electronics will be replaced, and additional muon forward stations will be mounted (p33). ALICE and LHCb are also preparing major upgrades for the 2030s, which will be explored in upcoming issues. In the meantime, the LHC keeps on breaking records: the period leading up to CERN’s year-end-technical stop on 28 November saw the peak proton-proton luminosity reach $2.5 \times 34 \text{ cm}^{-2} \text{ s}^{-1}$ and test collisions between lead nuclei take place at 5.36 TeV per nucleon pair (p11).

This issue also takes a look back – to the discovery of the W and Z bosons at the SpP5 40 years ago (p41) and to the origins of the SESAME light source in the CERN theory corridors 30 years ago (p28) – and showcases applications of accelerator science. UK-based firm Advanced Oncology, using a novel proton linac system, is preparing to treat its first patients (p8). French firm THERYQ has joined a collaboration between CERN and Lausanne University Hospital to develop FLASH radiotherapy using electrons (p8). And CERN has teamed up with Airbus to explore superconducting technologies for future hydrogen-powered aircraft (p9).

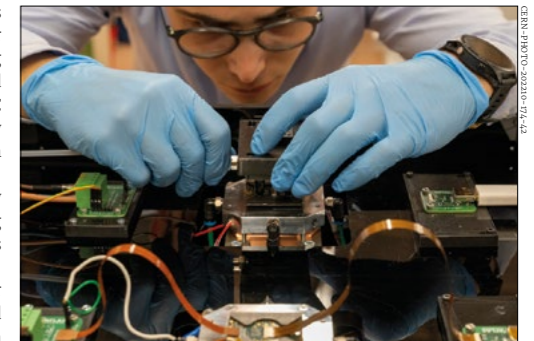

Granular R&D for the ATLAS Phase II inner tracker in October 2022.

Reality check

The new year brings fresh perspective on the flavour anomalies. New comparisons between the rates of rare B-meson decays to muons and to electrons announced by LHCb in December (p7) agree with the Standard Model, and differ from previous LHCb results that had hinted at a violation of lepton-flavour universality (LFU). This magazine has followed the flavour anomalies closely, from their emergence almost a decade ago, to their appearance in different channels, the fascinating new physics that might be behind them, and the 3.1 σ evidence reported by LHCb in 2021. Forming a consistent pattern, and with no *a priori* reason to expect such departures from theory, the anomalies generated cautious excitement in the field.

A more comprehensive LHCb analysis, undertaken in parallel and un-blinded in June, shows that the previous LHCb “R(K)” analysis had underestimated a systematic uncertainty concerning the identification of hadronic backgrounds to electrons. The fading of this most theoretically clean probe of LFU will no doubt cast the remaining flavour anomalies in a more sober light, but who can be disappointed with the rigour of the scientific method? The millennia-long quest to understand nature’s fundamental workings continues.

This issue also showcases applications of accelerator science

Reporting on international high-energy physics

CERN Courier is distributed to governments, institutes and laboratories affiliated with CERN, and to individual subscribers. It is published six times per year. The views expressed are not necessarily those of the CERN management.

Editor
Matthew Chalmers
Associate editor
Kristiane Bernhard-Novotny
Astrowatch contributor
Arshia Ruina
Archive contributor
Peggie Rimmer

E-mail
cern.courier@cern.ch

Advisory board
Peter Jenni, Christine Sutton, Claude Amsler, Philippe Bloch, Roger Forty, Mike Lamont, Joachim Kopp

Laboratory correspondents
Argonne National Laboratory
Tom LeCompte
Brookhaven National Laboratory
Achim Franz
Cornell University
D G Cassel
DESY Laboratory
Till Mundt
Fermilab
Kurt Riesselmann
Forschungszentrum Jülich
Markus Buescher
GSI Darmstadt
I Peter IHEP, Beijing
Lijun Guo
INFN
Antonella Varaschin
Jefferson Laboratory
Kandice Carter

Lawrence Berkeley Laboratory
Spencer Klein
Los Alamos National Lab
Rajan Gupta
NCSL
Ken Kingery
Nikhef
Robert Fleischer
Orsay Laboratory
Anne-Marie Lutz
PSI Laboratory
P-R Kettle
Saclay Laboratory
Elisabeth Locci
UK STFC
Stephanie Hills
SLAC National Accelerator Laboratory
Melinda Lee
SNOLAB
Samantha Kuula
TRIUMF Laboratory
Marcello Pavan

Produced for CERN by IOP Publishing Ltd
No.2 The Distillery, Glassfields, Avon Street Bristol BS2 0GR
Tel +44 (0)117 929 7481

Head of Media Jo Allen
Head of Media Business Development
Ed Jost
Content and production manager Ruth Leopold
Technical illustrator
Alison Tovey
Advertising sales
Curtis Zimmermann
Recruitment sales
Chris Thomas

Advertisement production Katie Graham
Marketing and circulation Laura Gillham, Alison Gardiner

Advertising
Tel +44 (0)117 930 1026 (for UK/Europe display advertising) or +44 (0)117 930 1164 (for recruitment advertising); e-mail sales@cerncourier.com

General distribution
Courier Addressage, CERN, 1211 Geneva 23, Switzerland; e-mail courier-addressage@cern.ch

Published by CERN, 1211 Geneva 23, Switzerland
Tel +41 (0) 22 767 61 11

Printed by Warners (Midlands) plc, Bourne, Lincolnshire, UK

© 2023 CERN
ISSN 0304-288X



NEWS ANALYSIS

FLAVOUR PHYSICS

LHCb brings leptons into line

On 20 December, the LHCb collaboration presented new measurements of rare B-meson decays that provide a high-precision test of lepton flavour universality, a key feature of the Standard Model (SM). Previous studies of these decays had hinted at intriguing tensions with predictions, but the improved and wider-reaching analysis of the full LHCb dataset is fully in line with the SM.

A central mystery of particle physics is why the 12 elementary quarks and leptons are arranged in pairs across three generations, identical in all but mass. Lepton flavour universality (LFU) states that the SM gauge bosons are indifferent to which generation a charged lepton belongs, implying that certain decays of hadrons involving leptons from different generations should occur at the same rates. In recent years, however, an accumulation of results has suggested a possible violation of LFU in B-meson decays involving fundamental b- to s-quark transitions, such as the decay of a B into a K meson. Such processes are highly suppressed in the SM because they proceed through higher-order diagrams, making them promising channels in which to detect the possible influence of new particles.

A powerful test of LFU is to measure the relative rates of the processes $B \rightarrow K\mu^+\mu^-$ and $B \rightarrow Ke^+e^-$, a quantity called $R(K)$, and the equivalent ratio for decays involving an excited kaon, $R(K^*)$. The SM predicts such ratios to be equal to unity once differences in the lepton masses are accounted for. In 2021, based on data collected during LHC Run 1 and Run 2, LHCb found $R(K)$ to lie 3.1σ below the SM prediction (CERN Courier May/June 2021 p17). For $R(K^*)$, measurements in 2017 based on Run 1 data were consistent with the SM at the level of $2-2.5\sigma$.

The latest LHCb analysis simultaneously measures $R(K)$ and $R(K^*)$ using the full Run 1 and Run 2 datasets. A sequence of multivariate selections and strict particle-identification requirements produced a higher signal purity and a better statistical sensitivity than the previous analysis. The two ratios were also computed in two bins of the squared di-lepton

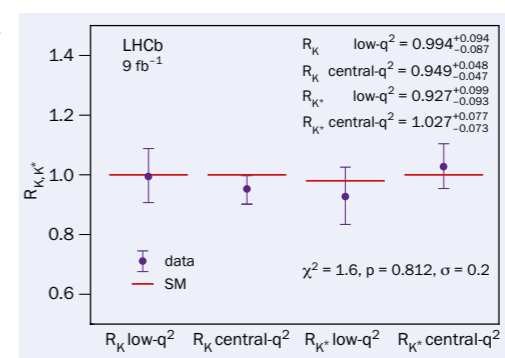

Flatline Final measured values of lepton flavour universality observables in $B \rightarrow K\mu^+\mu^-$ and $B \rightarrow Ke^+e^-$ decays with the full Run 1 and 2 data sample, and their overall compatibility with the Standard Model.

Earlier LHCb indications of anomalies with lepton flavour universality triggered immense excitement

momentum-transfer q^2 , thereby producing four independent measurements. The measured values of $R(K)$ and $R(K^*)$ are now compatible with the SM at the level of 1σ and supersede previous LHCb publications on these topics. The new value of $R(K)$ is based on an integrated luminosity three times larger than that used in 2017, and the two results are in broad agreement. For $R(K)$ in the central q^2 region, on the other hand, the new value is significantly higher than the 2021 result.

“Although a component of this shift can be attributed to statistical effects, it is understood that this change is primarily due to systematic effects,” explains LHCb spokesperson Chris Parkes of the University of Manchester. “The systematic shift in $R(K)$ in the central q^2 region compared to the 2021 result stems from an improved understanding of misidentified hadronic backgrounds to electrons, due to an underestimation of such backgrounds and the description of the distribution of these components

in the fit. New datasets will allow us to further research this interesting topic, along with other key measurements relevant to the flavour anomalies.”

The search goes on

The flavour anomalies are a set of discrepancies observed over the past several years in processes involving b \rightarrow s and b \rightarrow c quark transitions. Among the former is the parameter P'_s based on angular distributions of the decay products of B-meson decays. Although these remain unaffected by the new LHCb result, tests of LFU via $R(K)$ -type measurements are theoretically cleaner. On 18 October, complementing previous results by Belle, BaBar and LHCb, the LHCb collaboration made the first simultaneous measurement at a hadron collider of $R(D) = BR(B \rightarrow D\tau\nu)/BR(B \rightarrow D\mu\nu)$ and its counterpart $R(D^*)$, which probe b \rightarrow c quark transitions. Based on Run 1 data, the new values of $R(D)$ and $R(D^*)$ are compatible both with the current world average and with the SM prediction at 2.2σ and 2.3σ , respectively.

“Earlier LHCb indications of anomalies with lepton flavour universality triggered immense excitement, not least because possible new-physics explanations resonated with other hints of deviations from the SM,” says CERN theorist Michelangelo Mangano. “That such anomalies could have been real shows how little we know about the deep origin of flavour symmetries and their relation with the Higgs, and highlights the key role of experimental guidance. Theoretical efforts to interpret the anomalies explored novel avenues, exposing a myriad of unanticipated phenomena possibly emerging at distances shorter than those so far described by the SM. The latest LHCb findings take nothing away from our mission to push further the boundary of our knowledge, and the search for anomalies goes on!”

Further reading

LHC Collab. 2022 LHCb-PAPER-2022-045 (submitted to *Phys. Rev. Lett.*).
LHC Collab. 2022 LHCb-PAPER-2022-046 (submitted to *Phys. Rev. D*).

IPAC₂₃

14th International Particle Accelerator Conference

IPAC '23

7 - 12 May 2023
Venice, Italy



Early-Bird Delegate registration
deadline February 27, 2023

Full Delegate Registration
deadline May 7, 2023

Hosting institutions



Supported by



browse for more info
ipac23.org



NEWS ANALYSIS

NEWS ANALYSIS

MEDICAL APPLICATIONS

Radiotherapy debut for proton linac

Hadron therapy, to which particle and accelerator physicists have contributed significantly during the past decades, has treated more than 300,000 patients to date. As collaborations and projects have grown over time, new methods aimed at improving and democratising this type of cancer treatment have emerged. Among them, therapy with proton beams from circular accelerators stands out as a particularly effective treatment: protons can obliterate tumours, sparing the surrounding healthy tissues at higher rates than conventional electron or photon therapy. Unfortunately, present proton- and ion-therapy centres are large and very demanding on the design of buildings, accelerators and gantry systems.

A novel proton accelerator for cancer treatment based on CERN technology is preparing to receive its first patients in the UK. Advanced Oncotherapy (AVO), based in London, has developed a proton-therapy system called LIGHT (Linac Image-Guided Hadron Technology) – the result of more than 20 years of work at CERN and spin-off company ADAM, founded in 2007 to build and test linacs for medical purposes and now AVO's Geneva-based subsidiary. LIGHT provides a proton beam that allows the delivery of ultra-high dose rates to deep-seated tumours. The initial acceleration to 5 MeV is based on radio-frequency



Compact treatment
The LIGHT accelerator at STFC Daresbury Laboratory, UK.

quadrupole (RFQ) technology developed at CERN and supported by CERN's knowledge transfer group. LIGHT reached the maximum treatment energy of 230 MeV at the STFC Daresbury site on 26 September. Four years after the first 16 m-long prototype was built and tested at LHC Point 2, this novel oncological linac will treat its first patients in collaboration with University Hospital Birmingham at Daresbury during the second half of 2023, marking the first time a proton linear accelerator is used for cancer therapy.

LIGHT operates with components and designs developed by CERN, ENEA, the TERA Foundation and ADAM. Components of note include LIGHT's RFQ, which contributes to its compact design, as well as 19 radio-frequency modules composed of four side-coupled drift-tube accelerating cavities based on a TERA

Foundation design and 15 coupled accelerating cavities with industrial design by ADAM. Each module is controlled to vary the beam energy electronically, 200 times per second, depending on the depth of the tumour layer. This obviates the need for absorbers (or degraders), which greatly reduce the throughput of protons and produce large unwanted radiation, therefore reducing the volume of shielding material required. This design allows the linear accelerator to generate an extremely focused beam of 70 to 230 MeV and to target tumours in three dimensions, by varying the depth at which the radiation dose is delivered much faster than existing circular accelerators.

"Our mission is simple: democratise proton therapy," says Nicolas Serandour, CEO of AVO. "The only way to fulfill this goal is through the development of a different particle accelerator and this is what we have achieved with the successful testing of the first-ever proton linear accelerator for medical purposes. Importantly, the excitement comes from the fact that cost reduction can be accompanied with better medical outcomes due to the quality of the LIGHT beam, particularly for cancers that still have a low prognosis. I cannot over-emphasise the importance that CERN and ADAM played in making this project a tangible reality for millions of cancer patients."

CERN, CHUV and THERYQ join forces for FLASH

In November, CERN signed an agreement with the Lausanne University Hospital (CHUV) and medical-technology firm THERYQ to develop a novel "FLASH" radiotherapy device. The device – the first of its kind and based on CERN technology – will use very high-energy electrons (VHEEs) to treat cancers that are resistant to conventional treatments, with reduced side effects. Currently, around one third of cancers are resistant to conventional radiation therapy.

VHEE FLASH technology has several advantages in addition to being capable of reaching deep-seated tumours. For example, high-energy electrons can be focused and oriented in a way that is almost impossible with X-rays, and radiotherapy devices based on electron accelerator technology will be more



Tech transfer
The CERN-CHUV-THERYQ radio-therapy facility will use accelerator technology developed for the proposed Compact Linear Collider.

compact and less expensive than current proton-based therapy devices.

FLASH radiotherapy has produced impressive results in pre-clinical animal studies at CHUV, while THERYQ, a spinoff of PMB-ALCEN, in partnership with CHUV, has been developing the technique since the beginning of 2013. CERN has responded to the challenge of producing a high dose of very-high-energy electrons in less than 100 milliseconds, as required for FLASH radiotherapy, by designing a unique accelerator based on CLIC (Compact Linear Collider) tech-

nology. The device will include a compact linear accelerator, to be manufactured by THERYQ, and use VHEE beams with energies between 100 and 200 MeV, allowing all types of cancers up to a depth of 20 cm to be treated using the FLASH technique. It is expected to be operational within two years, with the first clinical trials planned for 2025.

The new tripartite agreement between CERN, CHUV and THERYQ covers the development, planning, regulatory compliance and construction of the world's first radiotherapy device capable of treating large, deep-seated tumours using the FLASH technique. "FLASH therapy embodies the spirit of innovation that drives us in this field," explains Philippe Eckert, director general of CHUV. "Eager to offer the most effective techniques to patients, we have joined forces with a world-class research centre and a cutting-edge industrial partner to solve a medical, physical and technical problem and find innovative solutions to fight cancer."

HIGH-TEMPERATURE SUPERCONDUCTORS

CERN and Airbus collaboration aims high

On 1 December, CERN and Airbus UpNext, a wholly owned subsidiary of Airbus, launched a collaboration to explore the use of superconducting technologies in the electrical distribution systems of future hydrogen-powered aircraft. The partnership will bring together CERN's expertise in superconducting technologies for particle accelerators and Airbus UpNext's capabilities in aircraft design and manufacturing to develop a demonstrator known as SCALE (Super-Conductor for Aviation with Low Emissions).

Superconducting technologies could drastically reduce the weight of next-generation aircraft and increase their efficiency. If its expected performances and reliability objectives are achieved, the CERN-Airbus collaboration could reach the ambitious target of flying a fully integrated prototype within the next decade, says the firm. The joint initiative seeks to develop and test in laboratory conditions, an optimised generic superconductor cryogenic (~500 kW) powertrain by the



Hot stuff CERN's superconducting rare-earth barium copper oxide (also referred to as REBCO) power-transmission cable, used to study the feasibility of high-temperature superconductivity for aircraft.

end of 2025. SCALE will be designed, constructed and tested by CERN using Airbus UpNext specifications and CERN technology. It will consist of a DC link (cable and cryostat) with two current leads, and a cooling system based on gaseous helium.

"Partnering with a leading research institute like CERN, which has brought the world some of the most important findings in fundamental physics, will help to push the boundaries of research in clean aerospace as we work to make sustainable aviation a reality," said Sandra Bour-Schaeffer, CEO of Airbus UpNext. "We are already developing a superconductivity demonstrator called ASCEND (Advanced Superconducting and Cryogenic Experimental powertrain Demonstrator) to study the feasibility of this technology for electrically powered and hybrid aircraft. Combining knowledge obtained from our demonstrator and CERN's unique capabilities in the field of superconductors makes for a natural partnership."

Italy ramps up superconductor R&D

Developing high-temperature and high-magnetic-field superconducting technologies both for societal applications and next-generation particle accelerators is the goal of a new project in Italy called IRIS, launched in November and led by the INFN. IRIS (Innovative Research Infrastructure on applied Superconductivity) has received a €60 million grant from the Piano Nazionale di Ripresa e Resilienza to create a distributed R&D infrastructure throughout the country. It will focus on cables for low-loss electricity transport, and on the construction of superconducting magnets with high-temperature superconductors (HTS) in synergy with R&D for the proposed Future Circular Collider (FCC) at CERN. The project is estimated to last for 30 months, with more than 50% of the funds going to laboratories in the South of Italy.

One of the main objectives will be the construction in Salerno of a large infrastructure that will host not only a superconducting connection line, but also a centre of excellence for testing future industrial products for high-power connections, with the aim of making high-temperature superconductors less difficult and less



Future facing Participants of the IRIS kick-off meeting at the INFN headquarters in Rome on 14 and 15 November.

expensive to work with.

"With the IRIS project, Italy assumes a leading position in applied superconductivity, creating a real synergy between research institutions and universities, which will offer an important collaboration opportunity for particle physicists

and those involved in the fields of superconductivity and magnetism," explains IRIS technical coordinator Lucio Rossi of the University of Milan. "An aspect not to be overlooked is also the high educational value of the project, which will guarantee numerous doctoral and high-level training opportunities for about a 100 students, young researchers and technicians."

The activities of IRIS will be coordinated by the Laboratory of Accelerators and Applied Superconductivity (LASA) in Milan, with many partners including the universities of Genova, Milano, Naples, Salento and Salerno, and the CNR Institute for Superconductors, Innovative Materials and Devices (SPIN).

"IRIS is a virtuous example of how basic research, and in this case particle and accelerator physics, can provide an important application in other science areas, such as the development of new materials for energy saving that is essential for the creation of high-power cables without dissipation and suitable for the needs of future electricity networks serving new energy sources," says Pierluigi Campana of INFN Frascati, IRIS scientific coordinator.

Neutrinos reveal active galaxy's inner depths

Highly energetic cosmic rays reach Earth from all directions and at all times, yet it has been challenging to conclusively identify their sources. Being charged, cosmic rays are easily deflected by interstellar magnetic fields during their propagation and thereby lose any information about where they originated from. On the other hand, highly energetic photons and neutrinos remain undeflected. Observations of high-energy photons and neutrinos are therefore crucial clues towards unravelling the mystery of cosmic-ray sources and accelerators.

Four years ago, the IceCube collaboration announced the identification of the blazar TXS 0506+056 as a source of high-energy cosmic neutrinos, the first of its kind (*CERN Courier* September 2018 p7). This was one of the early examples of multi-messenger astronomy wherein a high-energy neutrino event detected by IceCube, which was coincident in direction and time with a gamma-ray flare from the blazar, prompted an investigation into this object as a potential astrophysical neutrino source.

Point source

In the following years, IceCube made a full-sky scan for point-like neutrino sources, and in 2020, the collaboration found an excess coincident with the Seyfert II galaxy, NGC1068, that was inconsistent with a background-only hypothesis. However, with a statistical significance of only 2.9σ , it was insufficient to claim a detection. In November 2022, after a more detailed analysis with a longer live-time and improved methodologies, the collaboration confirmed NGC1068 to be a point source of high-energy neutrinos at a significance of 4.2σ .

Messier 77, also known as the Squid Galaxy or NGC1068, is located 47 million light years away in the constellation Cetus and was discovered in 1780. Today, we know it to be an active galaxy: at its centre lies an active galactic nucleus (AGN), which is a luminous and compact region powered by a super massive black hole (SMBH), surrounded by an accretion disk. Specifically, it is a Seyfert II galaxy, which is an active galaxy that is viewed edge-on, with the line-of-sight passing through the accretion region that obscures the centre.

The latest search used data from the fully completed IceCube detector. Several calibrations and alignments were also



Galactic accelerator A Hubble image of the spiral galaxy Messier 77, also known as the Squid Galaxy or NGC1068, from which high-energy neutrinos have been detected by the IceCube Observatory at the South Pole.

IceCube's measurements usher in a new era of neutrino astronomy

made to the data-acquisition procedure and an advanced event reconstruction algorithm was deployed. The search was conducted in the Northern Hemisphere of the sky, i.e. by detecting neutrinos from "below", so that Earth could screen background atmospheric muons.

Three different searches were carried out to locate possible point-like neutrino sources. The first involved scanning the sky for a statistically significant excess over background, while the other two used a catalogue of 110 sources that was developed in the 2020 study, the difference between the two being the statistical methods used. The results showed an excess of

79^{+22}_{-20} muon-neutrino events, with the main contribution coming from neutrinos in the energy range of 1.5 to 15 TeV, while the all-flavour flux is expected to be a factor of three higher. All the events contributing to the excess were well-reconstructed within the detector, with no signs of anomalies, and the results were found not to be dominated by just one or a few individual events. The results were also in line with phenomenological models that predict the production of neutrinos and gamma rays in sources such as NGC1068.

IceCube's measurements usher in a new era of neutrino astronomy and take researchers a step closer to understanding not only the origin of high-energy cosmic rays but also the immense power of massive black holes, such as the one residing inside NGC1068.

Further reading

IceCube Collab. 2022 *Science* **378** 538.
MG Aartsen et al. 2020 *Phys. Rev. Lett.* **124** 051103.

NEWS DIGEST

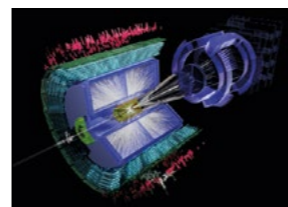

A lead-lead collision at LHC Run 3.

Run 3 ions set record

During the penultimate week of accelerator operations before the CERN year-end-technical stop, heavy ions returned to the LHC after a gap of four years. On 18 November, lead nuclei were accelerated and collided at a record energy of 5.36 TeV per nucleon-nucleon collision. The three-day-long test run was an important milestone in preparing physics runs with lead-lead collisions in 2023 and beyond. Upgrades to the ion injector complex will allow a doubling of the total intensity of the lead-ion beams for the High-Luminosity LHC. Achieving this goal requires a technique called momentum slip-stacking to be used in the SPS, where two batches of four lead-ion bunches separated by 100 nanoseconds "slip" to produce a single batch of eight lead bunches separated by 50 nanoseconds. Having now finished and tested all upgrades, the LHC will provide a 10-fold higher number of heavy-ion collisions with respect to previous runs.

Muonium Lamb shift

As a bound state of an antimuon and an electron, muonium is an ideal system to test quantum electrodynamics due to the point-like structure of the electron and muon. Recent measurements of muonium at the Paul Scherrer Institute (PSI) bring high-precision determinations of the muonium Lamb shift within reach. The ETH Zurich/PSI team measured the $2S_{1/2}$, $F=0 \rightarrow 2P_{1/2}$, $F=1$ transition to be 580.6(6.8) MHz, in agreement with theoretical calculations,

enabling a value of the Lamb shift of 1045.5(6.8) MHz to be extracted. Pushing the precision higher with upgraded PSI beamlines will test quantum electrodynamics, in particular bound-state recoil corrections, at a level beyond what is possible in hydrogen, say the researchers (*Nat. Commun.* **13** 7273).

CAST-CAPP restricts axions

The CAST experiment at CERN was originally designed to hunt for solar axions, which may be converted into X-rays in a strong magnetic field. In a new study, the CAST team placed a resonator consisting of four cavities inside one of the two bores of the experiment's magnet to look instead for these hypothetical particles in the dark-matter halo of the Milky Way. The "CAST-CAPP" haloscope can be tuned to pick up signals ranging from 4.774 to 5.434 GHz, corresponding to axion masses between 19.74 and 22.47 μeV . A 4124 hr scan of this frequency band excluded axion-photon couplings for galactic axions down to $g_{a\gamma} = 8 \times 10^{-14} \text{ GeV}^{-1}$ at 90% confidence level (*Nat. Commun.* **13** 6180).

FAIR evaluation

In a report published on 25 October, a team of external experts led by former CERN Director-General Rolf-Dieter Heuer evaluated the science programme, finances and schedule of the FAIR accelerator facility in Germany. The panel concludes that no other facility now being planned or under construction can carry out the full scientific programme in nuclear physics planned for FAIR. It also suggests a stepwise approach for the realisation of the project, recognising that, as a consequence of various unforeseeable developments, additional costs are unavoidable to reach the first step of viable operation. On 30 November, FAIR announced the installation of its centrepiece "coldbox" – the cooling system for the superconducting accelerator magnets.

Flying to the Moon

Launched on 16 November as the first of a series of missions by NASA to reinvigorate human space exploration, Artemis I carried four chips developed by the CERN-hosted Medipix2 collaboration. Particles interacting with the compact, pixelated "Timepix" sensors can be classified according to their characteristic shape, providing information about the radiation spectrum in harsh environments such as space and helping researchers predict solar storms and other space events.



The multipurpose hybrid pixel detector chip Timepix3.

The launch came 10 years after the first Timepix chip was flown as a technology demo on the International Space Station in October 2012. NASA's new Hybrid Electronic Radiation Assessor (HERA) radiation detector, composed of three Timepix devices, is now a standard component in the Artemis programme.

Europe boosts space funding

On 23 November ESA announced a budget increase of 17% compared to 2019 to strengthen its autonomy, leadership and sustainability in space. Among its ambitious programme, and on time for launch in 2023, are JUICE (which will explore the possibility of life on Jupiter) and Euclid, which will observe billions of galaxies through 10 billion years of cosmic time. The funding increase will also continue the development of ESA's Plato and Ariel missions, which are set to launch later this decade to study extrasolar

planets. "When faced with economic hardship, it is important to invest wisely in industries that create jobs and prosperity in Europe," said ESA director general Josef Aschbacher.

COVID damage revealed at ESRF

An international team has used advanced X-ray imaging techniques at the ESRF in Grenoble to examine damaged lungs of COVID-19 patients. The results showed a heterogeneously distributed mosaic-like pattern of lung damage and demonstrated that long-term changes in the lungs due to COVID-19 are driven by micro clots and the formation of new blood vessels. The results suggest that treatments aiming at preventing microvascular thrombosis and tissue ischemia may benefit patients with severe COVID-19 symptoms and avoid subsequent fibrotic remodelling, says the team (*eBioMedicine* **85** 104296).

AI vs humans

Until recently, artificial intelligence (AI) algorithms lacked success in strategy games where communication is an important ingredient to win. A team at Meta changed this situation by creating an algorithm called Cicero to anticipate and react to players' behaviour in a strategy game called *Diplomacy*. The algorithm uses a pre-trained language model, which was further trained based on message exchanges in human games to reach human-level performance. Strategic reasoning to select intentions and actions helped the AI during 72 hours of play to be placed among the best 10% of players who played the game more than one time. Although the AI occasionally got decisions wrong, human players were not aware that they were playing against an AI according to in-game messages (*Science* **378** 1067).

Reports from the Large Hadron Collider experiments

CMS

Hunting dark matter with invisible Higgs decays

In the Standard Model (SM) of particle physics, the only way the Higgs boson can decay without leaving any traces in the LHC detectors is through the four-neutrino decay, $H \rightarrow ZZ \rightarrow 4\nu$, which has an expected branching fraction of only 0.1%. This very small value can be seen as a difficulty but is also an exciting opportunity. Indeed, several theories of physics beyond the SM predict considerably enhanced values for the branching fraction of invisible Higgs-boson decays. In one of the most interesting scenarios, the Higgs boson acts as a portal to the dark sector by decaying to a pair of dark matter (DM) particles. Measurements of the “Higgs to invisible” branching fraction are clearly among the most important tools available to the LHC experiments in their searches for direct evidence of DM particles.

The CMS collaboration recently reported the combined results of different searches for invisible Higgs-boson decays, using data collected at 7, 8 and 13 TeV centre-of-mass energies. To find such a rare signal among the overwhelming background produced by SM processes, the study considers

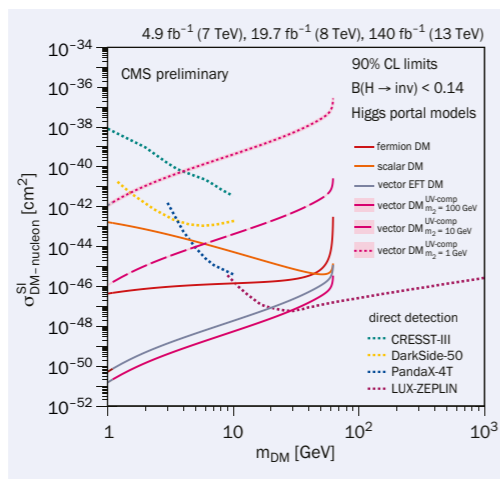

Fig. 1. The DM–nucleon coupling strength derived from the new CMS result, in the context of several models, as a function of the DM candidate mass. Limits from direct-detection experiments are also shown for comparison.

events in most Higgs-boson production modes: via vector boson (W or Z) fusion, via gluon fusion and in association with a top quark-antiquark pair or a vector

boson. In particular, the analysis looked at hadronically decaying vector bosons or top quark-antiquark pairs. A typical signature for invisible Higgs-boson decays is a large missing energy in the detector, so that the missing transverse energy plays a crucial role in the analysis. No significant signal has been seen, so a new and stricter upper limit is set on the probability that the Higgs boson decays to invisible particles: 15% at 95% confidence level.

This result has been interpreted in the context of Higgs-portal models, which introduce a dark Higgs sector and consider several dark Higgs-boson masses. The extracted upper limits on the spin-independent DM-nucleon scattering cross section, shown in figure 1 for a range of DM mass points, have better sensitivities than those of direct searches over the 1–100 GeV range of DM masses. Once the Run 3 data will be added to the analysis, much stricter limits will be reached or, if we are lucky, evidence for DM production at the LHC will be seen.

Further reading
CMS Collab. 2022 CMS-PAS-HIG-21-007.

ATLAS

Testing flavour symmetry with the Higgs boson

Lepton number is a quantum number that represents the difference in the number of leptons and antileptons participating in a process, while lepton flavour is a corresponding quantity that accounts for each generation of lepton (e, μ or τ) separately. Lepton number is always conserved but lepton flavour violation (LFV) is known to exist in nature, as this phenomenon has been observed in neutrino oscillations – the transition of a neutral lepton of a given flavour to one with a different flavour. This observation motivates searches for additional manifestations of LFV that may be the result of beyond-the-Standard Model (SM) physics, key among which is the search for LFV decays of the Higgs boson.

The ATLAS collaboration has recently

The observed upper limits on the branching fractions are the most stringent limits obtained by the ATLAS experiment

announced the results of searches for $H \rightarrow e\tau$ and $H \rightarrow \mu\tau$ decays based on the full Run 2 data set, which was collected at a centre-of-mass energy of 13 TeV. The unstable τ lepton decays to an electron or a muon and two neutrinos, or to one or more hadrons and one neutrino. Most of the background events in these searches arise from SM processes such as $Z \rightarrow \tau\tau$, the production of top-antitop

and weak-boson pairs, as well as from events containing misidentified or non-prompt leptons (fake leptons). These fake leptons originate from secondary decays, for example of charged pions. Several multivariate analysis techniques were used for each final state to provide the maximum separation between signal and background events.

To ensure the robustness of the measurement, two background estimation methods were employed: a Monte Carlo (MC) template method in which the background shapes were extracted from MC and normalised to data, and a “symmetry method”, which used only the data and relied on an approximate symmetry between prompt electrons and prompt muons. Any difference between the branching fractions $B(H \rightarrow e\tau_\mu)$ and Δ

$B(H \rightarrow \mu\tau_\mu)$, where the subscripts μ and e represent the decay modes of the τ lepton, would break this symmetry. In both cases, contributions from events containing fake leptons were estimated directly from the data.

The MC-template method enables the measurement of the branching ratios of the LFV decay modes. Searches based on the MC-template method for background estimation involve both leptonic and hadronic decays of τ leptons. A simultaneous measurement of the $H \rightarrow e\tau$ and $H \rightarrow \mu\tau$ decay modes was performed. For the $H \rightarrow \mu\tau$ ($H \rightarrow e\tau$) search, a 2.5 (1.6) standard deviation upward fluctuation above the SM background prediction is observed. The observed (expected) upper limits on the branching fractions $B(H \rightarrow e\tau)$ and $B(H \rightarrow \mu\tau)$ at 95% confidence level are slightly below 0.2% (0.1%), which are the most stringent limits obtained by the ATLAS experiment on these quantities. The result of the simultaneous measurement of the $H \rightarrow e\tau$ and $H \rightarrow \mu\tau$

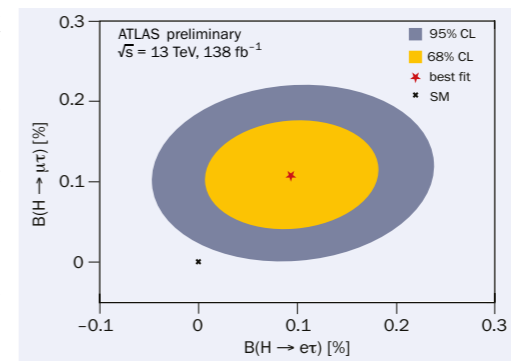

Fig. 1. Best-fit value (red star) of the branching ratios $B(H \rightarrow e\tau)$ and $B(H \rightarrow \mu\tau)$, given in %, and likelihood contours at 68% (yellow) and 95% (grey) confidence levels, obtained from the simultaneous measurement of $H \rightarrow e\tau$ and $H \rightarrow \mu\tau$ signals based on the MC-template method, compared to the Standard Model expectation (black cross).

branching fractions is compatible with the SM prediction within 2.2 standard deviations (see figure 1).

The symmetry method is particularly sensitive to the difference in the two LFV decay branching ratios. For this measurement, only the fully leptonic final states were used. Special attention was paid to correctly account for asymmetries induced by the different detector response to electrons and muons, especially regarding the trigger and offline efficiency values for lepton reconstruction, identification and isolation, as well as regarding contributions from fake leptons. The measurement of the branching ratio difference indicates a small but not significant upward deviation for $H \rightarrow \mu\tau$ compared to $H \rightarrow e\tau$. The best-fit value for the difference between $B(H \rightarrow \mu\tau_\mu)$ and $B(H \rightarrow e\tau_\mu)$ is $(0.25 \pm 0.10)\%$.

The expected twice-larger LHC Run 3 dataset at the higher centre-of-mass energy of 13.6 TeV will shed further light on these results.

Further reading
ATLAS Collab. 2022 ATLAS-CONF-2022-060.

LHCb

B to D decays reduce uncertainty on γ

The Cabibbo-Kobayashi-Maskawa (CKM) matrix describes the couplings between the quarks and the weak charged current, and contains within it a phase γ that changes sign under consideration of antiquarks rather than quarks. In the Standard Model (SM), this phase is the only known difference in the interactions of matter and anti-matter, a consequence of the breaking of charge-parity (CP) symmetry. While the differences within the SM are known to be far too small to explain the matter-dominated universe, it is still of paramount importance to precisely determine this phase to provide a benchmark against which any contribution from new physics can be compared.

A new measurement recently presented by the LHCb collaboration uses a novel method to determine γ using decays of the type $B^\pm \rightarrow D[K^\mp \pi^\pm \pi^\mp] h^\pm$ ($h = \pi, K$). CP violation in such decays is a consequence of the interference between two tree-level processes with a weak phase that differs by γ , and thus provide a theoretically clean probe of the SM. The new aspect of this measurement compared to those performed previously lies in the partitioning of the five-dimensional phase space of the D-decay into a series of independent regions, or bins. In these bins, the asymmetries between B^+ and B^- meson decay rates

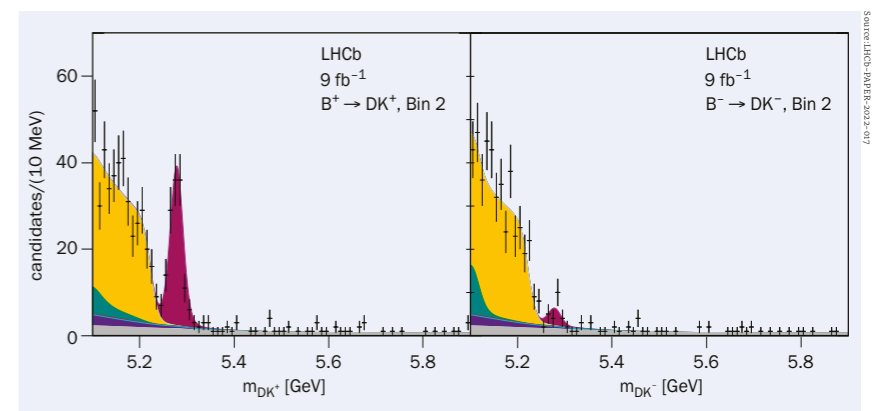

Fig. 1. Distribution of B^+ and B^- to DK^+ candidates, where the contribution from correctly reconstructed decays can be seen in magenta, in one bin of the D-meson decay phase space bins. The large CP violation is clearly visible as a difference in height between the two peaks.

can receive large enhancements from the hadronic interactions in the D-meson decay. The enhancement for one of such bins can be seen in figure 1, which shows the invariant mass spectrum of the B^+ and B^- meson candidates, where the correctly reconstructed decays peak at around 5.3 GeV. The observed asymmetry in this region is around 85%, which is the largest difference in the behaviour of matter and antimatter ever measured. Observables from the differ-

ent bins are combined with information on the hadronic interactions in the D-meson decay from charm-threshold experiments to obtain $\gamma = 55 \pm 9^\circ$, which is compatible with previous determinations and is the second most precise single measurement.

The LHCb average value of γ is then determined by combining this analysis with the measurements in many other B and D decays, where in all cases the SM contribution is expected to be dom-

inant. Measurements of charm decays are also included to better constrain both the parameters of charm mixing, which also play an important role in the measurements of B-meson decays at the current level of precision and help to constrain the hadronic interactions in some of the D decays. In particular, included for the first time in this combination is a measurement of γ_{CP} , which is proportional to the difference in lifetimes of the two neutral charm mesons, and was determined using two-body decays of the D meson using the entire LHCb data set collected so far.

The overall impact of these additional analyses reduces the uncertainty on γ by

The matter–antimatter asymmetry reaches 85% in a certain region, the largest ever observed

more than 10%, corresponding to adding around a year of data taking across all decay modes.

The improvements in the knowledge of γ_{CP} is also dramatic, reducing the uncertainty by around 40%. While the value of γ is found to be compatible with determinations that would be more susceptible

to new physics, the precision of the comparison is starting to approach the level of a few degrees, at which discrepancies may start to be observable.

Given that the current uncertainties on many of the key input analyses to the combination are predominately statistical in nature, measurements of these fundamental flavour-physics parameters with the upgraded LHCb detector, and beyond, are an intriguing prospect for new-physics searches.

Further reading

LHCb Collab. 2022 LHCb-PAPER-2022-017.
LHCb Collab. 2022 LHCb-CONF-2022-002.
LHCb Collab. 2022 LHCb-PAPER-2021-041.

ALICE

Hidden charm in the quark–gluon plasma

For almost 40 years, charmonium, a bound state of a heavy charm–anticharm pair (hence also called a hidden charm), has provided a unique probe to study the properties of the quark–gluon plasma (QGP), the state of matter composed by deconfined quarks and gluons present in the early instants of the universe and produced experimentally in ultrarelativistic heavy-ion collisions. Charmonia come in a rich variety of states. In a new analysis investigating how these different bound charmonium states are affected by the QGP, the ALICE collaboration has opened a novel way to study the strong interaction at extreme temperatures and densities.

In the QGP, the production of charmonium is suppressed due to “colour screening” by the large number of quarks and gluons present. The screening, and thus the suppression, increases with the temperature of the QGP and is expected to affect different charmonium states to different degrees. The production of the $\psi(2S)$ state, for example, which is 10 times more weakly bound and two times larger in size than the most tightly bound state, the J/ψ , is expected to be more suppressed.

This hierarchical suppression is not the only fate of charmonia in the quark–gluon plasma. The large number of charm quarks and antiquarks in the plasma – up to about 100 in head-on lead–lead collisions – also gives rise to a mechanism, called recombination, that forms new charmonia and counters the suppression to a certain extent. This process is expected to depend on the type and momentum of the charmonia, with the more weakly bound charmonia being pro-

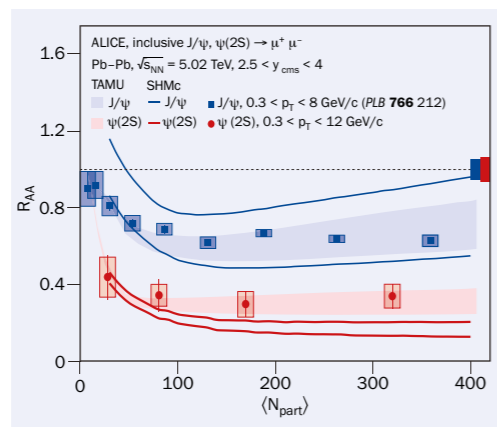

Fig. 1. The J/ψ (blue) and $\psi(2S)$ (red) nuclear modification factor (R_{AA}) as a function of centrality, quantified by the average number of nucleons participating in the collision ($\langle N_{part} \rangle$). The line at $R_{AA} = 1$ corresponds to the absence of modification between lead–lead and proton–proton interactions. Comparisons with the TAMU and SHMc models are also shown.

duced through recombination later in the evolution of the plasma and charmonia with the lowest (transverse) momentum having the highest recombination rate.

Previous studies, using data first from the Super Proton Synchrotron and then from the LHC, have shown that the production of the $\psi(2S)$ state is indeed more suppressed than that of the J/ψ , and ALICE has also previously provided evidence of the recombination mechanism in J/ψ production. But so far, no studies of $\psi(2S)$ production at low transverse particle momentum had been precise enough to provide conclusive results in this momentum regime, preventing

a complete picture of $\psi(2S)$ production from being obtained.

The ALICE collaboration has now reported the first measurements of $\psi(2S)$ production down to zero transverse momentum, based on lead–lead collision data from the LHC collected in 2015 and 2018. The results indicate that the $\psi(2S)$ yield is largely suppressed with respect to a proton–proton baseline, almost a factor of two more suppressed than the J/ψ . The suppression, shown as a function of the collision centrality (N_{part}) in the figure, is quantified through the nuclear modification factor (R_{AA}), which compares the particle production in lead–lead collisions with respect to the expectations based on proton–proton collisions.

Theoretical predictions based on a transport approach that includes suppression and recombination of charmonia in the QGP (TAMU) or on the Statistical Hadronisation Model (SHMc), which assumes charmonia to be formed only at hadronisation, describe the J/ψ data, while the $\psi(2S)$ production is underestimated in central events by the SHMc. This observation represents one of the first indications that dynamical effects in the QGP, as taken into account in the transport models, are needed to reproduce the yields of the various charmonium states. It also shows that precision studies, including these and those of other charmonia, and foreseen for Run 3 of the LHC, may lead to a final understanding of the modification of the force binding these states in the extreme environment of the QGP.

Further reading

ALICE Collab. 2022 arXiv:2210.08893.

FIELD NOTES

Reports from events, conferences and meetings

PHYSICS BEYOND COLLIDERS

Preparing for post-LS3 scenarios

The Physics Beyond Colliders (PBC) study was launched in 2016 to explore the opportunities offered by CERN’s unique accelerator and experimental-area complex to address some of the outstanding questions in particle physics through experiments that are complementary to the high-energy frontier. Following the recommendations of the 2020 update of the European strategy for particle physics, the CERN directorate renewed the mandate of the PBC study, continuing it as a long-term activity.

The fourth PBC annual workshop took place at CERN from 7 to 9 November 2022. The aim was to review the status of the studies, with a focus on the programmes under consideration for the start of operations after Long Shutdown 3 (LS3), scheduled for 2026–2029.

The North Area (NA) at CERN, where experiments are driven by beams from the Super Proton Synchrotron (SPS), is at the heart of many present and proposed explorations for physics beyond the Standard Model. The NA includes an underground cavern (ECN3), which can host unique high-energy/high-intensity proton beams. Several proposals for experiments have been made, all of which require higher intensity proton beams than are currently available. It is therefore timely to identify the synergies and implications of a future ECN3 high-intensity programme on the otherwise ongoing NA technical consolidation programme.

The following proposals are being considered within the PBC study group:

- HIKE (High Intensity Kaon Experiment) is a proposed expansion of the current NA62 programme to study extremely rare decays of charged kaons and, in a second phase, those of neutral kaons. This would be complemented by searches for visible decays of feebly interacting particles (FIPs) that could emerge on-axis from the dump of an intense proton beam within a thick absorber that would contain all other known particles, except muons and neutrinos;
- SHADOWS (Search for Hidden And Dark Objects With the SPS) would search for visible FIP decays off-axis



Future physics New experimental programmes proposed at CERN’s North Area, including a high-intensity beam facility in the ECN3 cavern, are a focus of current PBC studies.

The North Area at CERN is at the heart of many present and proposed explorations for physics beyond the Standard Model

and could run in parallel to HIKE when operated in beam-dump mode. The proposed detector is compact and employs existing technologies to meet the challenges of reducing the muon background;

- SHiP (Search for Hidden Particles) would allow a full investigation of hidden sectors in the GeV mass range. Comprehensive design studies for SHiP and the Beam Dump Facility (BDF) in a dedicated experimental area were published in preparation for the European strategy update. During 2021, an analysis of alternative locations using

existing infrastructure at CERN revealed ECN3 to be the most promising option;

- Finally, TauFV (Tau Flavour Violation) would conduct searches for lepton–flavour violating tau–lepton decays.

The HIKE, SHADOWS and BDF/SHiP collaborations have recently submitted letters of intent describing their proposals for experiments in ECN3. The technical feasibility of the experiments, their physics potential and implications for the NA consolidation are being evaluated in view of a possible decision by the beginning of 2023. A review of the experimental programme in the proposed high-intensity facility will take place during 2023, in parallel with a detailed comparison of the sensitivity to FIPs in a worldwide context.

A vibrant programme

The NA could also host a vibrant ion–physics programme after LS3, with NA60++ aiming to measure the calorimetric curve of the strong-force phase transition with lead–ion beams, and NA61++ proposing to explore the onset of the deconfined nuclear medium, extending the scan in the momentum/ion space with collisions of lighter ion beams. The conceptual implementation of such schemes in the accelerators and experimental area is being studied and the results, together with the analysis of the physics potential, are expected during 2023.

The search for long-lived particles with dedicated experiments and the exploration of fixed-target physics is also open at the LHC. The proposed forward-physics facility, located in a cavern that could be built at a distance of 600 m along the beam direction from LHC Interaction Point 1, would take advantage of the large flux of high-energy particles produced in the very forward direction in LHC collisions. It is proposed to host a comprehensive set of detectors (FASER2, FASERv2, AdvSND, FORMOSA, FLARe) to explore a broad range of new physics and to study the highest energy neutrinos produced by accelerators (CERN Courier July/August 2021 p7). A conceptual design report >

of the facility, including detector design, background analysis and mitigation measures, civil engineering and integration studies is in preparation. Small prototypes of the MATHUSLA, ANUBIS and CODEX-b detectors aiming at the search for long-lived particles at large angles from LHC collisions are also being built for installation during the current LHC run.

The technology know-how at CERN can also benefit non-accelerator experiments

A gas-storage cell (SMOG2) was installed in front of the LHCb experiment during the last LHC long shutdown (CERN Courier May/June 2020

p20), opening the way to high-precision fixed-target measurements at the LHC. The storage cell enhances the density of the gas and therefore the rate of the collisions by up to two orders of magnitude as compared to the previous internal gas target. SMOG2 has been successfully commissioned with neon gas, demonstrating that it can be operated in parallel to LHCb. Future developments include the injection of different types of gases and a polarised gas target to explore nucleon spin-physics at the LHC.

Crystal clear

Fixed-target experiments are also being developed that would extract protons from LHC beams by channelling the beam halo with a bent crystal. The extracted protons would impinge on a target and be used for measurements of proton structure functions (“single crystal setup”) or estimation of the magnetic and electric dipole moments of short-lived heavy baryons (“double crystal setup”). In the latter case, the measurement would be based on the baryon spin precession in the strong electric field of a second bent crystal installed immediately downstream from the baryon-production proton target. A proof-of-principle experiment of the double-crystal setup is being designed for installation in the LHC to determine the channelling efficiency for long crystals at TeV energies, as well as to demonstrate the control and management of the secondary halo and validate the estimate of the achievable luminosity.

The technology know-how and experience available at CERN can also benefit non-accelerator experiments such as the Atom Interferometer Observatory and Network (AION), proposed to be installed in one of the shafts at Point 4 of the LHC for mid-frequency gravitational-wave detection and ultra-light dark-matter searches (CERN Courier March/April 2021 p10), as well as the development of superconducting cavities for the Relic Axion Detector Experimental Setup (RADES) and for the heterodyne detection of axion-like particles.

During the workshop, progress on the possible applications of a gamma factory at CERN (CERN Courier November 2017 p7), as well as the status of the design of a Charged-Particle EDM Prototype Ring (CERN Courier September 2016 p27) and of the R&D for novel monitored or tagged neutrino beamlines, were also presented.

Gianluigi Arduini CERN, **Joerg Jaeckel** Heidelberg University and **Claude Vallée** CPPM, Marseille.

QT4HEP

Combining quantum with high-energy physics

From 1 to 4 November, the first International Conference on Quantum Technologies for High-Energy Physics (QT4HEP) was held at CERN. With 224 people attending in person and many more following online, the event brought together researchers from academia and industry to discuss recent developments and, in particular, to identify activities within particle physics that can benefit most from the application of quantum technologies.

Opening the event, Joachim Mnich, CERN director for research and computing, noted that CERN is widely recognised, including by its member states, as an important platform for promoting applications of quantum technologies for both particle physics and beyond. “The journey has just begun, and the road is still long,” he said, “but it is certain that deep collaboration between physicists and computing experts will be key in capitalising on the full potential of quantum technologies.”

The conference was organised by the CERN Quantum Technology Initiative (CERN QTI), which was established in 2020 (CERN Courier September/October 2020 p47), and followed a successful workshop on quantum computing in 2018 that marked the beginning of a range of new investigations into quantum technologies at CERN. CERN QTI covers four main research areas: quantum theory and simulation; quantum sensing, metrology and materials; quantum computing and algorithms; and quantum communication and networks. The first day’s sessions focused on the first two: quantum theory and simulation, as well as quantum sensing, metrology and materials. Topics covered included the quantum simulation of neutrino oscillations, scaling up atomic interferometers for the detection of dark matter, and the application of quantum traps and clocks to new-physics searches.

Building partnerships

Participants showed an interest in broadening collaborations related to particle physics. Members of the quantum theory and quantum sensing communities discussed ways to identify and promote areas of promise relevant to CERN’s scientific programme. It is clear that many detectors in particle physics can be enhanced – or even made possible – through targeted R&D in quantum technologies. This fits well with ongoing efforts to implement a chapter on



Quantum leap
CERN QTI head Alberto Di Meglio speaking at the QT4HEP event, supported through CERN Openlab and sponsored by Google, IBM and Intel.

quantum technologies in the European Committee for Future Accelerators’ R&D roadmap for detectors, noted Michael Doser, who coordinates the branch of CERN QTI focused on sensing, metrology and materials.

For the theory and simulation branch of CERN QTI, the speakers provided a useful overview of quantum machine learning, quantum simulations of high-energy collider events and neutrino processes, as well as making quantum-information studies of wormholes testable on a quantum processor (p54). Elina Fuchs, who coordinates this branch of CERN QTI, explained how quantum advantages have been found for toy models of increased physical relevance. Furthermore, she said, developing a dictionary that relates interactions at high energies to lower energies will enhance knowledge about new-physics models learned from quantum-sensing experiments.

The second day’s sessions focused on the remaining two areas, with talks on quantum-machine learning, noise gates for quantum computing, the journey towards a quantum internet, and much more. These talks clearly demonstrated the importance of working in interdisciplinary, heterogeneous teams when approaching particle-physics research with quantum-computing techniques. The technical talks also showed how studies on the algorithms are becoming more robust, with a focus on trying to address problems that are as realistic as possible.

A keynote talk from Yasser Omar, president of the Portuguese Quantum Institute, presented the “fleet” of programmes on quantum technologies that has been launched since the EU Quantum Flagship was announced in 2018.

In particular, he highlighted QuantERA, a network of 39 funding organisations

from 31 countries; QuIC, the European Quantum Industry Consortium; EuroQCI, the European Quantum Communication Infrastructure; EuroQCS, the European Quantum Computing and Simulation Infrastructure; and the many large national quantum initiatives being launched across Europe. The goal, he said, is to make Europe autonomous in quantum technologies, while remaining open to international collaboration. He also highlighted the role of World Quantum Day – founded in 2021 and celebrated each year on 14 April – in raising awareness around the world of quantum science.

Jay Gambetta, vice president of IBM Quantum, gave a fascinating talk on the path to quantum computers that exceed the capabilities of classical computers. “Particle physics is a promising area for looking for near-term quantum advantage,” he said. “Achieving this is going to take both partnership with experts in quantum information science and particle physics, as well as access to tools that will make this possible.”

Industry and impact

The third day’s sessions – organised in collaboration with CERN’s knowledge transfer group – were primarily dedicated to industrial co-development. Many of the extreme requirements faced by quantum technologies are shared with particle physics, such as superconducting materials, ultra-high vacuum, precise timing, and much more. For this reason, CERN has built up a wealth of expertise and specific technologies that can directly address challenges in the quantum industry. CERN strives to maximise the impact of all of its technologies and know-how on society in many ways to ease the transfer of CERN’s knowledge to industry and society. One focus is to see which technologies might help to build robust quantum-computing devices. Already, CERN’s White Rabbit technology, which provides sub-nanosecond accuracy and picosecond precision of synchronisation for the LHC accelerator chain, has found its way to the quantum community, noted Han Dols, business development and entrepreneurship section leader.

Several of the day’s talks focused on challenges around trapped ions and control systems. Other topics covered included the potential of quantum computing for drug development, measuring brain function using quantum

FIELD NOTES

FIELD NOTES

sensors, and developing specialised instrumentation for quantum computers. Representatives of several start-up companies, as well as from established technology leaders, including Intel, Atos and Roche, spoke during the day. The end of the third day was dedicated to crucial education, training and outreach initiatives. Google provided financial support for 11 students to attend the conference, and many students and researchers presented posters.

Marieke Hood, executive director for corporate affairs at the Geneva Science and Diplomacy Anticipator (GESDA) foundation, also gave a timely presentation about the recently announced Open Quantum Institute (OQI). CERN is part of a coalition of science and industry partners proposing the creation of this institute, which will work to ensure that emerging quantum technologies tackle key societal challenges. It was launched

at the 2022 GESDA Summit in October, during which CERN Director-General Fabiola Gianotti highlighted the potential of quantum technologies to help achieve key UN Sustainable Development Goals. “The OQI acts at the interface of science and diplomacy,” said Hood. “We’re proud to count CERN as a key partner for OQI, its experience of multinational collaboration will be most useful to help us achieve these ambitions.”

The final day of the conference was dedicated to hands-on workshops with three different quantum-computing providers. In parallel, a two-day meeting of the “Quantum Computing 4HEP” working group, organised by CERN, DESY and the IBM Quantum Network, took place.

Qubit by qubit

Overall, the QT4HEP conference demonstrated the clear potential of different quantum technologies to

The conference demonstrated the clear potential of different quantum technologies to impact upon particle-physics research

impact upon particle-physics research. Some of these technologies are here today, while others are still a long way off. Targeted collaboration across disciplines and the academia-industry interface will help ensure that CERN’s research community is ready to maximise on the potential of these technologies.

“Widespread quantum computing may not be here yet, but events like this one provide a vital platform for assessing the opportunities this breakthrough technology could deliver for science,” said Enrica Porcari, head of the CERN IT department. “Through this event and the CERN QTI, we are building on CERN’s tradition of bringing communities together for open discussion, exploration, co-design and co-development of new technologies.”

Andrew Purcell CERN openlab.

SUPERCONDUCTING DETECTOR MAGNETS WORKSHOP

Superconducting detector magnets for the future

The Superconducting Detector Magnets Workshop, co-organised by CERN and KEK, was held at CERN from 12 to 14 September in a hybrid format. Joining were 90 participants from 36 different institutes and companies, with 57 on-site and 33 taking part remotely.

The workshop aimed to bring together the physics community, detector-magnet designers and industry to exchange ideas and concepts, foster collaboration, and to discuss the needs and R&D goals for future superconducting detector magnets. A key aim was to address the issue of the commercial availability of aluminium-stabilised Nb-Ti/Cu conductor technology.

Fifteen physics-experiment projects, which had either been approved or are in the design phase, presented their needs and plans for superconducting detector magnets. These experiments covered a wide range of physics programmes for existing and future colliders, non-colliders and a space-based experiment. The presented projects showed a strong demand for aluminium-stabilised Nb-Ti/Cu conductor technology. Other conductor technologies that were featured during the workshop included cable-in-conduit technology (CICC) and aluminium-stabilised high-temperature-superconducting (HTS) technology.

Presentations by leading industrial partners showed that the industrial capability to produce superconducting detector magnets does exist, as long as



One of a kind
The large Nb-Ti superconducting magnet of the CMS detector being installed in 2007.

a suitable conductor is available. It was also shown that aluminium-stabilised Nb-Ti/Cu conductors are currently not commercially available, although an R&D effort is currently on-going with IHEP in China. In particular, the co-extrusion process needed to clad the Nb-Ti/Cu Rutherford cable with aluminium is a key missing ingredient in industry. At the same time, the presentations showed that other ingredients, such as Nb-Ti/Cu wire production, the cabling of strands into Rutherford cables, the high-purity aluminium stabiliser itself and the technique for welding aluminium-alloy reinforcements for high-strength conductors are still available.

The main conclusion of the workshop was that, given the need for aluminium-stabilised Nb-Ti/Cu conductors for future superconducting detector magnet projects, it is important that the commercial availability of this conductor is re-established, which would require a leading effort from international institutes through collaboration and cooperation with industry. This world-leading effort will advance technologies to be transferred openly to industry and other laboratories. Of particular importance is the co-extrusion technology needed to bond the aluminium stabiliser to the Rutherford cable. Hybrid-structure technology through electron-beam welding or other approaches to maximise the performance of an Al-stabilised superconductor combined with high-strength Al-alloy is needed for high-stress detector magnets. Back-up solutions such as copper-coated and soldered aluminium stabilisers, copper-based stabilisers and CICC should also be considered. In the long term, aluminium-stabilised HTS technology will be important for specific detector-magnet applications.

The workshop was received with strong interest and enthusiasm, and it is expected that another will be organised in one to two years, depending on the progress being made.

Matthias Mentink CERN,
Benoit Cure CERN, Toru Ogitsu KEK
and Akira Yamamoto KEK/CERN.

EPOL 2022

Exploring the power of polarisation at FCC-ee

FCC-ee, a proposed 91 km future circular e^+e^- collider at CERN foreseen to begin operations in the 2040s, would deliver enormous samples of collision data at a wide range of energies, allowing for ultra-precise studies of the Higgs, W and Z bosons, and the top quark. For example, when running at the Z resonance FCC-ee will produce – in little more than one minute – a data set the same size as that accumulated by the LEP collider during its entire 11 year-long period of operation. For this reason, unlocking the full potential of FCC-ee data will require exquisite systematic control at a level far beyond that achieved at previous colliders.

A beautiful and unique attribute of circular e^+e^- colliders is that the beams can naturally acquire transverse polarisation, and the precession frequency of the polarisation vector divided by the circulation frequency around the ring is directly proportional to the beam energy. This property allows the energy to be determined with very high precision by applying an oscillating magnetic field which, when in phase with the precession, depolarises the beams. This technique of resonant depolarisation underpins the precise knowledge of the mass and other properties of many particles that now serve as “standard candles”.

A key example is the measurement of the mass and width of the Z boson, and associated electroweak observables, which was the major achievement of the LEP programme. FCC-ee offers the possibility of improving the precision of these measurements by a factor of around 500 – a gigantic advance in precision that will allow for ultra-sensitive tests of the self-consistency of the Standard Model, and provide excellent sensitivity to new heavy particles that may affect the measurements through quantum corrections or mixing. Achieving the best possible knowledge of the collision energy is essential to accomplish this programme, and was the focus of the second

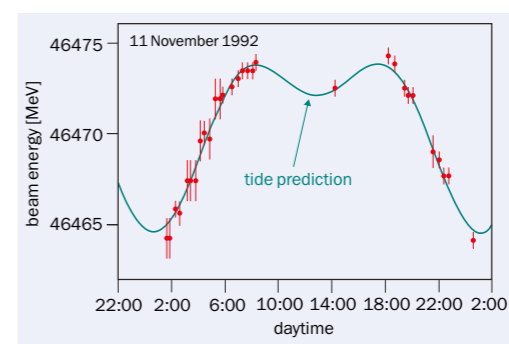

High tides

The evolution of the beam energy at LEP due to Earth tides, showing the measurements from resonant depolarisation (red points), and the predictions of a model. At FCC-ee the Earth tides, if uncorrected, will induce energy changes that are an order of magnitude larger.

FCC Energy Calibration, Polarisation and Mono-chromatisation (EPOL) workshop held at CERN from 19 to 30 September, which was a follow-up to the first workshop that took place in 2017.

The two-week workshop was attended by more than 100 accelerator physicists, particle physicists and engineers from around the world; some remote and others participating in person. Presentations focused not only on the challenges at FCC-ee, but also encompassed activities and initiatives at other facilities. The first week highlighted the plans for polarimetry measurements at the future Electron Ion Collider in the US. Complementary projects were presented from SuperKEKB in Japan, where the accelerator is stress-testing many aspects of the design for FCC-ee, CEPC in China and other machines around the world.

Earth tides

The collision-energy calibration is a central consideration in the design and proposed operation strategy of FCC-ee, in contrast to LEP where it was essentially an afterthought. At LEP, resonant depolarisation measurements were performed in dedicated calibration periods a few times per year. At FCC-ee these measurements will take place continually. This is essential, as a hard-learned lesson from LEP is

that the beam energy is not constant, but varies throughout a fill, and also evolves over longer timescales. The gravitational pull of the moon distorts the tunnel in “Earth tides”, and modifies the relative trajectory of the beam through the quadrupole magnets, leading to energy changes that at LEP were around 10 MeV over a few hours during Z running, but will be 20 times larger at FCC-ee. Seasonal changes in the water level of Lake Geneva lead to similar effects. At FCC-ee these distortions will be combated by continuous adjustment of the radio frequency (RF) cavities, as is now routinely done in the LHC.

Additional challenges that were discussed at the workshop included the requirements on the laser polarimeters that will monitor the polarisation levels of the e^+ and e^- beams, the shifts in collision energy that will occur at each interaction point through the combined effect of synchrotron radiation and the boost provided by the RF system, as well as spurious dispersions folded with collision offsets. Here the project will benefit from the considerable progress achieved since LEP in both the reliability and precision of beam position and dispersion measurements. A particular highlight of the discussions was an agreement that it will be feasible to perform resonant depolarisation measurements at higher energies for use in the determination of the mass of the W boson, which was not possible at LEP, allowing this important parameter of nature to be measured around a factor 20–40 times better than at present.

The workshop concluded with a list of future tasks to be tackled and open questions. These questions will be addressed as part of the ongoing FCC feasibility study, with updates planned for the mid-term review, scheduled for the middle of 2023, and the final report in 2025.

Alain Blondel University of Geneva,
Jacqueline Keintzel CERN and
Guy Wilkinson University of Oxford.

ITSF 2022

Keeping research infrastructures safe

Safety is a priority for CERN. It spans all areas of occupational health and well-being, including the protection of the environment and the safe operation of facilities. Continuous exchanges with similar research infrastructures on best practices and techniques ensures

that CERN maintains the highest standards. From 25 to 28 October, more than 100 people from CERN and research institutes worldwide gathered in the Globe of Science and Innovation at CERN for the International Technical Safety Forum (ITSF). This key confer-

We all learn from each other to create a safe work environment

ence in matters of health and safety is a forum for exchanging new ideas, processes, procedures and technologies in personnel, environmental and equipment safety, among a variety of high-energy physics, synchrotron and other research infrastructures. ▶

FIELD NOTES

FIELD NOTES



“In its 25-year existence, the forum has evolved with the times, all the while increasing its attractiveness for experts to share their knowledge, experience and challenges,” says Ralf Trant of the CERN technology department. “The scope has broadened from high-energy physics to a wider range of disciplines and participating institutes in Europe and beyond, with Asian labs joining in addition to American institutes, which have been involved since the beginning.”

Safe and sound
Safety experts from research infrastructures across the world met and shared their latest experiences and insights.

Sessions including continuous improvements in health and safety, fire safety, equipment certification, incidents and lessons learned, risk assessment and technical risks unfolded during the week, ending with new projects and challenges, safety culture and behaviour, and safety training.

“Listening to your colleagues from other research institutes on occurred events, lessons learned and recent developments in safety assessment is the pure essence of the ITSF,” said Peter Jakobsson, head of environment, safety, health and quality at ESS and member of the ITSF organising committee, who chaired the “Incidents and lessons learned” session. “We openly share information in different subject safety areas such as fire hazards, handling of chemicals and inspection of pressurised equipment. In doing so, we all learn from each other to create a safe work environment for our staff and scientific users: a true sign of the safety culture that we all strive for.”

In addition to a rich programme of presentations, the event featured an interactive fire workshop in which participants

shared ongoing projects and challenges related to fire safety in accelerator facilities. CERN also shared its experiences of the fire-induced radiological integrated assessment (FIRIA) project, whose objective is to develop a general methodology for assessing the fire-related risks present in CERN’s facilities and to provide a forum to keep experts connected and updated. Participants also enjoyed visits of the installations, complemented with a tour of the CERN safety training centre in Prévessin on the final day.

“This event gave us the possibility to share our knowledge through presentations but also through networking breaks, visits and social events,” said Yves Loertscher, head of the CERN occupational health and safety group and organiser of this year’s ITSF event. “After a break of almost three years owing to the pandemic, it is a pleasure to interact directly with peers again and share new ways of thinking and acting in matters of occupational health and safety and environmental protection.”

Anna Cook CERN.

EURO-LABS

Simplifying research across borders

European Laboratories for Accelerator Based Sciences (EURO-LABS) aims to provide unified transnational access to leading research infrastructures across Europe. Taking over from previously running independent programmes, it brings together the nuclear physics, high-energy accelerator and high-energy detector R&D communities. With 33 partners from European countries, EURO-LABS forms a large network of laboratories and institutes ranging from modest-sized test infrastructures to large-scale ESFRI facilities such as SPIRAL2. Its goal is to enable research at the technological frontiers in accelerator and detector development, and

to open wider avenues in both basic and applied research in diverse topics from the optimal running of reactors to mimicking reactions in the stars. Within this large network, EURO-LABS will ensure diversity and actively support researchers from different nationalities, gender, age, grade and variety of professional expertise.

Sharing information to support users at test facilities is pivotal. Targeted improvements such as new isotope-enriched targets for high-quality standard medical radioisotope production, improved beam-profile monitors, or magnetic-field measurement instruments in cryogenic conditions will

Sharing information to support users at test facilities is pivotal

further enhance the capabilities of facilities to address the challenges of the coming decades. Through an active and open data-management plan following the FAIR principle, EURO-LABS will act as a gateway for information to facilitate research across disciplines and provide training for young researchers.

Funded by the European Commission, EURO-LABS started on 1 September and will run until August 2026. At the kick-off meeting, held in Bologna from 3 to 5 October, presentations offered a detailed overview of the research infrastructures and facilities providing particle and ion beams at energies from meV to GeV. Exchanges during the meeting gave >

participants a view of the strengths and synergies on offer, planting the seeds for fruitful collaborations.

Prospects for testing and developing techniques for present and future accelerators were among the highlights of the meeting. In the high-energy accelerator sector, this requires state-of-the-art test benches for cryogenic equipment such as magnets, superconducting cavities and associated novel materials, electron and plasma beams, as well as specialised test-beam facilities. Facilities at CERN, DESY and PSI, for example, allow the study of performances and radiation effects on detectors for the HL-LHC and beyond, while also enabling nuclei to be explored under extreme conditions. Benefiting from past experiences, a streamlined procedure for handling transnational-access applications to all research infrastructures across the different fields of EURO-LABS was defined.

On the last day of the meeting, the consortium’s governing board, chaired by Edda Gschwendtner (CERN), met for the first time. The governing board further appointed Navin Alahari (GANIL,



Synergy Attendees of the EURO-LABS kick-off meeting mapped out a strategy for a European transnational access programme.

France) as EURO-LABS scientific coordinator, Paolo Giacomelli (INFN-BO, Italy) as project coordinator, Maria Colonna (INFN-LNS, Italy), Ilias Efthymiopoulos (CERN) and Marko Mikuz (Univ. Ljubljana, Slovenia) as deputy scientific coordinator and deputy work-package leader, and Maria J G Borge

(CSIC, Spain) and Adam Maj (IFJ, Poland) as work-package leaders.

With all the facilities declaring their readiness to receive the first transnational users, the next annual meeting will be hosted by IFJ-PAN in Krakow, Poland.

Ilias Efthymiopoulos CERN.

Need to Explore the World of Vacuum?

Use this map to navigate.



explore.agilent.com/vacuum-products-map

© Agilent Technologies, Inc. 2022



Learn more:
www.agilent.com/chem/vacuum
00 800 234 234 00 (toll-free) • vpt-customer@agilent.com



A NEW ATLAS FOR THE HIGH-LUMINOSITY ERA

Stefan Guindon, Christian Ohm and Caterina Vernieri describe the major ‘Phase II’ upgrades taking place to prepare the ATLAS detector for the High-Luminosity LHC.

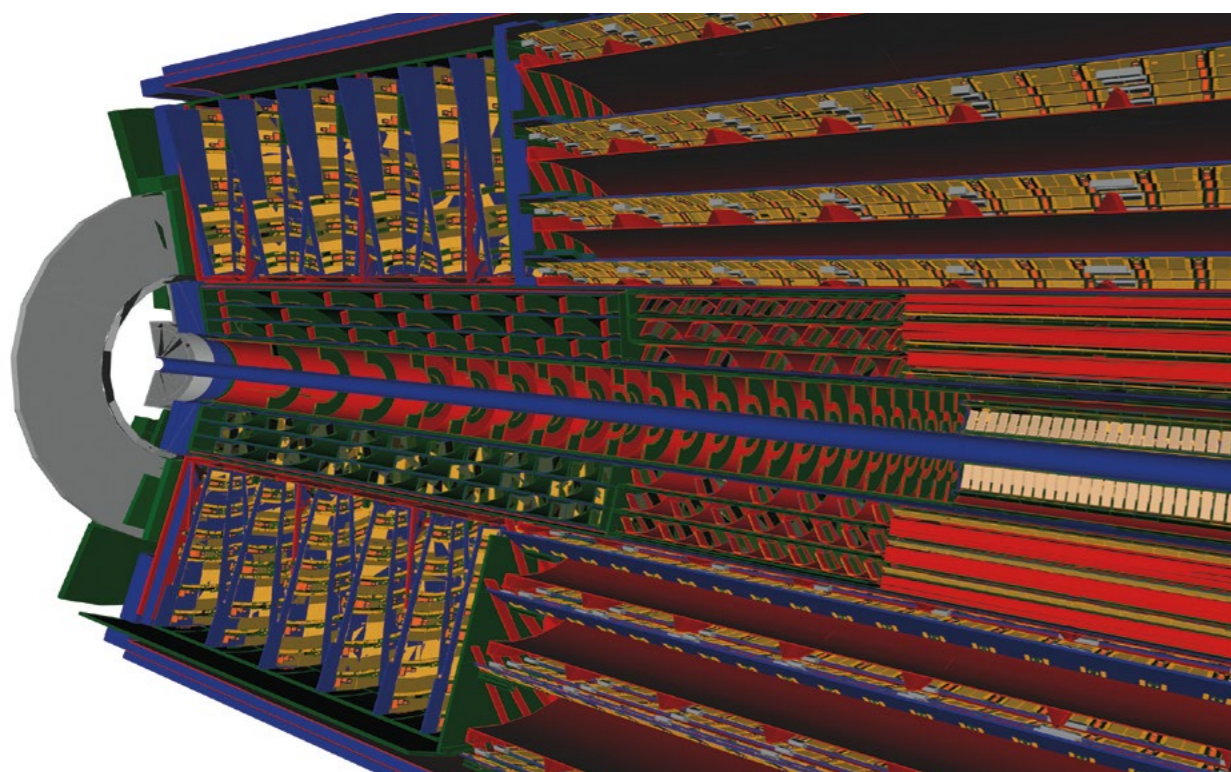

Pixel perfection The ATLAS ITk, comprising strip (outer layers) and pixel (inner layers) detectors with more than five billion readout channels.

The discovery of the Higgs boson at the LHC in 2012 changed the landscape of high-energy physics forever. After just a few short years of data-taking by the ATLAS and CMS experiments, this last piece of the Standard Model (SM) was proven to exist. Since then, the Higgs sector has been studied using a rapidly growing dataset and, so far, all measurements agree with the SM predictions within the experimental uncertainties. In parallel, a comprehensive programme of searches for beyond-SM processes has been carried out, resulting in strong constraints on new physics. A harvest of precise measurements of a large variety of processes, confronted with state-of-the-art theoretical predictions, has further supported the SM. However, the theory lacks explana-

tions for, among others, the nature of dark matter, the cosmological baryon asymmetry and neutrino masses. Importantly, the Higgs sector is related to “naturalness” problems that suggest the existence of new physics at the TeV scale, which the LHC can probe (CERN Courier July/August 2022 p47).

The high-luminosity phase of the LHC (HL-LHC) will provide an order of magnitude more data starting from 2029, allowing precision tests of the properties of the Higgs boson and improved sensitivity to a wealth of new-physics scenarios. The HL-LHC will deliver to each of the ATLAS and CMS experiments approximately 170 million Higgs bosons and 120,000 Higgs-boson pairs over a period of about 10 years. By extrapolating Run 2 results to the HL-LHC dataset, this

THE AUTHORS

Stefan Guindon
CERN,
Christian Ohm
KTH Stockholm
and Caterina
Vernieri SLAC.

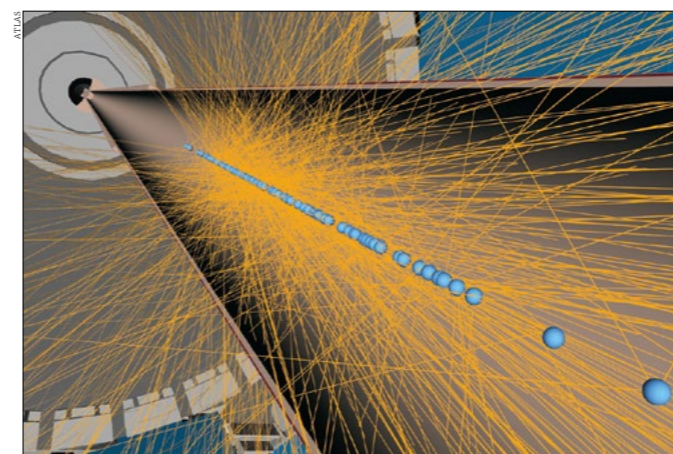

Pileup A simulated $t\bar{t}$ event in a proton-proton collision at 14 TeV at the HL-LHC, including approximately 200 pileup interactions in the same bunch crossing. No fewer than 88 primary vertices (blue balls) are reconstructed along the beam line, each producing many particles (orange tracks). In total, more than 2000 tracks are reconstructed in the proton-proton interaction.

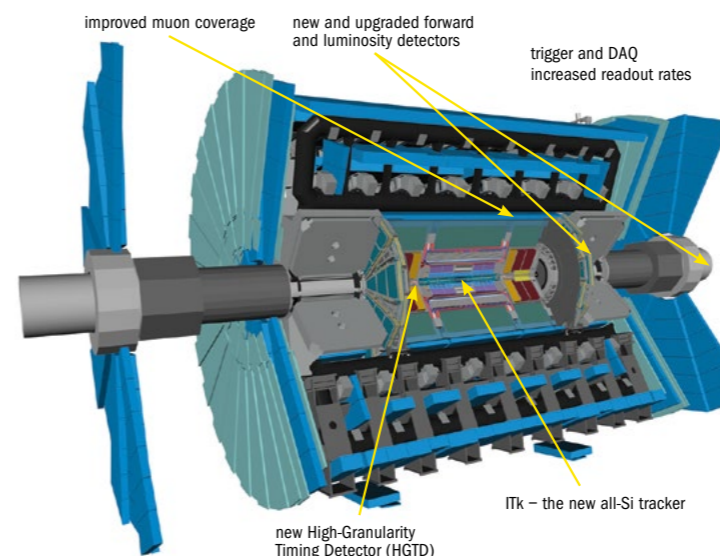

ATLAS Phase II Schematic of the major upgrades to the ATLAS detector for the HL-LHC era. (Credit: ATLAS)

will increase the precision of most Higgs-boson coupling measurements: 2–4% precision on the couplings to W, Z and third-generation fermions; and approximately 50% precision on the self-coupling by combining the ATLAS and CMS datasets. The larger dataset will also give improved sensitivity to rare vector-boson scattering processes that will offer further insights into the Higgs sector.

These precision measurements could reveal discrepancies with the SM predictions, which in turn could inform us about the energy scale of beyond-SM physics. In addition to improving SM measurements, the upgraded detectors and

trigger systems being developed and constructed for the HL-LHC era will enable direct searches to better target new physics with challenging signatures. To achieve these goals, it will be essential to achieve a detailed understanding of the detector performance as well as to measure the integrated luminosity of the collected dataset to 1% precision.

Rising to the challenge

To cope with the increased number of interactions when proton bunches collide at the HL-LHC, the ATLAS collaboration is working hard to upgrade its detectors with state-of-the-art instrumentation and technologies. These new detectors will need to cope with challenging radiation levels, higher data rates and an extreme high-occupancy environment with up to 200 proton-proton interactions per bunch crossing (see “Pileup” figure). Upgrades will include changes to the trigger and data-acquisition systems, a completely new inner tracker, as well as a new silicon timing detector (see “ATLAS Phase II” figure).

The trigger and data-acquisition system will need to cope with a readout rate of 1 MHz, which is about 10 times higher than today. To achieve this, ATLAS will use a new architecture with a level-0 trigger (the first-level hardware trigger) based on the calorimeter and muon systems. Building on the upgrades for Run 3, which started in July 2022, the calorimeter will include capabilities for triggering at higher pseudorapidity, up to $|\eta| = 4$. During HL-LHC running, the global trigger system will be required to handle 50 Tb/s as input and to decide within 10 μ s whether each event should be recorded or discarded, allowing for more sophisticated algorithms to be run online for particle identification. All the detectors will require substantial upgrades to handle the additional acceptance rates from the trigger.

The readout electronics for the electromagnetic, forward and hadronic end-cap liquid-argon calorimeters, along with the hadronic tile calorimeter, will be replaced. The full calorimeter systems, segmented into 192,320 cells that are read out individually, will be read out for every bunch crossing at the full 40 MHz to provide full-granularity information to the trigger. This will require changes to both front-end electronics and off-detector components.

The muon system will also see significant upgrades to the on-detector electronics of the resistive plate chambers (RPCs) and thin-gap chambers (TGCs) responsible for triggering on muons, as well as the muon drift tubes (MDTs) responsible for measuring the curvature of the tracks precisely. The MDTs will also be used for the first time in the level-0 trigger decisions. These improvements will allow all data to be sent to the back-end at 40 MHz, removing the need for readout buffers on the detector itself. All hits in the detector will be used to perform trigger logic in hardware using field programmable gate-arrays. Additional improvements to increase the trigger acceptance for muons will come in the form of a new layer of RPCs to be installed in the inner barrel layer, along with new MDTs in the small sectors. The Muon New Small Wheel system was installed during Long Shutdown 2 (LS2) from 2019 to 2022 (CERN Courier November/December 2021 p27) and is located inside the end-cap toroid magnet containing both triggering and precision tracking chambers. Additional

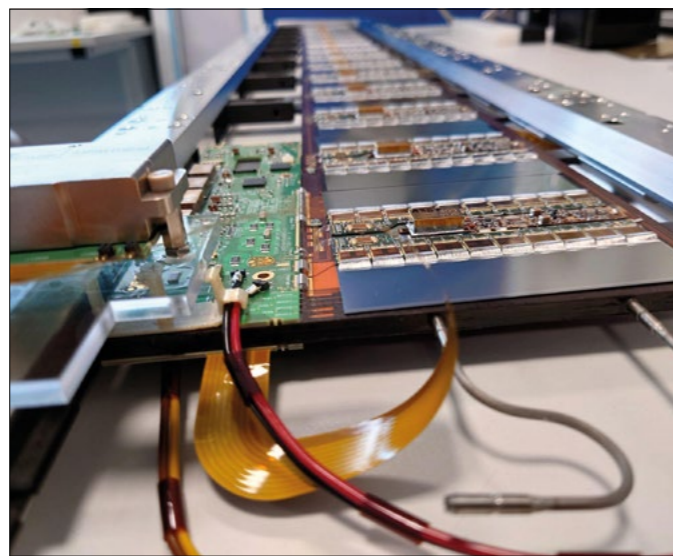

ITk prototyping Loaded prototypes for (left) a pixel end-cap ring of the inner system and (right) a strip barrel stave of the ITk detector.

RPC upgrades were also made in the barrel leading up to Run 3, and the TGCs will be upgraded in the endcap region of the muon system during LS3.

State-of-the-art tracking

The success of the research programme at the HL-LHC will strongly rely on the tracking performance, which in turn determines the ability to efficiently identify hadrons containing b and c quarks, in addition to tau and other charged leptons. Reconstructing individual particles in the HL-LHC collision environment with thousands of charged particles being produced within a region of about 10 cm will be very challenging. The entire tracking system, presently consisting of pixel and strip detectors and the transition radiation tracker, will be replaced by a new all-silicon pixel and strip tracker – the ITk. This will feature higher granularity, increased radiation hardness and readout electronics that allow higher data rates and a longer trigger latency. The new pixel detector will also extend the pseudorapidity coverage in the forward region from $|\eta| < 2.5$ to $|\eta| < 4$, increasing the acceptance for important physics processes like vector-boson fusion (see “Pixel perfection” image, p22).

The ITk will comprise nine barrel layers, positioned at radii from 33mm out to 1m from the beam line, plus end-cap rings. It will be much more complex with respect to the present ATLAS tracker, featuring 10 times the number of strip channels and 60 times the number of pixel channels. The strip detectors will cover a total surface of 160 m² with 60 million readout channels, and the pixels an area of 13 m² with more than five billion readout channels. The innermost layer will be populated with radiation-hard 3D sensors, with pixel cells of 25 × 100 μm² in the barrel part and 50 × 50 μm² in the forward parts for improved tracking capabilities in the central and forward regions. Prototypes of the end-cap ring for the inner system and

To cope with the increased number of interactions when proton bunches collide at the HL-LHC, the ATLAS collaboration is working hard to upgrade its detectors with state-of-the-art instrumentation and technologies

of the strip barrel stave are at an advanced stage (see “ITk prototyping” image). A unique feature of the trackers at the HL-LHC is that they will be operated for the first time with a serial powering scheme, in which a chain of modules is powered by a constant current. If the modules were to be powered in parallel, the high total current would lead to either high power losses or a large mass of cables within the volume of the detector, which would impact the tracking performance.

Given the challenging conditions posed by the HL-LHC, ATLAS will construct a novel precision-timing silicon detector, the High-Granularity Timing Detector (HGTD), which provides a time resolution of 30 to 50 ps for charged particles. The detector will cover a pseudorapidity range of $2.4 < |\eta| < 4$ and will comprise two double-sided silicon layers on each side of ATLAS with a total active area of 6.4 m². The precise timing information will allow the collaboration to disentangle proton-proton interactions in the same bunch crossing in the time dimension, complementing the impressive spatial resolution of the ITk. Low-gain avalanche diodes (see “Clocking tracks” image) provide timing information that can be associated with tracks in the forward regions, where they are more difficult to assign to individual interactions using spatial informa-

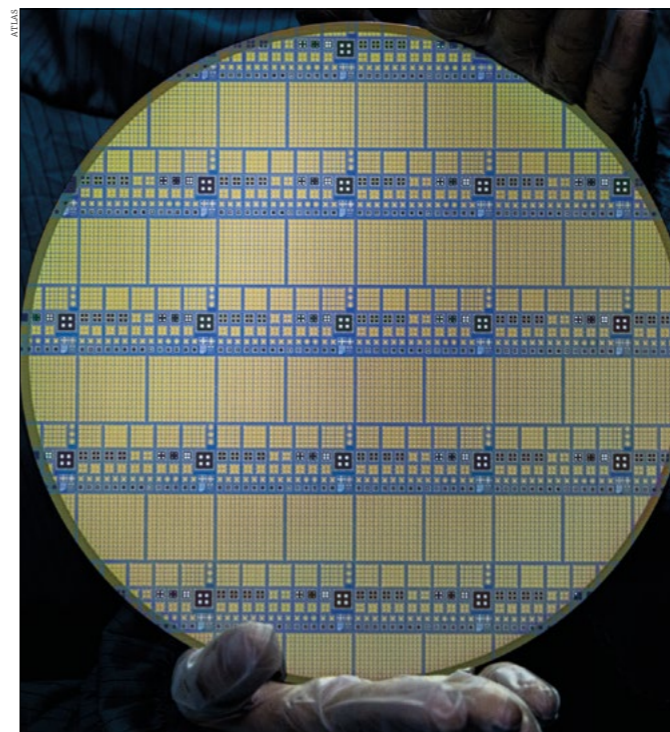

Clocking tracks An 8-inch prototype wafer of low-gain avalanche diodes for the High Granularity Timing Detector.

tion. With a timing resolution six times smaller than the temporal spread of the beam spot, tracks emanating from collisions occurring very close in space but well-separated in time can be distinguished. This is particularly important in the forward region, where reduced longitudinal impact-parameter resolution limits the performance.

Building upon the insertable B-layer cooling system used since the start of Run 2, and to reduce the material budget, ATLAS will use a two-phase CO₂ cooling system for the entire silicon ITk and HGTD detectors. These will allow the detectors to be cooled to around -35 °C during the entire lifetime of the HL-LHC. The low temperature is required to protect the silicon sensors from the expected high radiation dose received during their lifetime. Two-phase CO₂ cooling is an environmentally friendly option compared to other suitable coolants. It provides a high heat transfer at reasonable flow parameters, a low viscosity (thus reducing the material used in the detector construction) and a well-suited temperature range for detector operations.

Luminous future

Precise knowledge of the luminosity is key for the ATLAS physics programme. To reach the goal of percent-level precision at the HL-LHC, ATLAS will upgrade the LUCID (Luminosity Cherenkov Integrating Detector) detector, a luminometer that is sensitive to charged particles produced at the interaction point. This is incredibly challenging given

the number of interactions expected to be delivered by the machine, and the requirements on radiation hardness and long-term stability for the lifetime of the experiment. The HGTD will also provide online luminosity measurements on a bunch-by-bunch basis, and additional detector prototypes are being tested to provide the best possible precision for luminosity determination during HL-LHC running. Luminometers in ATLAS provide luminosity monitoring to the LHC every one to two seconds, which is required for efficient beam steering, machine optimisation and fast checking of running conditions. In the forward region, the zero-degree calorimeter, which is particularly important for determining the centrality in heavy-ion collisions, is also being redesigned for HL-LHC running.

The HL-LHC will deliver luminosities of up to $7.5 \times 10^{34} \text{ cm}^{-2} \text{ s}^{-1}$, and ATLAS will record data at a rate 10 times higher than in Run 2. The ability to process and analyse these data depends heavily on R&D in software and computing, to make use of resource-efficient storage solutions and opportunities that paradigm-shifting improvements like heterogeneous computing, hardware accelerators and artificial intelligence can bring. This is needed to simulate and process the high-occupancy HL-LHC events, but also to provide a better theoretical description of the kinematics.

New era

The Phase-II upgrade projects described are only possible through collaborative efforts between universities and laboratories across the world. The research teams are currently working intensely to finalise the designs, establish the assembly and testing procedures, and in some cases start construction. They will all be installed and commissioned during LS3 in time for the start of Run 4, currently planned for 2029.

The HL-LHC will provide an order of magnitude more data recorded with a dramatically improved ATLAS detector. It will usher in a new era of precision tests of the SM, and of the Higgs sector in particular, while also enhancing sensitivity to rare processes and beyond-SM signatures. The HL-LHC physics programme relies on the successful and timely completion of the ambitious detector upgrade projects, pioneering full-scale systems with state-of-the-art detector technologies. If nature is harboring physics beyond the SM at the TeV scale, then the HL-LHC will provide the chance to find it in the coming decades. ●

Further reading

ATLAS Collab. 2012 CERN-LHCC-2012-022.
 ATLAS Collab. 2015 CERN-LHCC-2015-020.
 ATLAS Collab. 2017 CERN-LHCC-2017-005.
 ATLAS Collab. 2017 CERN-LHCC-2017-018.
 ATLAS Collab. 2017 CERN-LHCC-2017-019.
 ATLAS Collab. 2017 CERN-LHCC-2017-017.
 ATLAS Collab. 2017 CERN-LHCC-2017-020.
 ATLAS Collab. 2020 CERN-LHCC-2020-007.
 ATLAS Collab. 2020 CERN-LHCC-2020-015.
 ATLAS Collab. 2022 CERN-LHCC-2022-004.
 ATLAS and CMS Collabs. 2022 ATL-PHYS-PUB-2022-018.

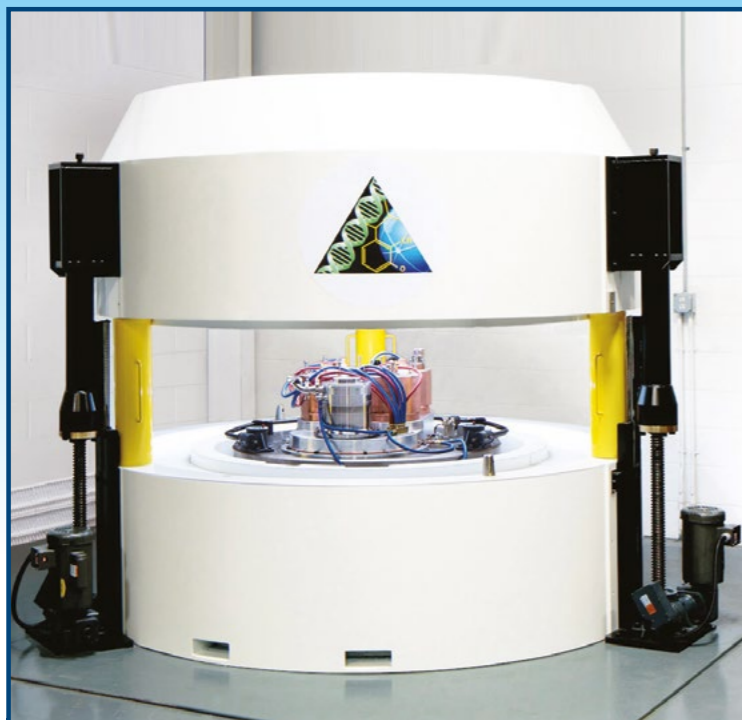

NEW! Best 6–15 MeV Compact High Current/ Variable Energy Proton Cyclotron

- 1–1000 μA extracted beam current
- Capable of producing the following isotopes: ^{18}F , ^{68}Ga , ^{89}Zr , $^{99\text{m}}\text{Tc}$, ^{11}C , ^{13}N , ^{15}O , ^{64}Cu , ^{67}Ga , ^{111}In , ^{124}I , ^{225}Ac , ^{103}Pd and more!
- Up to 5×10^{13} neutrons per second from external target
- 21 stripping foils at each stripping port for 2 minute rapid change



**Some of the products shown are under development and not available for sale currently.*

NEW! Best Model 200 Sub-Compact Self-Shielded Cyclotron with Optional Second Chemistry Module

- Low energy compact system, can be placed next to PET/CT
- Easy to operate push-button graphic interface
- Automated quality control testing
- Ideal for Nuclear Cardiology/Oncology and other Applications
- Capable of producing: ^{18}FDG , Na^{18}F , $^{18}\text{F-MISO}$, ^{18}FLT , $^{18}\text{F-Choline}$, $^{18}\text{F-DOPA}$, $^{18}\text{F-PSMA}$, ^{11}C , ^{13}N , ^{68}Ga and more!



NEW! Best Model B35adp Alpha/ Deuteron/Proton Cyclotron for Medical Radioisotope Production and Other Applications

- Proton Particle Beam: 1000 μA Beam Current up to 35 MeV Energy
- Deuteron Particle Beam: 500 μA Beam Current up to 15 MeV Energy
- Alpha Particle Beam: 200 μA Beam Current up to 35 MeV Energy



Assembly of Best 35 MeV Cyclotron at the Best Theratronics facility in Ottawa, Ontario, CN.

Best 70 MeV Cyclotron Ideal for Sr-82/Rb-82 Supply and Research

- 70–35 MeV variable energy H^- cyclotron
- 700 μA extracted beam current (upgradable to 1000 μA)
- 2 simultaneous extracted beams
- Multiple independent beam lines and target positions



Installation of Best 70 MeV Cyclotron at INFN, Legnaro, Italy.

NEW! Best Model 180p Cyclotron for Proton Therapy (Patent Pending)

- From 70 MeV up to 180 MeV Non-Variable Energy
- Dedicated for Proton Therapy with two beam lines and two treatment rooms
- For all Medical Treatments including: Benign and Malignant Tumors, Neurological, Eye, Head/Neck, Pediatric, Lung Cancers, Vascular/Cardiac/Stenosis/Ablation, etc.

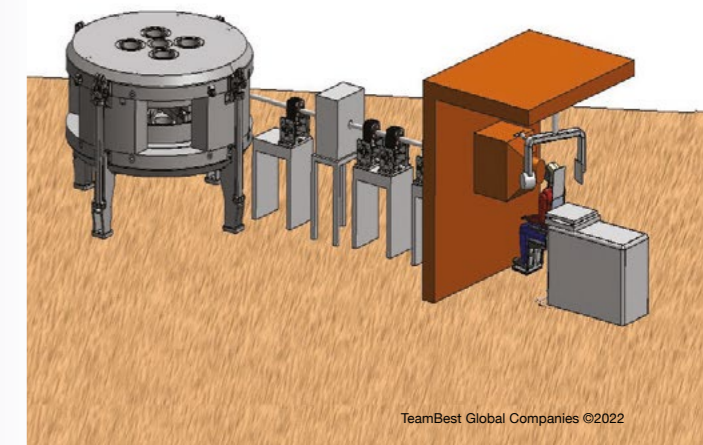

TeamBest Global Companies ©2022

Best Medical International 7643 Fullerton Road, Springfield, VA 22153 tel: 703 451 2378

AFRICA | ASIA | EUROPE | LATIN AMERICA | MIDDLE EAST | NORTH AMERICA

www.bestcyclotron.com • www.bestproton.com • www.teambest.com

BCS USA tel: 865 982 0098 • BCS CAN tel: 604 681 3327 • BPT tel: 703 451 2378

FROM DREAMS TO BEAMS

SESAME'S 30 YEAR-LONG JOURNEY IN SCIENCE DIPLOMACY

Scientists in the Middle East broke ground for the SESAME light source in January 2003. Founder Eliezer Rabinovici describes the story behind this beacon for peaceful international collaboration, what its achievements have been, and what the future holds.

SESAME (Synchrotron-light for Experimental Science and Applications in the Middle East) is the Middle East's first major international research centre. It is a regional third-generation synchrotron X-ray source situated in Allan, Jordan, which broke ground on 6 January 2003 and officially opened on 16 May 2017. The current members of SESAME are Cyprus, Egypt, Iran, Israel, Jordan, Pakistan, Palestine and Turkey. Active current observers include, among others: the European Union, France, Germany, Greece, Italy, Japan, Kuwait, Portugal, Spain, Sweden, Switzerland, the UK and the US. The common vision driving SESAME is the belief that human beings can work together for a cause that furthers the interests of their own nations and that of humanity as a whole.

The story of SESAME started at CERN 30 years ago. One day in 1993, shortly after the signature of the Oslo Accords by Israel and the Palestine Liberation Organization, the late Sergio Fubini, an outstanding scientist and a close friend and collaborator, approached me in the corridor of the CERN theory group. He told me that now was the time to test what he called "your idealism", referring to future joint Arab-Israeli scientific projects.

CERN is a very appropriate venue for the inception of such a project. It was built after World War II to help heal Europe and European science in particular. Abdus Salam, as far back as the 1950s, identified the light source as a tool that could help thrust what were then considered "third-world" countries directly to the forefront of scientific research. The very same Salam joined our efforts in 1993 as a member of the Middle Eastern Science Committee (MESOC), founded by Sergio, myself and many others to forge meaningful scientific contacts in the region. By joining our scientific committee, Salam made public his belief in the value of Arab-Israeli scientific collaborations, something the Nobel laureate had expressed several times in private.

To focus our vision, that year I gave a talk on the status of Arab-Israeli collaborations at a meeting in Torino held on the occasion of Sergio's 65th birthday. Afterwards we travelled to Cairo to meet Venice Gouda, the Egyptian minister for higher education, and other Egyptian officials. At that stage we were just self-appointed entrepreneurs. We were told that president Hosni Mubarak had made a decision to take politics out of scientific collaborations with Israel, so together we organized a high-quality scientific meeting in Dahab, in the Sinai desert. The meeting, held in a large Bedouin tent on 19–26 November 1995, brought together about 100 young and senior scientists from the region and



Illuminating The SESAME booster (inner ring) and storage ring, concealed behind their concrete shielding.



Thumbs up Participants of the SESAME users' meeting outside the main building in December 2017.

beyond. It took place in the weeks after the murder of the Israeli prime minister Yitzhak Rabin, for whom, at the request of Venice Gouda, all of us stood for a moment of silence in respect. The silence echoes in my ears to this day. The first day of the meeting was attended by Jacob Ziv, president of the Israeli Academy of Sciences and Humanities, which had been supporting such efforts in general. It was thanks to the

additional financial help of Miguel Virasoro, director-general of ICTP at the time, and also Daniele Amati, director of SISSA, that the meeting was held. All three decisions of support were made at watershed moments and on the spur of the moment. The meeting was followed by a very successful effort to identify concrete projects in which Arab-Israeli collaboration could be beneficial to both sides.

But attempts to continue the project were blocked by a turn for the worse in the political situation. MESOC decided to retreat to Torino, where, during a meeting in November 1996, there was a session devoted to studying the possibilities of cooperation via experimental activities in high-energy physics and light-source science. During that session, the late German scientist Gus Voss suggested (on behalf of himself and Hermann Winnick from SLAC) to bring the parts of a German light source situated in Berlin, called BESSY, which was about to be dismantled, to the Middle East. Former Director-General of CERN Herwig Schopper also attended the workshop. MESOC had built sufficient trust among the parties to provide an appropriate infrastructure to turn such an idea into something concrete.

Targeting excellent science

A light source was very attractive thanks to the rich diversity of fields that can make use of such a facility, from biology through chemistry, physics and many more to archaeology and environmental sciences. Such a diversity would also allow the formation of a critical mass of real users in the region. The major drawback of the BESSY-based proposal was that there was no way a reconstructed dismantled "old" machine would be able to attract first-class scientists and science.

Around that time, Fubini asked Schopper, who had a rich experience in managing complex experimental projects, to take a leadership position. The focus of possible collaborations was narrowed down to the construction of a large light source, and it was decided to use the German machine as a nucleus around which to build the administrative structure of the project. The non-relations among several of the members presented a serious challenge. At the suggestion of Schopper, following the example of the way CERN was assembled in the 1950s, the impasse was overcome by using the auspices of UNESCO to deposit the instruments for joining the project. The statutes of SESAME were to a large extent copied from those of CERN. A band of self-appointed entrepreneurs had evolved into a self-declared interim Council of SESAME, with Schopper as its president. The next major challenge was to choose a site.

On 15 March 2000 I flew to Amman for a meeting on the subject. I met Khaled Toukan (the current director-general of SESAME) and, after studying a map sold at the hotel

The non-relations among several of the members presented a serious challenge

THE AUTHOR

Eliezer Rabinovici
Hebrew University,
Jerusalem;
president of the
CERN Council and
twice-elected vice-
president of the
SESAME Council.

FEATURE SESAME LIGHT SOURCE

FEATURE SESAME LIGHT SOURCE

**Beginnings**

Above left: the setting for the November 1995 meeting in Dahab, Egypt. Above right: the SESAME groundbreaking ceremony on 6 January 2003, attended by King Abdullah II of Jordan (third from right).

where we met, we discussed which site Israel would support. We also asked that a Palestinian be the director general. Due to various developments, none of which depended on Israel, this was not to happen. The decision on the site venue was taken at a meeting at CERN on 11 April 2000. Jordan, which had and has diplomatic relations with all the parties involved, was selected as the host state. BESSY was dismantled by Russian scientists, placed in boxes and shipped with assembly instructions to the Jordanian desert to be kept until the appropriate moment would arise. This was made possible thanks to a direct contribution by Koichiro Matsuura, director-general of UNESCO at the time, and to the efforts of Khaled Toukan who has served in several ministerial capacities in Jordan.

With the administrative structure in place, it was time to address the engineering and scientific aspects of the project. Technical committees had designed a totally new machine, with BESSY serving as a boosting component. Many scientists in the region were introduced via workshops to the scientific possibilities that SESAME could offer. Scientific committees considered appropriate “day-one” beamlines, yet that day seemed very far in the future. Technical and scientific directors from abroad helped define the parameters of a new machine and identified appropriate beamlines to be constructed. Administrators and civil servants from the members started meeting regularly in the finance committee. Jordan began to build the facility to host the light source and made major additional financial contributions.

Transformative agreements

At this stage it was time for the SESAME interim council to transform into a permanent body and in the process cut its umbilical cord from UNESCO. This transformation presented new hurdles because it was required of every member that wished to become a member of the permanent council that its head of state, or someone authorised by the head of state, sign an official document sent to UNESCO stating this wish.

By 2008 the host building had been constructed. But it remained essentially empty. SESAME had received support from leading light-source labs all over the world – a spiritual source of strength to members to continue with the project. However, attempts to get significant funding failed time and again. It was agreed that the running costs of the

project should be borne by the members, but the one-time large cost needed to construct a new machine was outside the budget parameters of most of the members, many of whom did not have a tradition of significant support for basic science. The European Union (EU) supported us in that stage only through its bilateral agreement with Jordan. In the end, several million Euros from those projects did find their way to SESAME, but the coffers of SESAME and its infrastructure remained skeletal.

Changing perceptions

In 2008 Herwig Schopper was succeeded by Chris Llewellyn Smith, another former Director-General of CERN, as president of the SESAME Council. His main challenge was to get the funding needed to construct a new light source and to remove from SESAME the perception that it was simply a reassembled old light source of little potential attraction to top scientists. In addition to searching for sources of significant financial support, there was an enormous amount of work still to be done in formulating detailed and realistic plans for the following years. A grinding systematic effort began to endow SESAME with the structure needed for a modern working accelerator, and to create associated information materials.

Llewellyn Smith, like his predecessor, also needed to deal with political issues. For the most part the meetings of the SESAME Council were totally devoid of politics. In fact, they felt to me like a parallel universe where administrators and scientists from the region get to work together in a common project, each bringing her or his own scars and prejudices and each willing to learn. That said, there were moments when politics did contaminate the spirit forming in SESAME. In some cases, this was isolated and removed from the agenda and in others a bitter taste remains. But these are just at the very margins of the main thrust of SESAME.

The empty SESAME building started to be filled with radiation shields, giving the appearance of a full building. But the absence of the light-source itself created a void. The morale of the local staff was in steady decline, and it seemed to me that the project was in some danger. I decided to approach the ministry of finance in Israel. When I asked if Israel would make a voluntary contribution to SESAME of \$5 million, I was not shown the door. Instead they requested to come and see SESAME, after which they

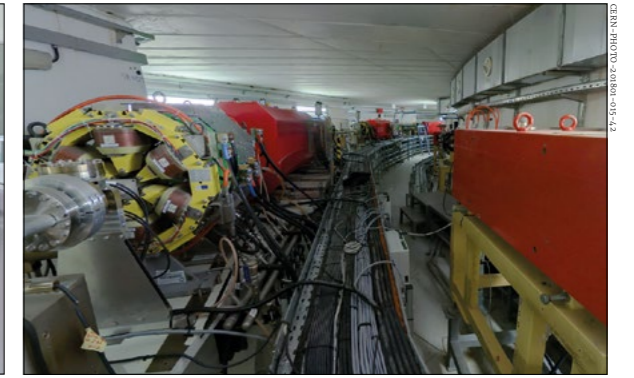

discussed the proposal with Israel’s budget and planning committee and agreed to contribute the requested funds on the condition that others join them.

Each member of the unlikely coalition – consisting of Iran, Israel, Jordan and Turkey – pledged an extra \$5 million for the project in an agreement signed in Amman. Since then, Israel, Jordan and Turkey have stood up to their commitment, and Iran claims that it recognises its commitment but is obstructed by sanctions. The support from members encouraged the EU to dedicate \$5 million to the project, in addition to the approximately \$3 million directed earlier from a bilateral EU–Jordan agreement. In 2015 the INFN, under director Fernando Ferroni, gave almost \$2 million. This made it possible to build a hostel, as offered by most light sources, which was named appropriately after Sergio Fubini. Many leading world labs, in a heartwarming expression of support, have donated equipment for future beam lines as well as fellowships for the training of young people.

Point of no return

With their help, SESAME crossed the point of no return. The undefined stuff dreams are made of turned into magnets and girdles made of real hard steel, which I was able to touch as they were being assembled at CERN. The pace of events had finally accelerated, and a star-studded inauguration including attendance by the king of Jordan took place on 16 May 2017. During the ceremony, amazingly, the political delegates of different member states listened to each other without leaving the room (as is the standard practice in other international organisations). Even more unique was that each member-state delegate taking the podium gave essentially the same speech: “We are trying here to achieve understanding via collaboration.”

At that moment the SESAME Council presidency passed from Chris Llewellyn Smith to a third former CERN Director-General, Rolf Heuer. The high-quality 2.5 GeV electron storage ring at the heart of SESAME started operation later that year, driving two X-ray beamlines: one dedicated to X-ray absorption fine structure/X-ray fluorescence (XAFS/XRF) spectroscopy, and another to infrared spectro-microscopy. A third powder-diffraction beamline is presently being added, while a soft X-ray beamline “HESEB” designed and constructed by five

Helmholtz research centres is being commissioned. In 2023 the BEAmline for Tomography at SESAME (BEATS) will also be completed, with the construction and commissioning of a beamline for hard X-ray full-field tomography.

The unique SESAME facility started operating with uncanny normality. Well over 100 proposals for experiments were submitted and refereed, and beam time was allocated to the chosen experiments. Data was gathered, analysed and the results were and are being published in first-rate journals. Given the richness of archaeological and cultural heritage in the region, SESAME’s beamlines offer a highly versatile tool for researchers, conservators and cultural-heritage specialists to work together on common projects. The first SESAME Cultural Heritage Day took place online on 16 February 2022 with more than 240 registrants in 39 countries (CERN Courier July/August 2022 p19).

Thanks to the help of the EU, SESAME has also become the world’s first “green” light source, its energy entirely generated by solar power, which also has the bonus of stabilising the energy bill of the machine. There is, however, concern that the only component used from BESSY, the “Microtron” radio-frequency system, may eventually break down, thus endangering the operation of the whole machine.

SESAME continues to operate on a shoe-string budget. The current approved 2022 budget is about \$5.3 million, much smaller than that of any modern light source. I marvel at the ingenuity of the SESAME staff allowing the facility to operate, and am sad to sense indifference to the budget among many of the parties involved. The world’s media has been less indifferent: the BBC, *The New York Times*, *Le Monde*, *The Washington Post*, Brussels Libre, *The Arab Weekly*, as well as regional newspapers and TV stations, have all covered various aspects of SESAME. In 2019 the AAAS highlighted the significance of SESAME by awarding five of its founders (Chris Llewellyn Smith, Eliezer Rabinovici, Zehra Sayers, Herwig Schopper and Khaled Toukan) with its 2019 Award for Science Diplomacy.

SESAME was inspired by CERN, yet it was a much more challenging task to construct. CERN was built after the Second World War was over, and it was clear who had won and who had lost. In the Middle East the conflicts are not over, and there are different narratives on who is winning and who is losing, as well as what win or lose means. For

In the ring

Above left (from left to right): Master’s students Man Irmak Karakaya and Işıl Uzunok from Turkey with XAFS XRF beamline scientist Messaoud Harfouche. Above right: magnets being installed in the SESAME storage ring in 2018.

FEATURE SESAME LIGHT SOURCE

Sustainable science

SESAME is the first accelerator facility to be powered by renewable energy, which is supplied by a dedicated solar power plant located 30 km away.



CERN COURIER.COM

CERN it took less than 10 years to set up the original construct; for SESAME it took about 25 years. Thus, SESAME now should be thought of as CERN was in around 1960.

On a personal note, it brings immense happiness that for the first time ever, Israeli scientists have carried out high-quality research at a facility established on the soil of an Arab country, Jordan. Many in the region and beyond have taken their people to a place their governments most likely never dreamt of or planned to reach. It is impossible to give due credit to the many people without whom SESAME would not be the success it is today.

In many ways SESAME is a very special child of CERN, and often our children can teach us important lessons. As president of the CERN Council, I can say that the way in which the member states of SESAME conducted themselves during the decades of storms that affect our region serves

as a benchmark for how to keep bridges for understanding under the most trying of circumstances. The SESAME spirit has so far been a lighthouse even to the CERN Council, in particular in light of the invasion of Ukraine (an associate member state of CERN) by the Russian Federation. Maintaining this attitude in a stormy political environment is very difficult.

However SESAME's story ends, we have proved that the people of the Middle East have within them the capability to work together for a common cause. Thus, the very process of building SESAME has become a beacon of hope to many in our region. The responsibility of SESAME in the next years is to match this achievement with high-quality scientific research, but it requires appropriate funding and help. SESAME is continuing very successfully with its mission to train hundreds of engineers and scientists in the region. Requests for beam time continue to rise, as do the number of publications in top journals.

If one wants to embark on a scientific project to promote peaceful understanding, SESAME offers at least three important lessons: it should be one to which every country can contribute, learn and profit significantly from; its science should be of the highest quality; and it requires an unbounded optimism and an infinite amount of enthusiasm. My dream is that in the not-so-distant future, people will be able to point to a significant discovery and say "this happened at SESAME". ●

SUPERCON, Inc.

Superconducting Wire Products

Standard and Speciality designs are available to meet your most demanding superconductor requirements.

SUPERCON, Inc. has been producing niobium-based superconducting wires and cables for 58 years. We are the original SUPERCON – the world's first commercial producer of niobium-alloy based wire and cable for superconducting applications.

Standard SC Wire Types

- NbTi Wires
- Nb₃Sn – Bronze
- Nb₃Sn – Internal Tin
- CuNi resistive matrix wires
- Fine diameter SC Wires
- Aluminum clad wire
- Wire-in-Channel
- Innovative composite wires

Product Applications

- Magnetic Resonance Imaging
- Nuclear Magnetic Resonance
- High Energy Physics
- SC Magnetic Energy Storage
- Medical Therapeutic Devices
- Superconducting Magnets and Coils
- Crystal Growth Magnets
- Scientific Projects

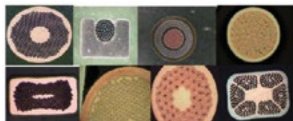

"We deliver when you need us!"

www.SUPERCON-WIRE.com

FEATURE CMS

CMS PREPARES FOR PHASE II

Novel and established detectors that push technologies to new heights will allow the CMS collaboration to fully exploit the HL-LHC physics potential. Anne Dabrowski, Frank Hartmann and Paolo Rumerio give a snapshot of the Phase II upgrade progress.

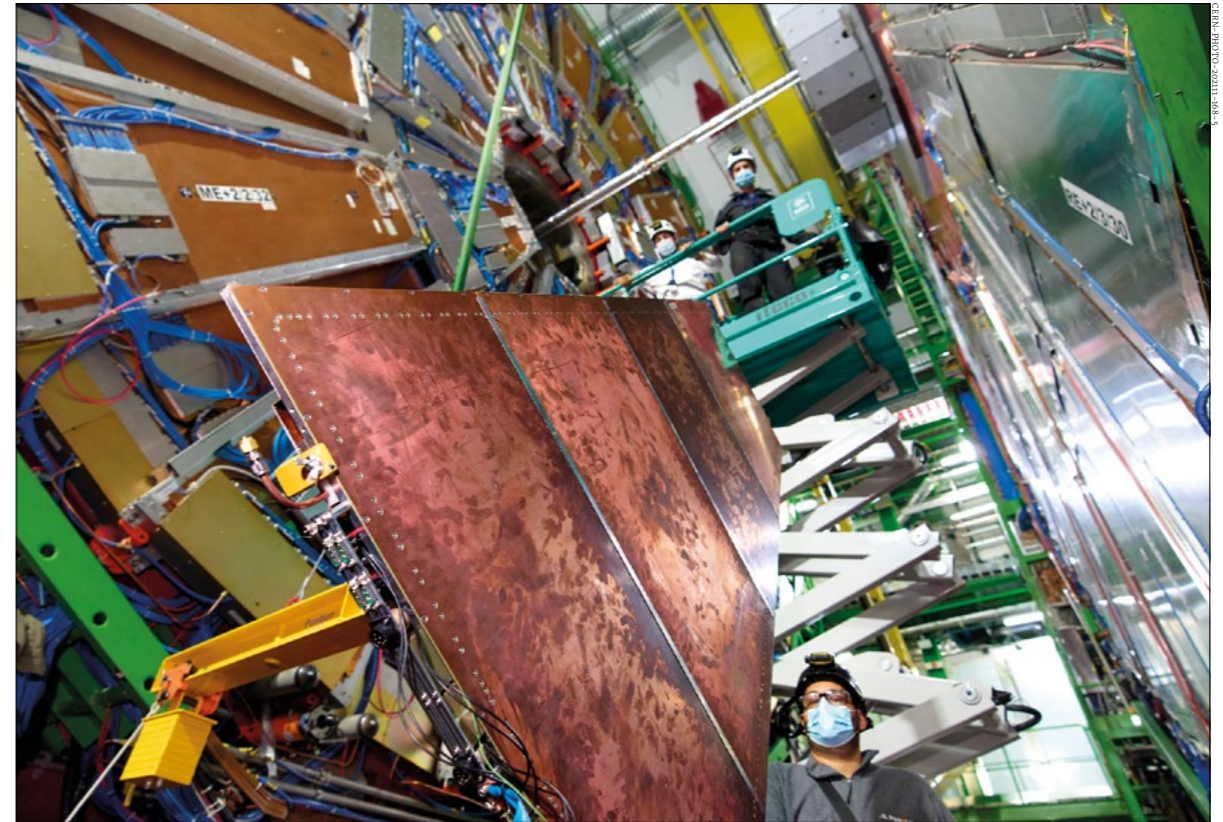

GEM of a detector The installation of a prototype GEM (gas electron multiplier) forward-muon detector in 2021.

The High-Luminosity LHC (HL-LHC), due to start operations in 2029, will deliver about 10 times more data than has been accumulated during the previous LHC runs. The CMS collaboration is getting ready to profit from sub-percent precision on many Standard Model (SM) processes and to probe physics beyond the SM, both directly and through studies of higher-order effective operators. Studying rare processes, such as double-Higgs production, rare tau-lepton decays and

Higgs couplings to second-generation fermions, will also be a central part of the programme. New ideas will certainly lead to improvements beyond the statistical scaling of uncertainties, bringing us closer to observing these rare processes. While high-precision tests of the SM will surely be the ultimate legacy of the LHC experiments, CMS will also keep searching for clear signs of new physics by investigating the many signatures accessible at the HL-LHC.

THE AUTHORS

Anne Dabrowski
CERN, Frank Hartmann
Karlsruhe Institute of Technology and Paolo Rumerio
University of Alabama and Università di Torino.



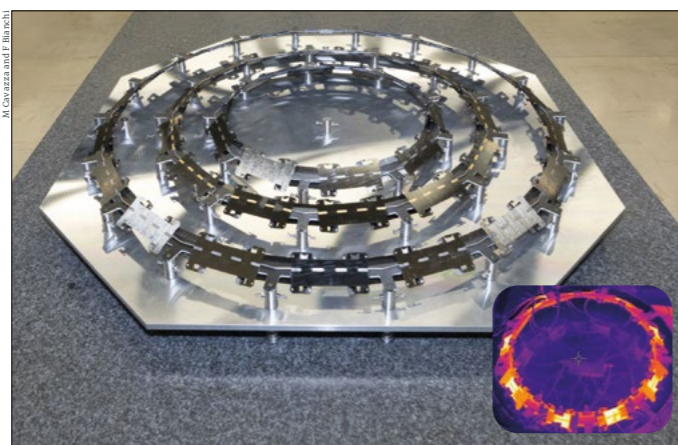
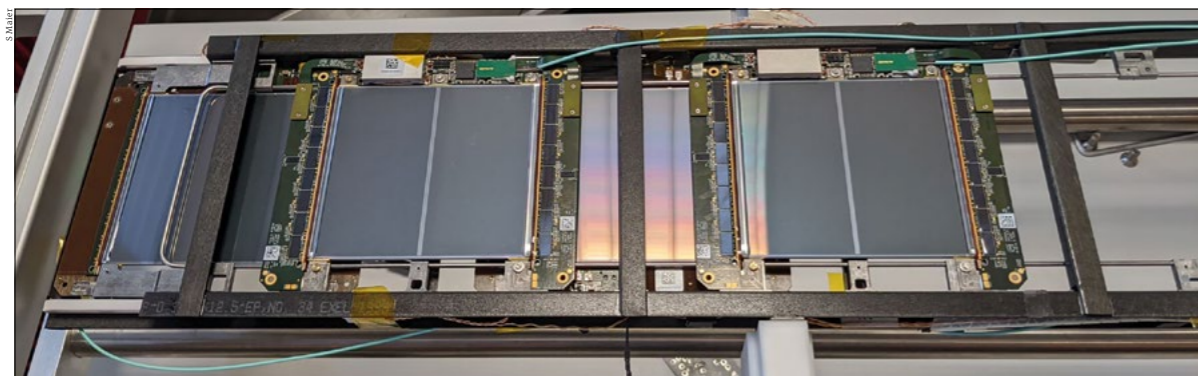

Outer tracker Top: an outer tracker barrel ladder with modules equipped with strips running up to the middle of the sensors and read-out at both ends. Left: a 12-inch 65 nm-technology wafer used as the basis of the read-out of the outer tracker, which joins a total of 25 m² of ASICs and sensors by bump-bonding. Right: a final mechanical ring design depicting the concept of tilting modules towards the interaction point, with thermal performance (inset) verified to be excellent.

To exploit the HL-LHC physics potential, the CMS collaboration is building an optimised detector that pushes technologies to new heights. This major “Phase II” upgrade will enable the subdetectors to sustain the increased luminosity, which results in greater radiation damage and higher particle rates – the innermost pixel layer, for example, will see three billion hits per second per square centimetre. The CMS tracker and the calorimeter endcap will be replaced, a new minimum-ionising-particle precision timing detector (MTD) and a new luminosity detector will be installed, almost all of the existing electronics will be replaced, and additional muon forward stations will be mounted.

High granularity

The key to achieving the necessary HL-LHC performance is to enhance the granularity of the detector significantly. This reduces the maximum occupancy per readout cell while considerably increasing the readout bandwidth and processing power of the trigger system, thereby fully exploiting the higher collision rates. As a novelty, all CMS detector designs are tuned to allow full particle-flow

reconstruction at the hardware-based level-1 trigger (operating at 40 MHz), while precision timing information, which contributes to the high-level-trigger decision, is exploited by highly optimised software mostly running on graphics processing units.

CMS is currently transitioning from the prototyping to the production phase on several major items. The novel gas electron multiplier (GEM) detector concept, used to detect muons produced in the very forward region, was deployed for the first time on a large scale during long shutdown 2 (LS2): 144 chambers in the first station are fully integrated into the ongoing data taking and the second station will be fully installed in a year-end technical stop before LS3 (see “GEM of a detector” image). Finishing endcap-muon upgrades in advance of LS3 allows the collaboration to minimise the repositioning of the CMS disks during LS3 and to reduce its overall duration. In this spirit, CMS has already finished the replacement of all front-end electronics of the cathode strip chambers. The replacement of the drift-tube electronics in the barrel muon detectors will take place in LS3, and an installed small-scale drift-tube



High-granularity calorimetry Left: a cooling plate in the hadronic section, providing the base for the hexagonal silicon modules (to left of plate) and the rectangular SiPM-on-tiles (right). Right: automated high-granularity calorimeter silicon-module assembly, showing the gantry joining the hexagonal 8-inch pad sensor with glue circles to the read-out board electronics.

The high-granularity calorimeter in the forward region starts a new era of calorimetry

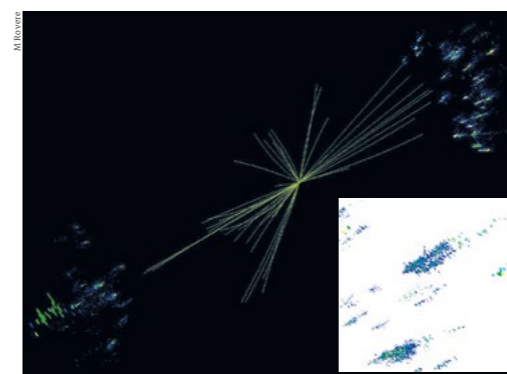

HGCAL on display The high-granularity calorimeter will allow particles to be traced fully throughout the detector, including the real shower shape (inset).

come most engineering and prototyping challenges. ASICs (application-specific integrated circuits) and sensors are being delivered and the order for the hybrids (which host integrated circuits and connections in the front-end modules) has been submitted. The inner tracker (pixel system) will feature two billion micro-pixels, compared to the 125 million at present. Four barrel layers plus 12 disks per endcap enable excellent track seeding and b-quark jet identification over the pseudorapidity range $|\eta| < 4$ (much broader than today’s $|\eta| < 2.5$). The inner tracker system aspects are understood, sensors will be ordered soon, and teams are waiting for the final readout ASIC to begin module production.

A new era of calorimetry

The high-granularity calorimeter (HGAL) in the forward region starts a new era of calorimetry. It is a radiation-tolerant 5D imaging calorimeter with spatial, energy and precision-timing information (see “HGAL on display” and “High-granularity calorimetry” images). The deployment of machine-learning algorithms will further enhance its potential to establish the HGAL as a blueprint for future calorimeters. The HGAL has 6.4 million channels, two orders of magnitude more than the current endcap calorimeters, including both silicon cells (with an area of 0.5 or 1 cm²) and scintillator tiles (4 to 32 cm²) read out by silicon photomultipliers (SiPMs). The electromagnetic section consists of 26 active layers of silicon sensors interleaved with copper, copper-tungsten and lead absorbers. It is followed by the hadronic section, which is made of 21 active layers of silicon and scintillator tiles, separated by steel absorbers. All in all, 600 m² are equipped with silicon sensors (three times the area of the tracker) and 400 m² with SiPMs-on-tiles.

The hexagonal-shaped sensors and the modules mimicking bee-hive structures are a design feature of the HGAL. The hexagonal structure makes optimal use of the circular silicon wafer, therefore being cost-effective. With the sensor design and evaluation completed, mass production has started. The development of silicon sensors that are sufficiently radiation-tolerant for HL-LHC

demonstrator is already proving its performance.

The exceptional performance of the current all-silicon tracker provides a solid platform for even further improvements. A main novelty for Phase II is the level-1 track trigger, which reconstructs tracks with transverse momentum above 2 GeV, made available at a rate of 40 MHz. Profiting from the experience with pixels from Phase I, the whole Phase II tracker will use dual-phase CO₂ cooling, ultra-lightweight mechanics, DCDC converters for the powering of the outer tracker, and serial powering for the pixel system, thereby reducing the amount of material by a factor of two compared to today. To reduce the occupancies expected at the highest foreseeable number of collisions per bunch crossing (pile-up), the outer-tracker channel count will increase from 9 million strips to 42 million strips plus 170 million macro-pixels, providing unambiguous z-position measurements. With six barrel layers and five double-disks per endcap, the outer tracker is optimised not only for standalone tracking but also for vertexing, a prerequisite for the track trigger (see “Outer tracker” image).

The outer tracker is already in production, having over-

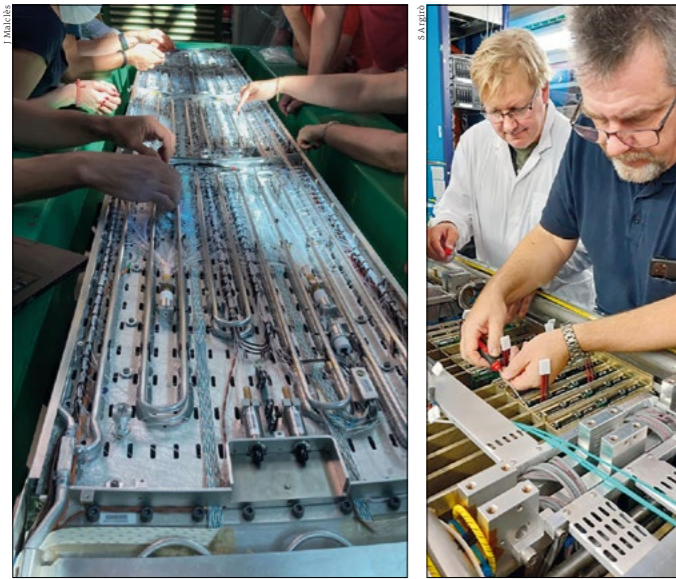

ECAL upgrades A barrel electromagnetic calorimeter spare supermodule being refurbished with upgraded readout electronics and used for vertical integration tests.

conditions, for both the HGAL and the tracker, has taken considerable effort. It is also worth noting the use, for the first time in particle physics, of passive sensors processed on 8-inch wafers – another essential feature for covering larger areas at an affordable cost.

The electromagnetic calorimeter (ECAL) barrel and its 61,200 lead-tungstate crystals, which were instrumental in the discovery of the Higgs boson via its decay to two photons, will be retained and equipped with new front-end electronics capable of sustaining the higher rates and trigger latency (see “ECAL upgrades” image). Faster signal processing will result in a much-improved time resolution of 30 ps for high-energy photons (and electrons), enabling precise primary-vertex determination.

The novel track trigger and the much-improved cell granularity allow the full implementation of the particle-flow reconstruction (based on field-programmable gate arrays, FPGAs) already in the level-1 trigger. The single-crystal granularity that will be provided by the ECAL barrel, even at the trigger level, together with the 3D imaging features of the HGAL, provide crucial information to precisely follow the path of all particles through the entire detector. This opens the possibility of establishing a full menu of cross-particle triggers and of using FPGA-based machine learning at the level-1 trigger. Trigger algorithms have been prototyped in FPGAs and demonstrated in a multi-board “slice test”. In order to efficiently process the 63 Tb/s input bandwidth, the system is equipped with 250 FPGAs, with an output rate of 750 kHz and a latency of 12.5 μ s.

Bright times ahead

For the luminosity measurement, CMS is following a strategy analogous to the one for the trigger, exploiting data from various subdetectors with the ambitious goal of 1%

offline (2% online) uncertainty. Achieving this precision requires an understanding of the detector systematic effects, such as linearity and stability, at the per-mille level. A dedicated silicon-pad-based luminometer with an asynchronous readout will help in quantifying systematic uncertainties and beam-related backgrounds, and will play an essential role in the CMS (and LHC accelerator) commissioning.

CMS will enter further uncharted territory in the precision-timing domain with the MTD. For the barrel system, the challenge is to adapt the cost-effective LYSO crystal + SiPM technology, similar to that used in PET scanners, to sustain the HL-LHC rates and radiation. An interesting detail is the use of micro-Peltier elements (thermo-electric coolers) to further decrease the local temperature on the SiPMs, thus counteracting the effects of radiation damage. The endcaps use a new twist on well-established silicon tracking technology: low-gain avalanche detectors, with an additional thin implant within the sensor to generate internal gain. The MTD covers the full solid angle up to $|\eta| = 3$ to mitigate pile-up, boost the sensitivity to searches for long-lived particles, and enhance the physics capabilities during heavy-ion runs by providing particle identification capability via time-of-flight measurements.

All these individual systems are combined into the CMS Phase II detector. Technical coordination is choreographing the integration and has established a detailed schedule for LS3, taking all the detector and external requirements and constraints into account. To maximise the time for detector installation and commissioning during LS3, a huge effort is ongoing in preparing the site in advance. New buildings are already under construction to house the new service infrastructure, such as chillers for the detector CO₂ cooling, uninterrupted power systems and detector- and dry-gas systems. During LS3, the biggest challenge will be to decommission all the legacy systems, including services, that will be replaced by new detectors, and then fit all the new pieces together.

The CMS Phase-II upgrade is a multi-faceted project involving more than 2000 scientists, students and engineers from institutes and industrial companies in more than 50 countries. Initially discussed prior to the first LHC operation and defined by the CMS technical proposal in 2015, the CMS Phase II upgrade together with upgrades to the other LHC detectors will ensure that maximal physics is extracted under the challenging conditions of the HL-LHC. ●

Further reading

CMS Collab. 2015 CERN-LHCC-2015-10.
 CMS Collab. 2017 CERN-LHCC-2017-009.
 CMS Collab. 2017 CERN-LHCC-2017-011.
 CMS Collab. 2017 CERN-LHCC-2017-012.
 CMS Collab. 2017 CERN-LHCC-2017-023.
 CMS Collab. 2019 CERN-LHCC-2019-003.
 CMS Collab. 2020 CERN-LHCC-2020-004.
 CMS Collab. 2021 CERN-LHCC-2021-007.
 CMS Collab. 2021 CERN-LHCC-2021-008.

A THEORY OF THEORIES

Effective field theory (EFT) is now seen as the most fundamental and generic way to capture the physics of nature at all scales, with applications ranging from LHC physics to cosmology. Michèle Levi takes a tour through the past, present and future of EFT.

High-energy physics spans a wide range of energies, from a few MeV to TeV, that are all relevant. It is therefore often difficult to take all phenomena into account at the same time. Effective field theories (EFTs) are designed to break down this range of scales into smaller segments so that physicists can work in the relevant range. Theorists “cut” their theory’s energy scale at the order of the mass of the lightest particle omitted from the theory, such as the proton mass. Thus, multi-scale problems reduce to separate and single-scale problems (see “Scales” image, p38). EFTs are today also understood to be “bottom-up” theories. Built only out of the general field content and symmetries at the relevant scales, they allow us to test hypotheses efficiently and to select the most promising ones without needing to know the underlying theories in full detail. Thanks to their applicability to all generic classical and quantum field theories, the sheer variety of EFT applications is striking.

In hindsight, particle physicists were working with EFTs from as early as Fermi’s phenomenological picture of beta decay in which a four-fermion vertex replaces the W-boson propagator because the momentum is much smaller compared to the mass of the W boson (see “Fermi theory” image, p38). Like so many profound concepts in theoretical physics, EFT was first considered in a narrow phenomenological context. One of the earliest instances was in the 1960s, when ad-hoc methods of current algebras were utilised to study weak interactions of hadrons. This required detailed calculations, and a simpler approach was needed to derive useful results. The heuristic idea of describing hadron dynamics with the most general Lagrangian density based on symmetries, the relevant energy scale and the relevant particles, which can be written in terms of operators multiplied by Wilson coefficients, was yet to be known. With this approach, it was possible to encode local symmetries in terms of the current algebra due to their association with conserved currents.

For strong interactions, physicists described the interaction between pions with chiral perturbation theory, an effective Lagrangian, which simplified current algebra

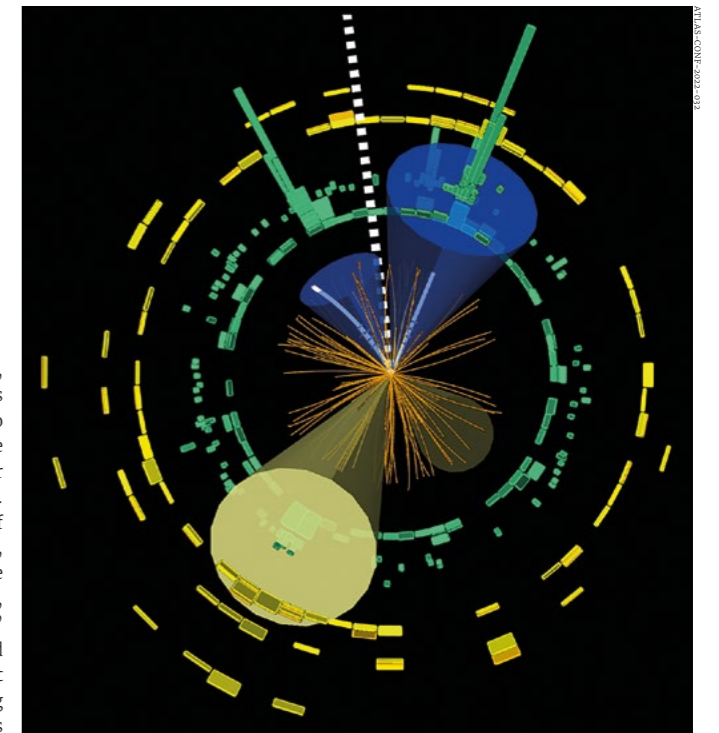

LHC physics Effective field theory enables a deeper understanding of complex physics processes at the LHC, such as the above production of Higgs bosons in ATLAS.

calculations and enabled the low-energy theory to be investigated systematically. This “mother” of modern EFTs describes the physics of hadrons and remains valid to an energy scale of the proton mass. Heavy-quark effective theory (HQET), introduced by Howard Georgi in 1990, complements chiral perturbation theory by describing the interactions of charm and bottom quarks. HQET allowed us to make predictions on B-meson decay rates, since the corrections could now be classified. The more powers of energy are allowed, the more infinities appear. These infinities are cancelled by available counter-terms.

Similarly, it is possible to regard the Standard Model as the truncation of a much more general theory including non-renormalisable interactions, which yield corrections of higher order in energy. This perception of the whole Standard Model as an effective field theory started to be formed in the late 1970s by Weinberg and others (see “All things EFT: a lecture series hosted at CERN” panel). Among the known corrections to the Standard Model that do not satisfy its approximate symmetries are neutrino masses, postulated in the 1960s and discovered via the observation of neutrino oscillations in the late 1990s. While the scope

THE AUTHOR
 Michèle Levi
 University of Oxford.

FEATURE EFFECTIVE FIELD THEORY

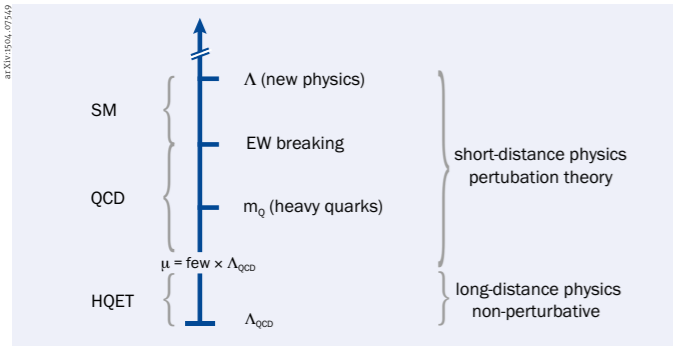

Scales Different energy scales require different effective field theories, such as HQET, which describes the interactions of charm and bottom quarks. HQET remains valid until the scale $\mu = \text{few}$ times the cut-off scale Λ_{QCD} , which is of the order of the proton mass.

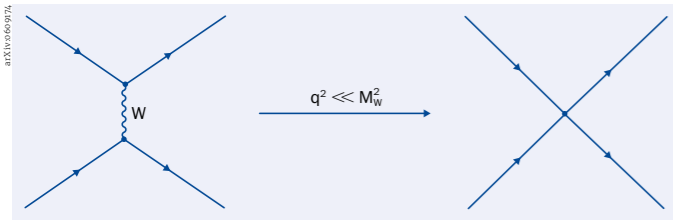

Fermi theory Before anyone thought of EFTs or knew the full electroweak interaction, the Fermi theory was introduced to describe beta decay. In this effective field theory, the four-fermion vertex (right) replaces the W-boson propagator (left) because the momentum q^2 is much smaller than the W-boson mass.



Next generation EFTs will be critical in interpreting data from existing ground-based gravitational-wave detectors, such as KAGRA (top), and future ones, such as the Einstein Telescope (above, artistic impression).

of EFTs was unclear initially, today we understand that all successful field theories, with which we have been working in many areas of theoretical physics, are nothing but effective field theories. EFTs provide the theoretical framework to probe new physics and to establish precision programmes at experiments. The former is crucial for making accurate theoretical predictions, while the latter is central to the physics programme of CERN in general.

EFTs in particle physics

More than a decade has passed since the first run of the LHC, in which the Higgs boson and the mechanism for electroweak symmetry breaking were discovered. So far, there are no signals of new physics beyond the SM. EFTs are well suited to explore LHC physics in depth. A typical example for an event involving two scales is Higgs-boson production because there is a factor 10–100 between its mass and transverse momentum. The calculation of each Higgs-boson production process leads to large logarithms that can invalidate perturbation theory due to the large-scale separation. This is just one of many examples of the two-scale problem that arises when the full quantum field theory approach for high-energy colliders is applied. Traditionally, such two-scale problems have been treated in the framework of QCD factorisation and resummation.

Over the past two decades, it has been possible to recast two-scale problems at high-energy colliders with the advent of soft-collinear effective theory (SCET). SCET is

nowadays a popular framework that is used to describe Higgs physics, jets and their substructure, as well as more formal problems, such as power corrections to reconstruct full amplitudes eventually. The difference between HQET and SCET is that SCET considers long-distance interactions between quarks and both soft and collinear particles, whereas HQET takes into account only soft interactions between a heavy quark and a parton. SCET is just one example where the EFT methodology has been indispensable, even though the underlying theory at much higher energies is known. Other examples of EFT applications include precision measurements of rare decays that can be described by QCD with its approximate chiral symmetry, or heavy quarks at finite temperature and density. EFT is also central to a deeper understanding of the so-called flavour anomalies, enabling comparisons between theory and experiment in terms of particular Wilson coefficients.

Moreover, precision measurements of Higgs and electroweak observables at the LHC and future colliders will provide opportunities to detect new physics signals, such as resonances in invariant mass plots, or small deviations from the SM, seen in tails of distributions for instance at the HL-LHC – testing the perception of the SM as a low-energy incarnation of a more fundamental theory being probed at the electroweak scale. This is dubbed the SMEFT (SM EFT) or HEFT (Higgs EFT), depending on whether the Higgs fields are expressed in terms of the Higgs doublet or the physical

FEATURE EFFECTIVE FIELD THEORY

All things EFT: a lecture series hosted at CERN

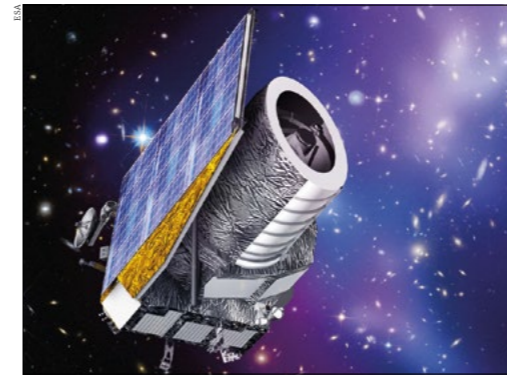

Expanding horizons Artist's impression of the Euclid satellite, the science programme of which relies heavily on EFT.

Higgs boson. This particular EFT framework has recently been implemented in the data-analysis tools at the LHC, enabling the analyses across different channels and even different experiments (see “LHC physics” image, p37). At the same time, the study of SMEFT and HEFT has sparked a plethora of theoretical investigations that have uncovered its remarkable underlying features, for example allowing EFT to be extended or placing constraints on the EFT coefficients due to Lorentz invariance, causality and analyticity.

EFTs in gravity

Since the inception of EFT, it was believed that the framework is applicable only to the description of quantum field theories for capturing the physics of elementary particles at high-energy scales, or alternatively at very small length scales. Thus, EFT seemed mostly irrelevant regarding gravitation, for which we are still lacking a full theory valid at quantum scales. The only way in which EFT seemed to be pertinent for gravitation was to think of general relativity as a first approximation to an EFT description of quantum gravity, which indeed provided a new EFT perspective at the time. However, in the past decade it has become widely acknowledged that EFT provides a powerful framework to capture gravitation occurring completely across large length scales, as long as these scales display a clear hierarchy.

The most notable application to such classical gravitational systems came when it was realised that the EFT framework would be ideal to handle gravitational radiation emitted at the inspiral phase of a binary of compact objects, such as black holes. At this phase in the evolution of the binary, the compact objects are moving at non-relativistic velocities. Using the small velocity as the expansion parameter exhibits the separation between the various characteristic length scales of the system. Thus, the physics can be treated perturbatively. For example, it was found that even couplings manifestly change in classical systems across their characteristic scales, which was previously believed to be unique to quantum field theories. The application of EFT to the binary inspiral problem has been so successful that the precision frontier has been pushed beyond the state of the art, quickly surpassing the reach of work that has been focused on the two-body problem

A novel global lecture series titled “All things EFT” was launched at CERN in autumn 2020 as a cross-cutting online series focused on the universal concept of EFT, and its application to the many areas where it is now used as a core tool in theoretical physics. Inaugurated in a formidable historical lecture by the late Steven Weinberg, who reviewed the emergence and development of the idea of EFT through to its perception nowadays as encompassing all of quantum field theory and beyond, the lecture series has amassed a large following that is still growing. The series featured outstanding speakers, world-leading experts from cosmology to fluid dynamics, condensed-matter physics, classical and quantum gravity, string theory, and of course particle physics – the birthing bed of the powerful EFT framework. The second year of the series was kicked off



Pioneer Without Weinberg's insights, EFT would not be the powerful framework that it is.

in a lecture dedicated to the memory of Weinberg by Howard Georgi, who looked back on the development of heavy-quark effective theory and its immediate aftermath.

for decades via traditional methods in general relativity.

This theoretical progress has made an even broader impact since the breakthrough direct discovery of gravitational waves (GWs) was announced in 2016. An inspiraling binary of black holes merged into a single black hole in less than a split second, releasing an enormous amount of energy in the form of GWs, which instigated even greater, more intense use of EFTs for the generation of theoretical GW data. In the coming years and decades, a continuous increase in the quantity and quality of real-world GW data is expected from the rapidly growing worldwide network of ground-based GW detectors, and future space-based interferometers, covering a wide range of target frequencies (see “Next generation” image, p38).

EFTs in cosmology

Cosmology is inherently a cross-cutting domain, spanning scales over about 10^{60} orders of magnitude, from the Planck scale to the size of the observable universe. As such, cosmology generally cannot be expected to be tackled directly by each of the fundamental theories that capture particle physics or gravity. The correct description of cosmology relies heavily on the work in many disparate areas of research in theoretical and experimental physics, including particle physics and general relativity among many more.

The development of EFT applications in cosmology – including EFTs of inflation, dark matter, dark energy and even EFTs of large-scale structure – has become essential to make observable predictions in cosmology. The discovery of the accelerated expansion of the universe in 1998 shows our difficulty in understanding gravity both at the quantum regime and the classical one. The cosmological

EFTs provide the theoretical framework to probe new physics and to establish precision programmes at experiments across all domains of physics

constant problem and dark-matter paradigm might be a hint for alternative theories of gravity at very large scales. Indeed, the problems with gravity in the very-high and very-low energy range may well be tied together. The science programme of next-generation large surveys, such as ESA's Euclid satellite (see "Expanding horizons" image, p39), rely heavily on all these EFT applications for the exploitation of the enormous data that is going to be collected to constrain unknown cosmological parameters, thus helping to pinpoint viable theories.

The future of EFTs in physics

The EFT framework plays a key role at the exciting and rich interface between theory and experiment in particle physics, gravity and cosmology as well as in other domains, such as condensed-matter physics, which were not covered here. The technology for precision measurements in these domains is constantly being upgraded, and in the coming years and decades we are heading towards a growing influx of real-world data of higher quality. Future particle-collider projects, such as the Future Circular Collider at CERN, or China's Circular Electron Positron Collider, are being planned and developed. Precision cosmology is also thriving, with an upcoming next-generation of very large surveys, such as the ground-based LSST, or space-based Euclid. GW detectors keep improving and multiplying, and besides those that are

currently operating many more are planned, aimed at measuring various frequency ranges, which will enable a richer array of sources and events to be found.

Half a century after the concept has formally emerged, effective field theory is still full of surprises. Recently, the physical space of EFTs has been studied as a fundamental entity in its own right. These studies, by numerous groups worldwide, have exposed a new hidden "totally positive" geometric structure dubbed the EFT-hedron that constrains the EFT expansion in any quantum field theory, and even string theory, from first principles, including causality, unitarity and analyticity, to be satisfied by any amplitudes of these theories. This recent formal progress reflects the ultimate leap in the perception of EFT nowadays as the most fundamental and most generic theory concept to capture the physics of nature at all scales. Clearly, in the vast array of formidable open questions in physics that still lie ahead, effective field theory is here to stay – for good. ●

Further reading

S Weinberg 2021 *Eur. Phys. J. H.* **46** 6.
S Weinberg 1979 *Physica A* **96** 327–340.
C Burgess 2015 *Lecture Notes of Les Houches* **100** 148–197.
M Levi 2020 *Rept. Prog. Phys.* **83** 075901.
I Brivio et al. 2020 *Phys. Rept.* **793** 1–98.
M Tanabashi et al. 2018 *Phys. Rev. D* **98** 030001.

OPINION VIEWPOINT

Remembering the W discovery

Former UA2 spokesperson Luigi Di Lella recalls the events leading to the discovery of the W and Z bosons at CERN 40 years ago.



Luigi Di Lella was UA2 spokesperson from 1986 to 1990.

When the W and Z bosons were predicted in the mid-to-late 1960s, their masses were not known. Experimentalists therefore had no idea what energy they needed to produce them. That changed in 1973, when Gargamelle discovered neutral-current neutrino interactions and measured the cross-section ratio between neutral- and charged-current interactions. This ratio provided the first direct determination of the weak mixing angle, which, via the electroweak theory, predicted the W-boson mass to lie between 60 and 80 GeV, and the Z mass between 75 and 95 GeV – at least twice the energy of the leading accelerators of the day.

By then, the world's first hadron collider – the Intersecting Storage Rings (ISR) at CERN – was working well. Kjell Johnsen proposed a new superconducting ISR in the same tunnel, capable of reaching 240 GeV. A study group was formed. Then, in 1976, Carlo Rubbia, David Cline and Peter McIntyre suggested adding an antiproton source to a conventional 400 GeV proton accelerator, either at Fermilab or at CERN, to transform it into a $p\bar{p}$ collider. The problem was that the antiprotons had to be accumulated and cooled if the target luminosity ($10^{29} \text{ cm}^{-2} \text{ s}^{-1}$, providing about one Z event per day) was to be reached. Two methods were proposed: stochastic cooling by Simon van der Meer at CERN and electron cooling by Gersh Budker in Novosibirsk.

Director-General John Adams wasn't too happy that as soon as the SPS had been built, physicists wanted to convert it into a $p\bar{p}$ collider

CERN Director-General John Adams wasn't too happy that as soon as the SPS had been built, physicists wanted to convert it into a $p\bar{p}$ collider. But he accepted the suggestion, and the idea of a superconducting ISR was abandoned. Following the Initial Cooling Experiment, which showed that the luminosity target was achievable with stochastic cooling, the Sp \bar{p} S was approved in May 1978 and the construction of the Antiproton Accumulator (AA) by van der Meer and collaborators began. Around that time,

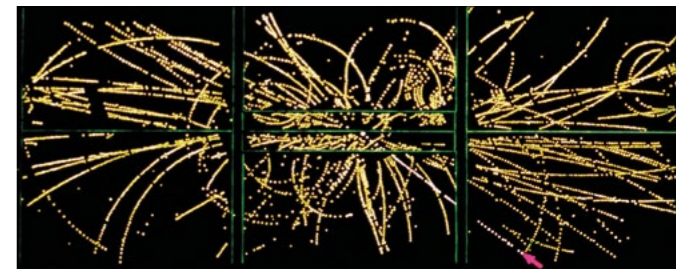

Striking A W event recorded by UA1 in late 1982, with a high transverse-momentum electron (pink arrow) and only soft particles in opposite directions to it, as expected if an undetected neutrino balances the electron's transverse momentum.

the design of the UA1 experiment was also approved.

A group of us proposed a second, simpler experiment in another interaction region (UA2), but it was put on hold for financial reasons. Then, at the end of 1978, Sam Ting proposed an experiment to go in the same place. His idea was to surround the beam with heavy material so that everything would be absorbed except for muons, making it good at identifying $Z \rightarrow \mu^+ \mu^-$ but far from good for W bosons decaying to a muon and a neutrino. In a tense atmosphere, Ting's proposal was turned down and ours was approved.

First sightings

The first low-intensity $p\bar{p}$ collisions arrived in late 1981. In December 1982 the luminosity reached a sufficient level, and by the following month UA1 had recorded six W candidates and UA2 four. The background was minimal; there was nothing else we could think of that would produce such events. Carlo presented the UA1 events and Pierre Darriulat the UA2 ones at a workshop in Rome on 12–14 January 1983. On 20 January, Carlo announced the W discovery at a CERN seminar, and the next day I presented the UA2 results, confirming UA1. In UA2 we never discussed priority, because we all knew that it was Carlo who had made the whole project possible.

The same philosophy guided the discovery of the Z boson. UA2 had recorded a candidate $Z \rightarrow e^+ e^-$ event in December 1982, also presented by Pierre at the Rome workshop. One electron was per-

fectly clear, whereas the other had produced a shower with many tracks. I had shown the event to Jack Steinberger, who strongly suggested we publish immediately; however, we decided to wait for the first "golden" event with both electrons unambiguously identified. Then, one night in May 1983, UA1 found a Z. As with ours, only one electron satisfied all electron-identification criteria, but Carlo used the event to announce a discovery. The UA1 results (based on four $Z \rightarrow e^+ e^-$ events and one $Z \rightarrow \mu^+ \mu^-$) were published that July, followed by the UA2 results (based on eight $Z \rightarrow e^+ e^-$ events, including the 1982 one) a month later.

The Sp \bar{p} S ran until 1990, when it became clear that Fermilab's Tevatron was going to put us out of business. In 1984–1985 the energy was increased from 546 to 630 GeV and in 1986 another ring was added to the AA, increasing the luminosity 10-fold. Following the 1984 Nobel prize to Rubbia and van der Meer, UA1 embarked on an ambitious new electromagnetic calorimeter that never quite worked. UA2 went on to make a precise measurement of the ratio m_W/m_Z , which, along with the first precise measurement of m_Z at LEP, enabled us to determine the W mass with 0.5% precision and, via radiative corrections, to predict the mass of the top quark (160^{+60}_{-40} GeV) several years before the Tevatron discovered it.

Times have certainly changed since then, but the powerful interplay between theory, experiment and machine builders remains essential for progress in particle physics.

cadinox®

Your Vacuum Chamber specialist

Welded solutions for complex and unique installations

www.cadinox.com



OPINION INTERVIEW

OPINION INTERVIEW

Playing in the sandbox of geometry

Number theorist and Fields medallist Maryna Viazovska talks about her research, its applications to physics and the relationship between mathematics and reality.

When did you first know you had a passion for pure mathematics?

I have had a passion for mathematics since my first year in school. At that time I did not realise what “pure mathematics” was, but maths was my favourite subject from a very early age.

What is number theory, in terms that a humble particle physicist can understand?

In fact, “number theory” is not well defined and any interesting question about numbers, geometric shapes and functions can be seen as a question for a number theorist.

What motivated you to work on sphere-packing?

I think it is a beautiful problem, something that can be easily explained. Physicists know what a Euclidean space and a sphere are, and everybody knows the problem from stacking oranges or apples. What is a bit harder to explain is that mathematicians are not trying to model a particular physical situation. Mathematicians are not bound to phenomena in nature to justify their work, they just do it. We do not need to model any physical situation, which is a luxury. The work could have an accidental application, but this is not the primary goal. Physicists, especially theorists, are used to working in multi-dimensional spaces. At the same time, these dimensions have a special interpretation in physics.

What fascinates you most about working on theoretical rather than applied mathematics?

My motivation often comes out of curiosity and my belief that the solutions to the problems will become useful at some point in the future. But it is not my job to judge



Higher spheres Ukrainian mathematician Maryna Viazovska is chair of number theory at EPFL, Lausanne, Switzerland. In 2022 she became the second woman in history to earn a Fields Medal, recognising her work on solving the sphere-packing problem.

or to define the usefulness. My belief is that the fundamental questions must be answered, so that other people can use this knowledge later. It is important to understand the phenomena in mathematics and in science in general, and the possibility of discovering something that other people have not yet. Maybe it is possible to come up with other ideas for detectors, which become interesting. When I look at physics detectors, for example, it fascinates me how complex these machines are and how many tiny technical solutions must be invented to make it all work.

How did you go about cracking the sphere-stacking problem?

I think there was an element of luck that I could find the correct idea to solve this problem because many people worked on it before. I was fortunate to find the right solution. The initial problem came from geometry, but the final solution came from Fourier analysis, via a method called linear programming.

In 2003, mathematicians Henry Cohn and Noam Elkies applied the linear programming method to the sphere-packing problem and numerically obtained a nearly optimal upper bound in dimensions 8 and 24. Their method relied on constructing

an auxiliary, “magic”, function. They computed this function numerically but could not find an explicit formula for it. My contribution was to find the explicit formula for the magic function.

What applications does your work have, for example in quantum gravity?

After I solved the sphere-packing problem in dimension 8 in 2016, CERN physicists worked on the relation between two-dimensional conformal field theory and quantum gravity. From what I understand, conformal field theories are mathematically totally different from sphere-packing problems. However, if one wants to optimise certain parameters in the conformal field theory, physicists use a method called “bootstrap”, which is similar to the linear programming that I used. The magic functions I used to solve the sphere-packing problem were independently rediscovered by Thomas Hartman, Dalimil Mazáč and Leonardo Rastelli.

Are there applications beyond physics?

One of the founders of modern computer science, Claude Shannon, realised that sphere-packing problems are not only interesting geometric problems that pure mathematicians like me can play with, but they are also a good model for error-correcting codes, which is why higher-dimensional sphere packing problems became interesting for mathematicians. A very simplified version of the original model could be the following. An error is introduced during the transmission of a message. Assuming the error is under control, the corrupted message is still close to the original message. The remedy is to select different versions of the messages called codewords, which we think are close to the original message but at the same time far away from each other, so that they do not mix with each other. In geometric language, this situation is an exact analogy of sphere-packing, where each code word represents the centre of the sphere and the sphere around

I think a mathematical reality exists on its own and sometimes it does describe actual physical phenomena

the centre represents the cloud of possible errors. The spheres will not intersect if their centres are far away from each other, which allows us to decode the corrupted message.

Do you view mathematics as a tool, or a deeper property of reality?

Maybe it is a bit idealistic, but I think a mathematical reality exists on its own and sometimes it does describe actual physical phenomena, but it still deserves our attention if not. In our mathematical world, we have chances to realise that something from this abstract mathematical world is connected to other fields, such as physics, biology or computer science. Here I think it’s good to know that the laws of this abstract world often provide us with useful gadgets, which can be used later to describe the other realities. This whole process is a kind of “spiral of knowledge” and we are in one of its turns.

Interview by **Kristiane Bernhard-Novotny** associate editor.

ANCORP

EMPOWERING SCIENCE AND TECHNOLOGY SINCE 1965
www.ancorp.com • 800-352-6431 • sales@ancorp.com

Exclusive Global Distributor of LOS Vacuum Products



ANCORP now offers LOS's full line of **UHV and XHV compatible:**

- Bimetal Flanges and Fittings
- Titanium ConFlat Flanges
- Aluminum and Titanium Custom Vacuum Chambers



Titanium and aluminum alloys allow for **quick evacuation of vacuum chambers, lower bakeout temperatures, lower magnetic permeability, and decreased outgassing rates** when compared to stainless steel.



ANCORP is a U.S. manufacturer of high and ultra-high vacuum chambers, valves, and components for research and industry. Contact us at **1-800-FLANGE1** or at **sales@ancorp.com**.



OPINION REVIEWS

A clear guide for accelerator physicists

Special Topics in Accelerator Physics

By Alexander Wu Chao

World Scientific

Special Topics in Accelerator Physics by Alexander Wu Chao introduces the global picture of accelerator physics, clearly establishing the scope of the book from the first page. The derivation and solution of concepts and equations is didactic throughout the chapters. Chao takes readers by the hand and guides them through important formulae and their limitations step-by-step, such that the reader does not miss the important parts – an extremely useful tactic for advanced masters or doctoral students when their topic of interest is among the eight special topics described.

In the first chapter, I particularly liked the way the author transitions from the Vlasov equation, a very powerful technique for studying beam-beam effects, towards the Fokker-Planck equation describing the statistical interaction of charged particles inside an accelerator. Chao pedagogically introduces the potential-well distortion, which is complemented by illustrations. The discussion on wakefield acceleration, taking readers deeper into the subject and extending it both for proton and electron beams, is timely. Extending the Fokker-Planck equation to 2D and 3D systems is particularly advanced but at the same time important. The author discusses the practical applications of the transient beam distribution in simple steps and introduces the higher order moments later. The proposed exercises, for some of which solutions are provided, are practical as well.

In chapter two, the concept of symplecticity, the conservation of phase space (a subject that causes much confusion), is discussed with concrete examples. Naming issues are meticulously explained, such as using the term short-magnet rather than thin-lens approximation in formula 2.6. Symplectic models for quadrupole magnets are introduced and the following discussion is extremely useful for students



Pedagogical Complex accelerator physics is explained in an understandable way.

and accelerator physicists who will use symplectic codes such as MAD-X and who would like to understand the mathematical framework of their operation. This nicely conjuncts with the next chapter and the book offers useful insights to how these codes operate. In the discussion about third-order integration, Chao makes occasional mental leaps, which could be mitigated with an additional sentence. Although the discussion on higher order and canonical integrators is rather specialised, it is still very useful.

The author introduces the extremely convenient and broadly used truncated power series algebra (TPSA) technique, used to obtain maps, in chapter three. Chao explains in a simple manner the transition from the pre-TPSA algorithms (such as TRANSPORT or COSY) to symplectic algorithms such as MAD-X or PTC, as well as the reason behind this evolution. The clear “drawbacks” discussion is very useful in this regard.

The transition to Lie algebra in chapter four is masterful and pedagogical. Lie algebras, which can be an advanced topic and come with many formulas, are the main focus in this section of the book. In particular, the non-linearity of the drift space, which is absent of fields, should catch the reader's attention. This is followed by specialised applications for expert readers only. One of this chapter's highlights is the derivation of the sextupole pairing, which is complemented by

that of Taylor maps up to the second order and its Lie algebra, although it would be better if the “Our plan” section was placed at the beginning of the chapter.

Chapter five covers proton-spin dynamics. Spinor formulas and the Froisart-Stora equation for the polarisation change are developed and explained. The Siberian snake technique remains one of the most well-known to retain beam polarisation, which the author discusses in detail. This links elegantly to chapter six, which introduces the reader to electron-spin dynamics where synchrotron radiation is the dominant effect and therefore constitutes a completely different research area. Chao focuses on the differences between the quantum and classical approach to synchrotron radiation, a phenomenon that cannot be ignored in high-brightness machines. Analogies between protons and electrons are then very well summarised in the recap figure 6.3. Section 6.5 is important for storage rings and leads smoothly to the Derbenev-Kondratenko formula and its applications.

Echoes

Chapter seven looks at echoes, a key technique when measuring diffusion in an accelerator, where the author introduces the reader to the generality of the term and the concept of echoes in accelerator physics. Transverse echoes (with and without diffusion) are quite analytical and the figures are didactic.

The book concludes with a very complete, concise and detailed chapter about beam-beam effects, which acts as an introduction to collider-accelerator physics for coherent- and incoherent-effects studies. Although synchro-betatron couplings causing resonant instabilities are advanced topics, they are often seen in practice when operating the machines, and the book offers the theoretical background for a deeper understanding of these effects.

Special Topics in Accelerator Physics is well written and develops the advanced subjects in a comprehensive, complete and pedagogical way.

Nikolaos Charitonidis CERN.

Frank Wilczek: 50 Years of Theoretical Physics

Edited by Antti Niemi, Kok Khoo Phua and Alfred Shapere

World Scientific



This carefully crafted edition highlights the scientific life of 2004 Nobel laureate Frank Anthony Wilczek, and the developments of theoretical physics related to his research. *Frank Wilczek: 50 Years of Theoretical Physics* is a collection of essays, original research papers and the reminiscences of Wilczek's friends, students and followers. Wilczek is an exceptional physicist with an extraordinary mathematical talent. The 23 articles represent his vivid research journey from pure particle physics to cosmology, quantum black holes, gravitation, dark matter, applications of field theory to condensed matter physics, quantum mechanics, quantum computing and beyond.

In 1973 Wilczek discovered, together with his doctoral advisor David Gross, asymptotic freedom through which the field theory of the strong interaction,

Wilczek is an exceptional physicist with an extraordinary mathematical talent

quantum chromodynamics (QCD), was firmly established. Independently that year, the same work was done by David Politzer, and all three shared the Nobel prize in 2004. Wilczek's major work includes the solution of the strong-CP problem by predicting the hypothetical axion, a result of the spontaneously broken Peccei-Quinn symmetry. In 1982 he predicted the quasiparticle “anyon”, for which evidence was found in a 2D electronic system in 2020. This satisfies the need for a new variant for 2D systems as the properties of fermions and bosons are not transferable.

Original research papers included in this book were written by pioneering scientists, such as Roman Jackiw and Edward

Witten, who are either co-inventors or followers of Wilczek's work. The articles cover recent developments of QCD, quantum-Hall liquids, gravitational waves, dark energy, superfluidity, the Standard Model, symmetry breaking, quantum time-crystals, quantum gravity and more. Many colour photographs, musical tributes to anyone, memories of quantum-connection workshops and his contribution to the Tsung-Dao Lee Institute in Shanghai complement the volume. The book ends with Wilczek's publication list, which documents the most significant developments in theoretical particle physics during the past 50 years.

Though this book is not an easy read in places, and the connections between articles are not always clear, a patient and careful reader will be rewarded. The collection combines rigorous scientific discussions with an admixture of Wilczek's life, wit, scientific thoughts and teaching – a precious and timely tribute to an exceptional physicist.

Sabyasachi Sarkar Durgapur Institute of Advanced Technology and Management.

**STAY CONNECTED WITH A
UNIQUE, DIVERSE, SUPPORTIVE
AND LIKE-MINDED
COMMUNITY**

A mission of peaceful scientific fundamental research

Approachable, collaborative, with a shared experience

Multicultural, worldwide and broad trajectories

Join now!
alumni.cern

The High-Energy Network
Le Réseau des hautes énergies

PEOPLE CAREERS

Moving from big science into big tech

CERN alumni working in Google, Microsoft and other big-tech firms offer practical advice on how to get started, what errors to avoid, and how to promote your assets when seeking to move out of academia.

The latest edition of the CERN Alumni Network's "Moving out of academia" series, held on 21 October, focused on how to successfully manage a transition from academia to the big-tech industry. Six panellists who have started working in companies such as Google, Microsoft, Apple and Meta shared their advice and experience on how to successfully start a career in a large multinational company after having worked at large scale-research infrastructures such as CERN.

In addition to describing the nature of their work and the skills acquired at CERN that have helped them make the transition, the panellists explained which new skills they had to develop after CERN for a successful career move. The around 180 participants who attended the online event received tips for interviews and CV-writing and heard personal stories about how a PhD prepares you for a career outside academia.

The panellists agreed that metrics used in academia to qualify a person's success, such as a PhD, the h-index, or the number of published papers, do not necessarily apply to roles outside of academia, except for research positions. "You don't need to have a PhD or a certificate to demonstrate that you are a good problem solver or a good programmer - you should do a PhD because you are interested in the field," said Cristina Bahamonde, who used to work in accelerator operations at CERN and now oversees and unblocks all Google's network deployments as regional leader for its global network delivery team in Europe, the Middle East and Africa. She considers her project-management and communication skills, which she acquired during her time at CERN while designing solution and mitigation strategies for operational changes in the LHC, essential for her current role.

General skills needed for big-tech companies include the ability to learn and adapt fast,



New start Cristina Bahamonde used to work in accelerator operations at CERN and now is at Google.

project and product-management skills, as well as communicating effectively to technical and non-technical audiences. Some participants were unaware that skills that they sharpened intuitively throughout their academic career are vital for a career outside.

"CERN taught me how to be a generalist," says James Casey, now a group programme manager at Microsoft. "I was not working as a product manager at CERN, but you do very similar work at CERN because you write documents, build customer relationships and need to communicate your work in an understandable way as well as to communicate the work that needs to be done." At CERN in 1994, Casey worked as a summer student alongside the original team that developed the web. After having worked in start-ups, he returned to CERN for a while and then moved back to industry in 2011.

Finding the narrative

Finding your own narrative and presenting it in the right way on a resumé is not always easy. "When I write my resumé, it looks really straight forward," said Mariana Rihl, former LHCb experimentalist and now Meta's product-system validation lead for verifying and validating Oculus VR products. "But only after a certain time, I realised that a common theme emerged - testing hardware and understanding users' needs." Working on the LHCb beam-gas vertex detector and especially ensuring the function-

ality of detector hardware prepared her well, she said.

Former CERN openlab intern Ritika Kanade, who now works as a software engineer at Apple, shared her experience of interviewing people applying for software engineering roles. "What I like to see during an interview is how the applicant approaches the tasks and how he or she interacts with me. It's ok if someone needs help. That's normal in our job," she adds. "Time management is one thing I see many candidates struggle with." Other skills needed in industry as well as in academia are tenacity and persistence. Often, candidates need to apply more than three times to land a job at their favourite company. "I applied six or seven times before I was invited for an interview at Google," emphasised Bahamonde.

The Moving out of academia series provides a rich source of advice for those seeking to make a career change, with the latest event following others dedicated to careers in finance, industrial engineering, big data, entrepreneurship, the environment and medical technologies. "This CERN Alumni event demonstrated once more the impact of high-energy physics on society and that people transitioning from academia to industry bring fresh insights from another field," said Rachel Bray, head of CERN Alumni relations.

Kristiane Bernhard-Novotny associate editor.



RELIABLE UNDER ALL CONDITIONS.

Heading into the unknown to open new horizons demands reliable tools. Help turn your research goals into reality. Vacuum valve solutions and bellows from VAT provide unfailing reliability and enhanced process safety - under all conditions.



www.vatvalve.com

PEOPLE CAREERS

Appointments and awards

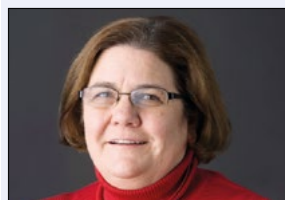

From Fermilab to the DOE
Regina Rameika (above) joined the US Department of Energy (DOE) Office of Science as associate director for the office of high energy physics on 7 November, having spent much of her career in neutrino science and experimental particle physics at Fermilab. Meanwhile, Fermilab's Marcela Carena has been announced as one of two new DOE Office of Science distinguished scientist fellows (funded by \$1 million over three years) for her leadership and influential contributions to particle physics and promoting Latin American participation in DOE-hosted experiments.

Luisella Lari joins EIC
On 3 October, Brookhaven National Laboratory named Luisella Lari as project manager for the future Electron-Ion Collider (EIC). Lari worked for nearly 12 years as a planning officer and applied physicist at



CERN before joining the European Spallation Source, where she coordinated accelerator-project budgets and ran data-driven safety analyses. Afterwards, she oversaw international partner contributions to the Proton Improvement Plan-II at Fermilab.

2023 APS awards
Announced on 11 October, the spring 2023 prizes and awards of the American Physical Society (APS) recognised several researchers in high-energy

physics and related areas. In experimental particle physics, striking at a key test of the Standard Model, William M Morse (BNL, below left) and Bradley Lee Roberts (Boston University, below right) were awarded the W K H Panofsky Prize "for their leadership and technical ingenuity in achieving a measurement of the muon anomalous magnetic moment with a precision suitable



to probe Standard Model mediated loop diagrams and possible manifestations of new physics". For theoretical achievements in high-energy physics, the JJ Sakurai Prize was awarded to Heinrich Leutwyler (University of Bern, below left) "for his work on the effective field theory of pions at low energies, and for proposing that the gluon is a colour octet". While the former was influential in chiral perturbation theory, the latter helped to establish QCD as the description of the strong interaction. Recognising outstanding experimental research in nuclear physics, the Tom W Bonner Prize went to Jen-Chieh Peng (University of Illinois Urbana-Champaign) "for his pioneering work on studying antiquark distributions in the nucleons and nuclei using the Drell-Yan process as an experimental tool, and for his work on elucidating the origins of the flavour asymmetries of light-quark sea in the nucleons". In nuclear theory, Michael Ramsey-Musolf (below right, University of Massachusetts



and Tsung-Dao Lee Institute) received the Herman Feshbach Prize for his contributions in precision electroweak studies of nuclear and hadronic systems. For outstanding contributions in gravitational-wave physics, Emanuele Berti (Johns Hopkins) was granted the Richard A Isaacson Award for his studies of black-hole quasinormal modes, higher multipole radiation, astrophysical detection rates, spin evolution, and tests of general relativity, while Gary T Horowitz (UC Santa Barbara) won the biennial Einstein Prize for fundamental contributions to classical gravity and gravitational aspects of string theory. Last but not least, the Henry Primakoff Award for Early-Career Particle Physics was given to Bernhard Mistlberger (SLAC) for his contributions to high-precision quantum field theory, including the next-to-next-to-next-to-leading order QCD corrections to the production of Higgs and electroweak vector bosons at hadron colliders.

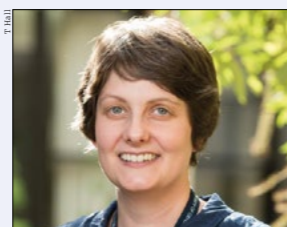

2022 IOP awards
Among the recipients of the 2022 UK Institute of Physics awards were: Philip Allport (University of Birmingham), a long-term leader of ATLAS upgrade projects, who was awarded the James Chadwick Prize for seminal contributions to radiation-hard semiconductor detector development and to the transfer of particle-physics detector technologies for use in medical applications; theoretical cosmologist Katy Clough (University of Oxford, above), who won the James Clerk Maxwell Medal for her contributions to the field of inflationary cosmology and dark-matter physics; and Kieran Flanagan (University of

Manchester), co-founder of CRIS at CERN's ISOLDE facility, who was honoured with the Ernest Rutherford Medal and Prize for his contributions to understanding properties of exotic radioactive nuclei by measuring their hyperfine structures using laser spectroscopy and trace-metal analysis.

Calaga wins for crabbing
Rama Calaga, a radio-frequency physicist in CERN's accelerator systems department and a



work-package leader of the High-Luminosity LHC project, has been awarded the 2022 US Particle Accelerator School early-career award for his outstanding leadership in bringing crab cavities in hadron colliders from concept to reality, and for the first demonstration of crabbing on a hadron beam.

Gold medal for Girone
CERN openlab CTO Maria Girone has been awarded the Gold Medal of Calabria for her contribution to particle-physics research and scientific computing. She has worked in scientific computing at CERN since 2002, contributing

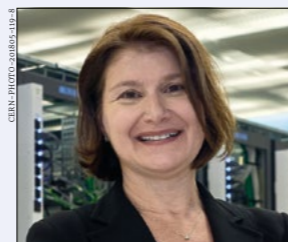

to projects such as the worldwide LHC computing grid, and was the software and computing coordinator for CMS in 2014 and 2015 before joining CERN openlab.

RECRUITMENT

For advertising enquiries, contact *CERN Courier* recruitment/classified, IOP Publishing, 2 The Distillery, Glassfields, Avon Street, Bristol BS2 0GR, UK. Tel +44 (0)117 930 1264 E-mail sales@cerncourier.com. Please contact us for information about rates, colour options, publication dates and deadlines.

Think. Innovate. Create.

At CERN physicists and engineers are using the world's largest and most complex scientific instruments to study the fundamental structure of the universe.

CERN needs more than physicists and engineers - if you're a student, a graduate or just starting your career, whatever your field and level of expertise, CERN could be your next opportunity.



Join our talent community!

Fill out a short form and we will keep you updated on our latest opportunities and news based on your interests.

careers.cern

CERN. Take Part! 



We build quantum computers.

IQM is the pan-European leader in building quantum computers. IQM provides on-premises quantum computers for supercomputing data centres and research labs, and offers full access to its hardware. For industrial customers, IQM delivers a quantum advantage through a unique application-specific, co-design approach.

IQM is building Finland's first commercial 54-qubit quantum computer with VTT, and an IQM-led consortium (Q-Exa) is also building a quantum computer in Germany. This computer will be integrated into an HPC supercomputer to create a quantum accelerator for future scientific research.

IQM has over 200+ employees with offices in Paris, Madrid, Munich, and Espoo.

WE ARE HIRING!

We are always on the lookout for awesome quantum engineers, software architects, project managers, and other skilled professionals for our offices in Finland, Germany, Spain and France. We provide relocation support.

Apply now at meetiqm.com/careers or send us an open application.

Learn more! www.meetiqm.com



[@meetiqm](https://www.meetiqm.com)

[/iqm-quantum-computers/](https://www.meetiqm.com)

[/c/IQMQuantumComputers/](https://www.meetiqm.com)

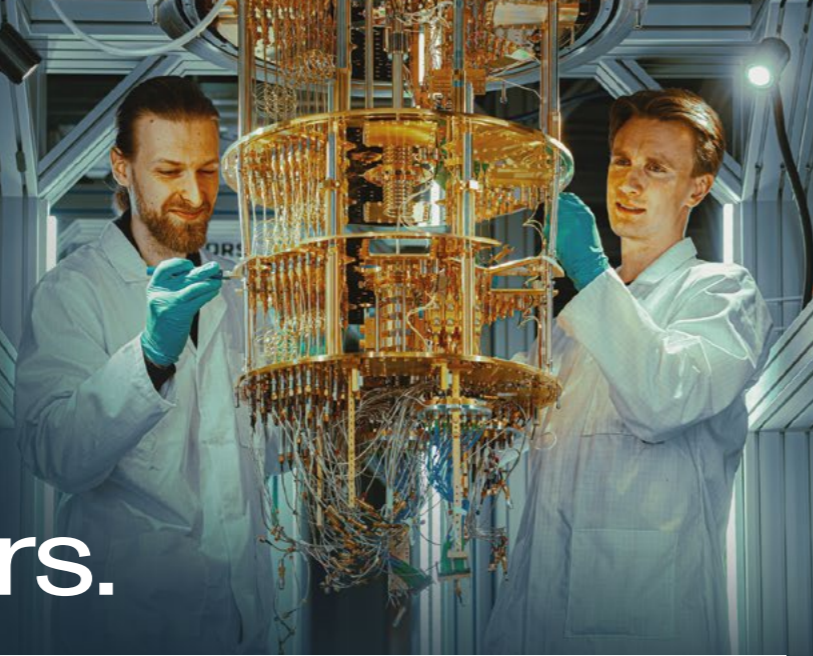

Founded in	2018	200+	Employees
Total funding	€200M+	41+	Nationalities
Systems sold	2	4	Offices

EXPLORE



IQM Product Brochure



Whitepaper: Bringing quantum acceleration to supercomputers



Scientific publication: Co-Design quantum simulation of nanoscale NMR



Scientific publication: Unimon qubit



Scientific publication: Long-distance transmon coupler with CZ gate fidelity above 99.8%

PEOPLE OBITUARIES

MARIE-NOËLLE MINARD 1947-2022

From the first Z to its lineshape

Marie-Noëlle Minard passed away on 15 May 2022. She began her career as a physicist in 1969, with a postgraduate thesis at the Institute of Nuclear Physics (IPN) in Orsay under the direction of Louis Massonnet, on the subject of high-energy neutron detectors. She joined the CNRS as a research associate, while still at the IPN, in 1972 and began her PhD studies exploring ways to detect exotic particles under the supervision of Michel Yvert. Minard defended her thesis in 1976 and joined the newly created Annecy particle-physics laboratory (LAPP). She then spent two years at SLAC, where she worked on the rapid-cycling bubble chamber. Back at LAPP in 1979, she joined the group of physicists involved in the UA1 collaboration at the CERN Sp \bar{p} S proton-antiproton collider. The group participated in the construction of the electromagnetic calorimeter, analysis tools, data taking and physics analyses.

With her colleagues at LAPP and CERN, Marie-Noëlle created an analysis to search for Z bosons, exploiting the UA1 data extracted online by the 168E emulators – the so-called “express line”. It was by analysing these events that Marie-Noëlle spotted the first Z boson on the night of 4 May 1983 – a source of immense pleasure in her career.

In 1987 Marie-Noëlle turned to LEP physics. She created, with Daniel Décamp, the ALEPH group at LAPP. This idea came up against obstacles: there was already an L3 group, and the rule at the time was that each IN2P3 laboratory could only participate in one experiment at LEP (with one exception). This occasion demonstrated the



Marie-Noëlle Minard in the LHCb control room.

measure of Marie-Noëlle's determination: when she was convinced of the merits of a project, her enthusiasm and energy were such that she was able to convince even the most reluctant. She finally obtained the green light for an ALEPH team at LAPP, which, under her direction, made many contributions to the experiment. She herself was run coordinator, responsible for calibration, and a pillar of the di-fermion analysis group (measuring the Z lineshape).

In the early 2000s Jacques Lefrançois invited Marie-Noëlle to join the LHCb collaboration. The team at LAPP, under her direction, made a major contribution to the experiment, particularly in the construction and operation of calorimetric systems as well as in numerous physics analyses. Project manager of the calorimeter group during its start-up between 2008 and 2011, then assistant to the project manager until 2013, Marie-Noëlle participated in the commissioning and definition

of control and calibration procedures for the calorimeters and ensured the continuous monitoring of the gains and of the aging of the cells of the electromagnetic calorimeter throughout the first period of data taking (2011–2013).

Between 2000 and 2006 Marie-Noëlle was deputy director of LAPP, during which she strongly contributed to the definition and implementation of its scientific strategy. Very careful to communicate our science to the public, her creativity enabled her to organise several original and appreciated events. Marie-Noëlle supervised nine theses. For services rendered to research, she received one of the highest awards in France (de chevalier de la Légion d'honneur).

She was certainly demanding, much more of herself than of others, but always convinced that in a group everyone makes a positive contribution. A physicist and communicator of immense talent, she was above all a woman of limitless generosity, with a sometimes caustic sense of humour. She was brave and couldn't stand injustice, often expressing aloud what others were quietly thinking. Marie-Noëlle loved swimming, sailing, cooking, reading and welcoming her many friends and family to her table. Those who, like us, have had the chance to work with her will miss her boundless commitment, the relevance of her advice and her humanity. We are thinking of Claude, her husband of 50 years, and of her large family.

Her friends and colleagues.

DONALD HILL PERKINS 1925-2022

A force of particle physics

UK experimental particle physicist Don Perkins, who played a significant role in shaping the field from the 1940s onwards, passed away on 30 October at the age of 97.

After graduating from Imperial College, London, Perkins obtained a PhD under the supervision of George Paget Thomson, recipient of the 1937 Nobel Prize in Physics. As part of his thesis work, he took a photographic emulsion – a new medium for particle detection at the time – onto a Royal Air Force transport plane to record cosmic rays at altitude. This resulted in what was later recognised to be the first observation of the pion, published in *Nature* in 1947.



Don Perkins made some pioneering measurements of cosmic rays.

In 1951 Perkins joined another Nobel laureate, Cecil Powell, in Bristol where, working with Peter Fowler, he discovered some of the decay

properties of pions. This involved touring some of the world's mountain tops with photographic emulsions, as well as sending them into the stratosphere on balloons. As a result of their studies, Perkins and Fowler were the first to suggest that irradiation with negatively charged pions might be used to treat cancer. In 1965 Perkins moved to the University of Oxford where, under the overall leadership of Denys Wilkinson, he established a world-leading particle-physics group. One year later he was elected a Fellow of the Royal Society. In 1991 he received the Royal Medal of the Royal Society, among many honours that would crown his long career.

As modern electronic counters and bubble chambers began to replace emulsion techniques, Perkins worked at CERN, where in 1973 he contributed to the seminal discovery of neutral currents with the Gargamelle bubble chamber. Thirty years later, in characteristic style and >



PEOPLE OBITUARIES

peppered with anecdotes, Perkins recounted the story of the neutral-current discovery in this magazine (*CERN Courier Commemorative Issue Willibald Jentschke* June 2003 p15).

In the late 1960s, when the scattering of electrons off protons in experiments at SLAC had established that the proton is not elementary, Perkins realised that neutrino scattering could give complementary information that helped prove the existence of fractionally charged quarks. He was also an early supporter of quantum chromodynamics, which explained why quarks are confined inside hadrons.

As the 1970s progressed, Perkins became

increasingly interested in proton decay, and was a leading advocate of the Soudan-II experiment in the US. Although Soudan-II never saw evidence of proton decay, the experiment made important contributions to advancing the field of neutrino physics.

Over his long career, Perkins' brilliance benefited generations of physics students, many of whom were drawn to particle physics through his textbook *Introduction to High Energy Physics*, first published in 1972 based on his undergraduate lectures and now in its fourth edition. Besides his experimental and theoretical contributions, Perkins was active in the governance of par-

ticle physics, having chaired both the nuclear physics board of the UK's former Science and Engineering Research Council and CERN's Scientific Policy Committee. He was a member of many international advisory committees and strategy meetings, including one in 1979 that led to the construction of the HERA electron-proton collider at DESY.

A charismatic and influential figure, his wisdom, delivered in a northern English accent and accompanied by his distinctive laugh, will be greatly missed by his many friends and colleagues.

Brian Foster *University of Oxford.*

SYLVIE ROSIER-LEES 1961-2022

A supersymmetry and dark-matter fan

Sylvie Rosier-Lees left us on 14 March 2022 following a long illness, which she endured with immense courage. Following her studies at the Ecole normale supérieure de Fontenay-Saint-Cloud, Sylvie began her research career in 1985 with a thesis on the L3 experiment at LEP. There were several of us – new to the Laboratoire d'Annecy de Physique des Particules (LAPP) at the time – with the idea of strengthening the existing L3 team, and Sylvie was our first student. Her inquisitive mind, tenacity and ability to face experimental problems – in particular concerning the calibration of the BGO crystals – quickly made her stand out within the collaboration.

Before becoming a highly regarded specialist in supersymmetry, she studied the identification of B mesons produced in Z decays, which made it possible to contribute to the first measurements of the $B^+ - B^0$ mixing parameter as well as the forward-backward asymmetry. Supersymmetry and the search for the neutralino set Sylvie on the quest for dark matter, to which she subsequently dedicated her entire career. In 2000 she joined the Alpha Magnetic Spectrometer (AMS) collaboration – a particle-physics detector installed on the International Space Station to identify and measure fluxes of cosmic rays. She took over responsibility for the readout electronics of the electromagnetic calorimeter, introducing independent rapid triggering based solely on calorimetry. Resistance to radiation, extended temperature range, low power consumption and operation in vacuum were all technical chal-



Sylvie Rosier-Lees in front of the launch pad at Cape Canaveral.

lenges that were met thanks to Sylvie's scientific rigour and exceptional human qualities. She had an enthusiasm and leadership that motivated and led to the success of everyone in her team. More than 15 years after its completion in 2005 and more than 10 years after its first signal on 19 May 2011, the calorimeter's electronics are still smoothly providing data. With AMS, she searched for dark matter via deformations of antiparticle fluxes, for example in the fraction of positrons detected, one of the first AMS publications.

In 2005 Sylvie created a HESS group at LAPP. The Namibia-based gamma-ray telescope had entered its second phase with the construction of the fifth telescope, the largest with a focal length of 36m. Sylvie took up the challenge of an

ambitious mechanical project to load and unload the camera – a cube 2.5m high and weighing 2.6 tonnes – from its data-taking position 5m from the ground to a shelter at ground level. She then explored the potential of the facility for dark-matter searches, since its size allowed the detection threshold of photons to be lowered to 50 GeV.

Throughout her career, Sylvie maintained close ties with phenomenologists and theorists. This collaboration began at LEP within the framework of a national supersymmetry group, where she coordinated an influential working group on the Minimal Supersymmetric Standard Model. Subsequently, with theorists, she obtained a lower bound on the mass of the lightest neutralino, a candidate for dark matter, by combining astrophysical, cosmological and collider observables. She also notably contributed to the development of an extension of the still widely used micROMEGAs code, making it possible to calculate the spectrum of positrons and antiprotons coming from the annihilation of dark-matter particles in the galaxy.

Always positive with students, Sylvie supervised or co-supervised around 10 theses. All these elements earned her the 2017 Joliot-Curie Prize awarded by the French Physical Society. Her enthusiasm, energy and good humour are sorely missed. We are thinking of Jean-Pierre, her husband, and her sons Edouard and Arthur.

Her friends and colleagues.

grand-unified theories “catalyse” proton decay – a beautiful and subtle non-perturbative effect that provides alternative experimental signatures in the search of monopoles.

Valery was one of the first physicists to realise the importance of inflationary theory, his 1982 work with Mikhail Sazhin and Alexey Veryaskin on the primordial production of gravitational waves establishing important constraints on the energy scale of the de-Sitter stage of inflation. In 1983 Rubakov (together with ▷

Mikhail Shaposhnikov) proposed alternatives to Kaluza-Klein compactification in theories with more than four space-time dimensions – one of which is now known as the brane-world scenario, where the particles of our world live on a four-dimensional defect embedded in a higher-dimensional universe.

He produced key contributions towards the understanding of the baryon asymmetry of the universe. His paper in 1985 with Vadim Kuzmin and Shaposhnikov revealed that non-perturbative processes can drive a rapid violation of baryon- and lepton-number conservation in the early universe – the basic ingredient of thermal leptogenesis. In 1998, together with Evgeny Akhmedov and Alexey Smirnov, he suggested how to produce the baryon asymmetry by relatively light right-handed neutrinos – an alternative to so-called Fukugita-Yanagida leptogenesis, which opened a unique possibility for experimental verification.

In a series of remarkable articles from 1987-1988, Valery, together with his PhD students George Lavrelashvili and Peter Tinyakov, discussed the physical impact of topology change in quantum gravity, analysing deep conceptual issues such as quantum coherence. In 1990-1991, together with Sergei Khlebnikov and Peter Tinyakov, he attacked the challenging problem of how to compute the probability of anomalous



Valery Rubakov left imprints in virtually all areas of particle physics and cosmology.

processes with baryon number non-conservation in very high-energy collisions above tens of TeV. He returned to this problem together with Fedor Bezrukov, Dmitry Levkov and Claudio Rebbi, in 2003, demonstrating that these reactions are exponentially suppressed, thus removing hopes of experimental verification of this phenomenon.

Valery made imprints in virtually all areas of particle physics and cosmology: supersymmetry phenomenology; the strong CP-problem; dark matter and dark energy; non-commutative field

theories; classical and quantum gravity; and alternatives to inflation, to name a few. His very last article, written with Christof Wetterich, was devoted to a physical concept of time for the beginning stage of the universe.

Valery was also an outstanding and passionate teacher, creating the “Rubakov School” of theoretical physics and cosmology in Moscow, and a successful scientific manager. As a research director of INR from 1987 to 1994, for example, he was responsible for the construction and operation of the Baksan neutrino observatory and the Baikal deep underwater neutrino telescope. Valery was a member of the CERN Scientific Policy Committee from 2014 to 2019 and served on the ICTP Scientific Council from 2010 to 2020. He was the recipient of numerous prizes, awards and distinctions and wrote several excellent textbooks, including *Classical Theory of Gauge Fields* (Princeton 2002).

Valery Rubakov was an exceptional person. He defended scientific thinking, the freedom of mind and fruitful collaboration between scientists from different countries. He will always be remembered for his kindness, sharp and inventive mind, charisma, honesty and integrity.

Dmitry Gorbunov *INR, Mikhail Shaposhnikov* *EPFL and Christof Wetterich* *Heidelberg University.*

VOLKER SOERSEL 1931-2022

Courage, persuasiveness and leadership

Experimentalist Volker Soergel passed away on 5 October at the age of 91. Born in Breslau in March 1931, Soergel was a brilliant experimental physicist and an outstanding leader, shaping particle physics for many years.

Receiving a doctorate from the University of Freiburg in 1956 under the tutelage of Wolfgang Gentner, Soergel remained at Freiburg until 1961, with a year at Caltech in 1957-1958. He then joined CERN as a research associate, working with Joachim Heintze on the beta decay of elementary particles, especially very rare decays of mesons and hyperons. Their results became milestones in the development of the Standard Model, resulting in the award of the German Physical Society's highest honour in 1963.

In 1965 Soergel became a professor at the University of Heidelberg. He continued his research at CERN while taking on important roles at the university: as director of the Institute of Physics, as dean and as a member of the university's administrative council. With vision and skill, he played a major role in shaping the university.

Important tasks outside Heidelberg followed. From 1976-1979 he chaired the DESY Scientific Council through a period that saw work begin on the electron-positron collider, PETRA. Under his leadership, the council played an important role in DESY's transition from national to international laboratory. In 1979 and 1980 he served

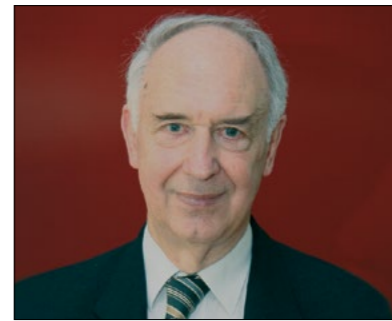

Volker Soergel was director of DESY during the period of German reunification.

as research director at CERN, helping pave the way for the collider experiments of the 1980s.

From 1981-1993 Soergel headed DESY, overseeing construction of the electron-proton storage ring, HERA, together with Björn Wiik and Gustav-Adolph Voss. HERA and its experiments benefited from large international contributions, mainly in the form of components and manpower: an approach that became known as the HERA model. Soergel's powers of persuasion, his reputation, and his negotiating skills led to support from institutes in Western Europe, Israel and Canada, as well as from Poland, Russia

and China. From 1996-2000 he headed the Max Planck Institute for Physics in Munich. Under his guidance, photon science became an important pillar of DESY research, first as a by-product of accelerators used for particle physics, then, with the inauguration of HASYLAB in 1981 and the conversion of DORIS, as an established research field that continues strongly to this day.

Soergel's time at DESY coincided with German reunification. He enabled the merger of the Institute for High Energy Physics in Zeuthen, near Berlin, with DESY and, together with Paul Söding, made Zeuthen a centre for astroparticle physics. Even before the Iron Curtain fell, Soergel personally ensured that Zeuthen scientists could work at DESY.

Volker Soergel received many honours. He was awarded the Federal Cross of Merit, 1st class, and honorary doctorates from the universities of Glasgow and Hamburg. He has left a lasting legacy. His love for physics was similar in intensity to his love for music. A gifted violin and viola player, he enjoyed making music with his wife and children, friends and colleagues. All who worked with him remain grateful for all they learned from him and will not forget his support and guidance.

Albrecht Wagner *DESY and Okinawa Institute of Science and Technology.*

BACKGROUND

Notes and observations from the high-energy physics community

Hyper or hype?

Wormholes hit the headlines in December following a quantum simulation that exhibits properties of the space-time sci-fi mainstays (*Nature* 612 51). Caltech particle physicist Maria Spiropulu and co-workers used Google's nine-qubit Sycamore processor to encode two entangled systems and then sent information between them. While the feat is not in doubt, claims that it allows quantum gravity to be studied in the lab generated much discussion online. "This experiment could have been performed without anyone involved even knowing Einstein's equations." (Martin Bauer, IPPP Durham). "It's not the real thing; it's not even close to the real thing; it's barely even a simulation of something-not-close-to-the-real-thing!" (Matt Strassler, Harvard). CERN theorist Alexander Zhiboedov set the *Courier* straight: "The physics that inspired this work is amazing and the physics behind the work itself is solid, but it's all about the interpretation – in particular the use of the term 'wormhole', which has pushed things out of all proportion."

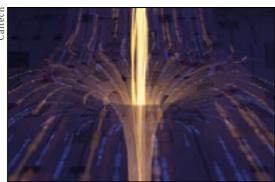

From the archive: January/February 1983

To be or not...

In October [1982] some 90 physicists met in Wingspread, Wisconsin to examine new evidence and theories concerning magnetic monopoles. Speculation grows that monopoles may have been as abundant as protons in the first blaze of creation, while arguments about the rate of expansion of the universe limit them to about one per 10^{18} protons. Challenges?

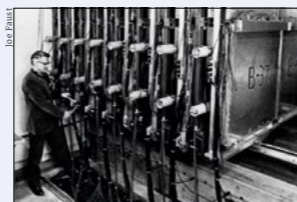

Finn Halbo adds the final touches to the beam dump experiment at the Stanford Linac.

Blas Cabrera's tantalizing monopole candidate, the conjecture that monopoles catalyse proton decay, a struggle to predict energy loss for slow monopoles, and an explosion in the number of monopole searches. The Wingspread meeting concluded that, if monopoles exist, they will be harder to see than earlier results suggested.

The most common light, penetrating particle is the neutrino, obtained from the weak decay of pions and kaons. However, theory doesn't exclude the existence of very light, highly penetrating particles – 'axions'. In beam dump experiments, pions and kaons are removed by a thick metal block, to reduce the supply of neutrinos, giving particles such as axions a better chance to show up. At the SLAC Linac electron beam, particles surviving the beam dump pass through a 200 metre-thick hill to reach a shower counter that catches photons from rare particle decays. An initial run early last year revealed no surprises.

At the Swiss SIN machine, an Aachen team reported an excess of forward photon pairs emerging from the beam dump. After further extensive examinations and consistency tests, the unexplained effect remains. Without a definite answer to the axion question, experimenters (and theoreticians) will continue to look for new particles.

• Based on text on pp 11–13 of *CERN Courier* January/February 1983.

Compiler's note

... and indeed the hunts go on.

The LHC experiment MoEDAL is designed to detect existing, long-lived magnetic monopoles, while condensed-matter physicists are searching for quasi-monopole equivalents resulting from interactions of known particles. Meanwhile, axions have become the favourite dark-matter candidate. Astrophysical limits put them within the scope of a lab experiment, albeit a notoriously difficult one. A worldwide collaboration at the Axion Dark Matter Experiment at the University of Washington hopes that ADMX will soon be that one.

A PhD in pictures



IceCube collaborator Kunal Deoskar, who defended his PhD at Stockholm University in December, has created a digested version of his thesis "dedicated to all my friends... who were too lazy to read my actual PhD thesis". With a cover (left) blending traditional Warli paintings with neutrino astrophysics, the online comic, containing chapters such as "Machine learning stuff", takes readers through his search for neutrinos from gamma-ray bursts. Clear and colourful diagrams, label- and unit-free plots and, naturally, the use of Comic Sans throughout, make for an engaging, informative read and an inspiration to future students (thesecretsketchbook.wordpress.com).

Media corner

"I know from my 40 years of experience in working on real-life physical phenomena that the whole idea of an ultimate law based on an equation using just the building blocks and fundamental forces is unworkable and essentially a fantasy."

Condensed-matter theorist **Sankar Das Sarma** writing in *New Scientist* (9 December) about the "non-existence" of the laws of physics.

"Higgs boson is one thing. Human beings are another. And this is something we are very happy to be part of."

Mike Lamont, CERN director for accelerators and technology, in *National Geographic* (6 December) on advances in FLASH radiotherapy (see p8).

"I have heard people calling for a CERN for the oceans, a CERN for the fight against cancer, a CERN for AI... But CERN is CERN and the model cannot be copied that easily."

Former director of research and innovation at the European Commission **Robert-Jan Smits** in a *Science Business* article (1 December) about the effect of online information on democracy.

5 m³
The volume of "Colossus", the largest and most powerful refrigerator at mK temperatures, currently under construction at Fermilab to enable a state-of-the-art quantum computer



RE-BASED HIGH-TEMPERATURE SUPERCONDUCTOR



WHY CHOOSE FUJIKURA?

- Superior in-field performance, high critical current and excellent mechanical properties for high field applications.
- Fujikura pioneered the key manufacturing techniques of IBAD and PLD.
- Excellent uniformity over long lengths.



 Substrate [Hastelloy®] 75/50µm	 Buffer Layer	 Buffer Layer	 Buffer Layer
 Buffer Layer MgO	 Superconducting Layer	 Protection Layer [Ag] 2µm	 Stabiliser [Cu Plating] 20µm



www.fujikura.co.uk

T: +44 (0) 208 240 2000

superconductors@fujikura.co.uk

Fujikura Europe Ltd
C51 Barwell Business Park
Leatherhead Road
Chessington
Surrey
KT2 9NY
United Kingdom





μ-CRATE
SINGLE-SLOT UTILITY
FOR VME MODULES

Move your VME board to your desk!

The μ-Crate is a mains-powered desktop device integrating a low-noise cooling vents system. The desktop form factor can be optionally converted into a 19" rack thanks to the included metal brackets.

The single-slot backplane supports VME64 and VME64X **CAEN** boards of the Digitizer 1.0, Digitizer 2.0 Families, the V2495 Programmable Logic Unit, as well as other **CAEN** boards.

Only VME Modules (one-unit, 6U x 160mm) with direct connection on the front panel (via USB-2.0/3.0, CONET optical link or 1/10 GbE) and/or not requiring VME bus control (VME protocols not supported) are compatible with the μ-Crate.

Features

- Mechanical compatibility: 1-unit VME 6U x 160 mm modules
- Standard power: +3.3 V 10.5 A, +5 V 10 A, +12 V 2 A, -12 V -2 A
- Fan speed control:
 - Manual by hardware button (high/low state)
 - Automatic only with Digitizer 2.0 series
- Mains powered 100 – 240 V AC (130 W) @ 50 / 60 Hz
- 19" rack mount kit adapter included



www.caen.it
Small details... Great differences