

GENERAL NOTES

DESIGN:.....AASHTO LRFD Bridge Design Specifications, 2017 Edition, with latest interim specifications.

LIVE LOAD SURCHARGE:.....Up to 2' of fill on level ground surface.

ADDITIONAL DEAD LOAD:.....Up to 2" Non-Structural Concrete on exterior face included.

SEISMIC PARAMETERS:..... $A_s \leq 0.40g$

FOUNDATION SOIL:..... $\phi \geq 28^\circ$; Special footing design is required where foundation material is incapable of supporting bearing stress listed in the table.

RETAINED SOIL:..... $32' \leq \phi \leq 36'$
 $120 \text{ pcf} \leq \gamma \leq 140 \text{ pcf}$

REINFORCED CONCRETE:.....Class A Concrete, $f'_c = 4,000 \text{ psi}$

REINFORCEMENT:.....ASTM A706 or A615, Grade 60, $F_y = 60,000 \text{ psi}$

LOAD COMBINATIONS AND LIMIT STATES:.....Service I = $1.0DC + 1.0EV + 1.0EH + 1.0LS$
 Strength I = $\alpha DC + \beta EV + \eta EH + 1.75LS$

Where:
 α :.....1.25 or 0.90, Whichever Controls Design
 β :.....1.35 or 1.00, Whichever Controls Design
 η :.....1.50 or 0.90, Whichever Controls Design
 DC:.....Dead Load of Structure Components
 EH:.....Horizontal Earth Fill Pressure
 EV:.....Vertical Earth Pressure from Earth Fill Weight
 LS:.....Live Load Surcharge

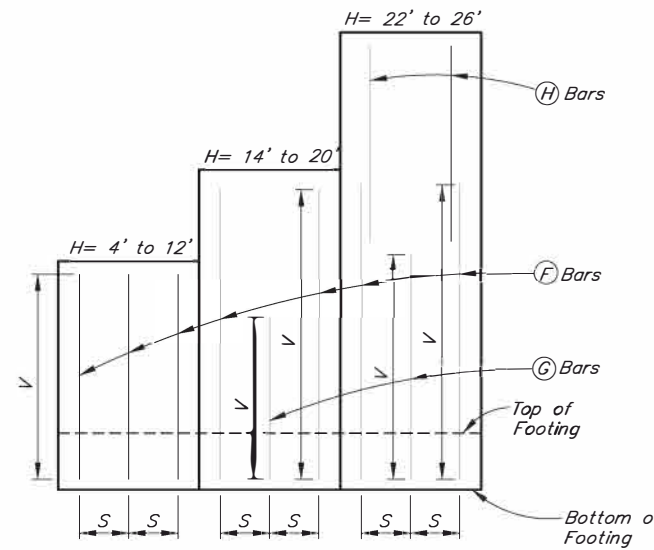

BACK FACE ELEVATION
No Scale

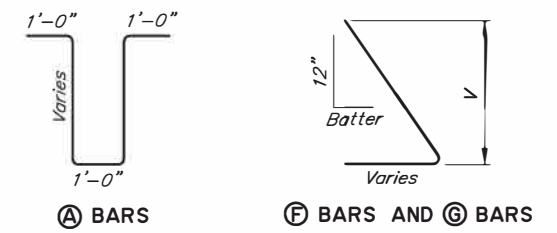

A BARS **F BARS AND G BARS**

See "B-07.10" for details not shown

ABBREVIATIONS:

- Ser I - Service I limit state
- Str I - Strength I limit state
- B' - Effective footing width (ft)
- qo - Gross uniform bearing stress (ksf)
- F.G. - Finished grade

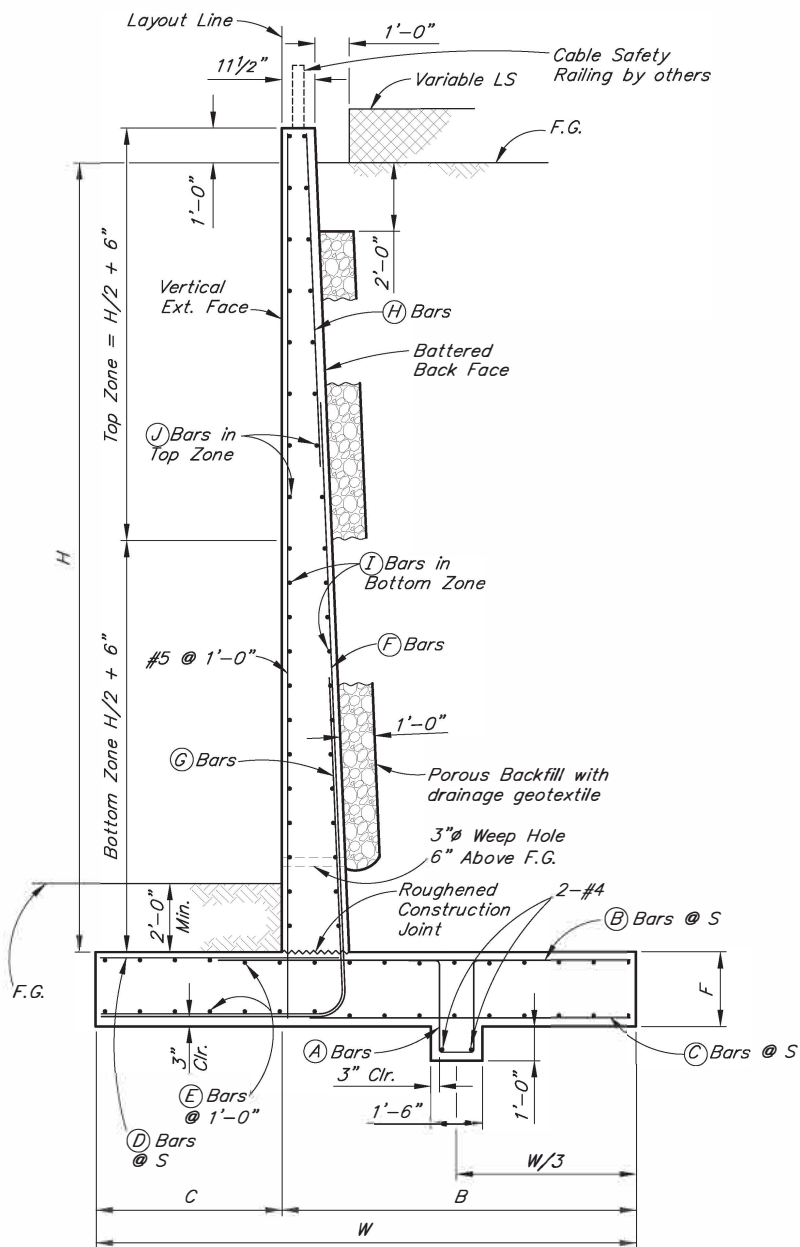

TYPICAL SECTION
No Scale

TABLE OF DIMENSIONS, REINFORCING STEEL, AND DATA

DIMENSIONS								A BARS		B BARS		C BARS		D BARS		E BARS		F BARS		G BARS		H BARS		I BARS		J BARS		EFFECTIVE FOOTING WIDTHS AND BEARING PRESSURES		Steel (Lbs/ft) Concrete (CF/ft)		
H	W	F	C	B	Batter	Spacing S	Size	Spacing	Length	Size	Length	Size	Length	Size	Length	Size	V	Length	Size	V	Length	Size	Spacing	Size	Spacing	Size	Spacing	Ser I B'-qo	Str I B'-qo			
4'-0"	4'-0"	1'-0"	1'-0"	3'-0"	1/2":12"	12"	#4	1'-6"	6'-2"	#4	2'-11"	#4	2'-6"	#4	1'-8"	#4	5'-7"	7'-5"	-	-	-	-	-	-	#4	1'-6"	#4	1'-6"	3.6-1.0	3.5-1.4	30-10.9	
6'-0"	4'-3"	1'-0"	1'-3"	3'-0"	1/2":12"	12"	#4	1'-6"	6'-2"	#4	2'-10"	#4	2'-5"	#4	1'-11"	#4	7'-7"	9'-9"	-	-	-	-	-	-	#4	1'-0"	#4	1'-6"	3.4-1.4	3.2-2.0	38-13.5	
8'-0"	4'-6"	1'-0"	1'-6"	3'-0"	1/2":12"	9"	#4	1'-6"	6'-2"	#4	2'-9"	#4	2'-4"	#4	2'-2"	#4	9'-7"	12'-1"	-	-	-	-	-	-	#4	1'-0"	#4	1'-6"	3.1-2.0	2.7-3.0	49-16.4	
10'-0"	5'-0"	1'-2"	1'-6"	3'-6"	1/2":12"	9"	#4	1'-6"	6'-6"	#4	3'-2"	#4	2'-9"	#4	2'-2"	#4	#5	11'-9"	14'-4"	-	-	-	-	-	-	#4	1'-0"	#4	1'-0"	3.0-2.8	2.6-4.4	66-20.4
12'-0"	5'-9"	1'-3"	1'-9"	4'-0"	1/2":12"	9"	#4	1'-6"	6'-8"	#4	3'-11"	#4	3'-2"	#4	2'-5"	#4	#6	13'-10"	16'-9"	-	-	-	-	-	-	#4	1'-0"	#4	1'-0"	3.5-3.2	2.9-5.1	87-24.7
14'-0"	6'-6"	1'-3"	2'-0"	4'-6"	1/2":12"	6"	#4	1'-6"	6'-8"	#4	4'-4"	#4	3'-7"	#4	2'-8"	#4	#6	15'-10"	19'-1"	#6	6'-4"	11'-1"	-	-	-	#4	1'-0"	#4	1'-0"	3.9-3.6	3.4-5.7	110-28.7
16'-0"	7'-3"	1'-6"	2'-6"	4'-9"	1/2":12"	6"	#4	1'-6"	7'-2"	#4	4'-6"	#4	3'-9"	#4	3'-2"	#4	#7	18'-1"	21'-11"	#7	7'-7"	12'-11"	-	-	-	#4	1'-0"	#4	1'-0"	4.3-4.0	3.6-6.4	144-34.7
18'-0"	8'-3"	1'-8"	2'-9"	5'-6"	1/2":12"	6"	#4	1'-6"	7'-6"	#5	5'-7"	#4	4'-5"	#4	3'-5"	#4	#8	20'-3"	24'-5"	#8	8'-8"	14'-4"	-	-	-	#5	1'-0"	#4	1'-0"	5.1-4.2	4.4-6.6	197-41.0
20'-0"	9'-6"	1'-8"	3'-0"	6'-6"	5/8":12"	6"	#4	1'-6"	7'-6"	#5	6'-3"	#4	5'-1"	#4	3'-8"	#5	#8	22'-3"	27'-0"	#8	10'-0"	15'-7"	-	-	-	#5	1'-0"	#4	1'-0"	6.5-4.3	5.8-6.5	225-49.0
22'-0"	11'-0"	2'-0"	3'-6"	7'-6"	5/8":12"	6"	#4	1'-6"	8'-2"	#6	7'-7"	#4	6'-0"	#4	4'-2"	#5	#8	17'-8"	23'-0"	#8	12'-5"	17'-9"	#5	16'-10"	#5	1'-0"	#4	1'-0"	8.1-4.3	7.4-6.3	258-59.4	
24'-0"	12'-3"	2'-3"	4'-0"	8'-3"	5/8":12"	6"	#4	1'-6"	8'-8"	#7	8'-7"	#4	6'-8"	#4	4'-8"	#5	#9	20'-10"	26'-9"	#9	13'-11"	19'-10"	#5	18'-2"	#5	1'-0"	#4	1'-0"	9.4-4.4	8.7-6.5	332-69.3	
26'-0"	14'-3"	2'-9"	4'-9"	9'-6"	5/8":12"	6"	#4	1'-6"	9'-8"	#8	10'-2"	#4	7'-10"	#4	5'-5"	#5	#10	24'-5"	31'-3"	#10	15'-7"	22'-5"	#5	19'-6"	#5	1'-0"	#5	1'-0"	11.8-4.4	11.1-6.3	449-85.6	

State of Alaska DOT&PF
 ALASKA STANDARD PLAN
CANTILEVER RETAINING WALL TYPE I

Adopted as an Alaska Standard Plan by: *Carolyn Morehouse*
 Carolyn Morehouse, P.E.
 Chief Engineer

Adoption Date: 07/17/2020

Last Code and Stds. Review By: NWM Date: 7/17/20
 Next Code and Standards Review date: 07/17/2029

DRAWN BY: MCM CHECKED BY: BAS DESIGNED BY: NWM B-04.10

GENERAL NOTES

DESIGN:.....AASHTO LRFD Bridge Design Specifications, 2017 Edition, with latest interim specifications.

LIVE LOAD SURCHARGE:.....Up to 2' of fill on level ground surface.

ADDITIONAL DEAD LOAD:.....Up to 2" Non-Structural Concrete on exterior face included.

SEISMIC PARAMETERS:.....0.40g < A_s ≤ 0.60g

FOUNDATION SOIL:.....φ ≥ 28'; Special footing design is required where foundation material is incapable of supporting bearing stress listed in the table.

RETAINED SOIL:.....32' ≤ φ ≤ 36'
120 pcf ≤ γ ≤ 140 pcf

REINFORCED CONCRETE:.....Class A Concrete, f_c = 4,000 psi

REINFORCEMENT:.....ASTM A706 or A615, Grade 60, F_y = 60,000 psi

LOAD COMBINATIONS AND LIMIT STATES:.....
Service I = 1.0DC + 1.0EV + 1.0EH + 1.0LS
Strength I = αDC + βEV + γEH + 1.75LS
Extreme I = 1.0DC + 1.0EV + 1.0EH + 1.0EQD + 1.0EQE

Where:
α:.....1.25 or 0.90, Whichever Controls Design
β:.....1.35 or 1.00, Whichever Controls Design
γ:.....1.50 or 0.90, Whichever Controls Design
DC:.....Dead Load of Structure Components
EH:.....Horizontal Earth Fill Pressure
EV:.....Vertical Earth Pressure from Earth Fill Weight
LS:.....Live Load Surcharge
EQE:.....Seismic Earth Pressure
EQD:.....Soil and Structural and Nonstructural Components Inertia

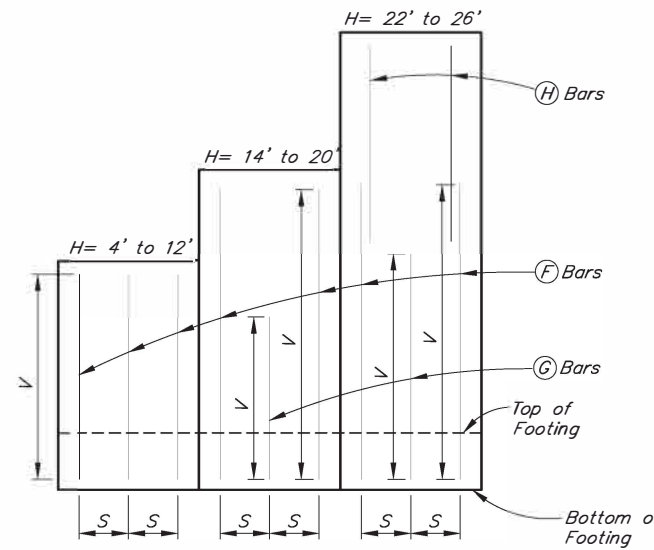

BACK FACE ELEVATION
No Scale

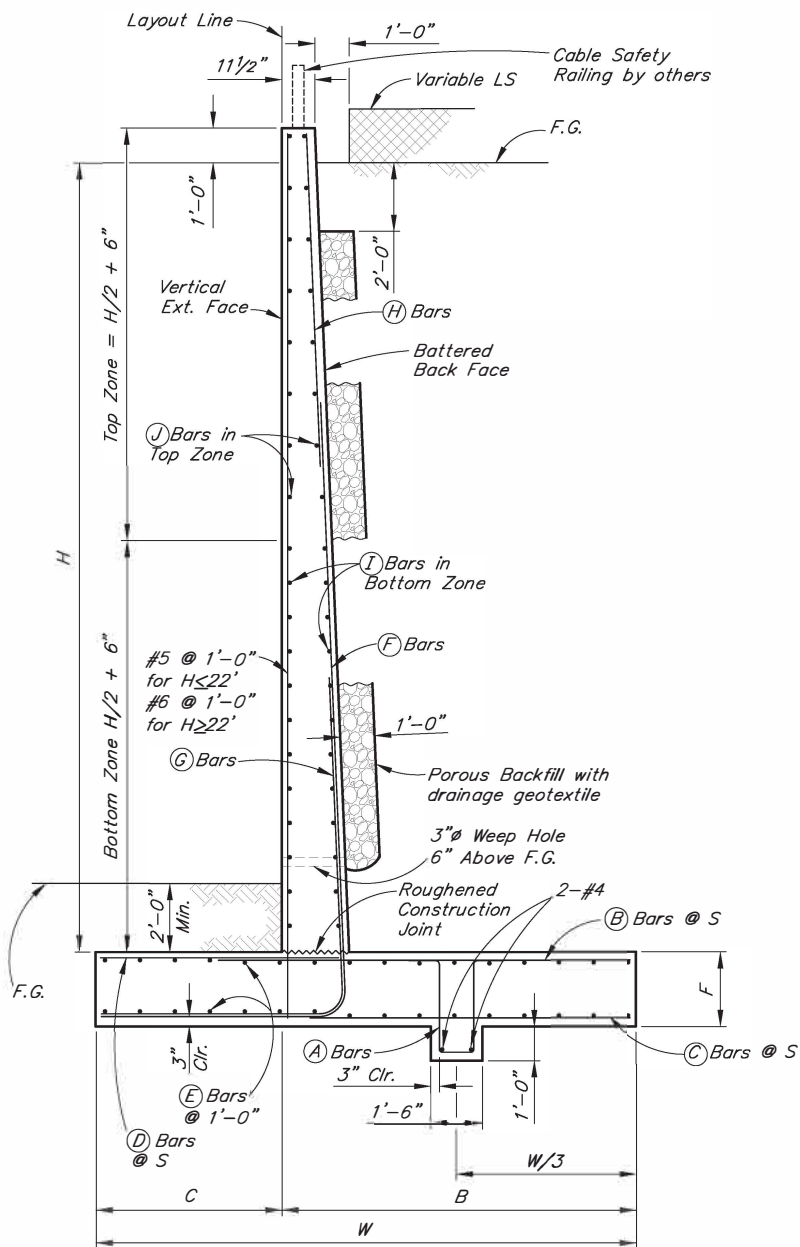

TYPICAL SECTION
No Scale

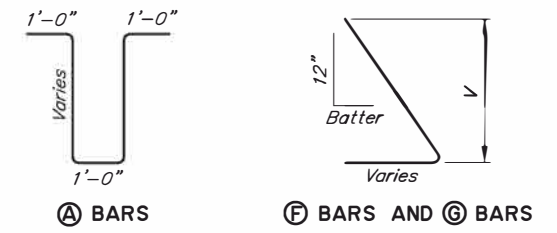

See "B-07.10" for details not shown

ABBREVIATIONS:

- Ser I - Service I limit state
- Str I - Strength I limit state
- B' - Effective footing width (ft)
- q_o - Gross uniform bearing stress (ksf)
- F.G. - Finished grade

TABLE OF DIMENSIONS, REINFORCING STEEL, AND DATA

DIMENSIONS							A BARS		B BARS		C BARS		D BARS		E BARS		F BARS		G BARS			H BARS		I BARS		J BARS		EFFECTIVE FOOTING WIDTHS AND BEARING PRESSURES			Steel (Lbs/ft) Concrete (CF/ft)	
H	W	F	C	B	Batter	Spacing S	Size	Spacing	Length	Size	Length	Size	Length	Size	Length	Size	Size	V	Length	Size	V	Length	Size	Length	Size	Spacing	Size	Spacing	Ser I B'-q _o	Str I B'-q _o		Ext I B'-q _o
4'-0"	4'-0"	1'-0"	1'-0"	3'-0"	1/2":12"	12"	#4	1'-6"	6'-2"	#4	2'-11"	#4	2'-6"	#4	1'-8"	#4	#4	5'-7"	7'-5"	-	-	-	-	-	#4	1'-6"	#4	1'-6"	3.6-1.0	3.5-1.4	2.7-1.2	30-10.9
6'-0"	4'-3"	1'-0"	1'-3"	3'-0"	1/2":12"	12"	#4	1'-6"	6'-2"	#4	2'-10"	#4	2'-5"	#4	1'-11"	#4	#4	7'-7"	9'-9"	-	-	-	-	-	#4	1'-0"	#4	1'-6"	3.4-1.4	3.2-2.0	2.4-1.9	38-13.5
8'-0"	4'-9"	1'-3"	1'-6"	3'-3"	1/2":12"	12"	#4	1'-6"	6'-8"	#4	3'-4"	#4	2'-7"	#4	2'-2"	#4	#5	9'-10"	12'-4"	-	-	-	-	-	#4	1'-0"	#4	1'-6"	3.4-2.0	3.0-3.0	2.0-3.1	50-17.8
10'-0"	5'-6"	1'-3"	1'-9"	3'-9"	1/2":12"	9"	#4	1'-6"	6'-8"	#4	3'-9"	#4	3'-0"	#4	2'-5"	#4	#5	11'-10"	14'-8"	-	-	-	-	-	#4	1'-0"	#4	1'-0"	3.9-2.3	3.5-3.5	2.1-4.0	69-21.5
12'-0"	6'-3"	1'-3"	2'-0"	4'-3"	1/2":12"	9"	#4	1'-6"	6'-8"	#4	4'-2"	#4	3'-5"	#4	2'-8"	#4	#6	13'-10"	17'-0"	-	-	-	-	-	#4	1'-0"	#4	1'-0"	4.4-2.7	3.9-4.1	2.2-5.1	89-25.3
14'-0"	7'-6"	1'-6"	2'-4"	5'-2"	1/2":12"	9"	#4	1'-6"	7'-2"	#5	5'-5"	#4	4'-3"	#4	3'-0"	#4	#7	16'-1"	19'-8"	#7	8'-9"	12'-4"	-	-	#4	1'-0"	#4	1'-0"	5.6-2.9	5.1-4.3	2.8-5.5	110-31.9
16'-0"	8'-3"	1'-8"	2'-9"	5'-6"	5/8":12"	9"	#4	1'-6"	7'-6"	#5	5'-6"	#4	4'-4"	#4	3'-5"	#4	#7	18'-3"	22'-7"	#7	10'-7"	14'-10"	-	-	#5	1'-0"	#4	1'-0"	6.0-3.3	5.4-4.9	3.0-7.0	131-39.1
18'-0"	9'-6"	1'-8"	3'-0"	6'-6"	5/8":12"	9"	#4	1'-6"	7'-6"	#7	7'-2"	#4	5'-3"	#4	3'-8"	#4	#8	20'-3"	24'-11"	#8	11'-10"	16'-6"	-	-	#5	1'-0"	#4	1'-0"	7.3-3.4	6.7-5.0	3.8-6.9	174-45.0
20'-0"	10'-3"	1'-10"	3'-4"	6'-11"	5/8":12"	6"	#4	1'-6"	7'-10"	#6	7'-1"	#4	5'-6"	#4	4'-0"	#5	#8	22'-5"	27'-6"	#8	11'-0"	16'-1"	-	-	#5	1'-0"	#4	1'-0"	7.7-3.8	7.1-5.6	3.7-8.4	239-52.0
22'-0"	11'-6"	2'-0"	3'-6"	8'-0"	5/8":12"	6"	#4	1'-6"	8'-2"	#7	8'-5"	#4	6'-6"	#4	4'-2"	#5	#9	18'-11"	24'-3"	#9	12'-5"	17'-9"	#5	16'-10"	#5	1'-0"	#4	1'-0"	9.0-4.1	8.3-6.0	4.5-8.6	305-60.4
24'-0"	12'-9"	2'-3"	4'-3"	8'-6"	3/4":12"	6"	#4	1'-6"	8'-8"	#7	8'-7"	#4	6'-8"	#4	4'-11"	#5	#9	21'-1"	27'-6"	#9	13'-4"	19'-9"	#5	18'-2"	#5	1'-0"	#5	1'-0"	10.2-4.2	9.5-6.1	5.2-8.8	356-73.7
26'-0"	14'-0"	2'-6"	4'-9"	9'-3"	3/4":12"	6"	#4	1'-6"	9'-2"	#7	9'-3"	#4	7'-3"	#4	5'-5"	#5	#10	24'-6"	31'-7"	#10	15'-0"	22'-0"	#5	19'-6"	#6	1'-0"	#5	1'-0"	11.5-4.4	10.7-6.4	6.0-9.0	455-85.2

State of Alaska DOT&PF
ALASKA STANDARD PLAN
CANTILEVER RETAINING WALL
TYPE I - HIGH SEISMIC

Adopted as an Alaska Standard Plan by: *Carolyn Morehouse*
Carolyn Morehouse, P.E.
Chief Engineer

Adoption Date: 07/17/2020

Last Code and Stds. Review By: NWM Date: 7/17/20

Next Code and Standards Review date: 07/17/2030

DRAWN BY: MCM CHECKED BY: BAS DESIGNED BY: NWM B-04.10HS

GENERAL NOTES

DESIGN:.....AASHTO LRFD Bridge Design Specifications, 2017 Edition, with latest interim specifications.

ADDITIONAL DEAD LOAD:.....Up to 2" Non-Structural Concrete on exterior face included.

SEISMIC PARAMETERS:..... $A_s \leq 0.40g$

FOUNDATION SOIL:..... $\phi \geq 28'$; Special footing design is required where foundation material is incapable of supporting bearing stress listed in the table.

RETAINED SOIL:..... $32' \leq \phi \leq 36'$
120 pcf $\leq \gamma \leq 140$ pcf

REINFORCED CONCRETE:.....Class A Concrete, $f_c = 4,000$ psi

REINFORCEMENT:.....ASTM A706 or A615, Grade 60, $F_y = 60,000$ psi

LOAD COMBINATIONS AND LIMIT STATES:.....Service I = 1.0DC + 1.0EV + 1.0EH
Strength I = $\alpha DC + \beta EV + \eta EH$

Where:
 α :.....1.25 or 0.90, Whichever Controls Design
 β :.....1.35 or 1.00, Whichever Controls Design
 η :.....1.50 or 0.90, Whichever Controls Design
DC:.....Dead Load of Structure Components
EH:.....Horizontal Earth Fill Pressure
EV:.....Vertical Earth Pressure from Earth Fill Weight

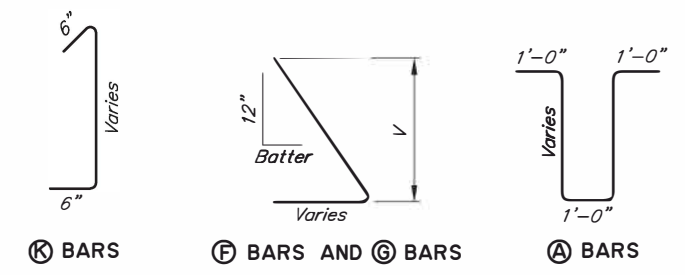
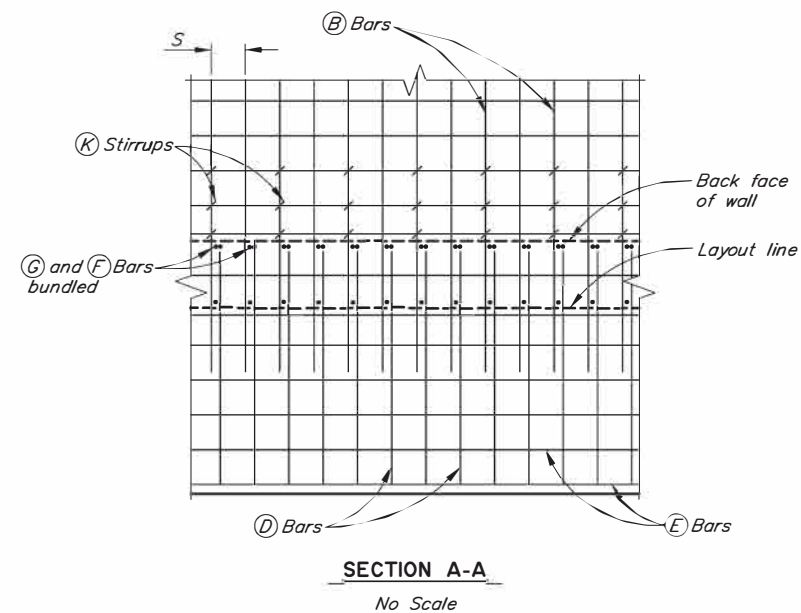
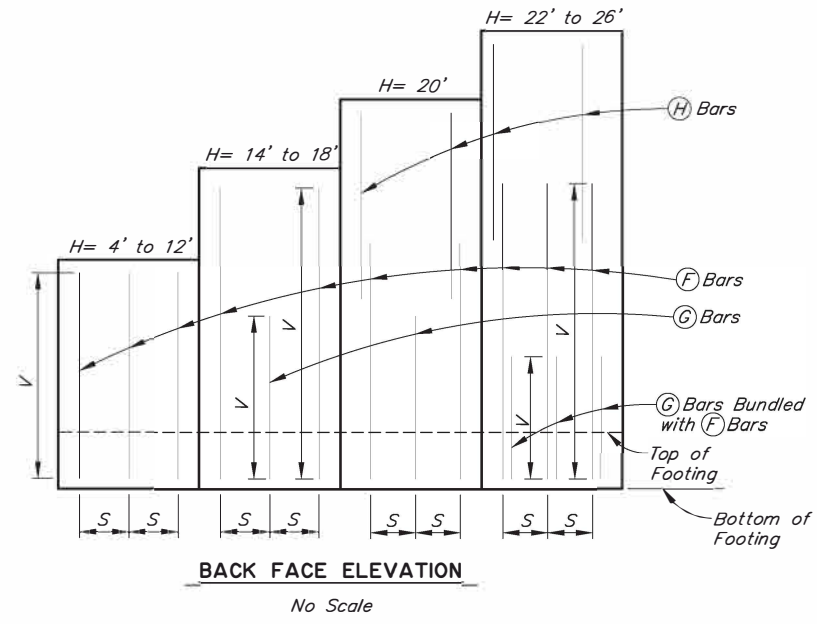
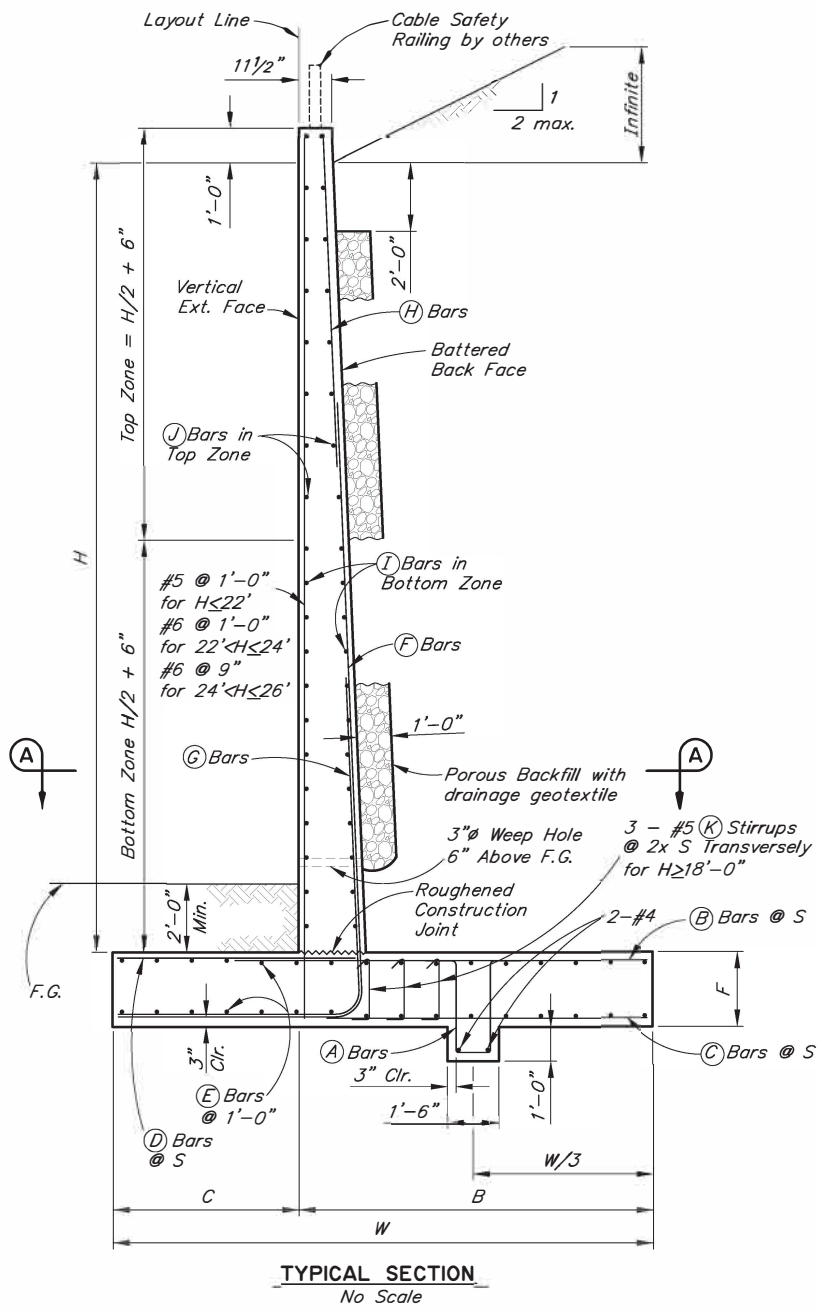

See "B-07.10" for details not shown

ABBREVIATIONS:

- Ser I - Service I limit state
- Str I - Strength I limit state
- B' - Effective footing width (ft)
- qo - Gross uniform bearing stress (ksf)
- F.G. - Finished grade

TABLE OF DIMENSIONS, REINFORCING STEEL, AND DATA

DIMENSIONS							A BARS		B BARS		C BARS		D BARS		E BARS		F BARS			G BARS			H BARS		I BARS		J BARS		EFFECTIVE FOOTING WIDTHS AND BEARING PRESSURES		Steel (Lbs/ft) Concrete (CF/ft)
H	W	F	C	B	Batter	Spacing S	Size	Spacing	Length	Size	Length	Size	Length	Size	Length	Size	Size	V	Length	Size	V	Length	Size	Length	Size	Spacing	Size	Spacing	Ser I B'-qo	Str I B'-qo	
4'-0"	4'-0"	1'-0"	1'-0"	3'-0"	1/2":12"	12"	#4	1'-6"	6'-2"	#4	2'-11"	#4	2'-6"	#4	1'-8"	#4	#4	4'-10"	7'-5"	-	-	-	-	-	#4	1'-6"	#4	1'-6"	3.5-1.1	3.4-1.4	30-10.9
6'-0"	4'-3"	1'-0"	1'-3"	3'-0"	1/2":12"	12"	#4	1'-6"	6'-2"	#4	2'-10"	#4	2'-5"	#4	1'-11"	#4	#4	6'-10"	9'-9"	-	-	-	-	-	#4	1'-0"	#4	1'-6"	3.2-1.6	3.0-2.2	38-13.5
8'-0"	4'-6"	1'-3"	1'-6"	3'-0"	1/2":12"	12"	#4	1'-6"	6'-8"	#4	3'-1"	#4	2'-4"	#4	2'-2"	#4	#5	8'-10"	12'-4"	-	-	-	-	-	#4	1'-0"	#4	1'-6"	2.6-2.6	2.3-4.0	50-17.5
10'-0"	5'-3"	1'-3"	1'-6"	3'-9"	1/2":12"	9"	#4	1'-6"	6'-8"	#4	3'-9"	#4	3'-0"	#4	2'-2"	#4	#6	10'-10"	14'-5"	-	-	-	-	-	#4	1'-0"	#4	1'-0"	2.6-3.8	2.2-5.9	76-21.2
12'-0"	6'-6"	1'-6"	1'-9"	4'-9"	1/2":12"	9"	#4	1'-6"	7'-2"	#5	5'-1"	#4	3'-11"	#4	2'-5"	#4	#7	12'-10"	17'-0"	-	-	-	-	-	#4	1'-0"	#4	1'-0"	3.3-4.3	2.9-6.7	106-27.3
14'-0"	7'-9"	1'-6"	2'-9"	5'-0"	5/8":12"	6"	#4	1'-6"	7'-2"	#4	4'-8"	#4	3'-11"	#4	3'-5"	#5	#7	14'-10"	20'-3"	#7	8'-5"	12'-7"	-	-	#5	1'-0"	#4	1'-0"	4.3-4.1	3.8-6.3	148-33.4
16'-0"	9'-9"	1'-8"	2'-9"	7'-0"	3/4":12"	6"	#4	1'-6"	7'-6"	#6	7'-2"	#4	5'-8"	#4	3'-5"	#5	#8	16'-10"	22'-9"	#8	9'-6"	14'-0"	-	-	#5	1'-0"	#4	1'-0"	6.1-4.4	5.5-6.5	207-43.1
18'-0"	11'-3"	1'-10"	3'-8"	7'-7"	3/4":12"	6"	#4	1'-6"	7'-10"	#7	8'-1"	#4	6'-1"	#4	4'-4"	#5	#9	18'-10"	25'-11"	#9	10'-11"	16'-5"	-	-	#5	1'-0"	#4	1'-0"	7.5-4.4	6.9-6.5	283-51.7
20'-0"	13'-3"	1'-10"	4'-8"	8'-7"	7/8":12"	6"	#4	1'-6"	7'-10"	#8	9'-1"	#4	6'-9"	#4	5'-4"	#5	#9	17'-5"	25'-10"	#9	11'-7"	18'-5"	#5	22'-6"	#6	1'-0"	#5	1'-0"	9.6-4.3	9.0-6.2	358-62.0
22'-0"	15'-0"	1'-10"	5'-3"	9'-9"	7/8":12"	6"	#4	1'-6"	7'-10"	#9	10'-10"	#4	7'-9"	#4	5'-11"	#5	#8	19'-7"	28'-9"	#8	11'-8"	19'-3"	#5	24'-6"	#5	1'-0"	#5	1'-0"	11.4-4.4	10.7-6.4	495-70.4
24'-0"	19'-0"	2'-0"	6'-0"	13'-0"	7/8":12"	6"	#4	1'-6"	8'-2"	2x#9	14'-0"	#4	10'-11"	#4	6'-8"	#6	#9	21'-7"	31'-9"	#9	13'-1"	21'-7"	#7	27'-2"	#6	1'-0"	#5	1'-0"	16.3-4.4	15.6-6.2	807-86.3
26'-0"	22'-3"	2'-6"	7'-6"	14'-9"	1":12"	6"	#4	1'-0"	9'-2"	2x#10	16'-2"	#4	12'-2"	#4	8'-2"	#6	#10	23'-10"	36'-5"	#10	15'-0"	25'-4"	#8	29'-5"	#6	1'-0"	#5	1'-0"	20.2-4.4	19.4-6.2	1131-113.4

State of Alaska DOT&PF
ALASKA STANDARD PLAN
CANTILEVER RETAINING WALL TYPE II

Adopted as an Alaska Standard Plan by: *Carolyn Morehouse*
Carolyn Morehouse, P.E.
Chief Engineer

Adoption Date: 07/17/2020

Last Code and Stds. Review By: NWM Date: 7/17/2020

Next Code and Standards Review date: 07/17/2030

DRAWN BY: MCM
CHECKED BY: BAS
DESIGNED BY: NWM
B-05.10

GENERAL NOTES

- DESIGN:.....AASHTO LRFD Bridge Design Specifications, 2017 Edition, with latest interim specifications.
- ADDITIONAL DEAD LOAD:.....Up to 2" Non-Structural Concrete on exterior face included.
- SEISMIC PARAMETERS:..... $0.40g < A_s \leq 0.60g$
- FOUNDATION SOIL:..... $\phi \geq 28'$; Special footing design is required where foundation material is incapable of supporting bearing stress listed in the table.
- RETAINED SOIL:..... $32' \leq \theta \leq 36'$
 $120 \text{ pcf} \leq \gamma \leq 140 \text{ pcf}$
- REINFORCED CONCRETE:.....Class A Concrete, $f_c = 4,000 \text{ psi}$
- REINFORCEMENT:.....ASTM A706 or A615, Grade 60, $F_y = 60,000 \text{ psi}$
- LOAD COMBINATIONS AND LIMIT STATES:.....
 - Service I = $1.0DC + 1.0EV + 1.0EH$
 - Strength I = $\alpha DC + \beta EV + \eta EH$
 - Extreme I = $1.0DC + 1.0EV + 1.0EH + 1.0EQD + 1.0EQE$

Where:

- α :.....1.25 or 0.90, Whichever Controls Design
- β :.....1.35 or 1.00, Whichever Controls Design
- η :.....1.50 or 0.90, Whichever Controls Design
- DC:.....Dead Load of Structure Components
- EH:.....Horizontal Earth Fill Pressure
- EV:.....Vertical Earth Pressure from Earth Fill Weight
- EQE:.....Seismic Earth Pressure
- EQD:.....Soil and Structural and Nonstructural Components Inertia

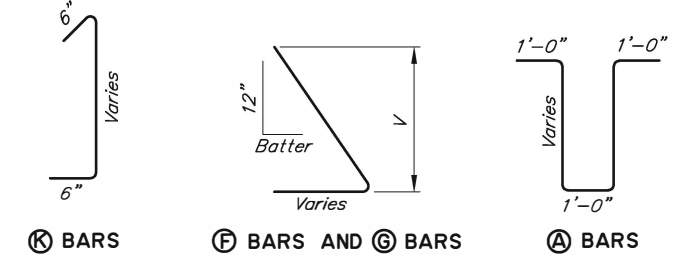

See "B-07.10" for details not shown

ABBREVIATIONS:

- Ser I - Service I limit state
- Str I - Strength I limit state
- Ext I - Extreme event I limit state
- B' - Effective footing width (ft)
- qo - Gross uniform bearing stress (ksf)
- F.G. - Finished grade

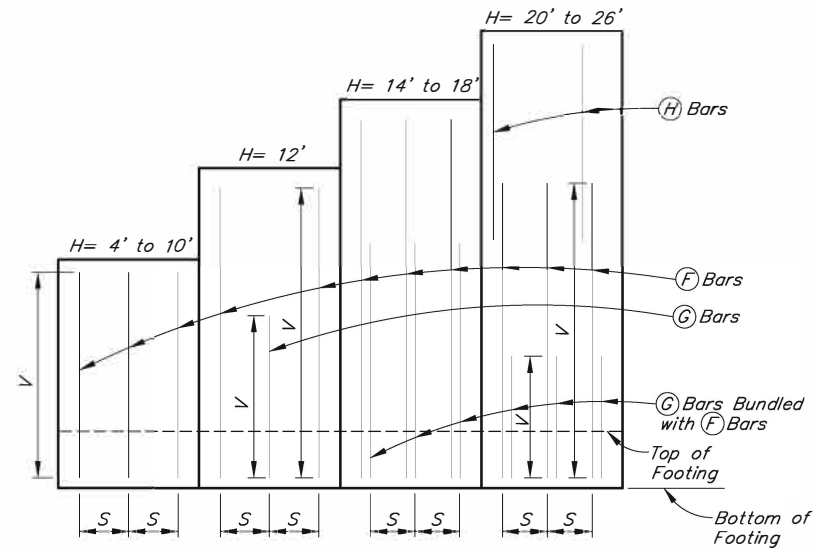

BACK FACE ELEVATION

No Scale

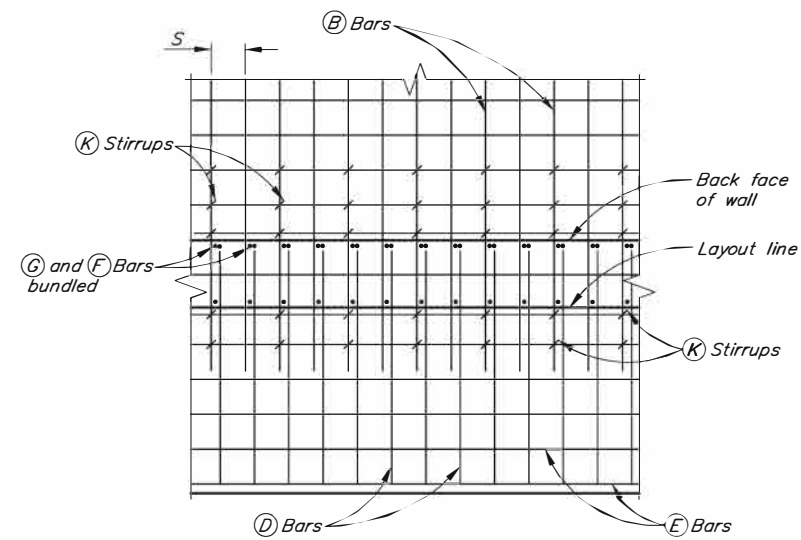

SECTION A-A

No Scale

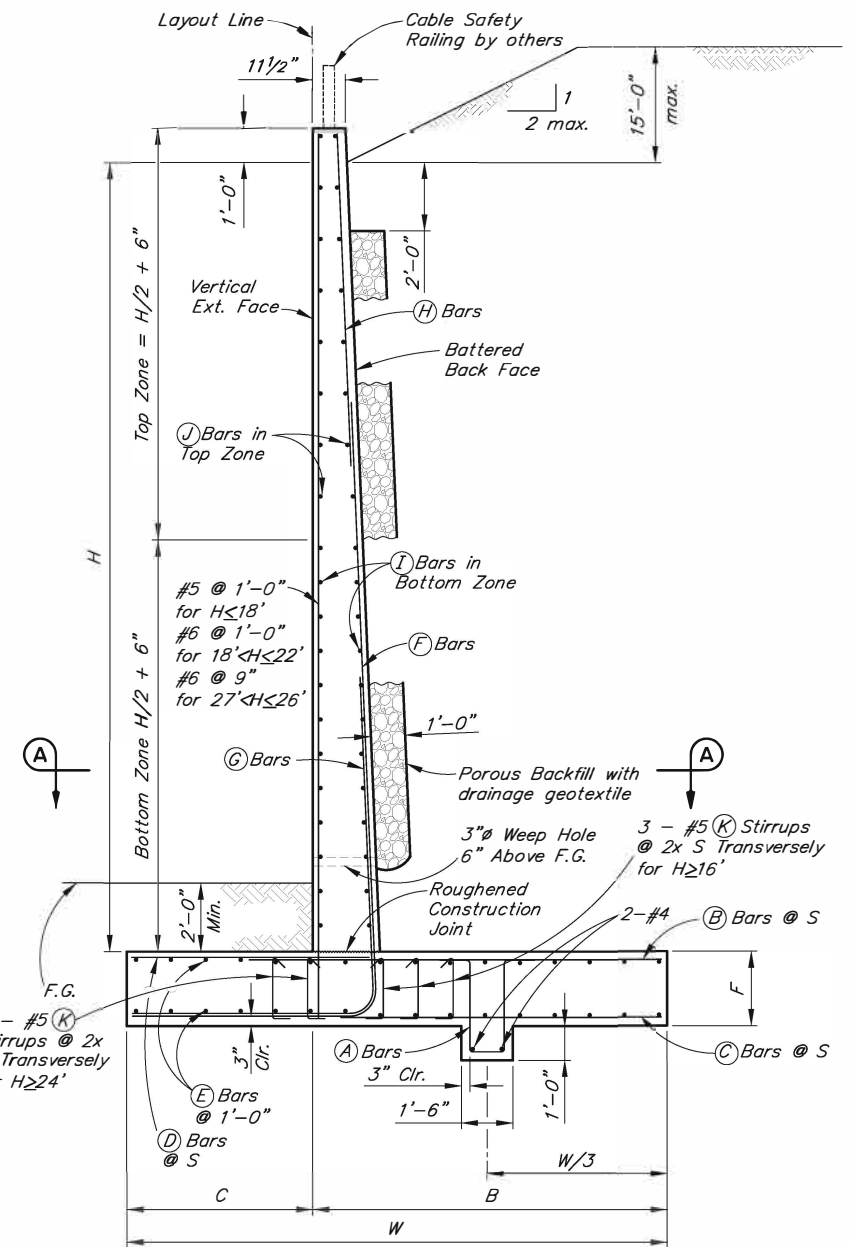

TYPICAL SECTION

No Scale

TABLE OF DIMENSIONS, REINFORCING STEEL, AND DATA

DIMENSIONS							A BARS		B BARS		C BARS		D BARS		E BARS		F BARS		G BARS			H BARS		I BARS		J BARS		EFFECTIVE FOOTING WIDTHS AND BEARING PRESSURES			Steel (Lbs/ft) Concrete (CF/ft)	
H	W	F	C	B	Batter	Spacing S	Size	Spacing	Length	Size	Length	Size	Length	Size	Length	Size	Size	V	Length	Size	V	Length	Size	Length	Size	Spacing	Size	Spacing	Ser I B'-qo	Str I B'-qo		Ext I B'-qo
4'-0"	6'-0"	1'-3"	1'-6"	4'-6"	1/2":12"	12"	#4	1'-6"	6'-8"	#4	4'-9"	#4	4'-0"	#4	2'-2"	#4	#5	5'-10"	8'-2"	-	-	-	-	-	#4	1'-6"	#4	1'-6"	5.9-1.0	5.8-1.3	2.3-3.5	40-14.4
6'-0"	7'-0"	1'-3"	2'-0"	5'-0"	1/2":12"	9"	#4	1'-6"	6'-8"	#4	5'-2"	#4	4'-5"	#4	2'-8"	#4	#6	7'-10"	10'-9"	-	-	-	-	-	#4	1'-0"	#4	1'-6"	6.8-1.2	6.7-1.7	2.4-4.7	63-18.0
8'-0"	8'-6"	1'-8"	2'-9"	5'-9"	1/2":12"	9"	#4	1'-6"	7'-6"	#5	6'-3"	#4	5'-1"	#4	3'-5"	#4	#8	10'-3"	14'-0"	-	-	-	-	-	#4	1'-0"	#4	1'-6"	8.1-1.6	7.9-2.1	3.0-5.4	105-26.0
10'-0"	9'-9"	1'-9"	3'-3"	6'-6"	1/2":12"	6"	#4	1'-6"	7'-8"	#5	6'-11"	#4	5'-9"	#4	3'-11"	#4	#9	12'-4"	16'-8"	-	-	-	-	-	#4	1'-0"	#4	1'-0"	9.2-1.9	8.9-2.6	3.4-6.2	188-31.7
12'-0"	11'-3"	1'-10"	3'-3"	8'-0"	5/8":12"	6"	#4	1'-6"	7'-10"	#6	8'-7"	#4	7'-0"	#4	3'-11"	#5	#9	14'-5"	19'-0"	#9	9'-1"	13'-8"	-	-	#4	1'-0"	#4	1'-0"	10.2-2.3	9.9-3.2	4.2-6.9	214-39.0
14'-0"	12'-3"	1'-10"	3'-9"	8'-6"	5/8":12"	6"	#4	1'-6"	7'-10"	#7	9'-4"	#4	7'-5"	#4	4'-5"	#5	#8	16'-5"	21'-7"	#8	9'-0"	14'-2"	-	-	#5	1'-0"	#4	1'-0"	10.9-2.6	10.6-3.7	4.3-8.0	321-44.2
16'-0"	13'-6"	2'-0"	4'-0"	9'-6"	3/4":12"	6"	#4	1'-6"	8'-2"	#8	10'-6"	#4	8'-2"	#4	4'-8"	#5	#9	18'-7"	24'-4"	#9	10'-5"	16'-1"	-	-	#5	1'-0"	#4	1'-0"	11.7-3.1	11.3-4.4	4.7-9.0	440-53.9
18'-0"	15'-0"	2'-0"	4'-6"	10'-6"	7/8":12"	6"	#4	1'-6"	8'-2"	#9	11'-11"	#4	8'-10"	#4	5'-2"	#5	#9	20'-7"	27'-2"	#9	11'-1"	17'-7"	-	-	#5	1'-0"	#4	1'-0"	13.0-3.4	12.5-4.8	5.8-8.8	505-62.9
20'-0"	16'-3"	2'-0"	5'-3"	11'-0"	1":12"	6"	#4	1'-6"	8'-2"	#10	12'-11"	#4	8'-11"	#4	5'-11"	#5	#9	18'-11"	28'-4"	#9	11'-9"	19'-5"	#8	16'-5"	#6	1'-0"	#5	1'-0"	14.0-3.7	13.4-5.2	6.5-9.0	636-72.5
22'-0"	18'-0"	2'-0"	5'-6"	12'-6"	1":12"	6"	#4	1'-6"	8'-2"	2x#9	13'-4"	#4	10'-3"	#4	6'-2"	#5	#10	22'-5"	32'-3"	#10	13'-2"	21'-2"	#8	17'-9"	#6	1'-0"	#5	1'-0"	15.6-4.1	15.0-5.8	8.0-8.8	860-81.6
24'-0"	19'-6"	2'-3"	6'-6"	13'-0"	1":12"	6"	#4	1'-6"	8'-8"	2x#9	13'-8"	#4	10'-7"	#4	7'-2"	#6	#10	23'-7"	34'-10"	#10	15'-4"	24'-6"	#9	19'-8"	#6	1'-0"	#5	1'-0"	17.0-4.3	16.3-6.1	9.1-8.8	986-95.4
26'-0"	22'-0"	2'-6"	7'-6"	14'-6"	1 1/8":12"	6"	#4	1'-6"	9'-2"	2x#10	15'-8"	#4	11'-8"	#4	8'-2"	#6	#11	25'-3"	38'-2"	#11	15'-8"	26'-4"	#10	21'-9"	#6	1'-0"	#5	1'-0"	19.7-4.5	18.9-6.3	11.9-8.0	1291-116.6

State of Alaska DOT&PF
ALASKA STANDARD PLAN
CANTILEVER RETAINING WALL
TYPE II - HIGH SEISMIC

Adopted as an Alaska Standard Plan by: *Carolyn Morehouse*
Carolyn Morehouse, P.E.
Chief Engineer

Adoption Date: 07/17/2020

Last Code and Stds. Review
By: NWM Date: 7/17/20
Next Code and Standards Review date: 07/17/2030

DRAWN BY: MCM CHECKED BY: BAS DESIGNED BY: NWM B-05.10HS

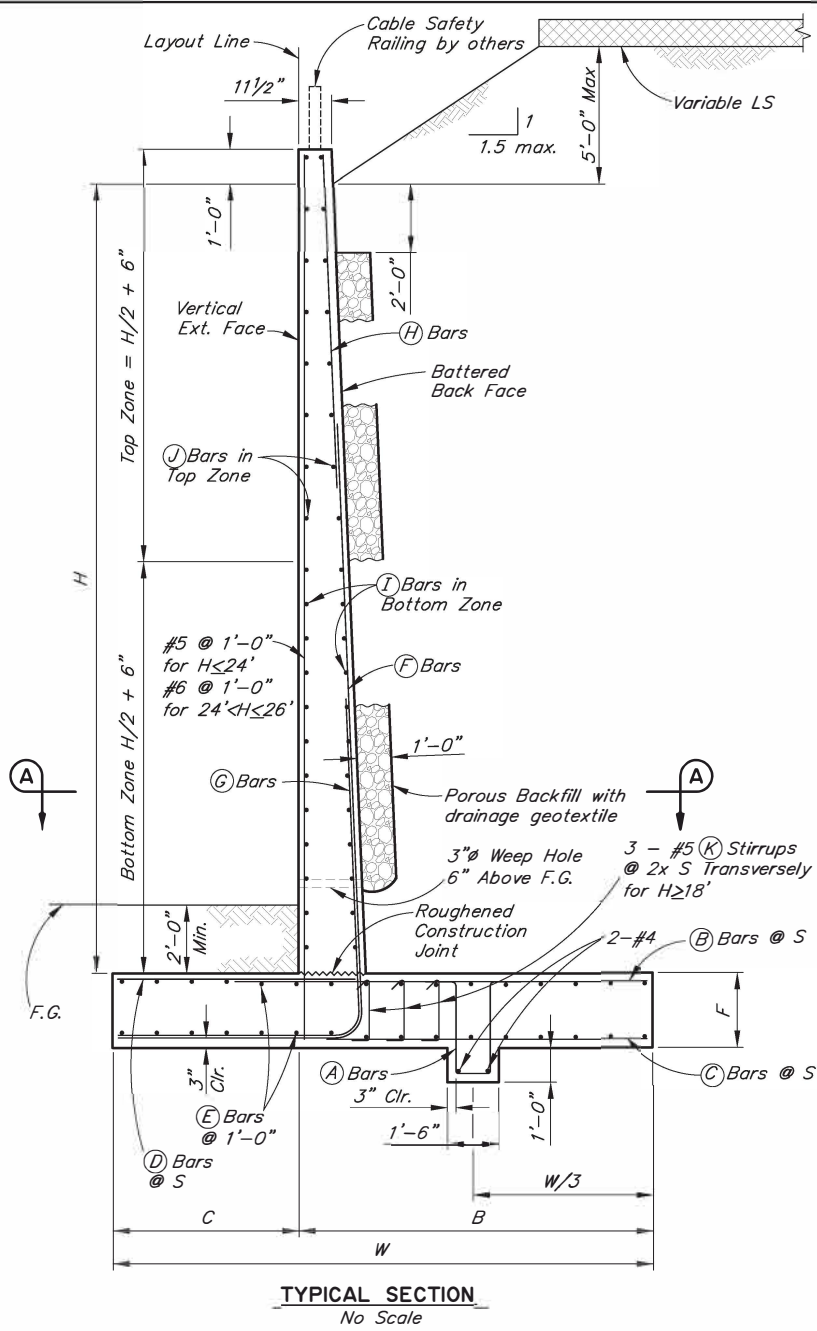

TYPICAL SECTION
No Scale

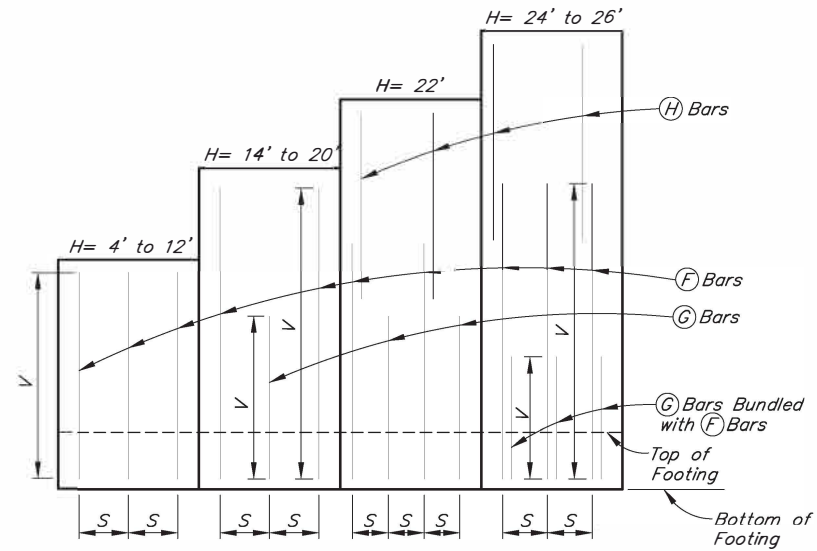

BACK FACE ELEVATION
No Scale

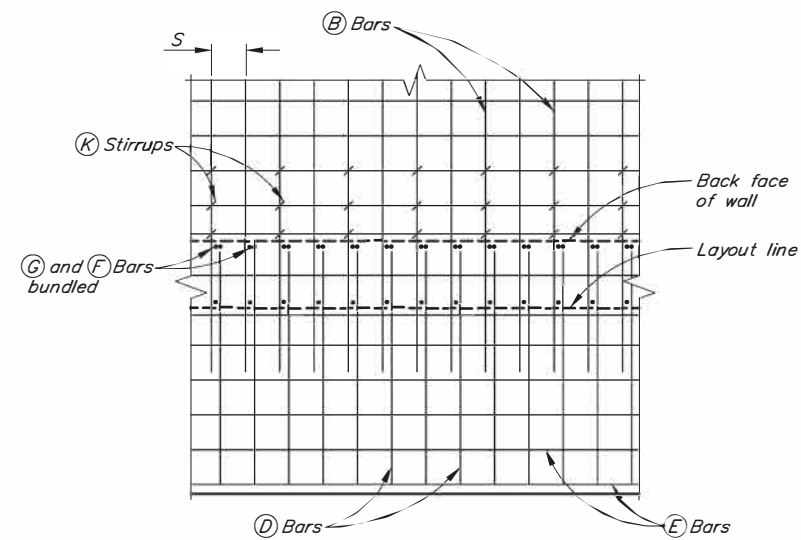

SECTION A-A
No Scale

GENERAL NOTES

- DESIGN:.....AASHTO LRFD Bridge Design Specifications, 2017 Edition, with latest interim specifications.
 - LIVE LOAD SURCHARGE:.....Up to 2' of fill on level ground surface.
 - ADDITIONAL DEAD LOAD:.....Up to 2" Non-Structural Concrete on exterior face included.
 - SEISMIC PARAMETERS:..... $A_s \leq 0.40g$
 - FOUNDATION SOIL:..... $\phi \geq 28^\circ$; Special footing design is required where foundation material is incapable of supporting bearing stress listed in the table.
 - RETAINED SOIL:..... $32^\circ \leq \phi \leq 36^\circ$
 $120 \text{ pcf} \leq \gamma \leq 140 \text{ pcf}$
 - REINFORCED CONCRETE:.....Class A Concrete, $f_c = 4,000 \text{ psi}$
 - REINFORCEMENT:.....ASTM A706 or A615, Grade 60, $F_y = 60,000 \text{ psi}$
 - LOAD COMBINATIONS AND LIMIT STATES:.....Service I = $1.0DC + 1.0EV + 1.0EH + 1.0LS$
Strength I = $\alpha DC + \beta EV + \eta EH + 1.75LS$
- Where:
- α :.....1.25 or 0.90, Whichever Controls Design
 - β :.....1.35 or 1.00, Whichever Controls Design
 - η :.....1.50 or 0.90, Whichever Controls Design
 - DC:.....Dead Load of Structure Components
 - EH:.....Horizontal Earth Fill Pressure
 - EV:.....Vertical Earth Pressure from Earth Fill Weight
 - LS:.....Live Load Surcharge

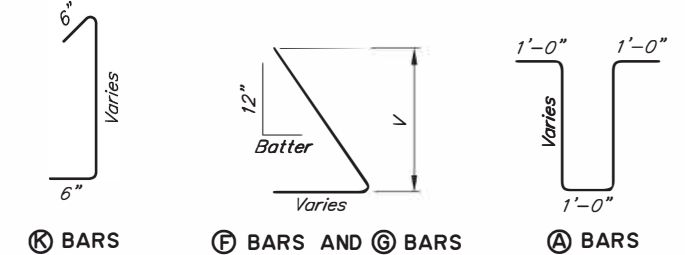

See "B-07.10" for details not shown

ABBREVIATIONS:

- Ser I - Service I limit state
- Str I - Strength I limit state
- B' - Effective footing width (ft)
- qo - Gross uniform bearing stress (ksf)
- F.G. - Finished grade

TABLE OF DIMENSIONS, REINFORCING STEEL, AND DATA

DIMENSIONS							A BARS		B BARS		C BARS		D BARS		E BARS		F BARS		G BARS			H BARS		I BARS		J BARS		EFFECTIVE FOOTING WIDTHS AND BEARING PRESSURES		Steel (Lbs/ft) Concrete (CF/ft)	
H	W	F	C	B	Batter	Spacing S	Size	Spacing	Length	Size	Length	Size	Length	Size	Length	Size	Size	V	Length	Size	V	Length	Size	Spacing	Size	Spacing	Ser I B'-qo	Str I B'-qo			
4'-0"	4'-0"	1'-0"	1'-3"	2'-9"	1/2":12"	12"	#4	1'-6"	6'-2"	#4	2'-8"	#4	2'-3"	#4	1'-11"	#4	#4	4'-10"	7'-8"	-	-	-	-	-	#4	1'-6"	#4	1'-6"	2.9-1.2	2.6-1.8	30-10.9
6'-0"	4'-3"	1'-0"	1'-3"	3'-0"	1/2":12"	12"	#4	1'-6"	6'-2"	#4	2'-10"	#4	2'-5"	#4	1'-11"	#4	#4	6'-10"	9'-9"	-	-	-	-	-	#4	1'-0"	#4	1'-6"	2.5-1.9	2.0-3.2	38-13.5
8'-0"	5'-0"	1'-2"	1'-9"	3'-3"	1/2":12"	9"	#4	1'-6"	6'-6"	#4	3'-0"	#4	2'-7"	#4	2'-5"	#4	#5	8'-10"	12'-6"	-	-	-	-	-	#4	1'-0"	#4	1'-6"	2.8-2.5	2.1-4.2	57-17.7
10'-0"	6'-0"	1'-3"	1'-9"	4'-3"	1/2":12"	9"	#4	1'-6"	6'-8"	#4	4'-3"	#4	3'-6"	#4	2'-5"	#4	#6	10'-10"	14'-8"	-	-	-	-	-	#4	1'-0"	#4	1'-0"	3.2-3.1	2.6-5.3	79-22.1
12'-0"	6'-9"	1'-6"	2'-3"	4'-6"	1/2":12"	9"	#4	1'-6"	7'-2"	#4	4'-5"	#4	3'-8"	#4	2'-11"	#4	#7	12'-10"	17'-6"	-	-	-	-	-	#4	1'-0"	#4	1'-0"	3.5-3.7	2.7-6.5	105-27.7
14'-0"	8'-3"	1'-8"	2'-6"	5'-9"	5/8":12"	9"	#4	1'-6"	7'-7"	#6	6'-3"	#4	4'-8"	#4	3'-2"	#4	#8	14'-10"	20'-2"	#8	10'-3"	14'-2"	-	-	#5	1'-0"	#4	1'-0"	4.7-4.0	3.9-6.5	141-35.5
16'-0"	9'-6"	1'-8"	3'-0"	6'-6"	5/8":12"	6"	#4	1'-6"	7'-6"	#7	7'-3"	#4	5'-4"	#4	3'-8"	#4	#8	16'-10"	22'-10"	#8	9'-6"	14'-0"	-	-	#5	1'-0"	#4	1'-0"	5.9-4.0	5.0-6.4	208-41.2
18'-0"	10'-9"	1'-10"	3'-6"	7'-3"	5/8":12"	6"	#4	1'-6"	7'-10"	#7	7'-11"	#4	6'-0"	#4	4'-2"	#5	#9	18'-10"	25'-7"	#9	10'-11"	16'-1"	-	-	#5	1'-0"	#4	1'-0"	6.9-4.3	6.0-6.7	278-48.9
20'-0"	12'-6"	2'-0"	3'-9"	8'-9"	5/8":12"	6"	#4	1'-6"	8'-2"	#8	9'-8"	#4	7'-4"	#4	4'-5"	#5	#10	20'-10"	28'-1"	#10	13'-1"	18'-6"	-	-	#5	1'-0"	#4	1'-0"	8.8-4.4	7.8-6.7	370-58.2
22'-0"	13'-9"	2'-0"	4'-3"	9'-6"	5/8":12"	6"	#4	1'-6"	8'-2"	#9	11'-1"	#4	8'-0"	#4	4'-11"	#5	#10	20'-6"	28'-4"	#10	15'-1"	21'-2"	-	-	#5	1'-0"	#4	1'-0"	10.3-4.5	9.4-6.6	433-64.9
24'-0"	15'-6"	2'-0"	5'-0"	10'-6"	5/8":12"	6"	#4	1'-6"	8'-2"	#10	12'-11"	#4	8'-11"	#4	5'-8"	#5	#8	21'-3"	29'-11"	#8	12'-6"	19'-5"	-	-	#5	1'-0"	#4	1'-0"	12.7-4.3	11.8-6.3	534-72.8
26'-0"	17'-0"	2'-0"	5'-3"	11'-9"	3/4":12"	6"	#4	1'-6"	8'-2"	2x#9	12'-10"	#4	9'-9"	#4	5'-11"	#5	#8	21'-7"	30'-10"	#8	13'-2"	20'-9"	-	-	#6	1'-0"	#5	1'-0"	14.5-4.5	13.6-6.5	664-84.2

State of Alaska DOT&PF
ALASKA STANDARD PLAN
CANTILEVER RETAINING WALL
TYPE III

Adopted as an Alaska Standard Plan by: *Carolyn Morehouse*
Carolyn Morehouse, P.E.
Chief Engineer

Adoption Date: 07/17/2020

Last Code and Stds. Review By: NWM Date: 7/17/20
Next Code and Standards Review date: 07/17/2030

DRAWN BY: MCM
CHECKED BY: BAS
DESIGNED BY: NWM
B-06.10

GENERAL NOTES

DESIGN:.....AASHTO LRFD Bridge Design Specifications, 2017 Edition, with latest interim specifications.

LIVE LOAD SURCHARGE:.....Up to 2' of fill on level ground surface.

ADDITIONAL DEAD LOAD:.....Up to 2" Non-Structural Concrete on exterior face included.

SEISMIC PARAMETERS:..... $0.40g < A_s \leq 0.60g$

FOUNDATION SOIL:..... $\phi \geq 28^\circ$; Special footing design is required where foundation material is incapable of supporting bearing stress listed in the table.

RETAINED SOIL:..... $32' \leq \phi \leq 36'$
 $120 \text{ pcf} \leq \gamma \leq 140 \text{ pcf}$

REINFORCED CONCRETE:.....Class A Concrete, $f_c = 4,000 \text{ psi}$

REINFORCEMENT:.....ASTM A706 or A615, Grade 60, $F_y = 60,000 \text{ psi}$

LOAD COMBINATIONS AND LIMIT STATES:.....
 Service I = $1.0DC + 1.0EV + 1.0EH + 1.0LS$
 Strength I = $\alpha DC + \beta EV + \eta EH + 1.75LS$
 Extreme I = $1.0DC + 1.0EV + 1.0EH + 1.0EQD + 1.0EQE$

Where:
 α :.....1.25 or 0.90, Whichever Controls Design
 β :.....1.35 or 1.00, Whichever Controls Design
 η :.....1.50 or 0.90, Whichever Controls Design
 DC:.....Dead Load of Structure Components
 EH:.....Horizontal Earth Fill Pressure
 EV:.....Vertical Earth Pressure from Earth Fill Weight
 EQE:.....Seismic Earth Pressure
 EQD:.....Soil and Structural and Nonstructural Components Inertia
 LS:.....Live Load Surcharge

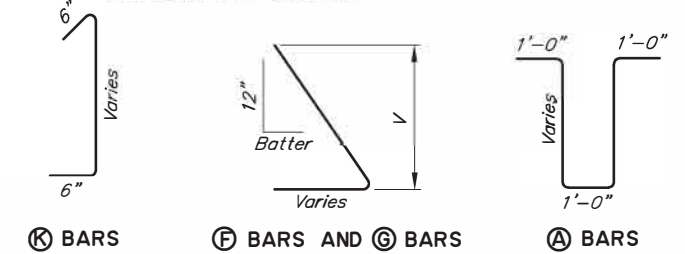

See "B-07.10" for details not shown

ABBREVIATIONS:

Ser I - Service I limit state
 Str I - Strength I limit state
 Ext I - Extreme event I limit state
 B' - Effective footing width (ft)
 qo - Gross uniform bearing stress (ksf)
 F.G. - Finished grade

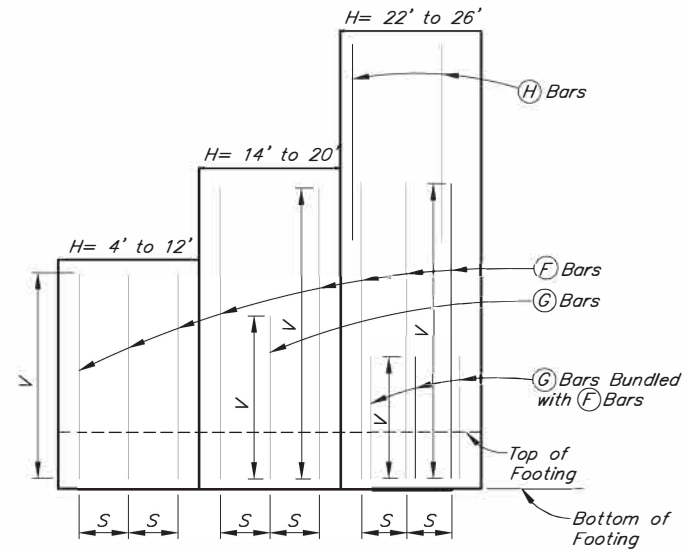

BACK FACE ELEVATION

No Scale

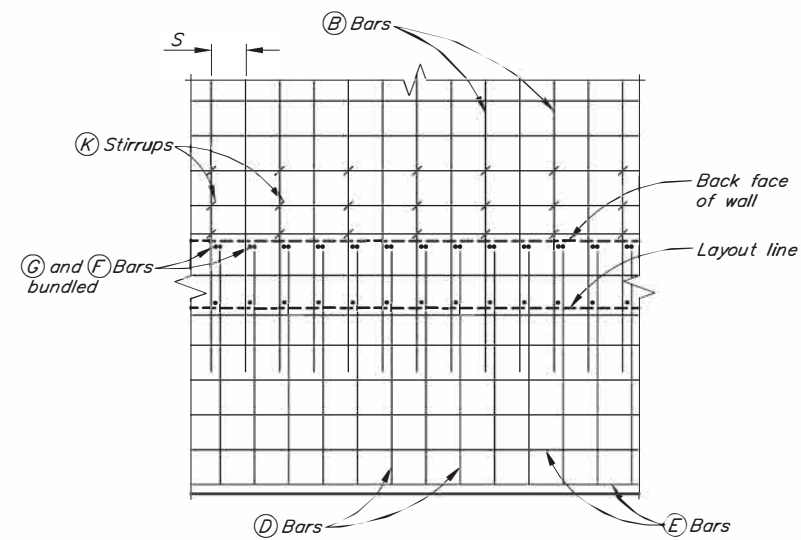

SECTION A-A

No Scale

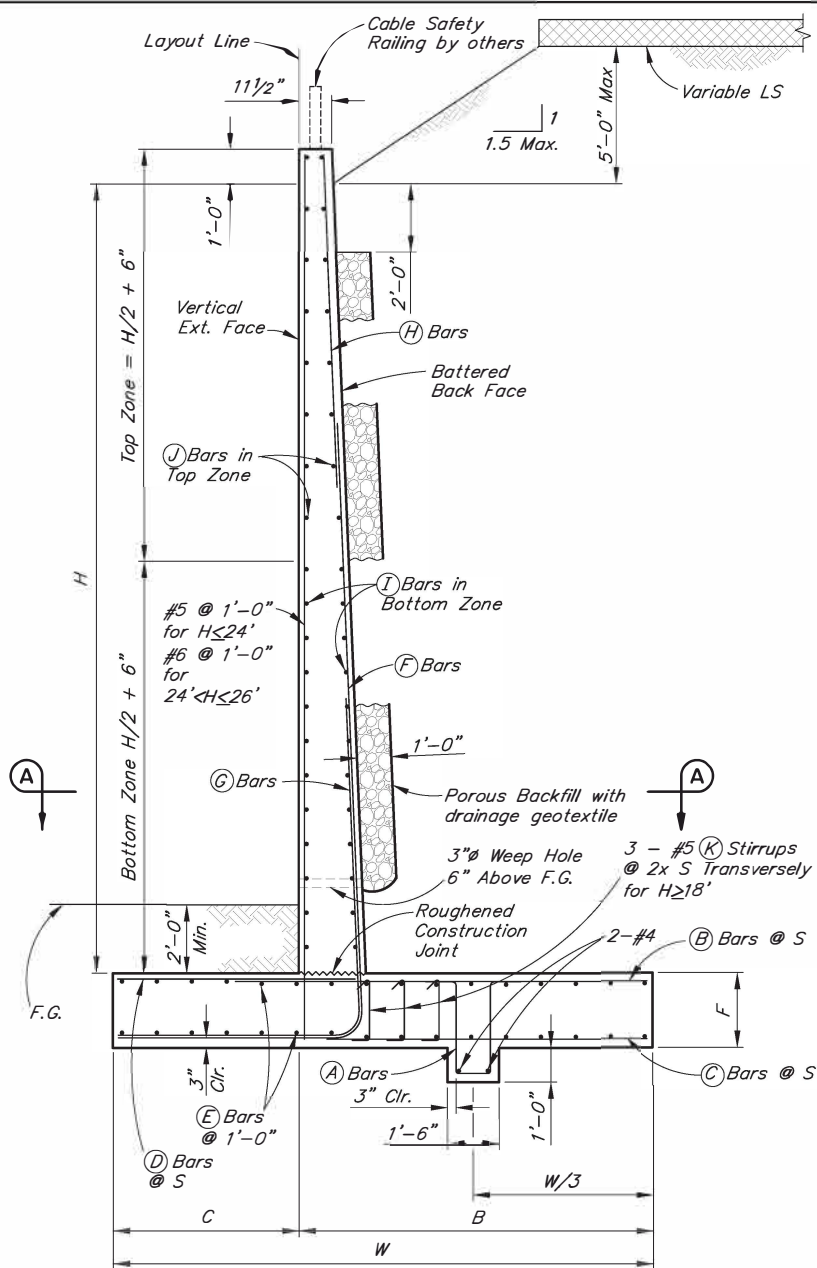

TYPICAL SECTION

No Scale

TABLE OF DIMENSIONS, REINFORCING STEEL, AND DATA

DIMENSIONS							A BARS		B BARS		C BARS		D BARS		E BARS		F BARS		G BARS			H BARS		I BARS		J BARS		EFFECTIVE FOOTING WIDTHS AND BEARING PRESSURES			Steel (Lbs/ft) Concrete (CF/ft)		
H	W	F	C	B	Batter	Spacing S	Size	Spacing	Length	Size	Length	Size	Length	Size	Length	Size	Size	V	Length	Size	V	Length	Size	Spacing	Size	Spacing	Size	Spacing	Ser I B'-qo	Str I B'-qo		Ext I B'-qo	
4'-0"	4'-0"	1'-0"	1'-3"	2'-9"	1/2":12"	12"	#4	1'-6"	6'-2"	#4	2'-8"	#4	2'-3"	#4	1'-11"	#4	#4	4'-10"	7'-8"	-	-	-	-	-	#4	1'-6"	#4	1'-6"	2.9-1.2	2.6-1.8	1.4-3.2	30-10.9	
6'-0"	5'-6"	1'-3"	1'-9"	3'-9"	1/2":12"	12"	#4	1'-6"	6'-8"	#4	3'-11"	#4	3'-2"	#4	2'-5"	#4	#6	6'-10"	10'-6"	-	-	-	-	-	#4	1'-0"	#4	1'-6"	4.2-1.5	3.7-2.2	2.2-3.5	51-16.2	
8'-0"	6'-6"	1'-3"	2'-0"	4'-6"	1/2":12"	12"	#4	1'-6"	6'-8"	#5	5'-0"	#4	3'-10"	#4	2'-8"	#4	#6	8'-10"	12'-10"	-	-	-	-	-	#4	1'-0"	#4	1'-6"	4.9-1.9	4.3-2.8	2.4-4.4	63-20.0	
10'-0"	7'-6"	1'-6"	2'-3"	5'-3"	1/2":12"	9"	#4	1'-6"	7'-2"	#5	5'-8"	#4	4'-6"	#4	2'-11"	#4	#7	10'-10"	15'-5"	-	-	-	-	-	#4	1'-0"	#4	1'-0"	5.4-2.4	4.8-3.6	2.6-5.7	100-25.9	
12'-0"	8'-6"	1'-8"	2'-9"	5'-9"	5/8":12"	9"	#4	1'-6"	7'-6"	#5	5'-11"	#4	4'-9"	#4	3'-5"	#4	#8	12'-10"	18'-4"	-	-	-	-	-	#4	1'-0"	#4	1'-0"	6.1-2.7	5.4-4.2	2.9-6.6	131-32.6	
14'-0"	9'-6"	1'-8"	2'-9"	6'-9"	5/8":12"	6"	#4	1'-6"	7'-6"	#6	7'-3"	#4	5'-8"	#4	3'-5"	#4	#8	14'-10"	20'-5"	#8	8'-10"	13'-0"	-	-	-	#5	1'-0"	#4	1'-0"	6.6-3.3	5.9-5.0	3.4-7.4	185-37.6
16'-0"	10'-6"	1'-10"	3'-3"	7'-3"	5/8":12"	6"	#4	1'-6"	7'-10"	#6	7'-7"	#4	6'-1"	#4	3'-11"	#5	#9	16'-10"	23'-3"	#9	10'-3"	15'-0"	-	-	-	#5	1'-0"	#4	1'-0"	7.3-3.6	6.5-5.5	3.7-8.1	243-44.6
18'-0"	11'-6"	2'-0"	3'-6"	8'-0"	5/8":12"	6"	#4	1'-6"	8'-2"	#7	8'-8"	#4	6'-9"	#4	4'-2"	#5	#10	18'-10"	25'-9"	#10	11'-10"	16'-11"	-	-	-	#5	1'-0"	#4	1'-0"	7.9-4.1	7.0-6.3	4.1-8.9	327-52.2
20'-0"	12'-9"	2'-0"	4'-0"	8'-9"	3/4":12"	6"	#4	1'-6"	8'-2"	#8	9'-6"	#4	7'-2"	#4	4'-8"	#5	#10	20'-10"	28'-7"	#10	12'-6"	18'-5"	-	-	-	#5	1'-0"	#4	1'-0"	9.2-4.3	8.2-6.5	5.2-8.4	371-61.0
22'-0"	14'-0"	2'-0"	4'-3"	9'-9"	3/4":12"	6"	#4	1'-6"	8'-2"	#9	11'-1"	#4	8'-0"	#4	4'-11"	#5	#8	17'-7"	25'-7"	#8	11'-10"	18'-2"	#6	17'-2"	#5	1'-0"	#5	1'-0"	10.7-4.4	9.8-6.5	6.2-8.4	472-68.1	
24'-0"	16'-0"	2'-2"	5'-0"	11'-0"	3/4":12"	6"	#4	1'-6"	8'-6"	#10	13'-2"	#4	9'-2"	#4	5'-8"	#5	#9	20'-9"	29'-11"	#9	13'-3"	20'-5"	#6	18'-6"	#5	1'-0"	#5	1'-0"	13.5-4.3	12.6-6.2	8.5-7.4	633-79.7	
26'-0"	17'-6"	2'-2"	5'-3"	12'-3"	7/8":12"	6"	#4	1'-6"	8'-6"	2x#9	13'-1"	#4	10'-0"	#4	5'-11"	#5	#9	20'-1"	29'-10"	#9	13'-11"	21'-9"	#7	20'-2"	#6	1'-0"	#5	1'-0"	15.2-4.5	14.4-6.4	10.0-7.4	755-91.9	

State of Alaska DOT&PF
 ALASKA STANDARD PLAN
**CANTILEVER RETAINING WALL
 TYPE III - HIGH SEISMIC**

Adopted as an Alaska Standard Plan by: *Carolyn Morehouse*
 Carolyn Morehouse, P.E.
 Chief Engineer

Adoption Date: 07/17/2020

Last Code and Stds. Review By: NWM Date: 7/17/20
 Next Code and Standards Review date: 07/17/2030

DRAWN BY: MCM CHECKED BY: BAS DESIGNED BY: NWM B-06.10HS

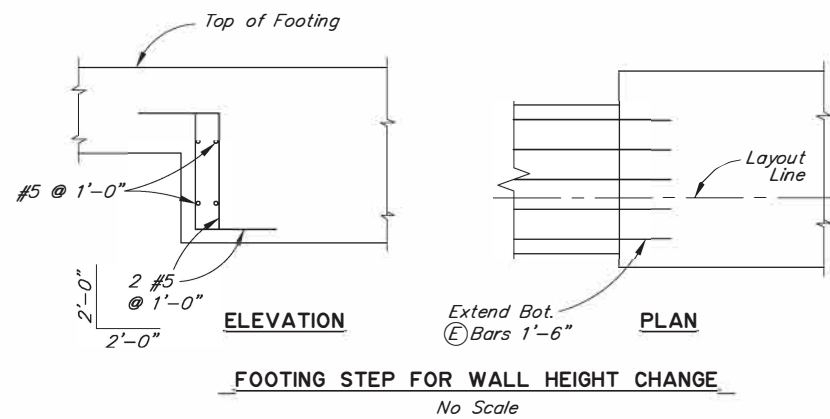
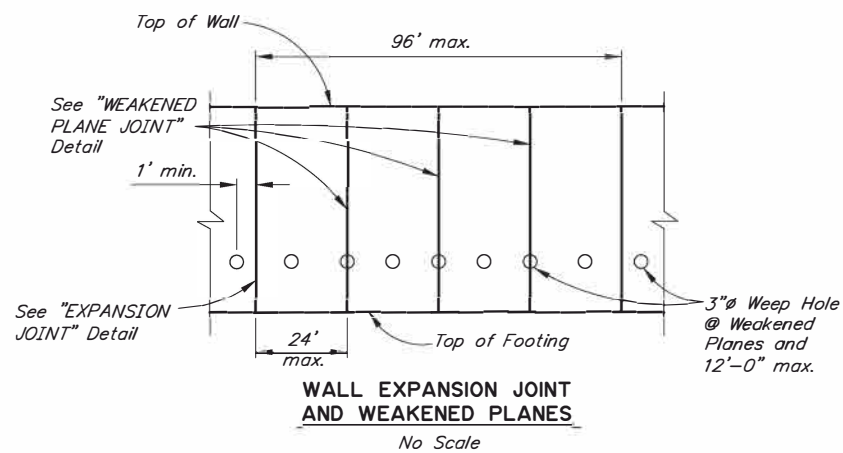
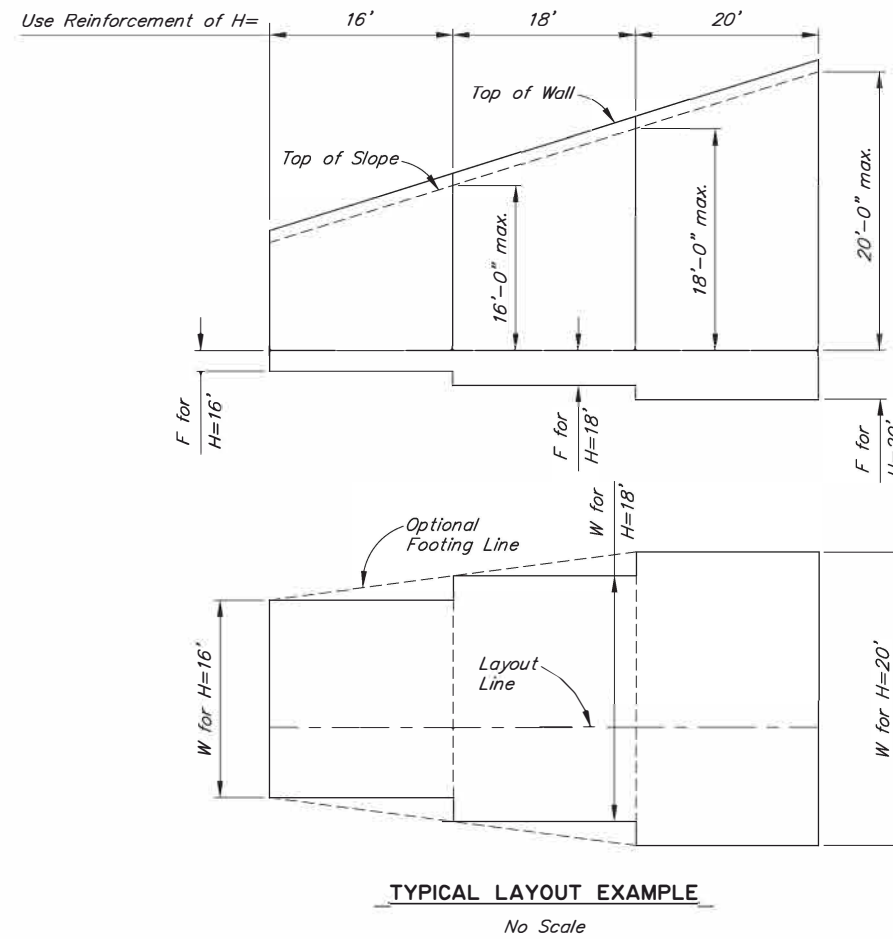
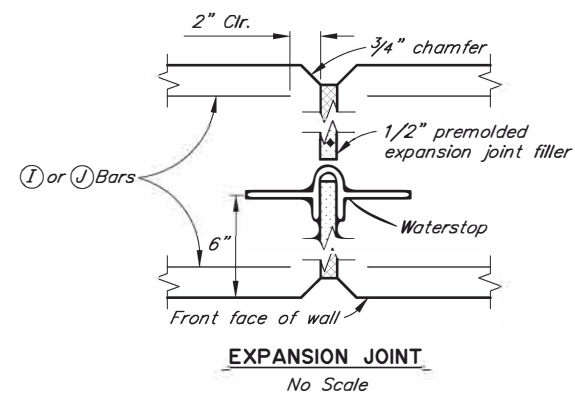
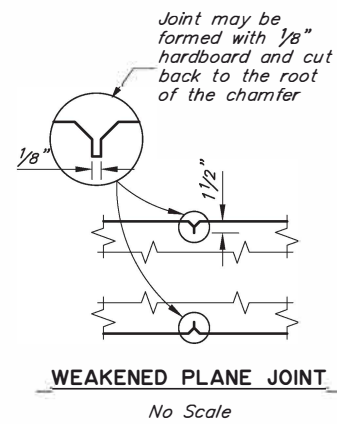
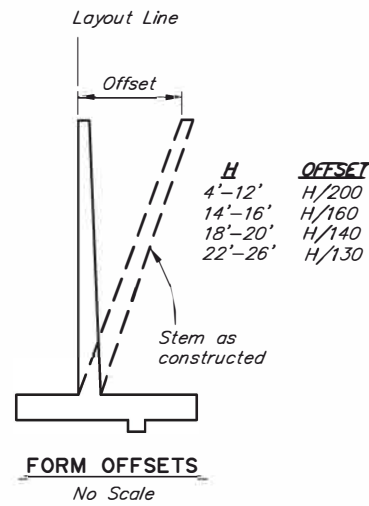

State of Alaska DOT&PF
ALASKA STANDARD PLAN
**CANTILEVER RETAINING WALL
DETAILS**

Adopted as an Alaska Standard Plan by: *Carolyn Morehouse*
Carolyn Morehouse, P.E.
Chief Engineer

Adoption Date: 07/17/2020

Last Code and Stds. Review
By: NWM Date: 7/17/20
Next Code and Standards Review date: 07/17/2030

DESIGNED BY: NWM CHECKED BY: BAS DRAWN BY: MCM

GENERAL NOTES:

1. Units shall be fabricated in accordance with AASHTO M-36 or M-218.
2. Installation procedure shall follow the manufacturers' recommendation for erecting bin walls.

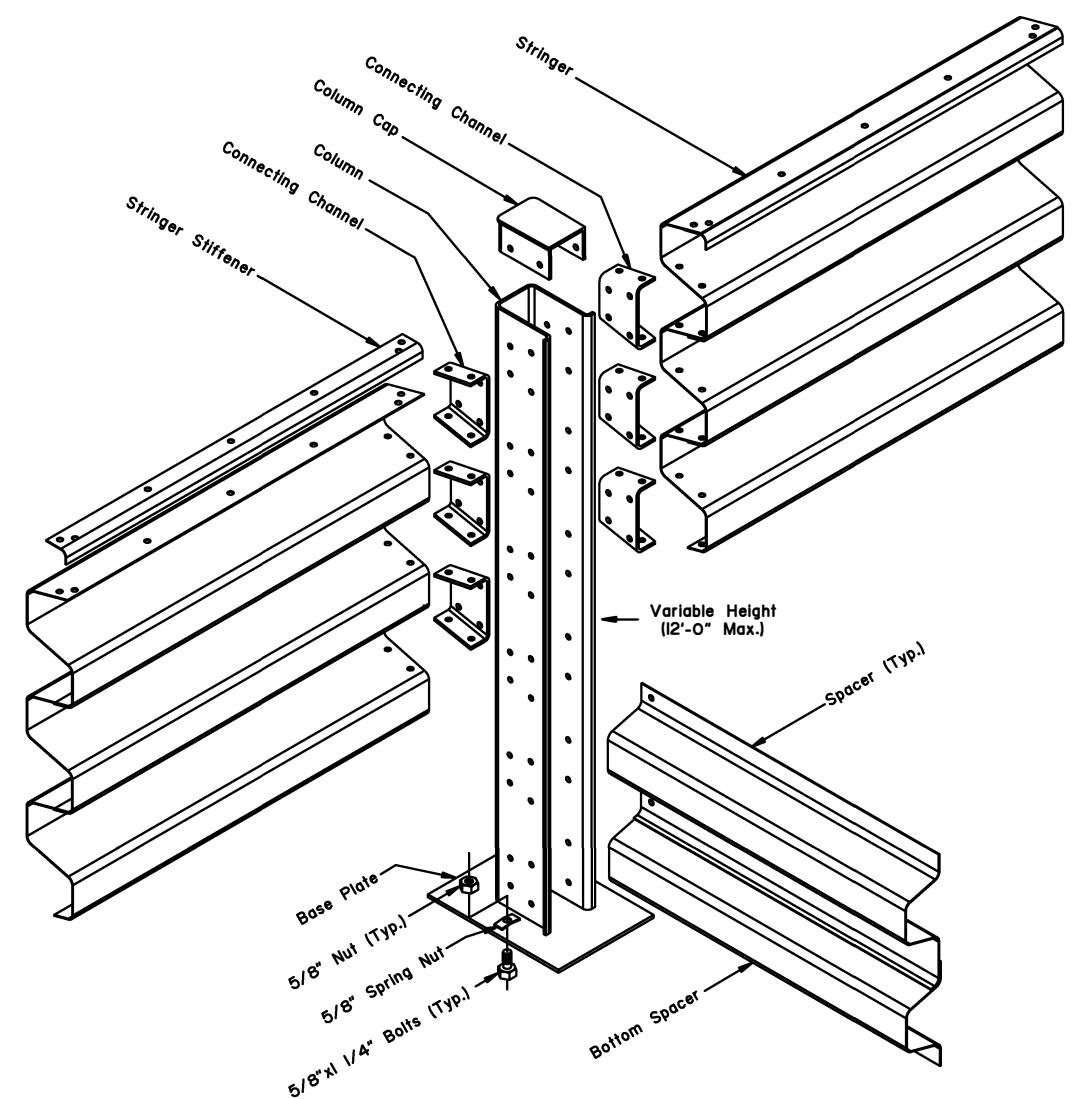

BIN WALL ASSEMBLY DETAILS

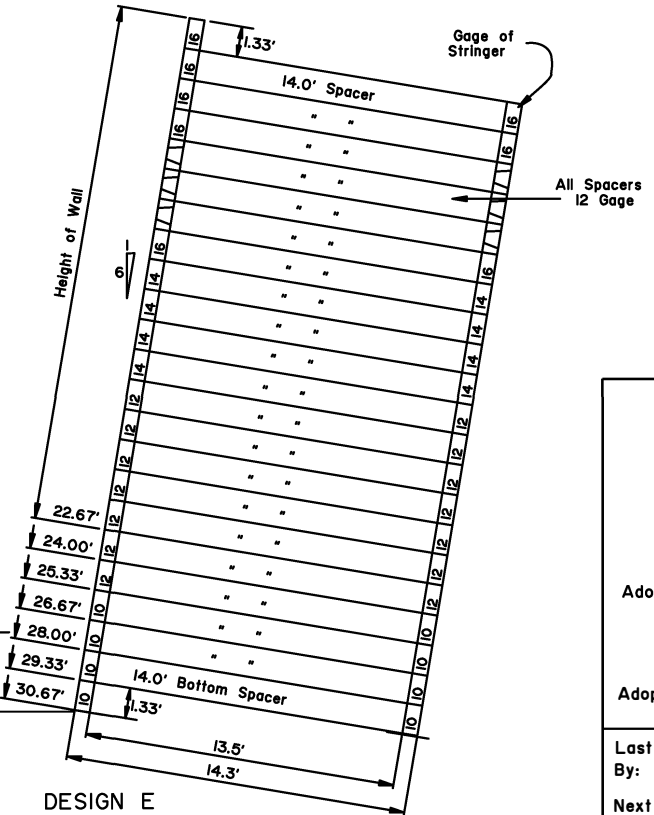
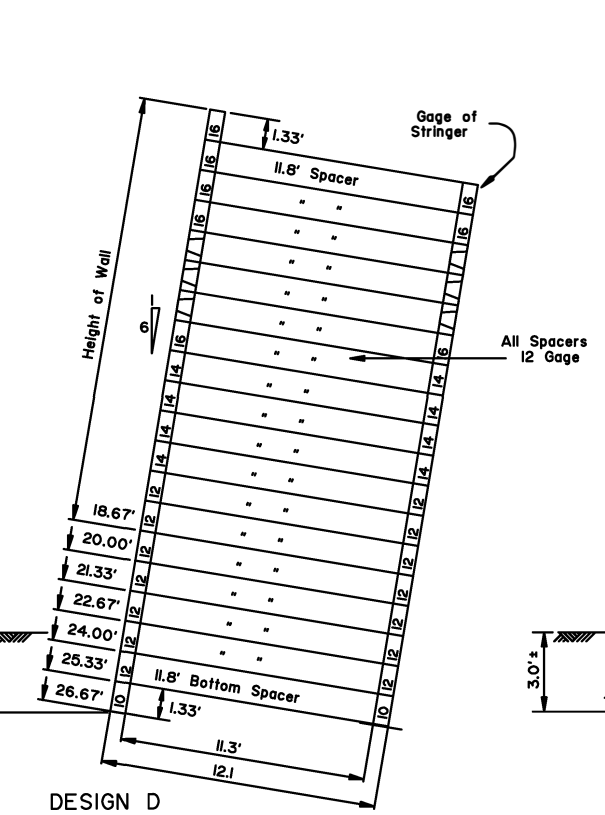
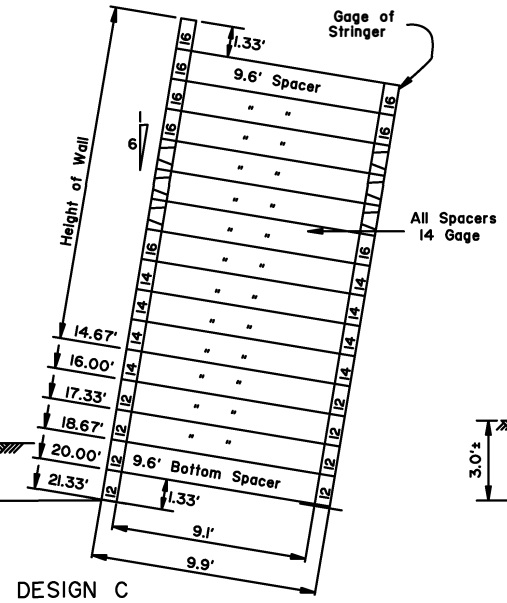
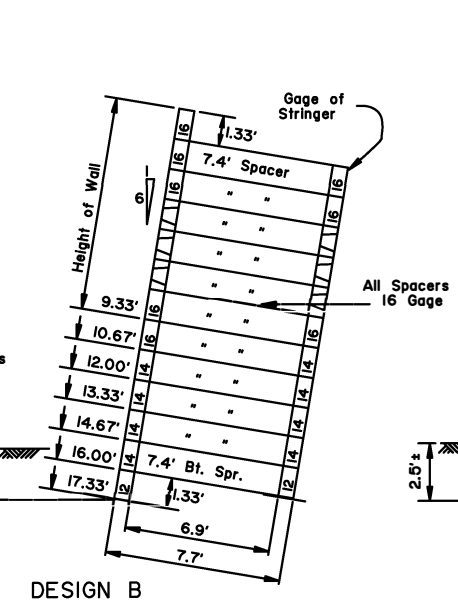
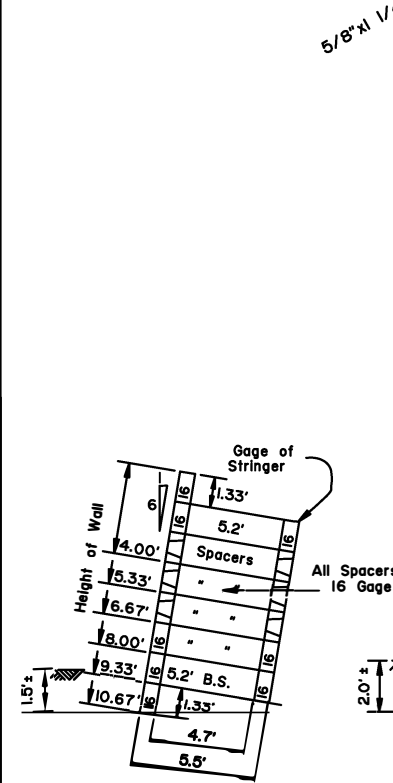
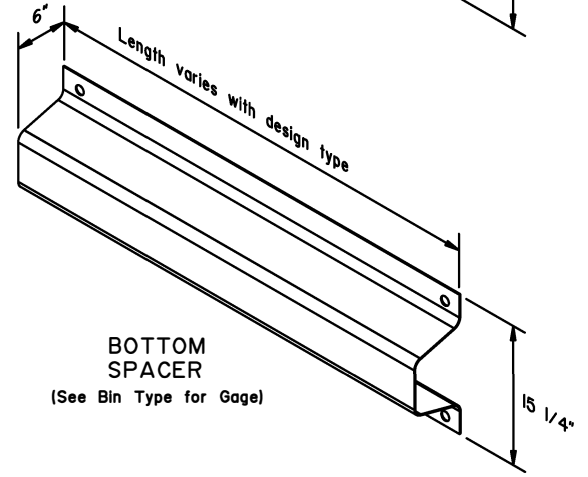
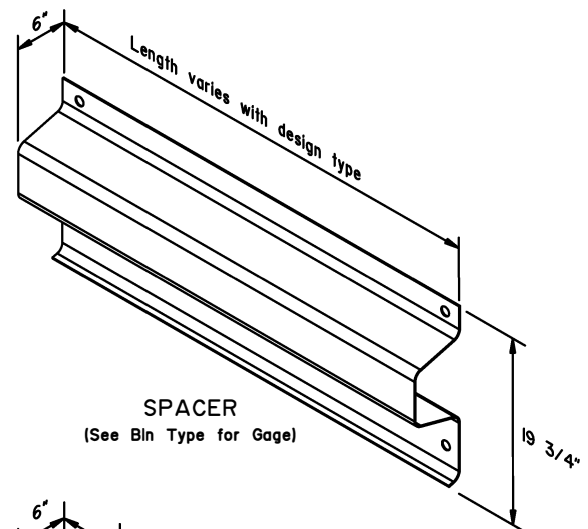
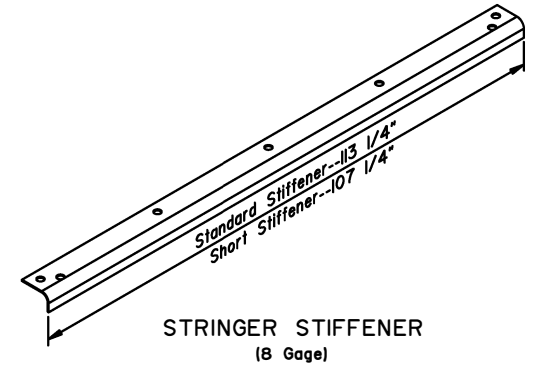
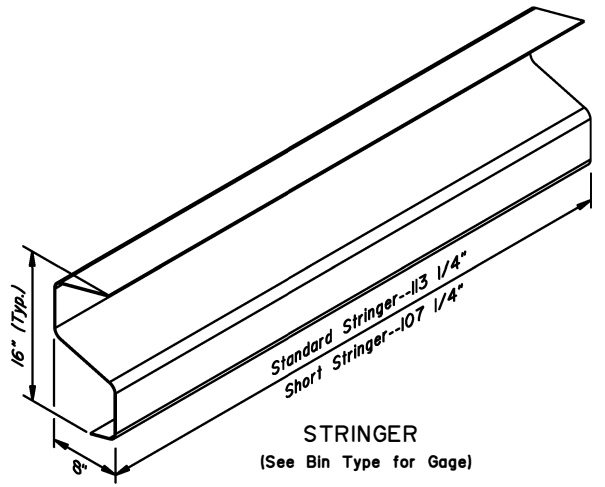

State of Alaska DOT&PF
ALASKA STANDARD PLAN

BIN WALLS

Adopted as an Alaska Standard Plan by: *Kenneth J. Fisher*
Kenneth J. Fisher, P.E.
Chief Engineer

Adoption Date: 02/08/2019

Last Code and Stds. Review By: Date:

Next Code and Standards Review date: 02/08/2029

GENERAL NOTES FOR TYPICAL APPLICATION DETAILS:

1. Only traffic control devices (TCD) for pedestrians are shown. Other TCD may be necessary to control vehicular traffic.
2. Provide longitudinal channelizing devices when sidewalks or pathways are closed to pedestrians and where required by the Plans or Specifications. When pre-construction project conditions are disrupted, closed, or relocated in a temporary traffic control zone, the temporary pedestrian accessible route (TPAR) shall be detectable and include accessibility features consistent with the features present in the existing pedestrian facility.
3. Typical applications details depicted on Sheets 1 through 3 are in order of preference. Avoid unnecessary pedestrian routing detours. Use Sheet 3 details only when it is not practical to use Sheet 1 or 2 details.
4. Place 4 feet (minimum) of longitudinal channelizing devices along each side of existing sidewalk prior to the work zone or pedestrian diversion.
5. Within the TPAR, existing and proposed TCD placements shall meet Standard Plan S-05. Existing and proposed TCD features mounted lower than 7 feet above the finished surface shall not project more than 4 inches for a length of 24 inches (maximum) into the TPAR. Reduced width of the TPAR shall be separated by 48 inches long (minimum) and 36 inches wide (minimum) segments. Construction materials shall not protrude into the useable width of the TPAR. When necessary to meet these requirements, use an approved temporary sign support.
6. Refer to sign size table on Sheet 4.

DIVERSION AWAY FROM ROADWAY TYPICAL APPLICATION DETAILS NOTES:

- A. Throughout the entire length of the TPAR diversion, maintain a minimum usable width of:
 - i) 48 inches when the existing pedestrian facility width is 48 inches or more.
 - ii) 36 inches when the existing pedestrian facility width is less than 48 inches.

If the TPAR diversion width is less than 60 inches, provide a 60 x 60-inch passing space at least every 200 feet to allow individuals in wheelchairs to pass. When it is not possible to maintain a minimum passing space, use an alternate route.

If the TPAR diversion grade exceeds 5%, construct a ramp as needed meeting the requirements of Section 405 of the 2006 ADA Standards for Transportation Facilities. The TPAR diversion when contained within the roadway right-of-way may have a grade exceeding 5% but must be less than or equal to the adjacent roadway grade.
- B. When a crosswalk is closed at signalized intersections, cover corresponding pedestrian traffic signal display(s).
- C. Where noted, install pedestrian signs on Type III barricades or longitudinal channelizing devices.

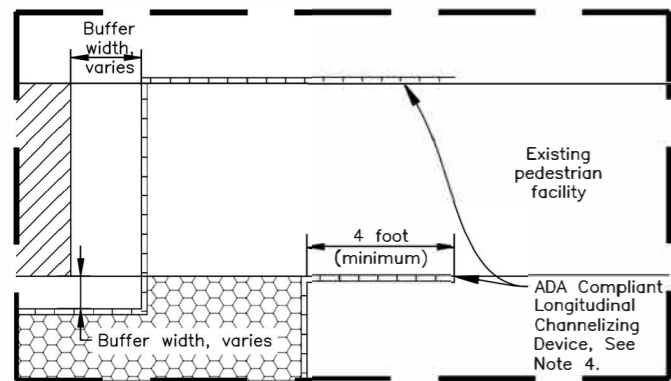

Inset "1"

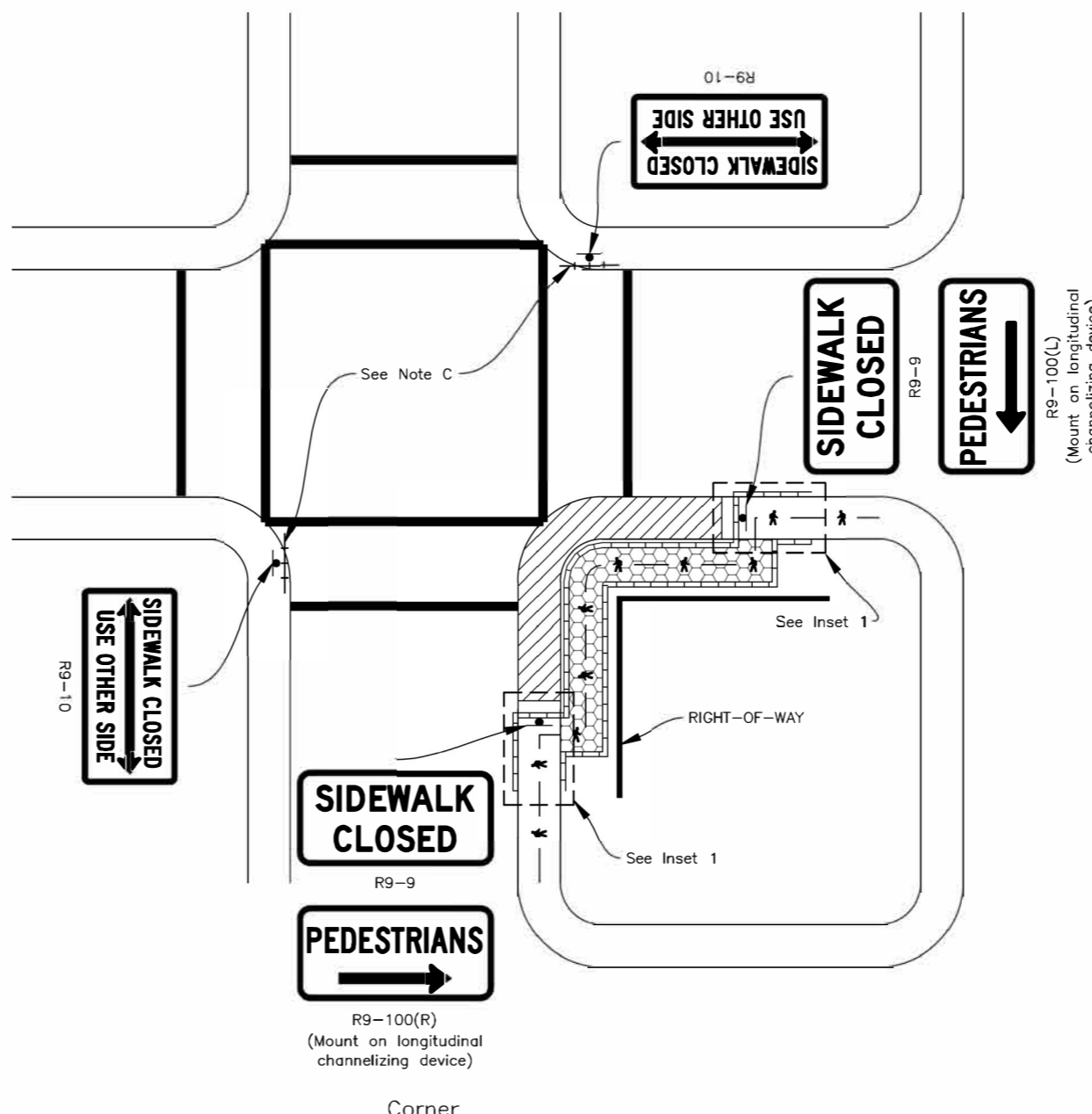

Corner

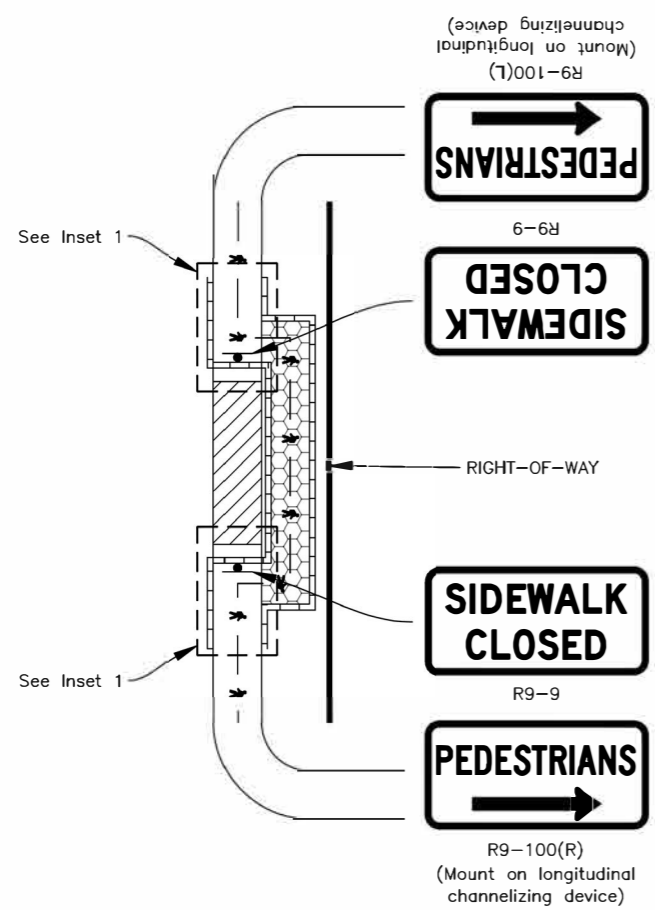

Mid-Block

**SIDEWALK, PATHWAY, OR SHOULDER CLOSURE:
DIVERSION AWAY FROM ROADWAY
TYPICAL APPLICATION DETAILS**

(If RIGHT-OF-WAY space available)

LEGEND:

	ADA Compliant Longitudinal Channelizing Device
	Temporary Pedestrian Accessible Route Diversion
	Temporary Pedestrian Accessible Route
	Work Zone
	Sign
	Type III Barricade

State of Alaska DOT&PF
ALASKA STANDARD PLAN
TEMPORARY PEDESTRIAN
ACCESSIBLE ROUTES

Adopted as an Alaska
Standard Plan by:
Lauren Little, P.E.
Interim Chief Engineer

Adoption Date: 01/29/2024

Last Code and Stds. Review
By: ZSH Date: 12/18/2023

Next Code and Standards Review Date: 12/18/2033

C-03.30

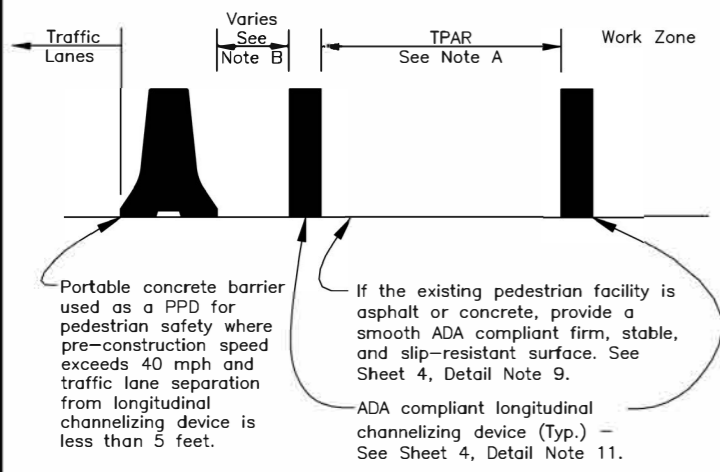

PEDESTRIAN DIVERSION TYPICAL SECTION

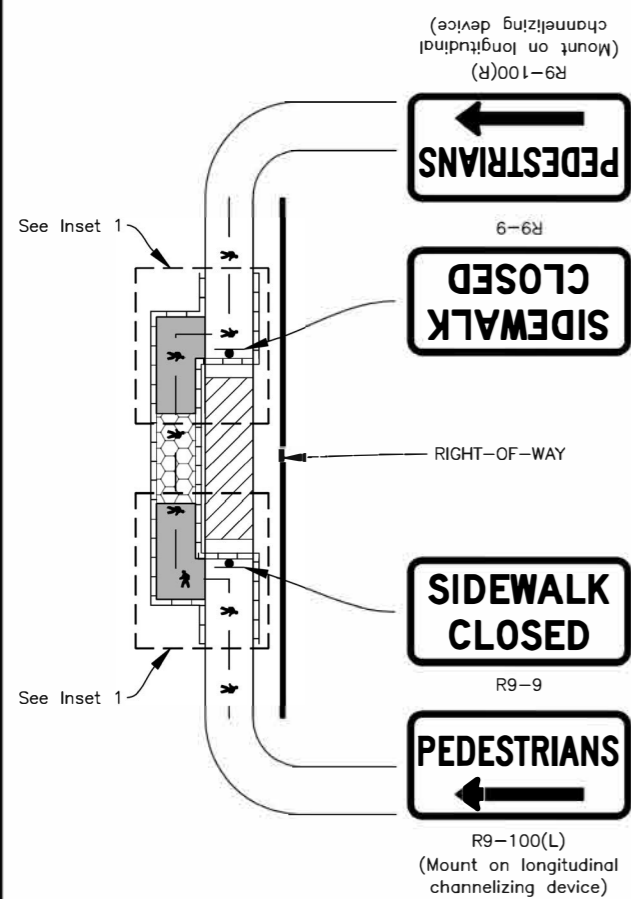

Mid-Block

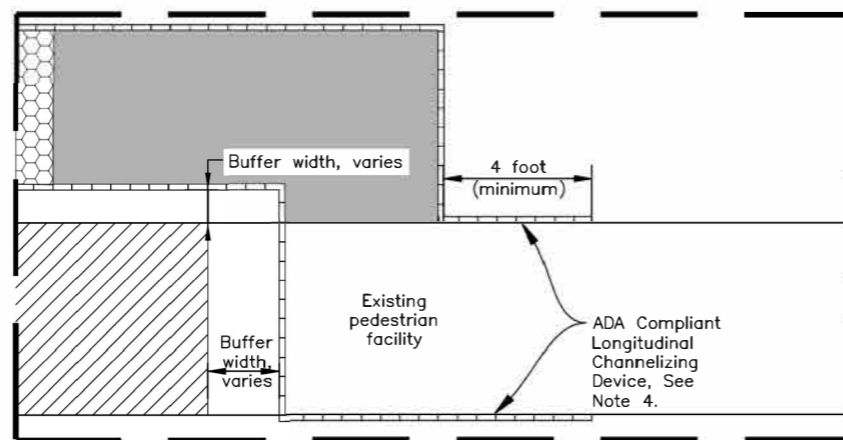

Inset "1"

SIDEWALK, PATHWAY, OR SHOULDER CLOSURE:
DIVERSION IN ROADWAY
TYPICAL APPLICATION DETAILS

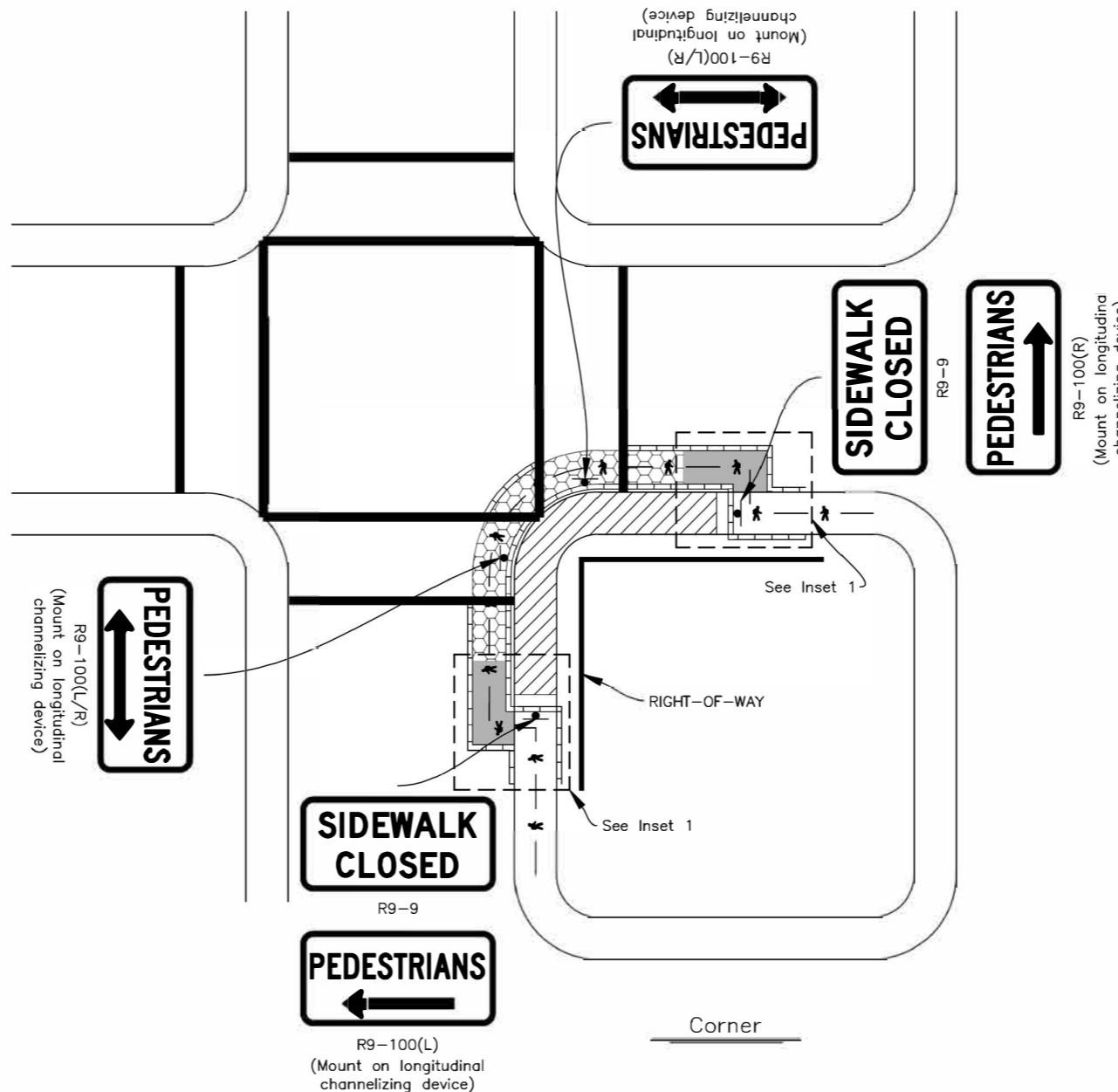

LEGEND:

	ADA Compliant Longitudinal Channelizing Device
	Temporary Pedestrian Accessible Route Diversion
	Temporary Pedestrian Accessible Route
	Work Zone
	Sign
	Temporary Curb Ramp (See Note C)

GENERAL NOTES FOR TYPICAL APPLICATION DETAILS:

1. Only traffic control devices (TCD) for pedestrians are shown. Other TCD may be necessary to control vehicular traffic.
2. Provide longitudinal channelizing devices when sidewalks or pathways are closed to pedestrians and where required by the Plans or Specifications. When pre-construction project conditions are disrupted, closed, or relocated in a temporary traffic control zone, the temporary pedestrian accessible route (TPAR) shall be detectable and include accessibility features consistent with the features present in the existing pedestrian facility.
3. Typical applications details depicted on Sheets 1 through 3 are in order of preference. Avoid unnecessary pedestrian routing detours. Use Sheet 3 details only when it is not practical to use Sheet 1 or 2 details.
4. Place 4 feet (minimum) of longitudinal channelizing devices along each side of existing sidewalk prior to the work zone or pedestrian diversion.
5. Within the TPAP, existing and proposed TCD placements shall meet Standard Plan S-05. Existing and proposed TCD features mounted lower than 7 feet above the finished surface shall not project more than 4 inches for a length of 24 inches (maximum) into the TPAP. Reduced width of the TPAP shall be separated by 48 inches long (minimum) and 36 inches wide (minimum) segments. Construction materials shall not protrude into the useable width of the TPAP. When necessary to meet these requirements, use an approved temporary sign support.
6. Refer to sign size table on Sheet 4.

DIVERSION IN ROADWAY TYPICAL APPLICATION DETAILS NOTES:

- A. Throughout the entire length of the TPAP diversion, maintain a minimum usable width of:
- i) 48 inches when the existing pedestrian facility width is 48 inches or more.
 - ii) 36 inches when the existing pedestrian facility width is less than 48 inches.

If the TPAP diversion width is less than 60 inches, provide a 60 x 60-inch passing space at least every 200 feet to allow individuals in wheelchairs to pass. When it is not possible to maintain a minimum passing space, use an alternate route.

If the TPAP diversion grade exceeds 5%, construct a ramp as needed meeting the requirements of Section 405 of the 2006 ADA Standards for Transportation Facilities.

- B. Where the pre-construction posted speed limit exceeds 40 mph, separate the longitudinal channelizing devices from the traffic lane by at least 5 feet. Where that is not feasible, install portable concrete barriers as a positive protection device (PPD) between the longitudinal channelizing devices and the traffic lane, meeting the deflection buffer requirements stated on Standard Plan G-47. See pedestrian diversion typical section.

- C. Place or construct temporary curb ramp as needed. Curb ramp must meet ADA requirements, see Sheet 4.

State of Alaska DOT&PF
ALASKA STANDARD PLAN
TEMPORARY PEDESTRIAN
ACCESSIBLE ROUTES

Adopted as an Alaska
Standard Plan by:
Lauren Little, P.E.
Interim Chief Engineer

Adoption Date: 01/29/2024

Last Code and Sds. Review
By: ZSH Date: 12/18/2023

Next Code and Standards Review Date: 12/18/2033

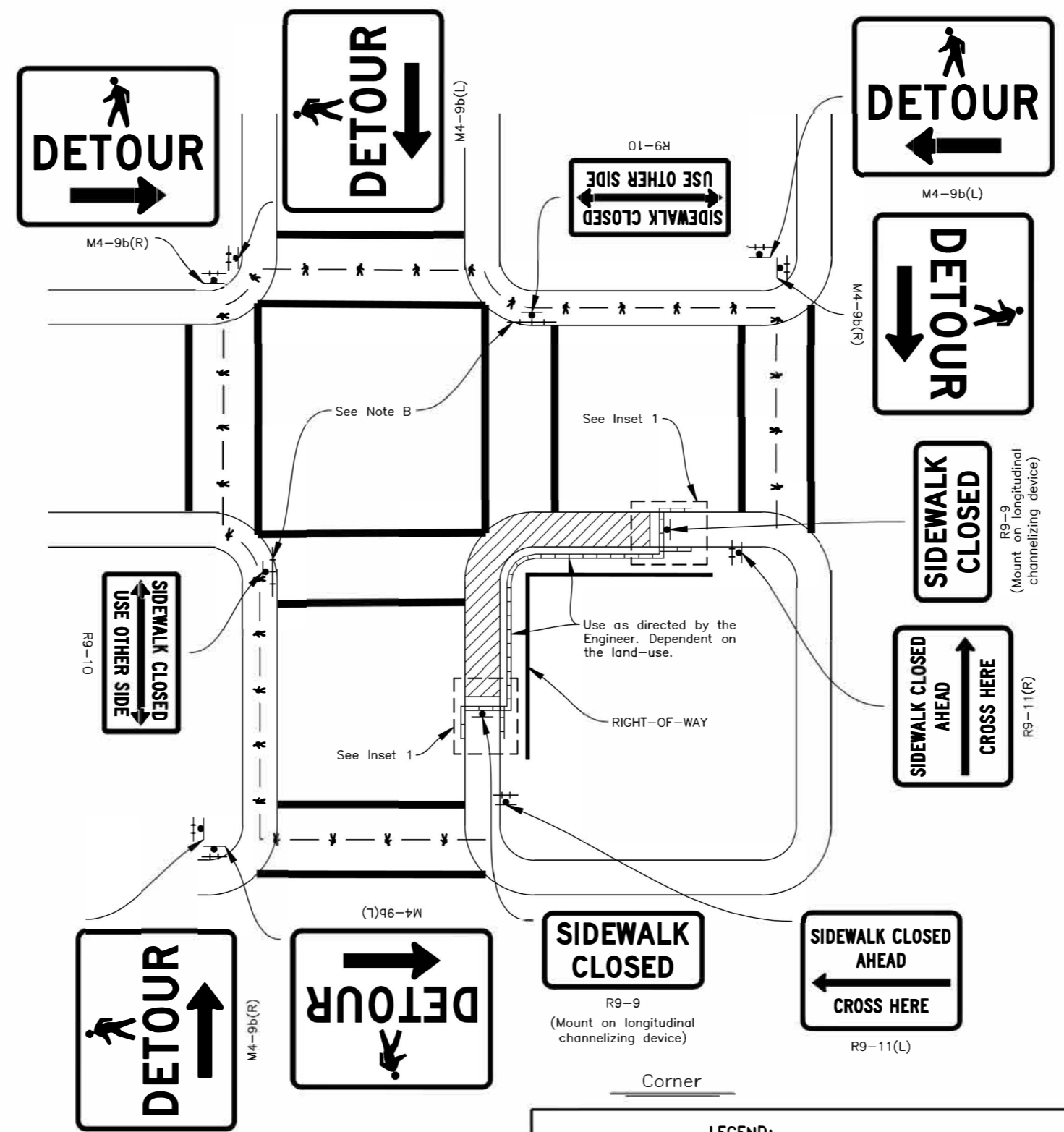
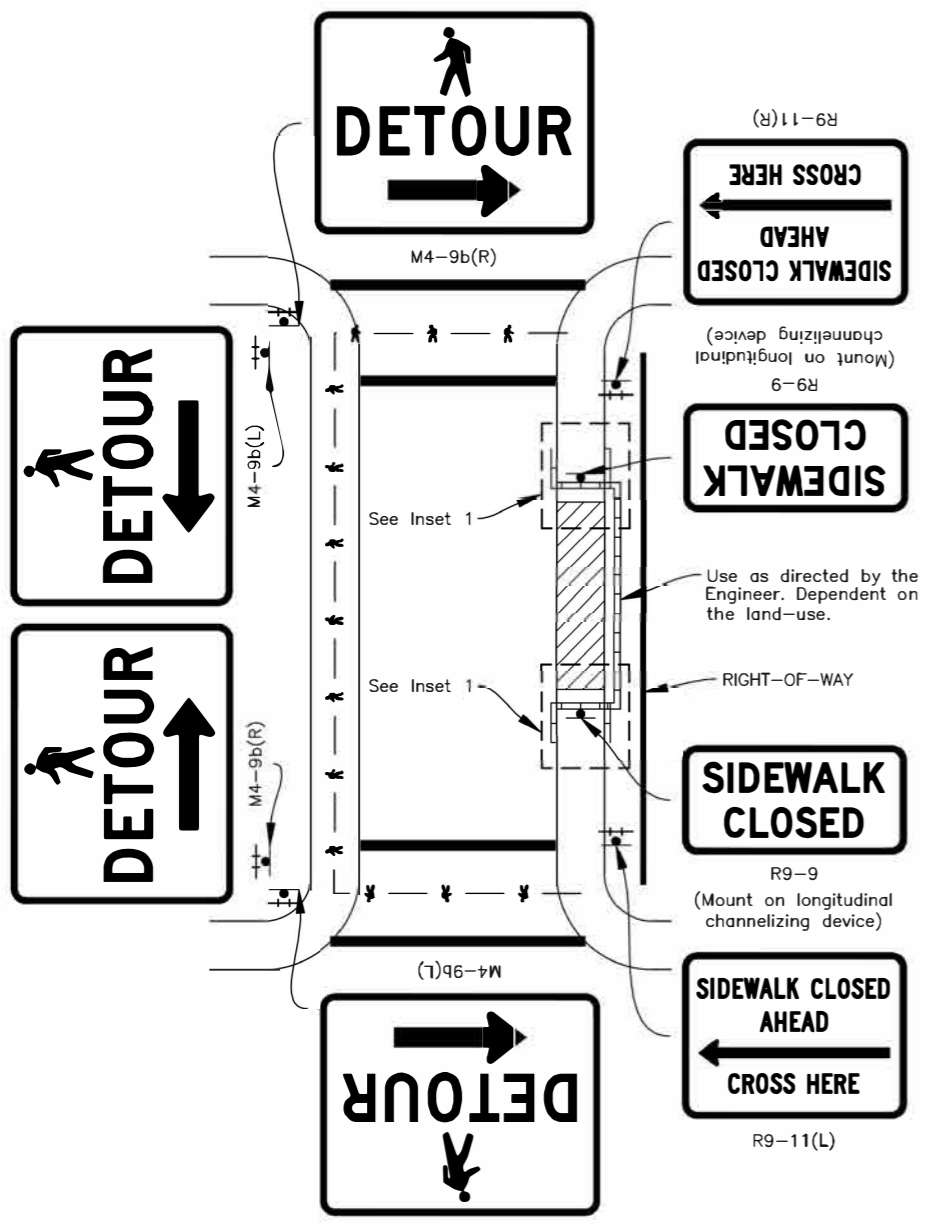
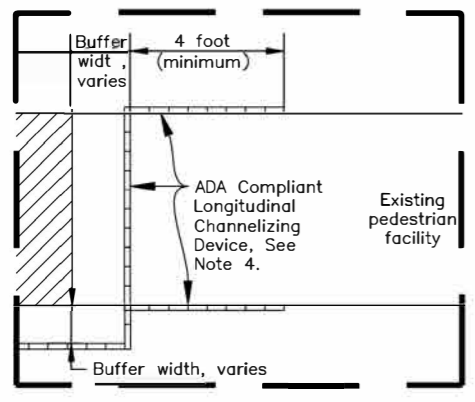

SIDEWALK, PATHWAY, OR SHOULDER CLOSURE:
DETOUR ACROSS ROADWAY
TYPICAL APPLICATION DETAILS

GENERAL NOTES FOR TYPICAL APPLICATION DETAILS:

1. Only traffic control devices (TCD) for pedestrians are shown. Other TCD may be necessary to control vehicular traffic.
2. Provide longitudinal channelizing devices when sidewalks or pathways are closed to pedestrians and where required by the Plans or Specifications. When pre-construction project conditions are disrupted, closed, or relocated in a temporary traffic control zone, the temporary pedestrian accessible route (TPAR) shall be detectable and include accessibility features consistent with the features present in the existing pedestrian facility.
3. Typical applications details depicted on Sheets 1 through 3 are in order of preference. Avoid unnecessary pedestrian routing detours. Use Sheet 3 details only when it is not practical to use Sheet 1 or 2 details.
4. Place 4 feet (minimum) of longitudinal channelizing devices along each side of existing sidewalk prior to the work zone or pedestrian diversion.
5. Within the TPAR, existing and proposed TCD placements shall meet Standard Plan S-05. Existing and proposed TCD features mounted lower than 7 feet above the finished surface shall not project more than 4 inches for a length of 24 inches (maximum) into the TPAR. Reduced width of the TPAR shall be separated by 48 inches long (minimum) and 36 inches wide (minimum) segments. Construction materials shall not protrude into the useable width of the TPAR. When necessary to meet these requirements, use an approved temporary sign support.
6. Refer to sign size table on Sheet 4.

DETOUR ACROSS ROADWAY TYPICAL APPLICATION DETAILS NOTES:

- A. When a crosswalk is closed at signalized intersections, cover corresponding pedestrian traffic signal display(s).
- B. Where noted, install pedestrian signs on Type III barricades or longitudinal channelizing devices.
- C. Route pedestrians to the safest and closest crossing point near the work zone.
- D. Limit work to one corner at a time to minimize pedestrian disruption and detour length.

LEGEND:

	ADA Compliant Longitudinal Channelizing Device
	Temporary Pedestrian Accessible Route Diversion
	Temporary Pedestrian Accessible Route
	Work Zone
	Sign
	Type II Barricade
	Type III Barricade

State of Alaska DOT&PF
ALASKA STANDARD PLAN
TEMPORARY PEDESTRIAN
ACCESSIBLE ROUTES

Adopted as an Alaska Standard Plan by:
Lauren Little, P.E.
Interim Chief Engineer

Adoption Date: 01/29/2024

Last Code and Stds. Review
By: ZSH Date: 12/18/2023

Next Code and Standards Review Date: 12/18/2033

C-03.30

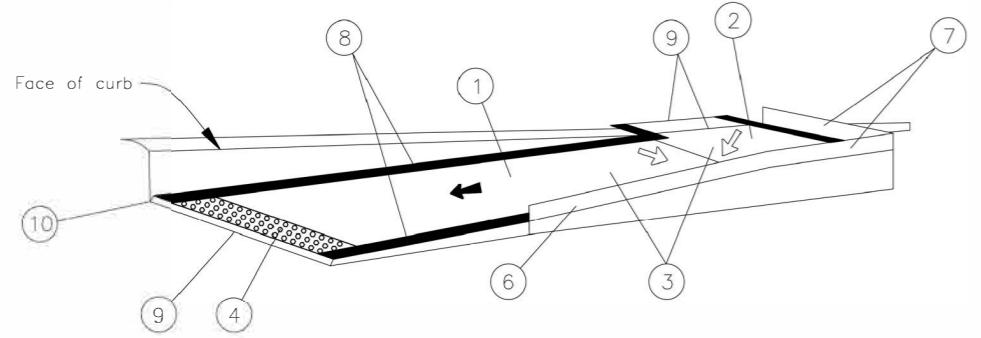

EXAMPLE TEMPORARY CURB RAMP, PARALLEL TO CURB

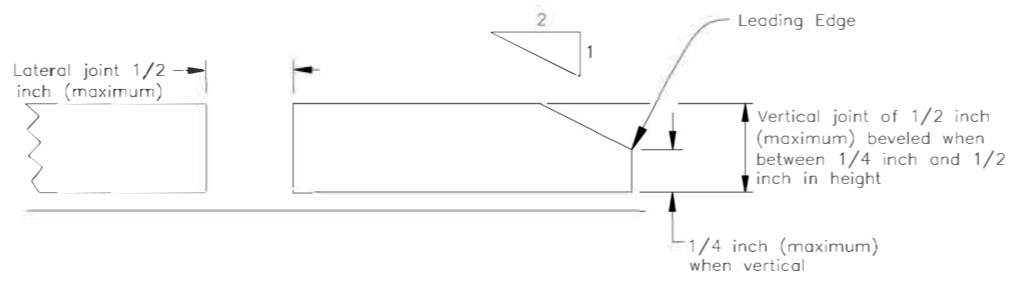

EDGE TREATMENT DETAIL

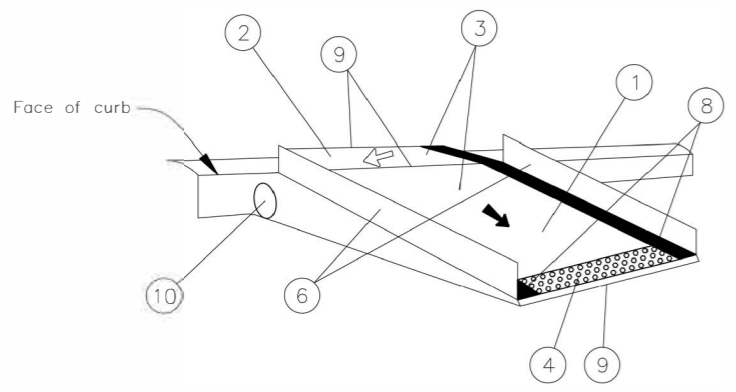

With Protective Edge

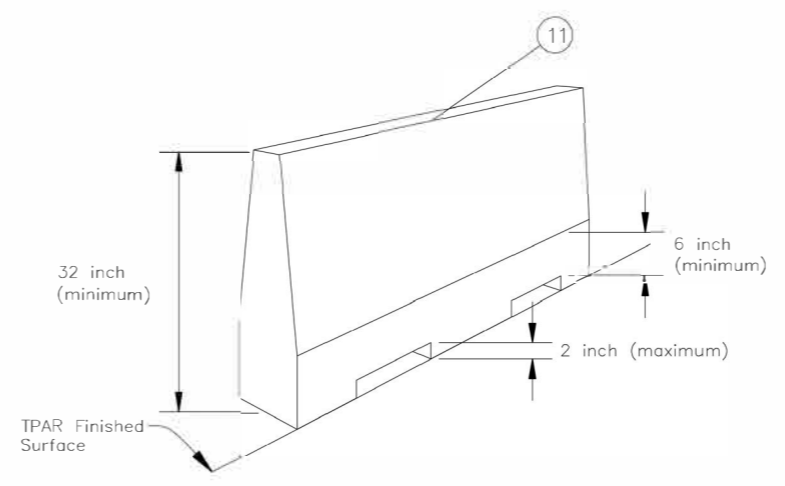

EXAMPLE LONGITUDINAL CHANNELIZING DEVICE DETAIL

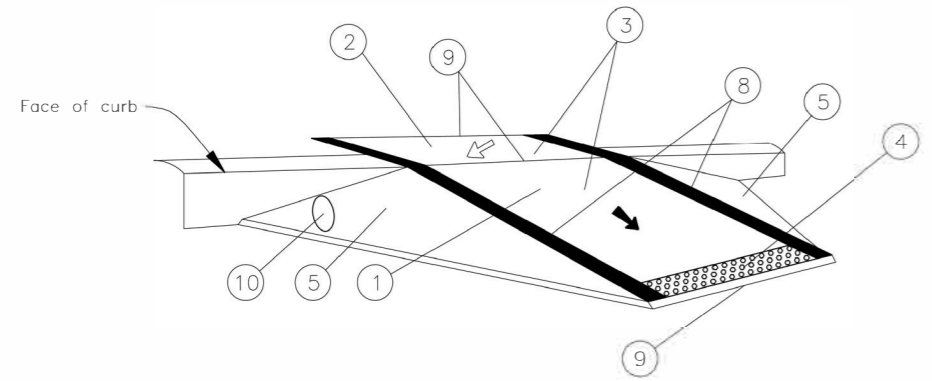

With Side Flares

Detectable edging are not required when meeting the requirements of Detail Note 6

EXAMPLE TEMPORARY CURB RAMP, PERPENDICULAR TO CURB

GENERAL NOTES:

1. The curb ramp shall be either self-ballasting or include an anchoring system capable of keeping the platform stationary under pedestrian traffic, including motorized wheelchairs.
2. The curb ramp platform shall be free of sharp, rough edges, or abrasive elements that may harm pedestrians.

DETAIL NOTES:

- 1 Clear width per requirements stated in sheets 1 and 2, Note A.
- 2 Landing shall be provided at the top of curb ramps. The landing clear length shall be 36 inches minimum. The landing clear width shall be at least as wide as the curb ramp (excluding flared sides, leading to the landing).
- 3 Ramps shall have a running slope of 8.3% maximum (7.7% nominal) and cross slope of 2.0% maximum (1.5% nominal). If the landing functions as a turning space, slope in any direction (including diagonal) of the turning space shall be 2.0% maximum (1.5% nominal).
- 4 Install detectable warning surface at pedestrian street crossings. The detectable warning shall extend the full width of the curb ramp (excluding flared sides) and shall be 24 inches (minimum) deep measured from the back of the curb on the ramp surface. Omit detectable warning surfaces at end of sidewalk transitions that are not at a crosswalk.
- 5 Curb ramp flares where provided shall have 10% maximum (8.3% nominal) slope.
- 6 Detectable edging with 6 inch (minimum) height shall be placed along the ramp run when there is a vertical drop exceeding 6 inches or is adjacent to a side slope exceeding 1:3 (vertical:horizontal).
- 7 Detectable edging with 6 inch (minimum) height and contrasting color shall be placed on all turning spaces where the walkway changes direction.
- 8 The curb ramp walkway edge shall be marked with a contrasting color, 4 inch wide stripe. The marking is optional where a contrasting detectable edging is used.
- 9 See edge treatment detail for requirements on lateral and vertical joints or gaps between surfaces. Surface slopes that meet at a grade break shall be flush.
- 10 Provide an approved means to maintain water flow along existing curb flow line and to prevent water from accumulating at the bottom of the ramp, or overflowing onto the ramp surface.
- 11 Where longitudinal channelizing devices are used to delineate a TPAR, continuous detectable top and bottom surfaces in compliance with the Alaska Traffic Manual shall be provided such that pedestrians using a long cane can follow it. The top of the top surface shall be at least 32 inches above the TPAR surface. The bottom surface shall be at least 6 inches in height with a gap no greater than 2 inches above the TPAR surface. Longitudinal channelizing devices shall be interlocked and not have gaps that allow pedestrians to stray from the channelizing path.

SIGN SIZE TABLE			
ALASKA SIGN DESIGN SPECIFICATIONS CODE	SIZE H X V (INCHES)		
R9-9	24	X	12
R9-10	24	X	12
R9-100(L/R), R9-100(L), R9-100(R)	24	X	12
R9-11(L), R9-11(R)	24	X	18
M4-9b(L), M4-9b(R)	30	X	24

LEGEND:

Running slope
 Cross slope
 Detectable warning surface

State of Alaska DOT&PF
ALASKA STANDARD PLAN
TEMPORARY PEDESTRIAN ACCESSIBLE ROUTES

Adopted as an Alaska Standard Plan by:

Lauren Little, P.E.
Interim Chief Engineer

Adoption Date: 01/29/2024

Last Code and Sds. Review
By: ZSH Date: 12/18/2023

Next Code and Standards Review Date: 12/18/2033

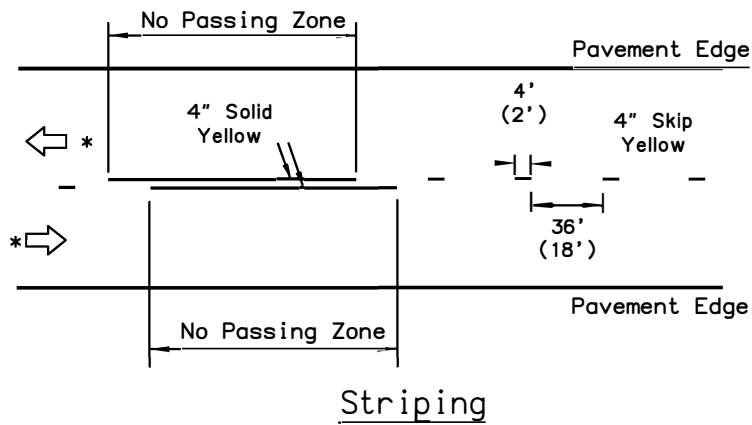

Striping

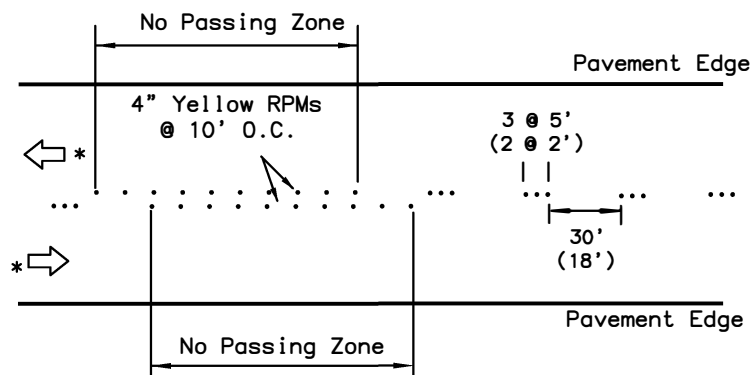

Temporary Raised Pavement Markers

DETAIL A

Two-lane road: No Passing Zones indicated with pavement markings.

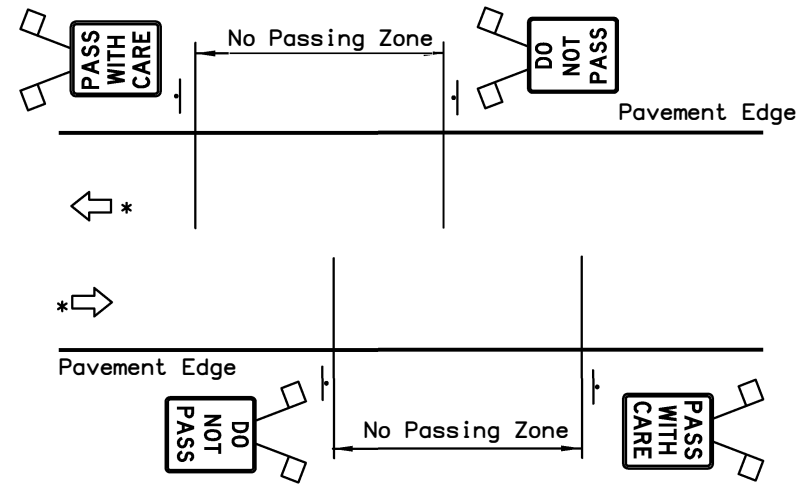

DETAIL C

Two-lane road: No Passing Zones indicated by signs only (see Note 2c). No centerline delineation.

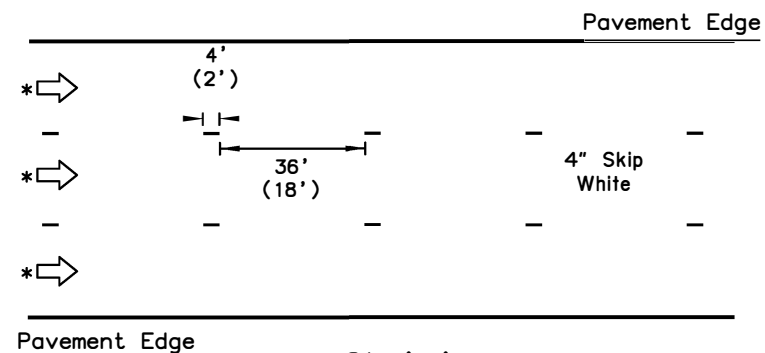

Striping

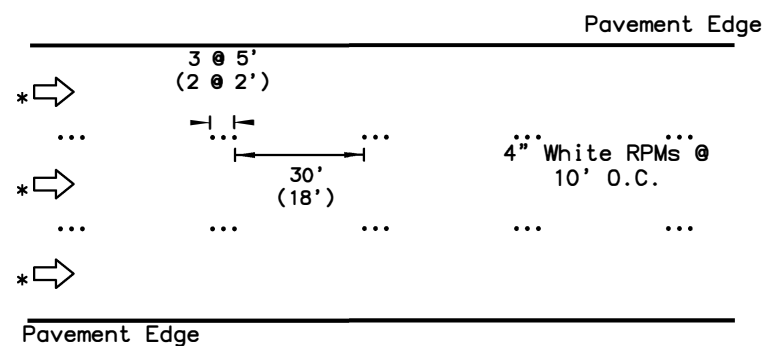

Temporary Raised Pavement Markers

DETAIL D

Multilane one-way road: Lane dividing lines

* Direction of Travel

GENERAL NOTES:

- Final pavement markings conforming to Part 3 of the Alaska Traffic Manual should be installed before paved roads are open to public travel. If that is not practical, install interim pavement markings as shown on this drawing. Maintain interim pavement markings until final pavement markings are installed.
- No interim pavement markings are required:
 - on projects that will not have permanent markings when finished.
 - in work zones that are open to public travel for no more than one work shift during daytime or for no more than one hour at night.
 - where DO NOT PASS and PASS WITH CARE signs are installed on two lane roads as shown in Detail C, no pavement markings are required:
 - for 3 days if seasonal ADT is above 2000, or
 - for 1 month if seasonal ADT is below 2000.
- Interim pavement markings should not be in place longer than 14 calendar days before being replaced with permanent markings conforming to Part 3 of the Alaska Traffic Manual unless the Engineer provides written approval.
- Where R4-1 DO NOT PASS signs are used, install at the beginning of no passing zones and at no more than 1500' spacings within no passing zones.
- Install high level warning devices on all DO NOT PASS and PASS WITH CARE signs.
- Offset temporary markings 8"-12" from the future location of permanent markings if applied on the same lift of pavement.
- Dimensions in parenthesis apply to curves with a radius of 1000 feet or less or where posted speed limit is 30 mph or less.

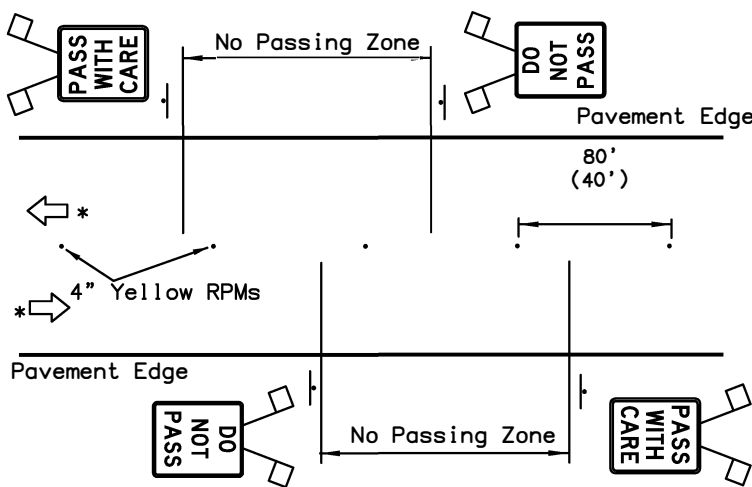

DETAIL B

Two-lane road: No Passing Zones indicated by signs only. Raised pavement markers for centerline delineation.

State of Alaska DOT&PF
ALASKA STANDARD PLAN
INTERIM
PAVEMENT MARKINGS

Adopted as an Alaska Standard Plan by: *Kenneth J. Fisher*
Kenneth J. Fisher, P.E.
Chief Engineer

Adoption Date: 02/08/2019

Last Code and Stds. Review By: Date:

Next Code and Standards Review date: 02/08/2029

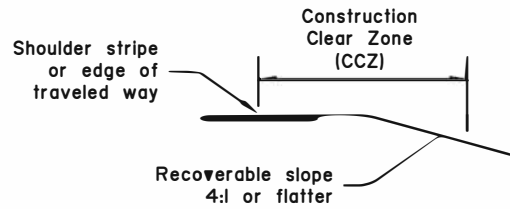

FIGURE 1

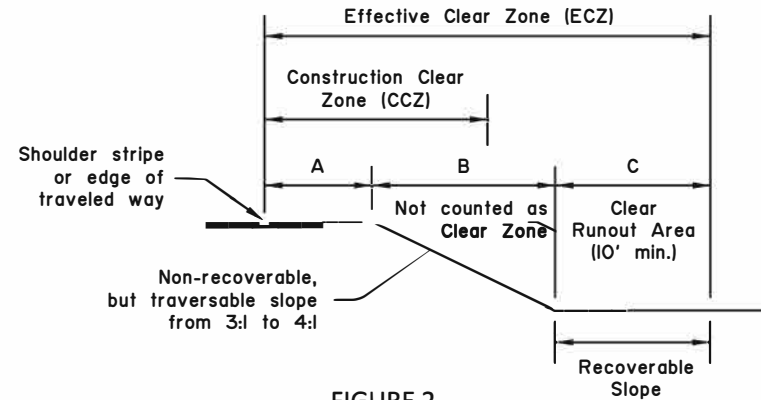

FIGURE 2

Table 1 - Width of Construction Clear Zone (feet)

Hazard	AADT	Posted Speed Limit (MPH)							
		<=30 MPH		35 to 40 MPH		45 to 55 MPH		>=60 MPH	
		6:1 or flatter	5:1 to 4:1	6:1 or flatter	5:1 to 4:1	6:1 or flatter	5:1 to 4:1	6:1 or flatter	5:1 to 4:1
Fill (Fore) & Cut (Back) Slopes	Under 750	5'	5'	6'	8'	8'	12'	12'	16'
	750 - 6,000	6'	10'	8'	12'	14'	18'	20'	26'
	Over 6,000	10'	10'	12'	14'	16'	20'	22'	28'
Fixed Objects	All	15'		30'					

Table 2 - Treatment for Hazards Within Construction Clear Zone

Roadside Condition to be Treated	Category	Treatment
Fill (Fore) Slopes, including trenches	Steeper than 3:1 or water 3 ft. or deeper	Use Table 5 to select from the following two options: 1. Install rigid barrier or guardrail if the condition warrants barrier, or 2. Use drums or Type II barricades if the condition does not warrant barrier.
	3:1 to 4:1	1. Use drums or Type II barricades if 10 ft. of runout at the bottom of the slope is not clear of obstructions. 2. No traffic control devices are required if 10 ft. of runout at the bottom of the slope is clear of obstructions. 3. If water 3 ft. or deeper is at bottom of slope, use Table 5.
	Flatter than 4:1	No traffic control devices are required, except when water 3 ft. or deeper is in construction clear zone use Table 5.
Fixed Objects	All	Install rigid barrier or guardrail if called for by the plans or specifications. Otherwise use SSHC Section 643-3.04.3 - Fixed Objects.

GENERAL NOTES:

- The "Construction Clear Zone" (CCZ) may be called "Work Zone Clear Zone" or "Clear Zone in Work Zones" in other publications.
- In the case of conflicts, this Standard Plan has lesser precedence than Section 643 (Traffic Maintenance) of the Standard Specifications for Highway Construction (SSHC).
- During seasonal shutdown or if construction activity is scheduled for suspension for 45 days or more, treat hazards within a 30 foot CCZ width or within the permanent design clear zone (CZ) width.
- These guidelines are not comprehensive and are not intended to limit the use of safety measures.
- During pilot car operations, keep fixed objects and other hazards, 2 feet or farther, away from the edge of traveled way and delineate with channelizing devices as required by the Engineer.

INSTRUCTIONS FOR USING TABLES 1 THROUGH 5:

Use The following tables to determine how to treat roadside fixed object or slopes (including trenches, berms and material stockpiles) in construction clear zones.

TABLE 1: Use to determine whether the hazard is within the CCZ

TABLE 2: Use to determine the appropriate treatment for hazards within the CCZ. No treatment is required for fixed objects or slopes outside the CCZ.

TABLES 3a and 3b: Use to determine appropriate treatment for pavement edge dropoffs.

TABLE 4: Use to determine barrier flare rates.

TABLE 5: Use to determine whether drums or Type II barricades, or temporary barrier or guardrail, are required on fill slopes or for water hazards.

TABLE 1 NOTES:

- Measure CCZ from the shoulder stripe. If there is no shoulder stripe, measure from the edge of the traveled way. See Figure 1.
- If CCZ include or ends on a slope of 3:1 to 4:1, use the Effective Clear Zone (ECZ) that extends beyond the bottom of the slope to provide a clear runout area of 10 foot minimum width. The ECZ width must equal or greater than the CCZ width from Table 1. See Figure 2 and verify that A+C ≥ CCA and C ≥ 10 feet.
- If a CCZ includes or ends on a slope steeper than 3:1, the top of slope must be delineated by channelizing devices or protected by barrier.
- The term "fixed objects" is defined in Section 643-1.02 of the SSHC.
- AADT stands for Average Annual Daily Traffic. Use the higher of the as listed in the plans or the average of June/July/August ADT's, unless otherwise specified by the Engineer.

TABLE 2 NOTES:

- Eliminate non-traversable slopes (those steeper than 3:1) and fixed objects (as defined in Section 643-1.02 of the SSHC) within the CCZ when practicable. They should only be left in place and treated as shown in this table when elimination is not practicable.
- Maintain a 2-foot minimum wide lateral buffer space between the edge of traveled way and work areas. This provides an area to install barriers or other delineation by channelizing devices.
- If necessary to treat multiple hazards on the same road segment (slopes and fixed objects), choose treatments from Table 2 that satisfy the requirements for the most significant of the multiple hazards.

State of Alaska DOT&PF
ALASKA STANDARD PLAN

ROADSIDE SAFETY TREATMENT
FOR WORK ZONES

Adopted as an Alaska Standard Plan by: *Carolyn A. Morehouse*
Carolyn Morehouse, P.E.
Chief Engineer

Adoption Date: 09/15/2022

Last Code and Stds. Review
By: LRG Date: 09/15/2022

Next Code and Standards Review date: 09/15/2032



FIGURE 3
Pavement Drop-off Detail



FIGURE 4
Safety Edge Detail

TABLE 3 NOTES:

1. This table applies to pavement edge drop-offs that are adjacent to traffic and left after the pavement shift ends and for posted speeds > 30 mph. Use engineering judgment for edge treatment for posted speeds ≤ 30 mph.
2. Use interim pavement markings and signs as required according to Standard Plan C-05 (for all conditions).
3. A Safety Edge is a formed pavement edge taper sloped at approximately 30°, but not more than 35° from horizontal.
4. Use a Safety Edge for longitudinal or diagonal pavement edge drop-offs more than 2 inches within a traveled lane. See Figure 3. Use a Safety Edge on longitudinal joints between lanes as required by Table 3a.
5. The "Across Active Lane, and Entrance and Exit Ramps" column applies to any location where motorists will cross pavement drop-offs (includes transverse construction joints) at an acute angle (45° or more). Taper may be reduced to 6:1 at posted speeds of 30 mph or less.
6. Signage applies to all posted speed for edge drop-offs as shown in Table 3a. For information on signs and locations, see SSHC Section 643-3.04 and the Alaska Traffic Manual (ATM). Signs should be placed at the beginning and end points of each paved segment, and in locations between as specified. Also, see Table 3b.
7. "Channelizing Devices" means drums with steady-burn lights, candle, or cones.
8. Treatment for pavement edge drop-offs are in addition to Treatment for Hazards within Construction Clear Zones (CCZs) (i.e. fixed obstacle or slope protection may also be required).

BARRIER TERMINATION AND TABLE 4 NOTES:

1. Terminate portable rigid barrier (concrete or metal) with one of the following methods:
 - a) An NCHRP 350 or MASH TL-3 approved end treatment or crash cushion.
 - b) An NCHRP 350 or MASH TL-3 approved buried-in-backslope treatment
 - c) A Thrie-Beam transition according to Std. Plan G-32 (except attached to a rigid barrier instead of a bridge rail) and terminated with a MASH TL-3 end treatment.
 - d) Terminate outside the CCZ by flaring barriers away from the roadway at the rate shown in Table 4 for rigid barriers (maximum 10:1 cross slope in front of the barrier).
 - e) Sloped ends may be used to terminate barriers within the CZ when the regulatory (black on white sign) speed limit is 30 mph or below. For speeds more than 30 mph, the Engineer may approve sloped ends if they determine NCHRP 350 or MASH compliant end treatments are impracticable. See Std. Plan G-46 for concrete barrier sloped ends.
2. Terminate temporary W-Beam guardrail with one of the following methods:
 - a. With a MASH TL-3 approved end treatment
 - b. By burying it in a backslope according to Std. Plan G-16
 - c. By flaring the guardrail away from the road at the rate shown in Table 4 for semi-rigid barriers (maximum 10:1 cross slope in front of the guardrail).
 - d. Terminate outside the CZ.

Nominal Lift Thickness / Height of Pavement Edge Drop-off	Between Active Lanes of traffic moving in same direction	Between Active Lanes of traffic moving in opposing directions	Outside Pavement Edge (if within 3' of traveled way)	Outside Pavement Edge if more than 3' from traveled way and within the CCZ	Across Active Lane, and Entrance and Exit Ramps
0 to 1.0"	No Edge Treatment or Signage Required				
More than 1.0" to 2.0"	UNEVEN LANE Signs		LOW SHOULDER Signs		
More than 2.0" to 3.0"	UNEVEN LANES Signs - Use Channelizing Devices or Safety Edge	UNEVEN LANES Signs - Use Channelizing Devices	LOW SHOULDER Signs - Use Channelizing Devices - Consider Safety Edge	LOW SHOULDER Signs	Taper Drop-off at slope of 15H:1V or flatter Use BUMP Sign
More than 3.0" to 6.0"	UNEVEN LANES Signs - Use Channelizing Devices and Use Safety Edge	UNEVEN LANES Signs - Use Channelizing Devices	SHOULDER DROP OFF Signs - Use Channelizing Devices and Safety Edge; or Use Barrier	SHOULDER DROP OFF Signs - Use Channelizing Devices or Barrier	
More than 6"	Prohibited		Barrier - Installed on traffic side of drop-off	Channelizing Devices or Barrier according to Table 5	

Legend	Number	ATM * Ref.
UNEVEN LANES	W8-11	6F.45
LOW SHOULDER	W8-9	6F.44
SHOULDER DROP OFF (Symbol)	W8-17	6F.44
SHOULDER DROP OFF (Plaque)	W8-17P	6F.44
BUMP	W8-1	2C.28

* ATM = Alaska Traffic Manual

Speed (mph)	Flare Rate	
	Rigid	Semi-Rigid
70	20:1	15:1
60	18:1	14:1
55	16:1	12:1
50	14:1	11:1
45	12:1	10:1
40	10:1	8:1
30	8:1	7:1

State of Alaska DOT&PF
ALASKA STANDARD PLAN

**ROADSIDE SAFETY TREATMENT
FOR WORK ZONES**

Adopted as an Alaska Standard Plan by: *Carolyn A. Morehouse*
Carolyn Morehouse, P.E.
Chief Engineer

Adoption Date: 09/15/2022

Last Code and Stds. Review
By: LRG Date: 09/15/2022
Next Code and Standards Review date: 09/15/2032

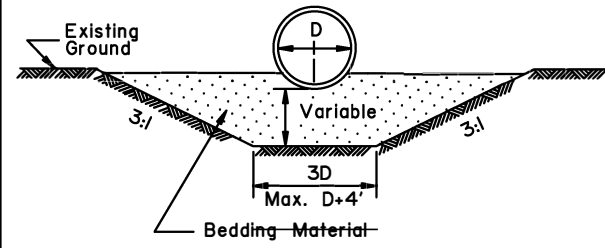

TYPE "A"
FOUNDATION STABILIZATION
To be used in unstable areas as directed by the Engineer.

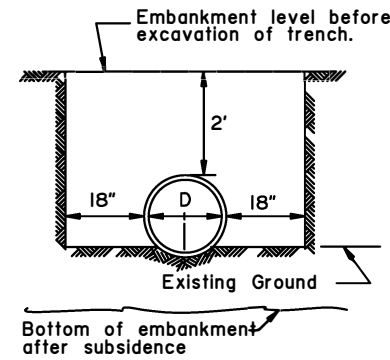

TYPE "B"

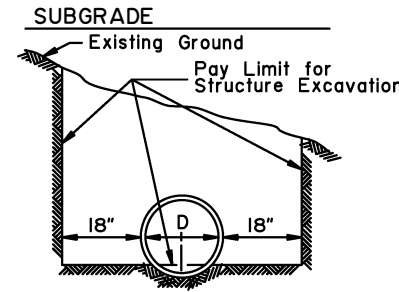

TYPE "C"

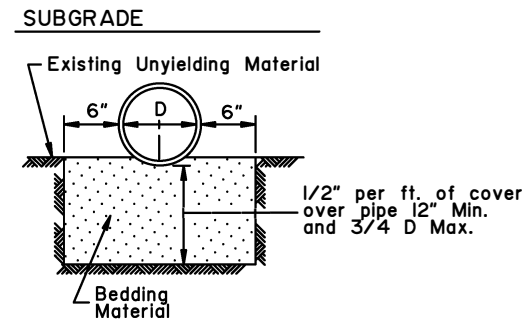

TYPE "D"
ROCK OR UNYIELDING MATERIAL

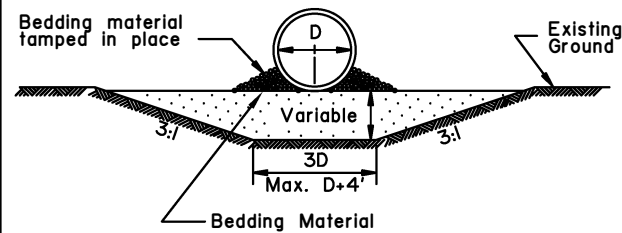

'ALTERNATE' TYPE "A"
FOUNDATION STABILIZATION
To be used in unstable areas as directed by the Engineer.

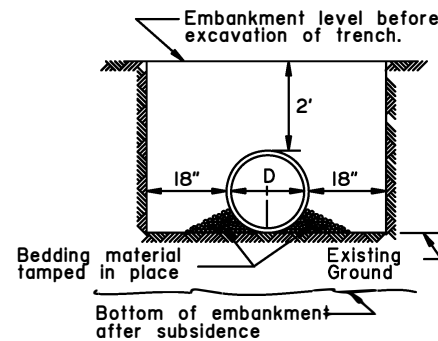

'ALTERNATE' TYPE "B"

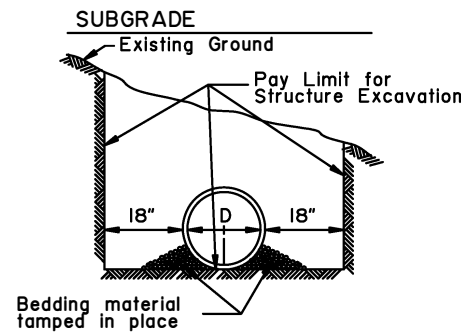

'ALTERNATE' TYPE "C"

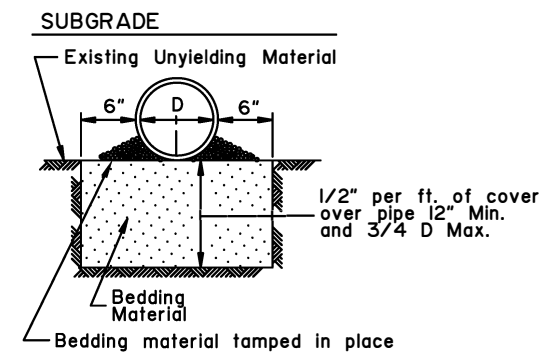

'ALTERNATE' TYPE "D"
ROCK OR UNYIELDING MATERIAL

D = Nominal Pipe Diameter

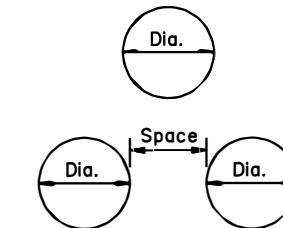

MULTIPLE INSTALLATIONS	
Dia.	Minimum Space Between Pipes
0" - 42"	24"
48" & Over	1/2 Dia. of pipe or 3', whichever is less.

S = Nominal Pipe Arch Span

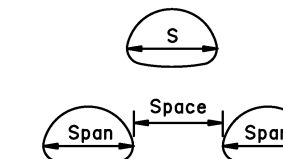

MULTIPLE INSTALLATIONS	
Dia.	Minimum Space Between Pipes
0" - 42"	24"
48" & Over	1/2 Span of pipe arch or 3', whichever is less.

CULVERT PIPE

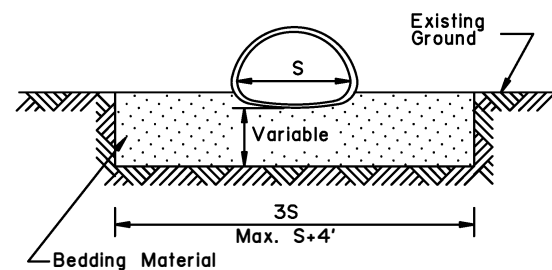

TYPE "A"
FOUNDATION STABILIZATION
To be used in unstable areas as directed by the Engineer.

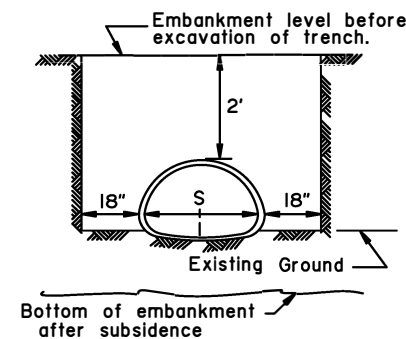

TYPE "B"

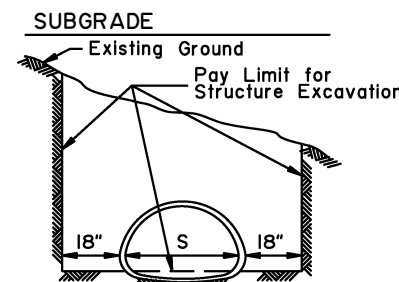

TYPE "C"

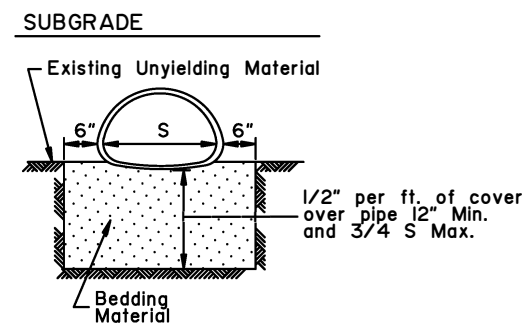

TYPE "D"
ROCK OR UNYIELDING MATERIAL

ARCH

State of Alaska DOT&PF
ALASKA STANDARD PLAN
CULVERT PIPE & ARCH
INSTALLATION DETAILS

Adopted as an Alaska Standard Plan by: *Kenneth J. Fisher*
Kenneth J. Fisher, P.E.
Chief Engineer

Adoption Date: 02/08/2019

Last Code and Stds. Review
By: Date:

Next Code and Standards Review date: 02/08/2029

GENERAL NOTES:

- All material and workmanship shall be in accordance with the State of Alaska, Standard Specifications for Highway Construction.
- The contractor shall select only pipes that meet specific height of cover criteria shown on the plans or in the special provisions.
- No more than one type of pipe may be used on any single installation or installation grouping.
- All structural plate pipes shall be placed on a pre-shaped foundation conforming to the depth of the bottom plates with clearance for assembling to the adjacent plates allowed.
- See Standard Plan D-01 "Culvert Pipe & Arch Installation Details" for foundation and structural backfill details.
- Minimum cover shall be measured from the top of pipe to the top of rigid pavement or to the bottom of flexible pavement subgrade. In all cases, the minimum cover shall not be less than 12". Minimum cover during construction shall be that required to protect the pipe from damage or deflection.
- These tables have been developed for an HL-93 live load and for compacted soil weighing 120 lbs. per cubic foot or less. If compacted soil cover exceeds 120 lbs. per cubic foot, the contractor shall use the depth of cover shown in the plans for the specific pipe. Where compacted soil cover exceeds 120 lbs. per cubic foot and no specific cover requirements are provided in the plans, the contractor shall determine the required minimum pipe cover in accordance with Section 12 of the 2017 AASHTO "LRFD Bridge Design Specifications".

Gage		16	14	12	10	8
Thickness		0.060	0.075	0.105	0.135	0.164
Dia. (In)	Min. (In)	Max. (Ft)	Max. (Ft)	Max. (Ft)	Max. (Ft)	Max. (Ft)
12	12	100+	100+	100+	100+	100+
15	12	100	100+	100+	100+	100+
18	12	83	100+	100+	100+	100+
21	12	71	89	100+	100+	100+
24	12	62	78	100+	100+	100+
27	12		69	97	100+	100+
30	12		62	87	100+	100+
36	12		51	73	94	100+
42	12			62	80	100+
48	12			54	70	85
54	15			48	62	76
60	15				52	64
66	18					52
72	18					43

Gage		16	14	12	10	8
Thickness		0.060	0.075	0.105	0.135	0.164
Dia. (In)	Min. (In)	Max. (Ft)	Max. (Ft)	Max. (Ft)	Max. (Ft)	Max. (Ft)
30	12	57	72	100+	100+	100+
36	12	47	60	84	100+	100+
42	12	40	51	72	96	100+
48	12	35	44	62	84	99
54	15	31	39	55	74	88
60	15	28	35	50	67	79
66	18	25	32	45	61	72
72	18	23	29	41	56	66
78	21		27	38	51	61
84	21			35	48	56
90	24			33	44	52
96	24			31	41	49
102	24				39	46
108	24				37	43
114	24					39
120	24					36

Thickness	0.125		0.150
Dia. (In)	Min. (In)	Max. (Ft)	Max. (Ft)
84	18	31	
90	18	27	
96	18	27	
102	18	24	
108	18	24	
114	18	21	
120	24	21	
126	24	19	
132	30	19	
138	30	18	
144	30	18	
150	30		22
156	30		22
162	36		20
168	36		20

*5.33 - 3/4" dia. steel bolts per foot.

————— CORRUGATED CIRCULAR ALUMINUM PIPE —————

————— CORRUGATED ALUMINUM PIPE-ARCH —————

Span (Ft.-In.)	Rise (Ft.-In.)	Corner Radius (In)	Min. Thickness (In)	2 Tons/Sf Corner Bearing Pressure	
				Min. Cover (In)	Max. Cover (Ft)
17	13	3 4/8	16 (0.060)	12	13
21	15	4 1/8	16 (0.060)	12	12
24	18	4 7/8	16 (0.060)	12	12
28	20	5 4/8	14 (0.075)	12	12
35	24	6 7/8	14 (0.075)	12	12
42	29	8 2/8	12 (0.105)	12	12
49	33	9 5/8	12 (0.105)	15	12
57	38	11	10 (0.135)	15	12
64	43	12 3/8	10 (0.135)	18	12
71	47	13 6/8	8 (0.164)	18	12

Span (Ft.-In.)	Rise (Ft.-In.)	Corner Radius (In)	Min. Thickness (In)	2 Tons/Sf Corner Bearing Pressure	
				Min. Cover (In)	Max. Cover (Ft)
60	46	18 6/8	14 (0.075)	15	20
66	51	20 6/8	14 (0.075)	18	20
73	55	22 7/8	14 (0.075)	21	20
81	59	20 7/8	12 (0.105)	21	16
87	63	22 7/8	12 (0.105)	24	16
95	67	24 3/8	12 (0.105)	24	16
103	71	26 1/8	10 (0.135)	24	16
112	75	27 6/8	8 (0.164)	24	16

Span (Ft.-In.)	Rise (Ft.-In.)	Corner Radius (In)	Min. Thickness (In)	Min. Cover (In)	2 Tons/Sf Corner Bearing Pressure
					Max. Cover (Ft)
6-7	5-8	31.75	0.125	24	24
6-11	5-9	31.75	0.125	24	24
7-3	5-11	31.75	0.125	24	18
7-9	6-0	31.75	0.125	24	18
8-5	6-3	31.75	0.125	24	16
9-3	6-5	31.75	0.125	24	15
10-3	6-9	31.75	0.125	30	13
10-9	6-10	31.75	0.125	30	13
11-5	7-1	31.75	0.125	30	13
12-7	7-5	31.75	0.125	30	11
12-11	7-6	31.75	0.125	30	11
13-1	8-2	31.75	0.125	30	11
13-11	8-5	31.75	0.125	36	10
14-8	9-8	31.75	0.125	36	9
15-4	10-0	31.75	0.150	36	8
16-1	10-4	31.75	0.150	36	8
16-9	10-8	31.75	0.150	42	7
17-3	11-0	31.75	0.150	42	7
18-0	11-4	31.75	0.175	42	7
18-8	11-8	31.75	0.175	42	7

*5.33 - 3/4" dia. steel bolts per foot.

State of Alaska DOT&PF
ALASKA STANDARD PLAN
PIPE AND ARCH TABLES

Adopted as an Alaska Standard Plan by: *Carolyn Morehouse*
Carolyn Morehouse, P.E.
Chief Engineer

Adoption Date: 7/17/2020

Last Code and Stds. Review
By: KLH Date: 7/8/2020

Next Code and Standards Review date: 7/8/2030

Minimum & Maximum Cover for 2 2/3" x 1/2" Steel Pipe

Gage		16	14	12	10	8
Thickness		0.060	0.075	0.105	0.135	0.164
Dia. (In)	Min. (In)	Max. (Ft)	Max. (Ft)	Max. (Ft)	Max. (Ft)	Max. (Ft)
12	12	100+	100+	100+	100+	100+
15	12	100+	100+	100+	100+	100+
18	12	100+	100+	100+	100+	100+
21	12	100+	100+	100+	100+	100+
24	12	100+	100+	100+	100+	100+
30	12	83	100+	100+	100+	100+
36	12	69	86	100+	100+	100+
42	12	59	74	100+	100+	100+
48	12	51	64	91	100+	100+
54	12		57	80	100+	100+
60	12			72	93	100+
66	12			66	85	100+
72	12				78	95
78	12					84
84	12					73

Minimum & Maximum Cover for 3" x 1" Steel Pipe

Gage		16	14	12	10	8
Thickness		0.060	0.075	0.105	0.135	0.164
Dia. (In)	Min. (In)	Max. (Ft)	Max. (Ft)	Max. (Ft)	Max. (Ft)	Max. (Ft)
36	12			100+	100+	100+
42	12			100+	100+	100+
48	12		74	100+	100+	100+
54	12	53	66	93	100+	100+
60	12	47	59	83	100+	100+
66	12	43	54	76	98	100+
72	12	39	49	69	89	100+
78	12	36	45	64	82	100+
84	12	33	42	59	77	94
90	12	31	39	55	71	87
96	12	29	37	52	67	82
102	18	27	34	49	63	77
108	18		32	46	59	73
114	18		31	43	56	69
120	18		29	41	53	65
126	18			39	51	62
132	18			37	48	59
138	18			36	46	57
144	18			44	54	

Minimum & Maximum Cover for 5" x 1" Steel Pipe

Gage		16	14	12	10	8
Thickness		0.060	0.075	0.105	0.135	0.164
Dia. (In)	Min. (In)	Max. (Ft)	Max. (Ft)	Max. (Ft)	Max. (Ft)	Max. (Ft)
36	12	71	88	100+	100+	100+
42	12	60	76	100+	100+	100+
48	12	53	66	93	100+	100+
54	12	47	59	82	100+	100+
60	12	42	53	74	96	100+
66	12	38	48	67	87	100+
72	12	35	44	62	79	97
78	12	32	40	57	73	90
84	12	30	37	53	68	83
90	12	28	35	49	63	78
96	12	26	33	46	59	73
102	18	24	31	43	56	69
108	18		29	41	53	65
114	18		27	39	50	61
120	18		26	37	47	58
126	18			35	45	55
132	18			33	43	53
138	18			32	41	50
144	18			39	48	

Minimum & Maximum Cover for 6" x 2" Steel Multiplate Pipe*

Gage		12	10	8	7	5	3	1
Thickness		0.111	0.140	0.170	0.188	0.218	0.249	0.280
Dia. (In)	Min. (In)	Max. (Ft)	Max. (Ft)	Max. (Ft)	Max. (Ft)	Max. (Ft)	Max. (Ft)	Max. (Ft)
60	12	46	67	87	100	100+	100+	100+
66	12	42	60	79	91	100+	100+	100+
72	12	38	55	73	83	100+	100+	100+
78	12	35	51	67	77	93	100+	100+
84	12	32	47	62	71	86	100+	100+
90	12	30	44	58	67	80	95	100+
96	12	28	41	54	62	75	89	97
102	18	27	39	51	59	71	84	91
108	18	25	37	48	55	67	79	86
114	18	24	35	45	52	63	75	82
120	18	22	33	43	50	60	71	77
126	18	21	31	41	47	57	68	74
132	18	20	30	39	45	54	64	70
138	18	19	28	37	43	52	62	67
144	18	18	27	36	41	50	59	64

*4 - 3/4" dia. steel bolts per foot.

GENERAL NOTES

- All material and workmanship shall be in accordance with the State of Alaska, Standard Specifications for Highway Construction.
- The contractor shall select only pipes that meet specific height of cover criteria shown on the plans or in the special provisions.
- No more than one type of pipe may be used on any single installation or installation grouping.
- All structural plate pipes shall be placed on a pre-shaped foundation conforming to the depth of the bottom plates with clearance for assembling to the adjacent plates allowed.
- See Standard Plan D-01 "Culvert Pipe & Arch Installation Details" for foundation and structural backfill details.
- Minimum cover shall be measured from the top of pipe to the top of rigid pavement or to the bottom of flexible pavement subgrade. In all cases, the minimum cover shall not be less than 12". Minimum cover during construction shall be that required to protect the pipe from damage or deflection.
- These tables have been developed for an HL-93 live load and for compacted soil weighing 120 lbs. per cubic foot or less. If compacted soil cover exceeds 120 lbs. per cubic foot, the contractor shall use the depth of cover shown in the plans for the specific pipe. Where compacted soil cover exceeds 120 lbs. per cubic foot and no specific cover requirements are provided in the plans, the contractor shall determine the required minimum pipe cover in accordance with Section 12 of the 2017 AASHTO "LRFD Bridge Design Specifications".

CORRUGATED CIRCULAR STEEL PIPE

CORRUGATED STEEL PIPE-ARCH

Minimum & Maximum Cover for 2 2/3" X 1/2" Steel Pipe-Arch

2 Tons/Sf Corner Bearing Pressure						
Span (Ft.-In.)	Rise (Ft.-In.)	Corner Radius (In)	Min. Thickness (In)	Min. Cover (In)	Max. Cover (Ft)	
17	13	3 4/8	16 [0.060]	12	11	
21	15	4 1/8	16 [0.060]	12	11	
24	18	4 7/8	16 [0.060]	12	11	
28	20	5 4/8	16 [0.060]	12	11	
35	24	6 7/8	16 [0.060]	12	11	
42	29	8 2/8	16 [0.060]	12	11	
49	33	9 5/8	14 [0.075]	12	11	
57	38	11	12 [0.109]	12	11	
64	43	12 3/8	12 [0.109]	12	11	
71	47	13 6/8	10 [0.138]	12	11	
77	52	15 1/8	10 [0.138]	12	11	
83	57	16 4/8	8 [0.168]	12	11	

Minimum & Maximum Cover for 3" X 1" Steel Pipe-Arch

2 Tons/Sf Corner Bearing Pressure						
Span (Ft.-In.)	Rise (Ft.-In.)	Corner Radius (In)	Min. Thickness (In)	Min. Cover (In)	Max. Cover (Ft)	
53	41	10 2/8	14 [0.079]	12	10	
60	46	18 6/8	14 [0.079]	15	29	
66	51	20 6/8	14 [0.079]	15	29	
73	55	22 7/8	14 [0.079]	18	18	
81	59	20 7/8	14 [0.079]	18	15	
87	63	22 7/8	14 [0.079]	18	15	
95	67	24 3/8	14 [0.079]	18	15	
103	71	26 1/8	14 [0.079]	18	14	
112	75	27 6/8	14 [0.079]	21	14	
117	79	29 4/8	12 [0.109]	21	14	
128	83	31 2/8	10 [0.138]	24	14	
137	87	33	10 [0.138]	24	14	
142	91	34 6/8	10 [0.138]	24	13	
150	96	36	10 [0.138]	30	13	
157	96	38	10 [0.138]	30	13	
164	105	40	10 [0.138]	30	14	
171	110	41	10 [0.138]	30	13	

Minimum & Maximum Cover for 5" X 1" Steel Pipe-Arch

2 Tons/Sf Corner Bearing Pressure						
Span (Ft.-In.)	Rise (Ft.-In.)	Corner Radius (In)	Min. Thickness (In)	Min. Cover (In)	Max. Cover (Ft)	
53	41	10 2/8	14 [0.079]	12	10	
60	46	18 6/8	14 [0.079]	15	29	
66	51	20 6/8	14 [0.079]	15	29	
73	55	22 7/8	14 [0.079]	18	18	
81	59	20 7/8	14 [0.079]	18	15	
87	63	22 7/8	14 [0.079]	18	15	
95	67	24 3/8	14 [0.079]	18	15	
103	71	26 1/8	14 [0.079]	18	14	
112	75	27 6/8	14 [0.079]	21	14	
117	79	29 4/8	12 [0.109]	21	14	
128	83	31 2/8	10 [0.138]	24	14	
137	87	33	10 [0.138]	24	14	
142	91	34 6/8	10 [0.138]	24	13	
150	96	36	10 [0.138]	30	13	
157	96	38	10 [0.138]	30	13	
164	105	40	10 [0.138]	30	14	
171	110	41	10 [0.138]	30	13	

Minimum & Maximum Cover for Steel Multiplate Pipe-Arch 6" x 2" *

2 Tons/Sf Corner Bearing Pressure						
Span (Ft.-In.)	Rise (Ft.-In.)	Corner Radius (In)	Min. Gage (In)	Min. Cover (In)	Max. Cover (Ft)	
6-1	4-7	18	12 [0.111]	12	14	
7-0	5-1	18	12 [0.111]	12	12	
7-11	5-7	18	12 [0.111]	12	10	
8-10	6-1	18	12 [0.111]	18	9	
9-9	6-7	18	12 [0.111]	18	8	
10-11	7-1	18	12 [0.111]	18	6	
11-10	7-7	18	12 [0.111]	18	5	
12-10	8-4	18	12 [0.111]	24	5	
13-3	9-4	31	10 [0.140]	24	11	
14-2	9-10	31	10 [0.140]	24	10	
15-4	10-4	31	10 [0.140]	24	9	
16-3	10-10	31	10 [0.140]	30	8	
17-2	11-4	31	10 [0.140]	30	8	
18-1	11-10	31	10 [0.140]	30	7	
19-3	12-4	31	10 [0.140]	30	7	
19-11	12-10	31	10 [0.140]	30	6	
20-7	13-2	31	10 [0.140]	36	6	

*4 - 3/4" dia. steel bolts per foot.

State of Alaska DOT&PF
ALASKA STANDARD PLAN

PIPE AND ARCH TABLES

Adopted as an Alaska Standard Plan by: *Carolyn Morehouse*
Carolyn Morehouse, P.E.
Chief Engineer

Adoption Date: 7/17/2020

Last Code and Stds. Review
By: KLH Date: 7/8/2020

Next Code and Standards Review date: 7/8/2030

GENERAL NOTES

1. All materials and workmanship shall be in accordance with the State of Alaska Standard Specifications for Highway Construction.
2. For foundation and structural backfill details see Standard Plan D-01 "Culvert Pipe & Arch Installation Details".
3. Pipe cover height is measured from top of the pipe to top of rigid pavement, or to the bottom of subgrade for flexible pavement. In all cases the minimum cover shall be no less than 2 ft. Where loads traverse the culvert during construction minimum cover shall be no less than 4 ft.

Maximum Cover for Type S Corrugated Polyethylene Pipe	
Size (in)	Max. Cover (ft)
12	24
15	25
18	24
24	20
30	20
36	18
42	16
48	17

State of Alaska DOT&PF
ALASKA STANDARD PLAN

PIPE AND ARCH TABLES

Adopted as an Alaska Standard Plan by: *Carolyn Morehouse*
Carolyn Morehouse, P.E.
Chief Engineer

Adoption Date: 7/17/2020

Last Code and Stds. Review
By: KLH Date: 7/8/2020

Next Code and Standards Review date: 7/8/2030

GENERAL NOTES

- All material and workmanship shall be in accordance with the State of Alaska, Standard Specifications for Highway Construction.
- The contractor shall select only pipes that meet specific height of cover criteria shown on the plans or in the special provisions.
- No more than one type of pipe may be used on any single installation or installation grouping.
- All structural plate pipes shall be placed on a pre-shaped foundation conforming to the depth of the bottom plates with clearance for assembling to the adjacent plates allowed.
- See Standard Plan D-01 "Culvert Pipe & Arch Installation Details" for foundation and structural backfill details.
- Minimum cover shall be measured from the top of pipe to the top of rigid pavement or to the bottom of flexible pavement subgrade. In all cases, the minimum cover shall not be less than 12". Minimum cover during construction shall be that required to protect the pipe from damage or deflection.
- These tables have been developed for an HL-93 live load and for compacted soil weighing 120 lbs. per cubic foot or less. If compacted soil cover exceeds 120 lbs. per cubic foot, the contractor shall use the depth of cover shown in the plans for the specific pipe. Where compacted soil cover exceeds 120 lbs. per cubic foot and no specific cover requirements are provided in the plans, the contractor shall determine the required minimum pipe cover in accordance with Section 12 of the 2017 AASHTO "LRFD Bridge Design Specifications".

Minimum & Maximum Cover for Aluminum Spiral Rib Circular Pipe*					
Gage		16	14	12	10
Thickness		0.064	0.079	0.109	0.138
Dia. (In)	Min. (In)	Max. (Ft)	Max. (Ft)	Max. (Ft)	Max. (Ft)
18	12	43	61		
21	12	38	52	84	
24	12	33	45	73	
30	15	26	36	58	
36	18	21	30	49	69
42	21		25	41	59
48	24			36	51
54	24			32	46
60	24			29	41
66	24				37
72	30				34

* $\frac{3}{4}$ x $\frac{3}{4}$ x $7\frac{1}{2}$ in. Corrugations

Minimum & Maximum Cover for Aluminum Spiral Rib Pipe-Arch*					
Gage		16	14	12	10
Thickness		0.060	0.075	0.105	0.135
Span (Ft.-In.)	Rise (Ft.-In.)	Min. Cover (In)	Max. Cover (Ft)		
20	16	12	16		
23	19	12	15		
27	21	15	13	13	
33	26	18	13	13	13
40	31	21		13	13
46	36	24			13
53	41	24			13
60	46	24			13
66	51	24			13

* $\frac{3}{4}$ x $\frac{3}{4}$ x $7\frac{1}{2}$ in. Corrugations

ALUMINUM SPIRAL RIB PIPE

STEEL SPIRAL RIB PIPE

Minimum & Maximum Cover for Steel and Aluminized Steel Spiral Rib Circular Pipe*					
Gage		16	14	12	10
Thickness		0.064	0.079	0.109	0.138
Dia. (In)	Min. (In)	Max. (Ft)	Max. (Ft)	Max. (Ft)	Max. (Ft)
18	12	91			
24	12	68	95	100+	
30	12	54	76	100+	
36	12	45	63	100+	
42	12	38	54	90	
48	12	33	47	79	
54	18	30	42	70	
60	18	27	38	63	92
66	18	24	34	57	83
72	18		31	52	76
78	24		29	48	70
84	24		27	45	65
90	24			42	61
96	24			39	56
102	30			36	50
108	30			32	45

* $\frac{3}{4}$ x $\frac{3}{4}$ x $7\frac{1}{2}$ in. Corrugations.

Minimum & Maximum Cover for Steel Spiral Rib Pipe-Arch*					
2 Tons/Sf Corner Bearing Pressure					
Gage		16	14	12	10
Thickness		0.064	0.079	0.109	
Span (Ft.-In.)	Rise (Ft.-In.)	Min. Cover (In)	Max. Cover (Ft)		
20	16	12	13		
23	19	12	13		
27	21	12	11		
33	26	12	11		
40	31	12	11		
46	36	12	11		
53	41	18		11	
60	46	18		19	
66	51	18		19	
73	55	18			18
81	59	18			15
87	63	18			15
95	67	18			15

* $\frac{3}{4}$ x $\frac{3}{4}$ x $7\frac{1}{2}$ in. Corrugations

State of Alaska DOT&PF
ALASKA STANDARD PLAN

PIPE AND ARCH TABLES

Adopted as an Alaska Standard Plan by: *Carolyn Morehouse*

Carolyn Morehouse, P.E.
Chief Engineer

Adoption Date: 7/17/2020

Last Code and Stds. Review
By: KLH Date: 7/8/2020

Next Code and Standards Review date: 7/8/2030

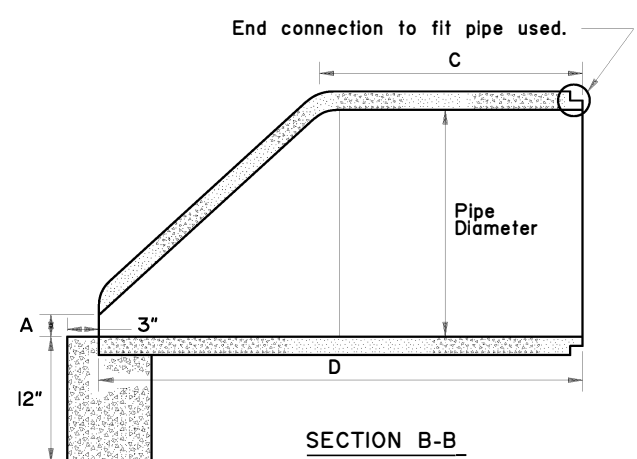
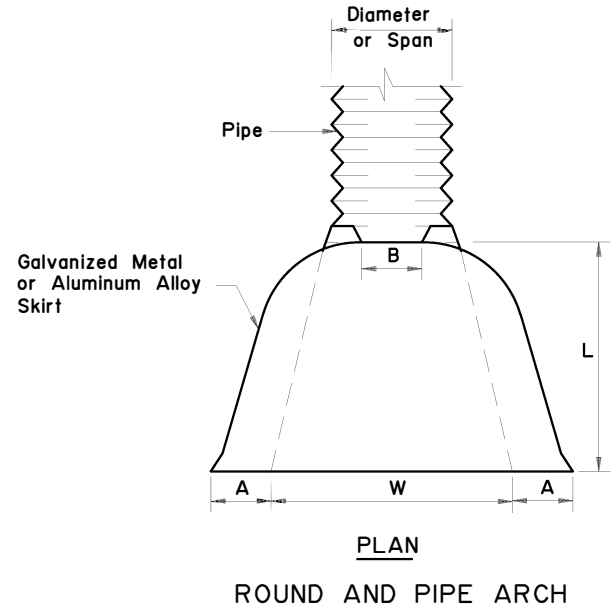

MINIMUM DIMENSIONS					
Pipe Diameter	A	B	C	D	E
12"	4"	1 3/4"	24"	46"	24"
18"	9"	2"	25"	50"	36"
24"	9 1/2"	2 1/2"	30"	72"	48"
30"	12"	3"	20"	73"	60"
36"	15"	3 3/8"	35"	97"	72"
42"	21"	3 3/4"	35"	98"	78"
48"	24"	4 1/4"	26"	98"	84"
54"	27"	4 5/8"	33"	99"	82"

ROUND PIPE										
Pipe Diam. Inches	Thickness For Aluminum	Thk. for Galv. Metal	Dimension Inches					Skirt	Approx. Slope	
			1" A Tol.	B Max.	1" H Tol.	1 1/2" L Tol.	2" W Tol.			2" T Tol.
12"	0.060	0.064	6"	6"	6"	21"	24"	34"	1 Pc.	2 1/2
15"	0.060	0.064	7"	8"	6"	26"	30"	40"	1 Pc.	2 1/2
18"	0.060	0.064	8"	10"	6"	31"	36"	46"	1 Pc.	2 1/2
21"	0.060	0.064	9"	12"	6"	36"	42"	52"	1 Pc.	2 1/2
24"	0.075	0.064	10"	13"	6"	41"	48"	58"	1 Pc.	2 1/2
30"	0.075	0.079	12"	16"	8"	51"	60"	70"	1 Pc.	2 1/2
36"	0.105	0.079	14"	19"	9"	60"	72"	94"	2 Pc.	2 1/2
42"	0.105	0.109	16"	22"	11"	69"	84"	106"	2 Pc.	2 1/2
48"	0.105	0.109	18"	27"	12"	78"	90"	112"	2 Pc.	2 1/4
54"	0.105	0.109	18"	30"	12"	84"	102"	122"	2 Pc.	2 1/4
60"	0.135	0.109	18"	33"	12"	87"	114"	134"	3 Pc.	2 1/4
66"	0.135	0.109	18"	36"	12"	87"	120"	142"	3 Pc.	2 1/4
72"	0.135	0.109	18"	39"	12"	87"	126"	146"	3 Pc.	2 1/4
78"	---	0.109	18"	42"	12"	87"	132"	152"	3 Pc.	1 1/4
84"	---	0.109	18"	45"	12"	87"	138"	158"	3 Pc.	1 1/6

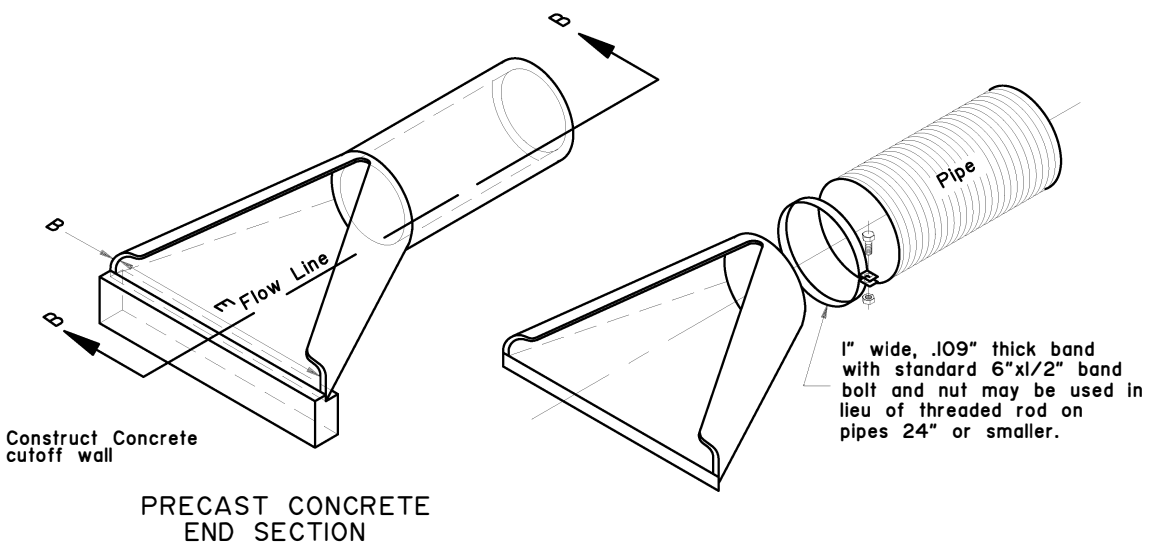
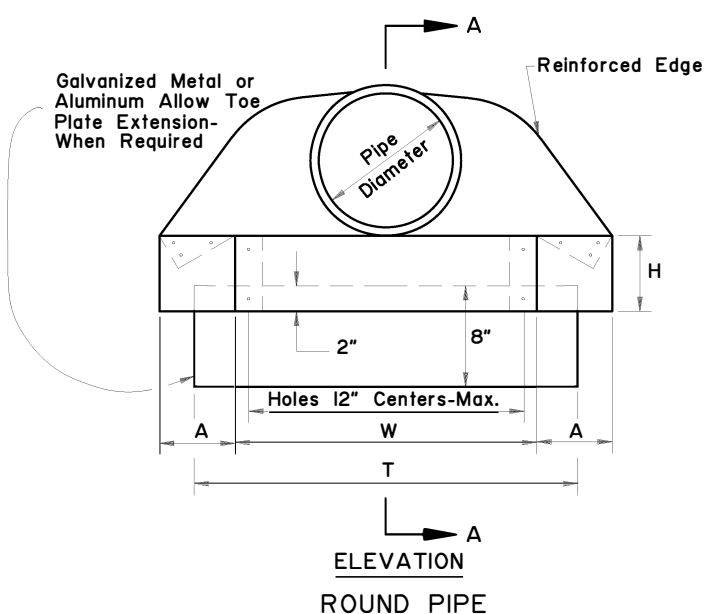

PIPE-ARCH												
Pipe-Arch Dimension Inches	Span	Rise	Thickness for Aluminum	Thk. for Galv. Metal	Dimension Inches					Skirt	Approx. Slope	
					1" A Tol.	B Max.	1" H Tol.	1 1/2" L Tol.	2" W Tol.			2" T Tol.
17"	13"		0.060	0.064	7"	9"	6"	19"	30"	40"	1 Pc.	2 1/2
21"	15"		0.060	0.064	7"	10"	6"	23"	36"	46"	1 Pc.	2 1/2
24"	18"		0.060	0.064	8"	12"	6"	28"	42"	52"	1 Pc.	2 1/2
28"	20"		0.075	0.064	9"	14"	6"	32"	48"	58"	1 Pc.	2 1/2
35"	24"		0.075	0.079	10"	16"	6"	39"	60"	70"	1 Pc.	2 1/2
42"	29"		0.105	0.079	12"	18"	8"	46"	75"	85"	1 Pc.	2 1/2
49"	33"		0.105	0.109	13"	21"	9"	53"	85"	103"	2 Pc.	2 1/2
57"	38"		0.105	0.109	18"	26"	12"	63"	90"	114"	2 Pc.	2 1/2
64"	43"		0.105	0.109	18"	30"	12"	70"	102"	130"	2 Pc.	2 1/4
71"	47"		0.135	0.109	18"	33"	12"	77"	114"	144"	3 Pc.	2 1/4
77"	52"		0.135	0.109	18"	36"	12"	84"	120"	158"	3 Pc.	2 1/4
83"	57"		0.135	0.109	18"	39"	12"	90"	126"	170"	3 Pc.	2 1/4

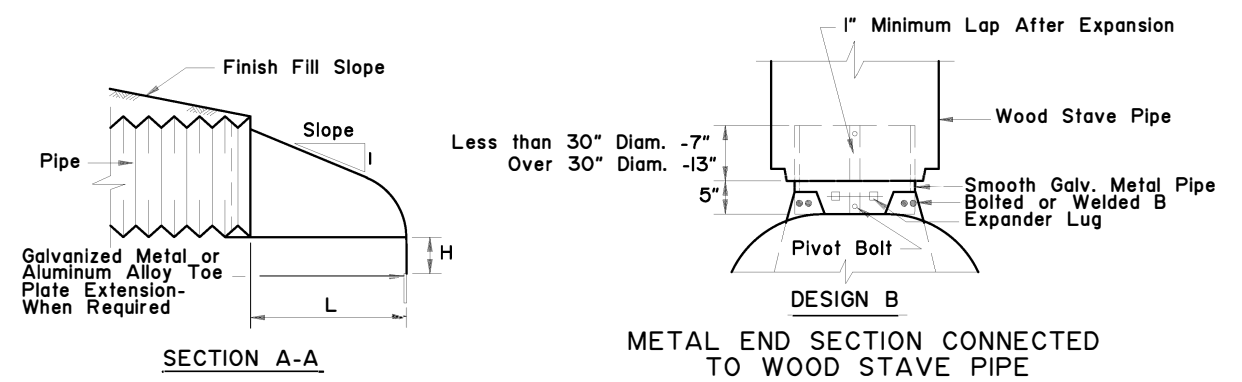
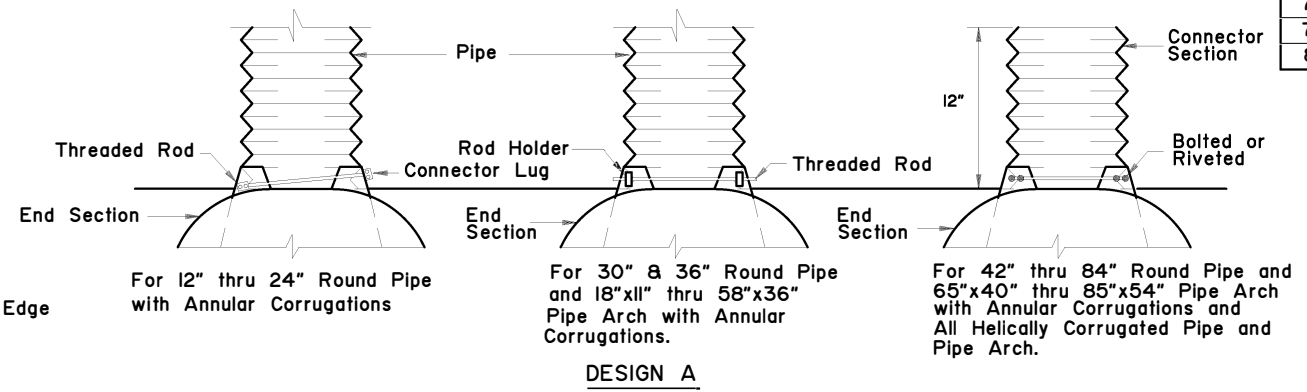
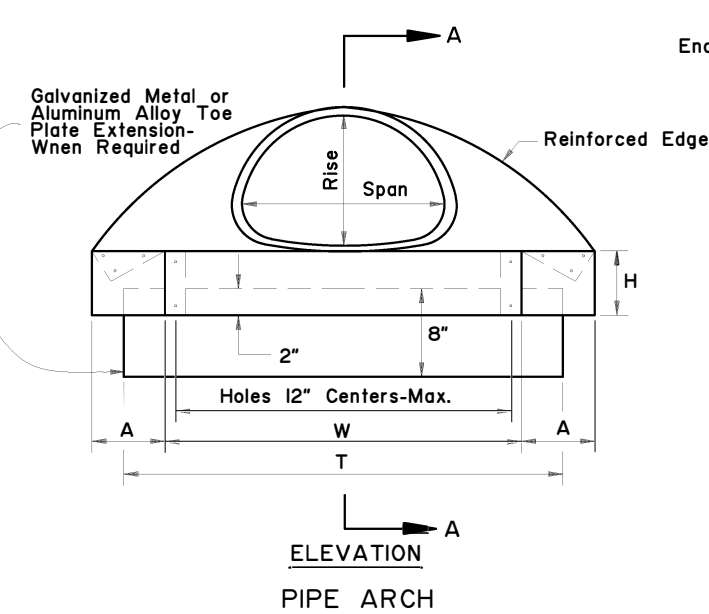

GENERAL NOTES:

1. Toe plate extensions will be required only when provided for on the plans. When required, the toe plate extensions shall be punched with holes to match those in lip of skirt and fastened with 3/8 inch or larger galvanized nuts and bolts and shall be the same gage as the end section.
2. Galvanized Metal or Aluminum Alloy End Sections may be used on Wood Stave and Plastic Pipe.
3. All 3 piece bodies shall have 12 gage sides and 10 gage center panels. Multiple panel bodies shall have lap seams which are to be tightly joined by 3/8" galvanized rivets or bolts.

State of Alaska DOT&PF
ALASKA STANDARD PLAN

CULVERT END SECTIONS

Adopted as an Alaska Standard Plan by: *Kenneth J. Fisher*
Kenneth J. Fisher, P.E.
Chief Engineer

Adoption Date: 02/08/2019

Last Code and Stds. Review By: _____ Date: _____

Next Code and Standards Review date: 02/08/2029

GENERAL NOTES

1. See general notes on sheet 1 of 3.
2. See sheet 1 of 3 for metal end section dimensions.
3. Insert bolts, washers and rivets shall be galvanized. Insert thickness is the same as the end section.
4. Use culvert inserts only at inlet.

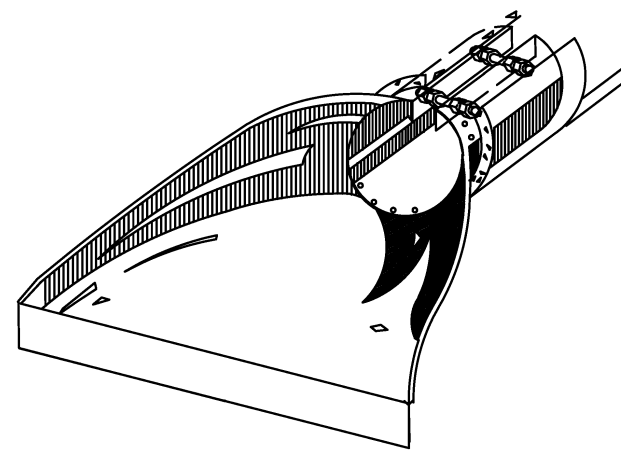

FOR CONNECTING CONCRETE PIPE OR CORRUGATED POLYETHYLENE PIPE TO METAL END SECTION.

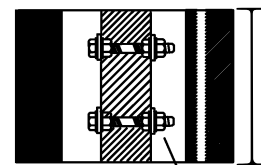

SEE NOTE 2

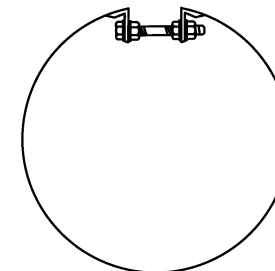

5/8" GALV. BOLTS

METAL INSERTS FOR USE WITH CORRUGATED PLASTIC
PIPE AND
METAL END SECTIONS

State of Alaska DOT&PF
ALASKA STANDARD PLAN

CULVERT END SECTIONS

Adopted as an Alaska
 Standard Plan by: *Kenneth J. Fisher*
 Kenneth J. Fisher, P.E.
 Chief Engineer

Adoption Date: 02/08/2019

Last Code and Stds. Review
By: Date:

Next Code and Standards Review date: 02/08/2029

GENERAL NOTES

1. Plastic flared end sections may be used with HDPE corrugated culvert pipes where noted in project plans or approved by project engineer.
2. Consult manufacturer's recommendations for proper sizing and coupling devices. Recommended fasteners may include connecting bands or cinch ties. Fittings across dimension B may include threaded rods with wing nuts or bolts and washers, plastic welds may be recommended.
3. Align coupling to accommodate pipe corrugations.
4. Metal components e.g. bolts or washers must be galvanized.
5. Attachment of end section should preserve culvert alignment and not impair pipe function. Use end sections only on culvert inlet.
6. Toe plate extensions will be required only when designated on the plans.
7. End sections will not be used on HDPE culvert pipes larger than 36" unless indicated by project plans or approved by the Engineer.

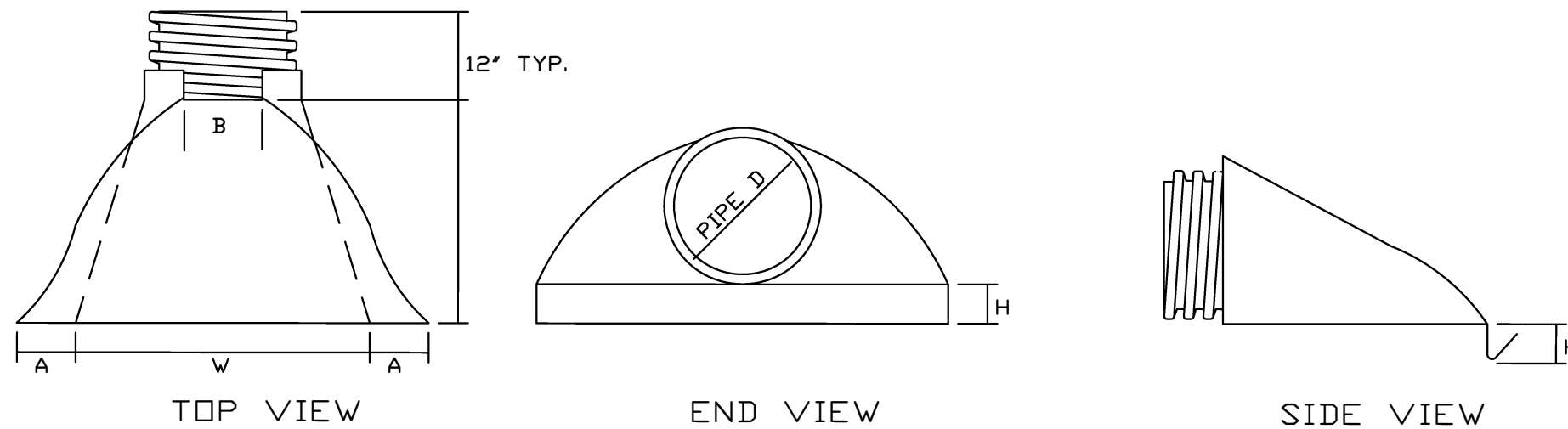

PIPE DIAMETER	DIMENSIONS IN MILLIMETERS				
	A(1"±)	B MAX	H(1"±)	L(1/2"±)	W(2"±)
12" and 15"	6 1/2"	10"	6 1/2"	25"	29"
18"	7 1/2"	15"	6 1/2"	32"	35"
24"	7 1/2"	18"	6 1/2"	36"	45"
30"	10 1/2"	N/A	7"	53"	68"
36"	10 1/2"	N/A	7"	53"	68"

PLASTIC END SECTION FOR CORRUGATED PLASTIC PIPE

State of Alaska DOT&PF
ALASKA STANDARD PLAN

CULVERT END SECTIONS

Adopted as an Alaska
Standard Plan by: *Kenneth J. Fisher*
Kenneth J. Fisher, P.E.
Chief Engineer

Adoption Date: 02/08/2019

Last Code and Stds. Review
By: Date:

Next Code and Standards Review date: 02/08/2029

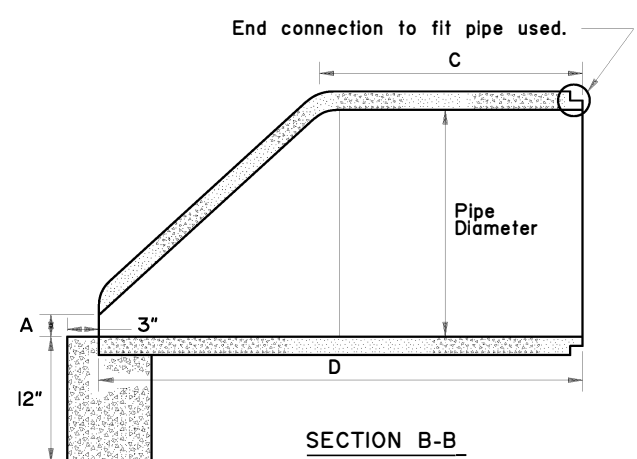
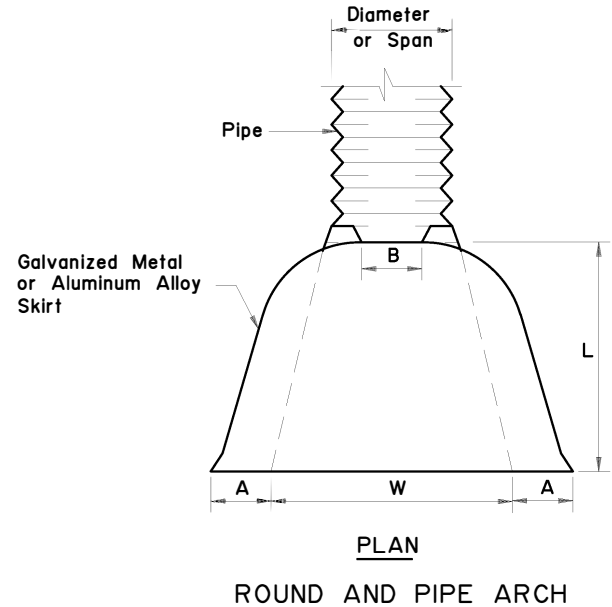

MINIMUM DIMENSIONS					
Pipe Diameter	A	B	C	D	E
12"	4"	1 3/4"	24"	46"	24"
18"	9"	2"	25"	50"	36"
24"	9 1/2"	2 1/2"	30"	72"	48"
30"	12"	3"	20"	73"	60"
36"	15"	3 3/8"	35"	97"	72"
42"	21"	3 3/4"	35"	98"	78"
48"	24"	4 1/4"	26"	98"	84"
54"	27"	4 5/8"	33"	99"	82"

ROUND PIPE										
Pipe Diam. Inches	Thickness For Aluminum	Thk. for Galv. Metal	Dimension Inches					Skirt	Approx. Slope	
			1" A Tol.	B Max.	1" H Tol.	1 1/2" L Tol.	2" W Tol.			2" T Tol.
12"	0.060	0.064	6"	6"	6"	21"	24"	34"	1 Pc.	2 1/2
15"	0.060	0.064	7"	8"	6"	26"	30"	40"	1 Pc.	2 1/2
18"	0.060	0.064	8"	10"	6"	31"	36"	46"	1 Pc.	2 1/2
21"	0.060	0.064	9"	12"	6"	36"	42"	52"	1 Pc.	2 1/2
24"	0.075	0.064	10"	13"	6"	41"	48"	58"	1 Pc.	2 1/2
30"	0.075	0.079	12"	16"	8"	51"	60"	70"	1 Pc.	2 1/2
36"	0.105	0.079	14"	19"	9"	60"	72"	94"	2 Pc.	2 1/2
42"	0.105	0.109	16"	22"	11"	69"	84"	106"	2 Pc.	2 1/2
48"	0.105	0.109	18"	27"	12"	78"	90"	112"	2 Pc.	2 1/4
54"	0.105	0.109	18"	30"	12"	84"	102"	122"	2 Pc.	2 1/4
60"	0.135	0.109	18"	33"	12"	87"	114"	134"	3 Pc.	2 1/4
66"	0.135	0.109	18"	36"	12"	87"	120"	142"	3 Pc.	2 1/4
72"	0.135	0.109	18"	39"	12"	87"	126"	146"	3 Pc.	2 1/4
78"	---	0.109	18"	42"	12"	87"	132"	152"	3 Pc.	1 1/4
84"	---	0.109	18"	45"	12"	87"	138"	158"	3 Pc.	1 1/6

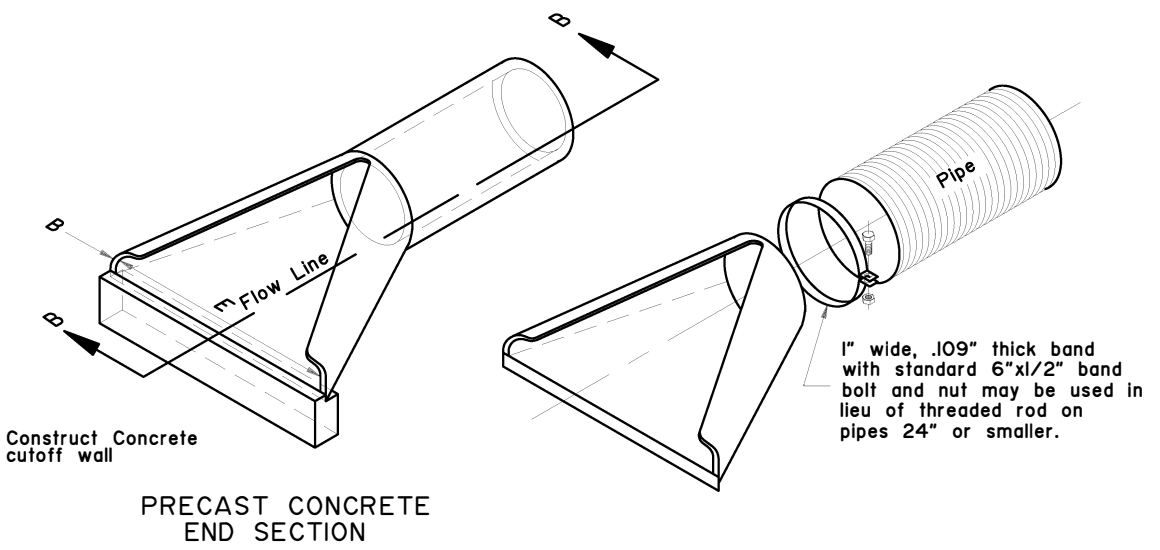
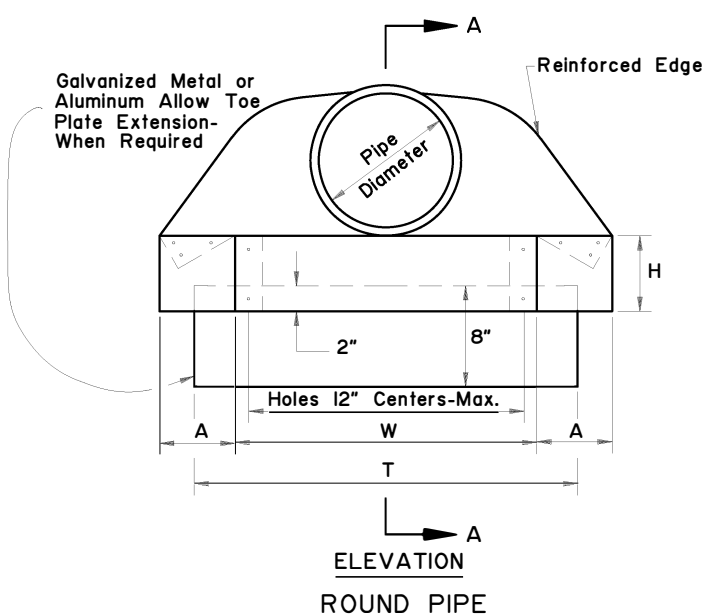

PIPE-ARCH												
Pipe-Arch Dimension Inches	Span	Rise	Thickness for Aluminum	Thk. for Galv. Metal	Dimension Inches					Skirt	Approx. Slope	
					1" A Tol.	B Max.	1" H Tol.	1 1/2" L Tol.	2" W Tol.			2" T Tol.
17"	13"		0.060	0.064	7"	9"	6"	19"	30"	40"	1 Pc.	2 1/2
21"	15"		0.060	0.064	7"	10"	6"	23"	36"	46"	1 Pc.	2 1/2
24"	18"		0.060	0.064	8"	12"	6"	28"	42"	52"	1 Pc.	2 1/2
28"	20"		0.075	0.064	9"	14"	6"	32"	48"	58"	1 Pc.	2 1/2
35"	24"		0.075	0.079	10"	16"	6"	39"	60"	70"	1 Pc.	2 1/2
42"	29"		0.105	0.079	12"	18"	8"	46"	75"	85"	1 Pc.	2 1/2
49"	33"		0.105	0.109	13"	21"	9"	53"	85"	103"	2 Pc.	2 1/2
57"	38"		0.105	0.109	18"	26"	12"	63"	90"	114"	2 Pc.	2 1/2
64"	43"		0.105	0.109	18"	30"	12"	70"	102"	130"	2 Pc.	2 1/4
71"	47"		0.135	0.109	18"	33"	12"	77"	114"	144"	3 Pc.	2 1/4
77"	52"		0.135	0.109	18"	36"	12"	84"	120"	158"	3 Pc.	2 1/4
83"	57"		0.135	0.109	18"	39"	12"	90"	126"	170"	3 Pc.	2 1/4

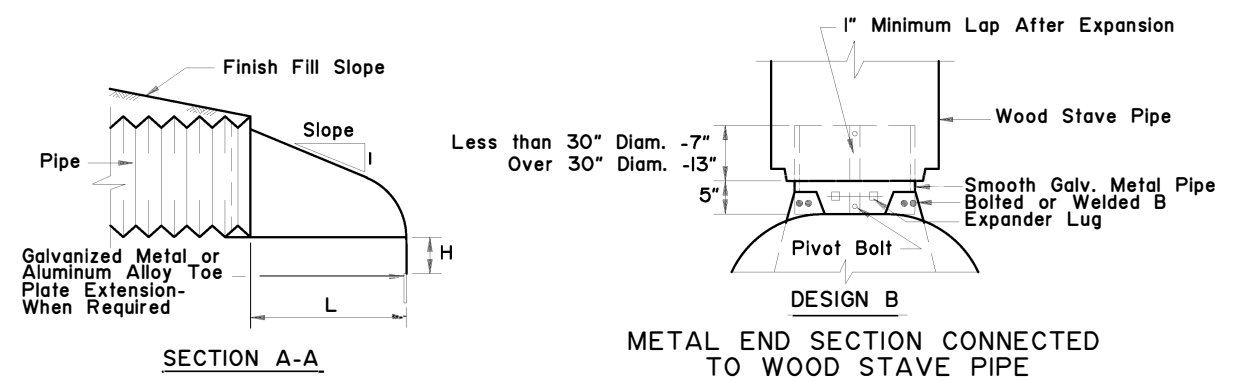
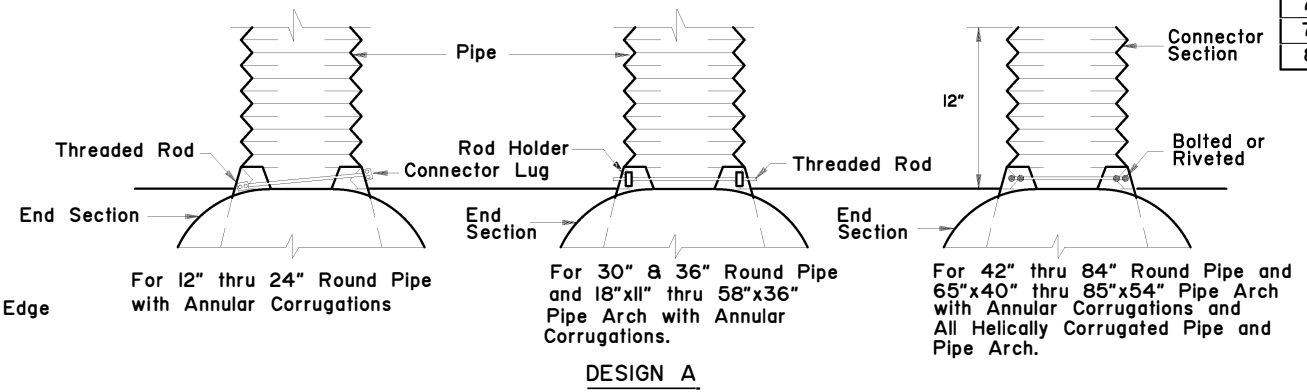
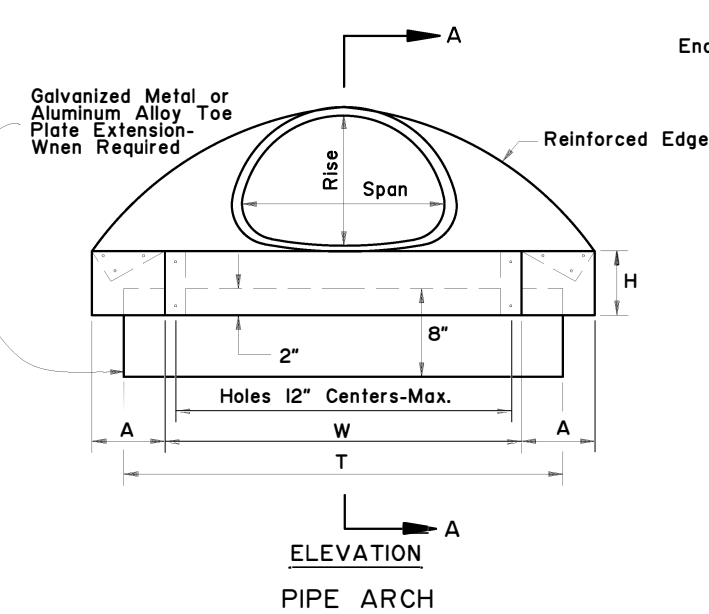

GENERAL NOTES:

1. Toe plate extensions will be required only when provided for on the plans. When required, the toe plate extensions shall be punched with holes to match those in lip of skirt and fastened with 3/8 inch or larger galvanized nuts and bolts and shall be the same gage as the end section.
2. Galvanized Metal or Aluminum Alloy End Sections may be used on Wood Stave and Plastic Pipe.
3. All 3 piece bodies shall have 12 gage sides and 10 gage center panels. Multiple panel bodies shall have lap seams which are to be tightly joined by 3/8" galvanized rivets or bolts.

State of Alaska DOT&PF
ALASKA STANDARD PLAN

CULVERT END SECTIONS

Adopted as an Alaska Standard Plan by: *Kenneth J. Fisher*
Kenneth J. Fisher, P.E.
Chief Engineer

Adoption Date: 02/08/2019

Last Code and Stds. Review By: _____ Date: _____

Next Code and Standards Review date: 02/08/2029

GENERAL NOTES

1. See general notes on sheet 1 of 3.
2. See sheet 1 of 3 for metal end section dimensions.
3. Insert bolts, washers and rivets shall be galvanized. Insert thickness is the same as the end section.
4. Use culvert inserts only at inlet.

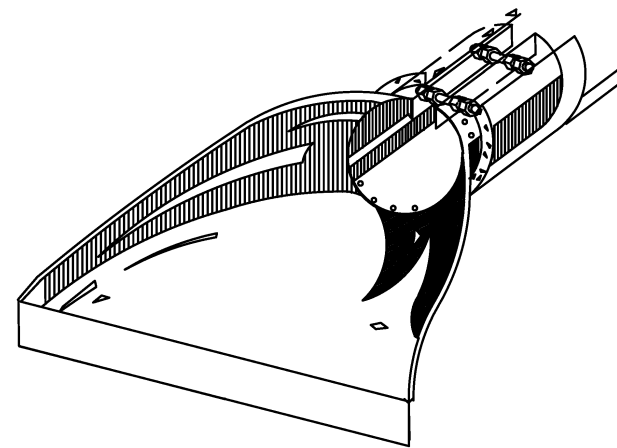

FOR CONNECTING CONCRETE PIPE OR CORRUGATED
POLYETHYLENE PIPE TO METAL END SECTION.

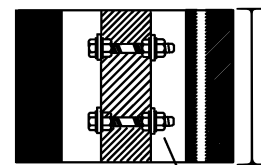

SEE NOTE 2

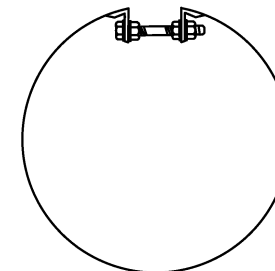

5/8" GALV. BOLTS

METAL INSERTS FOR USE WITH CORRUGATED PLASTIC
PIPE AND
METAL END SECTIONS

State of Alaska DOT&PF
ALASKA STANDARD PLAN

CULVERT END SECTIONS

Adopted as an Alaska
Standard Plan by:

Kenneth J. Fisher
Kenneth J. Fisher, P.E.
Chief Engineer

Adoption Date: 02/08/2019

Last Code and Stds. Review
By: Date:

Next Code and Standards Review date: 02/08/2029

GENERAL NOTES

1. Plastic flared end sections may be used with HDPE corrugated culvert pipes where noted in project plans or approved by project engineer.
2. Consult manufacturer's recommendations for proper sizing and coupling devices. Recommended fasteners may include connecting bands or cinch ties. Fittings across dimension B may include threaded rods with wing nuts or bolts and washers. plastic welds may be recommended.
3. Align coupling to accommodate pipe corrugations.
4. Metal components e.g. bolts or washers must be galvanized.
5. Attachment of end section should preserve culvert alignment and not impair pipe function. Use end sections only on culvert inlet.
6. Toe plate extensions will be required only when designated on the plans.
7. End sections will not be used on HDPE culvert pipes larger than 36" unless indicated by project plans or approved by the Engineer.

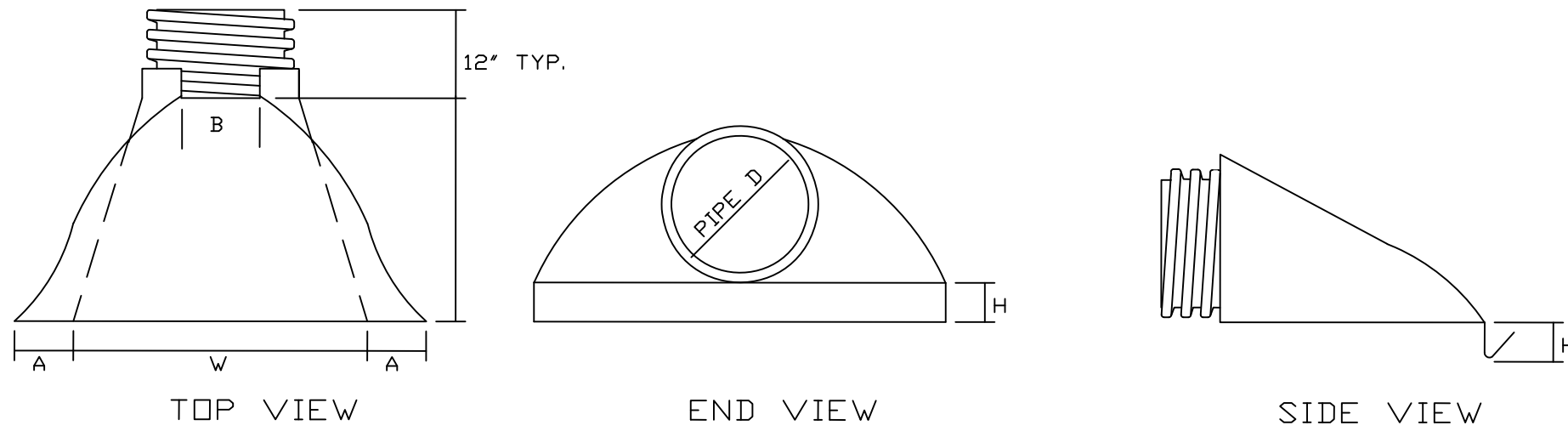

PIPE DIAMETER	DIMENSIONS IN MILLIMETERS				
	A(1"±)	B MAX	H(1"±)	L(1/2"±)	W(2"±)
12" and 15"	6 1/2"	10"	6 1/2"	25"	29"
18"	7 1/2"	15"	6 1/2"	32"	35"
24"	7 1/2"	18"	6 1/2"	36"	45"
30"	10 1/2"	N/A	7"	53"	68"
36"	10 1/2"	N/A	7"	53"	68"

PLASTIC END SECTION FOR CORRUGATED PLASTIC PIPE

State of Alaska DOT&PF
ALASKA STANDARD PLAN

CULVERT END SECTIONS

Adopted as an Alaska
Standard Plan by: *Kenneth J. Fisher*
Kenneth J. Fisher, P.E.
Chief Engineer

Adoption Date: 02/08/2019

Last Code and Stds. Review
By: Date:

Next Code and Standards Review date: 02/08/2029

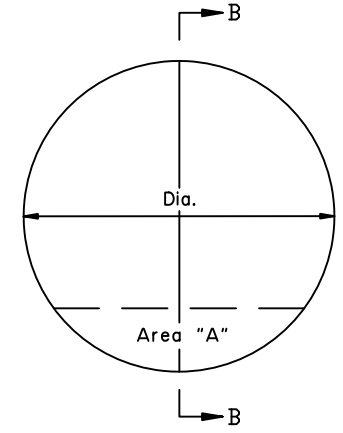
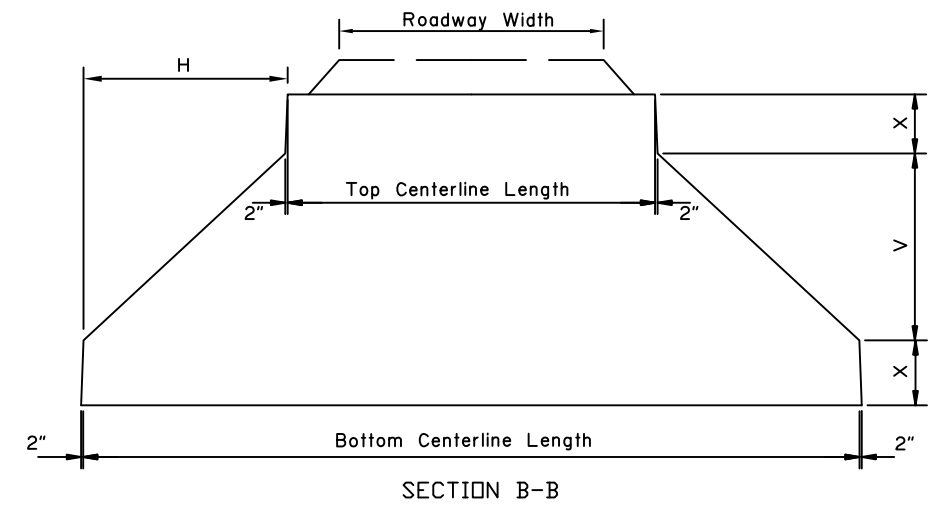
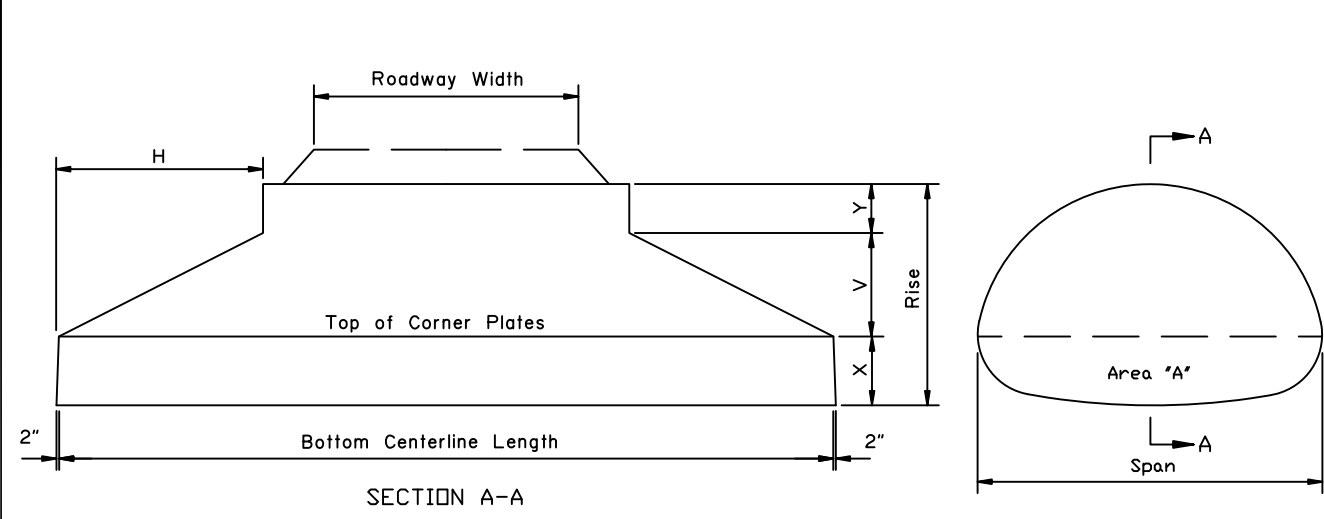

STRUCTURAL PLATE PIPE ARCH

SPAN	RISE	X in ft.	'H' in Feet For Bevels of			'Y' in Feet For Bevels of			'V' in Feet For Bevels of			AREA "A" Sq. Ft.	
			1 1/2:1	2:1	3:1	1 1/2:1	2:1	3:1	1 1/2:1	2:1	3:1		
6'- 1"	4'- 7"	2.3			6.0			0.3			2.0	12	
6'- 4"	4'- 9"	2.1			6.0			0.7			2.0	11	
6'- 9"	4'- 11"	2.4			6.0			0.5			2.0	14	
7'- 0"	5'- 1"	2.3			6.0			0.8			2.0	13	
7'- 3"	5'- 3"	2.1		6.0	6.0			0.2	1.2		3.0	14	
7'- 8"	5'- 5"	2.3		6.0	6.0			0.1	1.1		3.0	16	
7'-11"	5'- 7"	2.2		6.0	6.0			0.4	1.4		3.0	15	
8'- 2"	5'- 9"	2.0		6.0	6.0			0.8	1.8		3.0	15	
8'- 7"	5'- 11"	2.3		6.0	6.0			0.6	1.6		3.0	17	
8'-10"	6'- 1"	2.2		6.0	6.0			0.9	1.9		3.0	17	
9'- 4"	6'- 3"	2.4		6.0	6.0			0.9	1.9		3.0	19	
9'- 6"	6'- 5"	2.3	6.0	6.0	6.0		0.1	1.1	2.1	4.0	3.0	2.0	20
9'- 9"	6'- 7"	2.2	6.0	6.0	6.0		0.4	1.4	2.4	4.0	3.0	2.0	19
10'- 3"	6'- 9"	2.4	6.0	6.0	6.0		0.4	1.4	2.4	4.0	3.0	2.0	22
10'- 8"	6'- 11"	2.8	6.0	6.0	6.0		0.1	1.1	2.1	4.0	3.0	2.0	25
10'-11"	7'- 1"	2.6	6.0	6.0	6.0		0.5	1.5	2.5	4.0	3.0	2.0	24
11'- 5"	7'- 3"	2.8	6.0	6.0	6.0		0.5	1.5	2.5	4.0	3.0	2.0	27
11'- 7"	7'- 5"	2.7	6.0	6.0	8.0		0.7	1.7	2.0	4.0	3.0	2.7	26
11'-10"	7'- 7"	2.5	6.0	6.0	8.0		1.1	2.1	2.4	4.0	3.0	2.7	26
12'- 4"	7'- 9"	2.8	6.0	6.0	8.0		1.0	1.9	2.3	4.0	3.0	2.7	29
12'- 6"	7'- 11"	2.7	6.0	6.0	8.0		1.2	2.2	2.5	4.0	3.0	2.7	29
12'- 8"	8'- 1"	2.5	6.0	8.0	8.0		1.6	1.6	2.9	4.0	4.0	2.7	27
12'-10"	8'- 4"	2.3	6.0	8.0	8.0		2.0	2.0	3.3	4.0	4.0	2.7	25
13'- 5"	8'- 5"	2.6	6.0	8.0	8.0		1.8	1.8	3.1	4.0	4.0	2.7	30
13'-11"	8'- 7"	2.9	6.0	8.0	8.0		1.7	1.7	3.0	4.0	4.0	2.7	34
14'- 1"	8'- 9"	2.8	6.0	8.0	8.0		2.0	2.0	3.2	4.0	4.0	2.7	33
14'- 3"	8'- 11"	2.6	6.0	8.0	8.0		2.3	2.3	3.6	4.0	4.0	2.7	32
14'-10"	9'- 1"	2.9	6.0	8.0	8.0		2.2	2.2	3.5	4.0	4.0	2.7	37
15'- 4"	9'- 3"	3.2	6.0	8.0	8.0		2.1	2.1	3.4	4.0	4.0	2.7	40
15'- 6"	9'- 5"	3.0	6.0	8.0	12.0		2.4	2.4	2.4	4.0	4.0	4.0	39
15'- 8"	9'- 7"	2.8	6.0	8.0	12.0		2.8	2.8	2.8	4.0	4.0	4.0	38
15'-10"	9'- 10"	2.7	8.0	8.0	14.0		1.8	3.1	2.4	5.3	4.0	4.7	35
16'- 5"	9'- 11"	3.0	8.0	8.0	14.0		1.6	2.9	2.2	5.3	4.0	4.7	41
16'- 7"	10'- 1"	2.8	8.0	8.0	14.0		2.0	3.3	2.6	5.3	4.0	4.7	40

STRUCTURAL PLATE PIPE

Dia. Inches	'H' in Feet For Bevels of			'V' in Feet For Bevels of			'X' in Feet For Bevels of			Area "A" in Sq. Ft.		
	1 1/2:1	2:1	3:1	1 1/2:1	2:1	3:1	1 1/2:1	2:1	3:1	1 1/2:1	2:1	3:1
60	6.0	6.0	8.0	4.0	3.0	2.7	0.5	1.0	1.2	0.7	2.5	3.2
66	6.0	6.0	8.0	4.0	3.0	2.7	0.8	1.2	1.4	1.5	3.7	4.6
72	6.0	8.0	12.0	4.0	4.0	4.0	1.0	1.0	1.0	2.6	3.5	2.8
78	6.0	6.0	12.0	4.0	3.0	4.0	1.2	1.2	1.2	3.9	6.7	4.2
84	6.0	8.0	12.0	4.0	4.0	4.0	1.5	1.5	1.5	5.4	5.6	5.7
90	6.0	8.0	12.0	4.0	4.0	4.0	1.8	1.8	1.8	7.1	7.3	7.5
96	8.0	8.0	16.0	5.3	4.0	5.3	1.4	2.0	1.4	4.9	9.3	5.2
102	8.0	8.0	14.0	5.3	4.0	4.7	1.6	2.2	1.9	6.7	12.0	9.2
108	8.0	8.0	14.0	5.3	4.0	4.7	1.8	2.5	2.2	8.5	13.8	11.4
114	8.0	14.0	14.0	5.3	7.0	4.7	2.1	1.2	2.4	10.7	5.0	13.8
120	8.0	14.0	18.0	5.3	7.0	6.0	2.4	1.5	2.0	13.0	6.8	10.7
126	8.0	14.0	18.0	5.3	7.0	6.0	2.6	1.8	2.2	15.5	8.9	13.1
132	12.0	14.0	18.0	8.0	7.0	6.0	1.5	2.0	2.5	6.9	11.1	15.7
138	12.0	16.0	24.0	8.0	8.0	8.0	1.8	1.8	1.8	9.1	9.3	9.5
144	12.0	12.0	20.0	8.0	6.0	6.7	2.0	3.0	2.6	11.4	21.2	18.2
150	12.0	16.0	24.0	8.0	8.0	8.0	2.2	2.2	2.2	14.0	14.2	14.5
156	12.0	16.0	24.0	8.0	8.0	8.0	2.5	2.5	2.5	16.8	17.0	17.3
162	12.0	16.0	24.0	8.0	8.0	8.0	2.8	2.8	2.8	19.6	20.1	20.4
168	14.0	14.0	22.0	9.3	7.0	7.3	2.4	3.5	3.3	15.8	29.1	27.4
174	14.0	14.0	24.0	9.3	7.0	8.0	2.6	3.8	3.2	18.8	32.8	26.9
180	12.0	16.0	24.0	8.0	8.0	8.0	3.5	3.5	3.5	31.1	30.3	30.7

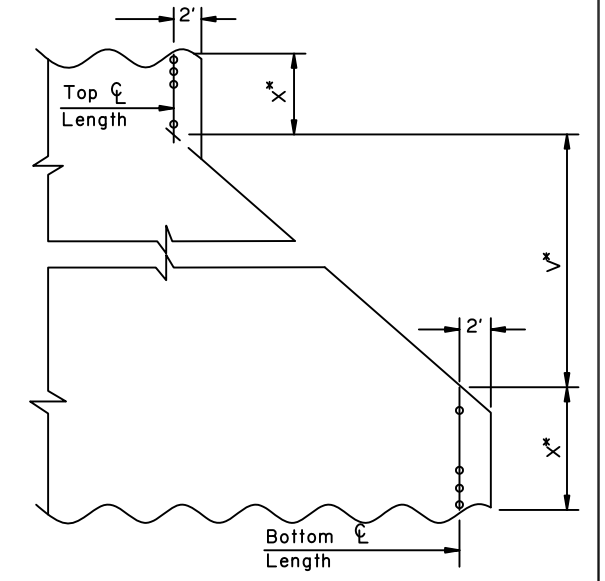

* For elliptical pipe, increase vertical dimensions by percent of ellipse.

State of Alaska DOT&PF
ALASKA STANDARD PLAN

CULVERT BEVELS

Adopted as an Alaska Standard Plan by: *Kenneth J. Fisher*
Kenneth J. Fisher, P.E.
Chief Engineer

Adoption Date: 02/08/2019

Last Code and Stds. Review By: Date:

Next Code and Standards Review date: 02/08/2029

ANNULAR BAND				
BAND MATERIAL	PIPE DIA.	PIPE-ARCH SPAN x RISE (IN.)	BAND AND CONNECTOR WIDTH (W)	BOLT QUANTITY SEE NOTE 2
STEEL	12" - 30"	17x13 TO 35x24	12"	2
	36" - 72"	49x29 TO 83x57	24"	5/6, 10/12
	54" - 144" SEE NOTE 1	NOT APPROPRIATE		10/12, 15/18
ALUMINUM ALLOY	12" - 30"	17x13 TO 35x24	12"	3
	36" - 54"	42x29 TO 64x43	24"	5/6, 10/12
	36" - 96" SEE NOTE 1	NOT APPROPRIATE		

ANNULAR BAND NOTES:

1. TYPICALLY 3" X 1" OR 5" X 1" CORRUGATION SIZES.
2. STACKED BOLT QUANTITY INDICATES NUMBER OF BOLTS FOR ANGLE CONNECTORS THAT ARE ONE OR TWO PIECED. EX 5/6 USES 5 BOLTS FOR SINGLE ANGLE OR 6 BOLTS TOTAL FOR TWO PIECE ANGLE.
3. 8" CONNECTOR MAY BE USED WITH A 12" BAND ON 12"-30" STEEL PIPES.
4. NEOPRENE GASKET 12" WIDE X 3/8" THICK.
5. BOLTS ARE 1/2" X 6" MIN, 1/2" X 8" PREFERRED.

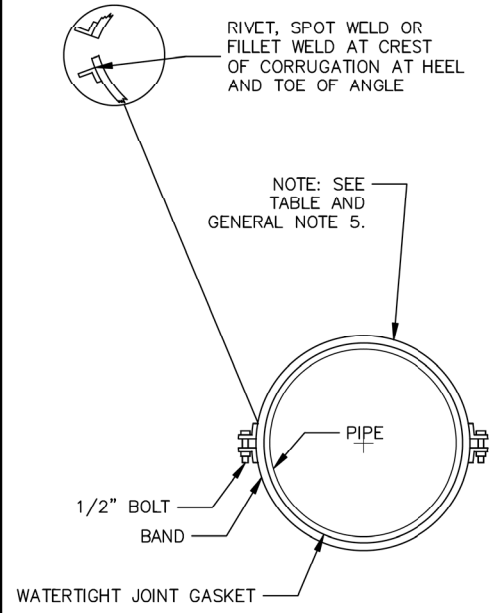

SPIRAL/HELICAL ANGLE BAND			
BAND MATERIAL	PIPE DIA.	BAND AND CONNECTOR WIDTH (W)	BOLT QUANTITY SEE NOTE 2
STEEL	12" - 30"	12"	3/6
	36" - 144" SEE NOTE 1	24"	5/6, 10/12, 15/18
ALUMINUM ALLOY	12" - 30"	12"	3/6
	36" - 54"	12"	5/6, 10/12
	36" - 96" SEE NOTE 1	24"	5/6, 10/12

SPIRAL BAND NOTES:

1. TYPICALLY 3" X 1" OR 5" X 1" CORRUGATION SIZES.
2. STACKED BOLT QUANTITY INDICATES NUMBER OF BOLTS FOR ANGLE CONNECTORS THAT ARE ONE OR TWO PIECED. EX 5/6 USES 5 BOLTS FOR SINGLE ANGLE OR 6 BOLTS TOTAL FOR TWO PIECE ANGLE.
3. NEOPRENE GASKET 12" WIDE X 3/8" THICK.
4. BOLTS ARE 1/2" X 6" MIN, 1/2" X 8" PREFERRED.

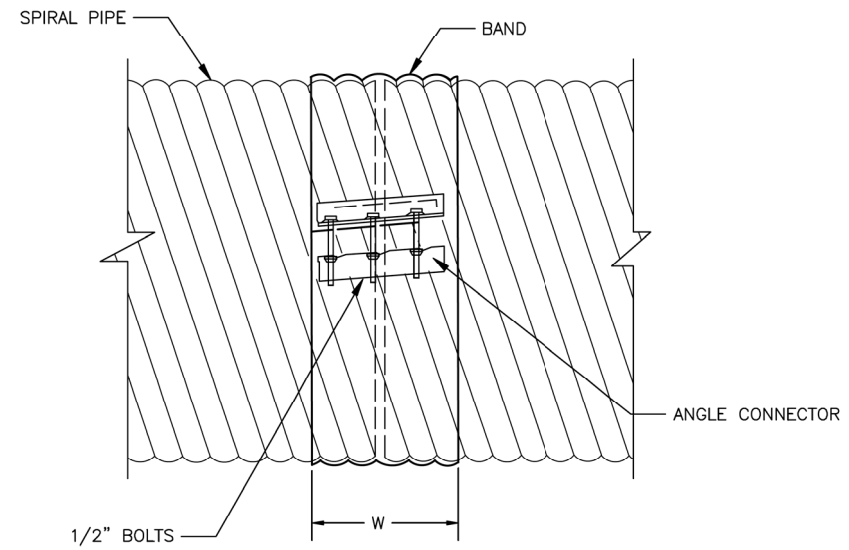

SPIRAL BAND

CORRUGATED BANDS

N.T.S.

SPIRAL/HELICAL BIAS BAND			
BAND MATERIAL	PIPE DIA.	BAND AND CONNECTOR WIDTH (W)	BOLT QUANTITY
STEEL	6" - 10"	7"	2
	12" - 18"	12"	3
ALUMINUM ALLOY	6" - 10"	7"	2
	12" - 18"	12"	3

2-PIECE BIAS BAND NOTES:

1. NEOPRENE GASKET 7" WIDE X 3/8" THICK.

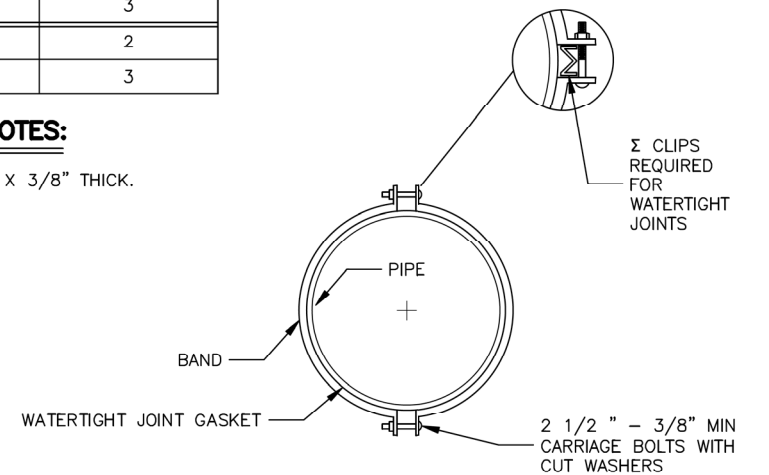

BIAS BAND END VIEW

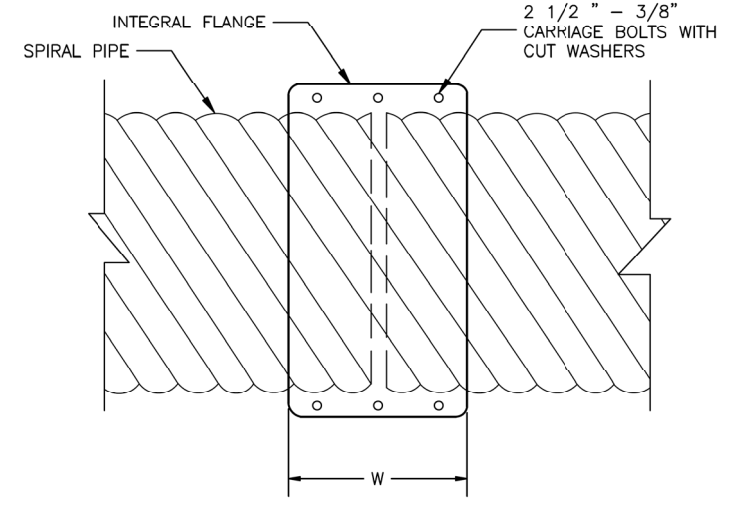

2-PIECE BIAS BAND

ANGLE CONNECTOR DETAIL

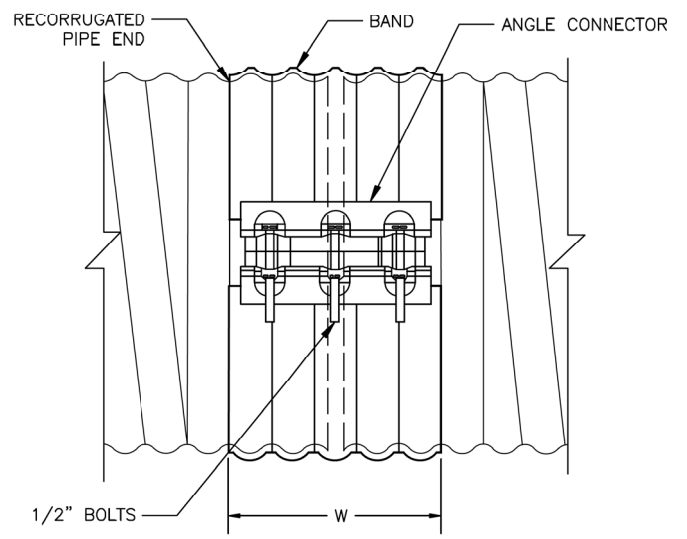

ANNULAR BAND

GENERAL NOTES:

1. ALL MATERIAL AND WORKMANSHIP SHALL BE IN ACCORDANCE WITH THE STATE OF ALASKA, STANDARD SPECIFICATIONS FOR HIGHWAY CONSTRUCTION, AND THE PROJECT SPECIAL PROVISIONS.
2. ALL NEOPRENE GASKETS ARE STRIP TYPE OR BUTT-CEMENTED OR VULCANIZED SLEEVE TYPE. MATERIAL MEETS ASTM SPECIFICATION D 1056, TYPE 2 (CLOSED CELL SPONGE), CLASS D, GRADE 3. O-RING GASKETS TO MEET SPECIFICATION ASTM C-443.
3. BAND ANGLE LENGTH IS NOMINAL AND IS GIVEN TO THE NEAREST INCH OF LENGTH. LENGTH OVER 12" MAY CONSIST OF MULTIPLE ANGLES OF SHORTER LENGTH.
4. BOLT QUANTITY VARIES WITH BAND WIDTH, DIAMETER, CONNECTION HARDWARE TYPE, AND NUMBER OF BAND SEGMENTS.
5. PROVIDE ONE-PIECE ANGLE CONNECTOR THRU 42" DIAMETER, 2-PIECE ANGLE CONNECTORS FOR DIAMETERS 48" THRU 90", AND THREE-PIECE ANGLE CONNECTORS FOR DIAMETERS 96" THRU 144", OR AS OTHERWISE REQUESTED.

State of Alaska DOT&PF
ALASKA STANDARD PLAN
**BAND COUPLER AND
HARDWARE SCHEDULE**

Adopted as an Alaska Standard Plan by: 
Lauren Little, P.E.
Interim Chief Engineer

Adoption Date: 01/29/2024

Last Code and Stds. Review
By: BMM Date: 12/13/2023

Next Code and Standards Review Date: 12/13/2033

D-08.00

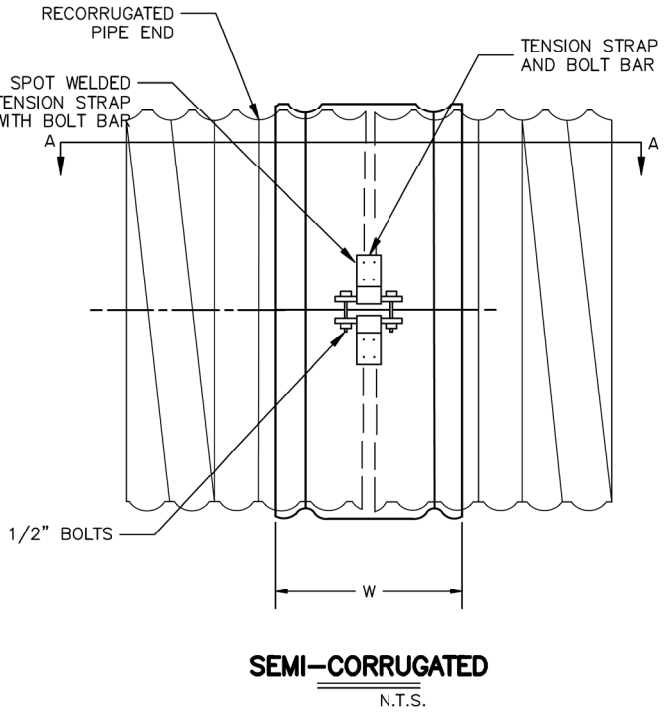
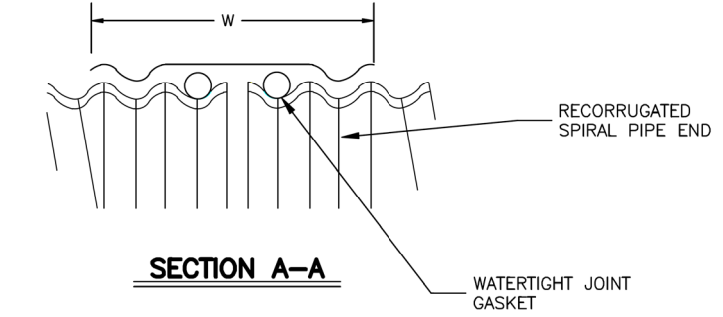
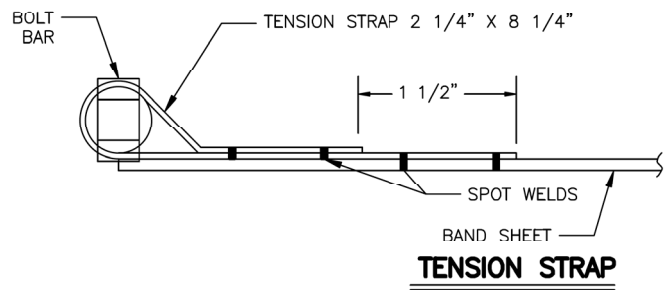

- SEMI-CORRUGATED BAND NOTES:**
- ANNULAR PIPE WIDTH 2 2/3" X 1/2" CORRUGATIONS WIDTH IS 13 3/8", FOR 3"x1" CORRUGATIONS WIDTH IS 14 3/4"
 - BOLTS ARE 1/2" X 6" MIN, 1/2" X 8" PREFERRED.
 - ALTERNATE DESIGNS OF TENSIONS STRAPS ARE PERMISSIBLE IF TENSILE STRENGTH EXCEEDS 7500 LBS.

TYPE 1 BAND					
BAND MATERIAL	PIPE DIA.	PIPE-ARCH SPAN x RISE (IN.)	BAND WIDTH (W)	CONNECTOR WIDTH (W)	BOLT QUANTITY SEE NOTE 2
STEEL	12" - 30"	17x13 TO 35x24	10 1/2"	8"	2/4
	36" - 72"	49x29 TO 83x57	21"	20"	5/10
	54" - 144" SEE NOTE 1	NOT APPROPRIATE			10/15
ALUMINUM ALLOY	12" - 30"	17x13 TO 35x24	10 1/2"	8"	2/4
	36" - 54"	42x29 TO 64x43	21"	20"	5/6, 10/12
	54" - 96" SEE NOTE 1	NOT APPROPRIATE			

- TYPE 1 BAND NOTES:**
- TYPICALLY 3" X 1" OR 5" X 1" CORRUGATION SIZES.
 - STACKED BOLT QUANTITY INDICATES NUMBER OF BOLTS FOR ANGLE CONNECTORS THAT ARE ONE OR TWO PIECED. EX 2/4 USES 2 BOLTS FOR SINGLE ANGLE OR 4 BOLTS TOTAL FOR TWO PIECE ANGLE.
 - NEOPRENE GASKET 12" WIDE X 3/8" THICK.
 - O-RING GASKETS (APPLICABLE TO STEEL ONLY) ARE 13/16" FOR BANDS WITH PIPE DIAMETER THROUGH 72", AND 7/8" FOR PIPES WITH PIPE DIAMETER OVER 72".
 - BOLTS ARE 1/2" X 6" MIN, 1/2" X 8" PREFERRED.

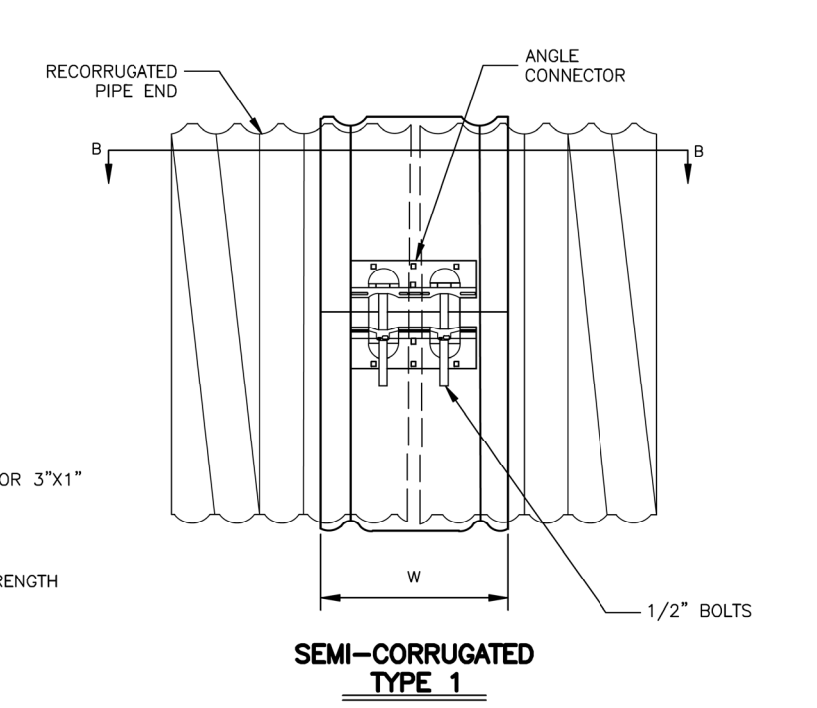
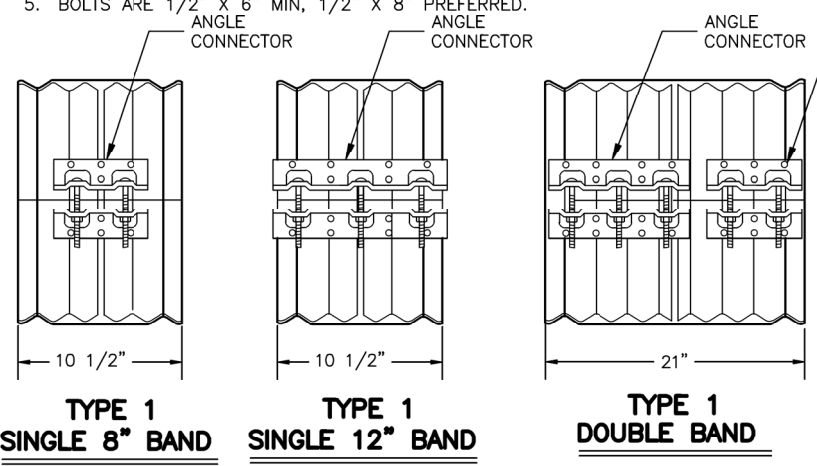

TYPE 2 BAND					
BAND MATERIAL	PIPE DIA.	PIPE-ARCH SPAN x RISE (IN.)	BAND WIDTH (W)	CONNECTOR WIDTH (W)	BOLT QUANTITY SEE NOTE 2
STEEL	12" - 30"	17x13 TO 35x24	10 1/2"	2.25"	2/4
	36" - 72"	49x29 TO 83x57	21"	2.25"x2"	4/8
	54" - 144" SEE NOTE 1	NOT APPROPRIATE			8/12
ALUMINUM ALLOY	12" - 30"	17x13 TO 35x24	10 1/2"	2.25"	2/4
	36" - 54"	42x29 TO 64x43	21"	2.25"x2"	5/6, 10/12
	54" - 96" SEE NOTE 1	NOT APPROPRIATE			

- TYPE 2 BAND NOTES:**
- TYPICALLY 3" X 1" OR 5" X 1" CORRUGATION SIZES.
 - STACKED BOLT QUANTITY INDICATES NUMBER OF BOLTS FOR ANGLE CONNECTORS THAT ARE ONE OR TWO PIECED. EX 2/4 USES 2 BOLTS FOR SINGLE ANGLE OR 4 BOLTS TOTAL FOR TWO PIECE ANGLE.
 - NEOPRENE GASKET 12" WIDE X 3/8" THICK.
 - O-RING GASKETS (APPLICABLE TO STEEL ONLY) ARE 13/16" FOR BANDS WITH PIPE DIAMETER THROUGH 72", AND 7/8" FOR PIPES WITH PIPE DIAMETER OVER 72".
 - BOLTS ARE 1/2" X 6" MIN, 1/2" X 8" PREFERRED.

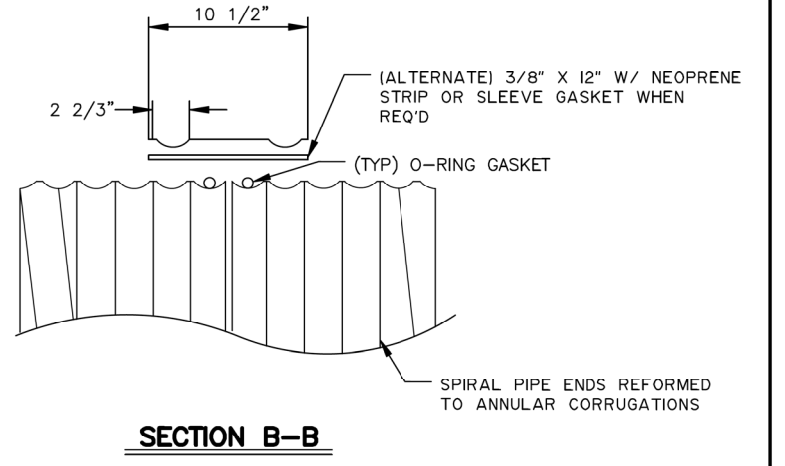
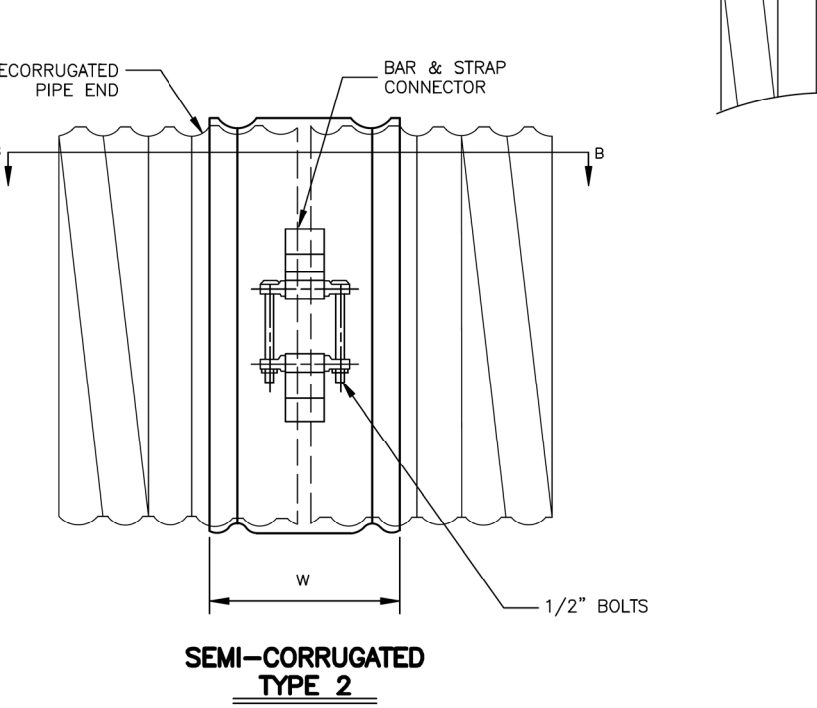
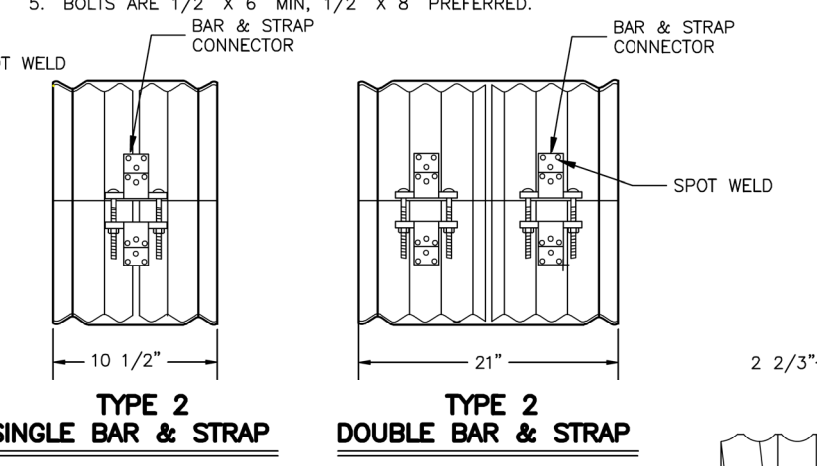

SEMI-CORRUGATED BANDS (TYPE 1 & 2)
N.T.S.

State of Alaska DOT&PF
ALASKA STANDARD PLAN

**BAND COUPLER AND
HARDWARE SCHEDULE**

Adopted as an Alaska Standard Plan by:
Lauren Little, P.E.
Interim Chief Engineer

Adoption Date: 01/29/2024

Last Code and Stds. Review
By: BMM Date: 12/13/2023

Next Code and Standards Review Date: 12/13/2033

D-08.00

DIMPLE BAND				
BAND MATERIAL	PIPE DIA.	PIPE ARCH SPAN x RISE (IN.)	BAND AND CONNECTOR WIDTH (W)	BOLT QUANTITY SEE NOTE 2
STEEL	12" - 30"	17x13 TO 35x24	12"	3/6
	36" - 72"	49x29 TO 83x57	24"	5/6, 10/12
	54" - 144" SEE NOTE 1	42x29 TO 171x110		10/12, 15/18
ALUMINUM ALLOY	12" - 30"	17x13 TO 35x24	12"	3/6
	36" - 54"	42x29 TO 64x43	24"	5/6, 10/12
	36" - 96" SEE NOTE 1	60x46 TO 112x75		

DIMPLE BAND NOTES:

1. TYPICALLY 3" X 1" OR 5" X 1" CORRUGATION SIZES.
2. STACKED BOLT QUANTITY INDICATES NUMBER OF BOLTS FOR ANGLE CONNECTORS THAT ARE ONE OR TWO PIECED. EX 3/6 USES 3 BOLTS FOR SINGLE ANGLE OR 6 BOLTS TOTAL FOR TWO PIECE ANGLE.
3. DIMPLE BANDS ARE RESTRICTED TO JOINING FIELD CUT PIPE, EXTENSIONS OF EXISTING PIPE WITH SPIRAL ENDS, AND 3X1 OR 5X1 CORRUGATION PIPE-ARCHES.
4. NEOPRENE GASKET 12" WIDE X 3/8" THICK EXCEPT 1" THICK REQUIRED ON SPIRAL ENDS WITH 1" DEEP CORRUGATIONS.

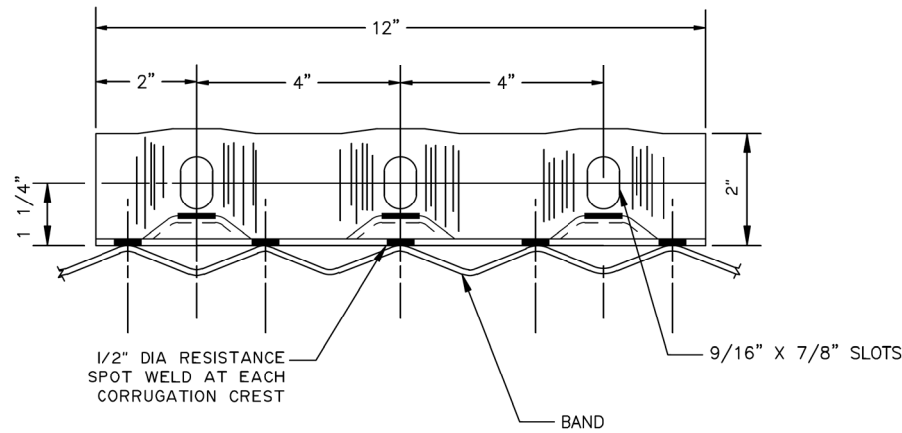

SIDE VIEW

ROD AND LUG BAND				
CORRUGATION	PIPE DIA.	BAND WIDTH (W)	ROD DIAMETER (IN.)	ROD QUANTITY SEE NOTE 2
2 3/4" x 1/2"	12" - 21"	12"	3/8"	2
	24" - 54"	12" OR 24"	1/2"	2/4
	60" - 84"	12" OR 24"	5/8"	2/4
3" x 1"	36" - 54"	14" OR 26"	1/2"	2/4
	60" - 84"	14" OR 26"	5/8"	2/4
	84" - 120"	26"	5/8"	4

ROD AND LUG NOTES:

1. PROVIDE WIDER BAND UNLESS OTHERWISE SPECIFIED.
2. STACKED ROD QUANTITY INDICATES NUMBER OF RODS FOR NARROW OR WIDE BANDS. EX 2/4 USES 2 RODS FOR NARROW BAND OR 4 RODS TOTAL FOR WIDE BANDS.

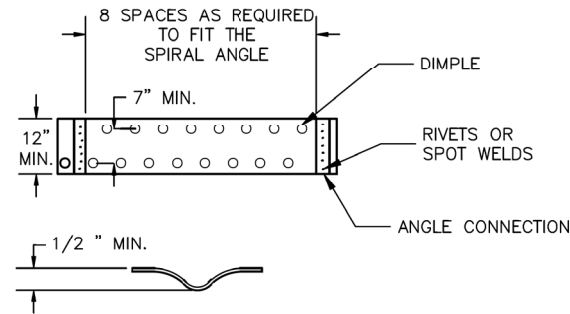

DIMPLE SECTION

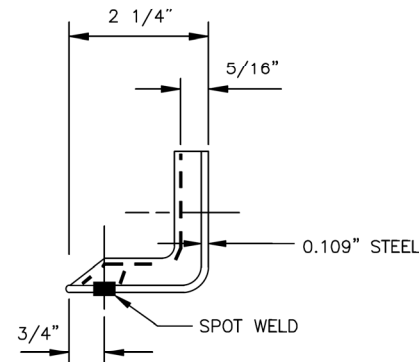

END VIEW

ANGLE CONNECTION DETAILS

N.T.S.

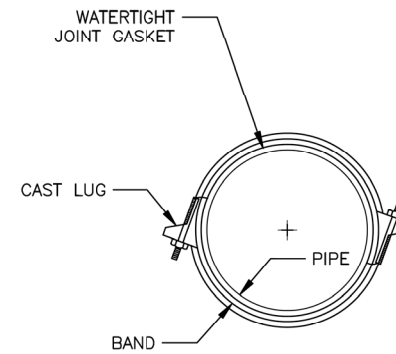

END VIEW

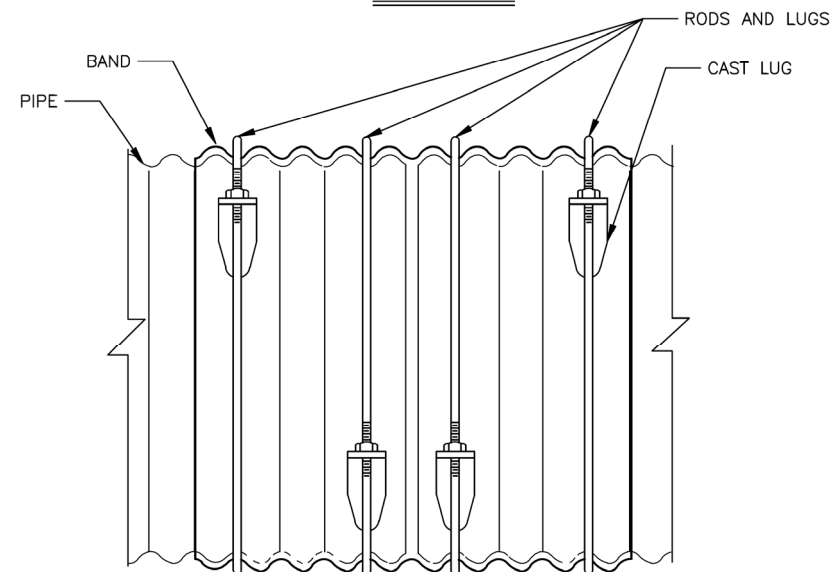

ROD AND LUG BAND DETAILS

N.T.S.

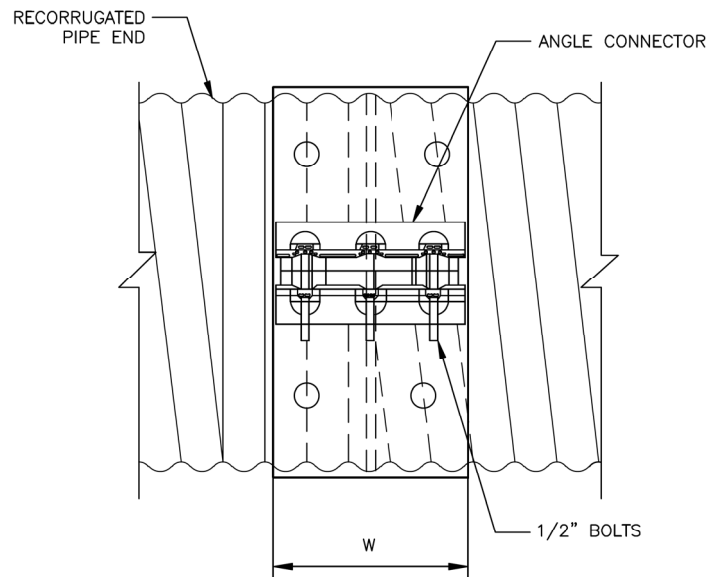

DIMPLE BAND DETAILS

N.T.S.

State of Alaska DOT&PF
ALASKA STANDARD PLAN
**BAND COUPLER AND
HARDWARE SCHEDULE**

Adopted as an Alaska Standard Plan by:

Lauren Little, P.E.
Interim Chief Engineer

Adoption Date: 01/29/2024

Last Code and Stds. Review
By: BMM Date: 12/13/2023

Next Code and Standards Review Date: 12/13/2033

GENERAL NOTES:

- I. Culvert marker post shall be installed with galvanized steel hardware meeting the following requirements: Galvanizing for nuts and washers shall meet the requirements of ASTM A-153, Class C. Galvanizing for steel mounting supports shall meet the requirements of MIL-P-26915A, or ASTM A-153, Class C.

O
 23 + 45
 18" x 48"
 O

Sta. and size of Culvert to be stamped into a 2"x4"x0.064" thick brass plate, fastened, with No. 8 round head brass screws, to the marker post as shown. Plate to be on side of post facing traffic.

DIRECTION OF TRAFFIC

Shoulder of Road

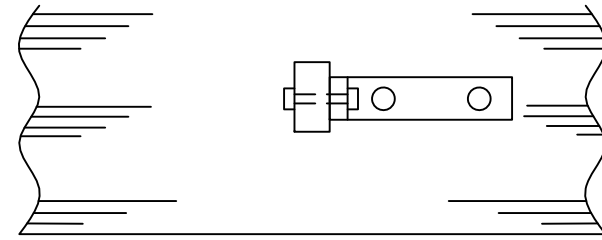

TOP VIEW

* Black Paint, Exterior Grade, Semi Gloss Enamel.

* White Paint, Exterior Grade, Semi Gloss Enamel

* As approved by the Engineer

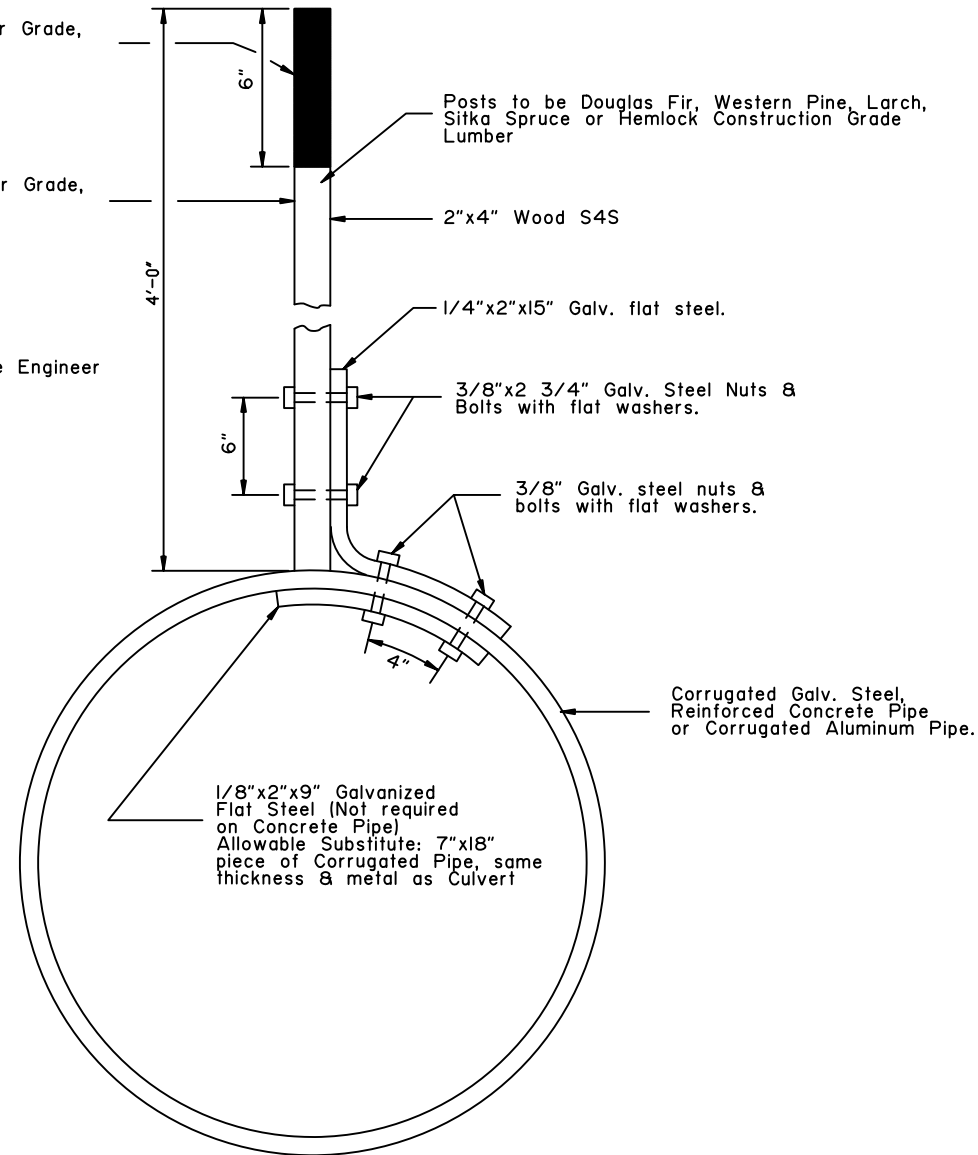

END VIEW

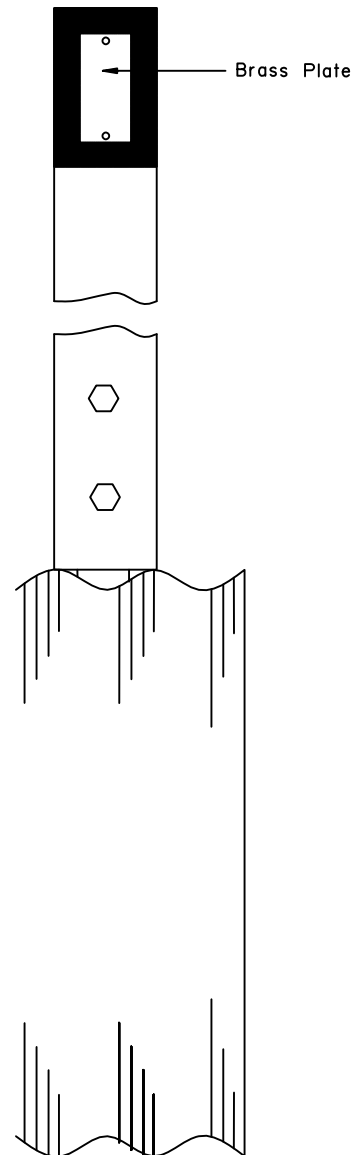

SIDE VIEW

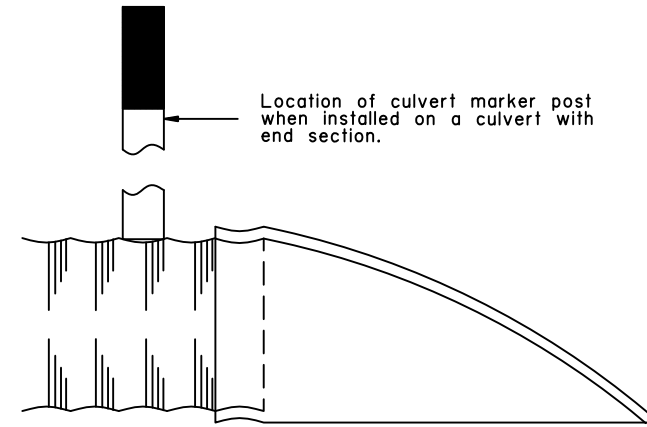

END SECTION SIDE VIEW

State of Alaska DOT&PF
ALASKA STANDARD PLAN

CULVERT MARKER POST

Adopted as an Alaska Standard Plan by:
Kenneth J. Fisher, P.E.
Chief Engineer

Adoption Date: 02/08/2019

Last Code and Stds. Review
By: Date:

Next Code and Standards Review date: 02/08/2029

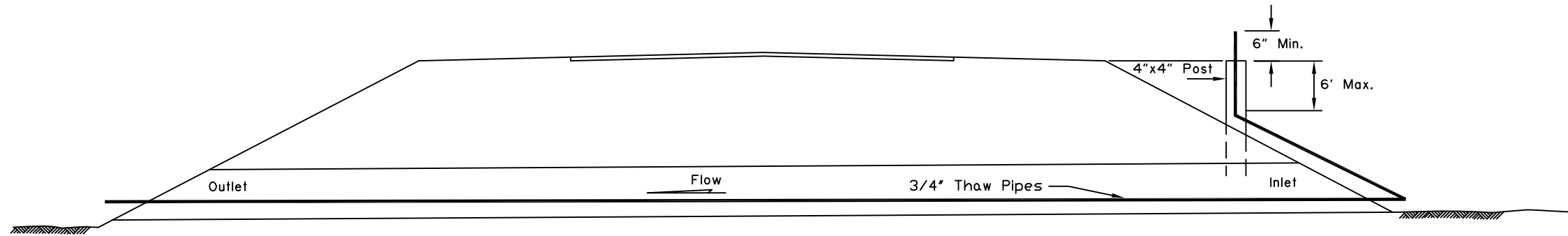

CROSS-SECTION

- GENERAL NOTES:**
1. 3/4" main line and standpipes to be liquid tight and filled with 50-50 antifreeze.
 2. Standpipe support posts to be installed not more than 6'-0" below shoulder.
 3. Thaw pipes to be attached to culvert at inlet and outlet ends and to post.

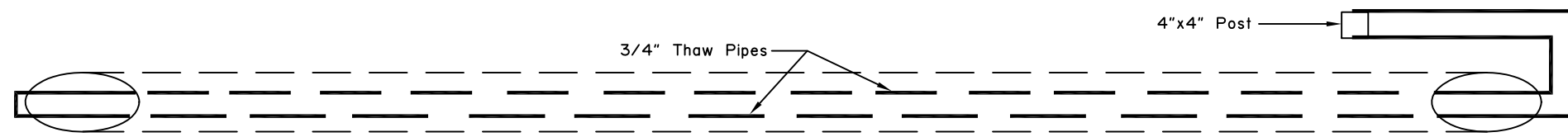

PLAN VIEW

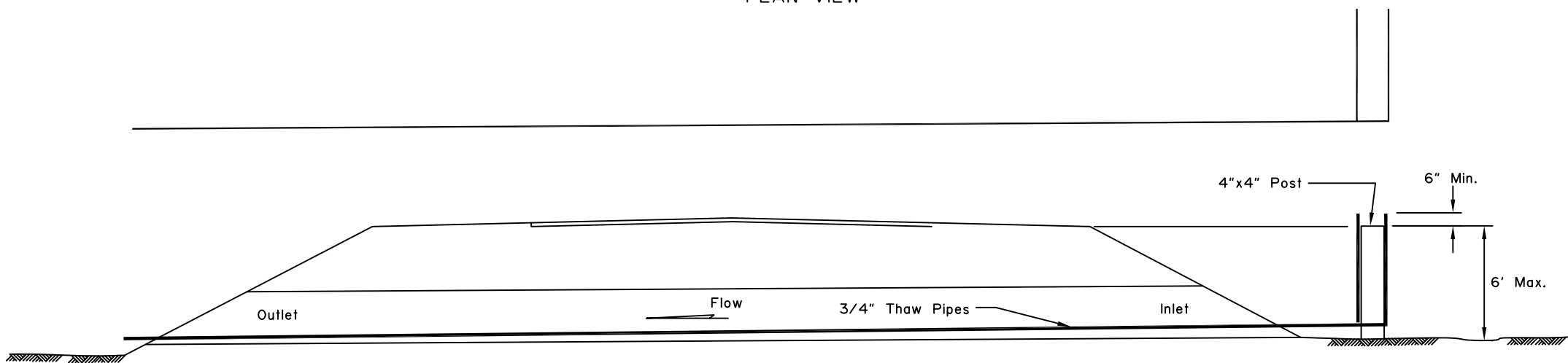

CROSS-SECTION

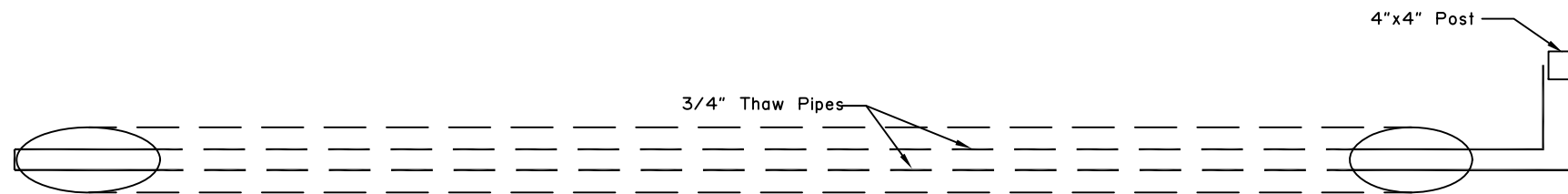

PLAN VIEW

State of Alaska DOT&PF
ALASKA STANDARD PLAN
CULVERT CIRCULATING
THAW PIPE

Adopted as an Alaska
Standard Plan by: *Kenneth J. Fisher*
Kenneth J. Fisher, P.E.
Chief Engineer

Adoption Date: 02/08/2019

Last Code and Stds. Review
By: Date:

Next Code and Standards Review date: 02/08/2029

GENERAL NOTES:

1. Load Center Cabinet shall be located outside of the clear zone and above high water.
2. Caution Sign shall be mounted to the side of treated posts facing highway at the culvert entry and exit and at the Loadcenter Cabinet.
3. See Alaska Highway Preconstruction Manual for 'Clear Zone' requirements.
4. Junction boxes shall be used in place of hand holes at wet locations and shall be mounted at 48" or at 24" above high water if greater than 48".

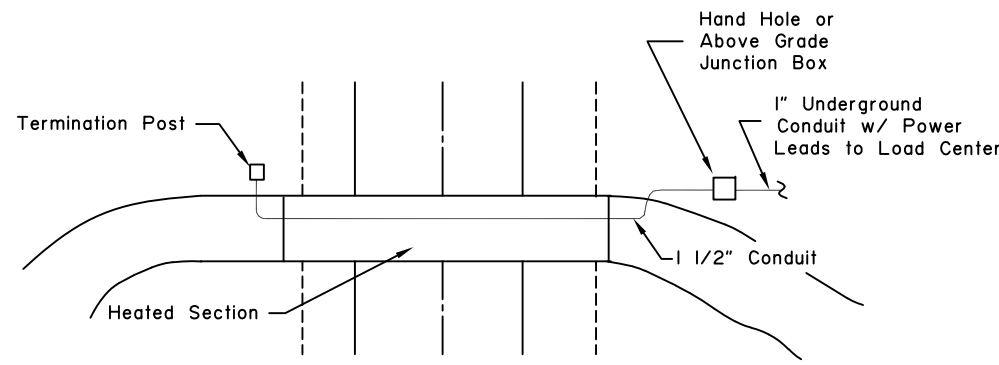

PLAN

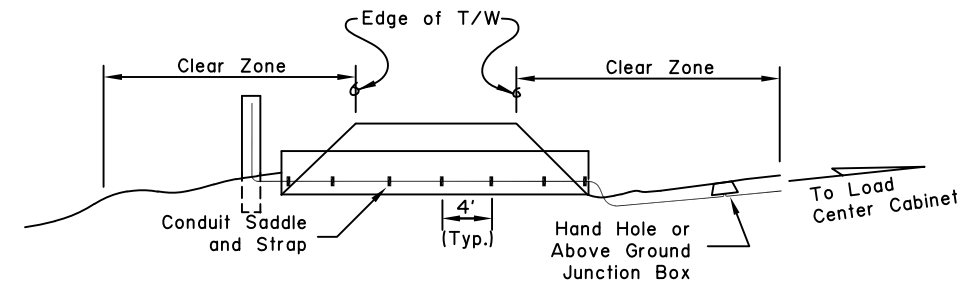

PROFILE

TYPICAL SITE PLAN

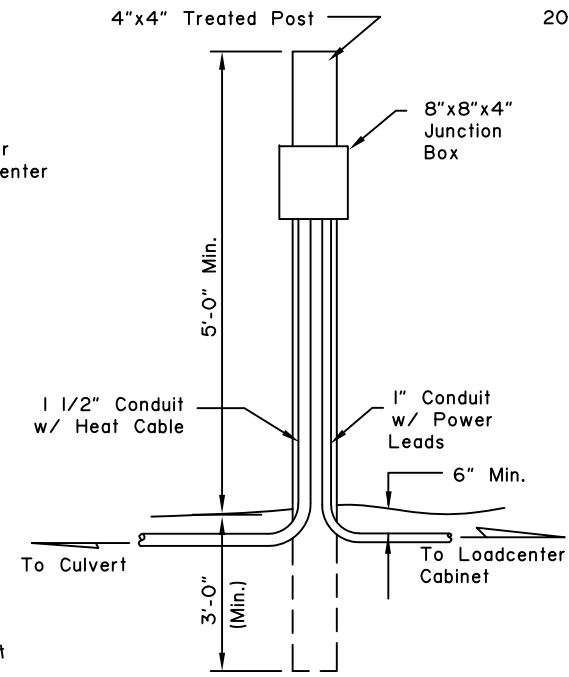

ABOVE GRADE JUNCTION BOX

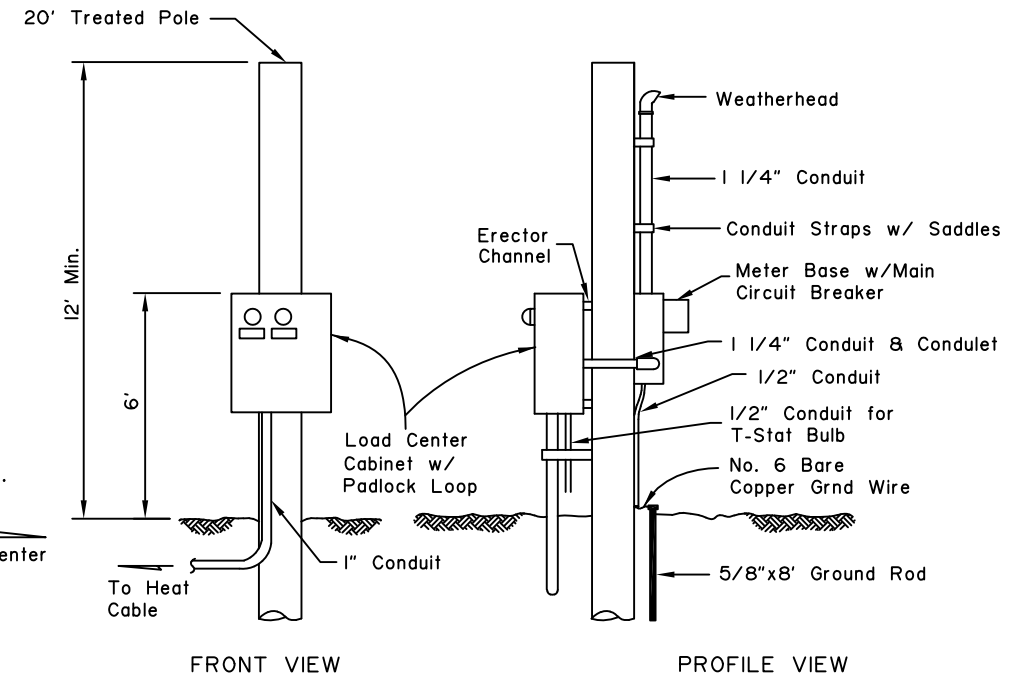

FRONT VIEW

PROFILE VIEW

OVERHEAD SERVICE DETAIL

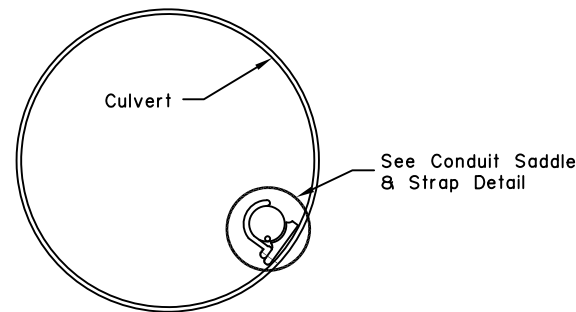

CULVERT CROSS SECTION

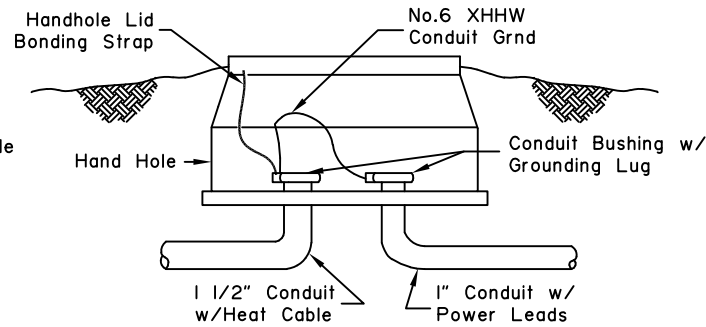

HAND HOLE DETAIL

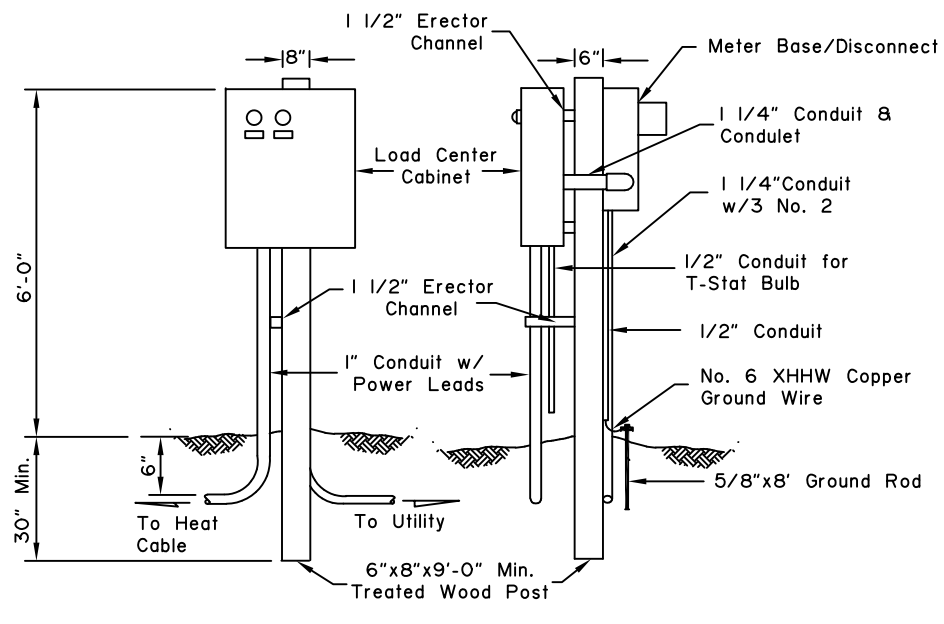

FRONT VIEW

PROFILE VIEW

UNDERGROUND SERVICE DETAIL

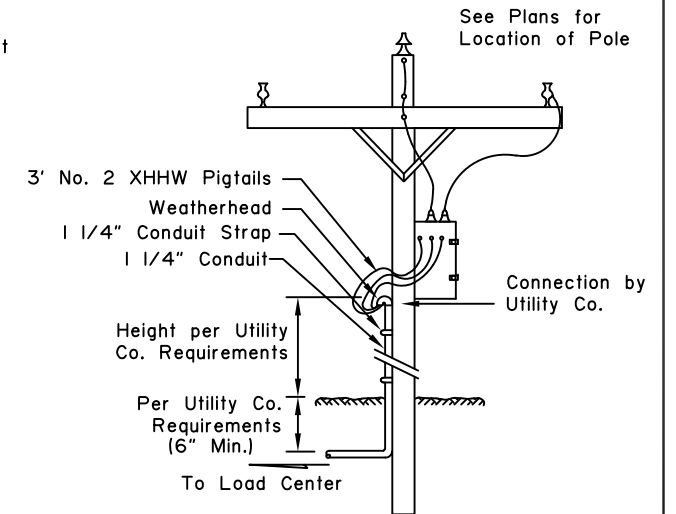

UNDERGROUND SERVICE
POLE RISER DETAIL

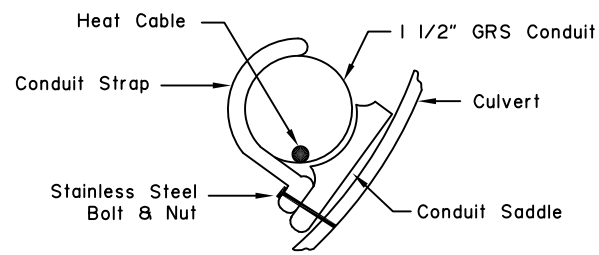

CONDUIT SADDLE &
STRAP DETAIL

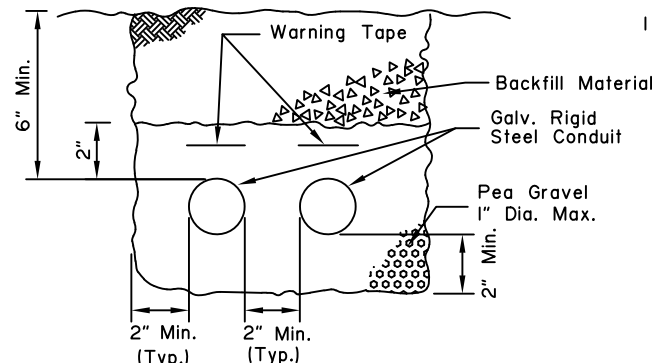

POWER LEAD TRENCH SECTION

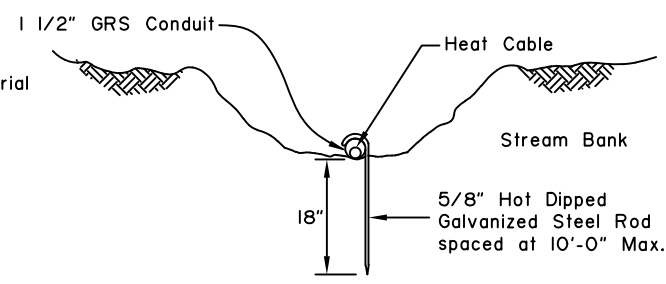

HEAT CABLE TRENCH DETAIL

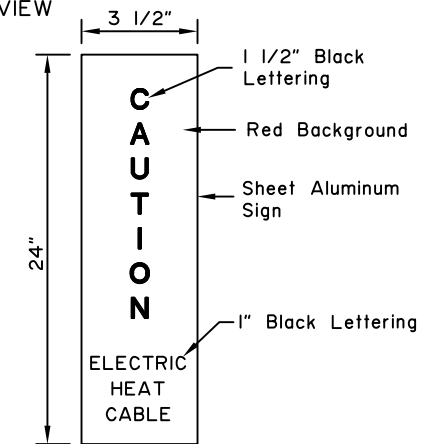

CAUTION SIGN

State of Alaska DOT&PF
ALASKA STANDARD PLAN
CULVERT THAW
WIRE INSTALLATION

Adopted as an Alaska
Standard Plan by: *Kenneth J. Fisher*
Kenneth J. Fisher, P.E.
Chief Engineer

Adoption Date: 02/08/2019

Last Code and Stds. Review
By: Date:

Next Code and Standards Review date: 02/08/2029

GENERAL NOTES:

1. Loadcenter Cabinet panel face shall be placed parallel with the highway.
2. Type FD Cast Device Box w/green pilot light on the termination post shall be located a minimum of 6" above high water.

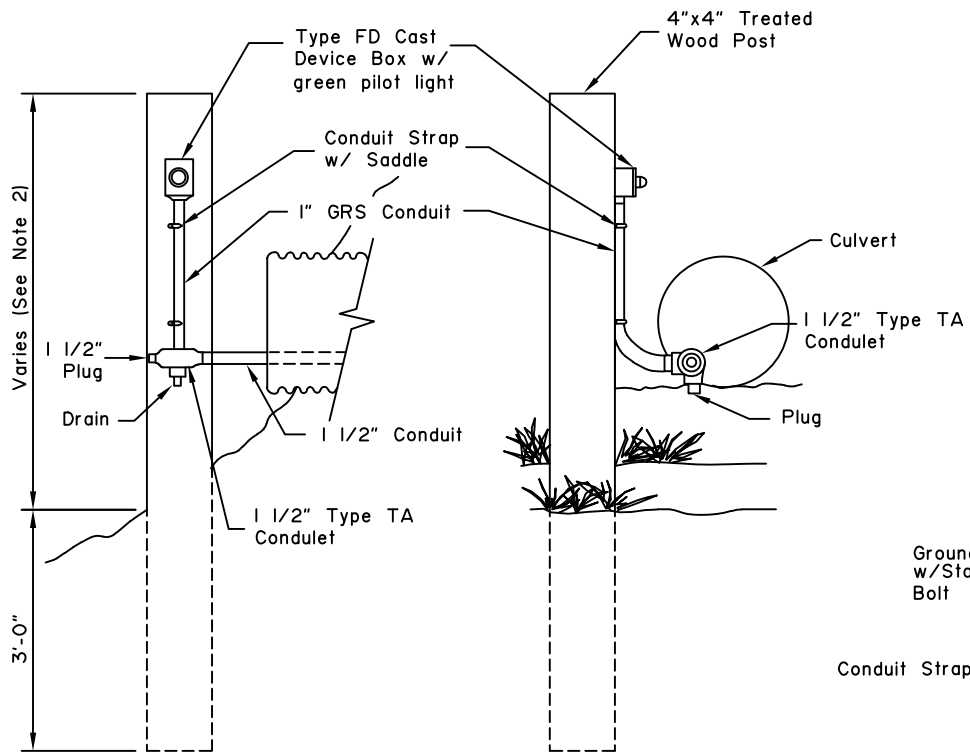

FRONT VIEW PROFILE VIEW
TERMINATION POST DETAIL

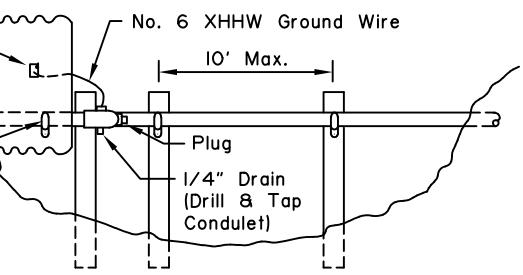
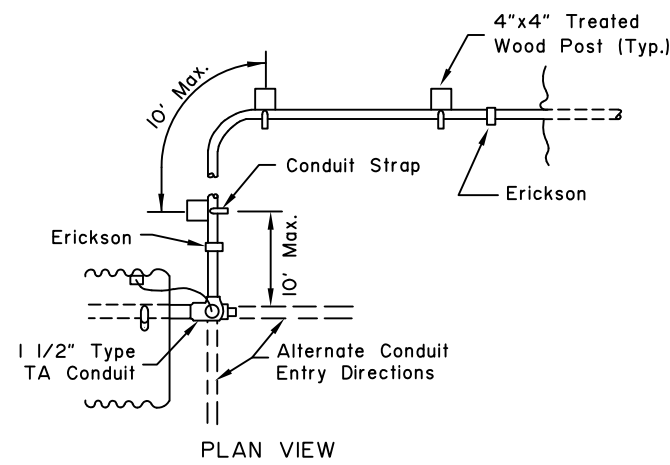

PLAN VIEW
ELEVATION
CULVERT ENTRY DETAIL

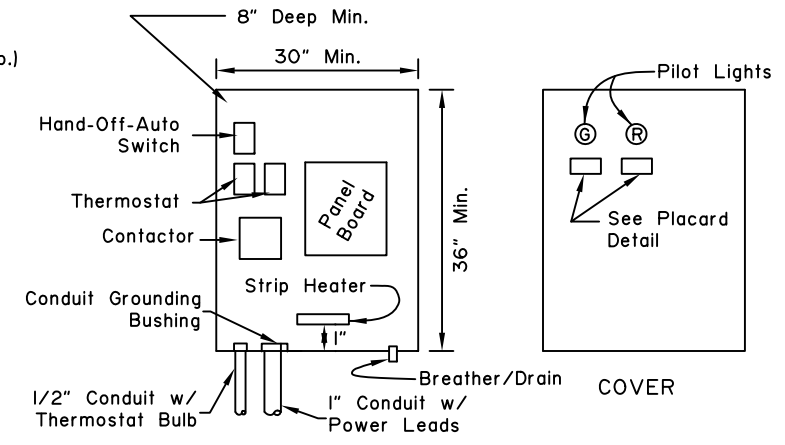

LOAD CENTER CABINET
(NEMA 4 Cabinet w/ Drip Shield)

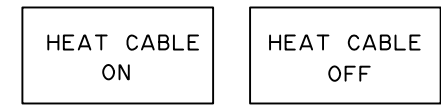

PLACARD DETAIL

SIZE	MAX. LENGTH
15/2	175 Ft.
20/2	240 Ft.
30/2	320 Ft.
40/2	415 Ft.

CIRCUIT BREAKER SIZING TABLE

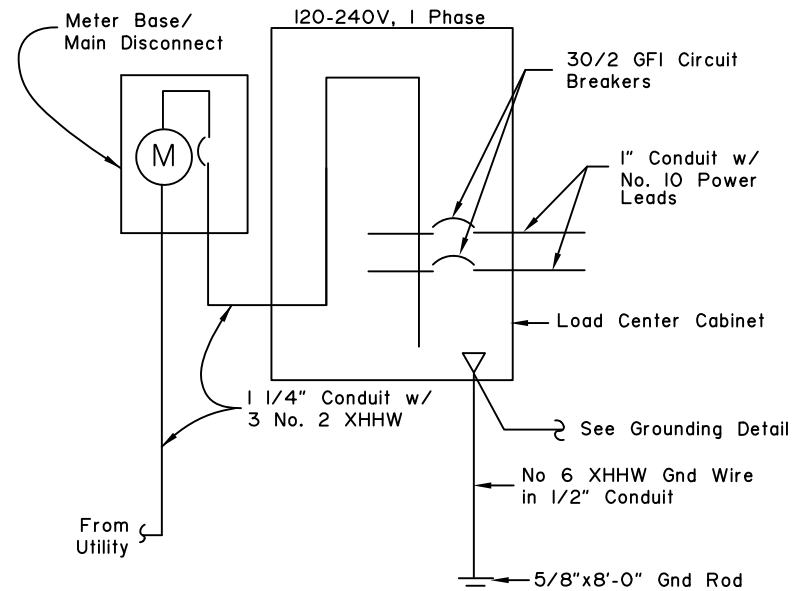

SINGLE LINE DIAGRAM

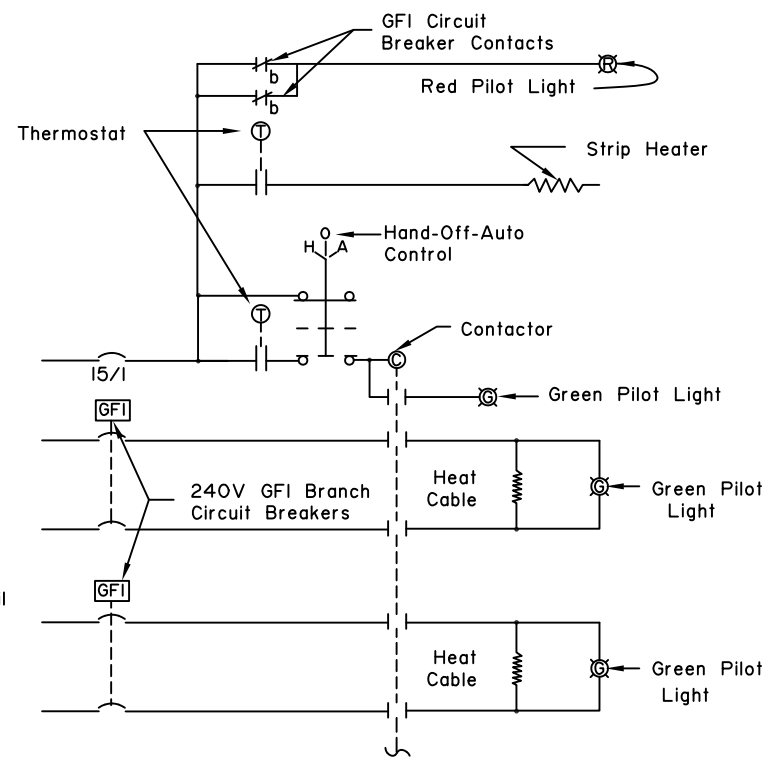

CONTROLS DIAGRAM

NOTE: May use same scheme for other quantities of Heat Cable Circuits.

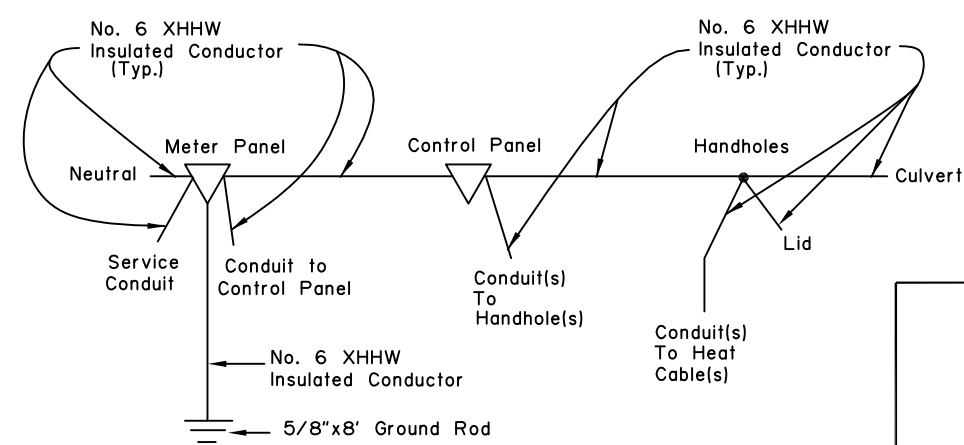

GROUNDING DETAIL

State of Alaska DOT&PF
ALASKA STANDARD PLAN
CULVERT THAW
WIRE INSTALLATION

Adopted as an Alaska Standard Plan by: *Kenneth J. Fisher*
Kenneth J. Fisher, P.E.
Chief Engineer

Adoption Date: 02/08/2019

Last Code and Stds. Review By: Date:

Next Code and Standards Review date: 02/08/2029

GENERAL NOTES:

1. Load Center Cabinet shall be located outside of the clear zone and above high water.
2. Caution Sign shall be mounted to the side of treated posts facing highway at the culvert entry and exit and at the Loadcenter Cabinet.
3. See Alaska Highway Preconstruction Manual for 'Clear Zone' requirements.
4. Junction boxes shall be used in place of hand holes at wet locations and shall be mounted at 48" or at 24" above high water if greater than 48".

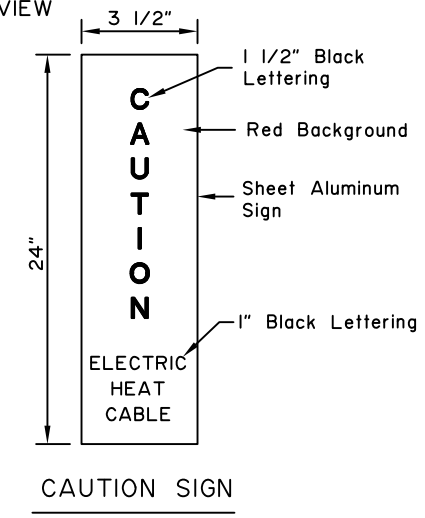
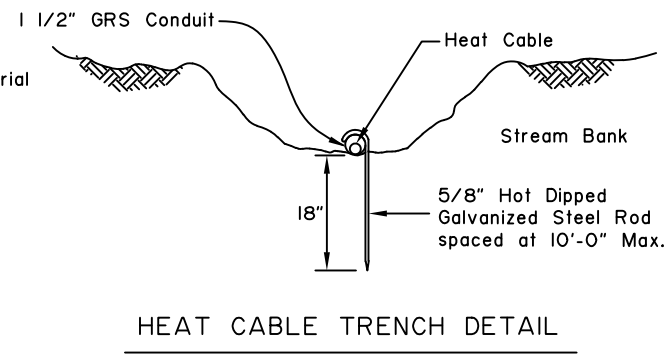
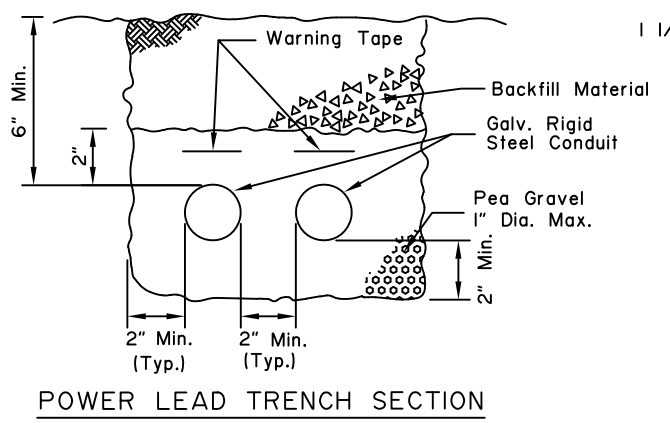
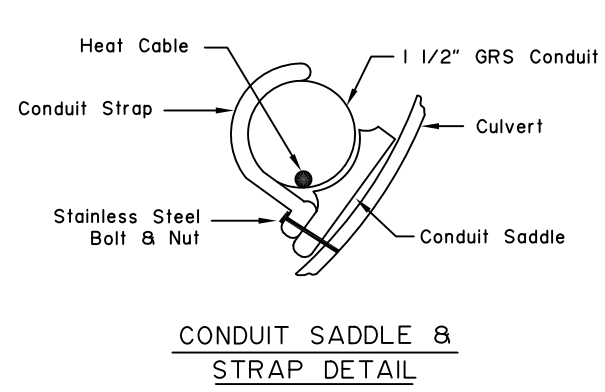
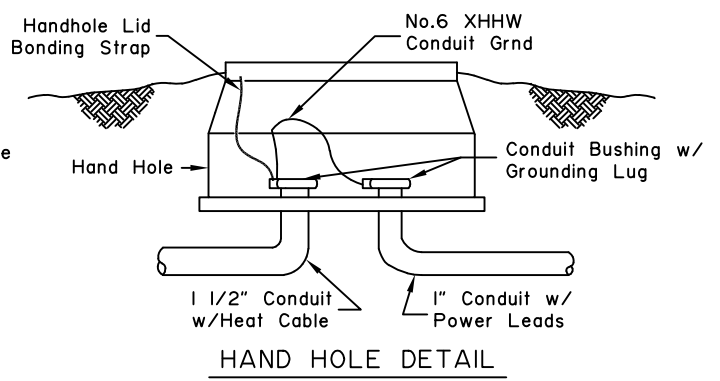
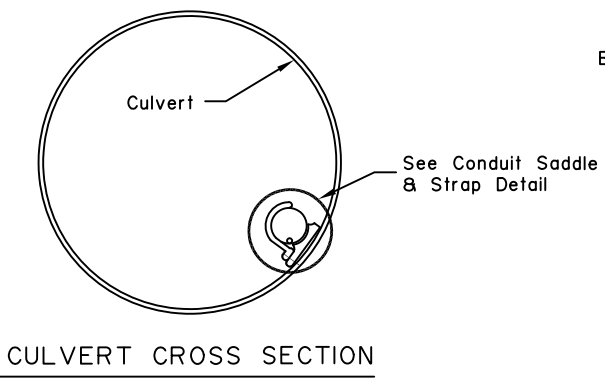
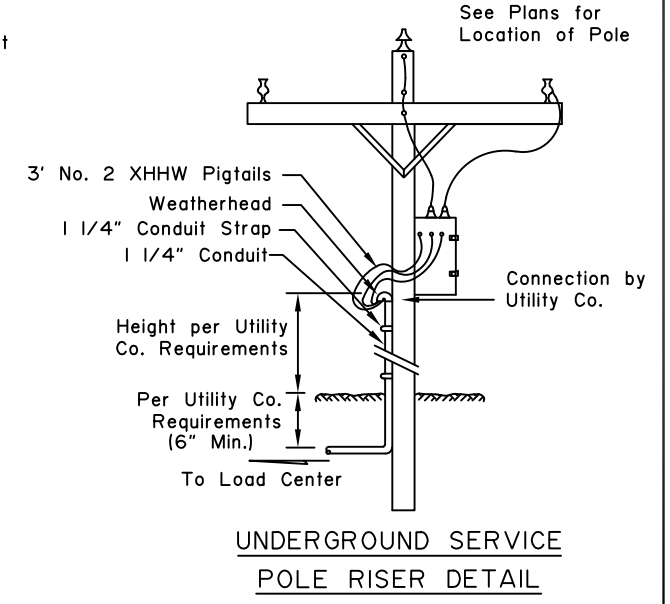
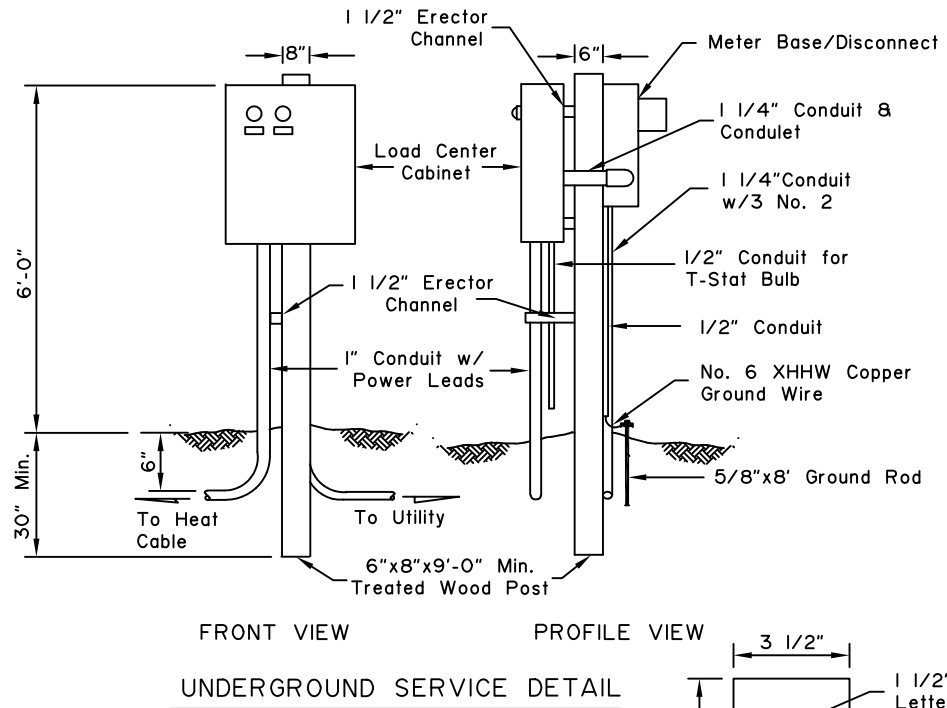
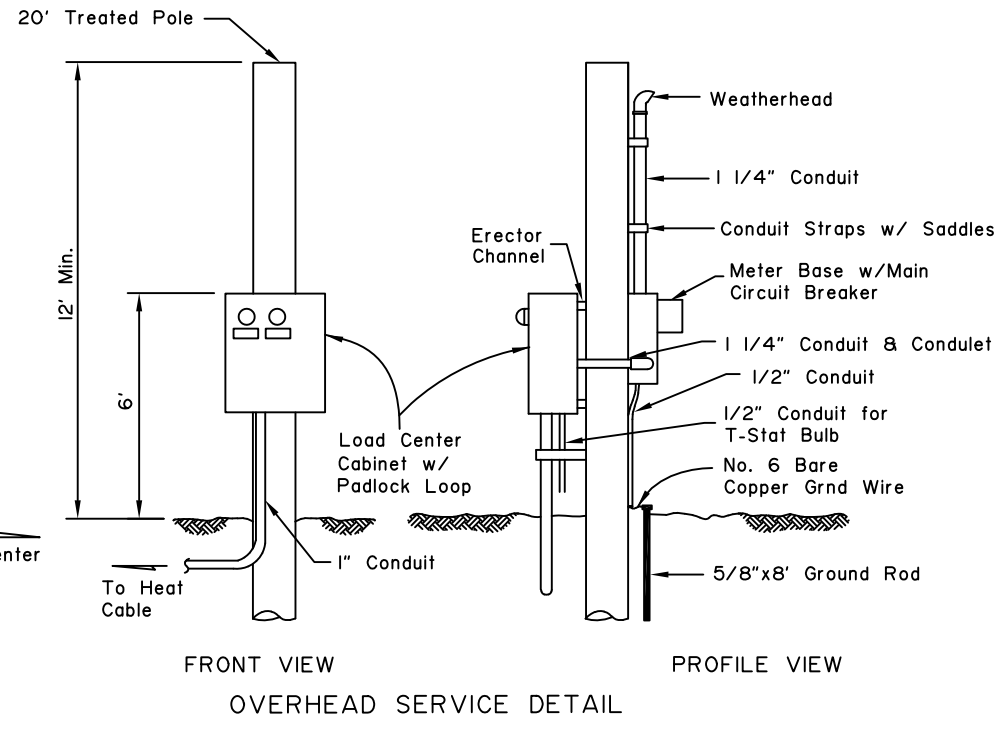
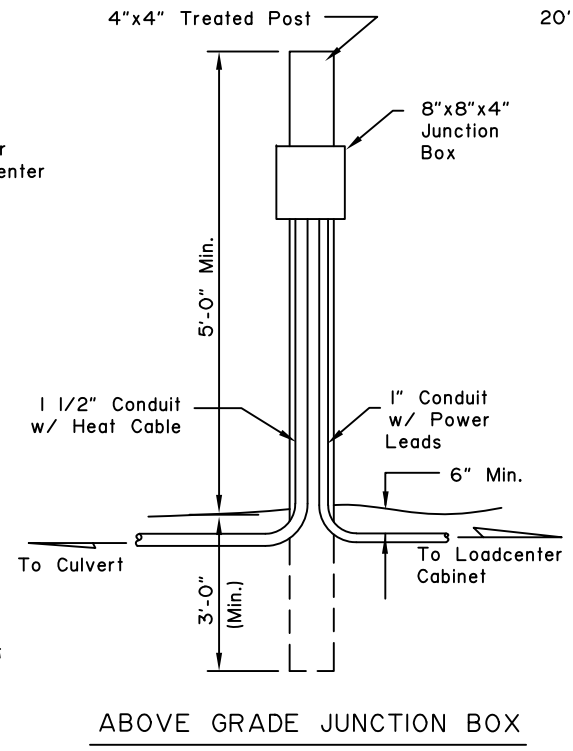
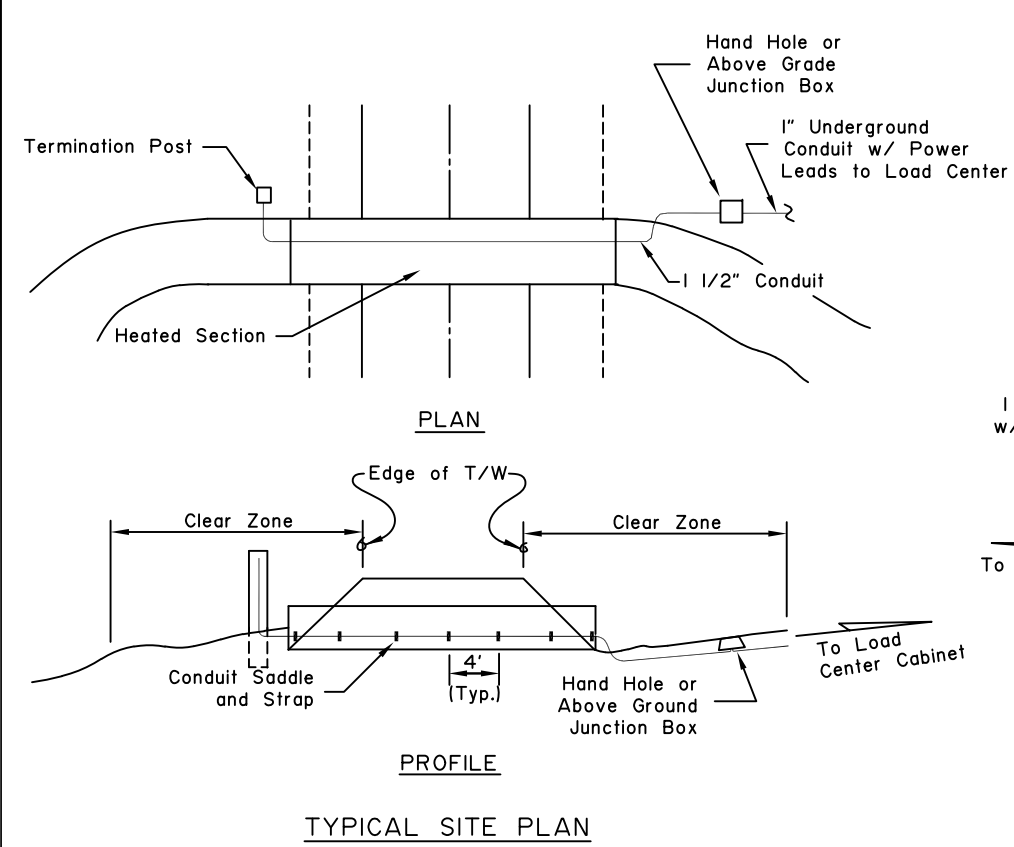

State of Alaska DOT&PF
 ALASKA STANDARD PLAN
CULVERT THAW WIRE INSTALLATION
 Adopted as an Alaska Standard Plan by: *Kenneth J. Fisher*
 Kenneth J. Fisher, P.E.
 Chief Engineer
 Adoption Date: 02/08/2019
 Last Code and Stds. Review By: Date:
 Next Code and Standards Review date: 02/08/2029

GENERAL NOTES:

1. Loadcenter Cabinet panel face shall be placed parallel with the highway.
2. Type FD Cast Device Box w/green pilot light on the termination post shall be located a minimum of 6" above high water.

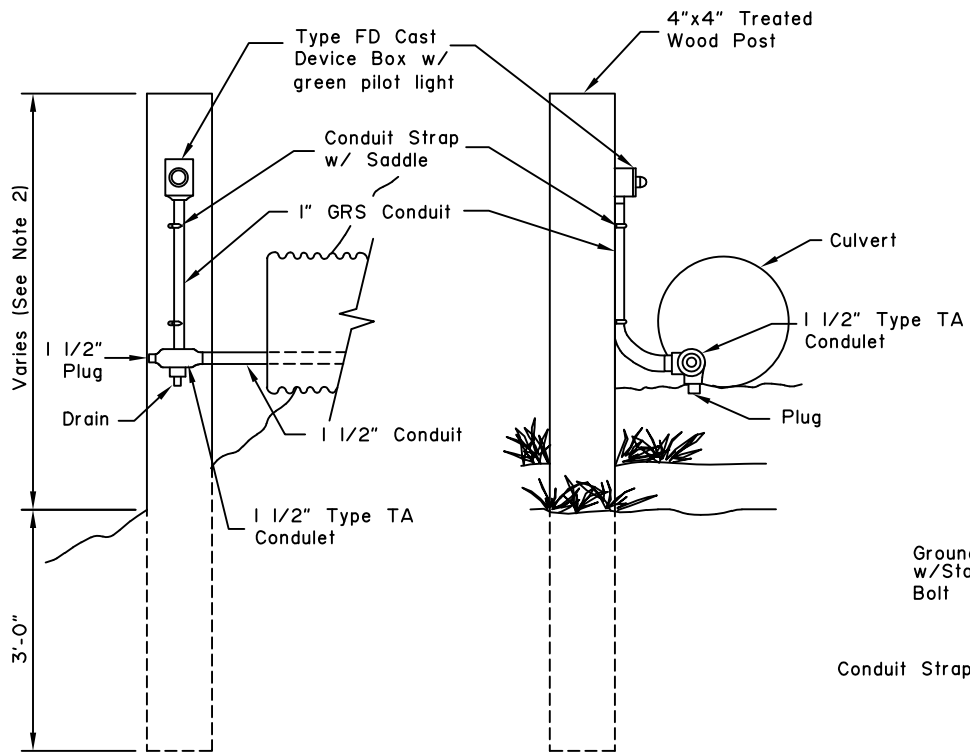

FRONT VIEW PROFILE VIEW
TERMINATION POST DETAIL

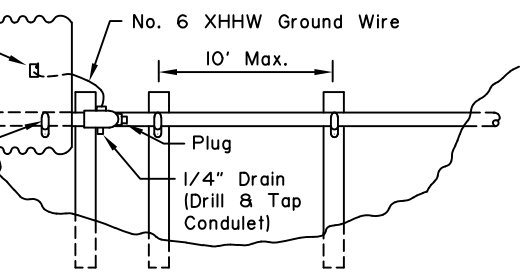
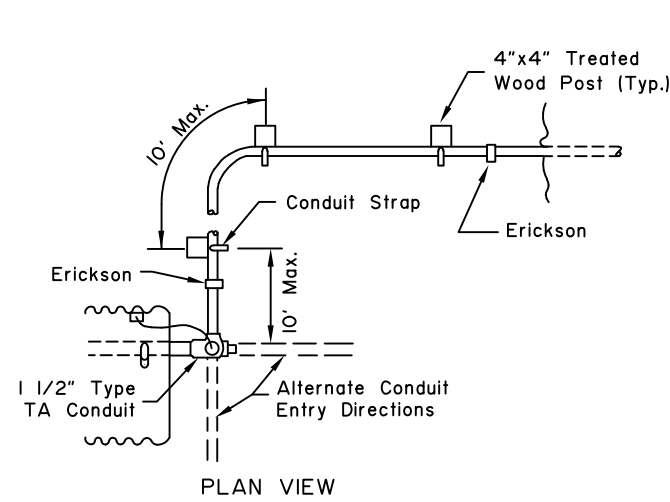

PLAN VIEW
ELEVATION
CULVERT ENTRY DETAIL

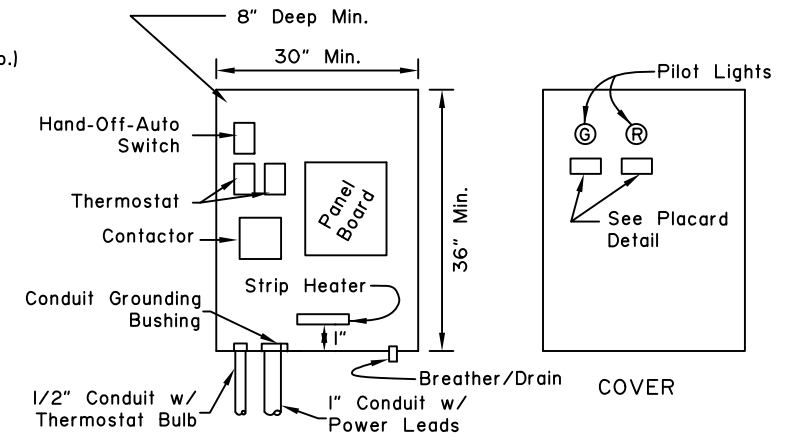

LOAD CENTER CABINET
(NEMA 4 Cabinet w/ Drip Shield)

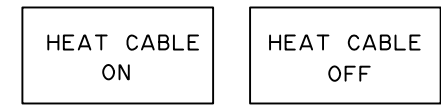

PLACARD DETAIL

SIZE	MAX. LENGTH
15/2	175 Ft.
20/2	240 Ft.
30/2	320 Ft.
40/2	415 Ft.

CIRCUIT BREAKER SIZING TABLE

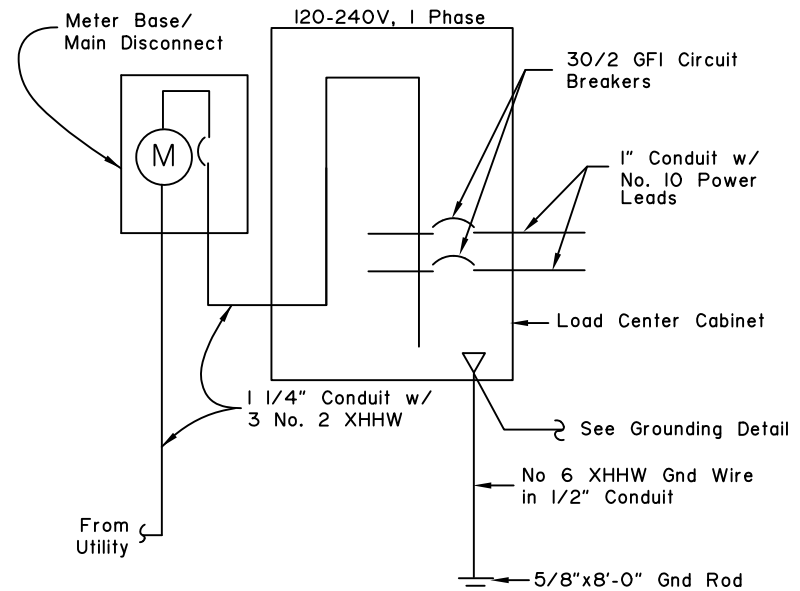

SINGLE LINE DIAGRAM

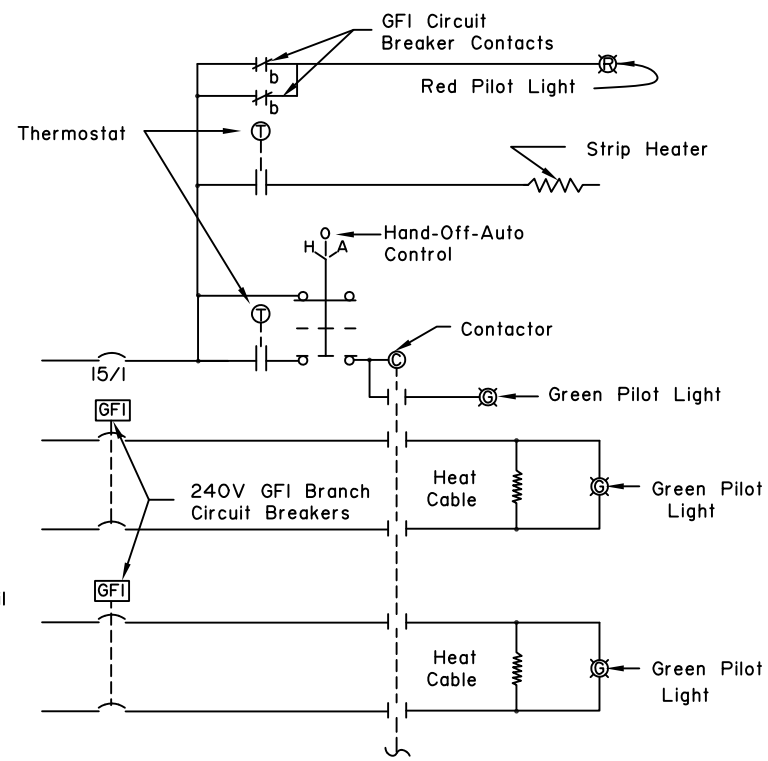

CONTROLS DIAGRAM

NOTE: May use same scheme for other quantities of Heat Cable Circuits.

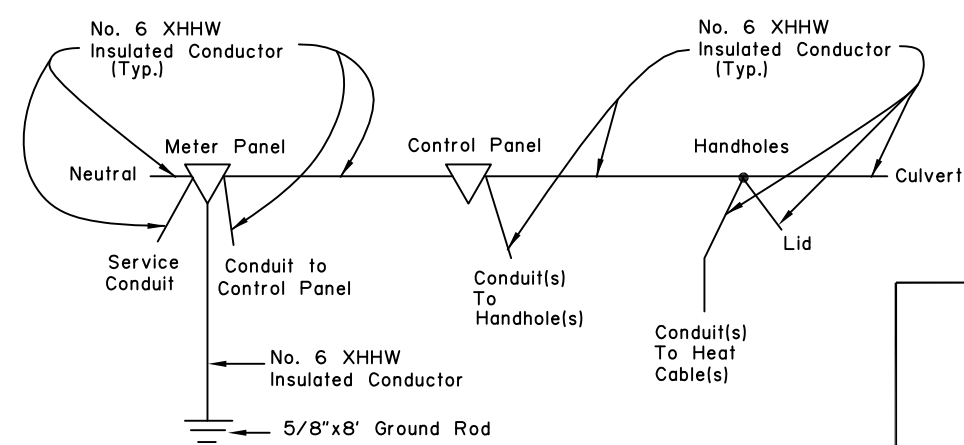

GROUNDING DETAIL

State of Alaska DOT&PF
ALASKA STANDARD PLAN
CULVERT THAW
WIRE INSTALLATION

Adopted as an Alaska Standard Plan by: *Kenneth J. Fisher*
Kenneth J. Fisher, P.E.
Chief Engineer

Adoption Date: 02/08/2019

Last Code and Stds. Review By: Date:

Next Code and Standards Review date: 02/08/2029

GENERAL NOTES:

- 1. Type FD Cast Device Box w/green pilot light shall be located a minimum of 6" above high water.

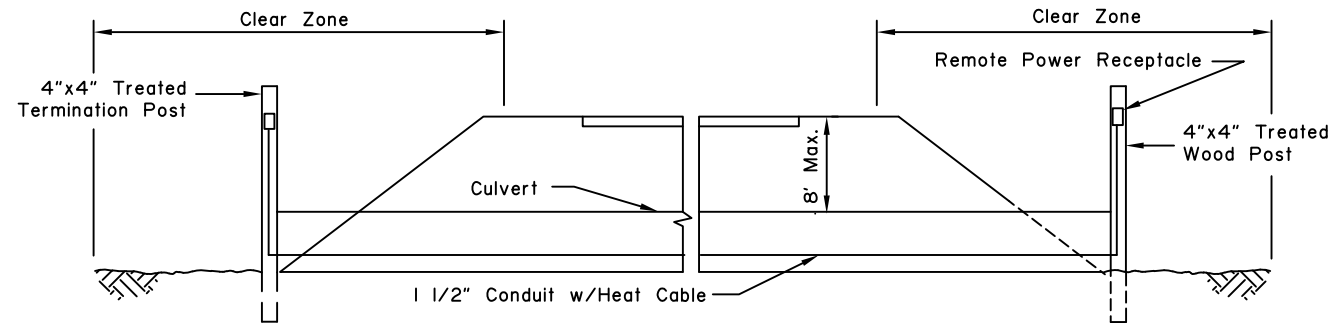

SECTION THRU CULVERT
(Low Fill)

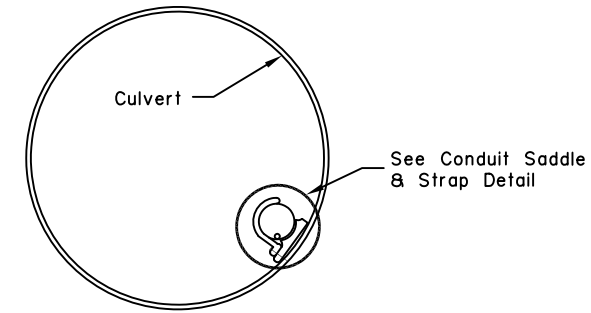

CULVERT CROSS SECTION

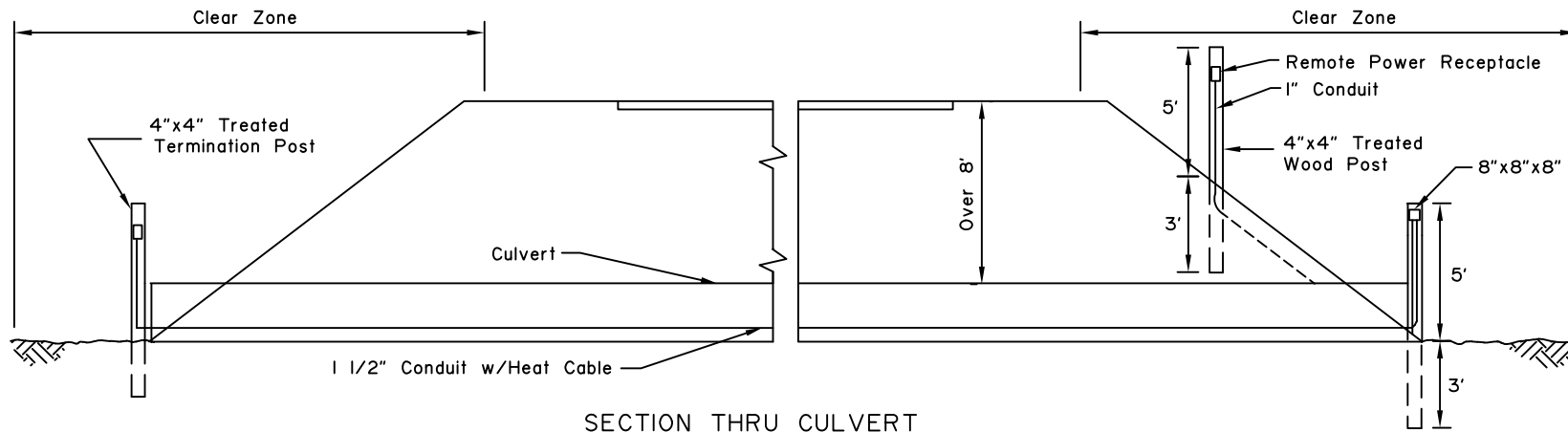

SECTION THRU CULVERT
(High Fill)

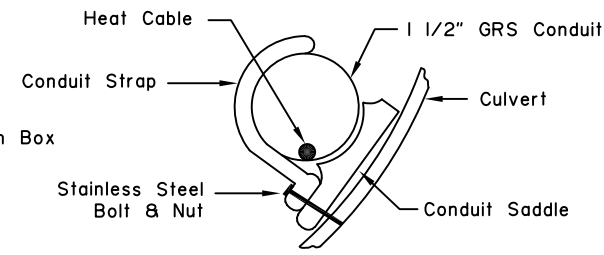

CONDUIT SADDLE &
STRAP DETAIL

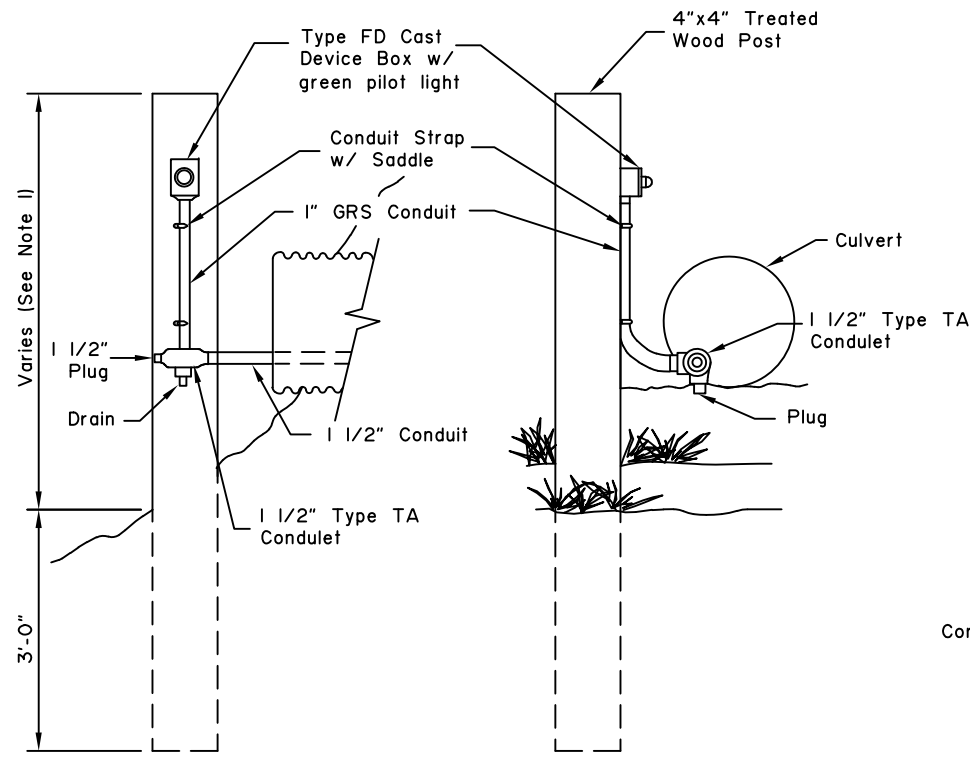

FRONT VIEW PROFILE VIEW
TERMINATION POST DETAIL

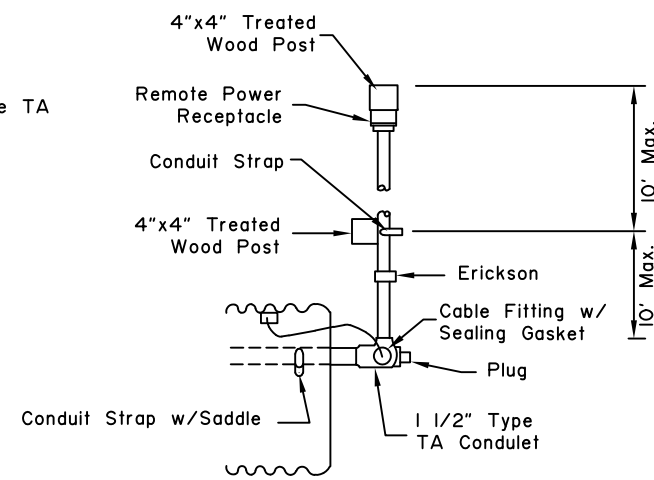

PLAN VIEW

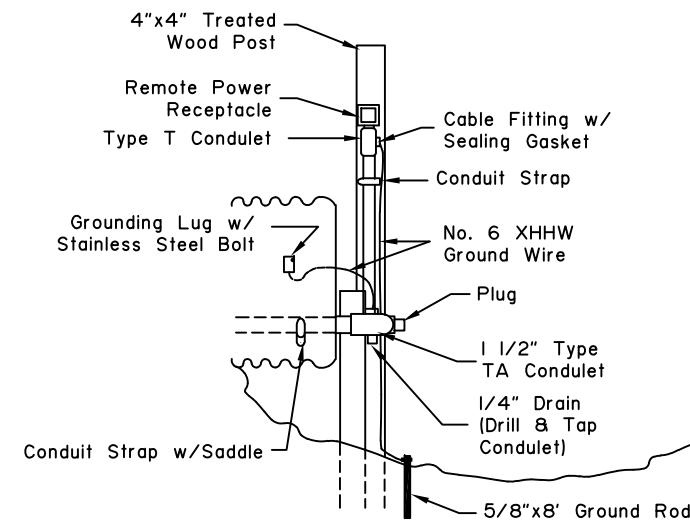

ELEVATION

REMOTE CULVERT ENTRY DETAIL

State of Alaska DOT&PF
ALASKA STANDARD PLAN
REMOTE THAW WIRE
INSTALLATION

Adopted as an Alaska
Standard Plan by: *Kenneth J. Fisher*
Kenneth J. Fisher, P.E.
Chief Engineer

Adoption Date: 02/08/2019

Last Code and Stds. Review
By: Date:

Next Code and Standards Review date: 02/08/2029

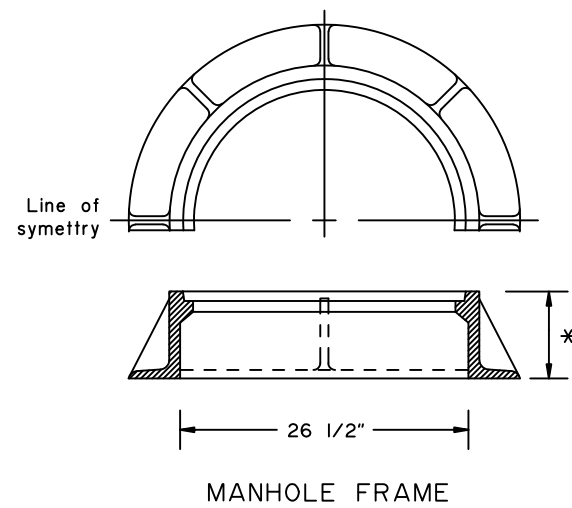
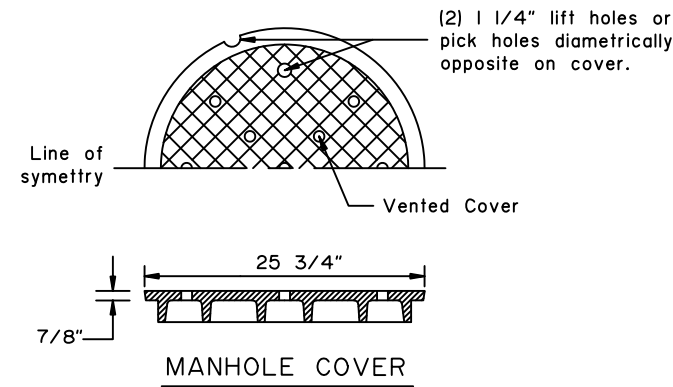
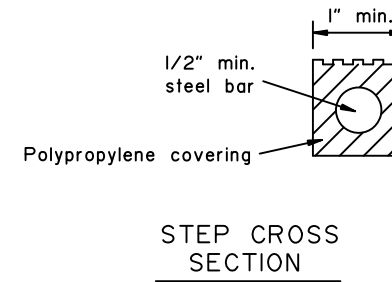
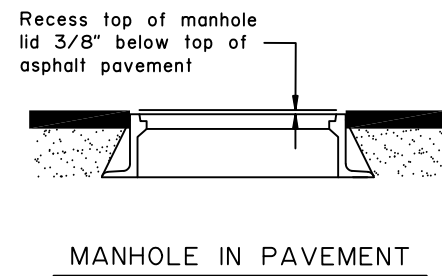
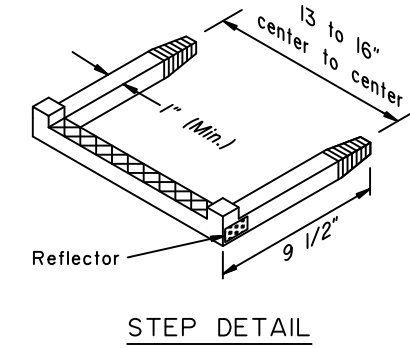
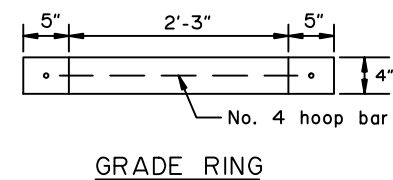
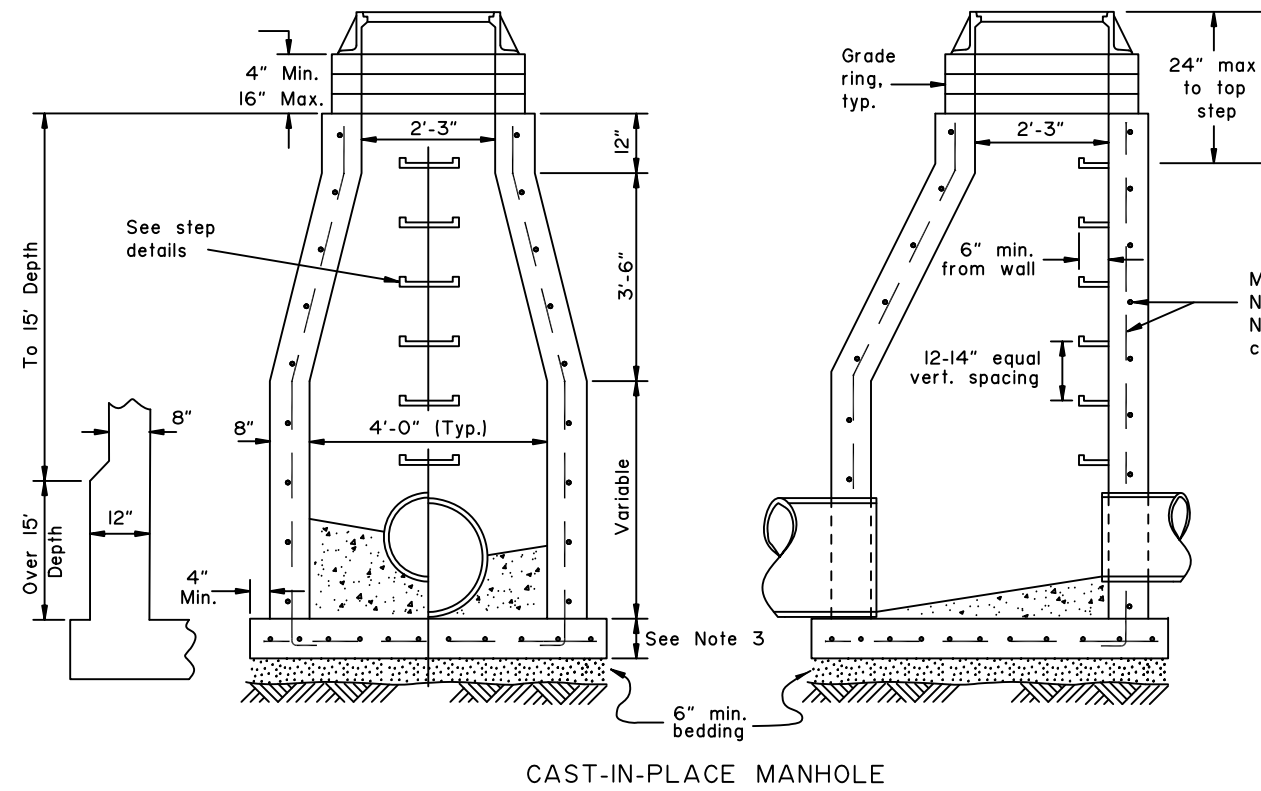

* Depth	Weight
6"	380 lbs
7"	400 lbs
8"	440 lbs
9"	470 lbs
10"	500 lbs

- GENERAL NOTES:**
1. Either precast or cast-in-place manholes may be used.
 2. Details for manhole frame, cover and step are generic in nature and may vary from shown depending on manufacturer
 3. Use 8" thick cast-in-place concrete bases for depths less than 15' and 12" thick bases for depths 15' or greater.
 4. Manhole frames shall have a depth of 6" unless otherwise indicated on the plans.
 5. Step requirements:
 - a. 18" max. vertical clearance to bottom of manhole or concrete invert.
 - b. 3" minimum embedment.
 - c. 1,500 lb. min. pullout force.
 - d. ASTM A-615 grade 60 steel bar.
 - e. Injection molded polypropylene covering meeting ASTM D-41010
 - f. Slip resistant foot tread with "wings" to prevent feet from sliding off the edge.
 - g. Reflectors at step corners
 6. Reinforcement for precast manhole sections shall meet AASHTO M 199.

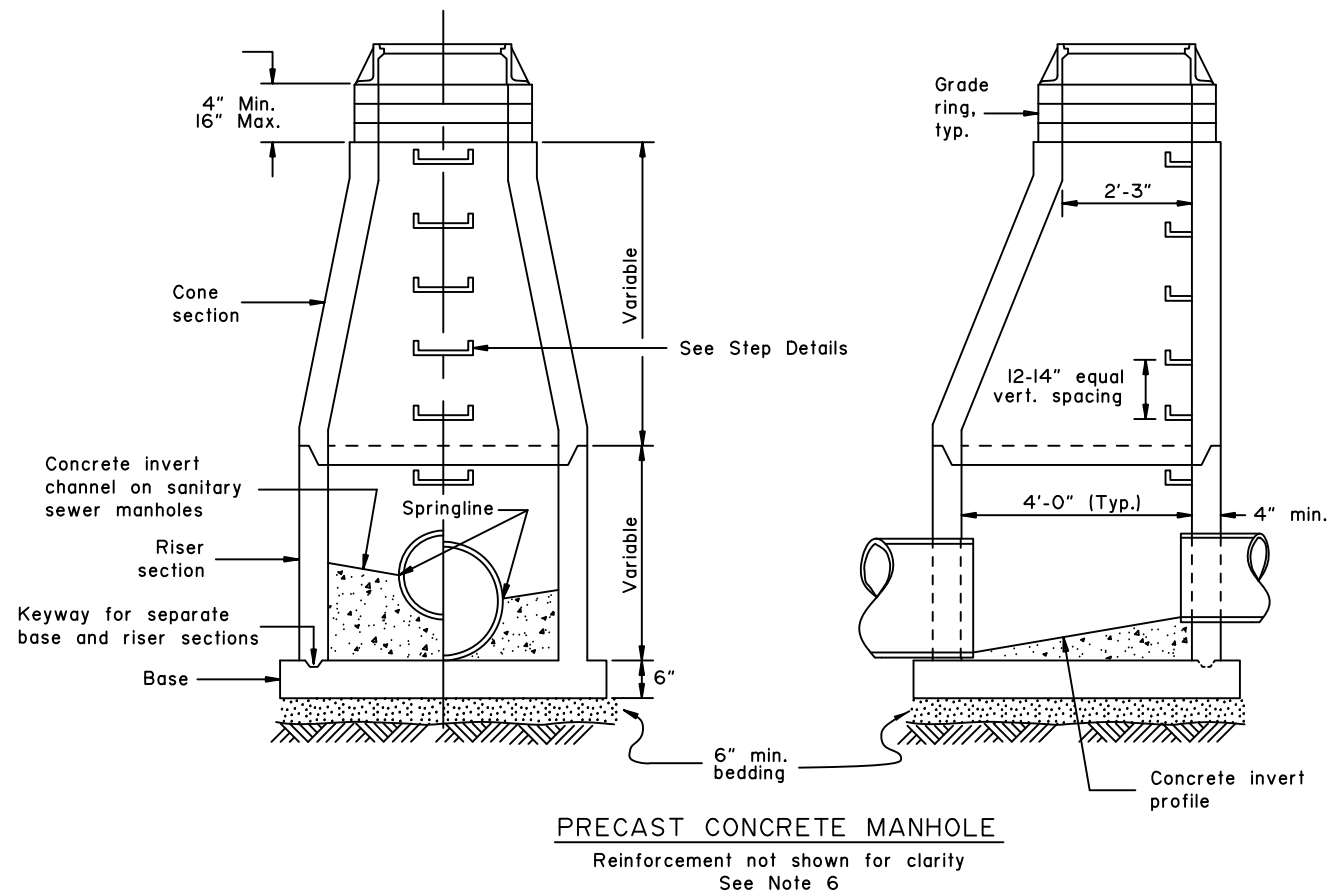

State of Alaska DOT&PF
ALASKA STANDARD PLAN
MANHOLES, FRAME AND COVER

Adopted as an Alaska Standard Plan by: *Kenneth J. Fisher*
Kenneth J. Fisher, P.E.
Chief Engineer

Adoption Date: 02/08/2019

Last Code and Stds. Review By: Date:

Next Code and Standards Review date: 02/08/2029

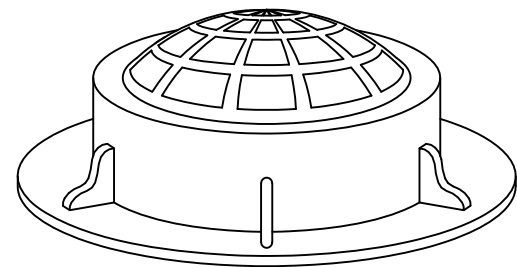

Surround field inlets with a 24" wide rock rubble collar 10" deep, 3" maximum size rock.

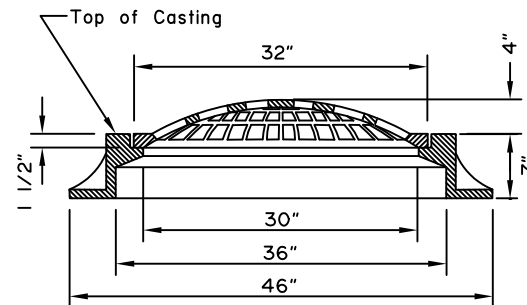

FIELD INLET FRAME & GRATE

To be supplied for storm drain manholes where field inlets are specified. Field inlet frame and grate shall have a Minimum total weight of 525 lb.

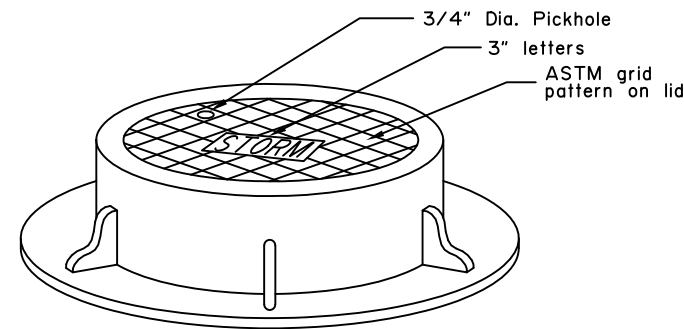

MANHOLE LID FRAME AND GRATE

NOTES:

- Details shown are to indicate general design only. Dimensions and design may vary among the manufacturers, except that inlet grate shall be within $\frac{1}{4}$ "± of dimensions shown on this drawing.
- Manhole lids shall be 32" in diameter and may be used with field inlet frames.
- Type A field inlet frame inside dimensions shall be 24" x 36". Lugs will not protrude outside the concrete surface of the inlet box.
- Grates shall be bicycle safe. Where high capacity grates are called for on the plans, they shall conform to Std. Dwg. D-25.
- Frame and grate casting types are identified by the following abbreviations:
C.I. = Curb Inlet
F.I. = Field Inlet
M.H. = Manhole
- Flowline depression shall conform to Std. Dwg. D-23 for an on grade or sag point conditions.
- These are the default frames and grates to be used unless shown otherwise on the drainage plans or drainage structure summary.

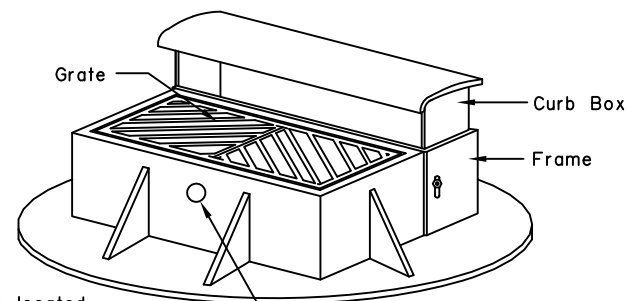

Pickhole located 3" from the top of frame

NOTE: Curb Box, Grate and frame shall have a minimum total weight of 725 lb.

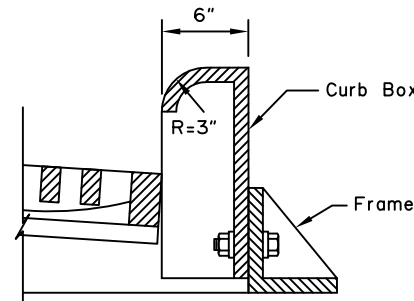

SIDE VIEW
MOUNTABLE CURB AND GUTTER

REQUIRED FRAME AND GRATES (See Note 7)			
STRUCTURE	INLET TYPE	CURB TYPE	TYPE FRAME AND GRATE
INLET BOX, TYPE A	Curb	Mountable	Standard Curb Inlet
	Curb	Expressway	Mountable Curb Inlet
	Curb	Rolled Curb	Depressed Inlet
	Field	-----	Field Inlet
STORM DRAIN MANHOLES, TYPE I, II AND III	Curb	Mountable	Mountable Curb Inlet
	Curb	Expressway	Expressway Curb Inlet
	Curb	Rolled Curb	Depressed Inlet
	Field	-----	Field Inlet
	Manhole Lids	-----	Field Inlet Frame, Solid MH. Lid

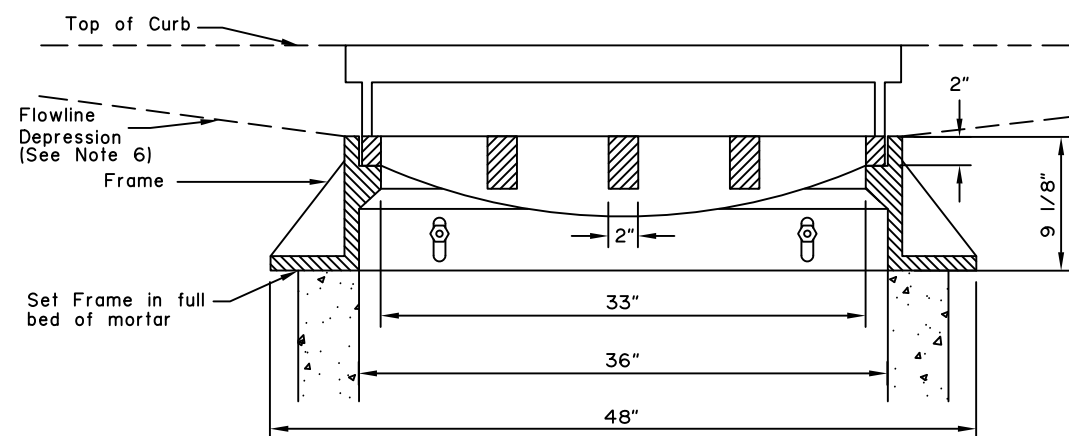

FRONT VIEW

CURB INLET FRAME AND GRATE

To be supplied for storm drain manholes Type I, Type II and Type III where curb inlets are specified.

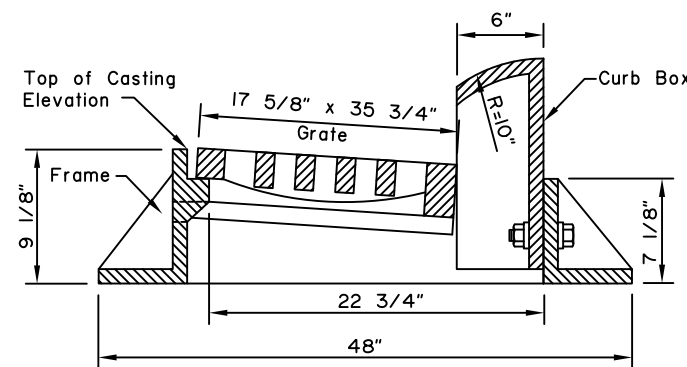

SIDE VIEW
EXPRESSWAY CURB AND GUTTER

NOT TO SCALE

State of Alaska DOT&PF
ALASKA STANDARD PLAN
STORMDRAIN MANHOLE
FRAME AND GRATE
DETAILS

Adopted as an Alaska Standard Plan by: *Kenneth J. Fisher*
Kenneth J. Fisher, P.E.
Chief Engineer

Adoption Date: 02/08/2019

Last Code and Stds. Review By: Date:
Next Code and Standards Review date: 02/08/2029

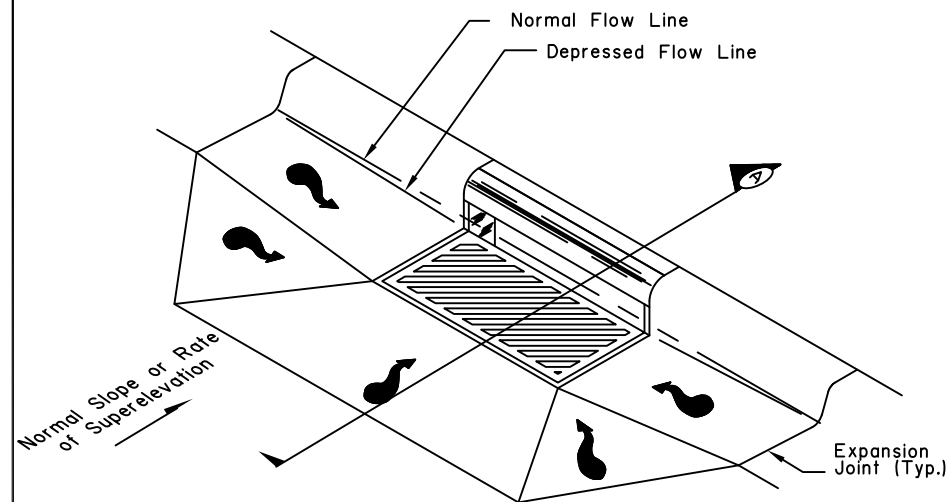

STANDARD CURB INLET INSTALLATION

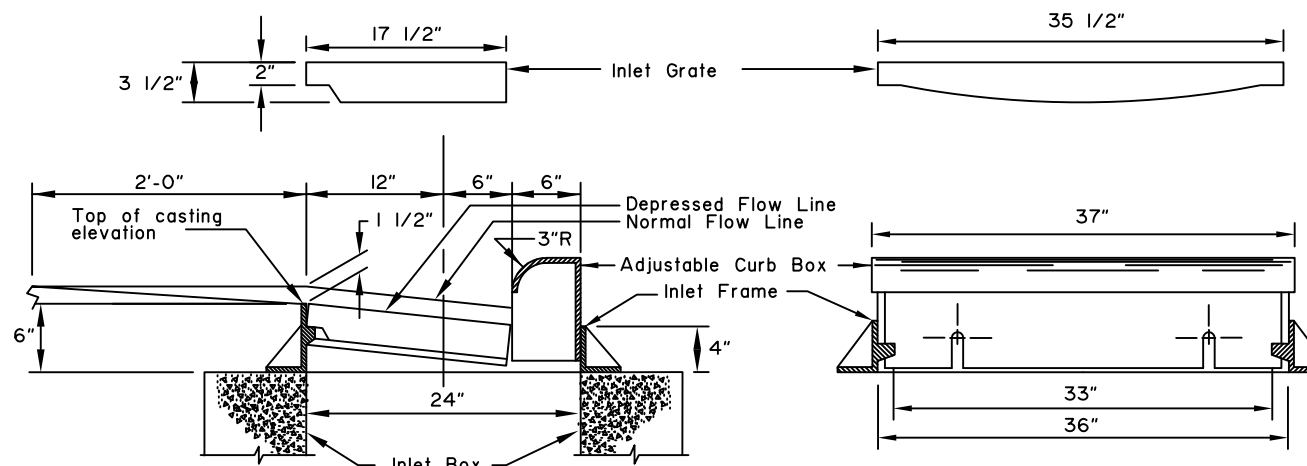

SECTION A

- GENERAL NOTES:**
1. Details shown are to indicate general design only. Dimensions and design may vary among the manufacturers.
 2. Minimum casting weight shall be 330 lbs for Curb Inlet Frame with Curb Box and 200 lbs. for Inlet Grate.
 3. The outside dimensions of Inlet Grate shall be 35 1/2" x 17 1/2" and all grates shall be interchangeable.
 4. Minimum drainage area of Inlet Grate shall be 255 square inches.
 5. Inlet Grate type G-3R or G-3L shall be used in all cases except where drainage is from both directions, in which case type G-4 shall be used.

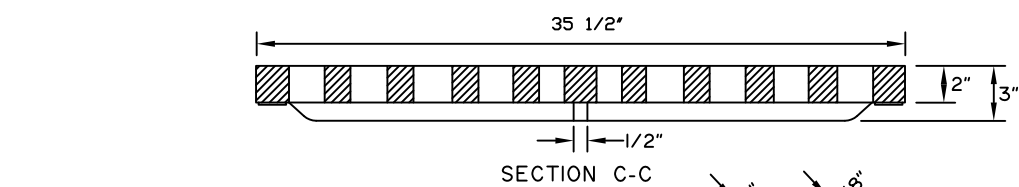

SECTION C-C

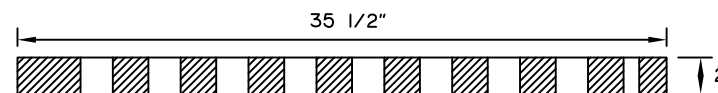

SECTION B-B

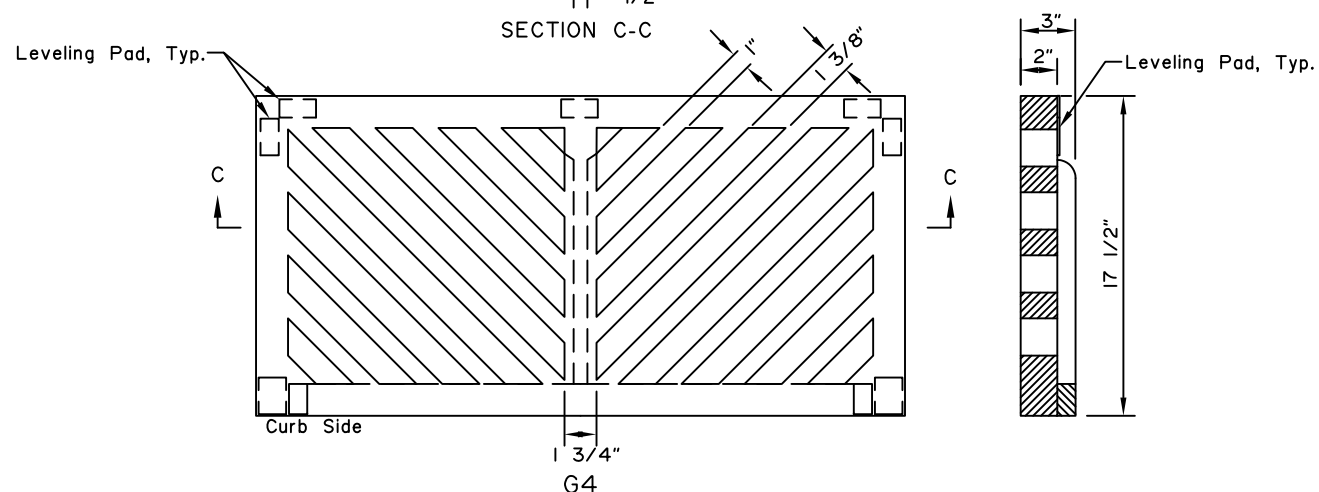

G4

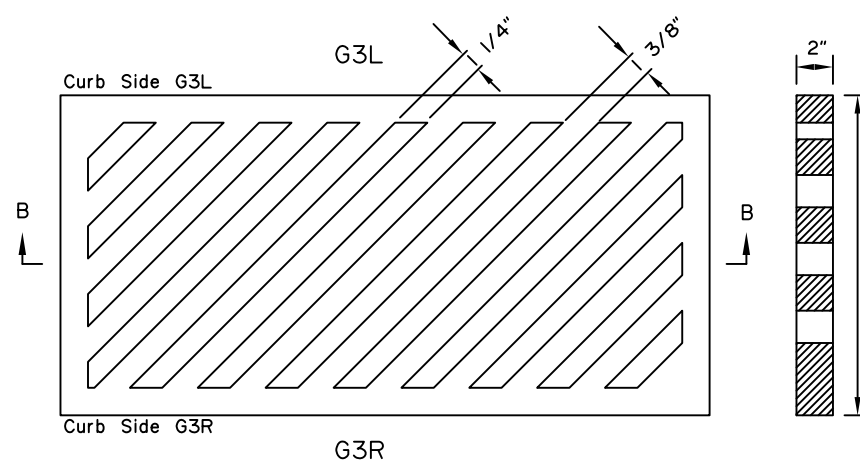

G3R

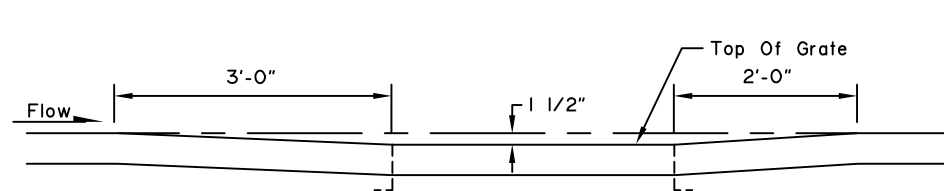

ON GRADE

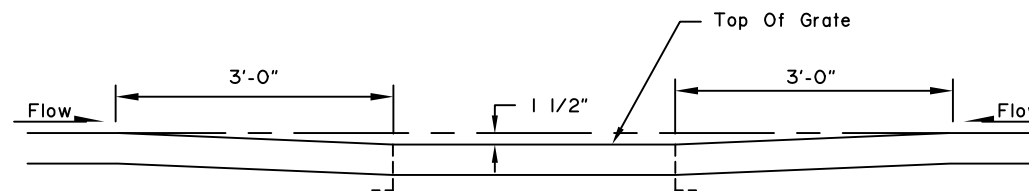

AT LOW POINT

DEPRESSION IN FLOW LINE AT INLET CONSTRUCTION DETAILS

State of Alaska DOT&PF
ALASKA STANDARD PLAN

**CURB INLET BOX,
FRAME & GRATE**

Adopted as an Alaska
Standard Plan by: *Kenneth J. Fisher*
Kenneth J. Fisher, P.E.
Chief Engineer

Adoption Date: 02/08/2019

Last Code and Stds. Review
By: Date:

Next Code and Standards Review date: 02/08/2029

NOT TO SCALE

GENERAL NOTES:

1. Details shown are to indicate general design only. Dimensions and design may vary among the manufacturers. Except inlet grate outside dimension shall be as shown on this drawing.
2. Minimum casting weight shall be 550lbs. for Curb Inlet Frame and Grate, 450lbs. for Gutter Inlet Frame and Grate, and 300lbs. for Field Inlet Frame and Grate.
3. Field Inlet Frame may be welded assembly of L 1 3/4"x1 3/4"x1/4" angle equivalent to ASTM A-36 steel.

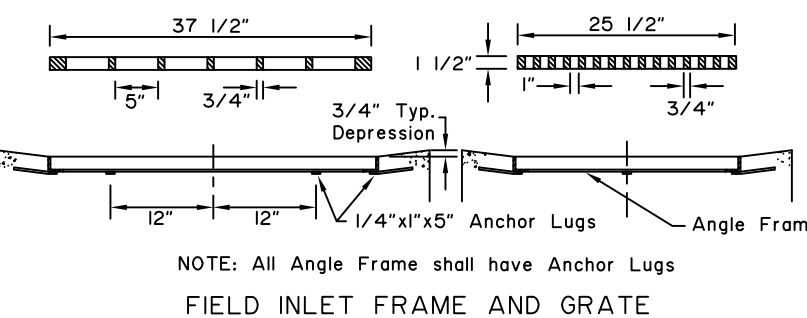
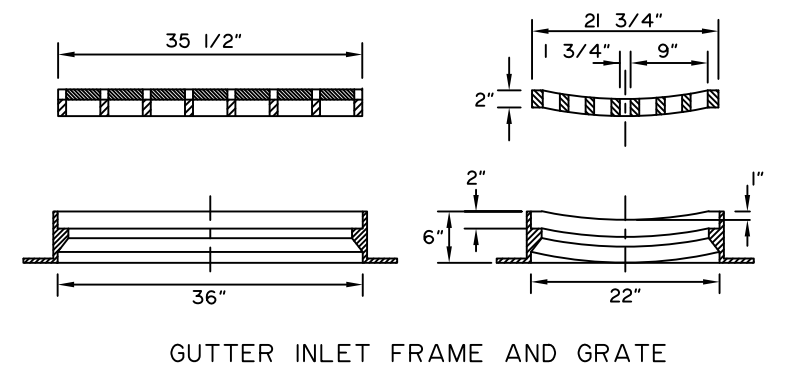
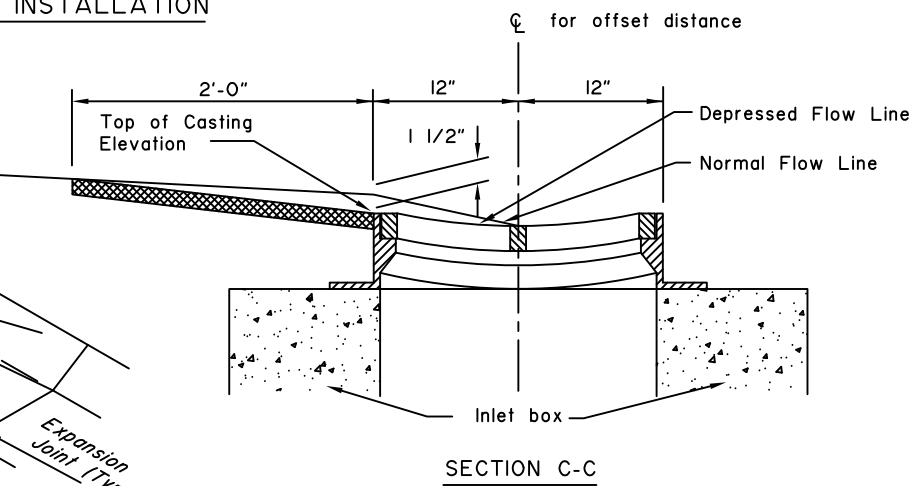
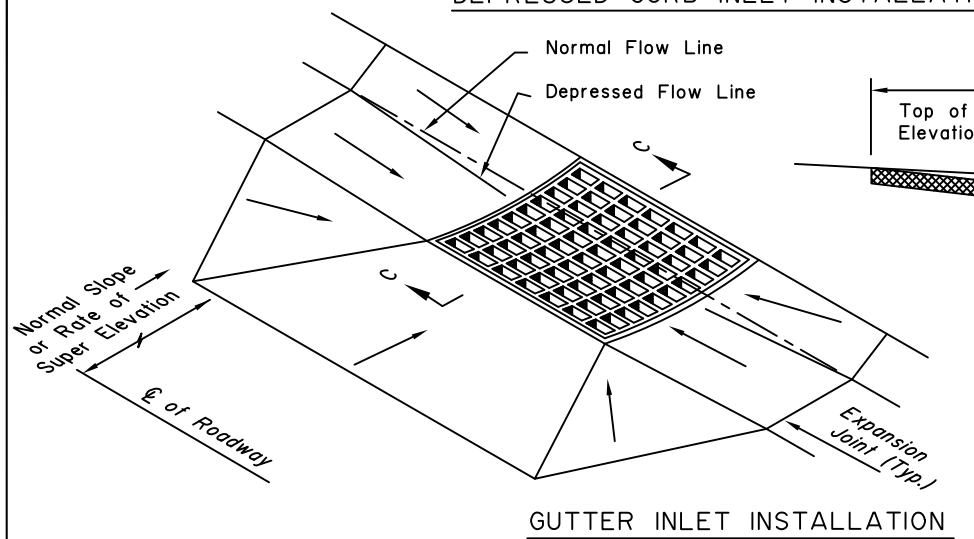
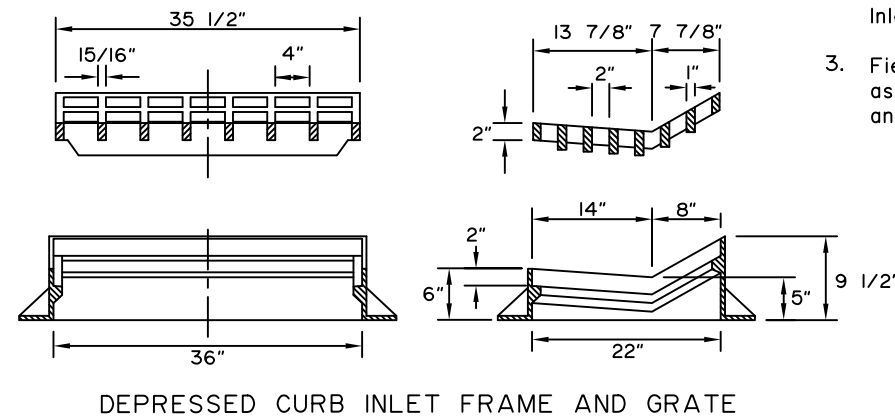
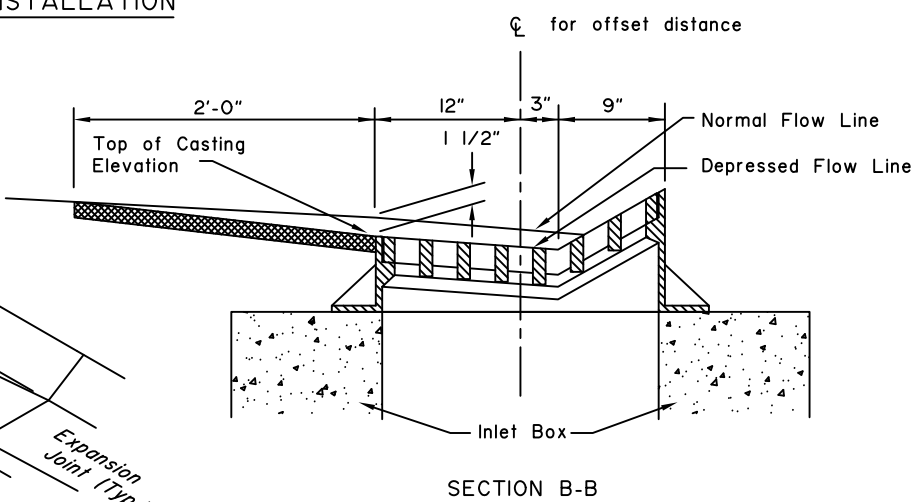
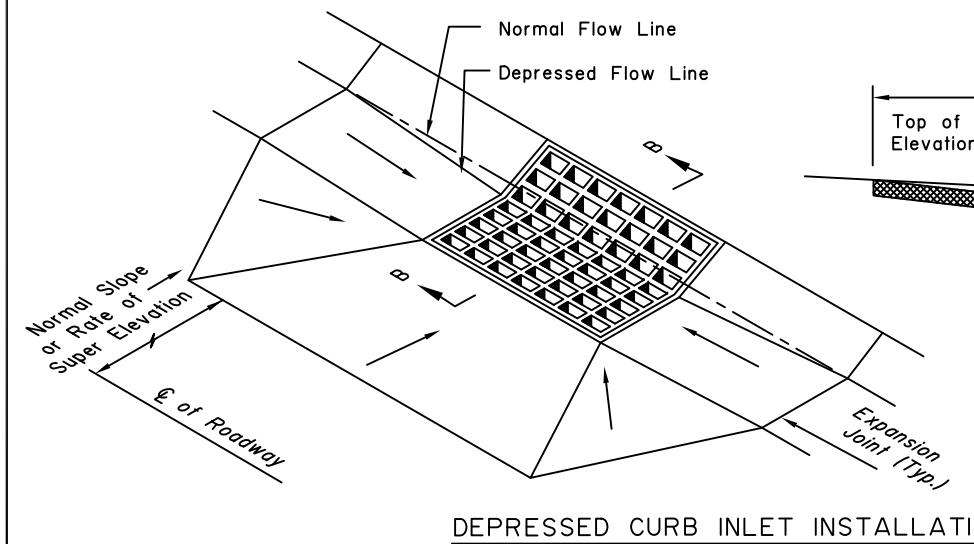
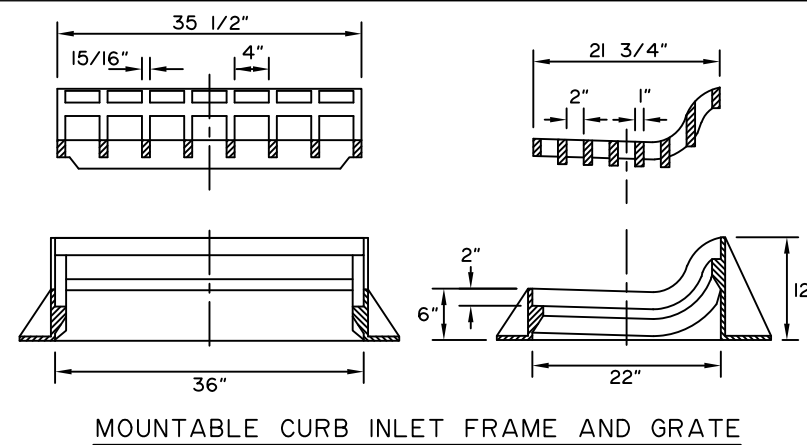
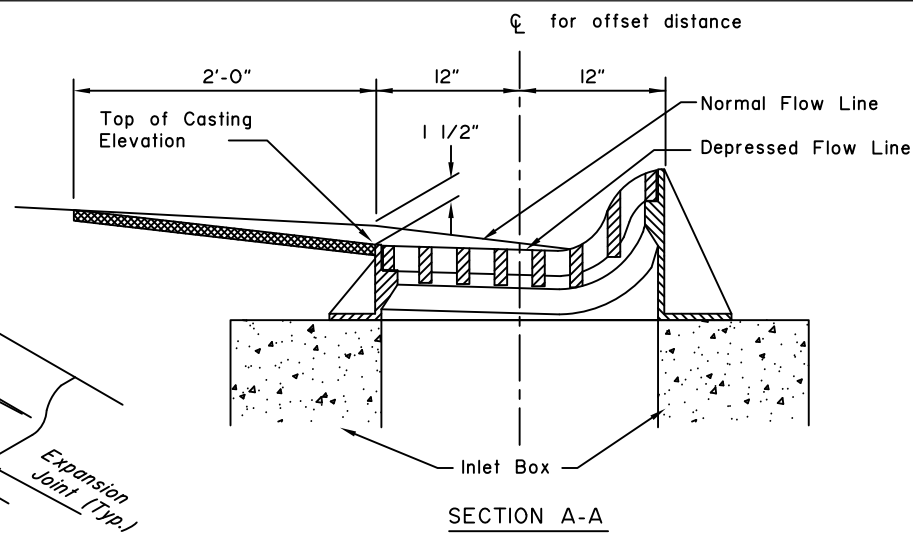
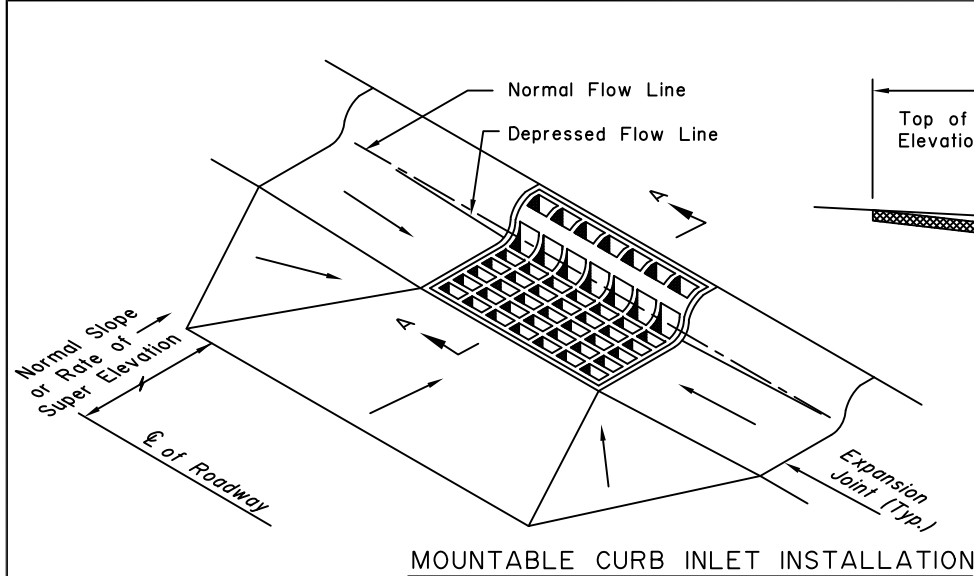

NOTE: All Angle Frame shall have Anchor Lugs

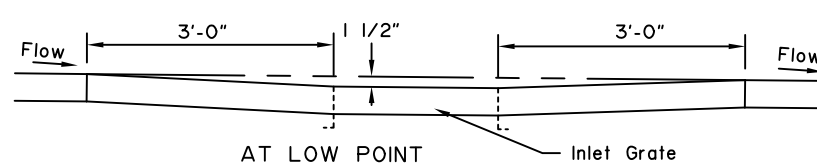
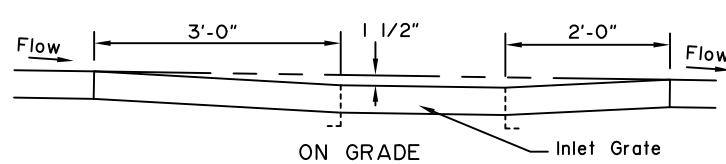

DEPRESSION IN FLOW LINE AT INLET CONSTRUCTION DETAILS

State of Alaska DOT&PF
ALASKA STANDARD PLAN
**INLET FRAMES
AND GRATES**

Adopted as an Alaska Standard Plan by: *Kenneth J. Fisher*
Kenneth J. Fisher, P.E.
Chief Engineer

Adoption Date: 02/08/2019

Last Code and Stds. Review By: Date:

Next Code and Standards Review date: 02/08/2029

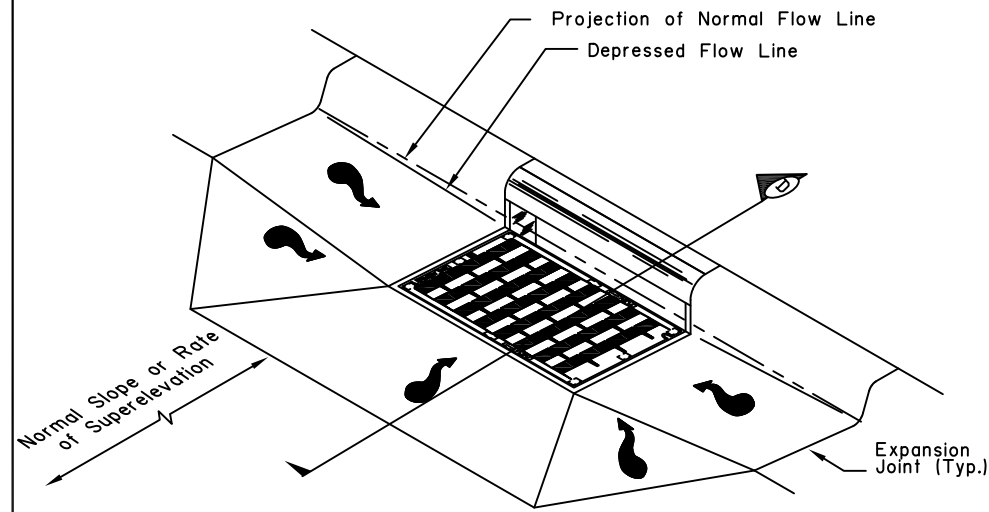

STANDARD CURB INLET INSTALLATION

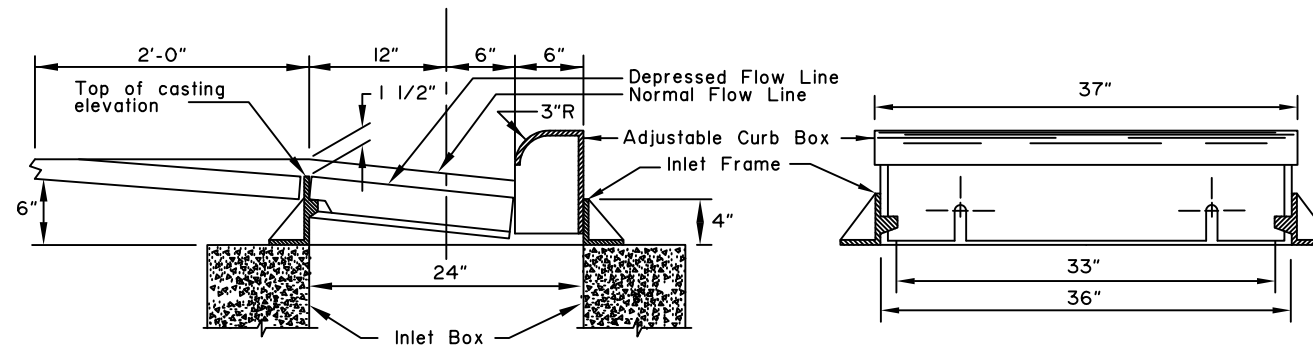

SECTION (D)

NOTES:

1. Details shown are to indicate general design only. Dimensions and design may vary among the manufacturers.
2. Minimum casting weight shall be 330 lbs for Curb Inlet Frame with Curb Box and 150 lbs. for Inlet Grate.
3. The outside dimensions of Inlet Grate shall be 35 1/2" x 17 1/2" and all grates shall be interchangeable.

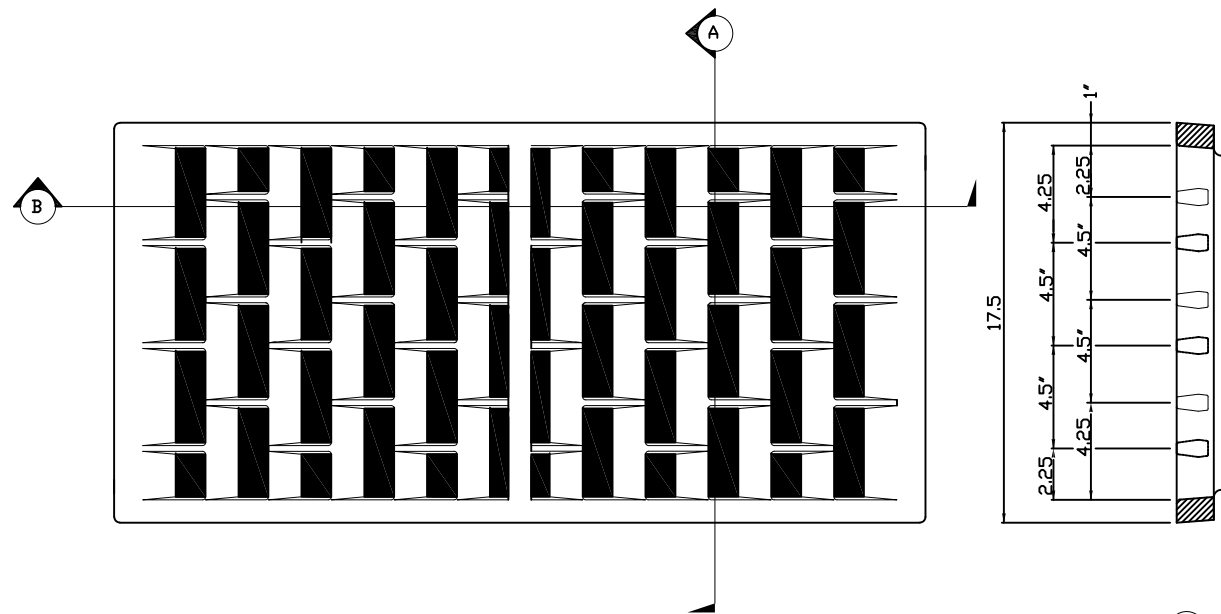

PLAN VIEW

SECTION (A)

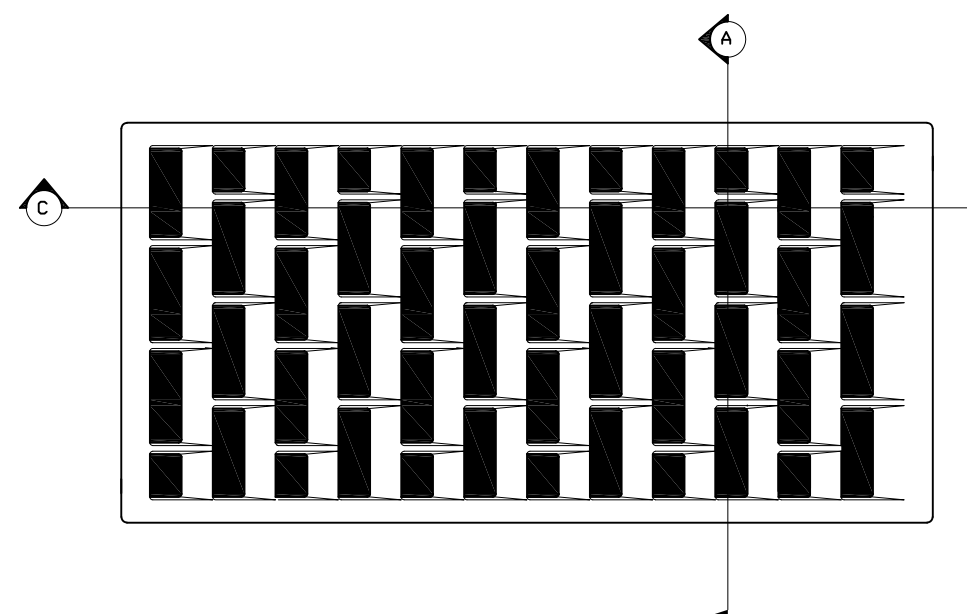

PLAN VIEW

SECTION (C)

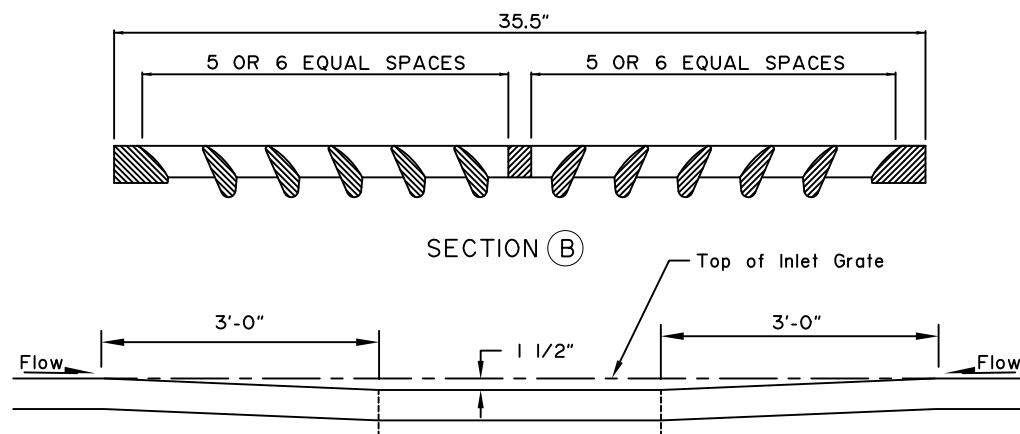

SECTION (B)

AT SAG POINT

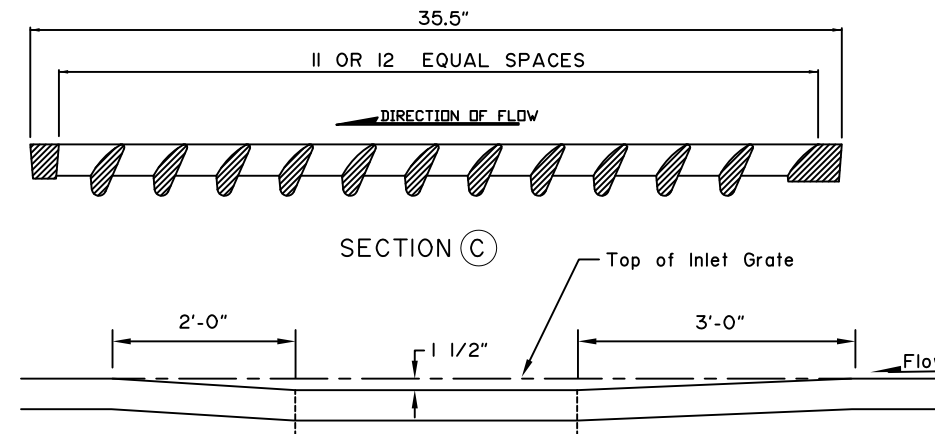

SECTION (C)

ON GRADE

DEPRESSION IN FLOW LINE AT INLET CONSTRUCTION DETAILS

NOT TO SCALE

State of Alaska DOT&PF
ALASKA STANDARD PLAN

HIGH CAPACITY
CURB INLET BOX
FRAME AND GRATE

Adopted as an Alaska
Standard Plan by: *Kenneth J. Fisher*
Kenneth J. Fisher, P.E.
Chief Engineer

Adoption Date: 02/08/2019

Last Code and Stds. Review
By: Date:

Next Code and Standards Review date: 02/08/2029

NOTES:

- Details shown are to indicate general design only. Dimensions may vary between manufacturers. Tolerance for grate dimension shall be +/- 1", unless otherwise noted.

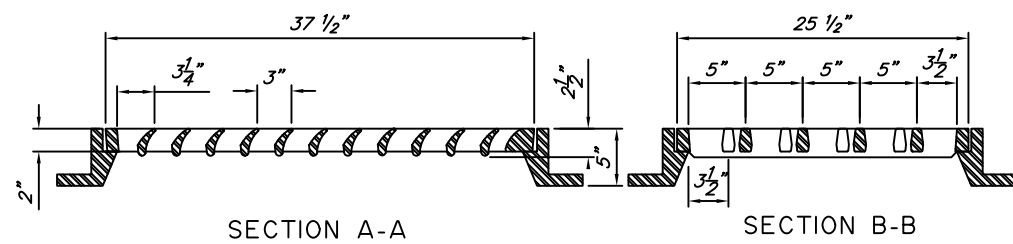
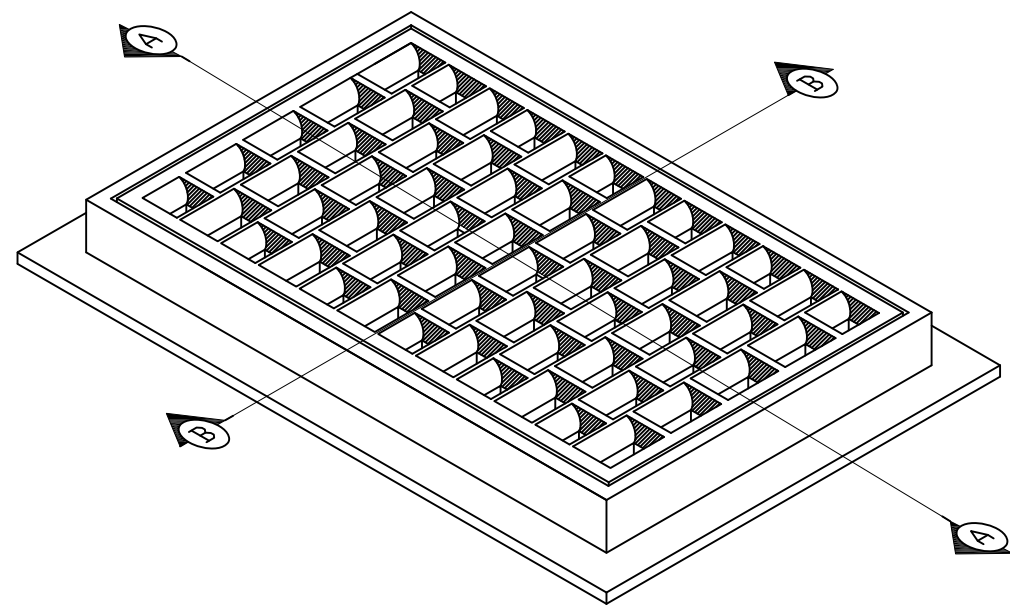

SECTION A-A SECTION B-B

HIGH CAPACITY FIELD INLET FRAME AND GRATE

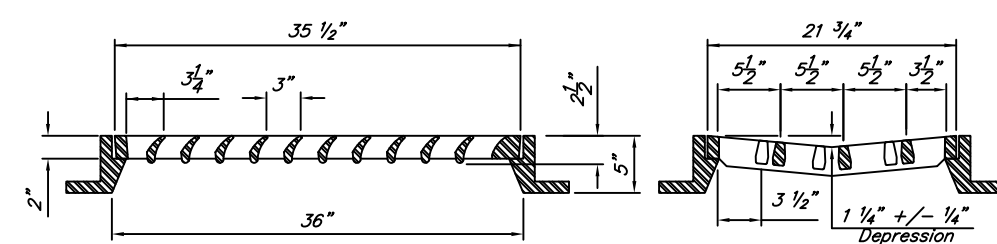
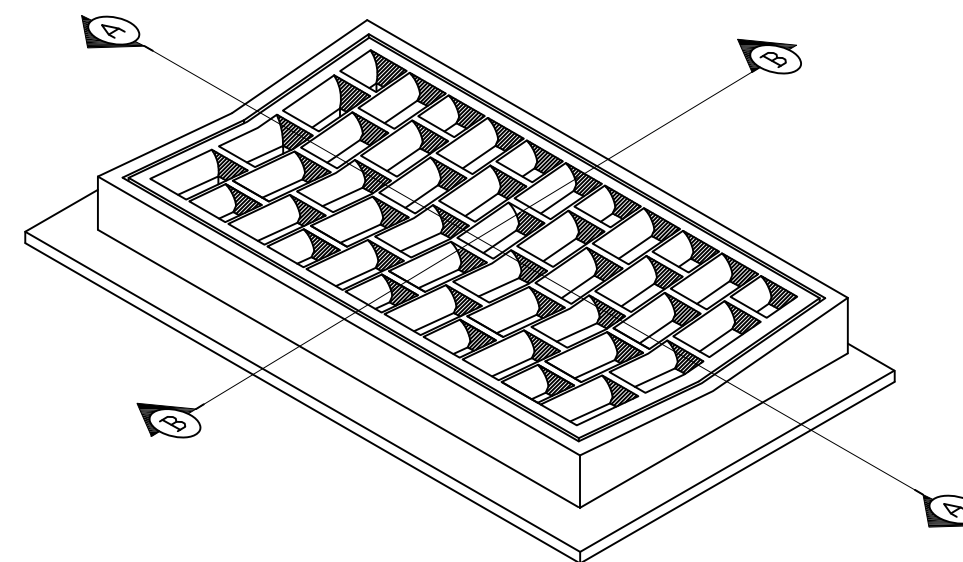

SECTION A-A SECTION B-B

HIGH CAPACITY GUTTER INLET FRAME AND GRATE

State of Alaska DOT&PF
ALASKA STANDARD PLAN
**HIGH CAPACITY CURB INLET
BOX FRAME AND GRATE
(FIELD AND GUTTER INLETS)**

Adopted as an Alaska
Standard Plan by: *Kenneth J. Fisher*
Kenneth J. Fisher, P.E.
Chief Engineer

Adoption Date: 02/08/2019

Last Code and Stds. Review
By: Date:

Next Code and Standards Review date: 02/08/2029

NOT TO SCALE

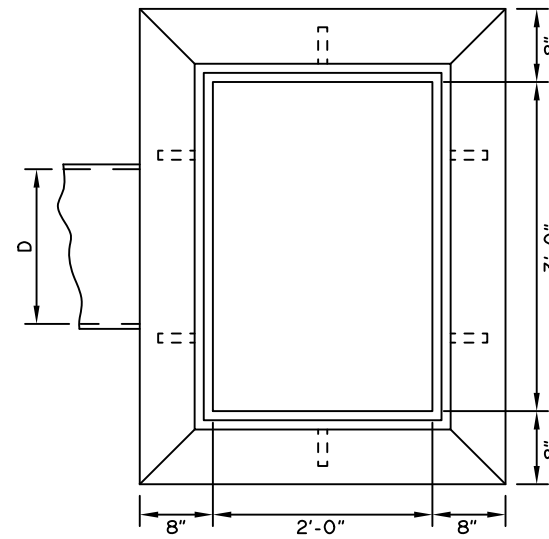
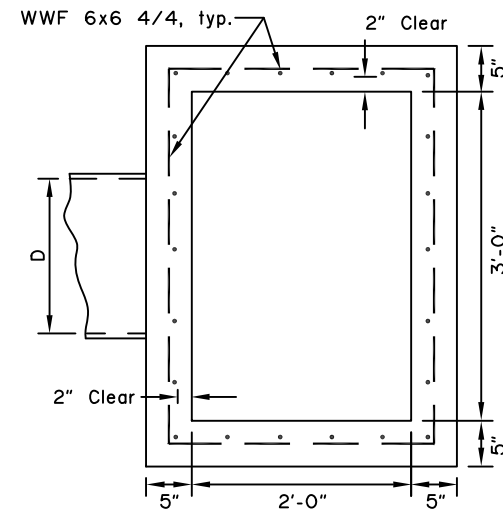
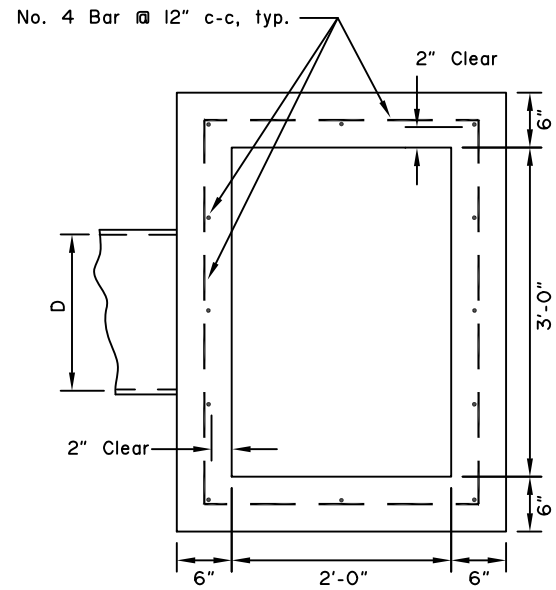

GENERAL NOTES:

1. Install inlet boxes parallel to the curb line.
2. The plans will indicate which inlet boxes require a sump.
3. Shape floors to drain.
4. Use Grade 40 minimum reinforcing steel.
5. The plans will indicate which inlet boxes require sumps.

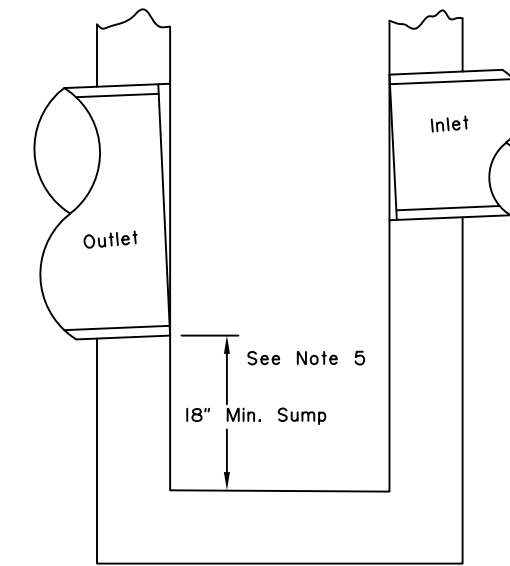
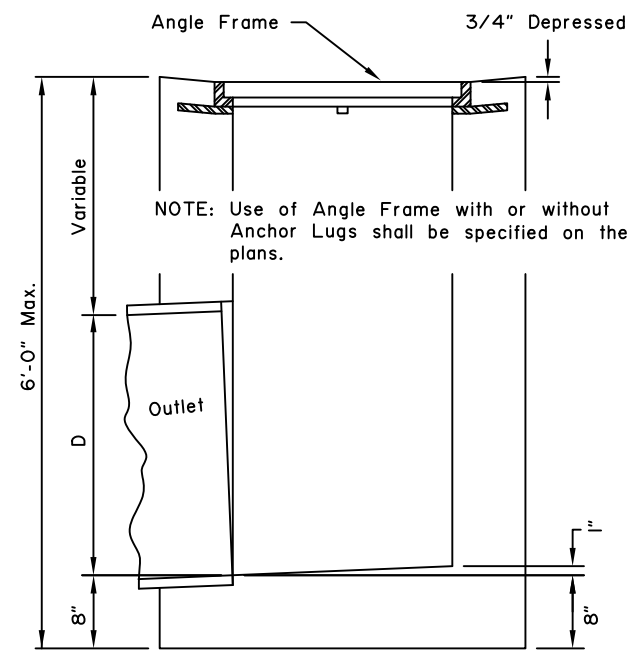
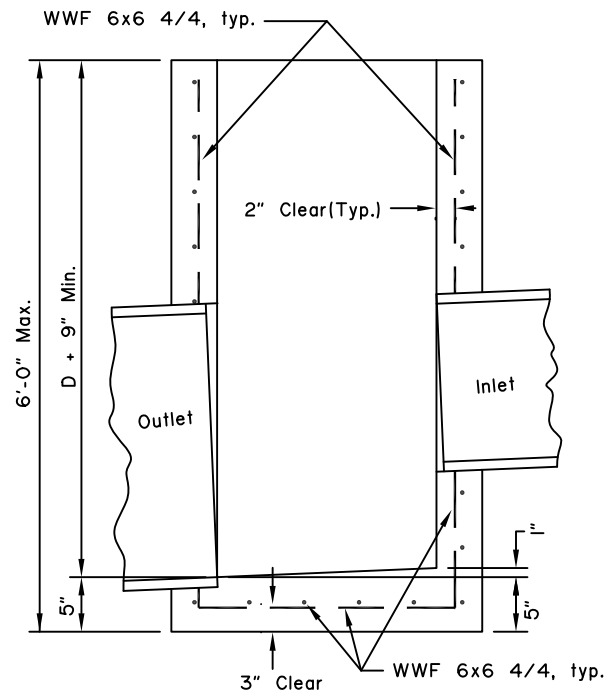
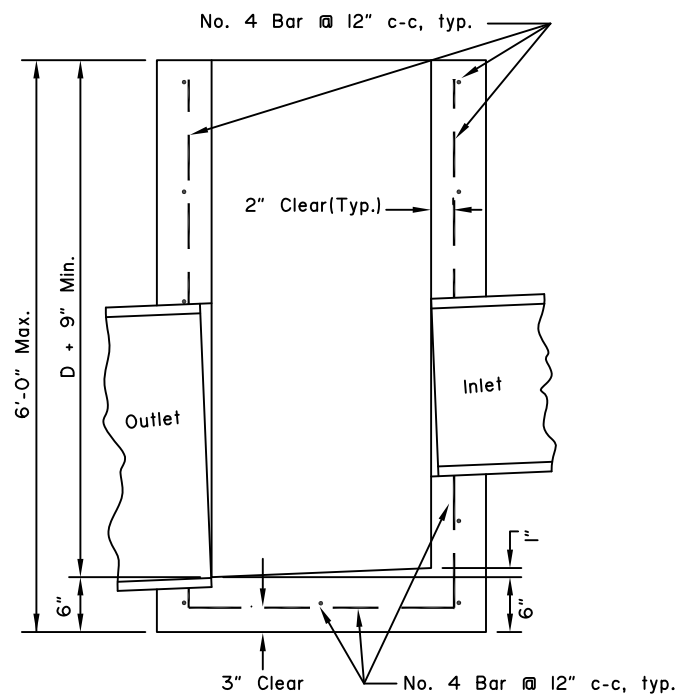

SUMP DETAIL

REINFORCED
CAST IN PLACE

PRECAST

FIELD INLET BOX
CAST* IN PLACE

TYPE "A" CONCRETE INLET BOXES

* May be Precast or Reinforced Cast-In-Place Box.

State of Alaska DOT&PF
ALASKA STANDARD PLAN

TYPE "A"
INLET BOX

Adopted as an Alaska Standard Plan by: *Kenneth J. Fisher*
Kenneth J. Fisher, P.E.
Chief Engineer

Adoption Date: 02/08/2019

Last Code and Stds. Review
By: Date:

Next Code and Standards Review date: 02/08/2029

NOT TO SCALE

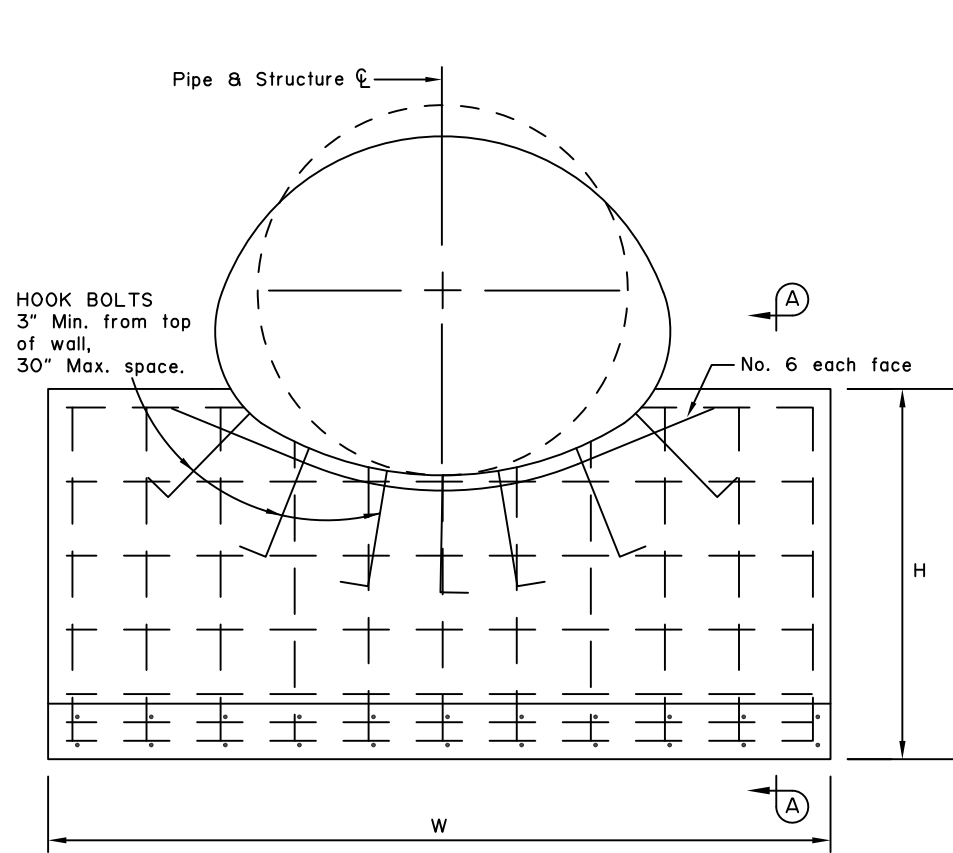

ELEVATION

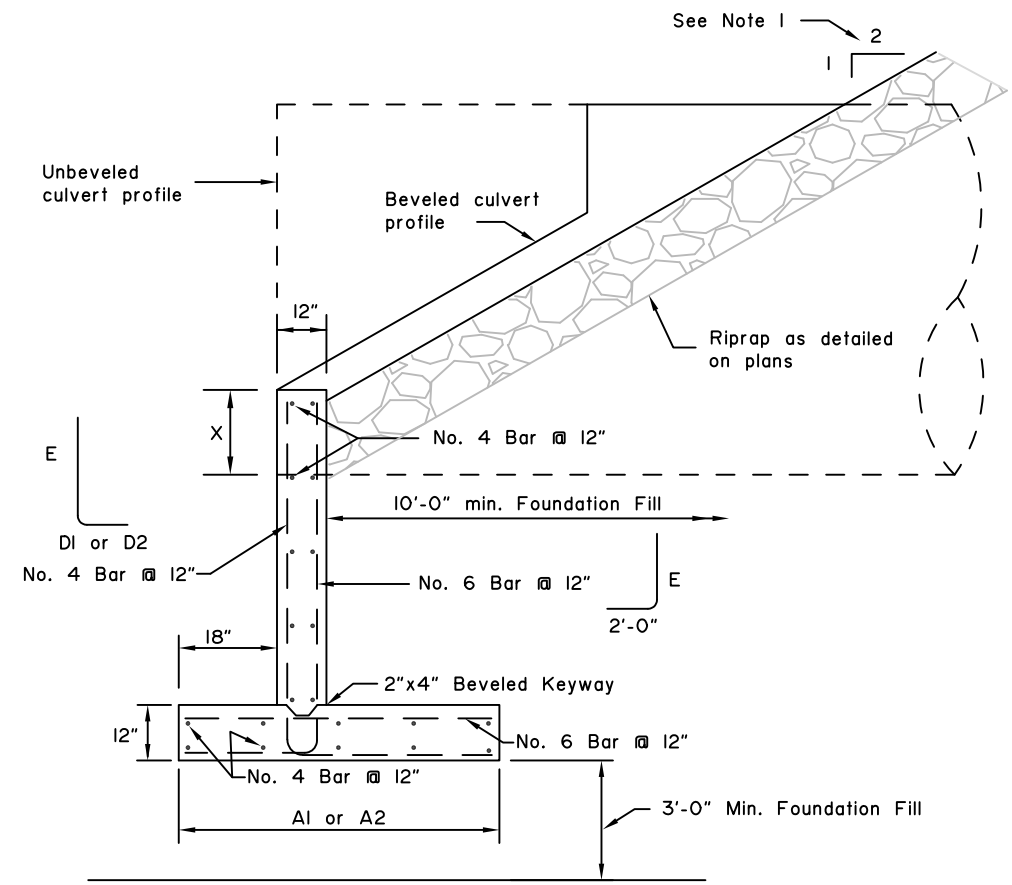

SECTION A-A

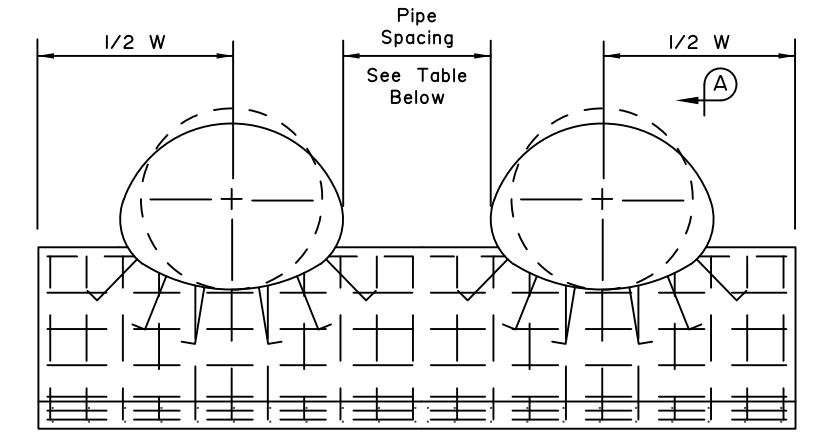

MULTIPLE INSTALLATION

Minimum Space Between Pipes	
1/2 Dia. of Pipe or 1/2 Span of Pipe Arch, 24" Min.	

CORRUGATED METAL PIPE * SEE NOTE II							
Dia.	W	H	A1*	A2*	D1*	D2*	E
5'-0"	9'-0"	4'-0"	4'-0"	4'-0"	2'-0"	2'-0"	3'-6"
5'-6"	10'-0"	4'-6"	4'-0"	4'-0"	2'-0"	2'-0"	4'-0"
6'-0"	11'-0"	4'-6"	4'-0"	4'-0"	2'-0"	2'-0"	4'-0"
6'-6"	12'-0"	4'-6"	4'-0"	4'-0"	2'-0"	2'-0"	4'-0"
7'-0"	12'-6"	4'-6"	4'-0"	4'-0"	2'-0"	2'-0"	4'-0"
7'-6"	13'-6"	5'-0"	4'-6"	4'-0"	2'-6"	2'-0"	4'-6"
8'-0"	14'-6"	5'-0"	4'-6"	4'-0"	2'-6"	2'-0"	4'-6"
8'-6"	15'-6"	5'-0"	4'-6"	4'-0"	2'-6"	2'-0"	4'-6"
9'-0"	16'-6"	5'-6"	5'-0"	4'-0"	3'-0"	2'-0"	5'-0"
9'-6"	17'-0"	5'-6"	5'-0"	4'-0"	3'-0"	2'-0"	5'-0"
10'-0"	18'-0"	5'-6"	5'-0"	4'-0"	3'-0"	2'-0"	5'-0"
10'-6"	19'-0"	5'-6"	5'-0"	4'-0"	3'-0"	2'-0"	5'-0"
11'-0"	20'-0"	5'-6"	5'-0"	4'-0"	3'-0"	2'-0"	5'-0"
11'-6"	21'-0"	5'-6"	5'-0"	4'-0"	3'-0"	2'-0"	5'-0"
12'-0"	21'-6"	5'-6"	5'-0"	4'-0"	3'-0"	2'-0"	5'-0"
12'-6"	22'-6"	5'-6"	5'-0"	4'-0"	3'-0"	2'-0"	5'-0"
13'-0"	23'-6"	5'-6"	5'-0"	4'-0"	3'-0"	2'-0"	5'-0"
13'-6"	24'-6"	6'-0"	5'-6"	4'-0"	3'-6"	2'-0"	5'-6"
14'-0"	25'-6"	6'-6"	6'-0"	4'-0"	4'-0"	2'-0"	6'-0"
14'-6"	26'-0"	6'-6"	6'-0"	4'-0"	4'-0"	2'-0"	6'-0"
15'-0"	27'-0"	6'-6"	6'-0"	4'-0"	4'-0"	2'-0"	6'-0"

CORRUGATED METAL PIPE ARCH * SEE NOTE II									
SPAN	RISE	W	H	A1*	A2*	D1*	D2*	E	
6'-1"	4'-7"	14'-0"	5'-0"	4'-6"	4'-0"	2'-6"	2'-0"	4'-6"	
6'-4"	4'-9"	14'-6"	5'-0"	4'-6"	4'-0"	2'-6"	2'-0"	4'-6"	
6'-9"	4'-11"	15'-0"	5'-0"	4'-6"	4'-0"	2'-6"	2'-0"	4'-6"	
7'-0"	5'-1"	15'-6"	5'-0"	4'-6"	4'-0"	2'-6"	2'-0"	4'-6"	
7'-3"	5'-3"	16'-0"	5'-0"	4'-6"	4'-0"	2'-6"	2'-0"	4'-6"	
7'-8"	5'-5"	16'-6"	5'-0"	4'-6"	4'-0"	2'-6"	2'-0"	4'-6"	
7'-11"	5'-7"	17'-0"	5'-0"	4'-6"	4'-0"	2'-6"	2'-0"	4'-6"	
8'-2"	5'-9"	17'-6"	5'-0"	4'-6"	4'-0"	2'-6"	2'-0"	4'-6"	
8'-7"	5'-11"	18'-0"	5'-0"	4'-6"	4'-0"	2'-6"	2'-0"	4'-6"	
8'-10"	6'-1"	18'-6"	5'-0"	4'-6"	4'-0"	2'-6"	2'-0"	4'-6"	
9'-4"	6'-3"	19'-0"	5'-0"	4'-6"	4'-0"	2'-6"	2'-0"	4'-6"	
9'-6"	6'-5"	19'-6"	5'-0"	4'-6"	4'-0"	2'-6"	2'-0"	4'-6"	
9'-9"	6'-7"	20'-0"	5'-0"	4'-6"	4'-0"	2'-6"	2'-0"	4'-6"	
10'-3"	6'-9"	20'-6"	5'-0"	4'-6"	4'-0"	2'-6"	2'-0"	4'-6"	
10'-8"	6'-11"	21'-0"	5'-6"	5'-0"	4'-0"	3'-0"	2'-0"	5'-0"	
10'-11"	7'-1"	21'-6"	5'-6"	5'-0"	4'-0"	3'-0"	2'-0"	5'-0"	
11'-5"	7'-3"	22'-0"	5'-6"	5'-0"	4'-0"	3'-0"	2'-0"	5'-0"	
11'-7"	7'-5"	22'-6"	5'-6"	5'-0"	4'-0"	3'-0"	2'-0"	5'-0"	
11'-10"	7'-7"	23'-0"	5'-6"	5'-0"	4'-0"	3'-0"	2'-0"	5'-0"	
12'-4"	7'-9"	23'-6"	5'-6"	5'-0"	4'-0"	3'-0"	2'-0"	5'-0"	
12'-6"	7'-11"	24'-0"	5'-6"	5'-0"	4'-0"	3'-0"	2'-0"	5'-0"	
12'-8"	8'-1"	24'-6"	5'-6"	5'-0"	4'-0"	3'-0"	2'-0"	5'-0"	
12'-10"	8'-4"	25'-0"	5'-6"	5'-0"	4'-0"	3'-0"	2'-0"	5'-0"	
13'-5"	8'-5"	25'-6"	5'-6"	5'-0"	4'-0"	3'-0"	2'-0"	5'-0"	
13'-11"	8'-7"	26'-0"	5'-6"	5'-0"	4'-0"	3'-0"	2'-0"	5'-0"	
14'-1"	8'-9"	26'-6"	5'-6"	5'-0"	4'-0"	3'-0"	2'-0"	5'-0"	
14'-3"	8'-11"	27'-0"	5'-6"	5'-0"	4'-0"	3'-0"	2'-0"	5'-0"	
14'-10"	9'-1"	27'-6"	5'-6"	5'-0"	4'-0"	3'-0"	2'-0"	5'-0"	
15'-4"	9'-3"	28'-0"	5'-6"	5'-0"	4'-0"	3'-0"	2'-0"	5'-0"	
15'-6"	9'-5"	28'-6"	5'-6"	5'-0"	4'-0"	3'-0"	2'-0"	5'-0"	
15'-8"	9'-7"	29'-0"	5'-6"	5'-0"	4'-0"	3'-0"	2'-0"	5'-0"	
15'-10"	9'-10"	29'-6"	5'-6"	5'-0"	4'-0"	3'-0"	2'-0"	5'-0"	
16'-5"	9'-11"	30'-0"	5'-6"	5'-0"	4'-0"	3'-0"	2'-0"	5'-0"	
16'-7"	10'-1"	30'-6"	5'-6"	5'-0"	4'-0"	3'-0"	2'-0"	5'-0"	

GENERAL NOTES:

- For use on 2:1 or flatter backfill slopes only.
- See plans for pipe beveling requirements. See Std. Dwg. D-07 for "X" dimension and culvert beveling geometry.
- Use Class A concrete.
- Use epoxy-coated ASTM A706, Grade 60 reinforcing steel $f_y=60,000$ psi.
- Place reinforcement 3" clear from surface of concrete unless otherwise noted.
- Chamfer all exposed concrete corners 3/4".
- If unsuitable foundation material is encountered, remove and backfill with Foundation Fill as directed by the Engineer.
- Furnishing and installing hook bolts in place is incidental to Class A concrete.
- Use galvanized ASTM A307 hook bolts and nuts. Torque culvert nuts to 140 ft-lbs.
- Headwalls for skewed culverts to be parallel to road centerline. See plans for dimensions of openings in headwalls for skewed culverts.
- For backfill soil with:
 $\phi=30^\circ, \gamma=130$ pcf
 Use A1 and D1
 $\phi=34^\circ, \gamma=135$ pcf
 Use A2 and D2

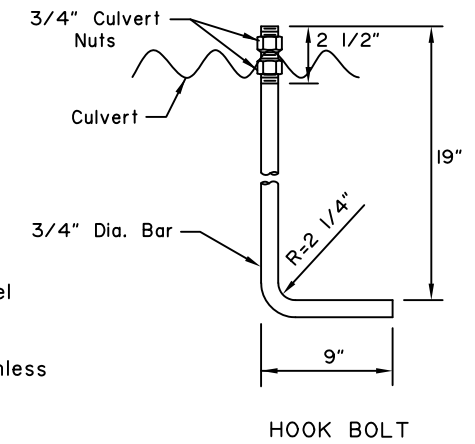

State of Alaska DOT&PF
ALASKA STANDARD PLAN

**HEADWALLS
CAST-IN-PLACE
TYPE I**

Adopted as an Alaska Standard Plan by: *Kenneth J. Fisher*
Kenneth J. Fisher, P.E.
Chief Engineer

Adoption Date: 02/08/2019

Last Code and Stds. Review By: _____ Date: _____

Next Code and Standards Review date: 02/08/2029

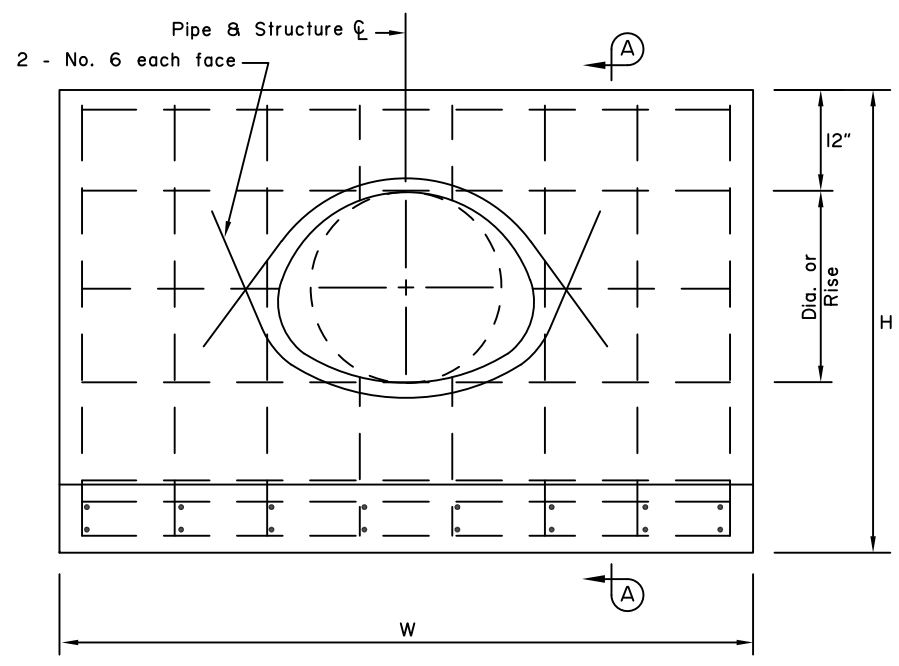

ELEVATION

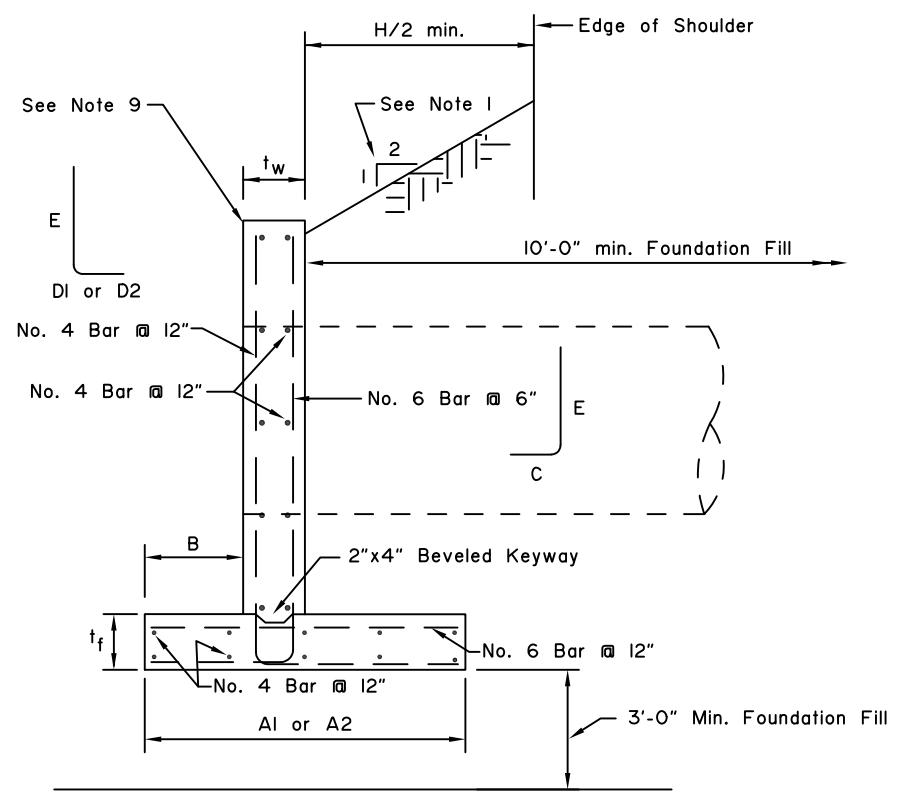

SECTION A-A

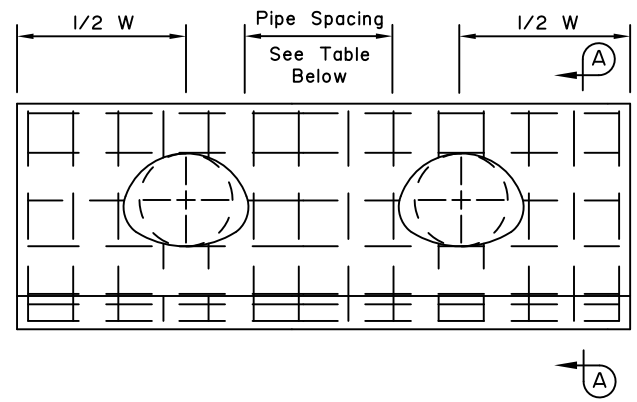

MULTIPLE INSTALLATION

Minimum Space Between Pipes	
1/2 Dia. of Pipe or 1/2 Span of Pipe Arch, 24" Min.	

CORRUGATED METAL PIPE * SEE NOTE 8

Dia.	W	t _w	t _f	H	A1 *	A2 *	B	C	D1 *	D2 *	E
1'-6"	8'-0"	1'-0"	1'-0"	4'-6"	4'-0"	4'-0"	1'-6"	2'-0"	2'-0"	2'-0"	4'-0"
1'-9"	9'-0"	1'-0"	1'-0"	4'-9"	4'-6"	4'-0"	1'-6"	2'-0"	2'-6"	2'-0"	4'-3"
2'-0"	9'-6"	1'-0"	1'-0"	5'-0"	4'-6"	4'-0"	1'-6"	2'-0"	2'-6"	2'-0"	4'-6"
2'-6"	11'-6"	1'-0"	1'-0"	5'-6"	5'-0"	4'-0"	1'-6"	2'-0"	3'-0"	2'-0"	5'-0"
3'-0"	13'-0"	1'-0"	1'-0"	6'-0"	5'-6"	4'-0"	1'-6"	2'-0"	3'-6"	2'-0"	5'-6"
3'-6"	14'-6"	1'-0"	1'-0"	6'-6"	6'-0"	4'-0"	1'-6"	2'-0"	4'-0"	2'-0"	6'-0"
4'-0"	16'-0"	1'-0"	1'-0"	7'-0"	6'-6"	4'-6"	2'-0"	2'-6"	4'-0"	2'-0"	6'-6"
4'-6"	18'-0"	1'-0"	1'-0"	7'-6"	7'-0"	4'-6"	2'-0"	2'-6"	4'-6"	2'-0"	7'-0"
5'-0"	19'-6"	1'-0"	1'-0"	8'-0"	8'-0"	5'-0"	2'-6"	3'-0"	5'-0"	2'-0"	7'-6"
5'-6"	21'-0"	1'-0"	1'-0"	8'-6"	8'-6"	5'-6"	2'-6"	3'-0"	5'-6"	2'-6"	8'-0"
6'-0"	23'-0"	1'-0"	1'-0"	9'-0"	9'-6"	6'-0"	3'-0"	3'-6"	6'-0"	2'-6"	8'-6"
6'-6"	24'-6"	1'-3"	1'-3"	9'-9"	10'-0"	6'-0"	3'-0"	3'-9"	6'-6"	2'-6"	9'-3"
7'-0"	26'-0"	1'-3"	1'-3"	10'-3"	10'-0"	6'-6"	3'-0"	3'-9"	6'-6"	3'-0"	9'-9"
7'-6"	28'-0"	1'-6"	1'-6"	11'-6"	10'-6"	6'-6"	3'-0"	4'-0"	7'-0"	3'-0"	10'-6"
8'-0"	29'-6"	1'-6"	1'-6"	11'-6"	11'-0"	7'-0"	3'-0"	4'-0"	7'-6"	3'-6"	11'-0"
8'-6"	31'-0"	2'-0"	2'-0"	12'-6"	11'-6"	7'-0"	3'-0"	4'-6"	8'-0"	3'-6"	12'-0"
9'-0"	33'-0"	2'-0"	2'-0"	13'-0"	11'-6"	7'-6"	3'-0"	4'-6"	8'-0"	4'-0"	12'-6"

CORRUGATED METAL PIPE ARCH * SEE NOTE 8

SPAN	RISE	W	t _w	t _f	H	A1 *	A2 *	B	C	D1 *	D2 *	E
1'-5"	1'-1"	6'-6"	1'-0"	1'-0"	4'-1"	4'-0"	4'-0"	1'-6"	2'-0"	2'-0"	2'-0"	3'-7"
1'-9"	1'-3"	7'-0"	1'-0"	1'-0"	4'-3"	4'-0"	4'-0"	1'-6"	2'-0"	2'-0"	2'-0"	3'-9"
2'-0"	1'-6"	8'-0"	1'-0"	1'-0"	4'-6"	4'-0"	4'-0"	1'-6"	2'-0"	2'-0"	2'-0"	4'-0"
2'-4"	1'-8"	8'-6"	1'-0"	1'-0"	4'-8"	4'-0"	4'-0"	1'-6"	2'-0"	2'-0"	2'-0"	4'-2"
2'-11"	2'-0"	9'-6"	1'-0"	1'-0"	5'-0"	4'-0"	4'-0"	1'-6"	2'-0"	2'-6"	2'-0"	4'-6"
3'-6"	2'-5"	11'-0"	1'-0"	1'-0"	5'-5"	5'-0"	4'-0"	1'-6"	2'-0"	3'-0"	2'-0"	4'-11"
4'-1"	2'-9"	12'-0"	1'-0"	1'-0"	5'-9"	5'-6"	4'-0"	1'-6"	2'-0"	3'-6"	2'-0"	5'-3"
4'-9"	3'-2"	13'-6"	1'-0"	1'-0"	6'-2"	5'-6"	4'-0"	1'-6"	2'-0"	3'-6"	2'-0"	5'-8"
5'-4"	3'-7"	15'-0"	1'-0"	1'-0"	6'-7"	6'-0"	4'-0"	1'-6"	2'-0"	4'-0"	2'-0"	6'-1"
5'-11"	3'-11"	16'-0"	1'-0"	1'-0"	6'-11"	6'-6"	4'-6"	2'-0"	2'-6"	4'-0"	2'-0"	6'-5"
6'-5"	4'-4"	17'-0"	1'-0"	1'-0"	7'-4"	7'-0"	4'-6"	2'-0"	2'-6"	4'-6"	2'-0"	6'-10"
7'-1"	4'-9"	19'-0"	1'-0"	1'-0"	7'-9"	8'-0"	4'-6"	2'-0"	2'-6"	5'-6"	2'-0"	7'-3"

GENERAL NOTES:

- For use on 2:1 or flatter backfill slopes only.
- Use Class A concrete.
- Use epoxy-coated ASTM A706, Grade 60 reinforcing steel $f_y=60,000$ psi.
- Place reinforcement 3" clear from surface of concrete unless otherwise noted.
- Chamfer all exposed concrete corners 3/4".
- If unsuitable foundation material is encountered, remove and backfill with Foundation Fill as directed by the Engineer.
- Headwalls for skewed culverts to be parallel to road centerline. See plans for dimensions of openings in headwalls for skewed culverts.
- For backfill soil with:
 $\phi=30^\circ, \gamma=130$ pcf
 Use A1 and D1
 $\phi=34^\circ, \gamma=135$ pcf
 Use A2 and D2
- See plans for railing requirements at top of wall.

State of Alaska DOT&PF
ALASKA STANDARD PLAN

**HEADWALLS
CAST-IN-PLACE
TYPE II**

Adopted as an Alaska
Standard Plan by: *Kenneth J. Fisher*
Kenneth J. Fisher, P.E.
Chief Engineer

Adoption Date: 02/08/2019

Last Code and Stds. Review
By: Date:
Next Code and Standards Review date: 02/08/2029

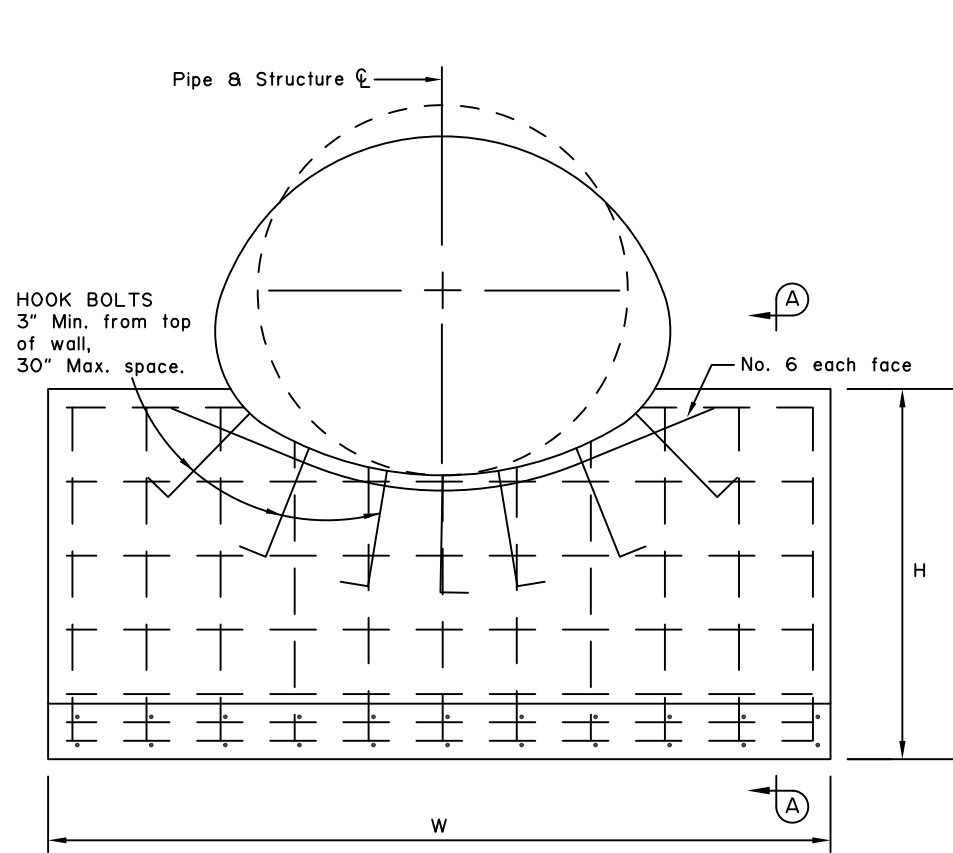

ELEVATION

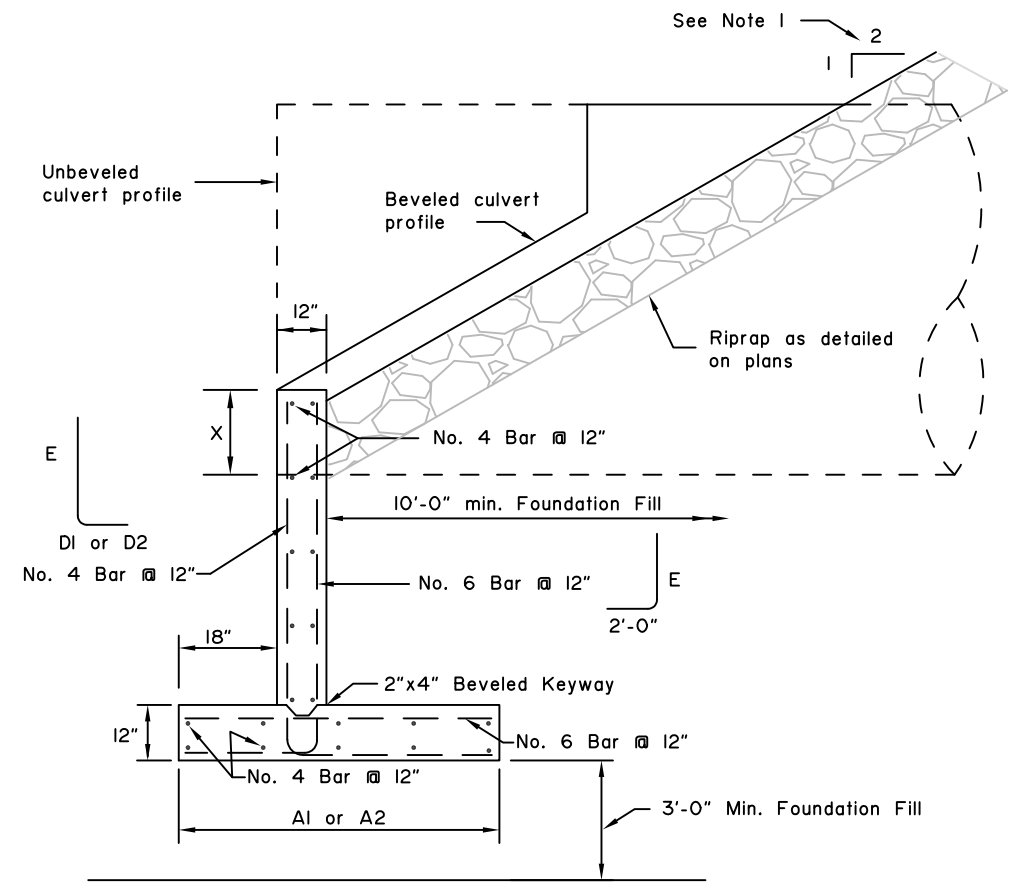

SECTION A-A

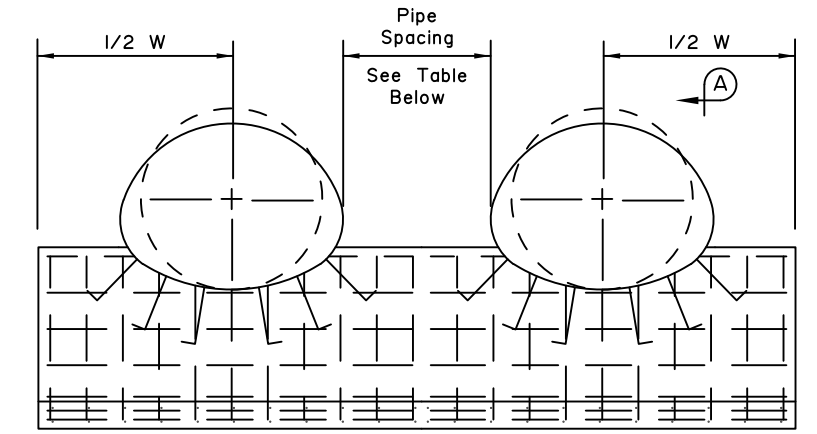

MULTIPLE INSTALLATION

Minimum Space Between Pipes	
1/2 Dia. of Pipe or 1/2 Span of Pipe Arch, 24" Min.	

CORRUGATED METAL PIPE * SEE NOTE II							
Dia.	W	H	A1*	A2*	D1*	D2*	E
5'-0"	9'-0"	4'-0"	4'-0"	4'-0"	2'-0"	2'-0"	3'-6"
5'-6"	10'-0"	4'-6"	4'-0"	4'-0"	2'-0"	2'-0"	4'-0"
6'-0"	11'-0"	4'-6"	4'-0"	4'-0"	2'-0"	2'-0"	4'-0"
6'-6"	12'-0"	4'-6"	4'-0"	4'-0"	2'-0"	2'-0"	4'-0"
7'-0"	12'-6"	4'-6"	4'-0"	4'-0"	2'-0"	2'-0"	4'-0"
7'-6"	13'-6"	5'-0"	4'-6"	4'-0"	2'-6"	2'-0"	4'-6"
8'-0"	14'-6"	5'-0"	4'-6"	4'-0"	2'-6"	2'-0"	4'-6"
8'-6"	15'-6"	5'-0"	4'-6"	4'-0"	2'-6"	2'-0"	4'-6"
9'-0"	16'-6"	5'-6"	5'-0"	4'-0"	3'-0"	2'-0"	5'-0"
9'-6"	17'-0"	5'-6"	5'-0"	4'-0"	3'-0"	2'-0"	5'-0"
10'-0"	18'-0"	5'-6"	5'-0"	4'-0"	3'-0"	2'-0"	5'-0"
10'-6"	19'-0"	5'-6"	5'-0"	4'-0"	3'-0"	2'-0"	5'-0"
11'-0"	20'-0"	5'-6"	5'-0"	4'-0"	3'-0"	2'-0"	5'-0"
11'-6"	21'-0"	5'-6"	5'-0"	4'-0"	3'-0"	2'-0"	5'-0"
12'-0"	21'-6"	5'-6"	5'-0"	4'-0"	3'-0"	2'-0"	5'-0"
12'-6"	22'-6"	5'-6"	5'-0"	4'-0"	3'-0"	2'-0"	5'-0"
13'-0"	23'-6"	5'-6"	5'-0"	4'-0"	3'-0"	2'-0"	5'-0"
13'-6"	24'-6"	6'-0"	5'-6"	4'-0"	3'-6"	2'-0"	5'-6"
14'-0"	25'-6"	6'-6"	6'-0"	4'-0"	4'-0"	2'-0"	6'-0"
14'-6"	26'-0"	6'-6"	6'-0"	4'-0"	4'-0"	2'-0"	6'-0"
15'-0"	27'-0"	6'-6"	6'-0"	4'-0"	4'-0"	2'-0"	6'-0"

CORRUGATED METAL PIPE ARCH * SEE NOTE II									
SPAN	RISE	W	H	A1*	A2*	D1*	D2*	E	
6'-1"	4'-7"	14'-0"	5'-0"	4'-6"	4'-0"	2'-6"	2'-0"	4'-6"	
6'-4"	4'-9"	14'-6"	5'-0"	4'-6"	4'-0"	2'-6"	2'-0"	4'-6"	
6'-9"	4'-11"	15'-0"	5'-0"	4'-6"	4'-0"	2'-6"	2'-0"	4'-6"	
7'-0"	5'-1"	15'-6"	5'-0"	4'-6"	4'-0"	2'-6"	2'-0"	4'-6"	
7'-3"	5'-3"	16'-0"	5'-0"	4'-6"	4'-0"	2'-6"	2'-0"	4'-6"	
7'-8"	5'-5"	16'-6"	5'-0"	4'-6"	4'-0"	2'-6"	2'-0"	4'-6"	
7'-11"	5'-7"	17'-0"	5'-0"	4'-6"	4'-0"	2'-6"	2'-0"	4'-6"	
8'-2"	5'-9"	17'-6"	5'-0"	4'-6"	4'-0"	2'-6"	2'-0"	4'-6"	
8'-7"	5'-11"	18'-0"	5'-0"	4'-6"	4'-0"	2'-6"	2'-0"	4'-6"	
8'-10"	6'-1"	18'-6"	5'-0"	4'-6"	4'-0"	2'-6"	2'-0"	4'-6"	
9'-4"	6'-3"	19'-0"	5'-0"	4'-6"	4'-0"	2'-6"	2'-0"	4'-6"	
9'-6"	6'-5"	19'-6"	5'-0"	4'-6"	4'-0"	2'-6"	2'-0"	4'-6"	
9'-9"	6'-7"	20'-0"	5'-0"	4'-6"	4'-0"	2'-6"	2'-0"	4'-6"	
10'-3"	6'-9"	20'-6"	5'-0"	4'-6"	4'-0"	2'-6"	2'-0"	4'-6"	
10'-8"	6'-11"	21'-0"	5'-6"	5'-0"	4'-0"	3'-0"	2'-0"	5'-0"	
10'-11"	7'-1"	21'-6"	5'-6"	5'-0"	4'-0"	3'-0"	2'-0"	5'-0"	
11'-5"	7'-3"	22'-0"	5'-6"	5'-0"	4'-0"	3'-0"	2'-0"	5'-0"	
11'-7"	7'-5"	22'-6"	5'-6"	5'-0"	4'-0"	3'-0"	2'-0"	5'-0"	
11'-10"	7'-7"	23'-0"	5'-6"	5'-0"	4'-0"	3'-0"	2'-0"	5'-0"	
12'-4"	7'-9"	23'-6"	5'-6"	5'-0"	4'-0"	3'-0"	2'-0"	5'-0"	
12'-6"	7'-11"	24'-0"	5'-6"	5'-0"	4'-0"	3'-0"	2'-0"	5'-0"	
12'-8"	8'-1"	24'-6"	5'-6"	5'-0"	4'-0"	3'-0"	2'-0"	5'-0"	
12'-10"	8'-4"	25'-0"	5'-6"	5'-0"	4'-0"	3'-0"	2'-0"	5'-0"	
13'-5"	8'-5"	25'-6"	5'-6"	5'-0"	4'-0"	3'-0"	2'-0"	5'-0"	
13'-11"	8'-7"	26'-0"	5'-6"	5'-0"	4'-0"	3'-0"	2'-0"	5'-0"	
14'-1"	8'-9"	26'-6"	5'-6"	5'-0"	4'-0"	3'-0"	2'-0"	5'-0"	
14'-3"	8'-11"	27'-0"	5'-6"	5'-0"	4'-0"	3'-0"	2'-0"	5'-0"	
14'-10"	9'-1"	27'-6"	5'-6"	5'-0"	4'-0"	3'-0"	2'-0"	5'-0"	
15'-4"	9'-3"	28'-0"	5'-6"	5'-0"	4'-0"	3'-0"	2'-0"	5'-0"	
15'-6"	9'-5"	28'-6"	5'-6"	5'-0"	4'-0"	3'-0"	2'-0"	5'-0"	
15'-8"	9'-7"	29'-0"	5'-6"	5'-0"	4'-0"	3'-0"	2'-0"	5'-0"	
15'-10"	9'-10"	29'-6"	5'-6"	5'-0"	4'-0"	3'-0"	2'-0"	5'-0"	
16'-5"	9'-11"	30'-0"	5'-6"	5'-0"	4'-0"	3'-0"	2'-0"	5'-0"	
16'-7"	10'-1"	30'-6"	5'-6"	5'-0"	4'-0"	3'-0"	2'-0"	5'-0"	

GENERAL NOTES:

- For use on 2:1 or flatter backfill slopes only.
- See plans for pipe beveling requirements. See Std. Dwg. D-07 for "X" dimension and culvert beveling geometry.
- Use Class A concrete.
- Use epoxy-coated ASTM A706, Grade 60 reinforcing steel $f_y=60,000$ psi.
- Place reinforcement 3" clear from surface of concrete unless otherwise noted.
- Chamfer all exposed concrete corners 3/4".
- If unsuitable foundation material is encountered, remove and backfill with Foundation Fill as directed by the Engineer.
- Furnishing and installing hook bolts in place is incidental to Class A concrete.
- Use galvanized ASTM A307 hook bolts and nuts. Torque culvert nuts to 140 ft-lbs.
- Headwalls for skewed culverts to be parallel to road centerline. See plans for dimensions of openings in headwalls for skewed culverts.
- For backfill soil with:
 $\phi=30^\circ, \gamma=130$ pcf
 Use A1 and D1
 $\phi=34^\circ, \gamma=135$ pcf
 Use A2 and D2

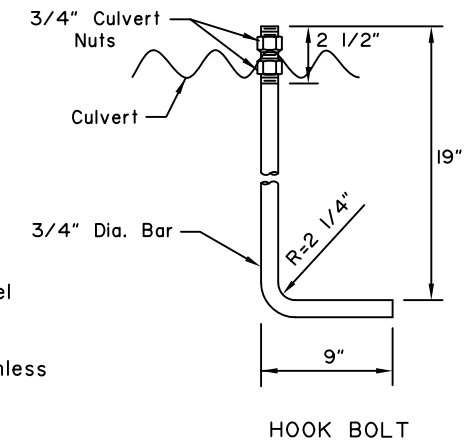

State of Alaska DOT&PF
ALASKA STANDARD PLAN

**HEADWALLS
CAST-IN-PLACE
TYPE I**

Adopted as an Alaska Standard Plan by: *Kenneth J. Fisher*
Kenneth J. Fisher, P.E.
Chief Engineer

Adoption Date: 02/08/2019

Last Code and Stds. Review By: _____ Date: _____

Next Code and Standards Review date: 02/08/2029

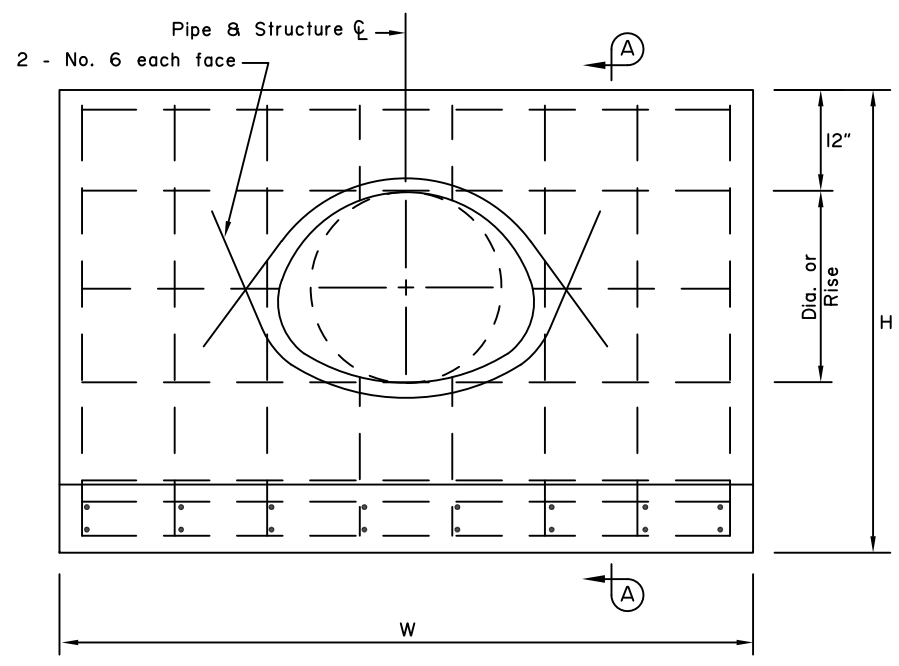

ELEVATION

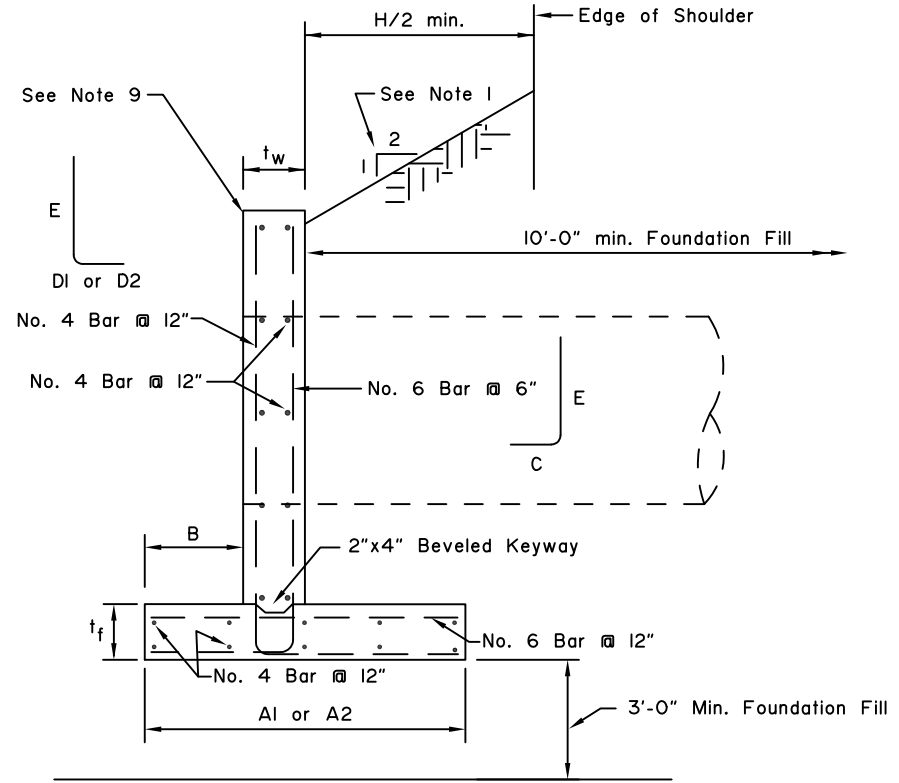

SECTION A-A

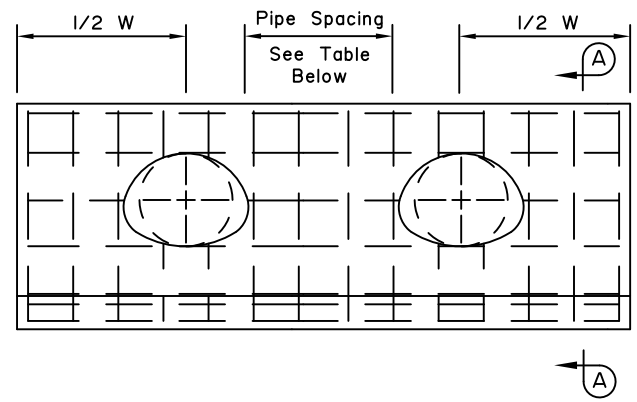

MULTIPLE INSTALLATION

Minimum Space Between Pipes	
1/2 Dia. of Pipe or 1/2 Span of Pipe Arch, 24" Min.	

CORRUGATED METAL PIPE * SEE NOTE 8

Dia.	W	t _w	t _f	H	A1 *	A2 *	B	C	D1 *	D2 *	E
1'-6"	8'-0"	1'-0"	1'-0"	4'-6"	4'-0"	4'-0"	1'-6"	2'-0"	2'-0"	2'-0"	4'-0"
1'-9"	9'-0"	1'-0"	1'-0"	4'-9"	4'-6"	4'-0"	1'-6"	2'-0"	2'-6"	2'-0"	4'-3"
2'-0"	9'-6"	1'-0"	1'-0"	5'-0"	4'-6"	4'-0"	1'-6"	2'-0"	2'-6"	2'-0"	4'-6"
2'-6"	11'-6"	1'-0"	1'-0"	5'-6"	5'-0"	4'-0"	1'-6"	2'-0"	3'-0"	2'-0"	5'-0"
3'-0"	13'-0"	1'-0"	1'-0"	6'-0"	5'-6"	4'-0"	1'-6"	2'-0"	3'-6"	2'-0"	5'-6"
3'-6"	14'-6"	1'-0"	1'-0"	6'-6"	6'-0"	4'-0"	1'-6"	2'-0"	4'-0"	2'-0"	6'-0"
4'-0"	16'-0"	1'-0"	1'-0"	7'-0"	6'-6"	4'-6"	2'-0"	2'-6"	4'-0"	2'-0"	6'-6"
4'-6"	18'-0"	1'-0"	1'-0"	7'-6"	7'-0"	4'-6"	2'-0"	2'-6"	4'-6"	2'-0"	7'-0"
5'-0"	19'-6"	1'-0"	1'-0"	8'-0"	8'-0"	5'-0"	2'-6"	3'-0"	5'-0"	2'-0"	7'-6"
5'-6"	21'-0"	1'-0"	1'-0"	8'-6"	8'-6"	5'-6"	2'-6"	3'-0"	5'-6"	2'-6"	8'-0"
6'-0"	23'-0"	1'-0"	1'-0"	9'-0"	9'-6"	6'-0"	3'-0"	3'-6"	6'-0"	2'-6"	8'-6"
6'-6"	24'-6"	1'-3"	1'-3"	9'-9"	10'-0"	6'-0"	3'-0"	3'-9"	6'-6"	2'-6"	9'-3"
7'-0"	26'-0"	1'-3"	1'-3"	10'-3"	10'-0"	6'-6"	3'-0"	3'-9"	6'-6"	3'-0"	9'-9"
7'-6"	28'-0"	1'-6"	1'-6"	11'-6"	10'-6"	6'-6"	3'-0"	4'-0"	7'-0"	3'-0"	10'-6"
8'-0"	29'-6"	1'-6"	1'-6"	11'-6"	11'-0"	7'-0"	3'-0"	4'-0"	7'-6"	3'-6"	11'-0"
8'-6"	31'-0"	2'-0"	2'-0"	12'-6"	11'-6"	7'-0"	3'-0"	4'-6"	8'-0"	3'-6"	12'-0"
9'-0"	33'-0"	2'-0"	2'-0"	13'-0"	11'-6"	7'-6"	3'-0"	4'-6"	8'-0"	4'-0"	12'-6"

CORRUGATED METAL PIPE ARCH * SEE NOTE 8

SPAN	RISE	W	t _w	t _f	H	A1 *	A2 *	B	C	D1 *	D2 *	E
1'-5"	1'-1"	6'-6"	1'-0"	1'-0"	4'-1"	4'-0"	4'-0"	1'-6"	2'-0"	2'-0"	2'-0"	3'-7"
1'-9"	1'-3"	7'-0"	1'-0"	1'-0"	4'-3"	4'-0"	4'-0"	1'-6"	2'-0"	2'-0"	2'-0"	3'-9"
2'-0"	1'-6"	8'-0"	1'-0"	1'-0"	4'-6"	4'-0"	4'-0"	1'-6"	2'-0"	2'-0"	2'-0"	4'-0"
2'-4"	1'-8"	8'-6"	1'-0"	1'-0"	4'-8"	4'-0"	4'-0"	1'-6"	2'-0"	2'-0"	2'-0"	4'-2"
2'-11"	2'-0"	9'-6"	1'-0"	1'-0"	5'-0"	4'-6"	4'-0"	1'-6"	2'-0"	2'-6"	2'-0"	4'-6"
3'-6"	2'-5"	11'-0"	1'-0"	1'-0"	5'-5"	5'-0"	4'-0"	1'-6"	2'-0"	3'-0"	2'-0"	4'-11"
4'-1"	2'-9"	12'-0"	1'-0"	1'-0"	5'-9"	5'-6"	4'-0"	1'-6"	2'-0"	3'-6"	2'-0"	5'-3"
4'-9"	3'-2"	13'-6"	1'-0"	1'-0"	6'-2"	5'-6"	4'-0"	1'-6"	2'-0"	3'-6"	2'-0"	5'-8"
5'-4"	3'-7"	15'-0"	1'-0"	1'-0"	6'-7"	6'-0"	4'-0"	1'-6"	2'-0"	4'-0"	2'-0"	6'-1"
5'-11"	3'-11"	16'-0"	1'-0"	1'-0"	6'-11"	6'-6"	4'-6"	2'-0"	2'-6"	4'-0"	2'-0"	6'-5"
6'-5"	4'-4"	17'-0"	1'-0"	1'-0"	7'-4"	7'-0"	4'-6"	2'-0"	2'-6"	4'-6"	2'-0"	6'-10"
7'-1"	4'-9"	19'-0"	1'-0"	1'-0"	7'-9"	8'-0"	4'-6"	2'-0"	2'-6"	5'-6"	2'-0"	7'-3"

GENERAL NOTES:

- For use on 2:1 or flatter backfill slopes only.
- Use Class A concrete.
- Use epoxy-coated ASTM A706, Grade 60 reinforcing steel $f_y=60,000$ psi.
- Place reinforcement 3" clear from surface of concrete unless otherwise noted.
- Chamfer all exposed concrete corners 3/4".
- If unsuitable foundation material is encountered, remove and backfill with Foundation Fill as directed by the Engineer.
- Headwalls for skewed culverts to be parallel to road centerline. See plans for dimensions of openings in headwalls for skewed culverts.
- For backfill soil with:
 $\phi=30^\circ, \gamma=130$ pcf
 Use A1 and D1
 $\phi=34^\circ, \gamma=135$ pcf
 Use A2 and D2
- See plans for railing requirements at top of wall.

State of Alaska DOT&PF
ALASKA STANDARD PLAN

**HEADWALLS
CAST-IN-PLACE
TYPE II**

Adopted as an Alaska
Standard Plan by: *Kenneth J. Fisher*
Kenneth J. Fisher, P.E.
Chief Engineer

Adoption Date: 02/08/2019

Last Code and Stds. Review
By: _____ Date: _____

Next Code and Standards Review date: 02/08/2029

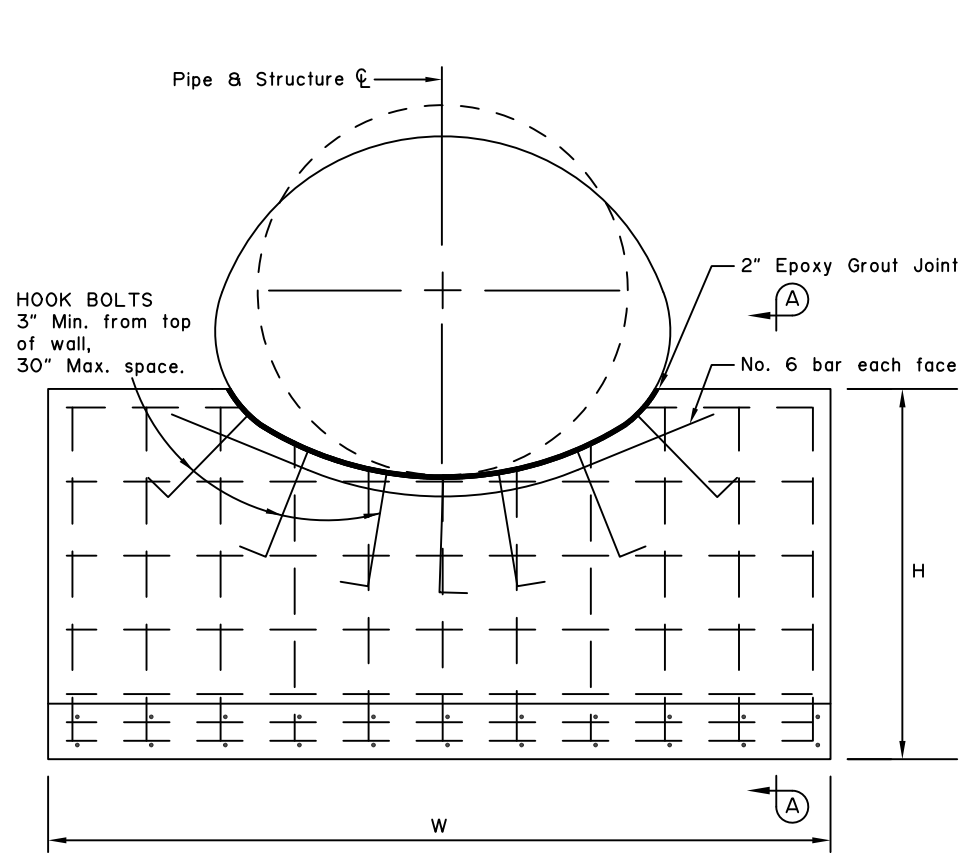

ELEVATION

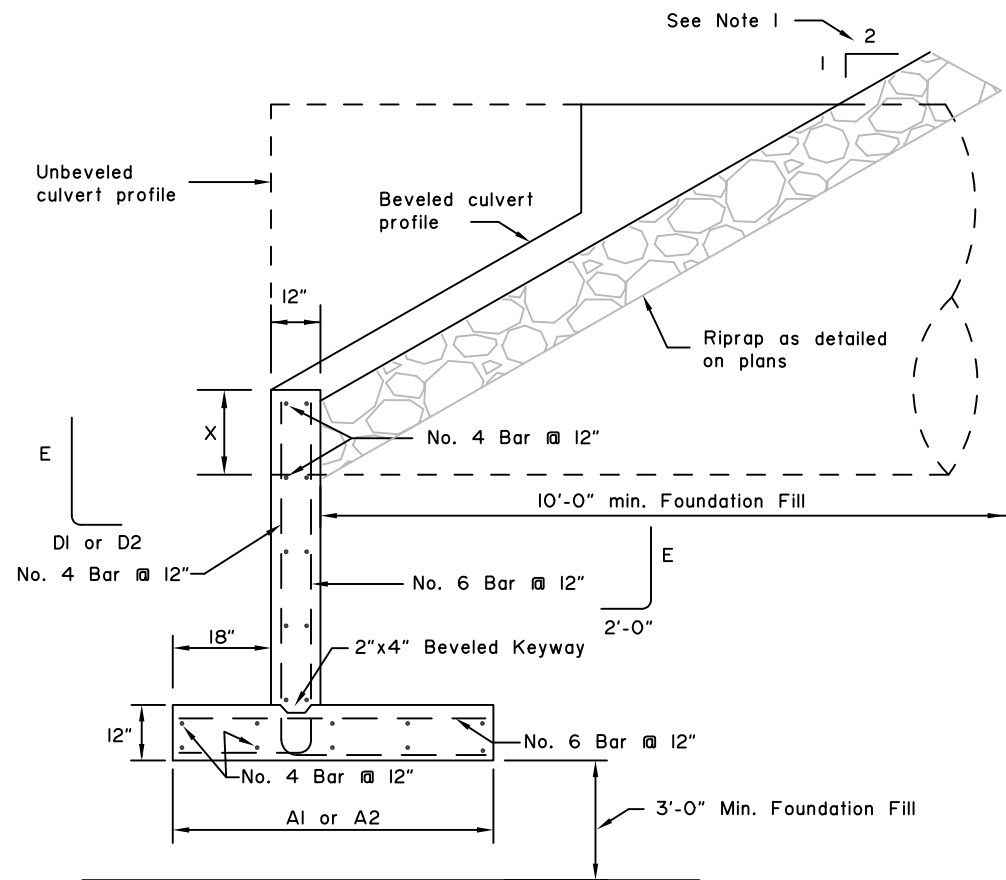

SECTION A-A

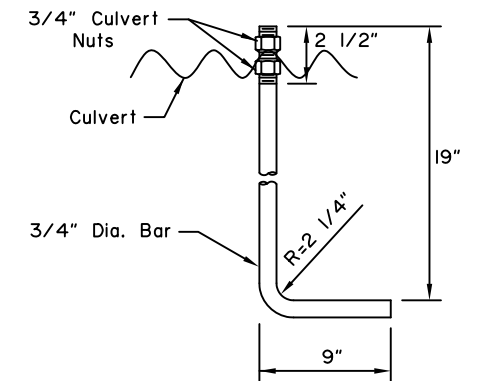

HOOK BOLT

CORRUGATED METAL PIPE * SEE NOTE II							
Dia.	W	H	A1 *	A2 *	D1 *	D2 *	E
5'-0"	9'-0"	4'-0"	4'-0"	4'-0"	2'-0"	2'-0"	3'-6"
5'-6"	10'-0"	4'-6"	4'-0"	4'-0"	2'-0"	2'-0"	4'-0"
6'-0"	11'-0"	4'-6"	4'-0"	4'-0"	2'-0"	2'-0"	4'-0"
6'-6"	12'-0"	4'-6"	4'-0"	4'-0"	2'-0"	2'-0"	4'-0"
7'-0"	12'-6"	4'-6"	4'-0"	4'-0"	2'-0"	2'-0"	4'-0"
7'-6"	13'-6"	5'-0"	4'-6"	4'-0"	2'-6"	2'-0"	4'-6"
8'-0"	14'-6"	5'-0"	4'-6"	4'-0"	2'-6"	2'-0"	4'-6"
8'-6"	15'-6"	5'-0"	4'-6"	4'-0"	2'-6"	2'-0"	4'-6"
9'-0"	16'-6"	5'-6"	5'-0"	4'-0"	3'-0"	2'-0"	5'-0"
9'-6"	17'-0"	5'-6"	5'-0"	4'-0"	3'-0"	2'-0"	5'-0"
10'-0"	18'-0"	5'-6"	5'-0"	4'-0"	3'-0"	2'-0"	5'-0"
10'-6"	19'-0"	5'-6"	5'-0"	4'-0"	3'-0"	2'-0"	5'-0"
11'-0"	20'-0"	5'-6"	5'-0"	4'-0"	3'-0"	2'-0"	5'-0"

CORRUGATED METAL PIPE ARCH * SEE NOTE II								
SPAN	RISE	W	H	A1 *	A2 *	D1 *	D2 *	E
6'-1"	4'-7"	14'-0"	5'-0"	4'-6"	4'-0"	2'-6"	2'-0"	4'-6"
6'-4"	4'-9"	14'-6"	5'-0"	4'-6"	4'-0"	2'-6"	2'-0"	4'-6"
6'-9"	4'-11"	15'-0"	5'-0"	4'-6"	4'-0"	2'-6"	2'-0"	4'-6"
7'-0"	5'-1"	15'-6"	5'-0"	4'-6"	4'-0"	2'-6"	2'-0"	4'-6"
7'-3"	5'-3"	16'-0"	5'-0"	4'-6"	4'-0"	2'-6"	2'-0"	4'-6"
7'-8"	5'-5"	16'-6"	5'-0"	4'-6"	4'-0"	2'-6"	2'-0"	4'-6"
7'-11"	5'-7"	17'-0"	5'-0"	4'-6"	4'-0"	2'-6"	2'-0"	4'-6"
8'-2"	5'-9"	17'-6"	5'-0"	4'-6"	4'-0"	2'-6"	2'-0"	4'-6"
8'-7"	5'-11"	18'-0"	5'-0"	4'-6"	4'-0"	2'-6"	2'-0"	4'-6"
8'-10"	6'-1"	18'-6"	5'-0"	4'-6"	4'-0"	2'-6"	2'-0"	4'-6"
9'-4"	6'-3"	19'-0"	5'-0"	4'-6"	4'-0"	2'-6"	2'-0"	4'-6"
9'-6"	6'-5"	19'-6"	5'-0"	4'-6"	4'-0"	2'-6"	2'-0"	4'-6"
9'-9"	6'-7"	20'-0"	5'-0"	4'-6"	4'-0"	2'-6"	2'-0"	4'-6"
10'-3"	6'-9"	20'-6"	5'-0"	4'-6"	4'-0"	2'-6"	2'-0"	4'-6"
10'-8"	6'-11"	21'-0"	5'-6"	5'-0"	4'-0"	3'-0"	2'-0"	5'-0"
10'-11"	7'-1"	21'-6"	5'-6"	5'-0"	4'-0"	3'-0"	2'-0"	5'-0"

GENERAL NOTES:

- For use on 2:1 or flatter backfill slopes only.
- See plans for pipe beveling requirements. See Std. Dwg. D-07 for "X" dimension and culvert beveling geometry.
- Use Class A concrete.
- Use epoxy-coated ASTM A706, Grade 60 reinforcing steel $f_y=60,000$ psi.
- Place reinforcement 3" clear from surface of concrete unless otherwise noted.
- Chamfer all exposed concrete corners 3/4".
- If unsuitable foundation material is encountered, remove and backfill with Foundation Fill as directed by the Engineer.
- Furnishing and installing hook bolts in place is incidental to Class A concrete.
- Use galvanized ASTM A307 hook bolts and nuts. Torque culvert nuts to 140 ft-lbs.
- Headwalls for skewed culverts to be parallel to road centerline. See plans for dimensions of openings in headwalls for skewed culverts.
- For backfill soil with:
 $\phi=30^\circ, \gamma=130$ pcf
 Use A1 and D1
 $\phi=34^\circ, \gamma=135$ pcf
 Use A2 and D2

State of Alaska DOT&PF
ALASKA STANDARD PLAN
HEADWALLS
PRECAST
TYPE I

Adopted as an Alaska Standard Plan by: *Kenneth J. Fisher*
Kenneth J. Fisher, P.E.
Chief Engineer

Adoption Date: 02/08/2019

Last Code and Stds. Review By: Date:

Next Code and Standards Review date: 02/08/2029

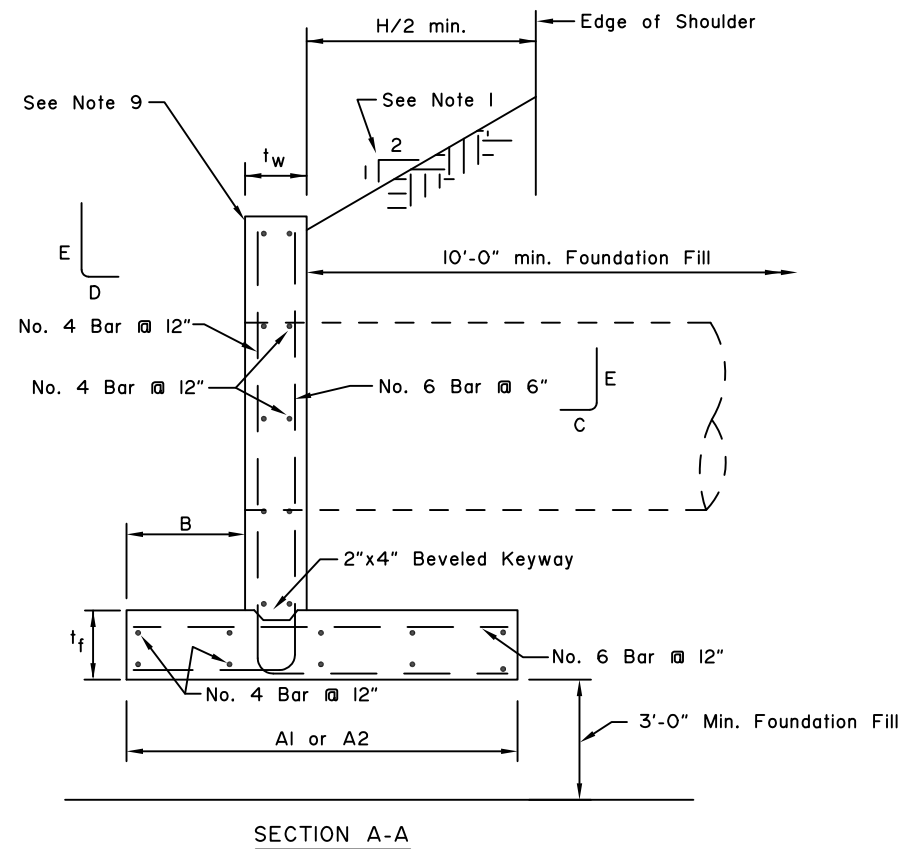
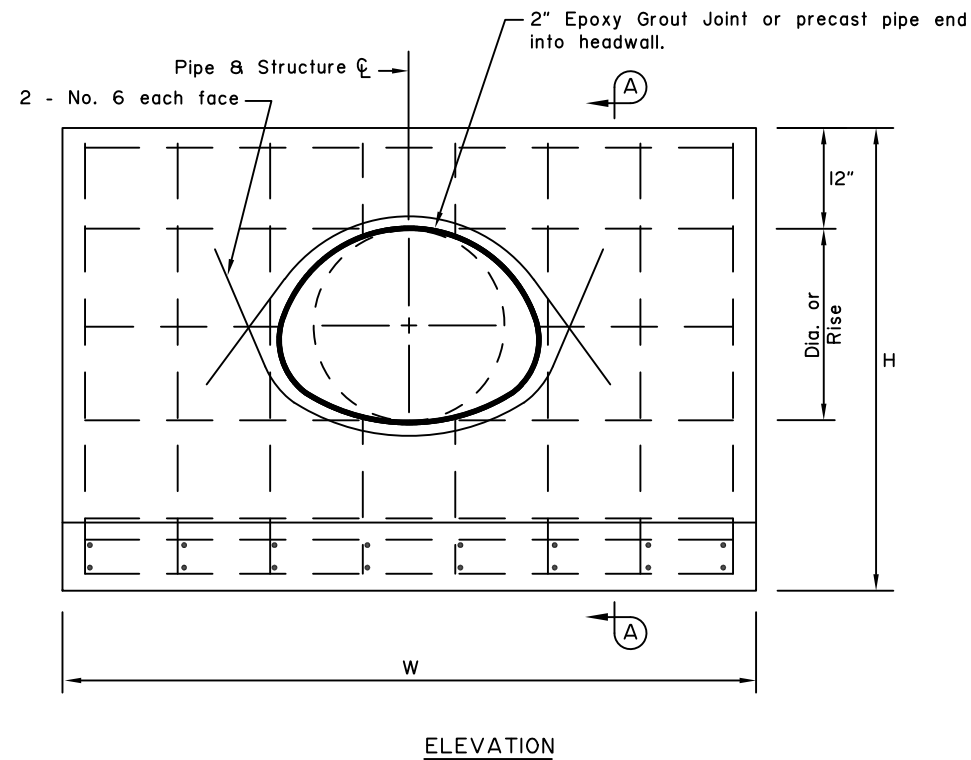

CORRUGATED METAL PIPE * SEE NOTE 8

Dia.	W	t _w	t _f	H	A1*	A2*	B	C	D1*	D2*	E
1'-6"	8'-0"	1'-0"	1'-0"	4'-6"	6'-0"	4'-0"	1'-6"	2'-0"	4'-0"	2'-0"	4'-0"
1'-9"	9'-0"	1'-0"	1'-0"	4'-9"	6'-6"	4'-0"	1'-6"	2'-0"	4'-6"	2'-0"	4'-3"
2'-0"	9'-6"	1'-0"	1'-0"	5'-0"	7'-0"	4'-0"	1'-6"	2'-0"	5'-0"	2'-0"	4'-6"
2'-6"	11'-6"	1'-0"	1'-0"	5'-6"	7'-6"	4'-0"	1'-6"	2'-0"	5'-6"	2'-0"	5'-0"
3'-0"	13'-0"	1'-0"	1'-0"	6'-0"	8'-6"	4'-6"	1'-6"	2'-0"	6'-6"	2'-6"	5'-6"
3'-6"	14'-6"	1'-0"	1'-0"	6'-6"	9'-0"	5'-0"	1'-6"	2'-0"	7'-0"	3'-0"	6'-0"
4'-0"	16'-0"	1'-0"	1'-0"	7'-0"	10'-0"	5'-6"	2'-0"	2'-6"	7'-6"	3'-0"	6'-6"
4'-6"	18'-0"	1'-3"	1'-3"	7'-9"	11'-0"	6'-0"	2'-0"	2'-9"	8'-6"	3'-6"	7'-3"
5'-0"	19'-6"	1'-6"	1'-6"	8'-6"	12'-0"	6'-6"	2'-6"	3'-6"	9'-0"	3'-6"	8'-0"

CORRUGATED METAL PIPE ARCH * SEE NOTE 8

SPAN	RISE	W	t _w	t _f	H	A1*	A2*	B	C	D1*	D2*	E
1'-5"	1'-1"	6'-6"	1'-0"	1'-0"	4'-1"	5'-6"	4'-0"	1'-6"	2'-0"	3'-6"	2'-0"	3'-7"
1'-9"	1'-3"	7'-0"	1'-0"	1'-0"	4'-3"	5'-6"	4'-0"	1'-6"	2'-0"	3'-6"	2'-0"	3'-9"
2'-0"	1'-6"	8'-0"	1'-0"	1'-0"	4'-6"	6'-0"	4'-0"	1'-6"	2'-0"	4'-0"	2'-0"	4'-0"
2'-4"	1'-8"	8'-6"	1'-0"	1'-0"	4'-8"	6'-0"	4'-0"	1'-6"	2'-0"	4'-0"	2'-0"	4'-2"
2'-11"	2'-0"	9'-6"	1'-0"	1'-0"	5'-0"	7'-0"	4'-0"	1'-6"	2'-0"	5'-0"	2'-0"	4'-6"
3'-6"	2'-5"	11'-0"	1'-0"	1'-0"	5'-5"	7'-6"	4'-0"	1'-6"	2'-0"	5'-6"	2'-0"	4'-11"
4'-1"	2'-9"	12'-0"	1'-0"	1'-0"	5'-9"	8'-0"	4'-0"	1'-6"	2'-0"	6'-0"	2'-6"	5'-3"
4'-9"	3'-2"	13'-6"	1'-0"	1'-0"	6'-2"	8'-6"	4'-0"	1'-6"	2'-0"	6'-6"	2'-6"	5'-8"
5'-4"	3'-7"	15'-0"	1'-0"	1'-0"	6'-7"	9'-0"	5'-0"	1'-6"	2'-0"	7'-0"	3'-0"	6'-1"
5'-11"	3'-11"	16'-0"	1'-0"	1'-0"	6'-11"	10'-0"	5'-6"	2'-0"	2'-6"	7'-6"	3'-0"	6'-5"
6'-5"	4'-4"	17'-0"	1'-3"	1'-3"	7'-7"	10'-6"	5'-6"	2'-0"	2'-9"	8'-0"	3'-0"	7'-1"
7'-1"	4'-9"	19'-0"	1'-6"	1'-6"	8'-3"	11'-6"	6'-6"	2'-6"	3'-6"	8'-6"	3'-6"	7'-9"

GENERAL NOTES:

- For use on 2:1 or flatter backfill slopes only.
- Use Class A concrete.
- Use epoxy-coated ASTM A706, Grade 60 reinforcing steel $f_y=60,000$ psi.
- Place reinforcement 3" clear from surface of concrete unless otherwise noted.
- Chamfer all exposed concrete corners 3/4".
- If unsuitable foundation material is encountered, remove and backfill with Foundation Fill as directed by the Engineer.
- Headwalls for skewed culverts to be parallel to road centerline. See plans for dimensions of openings in headwalls for skewed culverts.
- For backfill soil with:
 $\phi=30^\circ, \gamma=130$ pcf
 Use A1 and D1
 $\phi=34^\circ, \gamma=135$ pcf
 Use A2 and D2
- See plans for railing requirements.

State of Alaska DOT&PF
ALASKA STANDARD PLAN

HEADWALLS
PRECAST
TYPE II

Adopted as an Alaska
Standard Plan by: *Kenneth J. Fisher*
Kenneth J. Fisher, P.E.
Chief Engineer

Adoption Date: 02/08/2019

Last Code and Stds. Review
By: Date:

Next Code and Standards Review date: 02/08/2029

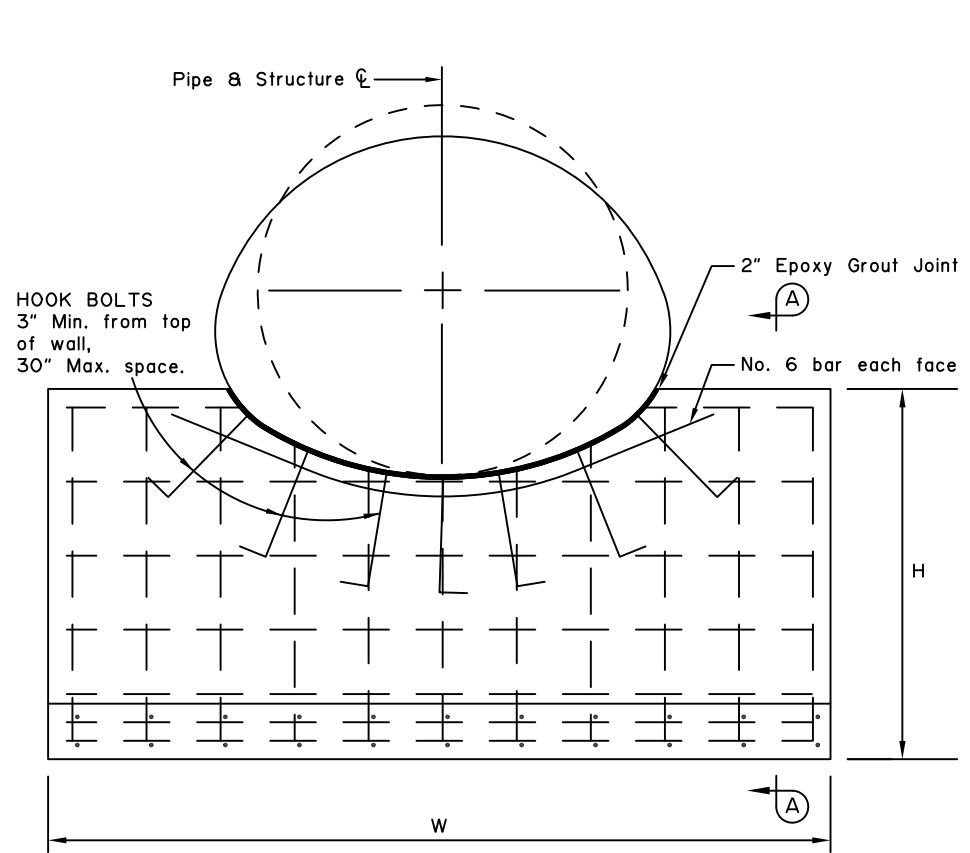

ELEVATION

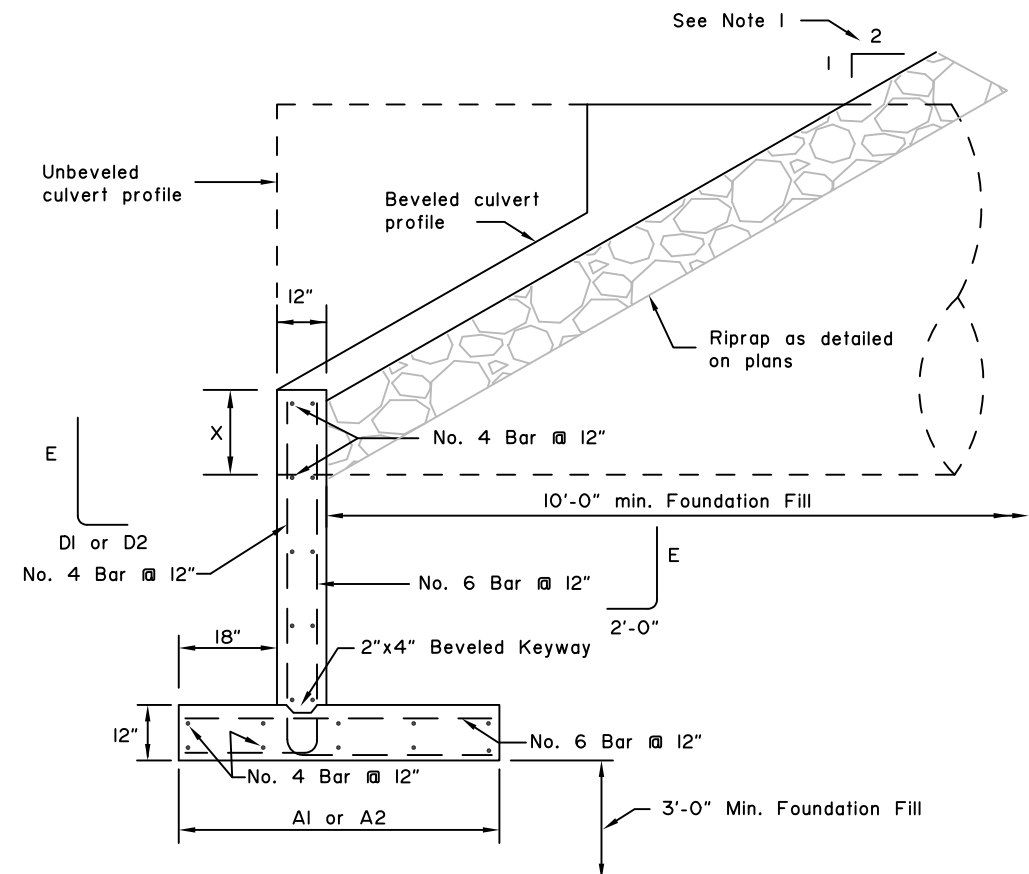

SECTION A-A

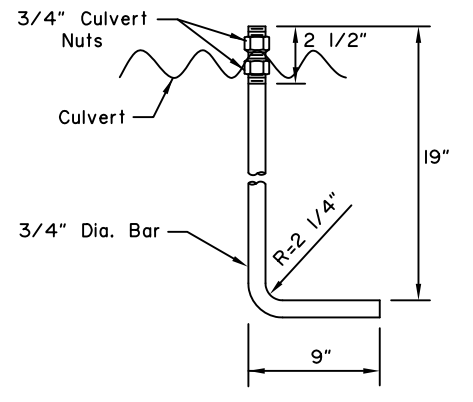

HOOK BOLT

CORRUGATED METAL PIPE * SEE NOTE II							
Dia.	W	H	A1 *	A2 *	D1 *	D2 *	E
5'-0"	9'-0"	4'-0"	4'-0"	4'-0"	2'-0"	2'-0"	3'-6"
5'-6"	10'-0"	4'-6"	4'-0"	4'-0"	2'-0"	2'-0"	4'-0"
6'-0"	11'-0"	4'-6"	4'-0"	4'-0"	2'-0"	2'-0"	4'-0"
6'-6"	12'-0"	4'-6"	4'-0"	4'-0"	2'-0"	2'-0"	4'-0"
7'-0"	12'-6"	4'-6"	4'-0"	4'-0"	2'-0"	2'-0"	4'-0"
7'-6"	13'-6"	5'-0"	4'-6"	4'-0"	2'-6"	2'-0"	4'-6"
8'-0"	14'-6"	5'-0"	4'-6"	4'-0"	2'-6"	2'-0"	4'-6"
8'-6"	15'-6"	5'-0"	4'-6"	4'-0"	2'-6"	2'-0"	4'-6"
9'-0"	16'-6"	5'-6"	5'-0"	4'-0"	3'-0"	2'-0"	5'-0"
9'-6"	17'-0"	5'-6"	5'-0"	4'-0"	3'-0"	2'-0"	5'-0"
10'-0"	18'-0"	5'-6"	5'-0"	4'-0"	3'-0"	2'-0"	5'-0"
10'-6"	19'-0"	5'-6"	5'-0"	4'-0"	3'-0"	2'-0"	5'-0"
11'-0"	20'-0"	5'-6"	5'-0"	4'-0"	3'-0"	2'-0"	5'-0"

CORRUGATED METAL PIPE ARCH * SEE NOTE II								
SPAN	RISE	W	H	A1 *	A2 *	D1 *	D2 *	E
6'-1"	4'-7"	14'-0"	5'-0"	4'-6"	4'-0"	2'-6"	2'-0"	4'-6"
6'-4"	4'-9"	14'-6"	5'-0"	4'-6"	4'-0"	2'-6"	2'-0"	4'-6"
6'-9"	4'-11"	15'-0"	5'-0"	4'-6"	4'-0"	2'-6"	2'-0"	4'-6"
7'-0"	5'-1"	15'-6"	5'-0"	4'-6"	4'-0"	2'-6"	2'-0"	4'-6"
7'-3"	5'-3"	16'-0"	5'-0"	4'-6"	4'-0"	2'-6"	2'-0"	4'-6"
7'-8"	5'-5"	16'-6"	5'-0"	4'-6"	4'-0"	2'-6"	2'-0"	4'-6"
7'-11"	5'-7"	17'-0"	5'-0"	4'-6"	4'-0"	2'-6"	2'-0"	4'-6"
8'-2"	5'-9"	17'-6"	5'-0"	4'-6"	4'-0"	2'-6"	2'-0"	4'-6"
8'-7"	5'-11"	18'-0"	5'-0"	4'-6"	4'-0"	2'-6"	2'-0"	4'-6"
8'-10"	6'-1"	18'-6"	5'-0"	4'-6"	4'-0"	2'-6"	2'-0"	4'-6"
9'-4"	6'-3"	19'-0"	5'-0"	4'-6"	4'-0"	2'-6"	2'-0"	4'-6"
9'-6"	6'-5"	19'-6"	5'-0"	4'-6"	4'-0"	2'-6"	2'-0"	4'-6"
9'-9"	6'-7"	20'-0"	5'-0"	4'-6"	4'-0"	2'-6"	2'-0"	4'-6"
10'-3"	6'-9"	20'-6"	5'-0"	4'-6"	4'-0"	2'-6"	2'-0"	4'-6"
10'-8"	6'-11"	21'-0"	5'-6"	5'-0"	4'-0"	3'-0"	2'-0"	5'-0"
10'-11"	7'-1"	21'-6"	5'-6"	5'-0"	4'-0"	3'-0"	2'-0"	5'-0"

GENERAL NOTES:

- For use on 2:1 or flatter backfill slopes only.
- See plans for pipe beveling requirements. See Std. Dwg. D-07 for "X" dimension and culvert beveling geometry.
- Use Class A concrete.
- Use epoxy-coated ASTM A706, Grade 60 reinforcing steel $f_y=60,000$ psi.
- Place reinforcement 3" clear from surface of concrete unless otherwise noted.
- Chamfer all exposed concrete corners 3/4".
- If unsuitable foundation material is encountered, remove and backfill with Foundation Fill as directed by the Engineer.
- Furnishing and installing hook bolts in place is incidental to Class A concrete.
- Use galvanized ASTM A307 hook bolts and nuts. Torque culvert nuts to 140 ft-lbs.
- Headwalls for skewed culverts to be parallel to road centerline. See plans for dimensions of openings in headwalls for skewed culverts.
- For backfill soil with:
 $\phi=30^\circ, \gamma=130$ pcf
 Use A1 and D1
 $\phi=34^\circ, \gamma=135$ pcf
 Use A2 and D2

State of Alaska DOT&PF
 ALASKA STANDARD PLAN
**HEADWALLS
 PRECAST
 TYPE I**

Adopted as an Alaska Standard Plan by: *Kenneth J. Fisher*
 Kenneth J. Fisher, P.E.
 Chief Engineer

Adoption Date: 02/08/2019

Last Code and Stds. Review By: _____ Date: _____

Next Code and Standards Review date: 02/08/2029

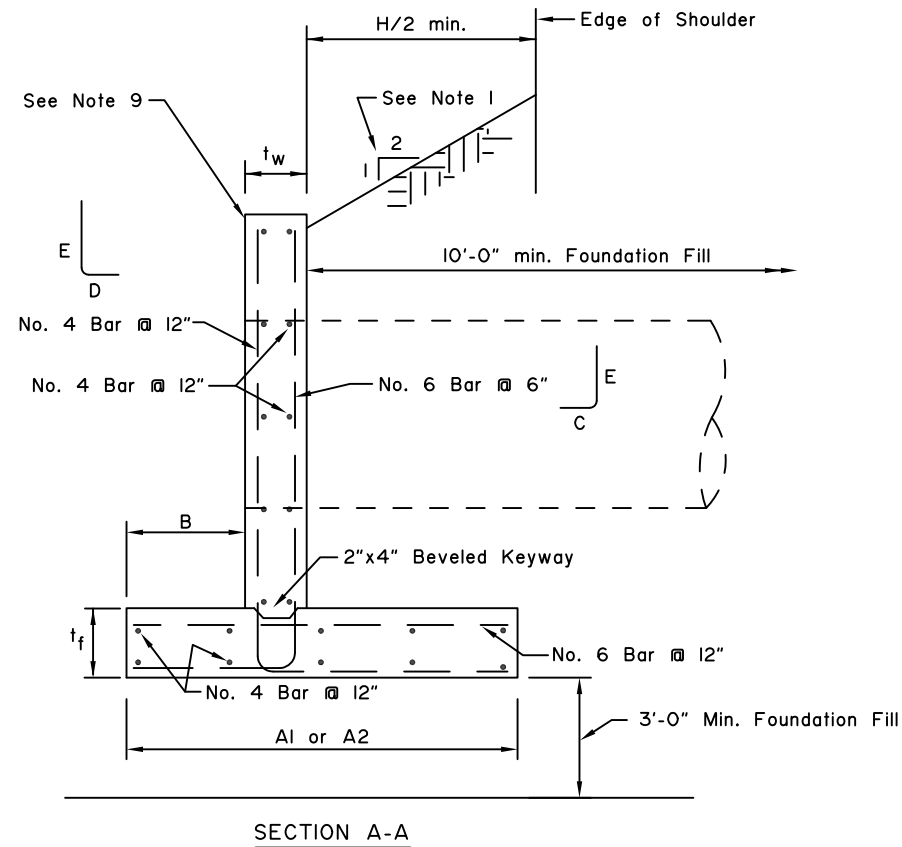
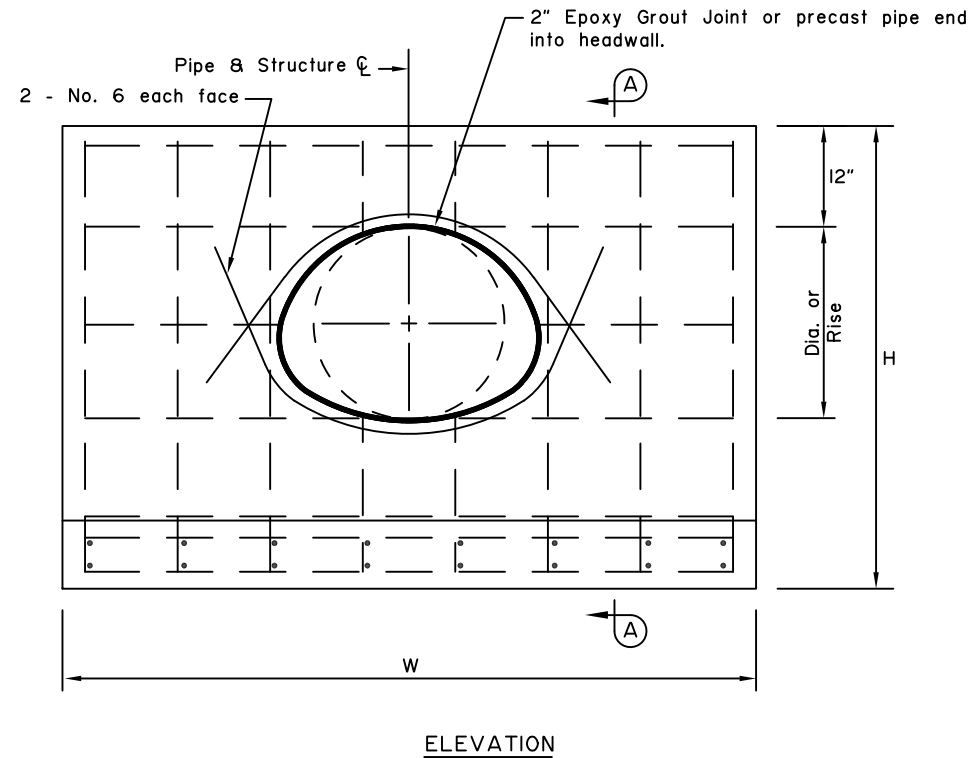

CORRUGATED METAL PIPE * SEE NOTE 8

Dia.	W	t _w	t _f	H	A1*	A2*	B	C	D1*	D2*	E
1'-6"	8'-0"	1'-0"	1'-0"	4'-6"	6'-0"	4'-0"	1'-6"	2'-0"	4'-0"	2'-0"	4'-0"
1'-9"	9'-0"	1'-0"	1'-0"	4'-9"	6'-6"	4'-0"	1'-6"	2'-0"	4'-6"	2'-0"	4'-3"
2'-0"	9'-6"	1'-0"	1'-0"	5'-0"	7'-0"	4'-0"	1'-6"	2'-0"	5'-0"	2'-0"	4'-6"
2'-6"	11'-6"	1'-0"	1'-0"	5'-6"	7'-6"	4'-0"	1'-6"	2'-0"	5'-6"	2'-0"	5'-0"
3'-0"	13'-0"	1'-0"	1'-0"	6'-0"	8'-6"	4'-6"	1'-6"	2'-0"	6'-6"	2'-6"	5'-6"
3'-6"	14'-6"	1'-0"	1'-0"	6'-6"	9'-0"	5'-0"	1'-6"	2'-0"	7'-0"	3'-0"	6'-0"
4'-0"	16'-0"	1'-0"	1'-0"	7'-0"	10'-0"	5'-6"	2'-0"	2'-6"	7'-6"	3'-0"	6'-6"
4'-6"	18'-0"	1'-3"	1'-3"	7'-9"	11'-0"	6'-0"	2'-0"	2'-9"	8'-6"	3'-6"	7'-3"
5'-0"	19'-6"	1'-6"	1'-6"	8'-6"	12'-0"	6'-6"	2'-6"	3'-6"	9'-0"	3'-6"	8'-0"

CORRUGATED METAL PIPE ARCH * SEE NOTE 8

SPAN	RISE	W	t _w	t _f	H	A1*	A2*	B	C	D1*	D2*	E
1'-5"	1'-1"	6'-6"	1'-0"	1'-0"	4'-1"	5'-6"	4'-0"	1'-6"	2'-0"	3'-6"	2'-0"	3'-7"
1'-9"	1'-3"	7'-0"	1'-0"	1'-0"	4'-3"	5'-6"	4'-0"	1'-6"	2'-0"	3'-6"	2'-0"	3'-9"
2'-0"	1'-6"	8'-0"	1'-0"	1'-0"	4'-6"	6'-0"	4'-0"	1'-6"	2'-0"	4'-0"	2'-0"	4'-0"
2'-4"	1'-8"	8'-6"	1'-0"	1'-0"	4'-8"	6'-0"	4'-0"	1'-6"	2'-0"	4'-0"	2'-0"	4'-2"
2'-11"	2'-0"	9'-6"	1'-0"	1'-0"	5'-0"	7'-0"	4'-0"	1'-6"	2'-0"	5'-0"	2'-0"	4'-6"
3'-6"	2'-5"	11'-0"	1'-0"	1'-0"	5'-5"	7'-6"	4'-0"	1'-6"	2'-0"	5'-6"	2'-0"	4'-11"
4'-1"	2'-9"	12'-0"	1'-0"	1'-0"	5'-9"	8'-0"	4'-0"	1'-6"	2'-0"	6'-0"	2'-6"	5'-3"
4'-9"	3'-2"	13'-6"	1'-0"	1'-0"	6'-2"	8'-6"	4'-0"	1'-6"	2'-0"	6'-6"	2'-6"	5'-8"
5'-4"	3'-7"	15'-0"	1'-0"	1'-0"	6'-7"	9'-0"	5'-0"	1'-6"	2'-0"	7'-0"	3'-0"	6'-1"
5'-11"	3'-11"	16'-0"	1'-0"	1'-0"	6'-11"	10'-0"	5'-6"	2'-0"	2'-6"	7'-6"	3'-0"	6'-5"
6'-5"	4'-4"	17'-0"	1'-3"	1'-3"	7'-7"	10'-6"	5'-6"	2'-0"	2'-9"	8'-0"	3'-0"	7'-1"
7'-1"	4'-9"	19'-0"	1'-6"	1'-6"	8'-3"	11'-6"	6'-6"	2'-6"	3'-6"	8'-6"	3'-6"	7'-9"

GENERAL NOTES:

- For use on 2:1 or flatter backfill slopes only.
- Use Class A concrete.
- Use epoxy-coated ASTM A706, Grade 60 reinforcing steel $f_y=60,000$ psi.
- Place reinforcement 3" clear from surface of concrete unless otherwise noted.
- Chamfer all exposed concrete corners 3/4".
- If unsuitable foundation material is encountered, remove and backfill with Foundation Fill as directed by the Engineer.
- Headwalls for skewed culverts to be parallel to road centerline. See plans for dimensions of openings in headwalls for skewed culverts.
- For backfill soil with:
 $\phi=30^\circ, \gamma=130$ pcf
 Use A1 and D1
 $\phi=34^\circ, \gamma=135$ pcf
 Use A2 and D2
- See plans for railing requirements.

State of Alaska DOT&PF
ALASKA STANDARD PLAN

HEADWALLS
PRECAST
TYPE II

Adopted as an Alaska
Standard Plan by: *Kenneth J. Fisher*
Kenneth J. Fisher, P.E.
Chief Engineer

Adoption Date: 02/08/2019

Last Code and Stds. Review
By: Date:

Next Code and Standards Review date: 02/08/2029

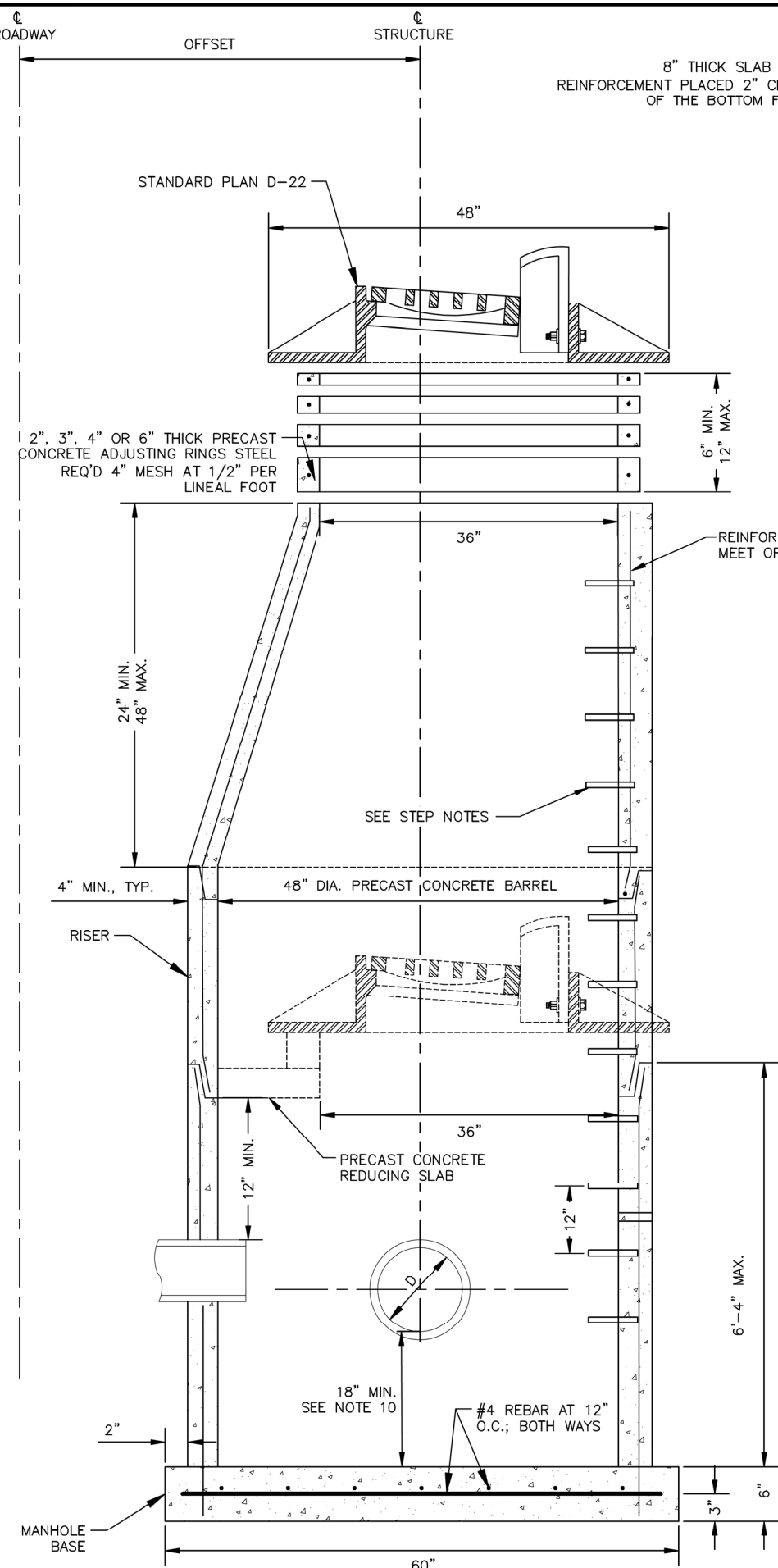

PRECAST CONCRETE REDUCING SLAB (48" TO 36")
N.T.S.

MANHOLE STEP NOTES:

1. MEET CURRENT OSHA STANDARDS FOR STEPS AND ACCESS OPENINGS.
2. PLACE STEPS 12" O.C. ON AN UNOBSTRUCTED SIDE OF THE STRUCTURE, 18" MAXIMUM FROM MANHOLE BASE. IF UNOBSTRUCTED SIDE NOT AVAILABLE, PLACE BOTTOM STEP 6" OVER SMALLEST PIPE. WHEN USING A CONE, FIRST LADDER RUNG IS 8" MAXIMUM FROM TOP OF CONE. WHEN USING A FLAT LID, FIRST LADDER RUNG IS 4" MAXIMUM FROM TOP OF RISER.
3. PROVIDE INJECTION MOLDED POLYPROPYLENE COVERED GRADE 60 STEEL STEPS TIGHTLY IMBEDDED AT LEAST 3" INTO CONCRETE.
4. INSTALL STEPS TO RESIST A PULLOUT FORCE OF 1500 LB.
5. THE MINIMUM DIAMETER OF CLEAR ACCESS TO STEPS IS 24".
6. THE CONTRACTOR SHALL TAKE SPECIAL CARE FOR ANY MANHOLE THAT FALLS IN A CURB LINE TO SEE THAT WHEN MANHOLE IS OFFSET DURING INSTALLATION THAT THE STEPS FALL UNDER THE CURB INLET.

GENERAL NOTES:

1. THESE DRAWINGS ARE FOR PRECAST REINFORCED CONCRETE FOR HIGHWAY USE. CAST IN PLACE STRUCTURES MAY BE USED AS APPROVED BY THE ENGINEER.
2. MEET THE REQUIREMENTS OF ASTM C-478 FOR ALL DRAINAGE STRUCTURES AND APPURTENANCES.
3. MINIMUM STEEL REQUIRED FOR BARREL AS PER ASTM C-478 SHALL BE IMBEDDED IN BASE SO THAT THE FIRST BARREL SECTION IS CONNECTED TO THE BASE BY CONTINUOUS STEEL. PROVIDE REINFORCING STEEL TYPE AND GRADE PER DOT&PF STANDARD SPECIFICATIONS.
4. USE CLASS A OR CLASS B CONCRETE PER DOT&PF STANDARD SPECIFICATIONS.
5. SEAL RISER JOINTS WITH FLEXIBLE PLASTIC JOINT SEALERS.
6. PROVIDE NON-SHRINK GROUT. PROTECT GROUT DURING CURE IN ACCORDANCE WITH THE MANUFACTURER'S RECOMMENDED METHOD.
7. FORM ALL BLOCK-OUTS.
8. MANHOLE SHALL HAVE A MINIMUM OF ONE 6" GRADE RING.
9. ALL STORM DRAIN MANHOLES AND INLETS SHALL HAVE 18" MINIMUM SUMPS. MANHOLES WITH PETROLEUM SEPARATORS SHALL HAVE 24" MINIMUM SUMPS.
10. OFFSET IS MEASURED TO CENTERLINE OF STRUCTURE.
11. EXTEND PIPE 2" INTO MANHOLE. SEAL PIPE PENETRATIONS WITH NON-SHRINKABLE GROUT MIXED WITH POTABLE WATER PER MANUFACTURER'S RECOMMENDATIONS.
12. CATCH BASIN LEADS SHALL ENTER THE MANHOLE AT LEAST ONE PRIMARY LEAD DIAMETER ABOVE THE TOP OF THE PRIMARY LEAD UNLESS MINIMUM PIPE SLOPES CANNOT BE ACHIEVED.
13. MAXIMUM PIPE DIAMETER SHALL NOT EXCEED HALF OF THE STRUCTURE DIAMETER. PRIMARY LEADS MUST BE A MINIMUM OF 135 DEGREES APART.
14. USE 72" STORM DRAIN MANHOLE OR LARGER WHEN BOTH CATCH BASIN AND ACCESS FUNCTIONS ARE REQUIRED.
15. LIVE LOAD FOR DESIGN OF THE MANHOLE BARRELS, RISERS AND REDUCING SLABS IS AASHTO HL-93 (HS20 AND DESIGN TANDEM AXLE/WHEEL LOADS).
16. A FLAT LID WITH A SMALLER OPENING MAY ALSO BE USED IF CALLED FOR IN THE PLANS.

REDUCING SLAB NOTES:

1. SPACE ALL REBAR AT 6" CENTERS UNLESS OTHERWISE NOTED.
2. MAINTAIN A MINIMUM OF 1 1/2" OF CONCRETE COVER OVER ALL REBAR.
3. REINFORCING STEEL SHOWN IS A MINIMUM PER ASTM C478. PRECAST MFR TO COMPLETE AND SUBMIT SHOP DRAWINGS AND CALCULATIONS FOR ENGINEER'S REVIEW.

STORM DRAIN MANHOLE, TYPE I
N.T.S.

State of Alaska DOT&PF
ALASKA STANDARD PLAN
48" STORM DRAIN MANHOLE
(PRECAST CONCRETE)
TYPE I MANHOLE
Adopted as an Alaska
Standard Plan by: *LL*
Lauren Little, P.E.
Interim Chief Engineer
Adoption Date: 01/29/2024

Last Code and Stds. Review
By: BMM Date: 12/13/2023
Next Code and Standards Review Date: 12/13/2033

D-35.10

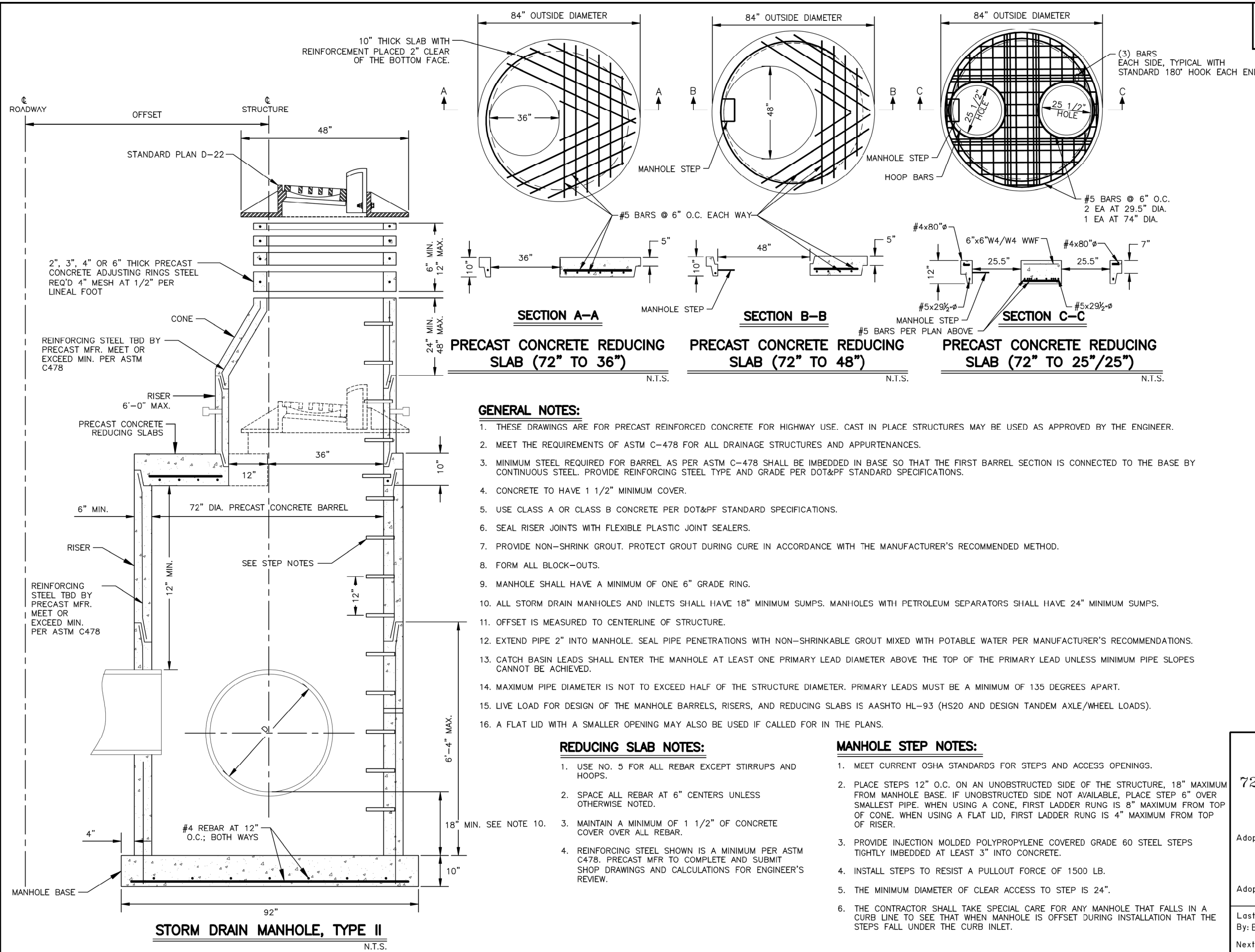

STORM DRAIN MANHOLE, TYPE II
N.T.S.

PRECAST CONCRETE REDUCING SLAB (72" TO 36")
N.T.S.

PRECAST CONCRETE REDUCING SLAB (72" TO 48")
N.T.S.

PRECAST CONCRETE REDUCING SLAB (72" TO 25"/25")
N.T.S.

GENERAL NOTES:

1. THESE DRAWINGS ARE FOR PRECAST REINFORCED CONCRETE FOR HIGHWAY USE. CAST IN PLACE STRUCTURES MAY BE USED AS APPROVED BY THE ENGINEER.
2. MEET THE REQUIREMENTS OF ASTM C-478 FOR ALL DRAINAGE STRUCTURES AND APPURTENANCES.
3. MINIMUM STEEL REQUIRED FOR BARREL AS PER ASTM C-478 SHALL BE IMBEDDED IN BASE SO THAT THE FIRST BARREL SECTION IS CONNECTED TO THE BASE BY CONTINUOUS STEEL. PROVIDE REINFORCING STEEL TYPE AND GRADE PER DOT&PF STANDARD SPECIFICATIONS.
4. CONCRETE TO HAVE 1 1/2" MINIMUM COVER.
5. USE CLASS A OR CLASS B CONCRETE PER DOT&PF STANDARD SPECIFICATIONS.
6. SEAL RISER JOINTS WITH FLEXIBLE PLASTIC JOINT SEALERS.
7. PROVIDE NON-SHRINK GROUT. PROTECT GROUT DURING CURE IN ACCORDANCE WITH THE MANUFACTURER'S RECOMMENDED METHOD.
8. FORM ALL BLOCK-OUTS.
9. MANHOLE SHALL HAVE A MINIMUM OF ONE 6" GRADE RING.
10. ALL STORM DRAIN MANHOLES AND INLETS SHALL HAVE 18" MINIMUM SUMPS. MANHOLES WITH PETROLEUM SEPARATORS SHALL HAVE 24" MINIMUM SUMPS.
11. OFFSET IS MEASURED TO CENTERLINE OF STRUCTURE.
12. EXTEND PIPE 2" INTO MANHOLE. SEAL PIPE PENETRATIONS WITH NON-SHRINKABLE GROUT MIXED WITH POTABLE WATER PER MANUFACTURER'S RECOMMENDATIONS.
13. CATCH BASIN LEADS SHALL ENTER THE MANHOLE AT LEAST ONE PRIMARY LEAD DIAMETER ABOVE THE TOP OF THE PRIMARY LEAD UNLESS MINIMUM PIPE SLOPES CANNOT BE ACHIEVED.
14. MAXIMUM PIPE DIAMETER IS NOT TO EXCEED HALF OF THE STRUCTURE DIAMETER. PRIMARY LEADS MUST BE A MINIMUM OF 135 DEGREES APART.
15. LIVE LOAD FOR DESIGN OF THE MANHOLE BARRELS, RISERS, AND REDUCING SLABS IS AASHTO HL-93 (HS20 AND DESIGN TANDEM AXLE/WHEEL LOADS).
16. A FLAT LID WITH A SMALLER OPENING MAY ALSO BE USED IF CALLED FOR IN THE PLANS.

REDUCING SLAB NOTES:

1. USE NO. 5 FOR ALL REBAR EXCEPT STIRRUPS AND HOOPS.
2. SPACE ALL REBAR AT 6" CENTERS UNLESS OTHERWISE NOTED.
3. MAINTAIN A MINIMUM OF 1 1/2" OF CONCRETE COVER OVER ALL REBAR.
4. REINFORCING STEEL SHOWN IS A MINIMUM PER ASTM C478. PRECAST MFR TO COMPLETE AND SUBMIT SHOP DRAWINGS AND CALCULATIONS FOR ENGINEER'S REVIEW.

MANHOLE STEP NOTES:

1. MEET CURRENT OSHA STANDARDS FOR STEPS AND ACCESS OPENINGS.
2. PLACE STEPS 12" O.C. ON AN UNOBSTRUCTED SIDE OF THE STRUCTURE, 18" MAXIMUM FROM MANHOLE BASE. IF UNOBSTRUCTED SIDE NOT AVAILABLE, PLACE STEP 6" OVER SMALLEST PIPE. WHEN USING A CONE, FIRST LADDER RUNG IS 8" MAXIMUM FROM TOP OF CONE. WHEN USING A FLAT LID, FIRST LADDER RUNG IS 4" MAXIMUM FROM TOP OF RISER.
3. PROVIDE INJECTION MOLDED POLYPROPYLENE COVERED GRADE 60 STEEL STEPS TIGHTLY IMBEDDED AT LEAST 3" INTO CONCRETE.
4. INSTALL STEPS TO RESIST A PULLOUT FORCE OF 1500 LB.
5. THE MINIMUM DIAMETER OF CLEAR ACCESS TO STEP IS 24".
6. THE CONTRACTOR SHALL TAKE SPECIAL CARE FOR ANY MANHOLE THAT FALLS IN A CURB LINE TO SEE THAT WHEN MANHOLE IS OFFSET DURING INSTALLATION THAT THE STEPS FALL UNDER THE CURB INLET.

State of Alaska DOT&PF
ALASKA STANDARD PLAN
72" STORM DRAIN MANHOLE (PRECAST CONCRETE)
TYPE II MANHOLE

Adopted as an Alaska Standard Plan by: 
Lauren Little, P.E.
Interim Chief Engineer

Adoption Date: 01/29/2024

Last Code and Stds. Review By: BMM Date: 12/13/2023
Next Code and Standards Review Date: 12/13/2033

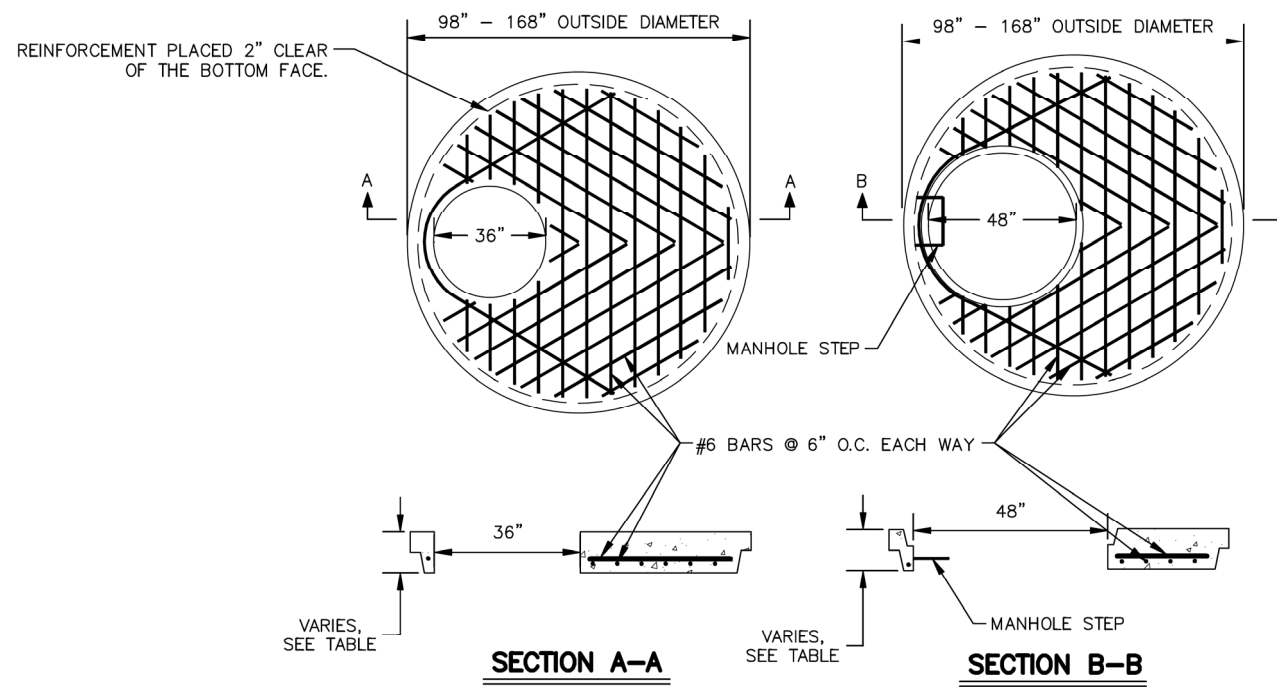
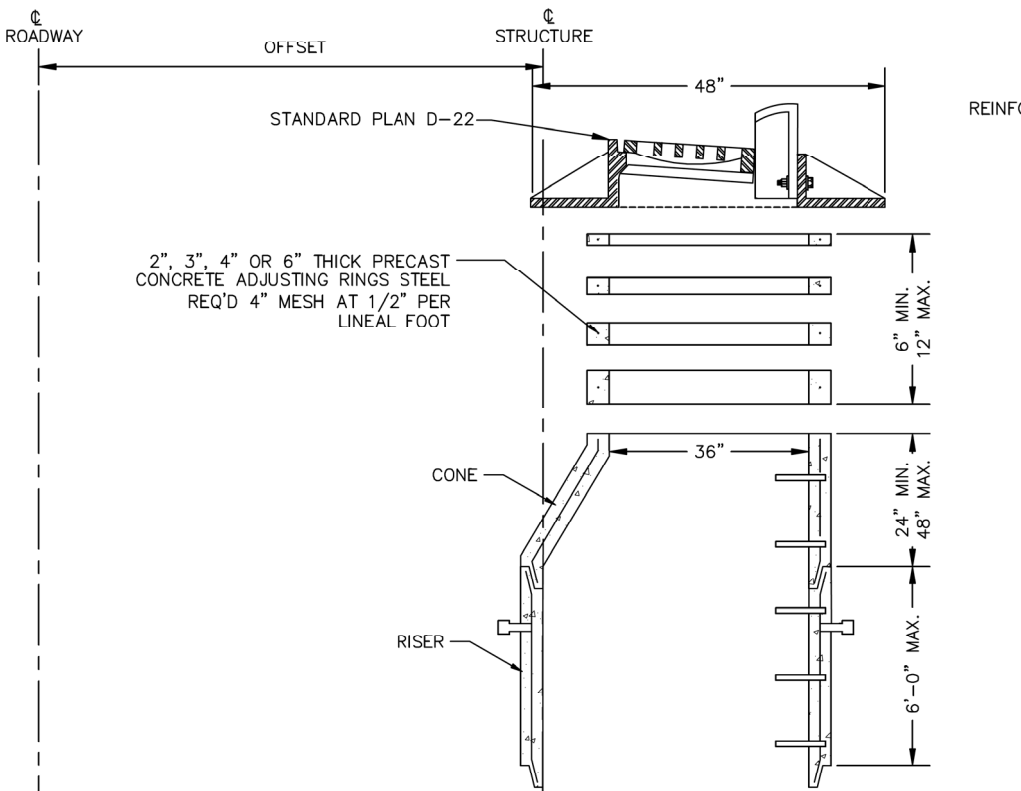

PRECAST CONCRETE REDUCING SLAB (84"-144" TO 36")
N.T.S.

PRECAST CONCRETE REDUCING SLAB (84"-144" TO 48")
N.T.S.

MANHOLE STEP NOTES:

1. MEET CURRENT OSHA STANDARDS FOR STEPS AND ACCESS OPENINGS.
2. STEPS SHALL BE PLACED 12" C.C. ON AN UNOBSTRUCTED SIDE OF THE STRUCTURE, 18" MAXIMUM FROM MANHOLE BASE. IF UNOBSTRUCTED SIDE NOT AVAILABLE, BOTTOM STEP TO BE PLACED 6" OVER SMALLEST PIPE. WHEN USING A CONE, FIRST LADDER RUNG IS 8" MAXIMUM FROM TOP OF CONE. WHEN USING A FLAT LID, FIRST LADDER RUNG IS 4" MAXIMUM FROM TOP OF RISER.
3. PROVIDE INJECTION MOLDED POLYPROPYLENE COVERED GRADE 60 STEEL STEPS TIGHTLY IMBEDDED AT LEAST 3" INTO CONCRETE.
4. INSTALL STEPS TO RESIST A PULLOUT FORCE OF 1500 LB.
5. THE MINIMUM DIAMETER OF CLEAR ACCESS TO STEP IS 24".
6. THE CONTRACTOR SHALL TAKE SPECIAL CARE FOR ANY MANHOLE THAT FALLS IN A CURB LINE TO SEE THAT WHEN MANHOLE IS OFFSET DURING INSTALLATION THAT THE STEPS FALL UNDER THE CURB INLET.

STRUCTURE TABLE				
MANHOLE I.D.	MIN. WALL THICKNESS	MIN. BASE THICKNESS	MIN. TOP SLAB THICKNESS	MIN. BASE PAD DIAMETER
84"	7"	12"	12"	104"
96"	8"	12"	12"	118"
108"	9"	14"	14"	132"
120"	10"	16"	14"	140"
132"	11"	16"	14"	154"
144"	12"	16"	14"	168"

REDUCING SLAB NOTES:

1. USE NO. 6 FOR ALL REBAR EXCEPT STIRRUPS AND HOOPS.
2. ALL REBAR SHALL BE SPACED AT 6" CENTERS UNLESS OTHERWISE NOTED.
3. MAINTAIN A MINIMUM OF 1 1/2" OF CONCRETE COVER OVER ALL REBAR.
4. REINFORCING STEEL SHOWN IS A MINIMUM PER ASTM C478. PRECAST MFR TO COMPLETE AND SUBMIT SHOP DRAWINGS AND CALCULATIONS FOR ENGINEER'S REVIEW.

GENERAL NOTES:

1. THESE DRAWINGS ARE FOR PRECAST REINFORCED CONCRETE FOR HIGHWAY USE. CAST IN PLACE STRUCTURES MAY BE USED AS APPROVED BY THE ENGINEER.
2. MEET THE REQUIREMENTS OF ASTM C-478 FOR ALL DRAINAGE STRUCTURES AND APPURTENANCES.
3. WHEN BASE PAD IS ATTACHED TO FIRST BARREL SECTION, MINIMUM STEEL REQUIRED FOR BARREL AS PER ASTM C-478 SHALL BE IMBEDDED IN BASE SO THAT THE FIRST BARREL SECTION IS CONNECTED TO THE BASE BY CONTINUOUS STEEL. PROVIDE REINFORCING STEEL TYPE AND GRADE PER DOT&PF STANDARD SPECIFICATIONS.
4. MINIMUM COVER ON REINFORCING STEEL IS 1" FOR CAST-IN-PLACE PRESTRESSED CONCRETE. ALL OTHER NON-PRESTRESSED CONCRETE TO HAVE 1 1/2" MIN. COVER.
5. USE CLASS A OR CLASS B CONCRETE PER DOT&PF STANDARD SPECIFICATIONS.
6. SEAL RISER JOINTS WITH FLEXIBLE PLASTIC JOINT SEALERS.
7. PROVIDE NON-SHRINK GROUT. PROTECT GROUT DURING CURE IN ACCORDANCE WITH THE MANUFACTURER'S RECOMMENDED METHOD.
8. FORM ALL BLOCK-OUTS.
9. MANHOLE SHALL HAVE A MINIMUM OF ONE 6" GRADE RING.
10. ALL STORM DRAIN MANHOLES AND INLETS SHALL HAVE 18" MINIMUM SUMPS. MANHOLES WITH PETROLEUM SEPARATORS SHALL HAVE 24" MINIMUM SUMPS.
11. OFFSET IS MEASURED TO CENTERLINE OF STRUCTURE.
12. EXTEND PIPE 2" INTO MANHOLE. SEAL PIPE PENETRATIONS WITH NON-SHRINKABLE GROUT MIXED WITH POTABLE WATER PER MANUFACTURES RECOMMENDATIONS.
13. CATCH BASIN LEADS SHALL ENTER THE MANHOLE AT LEAST ONE PRIMARY LEAD DIAMETER ABOVE THE TOP OF THE PRIMARY LEAD UNLESS MINIMUM PIPE SLOPES CANNOT BE ACHIEVED.
14. MAXIMUM PIPE DIAMETER IS NOT TO EXCEED HALF OF THE STRUCTURE DIAMETER. PRIMARY LEADS MUST BE A MINIMUM OF 135 DEGREES APART.
15. ALL PENETRATIONS REQUIRE ADDITIONAL #4 HOOP.
16. LIVE LOAD FOR DESIGN OF THE MANHOLE BARRELS, RISERS AND REDUCING SLABS IS AASHTO HL-93 (HS20 AND DESIGN TANDEM AXLE/WHEEL LOADS).
17. A FLAT LID WITH A SMALLER OPENING MAY ALSO BE USED IF CALLED FOR IN THE PLANS.

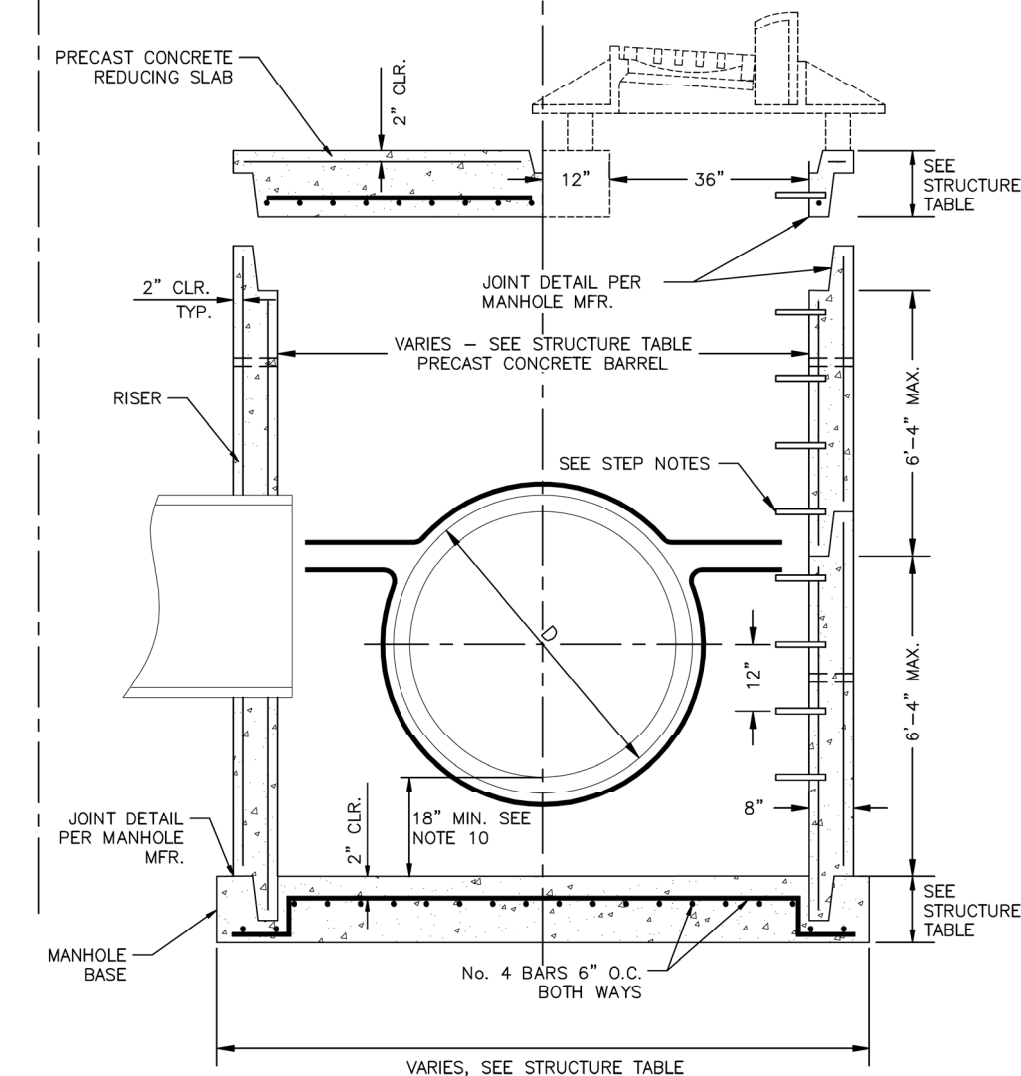

STORM DRAIN MANHOLE, TYPE III
N.T.S.

State of Alaska DOT&PF
ALASKA STANDARD PLAN
84" TO 144" STORM DRAIN
MANHOLE
(PRECAST CONCRETE)
TYPE III MANHOLE

Adopted as an Alaska
Standard Plan by:

Lauren Little, P.E.
Interim Chief Engineer

Adoption Date: 01/29/2024

Last Code and Stds. Review
By: BMM Date: 12/13/2023

Next Code and Standards Review Date: 12/13/2033

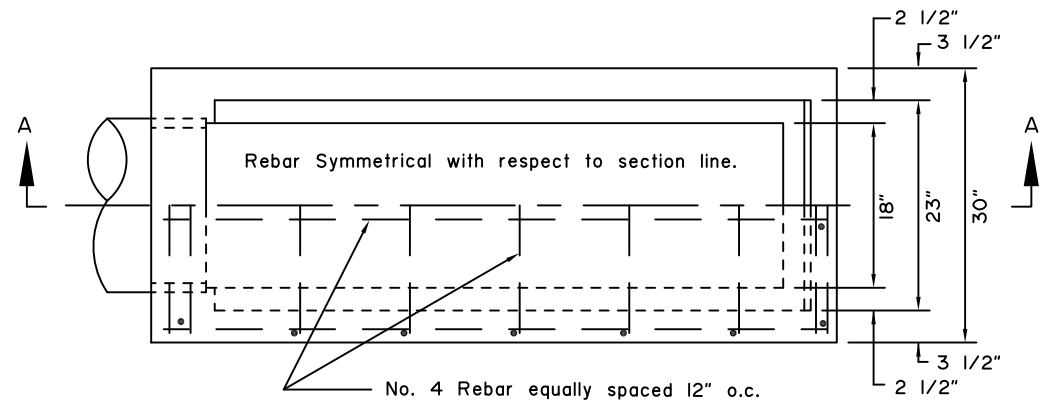

PLAN
(Frame not shown for clarity)

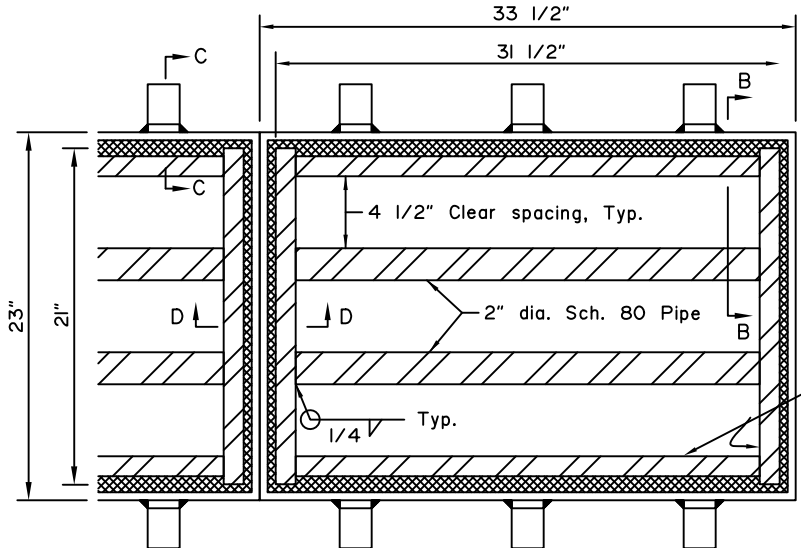

STEEL FRAME AND GRATE CONFIGURATION

GENERAL NOTES:

1. Provide either steel frames and grates or cast iron frames and grates.
2. Chamfer all exposed concrete corners 3/4".
3. Provide 2" minimum cover for all reinforcing steel.
4. Use Grade 40 minimum reinforcing steel.
5. Cast iron frame embedment lugs may differ from the configuration shown for the steel frame. Provide 6 total embedment lugs extending into concrete a minimum of 3".
6. Shop fabricate steel frames and steel grates.
7. Hot dip galvanize steel frames and grates. Provide uncoated cast iron frames and grates.

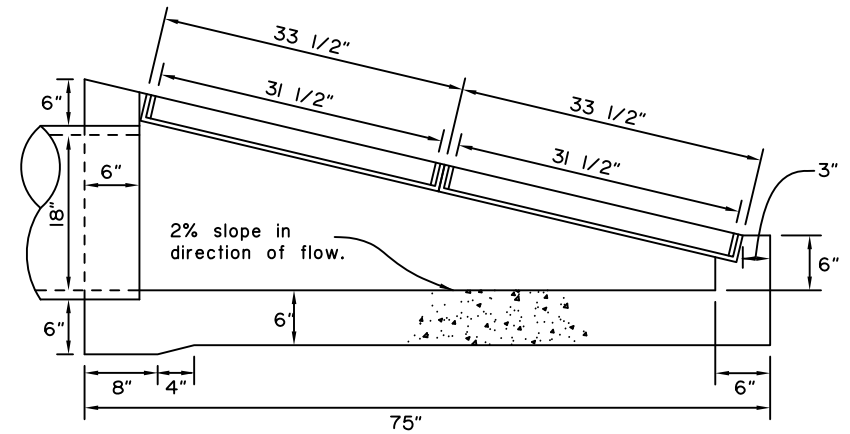

SECTION A-A

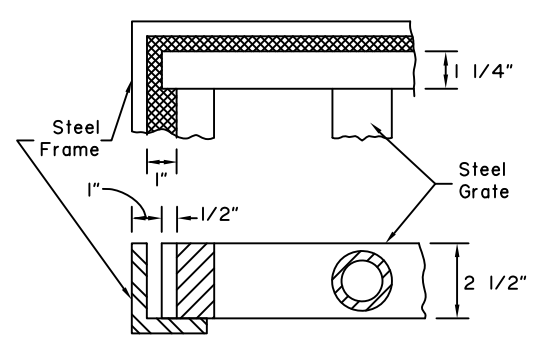

SECTION B-B

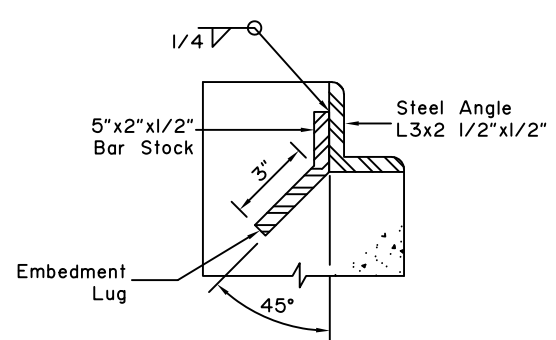

SECTION C-C

STEEL FRAME & GRATE DETAILS
Finished grate size is 21"x31 1/2"

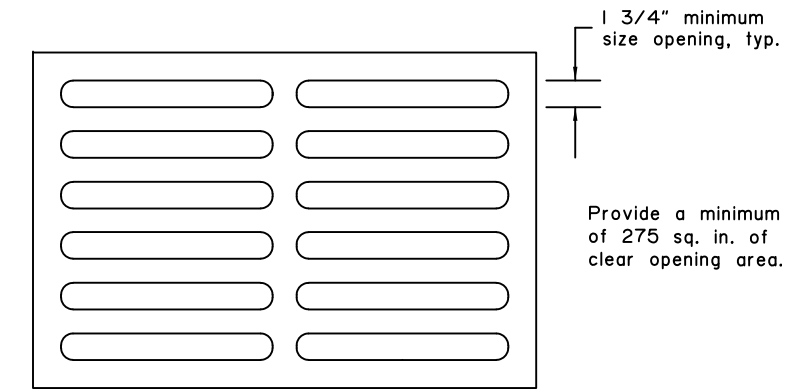

CAST IRON GRATE CONFIGURATION
Finished grate size is 21"x 31 1/2"

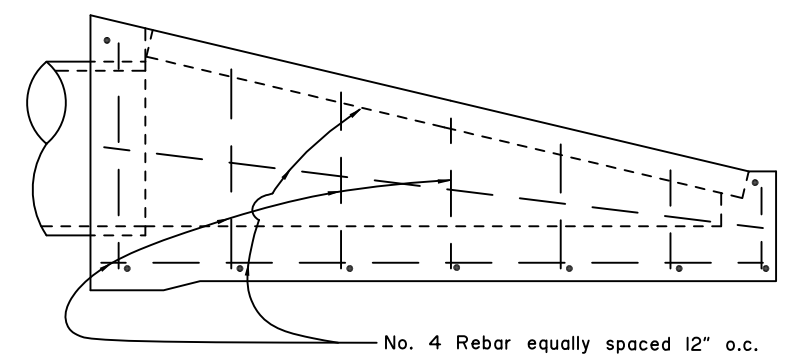

TYPICAL REINFORCEMENT STEEL DETAIL

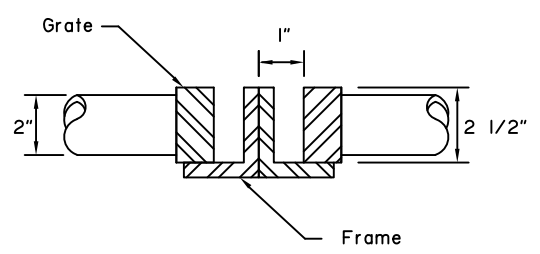

SECTION D-D

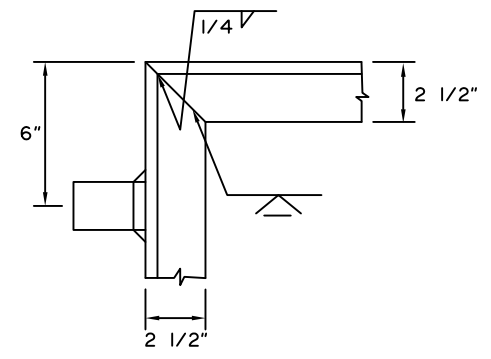

STEEL FRAME DETAIL

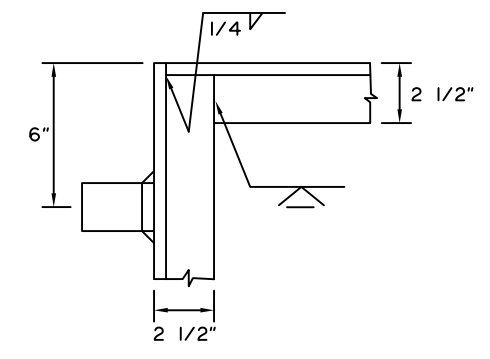

ALTERNATE STEEL FRAME DETAIL

NOTE: DRAWING NOT TO SCALE

State of Alaska DOT&PF
ALASKA STANDARD PLAN
TYPE "C" INLET BOX
18 INCH PIPE
ON 4:1 SLOPE

Adopted as an Alaska Standard Plan by: *Kenneth J. Fisher*
Kenneth J. Fisher, P.E.
Chief Engineer

Adoption Date: 02/08/2019

Last Code and Stds. Review By: _____ Date: _____

Next Code and Standards Review date: 02/08/2029

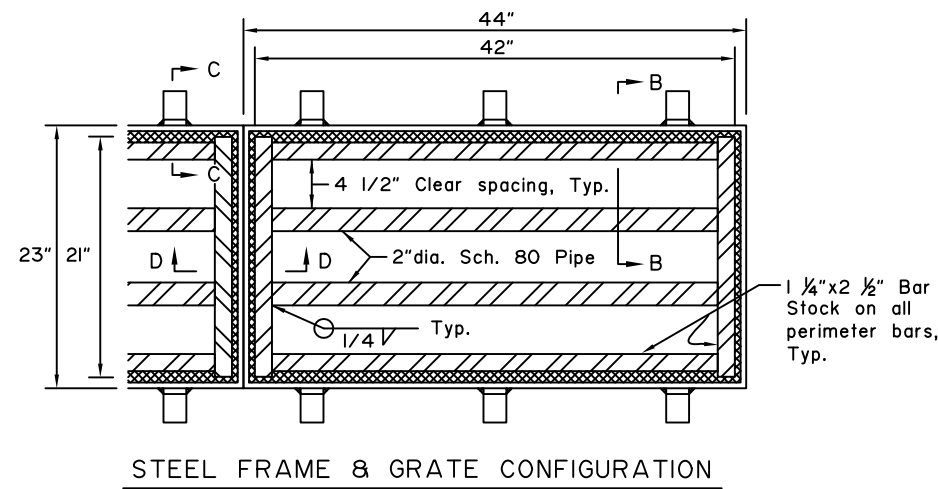
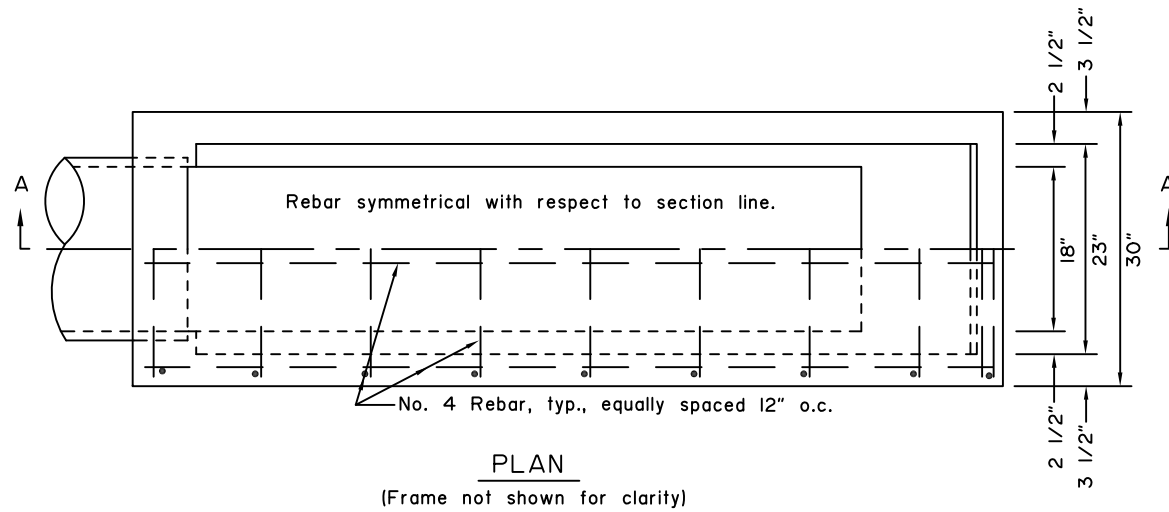

GENERAL NOTES:

1. Provide either steel frames and grates or cast iron frames and grates.
2. Chamfer all exposed concrete corners 3/4".
3. Provide 2" minimum cover for all reinforcing steel.
4. Use Grade 40 minimum reinforcing steel.
5. Cast iron frame embedment lugs may differ from the configuration shown for steel frames. Provide 6 total embedment lugs extending into concrete a minimum of 3".
6. Shop fabricate steel frames and steel grates.
7. Hot dip galvanize steel frames and grates. Provide uncoated cast iron frames and grates.

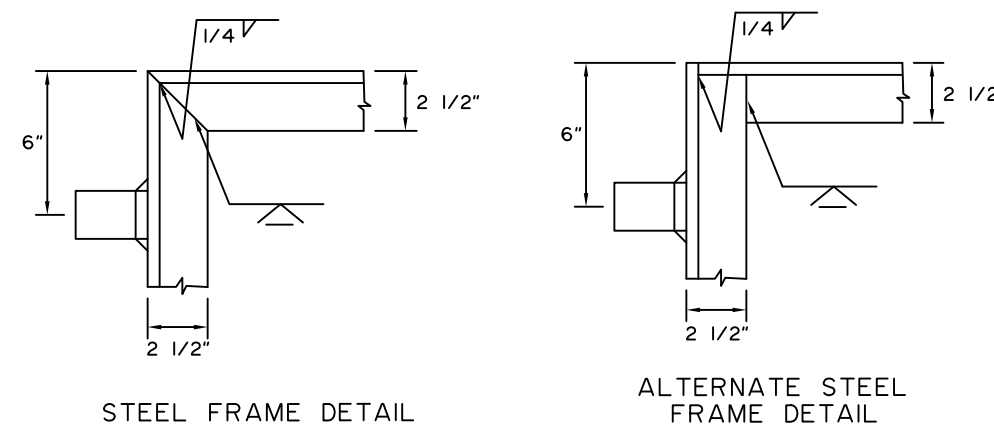
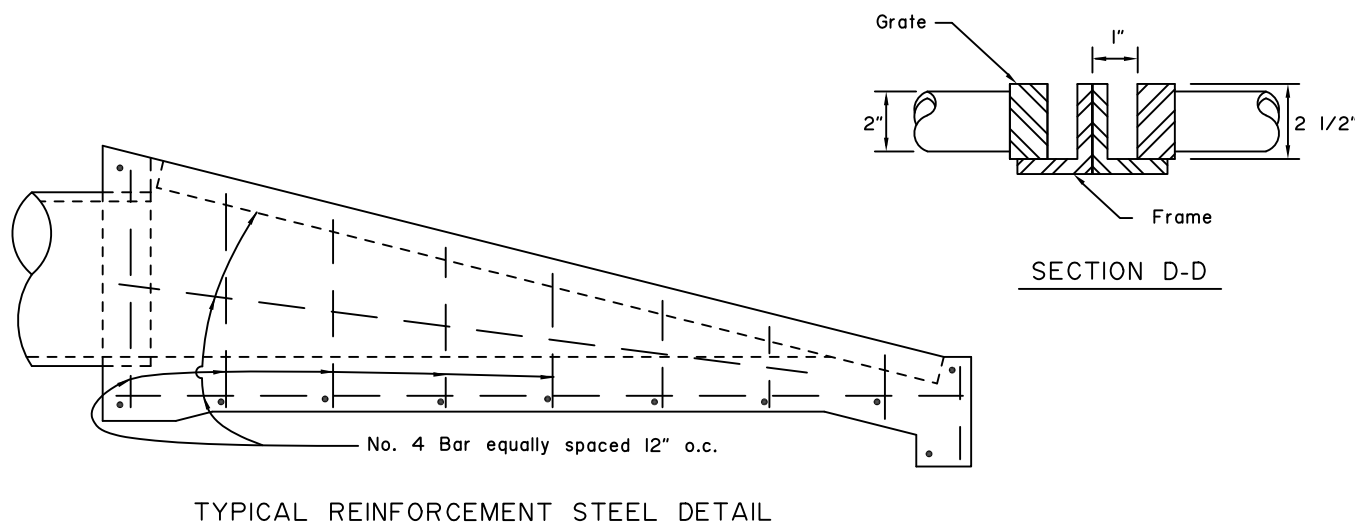
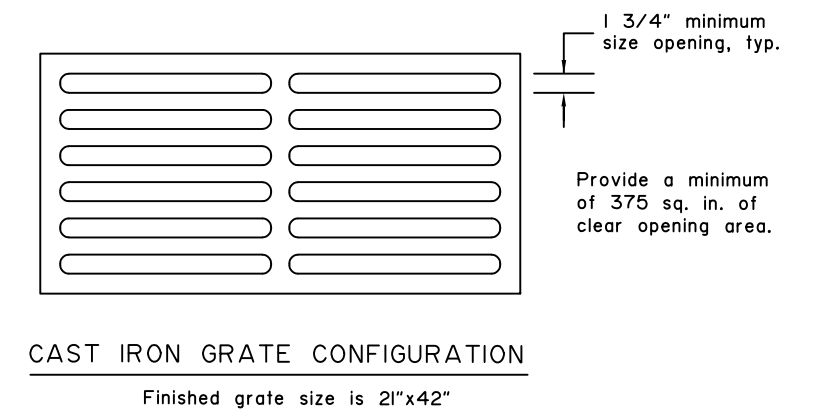
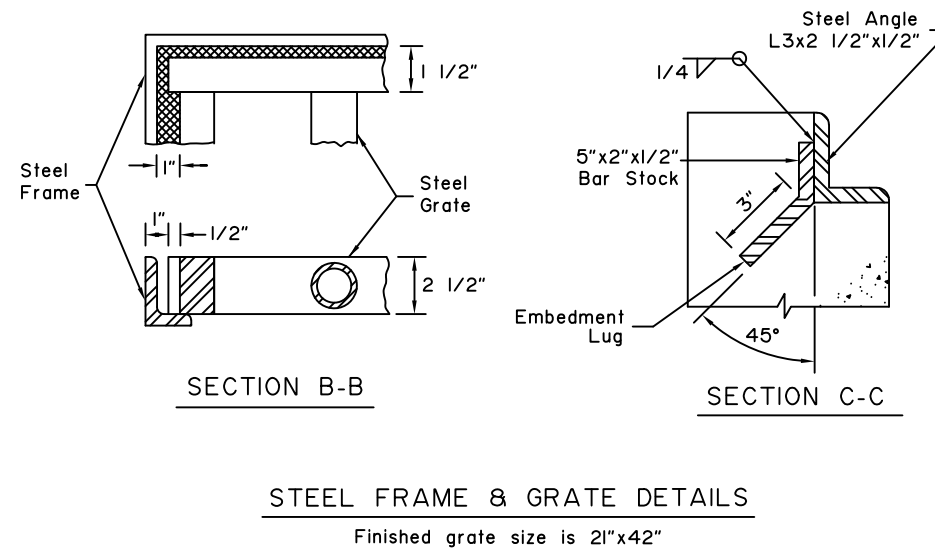
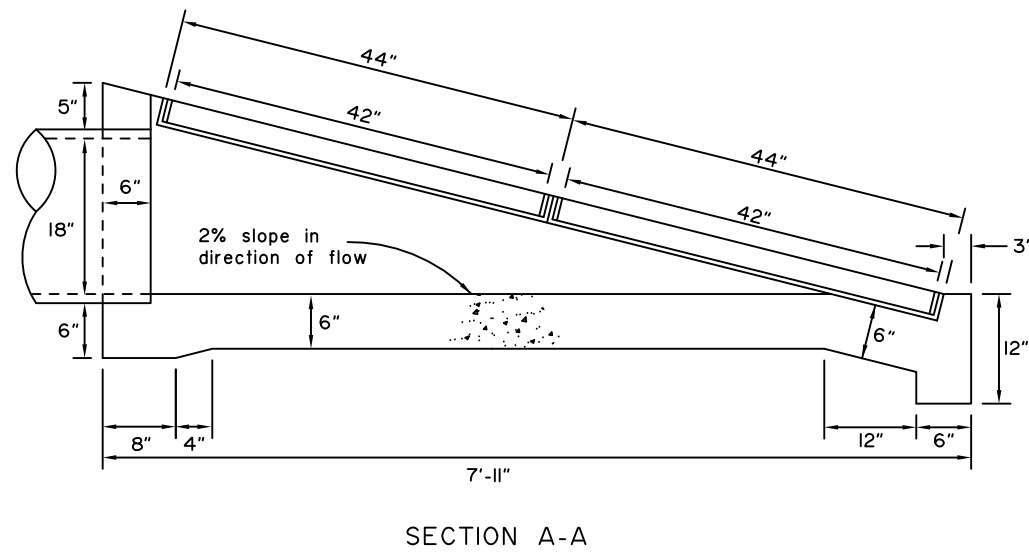

NOTE: DRAWING NOT TO SCALE

State of Alaska DOT&PF
ALASKA STANDARD PLAN
TYPE "D" OUTLET BOX
18 INCH PIPE
ON 4:1 SLOPE

Adopted as an Alaska Standard Plan by: *Kenneth J. Fisher*
Kenneth J. Fisher, P.E.
Chief Engineer

Adoption Date: 02/08/2019

Last Code and Stds. Review By: Date:

Next Code and Standards Review date: 02/08/2029

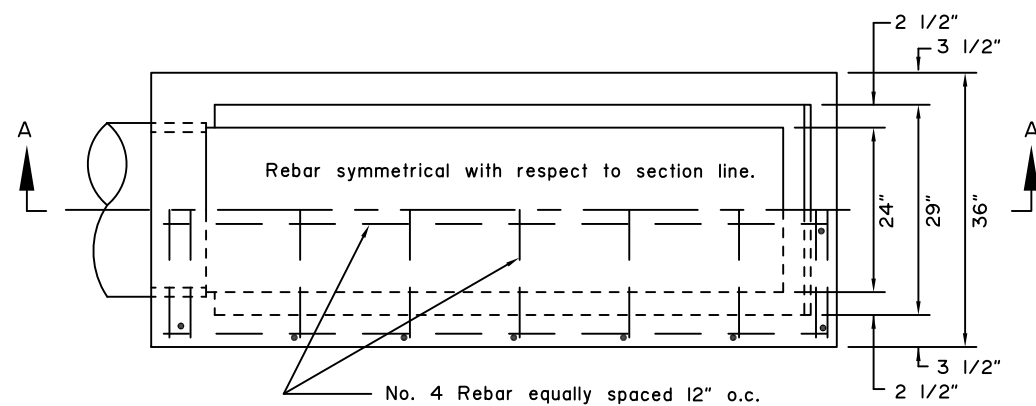

PLAN
(Grate not shown for clarity)

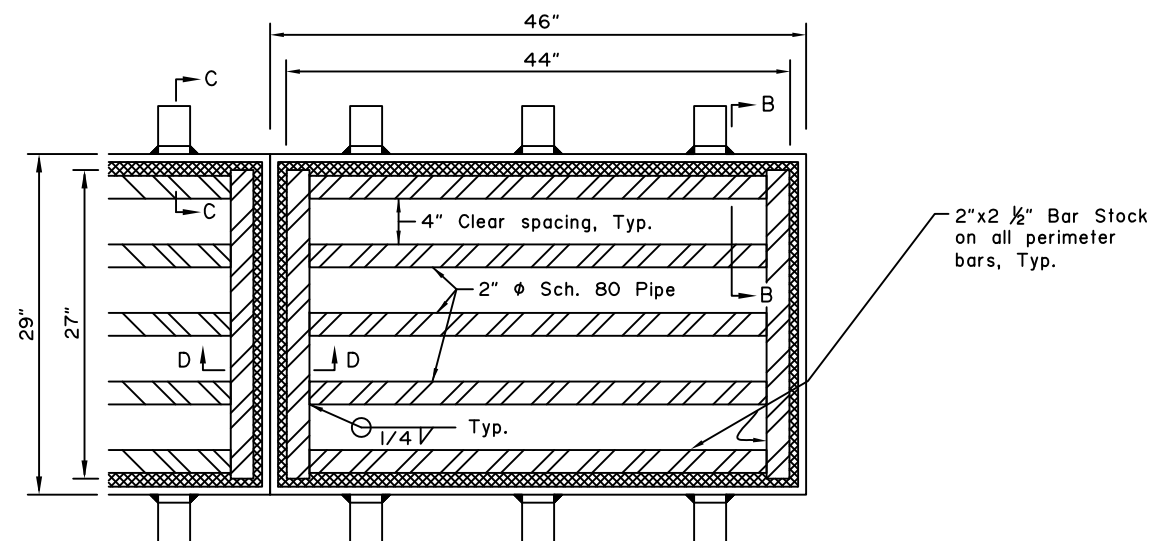

STEEL FRAME & GRATE CONFIGURATION

GENERAL NOTES:

1. Provide either steel frames and grates or cast iron frames and grates.
2. Chamfer all exposed concrete corners $\frac{3}{4}$ ".
3. Provide 2" minimum cover for all reinforcing steel.
4. Use Grade 40 minimum reinforcing steel.
5. Cast iron frame embedment lugs may differ from the configuration shown for steel frames. Provide 6 total embedment lugs extending into concrete a minimum of 3".
6. Shop fabricate steel frames and steel grates.
7. Hot dip galvanize steel frames and grates. Provide uncoated cast iron frames and grates.

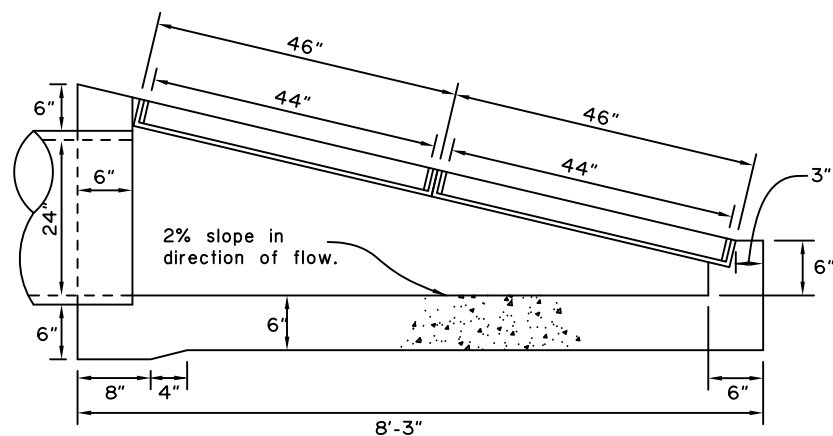

SECTION A-A

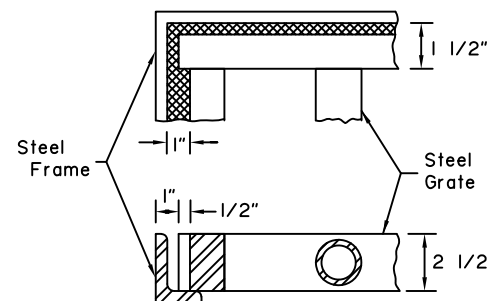

SECTION B-B

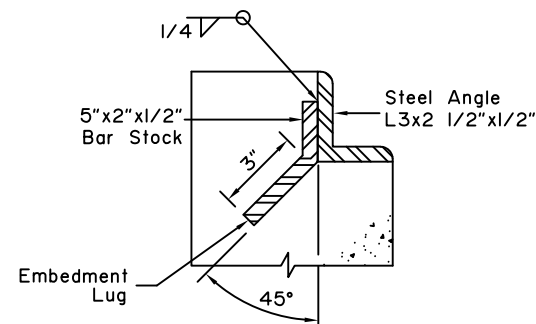

SECTION C-C

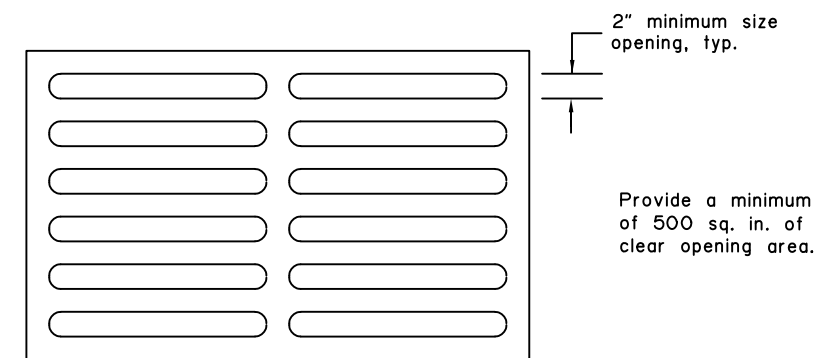

CAST IRON GRATE CONFIGURATION

STEEL FRAME & GRATE DETAILS

Finished grate size is 27"x44"

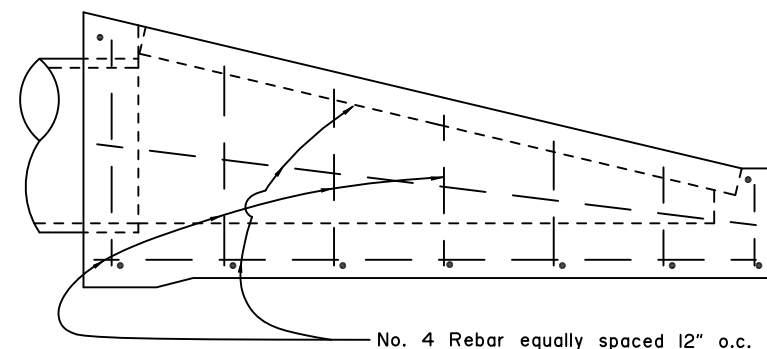

TYPICAL REINFORCEMENT STEEL DETAIL

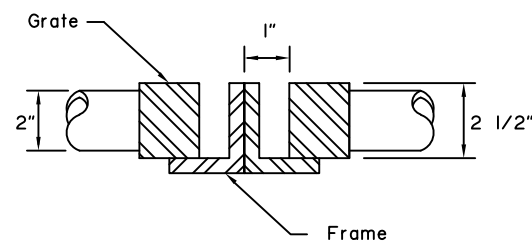

SECTION D-D

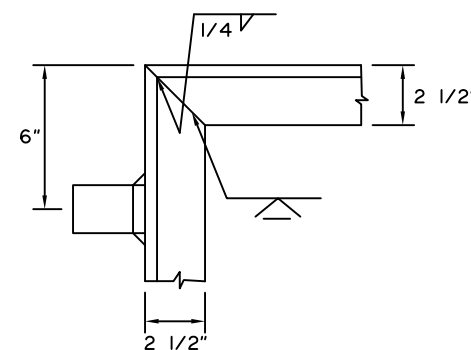

STEEL FRAME DETAIL

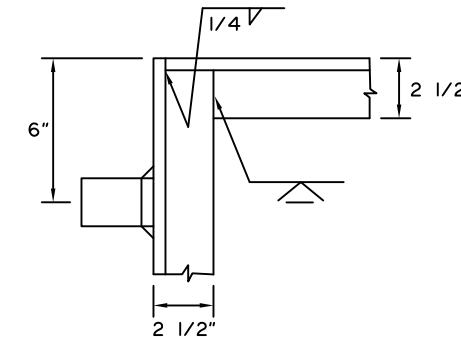

ALTERNATE STEEL FRAME DETAIL

NOTE: DRAWING NOT TO SCALE

State of Alaska DOT&PF
ALASKA STANDARD PLAN
TYPE "C" INLET BOX
24 INCH PIPE
ON 4:1 SLOPE

Adopted as an Alaska
Standard Plan by: *Kenneth J. Fisher*
Kenneth J. Fisher, P.E.
Chief Engineer

Adoption Date: 02/08/2019

Last Code and Stds. Review
By: Date:

Next Code and Standards Review date: 02/08/2029

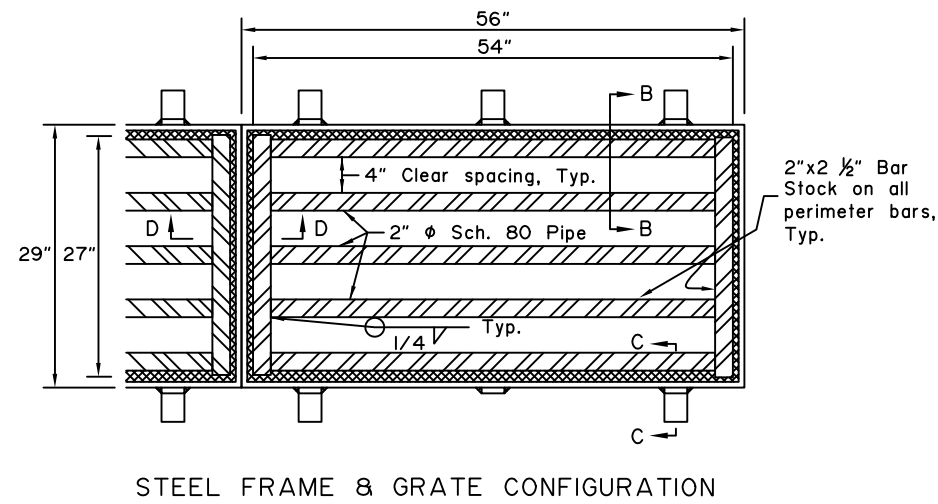
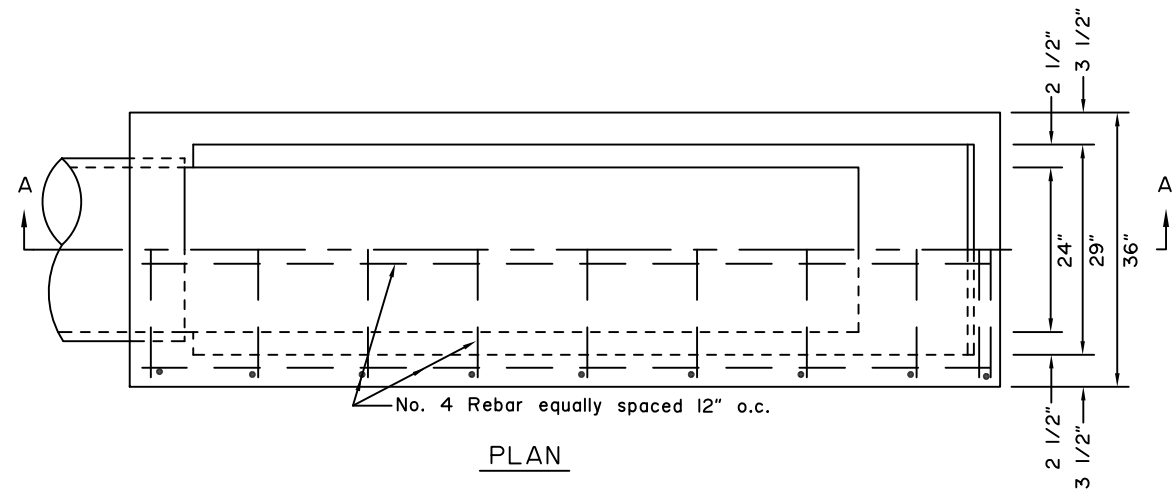

GENERAL NOTES:

1. Provide either steel frames and grates or cast iron frames and grates.
2. Chamfer all exposed concrete corners $\frac{3}{4}$ ".
3. Provide 2" minimum cover for all reinforcing steel.
4. Use Grade 40 minimum reinforcing steel.
5. Cast iron frame embedment lugs may differ from the configuration shown for steel frames. Provide 6 total embedment lugs extending into concrete a minimum of 3".
6. Shop fabricate steel frames and steel grates.
7. Hot dip galvanize steel frames and grates. Provide uncoated cast iron frames and grates.

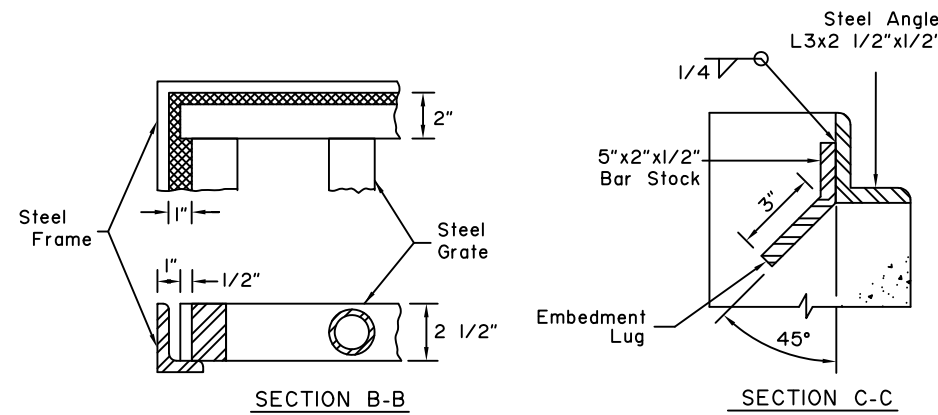
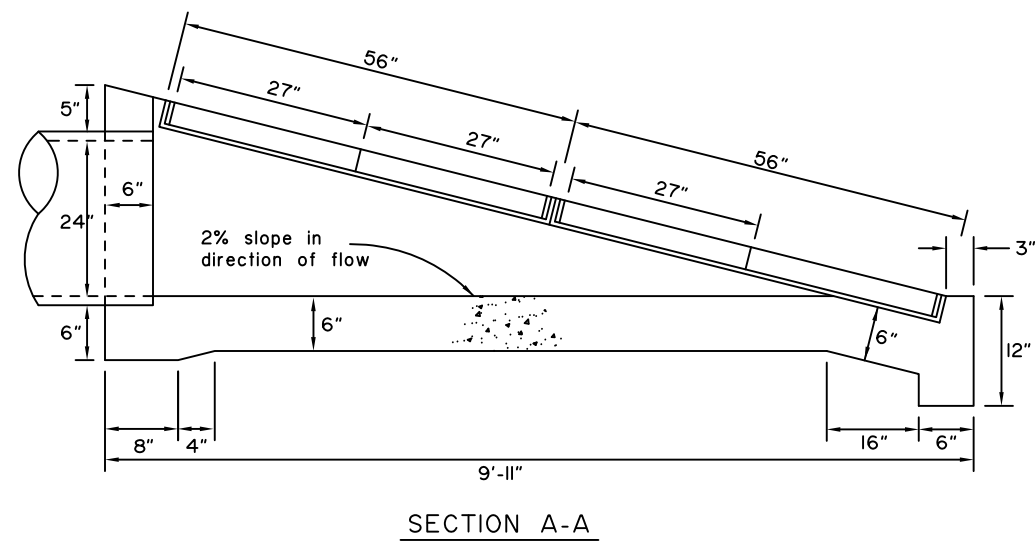

STEEL FRAME & GRATE DETAILS
Finished grate size is 27"x54"

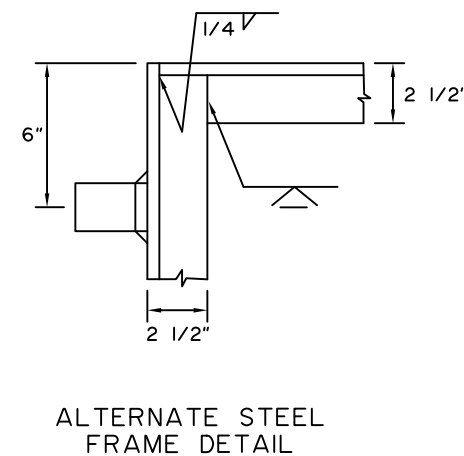
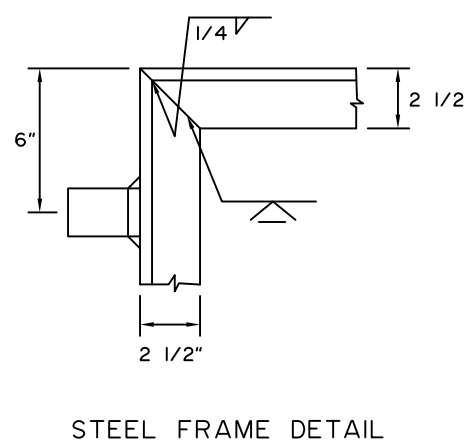
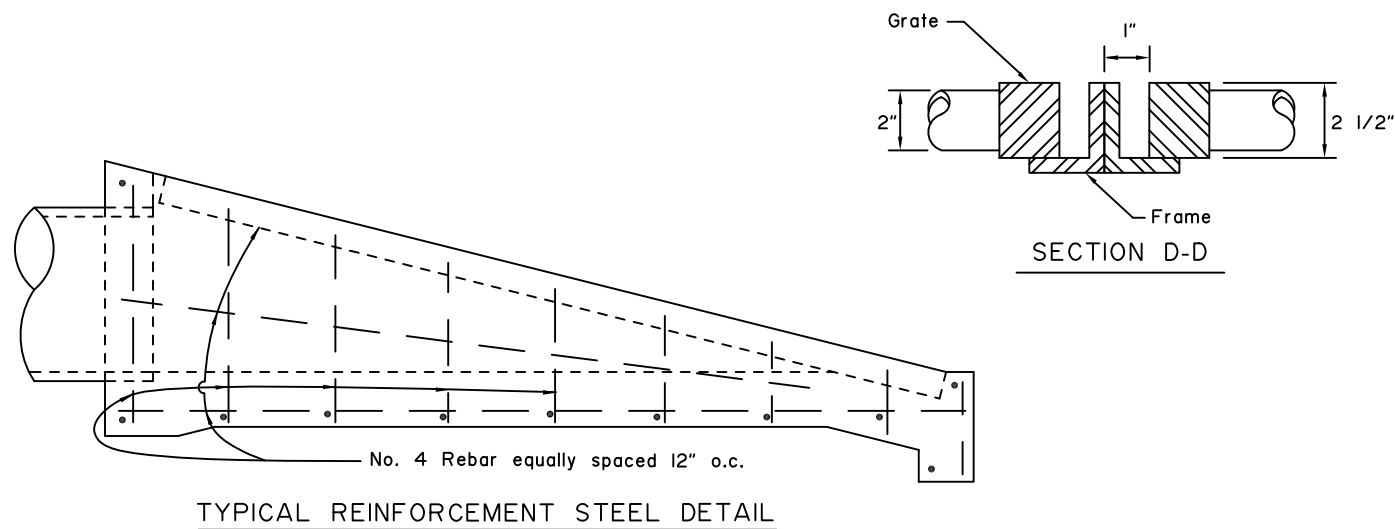
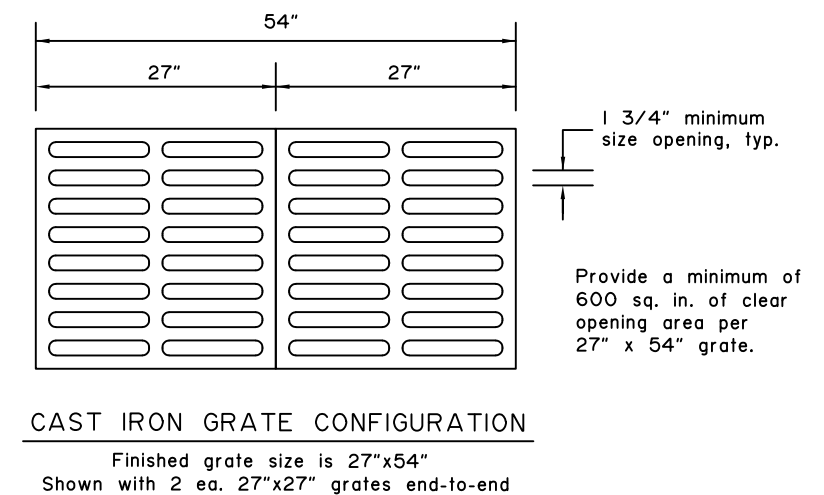

State of Alaska DOT&PF
ALASKA STANDARD PLAN
TYPE "D" OUTLET BOX
24 INCH PIPE
ON 4:1 SLOPE

Adopted as an Alaska Standard Plan by: *Kenneth J. Fisher*
Kenneth J. Fisher, P.E.
Chief Engineer

Adoption Date: 02/08/2019

Last Code and Stds. Review By: Date:

Next Code and Standards Review date: 02/08/2029

NOT TO SCALE

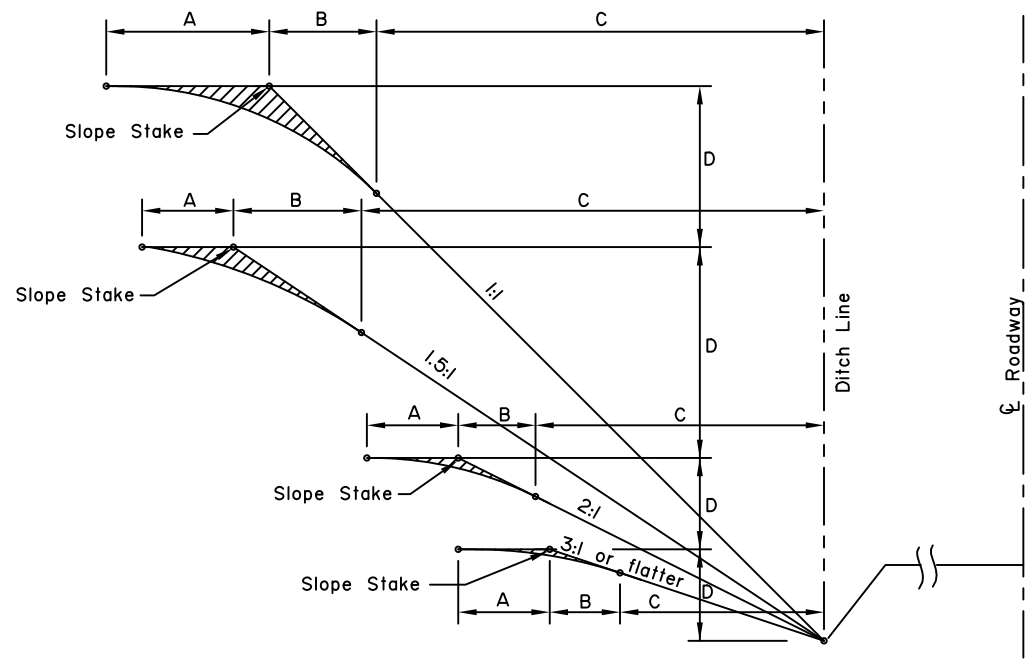

FIG. 1
TYPICAL SECTION OF ROUNDED SLOPES

TABLE OF ROUNING DIMENSIONS

Rate of Slope	A		B	
	When B's 5.0' or less	When B is more than 5.0'	When D's 15.0' or less	When D is more than 15.0'
3:1 or flatter	B	5.0'	5.0'	5.0'
2:1	B	5.0'	5.0'	D/3
1.5:1	B	5.0'	5.0'	D/3
1:1	B	$\frac{D}{3}$, Max. 10.0'		D/3

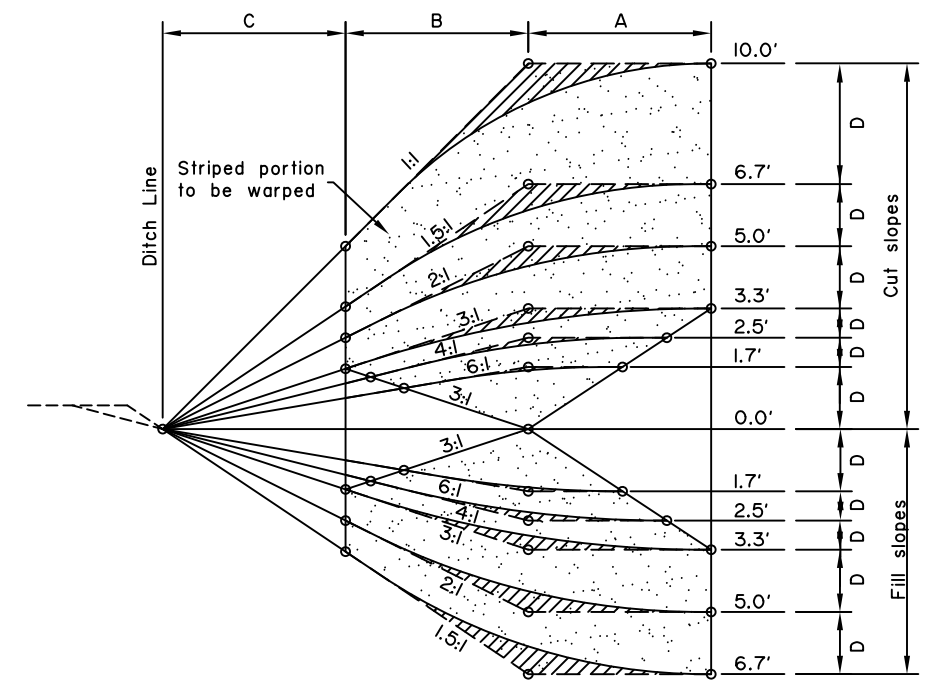

FIG. 4
TYPICAL GRADING FOR WARPING SLOPES

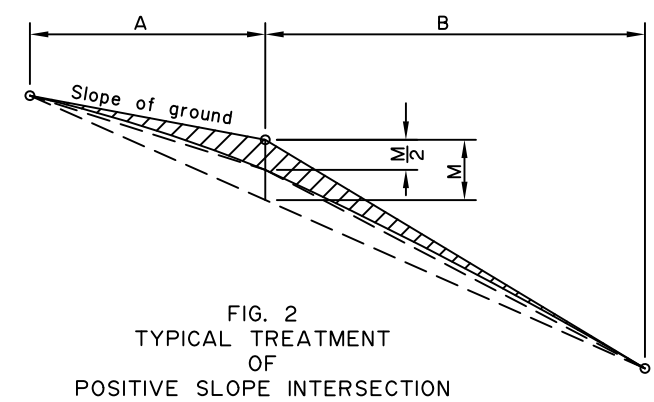

FIG. 2
TYPICAL TREATMENT OF POSITIVE SLOPE INTERSECTION

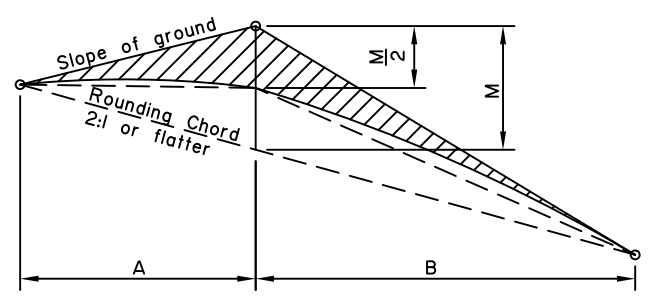

FIG. 3
TYPICAL TREATMENT OF NEGATIVE SLOPE INTERSECTION

TYPICAL SLOPE ROUNING

GENERAL NOTES

1. Cut and fill slopes shall be rounded as shown in fig. 1, 2, and 3 when required by the plans or special provisions. Rounding of fill slopes shall be done in the same manner as shown for cut slopes.
2. Intersections of cut and fill slopes shall be warped as shown in fig. 4 and 5 when required by the plans or special provisions.
3. Warping of cut and fill slopes is for the purpose of attaining a more pleasing appearance and to promote the growth of natural vegetation by causing the fill slope to flow smoothly into the cut slope. The length of slope warping is relatively proportional to the character of the topography, the distance between end limits of warped surfaces being lessened as the terrain steepens and lengthened as the topography flattens out. The procedure as outlined herein is typical and shall be varied to meet special conditions and shall be as staked by the Engineer.
4. SUGGESTED PROCEDURE FOR WARPING SLOPING
 - A--Select end points for warping to fit specified slope ratios as follows:-
 - (a) The dimensions A, B, and C shall all be constant throughout the full length of warping, E.
 - (b) When the average depth of cut or fill is such that the dimension B+C exceeds 10 feet, the ends of warping shall be at points where B+C is 10 feet, provided the warping distance E does not exceed 100 feet. That is, as shown in fig. 4 and 5, warping shall begin at a cut or fill depth of 6.7 feet for 1.5:1 slopes, at 50 feet for 2:1 slopes, etc. if the dimension E exceeds 100 feet, the dimension B+C shall be reduced until the intersections of the prescribed slopes with the natural ground are 100 feet apart.
 - (c) When the average depth of cut or fill is such that the distance B+C is between 5 feet and 10 feet, the ends of warping shall be at points where C is 0 feet, but such points shall not be more than 150 feet apart.
 - (d) When the average depth of cut or fill is such that the dimension B is less than 5 feet, the ends of warping shall be 200 feet apart.
 - B--Set slope stakes at end of warping.
 - C--Set additional slope stakes at various intervals between end stakes and at the same distance from centerline.
 - D--Flatten and round warped slopes as shown in figure 4 for each section.
5. A layer of earth overlying a rock cut shall be rounded as far as possible as though the total height of slope were in earth cut.

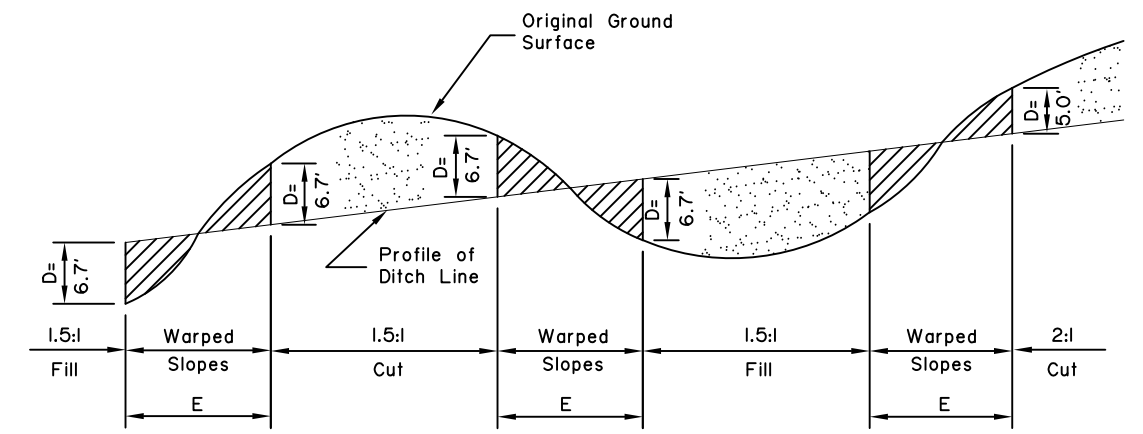

FIG. 5
TYPICAL PROFILE OF WARPED SLOPES

TYPICAL SLOPE WARPING

State of Alaska DOT&PF
ALASKA STANDARD PLAN

SLOPE ROUNING AND WARPING

Adopted as an Alaska Standard Plan by: *Kenneth J. Fisher*
Kenneth J. Fisher, P.E.
Chief Engineer

Adoption Date: 02/08/2019

Last Code and Stds. Review By: Date: _____

Next Code and Standards Review date: 02/08/2029

NOTE: Pull post shall be spaced at 250' maximum intervals.

Fabric shall be placed on highway side of post.

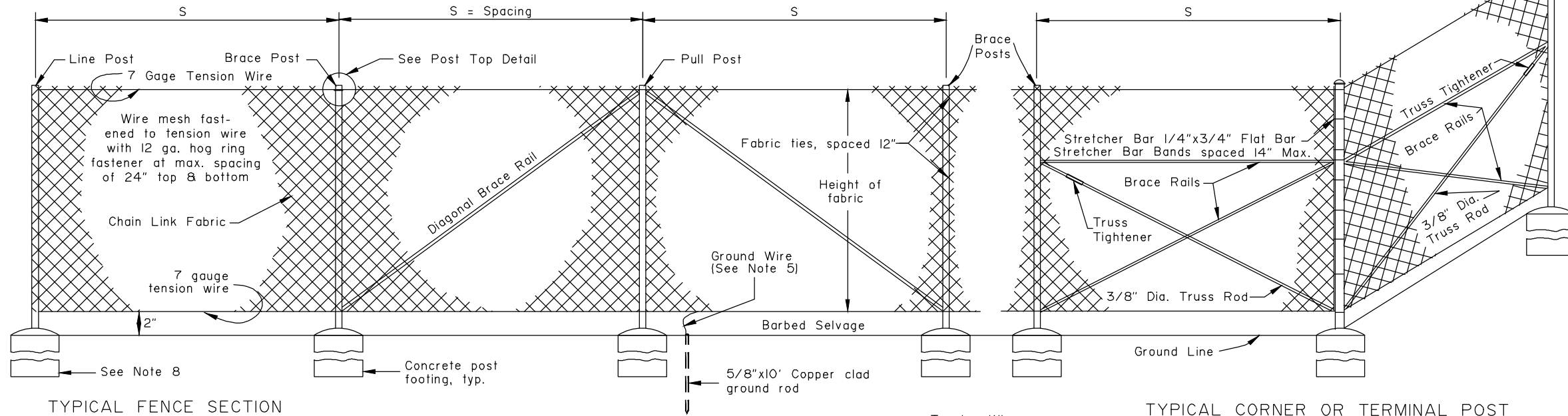

GENERAL NOTES:

1. Use equal pole spacing (S). Maximum pole spacing is 10 feet unless directed otherwise by the Engineer.
2. Securely fasten post tops to post.
3. Securely fasten brace rails and truss rods to post with brace bands.
4. Provide truss rods with a tensioning adjusting mechanism.
5. Attach ground wire to fence fabric with a split bolt.
6. Stretch fabric to a smooth uniform appearance.
7. Details shown indicate general design and dimensions may vary among manufacturers.
8. Set line, pull, corner, and terminal posts in concrete footings unless in muskeg or shown otherwise in the plans.

TYPICAL FENCE SECTION

TYPICAL PULL POST

TYPICAL CORNER OR TERMINAL POST

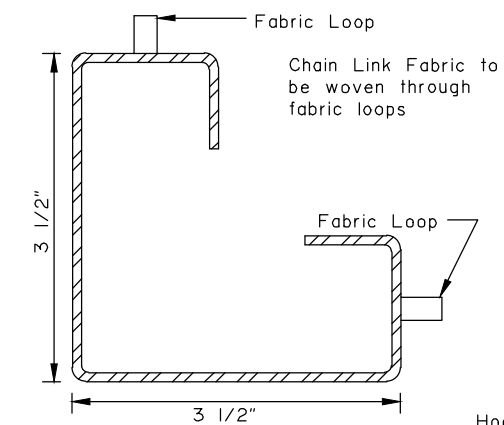

ROLL FORMED POST

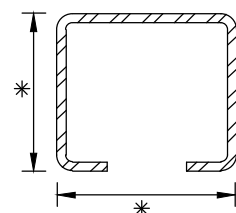

C POST

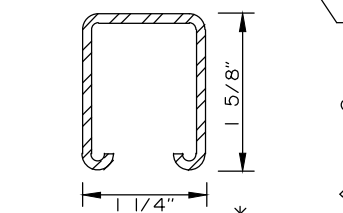

ROLL FORMED
BRACE

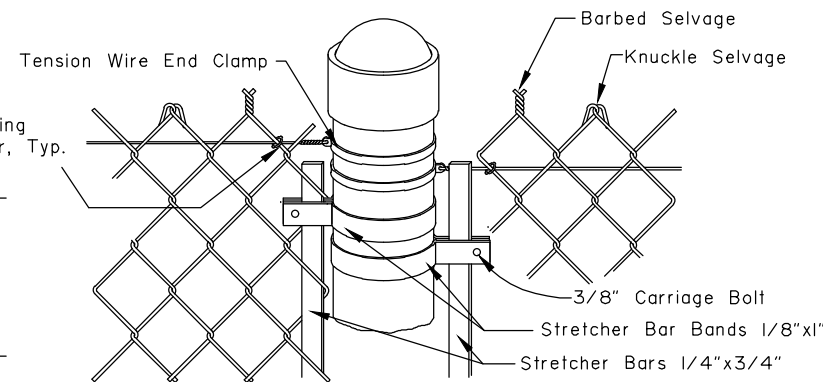

PIPE STYLE POST TOP

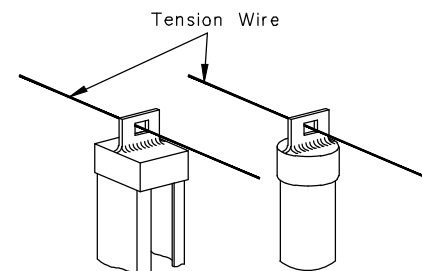

LINE POST TOPS

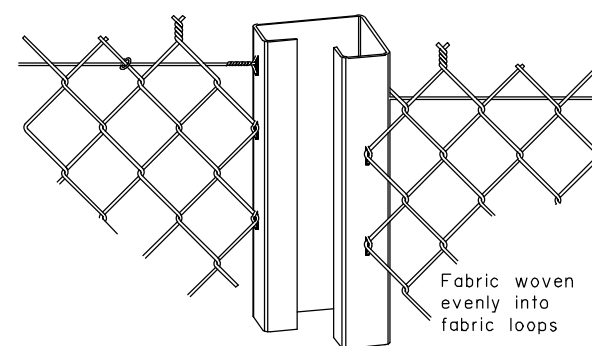

ROLL FORMED POST TOP

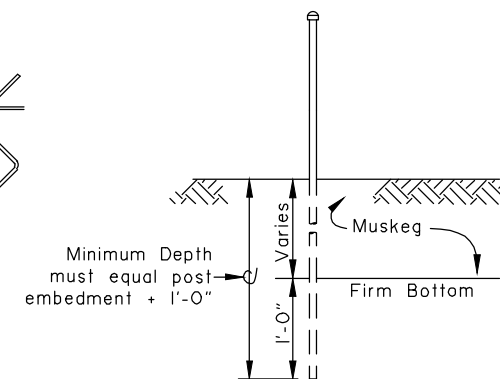

POST SETTING IN MUSKEG AREAS

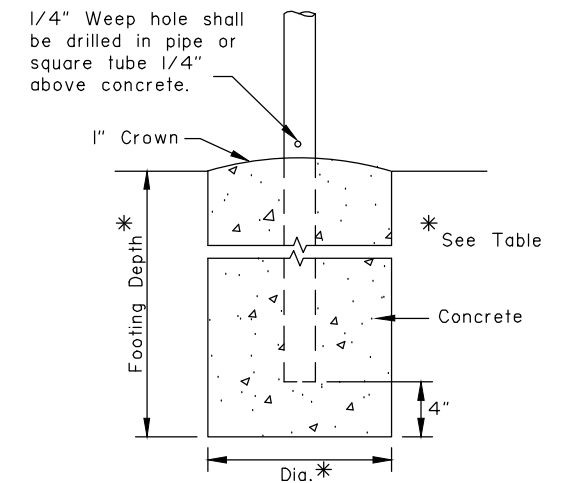

CONCRETE POST FOOTING

FABRIC HEIGHT	POST										TOP OR BRACE RAIL						ALTERNATE POST					
	END-CORNER-PULL					LINE-BRACE					PIPE			ROLL FORMED			H POST		LINE-BRACE			
	PIPE SIZE	WT./FT.	SQUARE TUBE SIZE	WT./FT.	ROLL FORMED SIZE	WT./FT.	FOOTING DEPTH	DIA.	PIPE SIZE	WT./FT.	C POST SIZE	WT./FT.	FOOTING DEPTH	DIA.	PIPE SIZE	WT./FT.	ROLL FORMED SIZE	WT./FT.	H POST SIZE	WT./FT.	LINE-BRACE SIZE	WT./FT.
3'	2"	3.65 #	2" x 2"	4.31 #	3 1/2"x3 1/2"	4.84 #	40"	10"	1 1/2"	2.72 #	1 7/8"x1 5/8"	2.28 #	28"	10"	1 1/4"	2.27 #	1 5/8"	1.35 #	1 1/2"x 1 5/16"	2.27 #	1 7/8"x1 5/8"	2.72 #
4'	"	"	"	"	"	"	"	"	"	"	"	"	"	"	"	"	"	"	"	"	"	"
5'	2"	3.65 #	2" x 2"	4.31 #	3 1/2"x3 1/2"	4.84 #	40"	10"	1 1/2"	2.72 #	1 7/8"x1 5/8"	2.28 #	28"	10"	"	"	"	"	"	"	1 7/8"x1 5/8"	2.72 #
6'	2 1/2"	5.79 #	2 1/2"x2 1/2"	5.59 #	3 1/2"x3 1/2"	4.84 #	48"	15"	2"	3.65 #	2 1/4"x1 45/64"	2.64 #	40"	12"	"	"	"	"	"	"	2 1/4"x2"	4.1 #
7'	"	"	"	"	"	"	"	"	"	"	"	"	"	"	"	"	"	"	"	"	"	"
8'	2 1/2"	5.79 #	2 1/2"x2 1/2"	5.59 #	3 1/2"x3 1/2"	4.84 #	48"	15"	2"	3.65 #	2 1/4"x1 45/64"	2.64 #	40"	12"	"	"	"	"	"	"	2 1/4"x2"	4.1 #

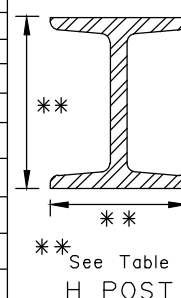

See Table
H POST

State of Alaska DOT&PF
ALASKA STANDARD PLAN
CHAIN LINK FENCE

Adopted as an Alaska Standard Plan by: *Carolyn Morehouse*
Carolyn Morehouse, P.E.
Chief Engineer

Adoption Date: 7/17/2020

Last Code and Stds. Review
By: KLH Date: 7/8/2020

Next Code and Standards Review date: 7/8/2030

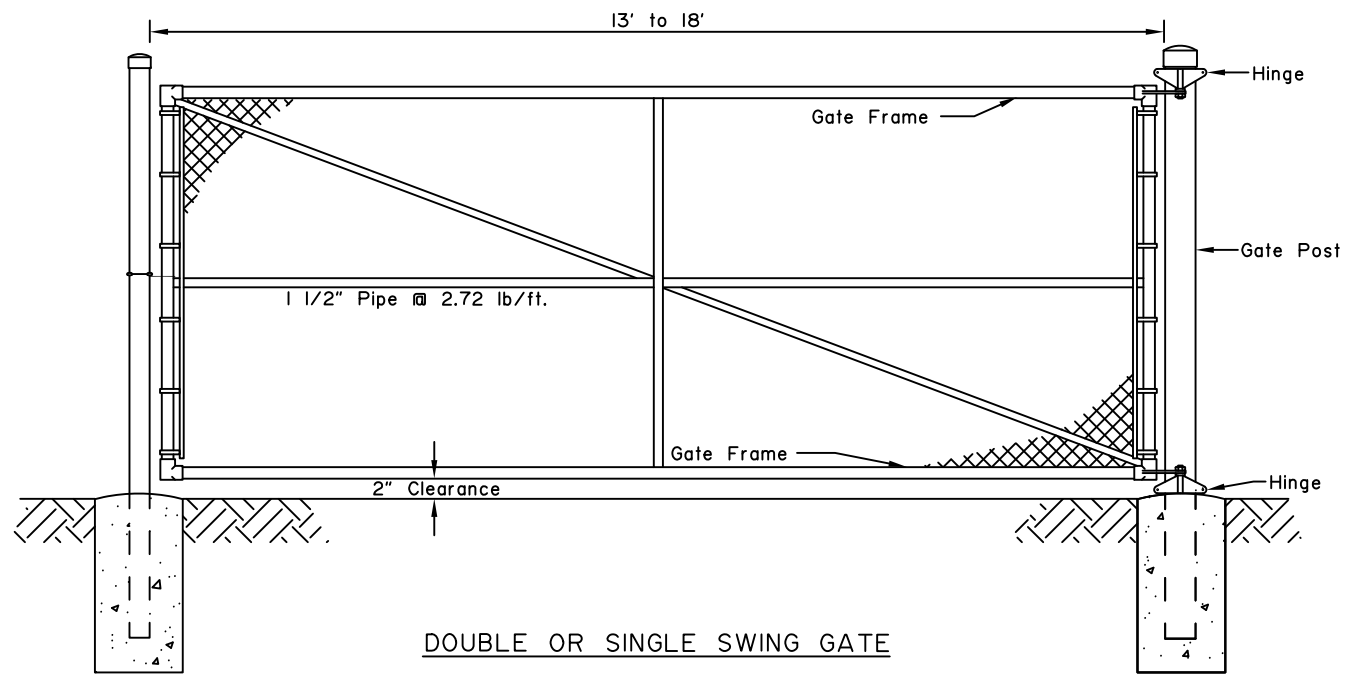

DOUBLE OR SINGLE SWING GATE

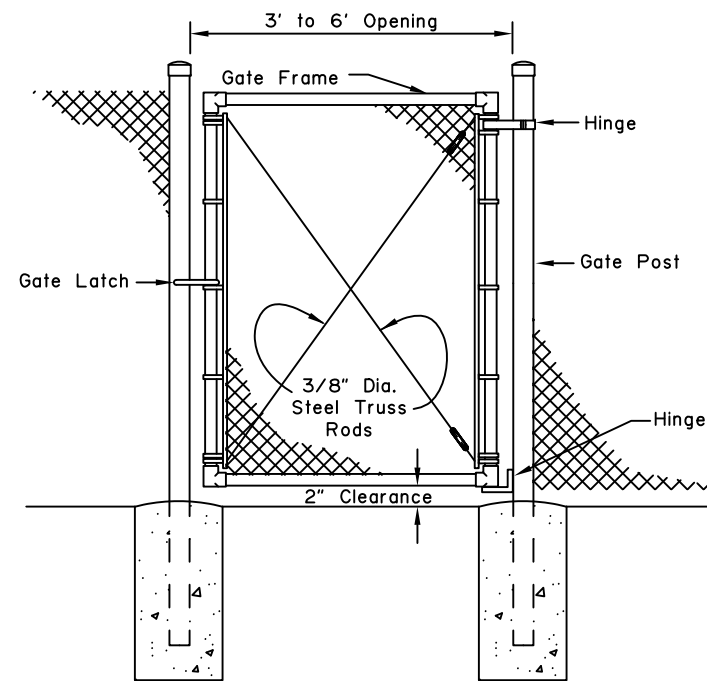

PEDESTRIAN GATE

GENERAL NOTES:

1. Details shown are to indicate general design only. Dimensions may vary slightly among the manufacturers.
2. Gate fabric shall be of the same design and height of line fence fabric.
3. Gate fabric shall be furnished with knuckle selvage top and bottom.
4. Concrete footings shall be of the same depth as end posts with a diameter 1 1/2 times larger except as shown for gate stop.
5. Gate frames may be fabricated by welding or riveting and shall be braced to eliminate sagging. Hinges, latches and other gate appurtenances shall be of sufficient strength and design to assure easy trouble free operation.

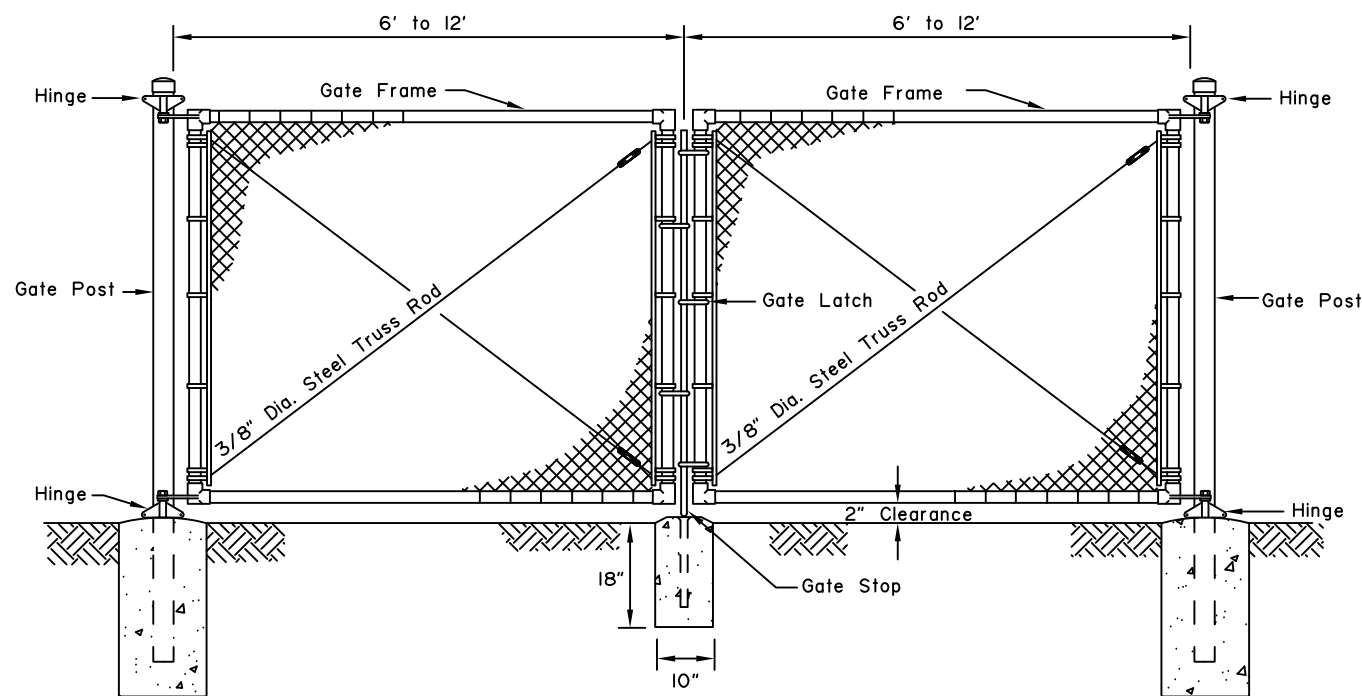

DOUBLE SWING GATE

Gate Fabric Height	Gate Opening		GATE POST						GATE FRAME			
	SINGLE GATE	DOUBLE GATE	ST'D PIPE SIZE	WT./FT.	SQUARE TUBE SIZE	WT./FT.	ROLL FORMED SIZE	WT./FT.	ST'D PIPE SIZE	WT./FT.	SQUARE TUBE SIZE	WT./FT.
3' to 5'	3' to 6'	6' to 12'	2"	3.65 #	2" x 2"	4.31 #	3 1/2" x 3 1/2"	5.14 #	1 1/2"	2.72 #	2" x 2"	4.31 #
"	7' to 12'	13' to 24'	2 1/2"	5.79 #	2 1/2" x 2 1/2"	5.59 #	" "	" "	" "	" "	" "	" "
"	13' to 18'	25' to 36'	"	"	" "	" "	" "	" "	" "	" "	" "	" "
6' to 8'	3' to 6'	6' to 12'	2 1/2"	5.79 #	2 1/2" x 2 1/2"	5.59 #	3 1/2" x 3 1/2"	5.14 #	1 1/2"	2.72 #	" "	" "
"	7' to 12'	13' to 24'	3 1/2"	9.11 #	3 1/2" x 3 1/2"	8.14 #	---	---	2"	3.65 #	" "	" "
"	13' to 18'	25' to 36'	6"	18.97 #	6" x 6"	18.82 #	---	---	" "	" "	2" x 2"	4.31 #

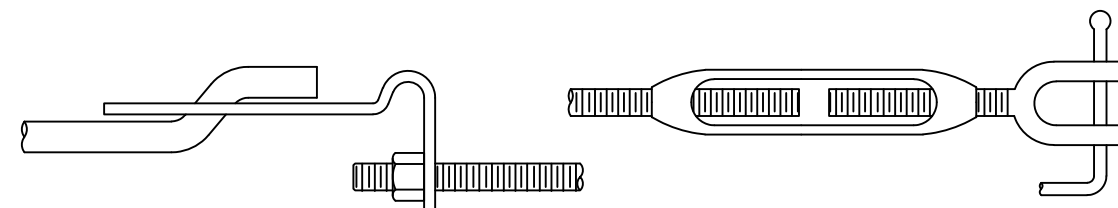

TYPICAL TRUSS ROD TIGHTENERS

State of Alaska DOT&PF
ALASKA STANDARD PLAN
CHAIN LINK FENCE
GATE

Adopted as an Alaska Standard Plan by: *Kenneth J. Fisher*
Kenneth J. Fisher, P.E.
Chief Engineer

Adoption Date: 02/08/2019

Last Code and Stds. Review By: Date:

Next Code and Standards Review date: 02/08/2029

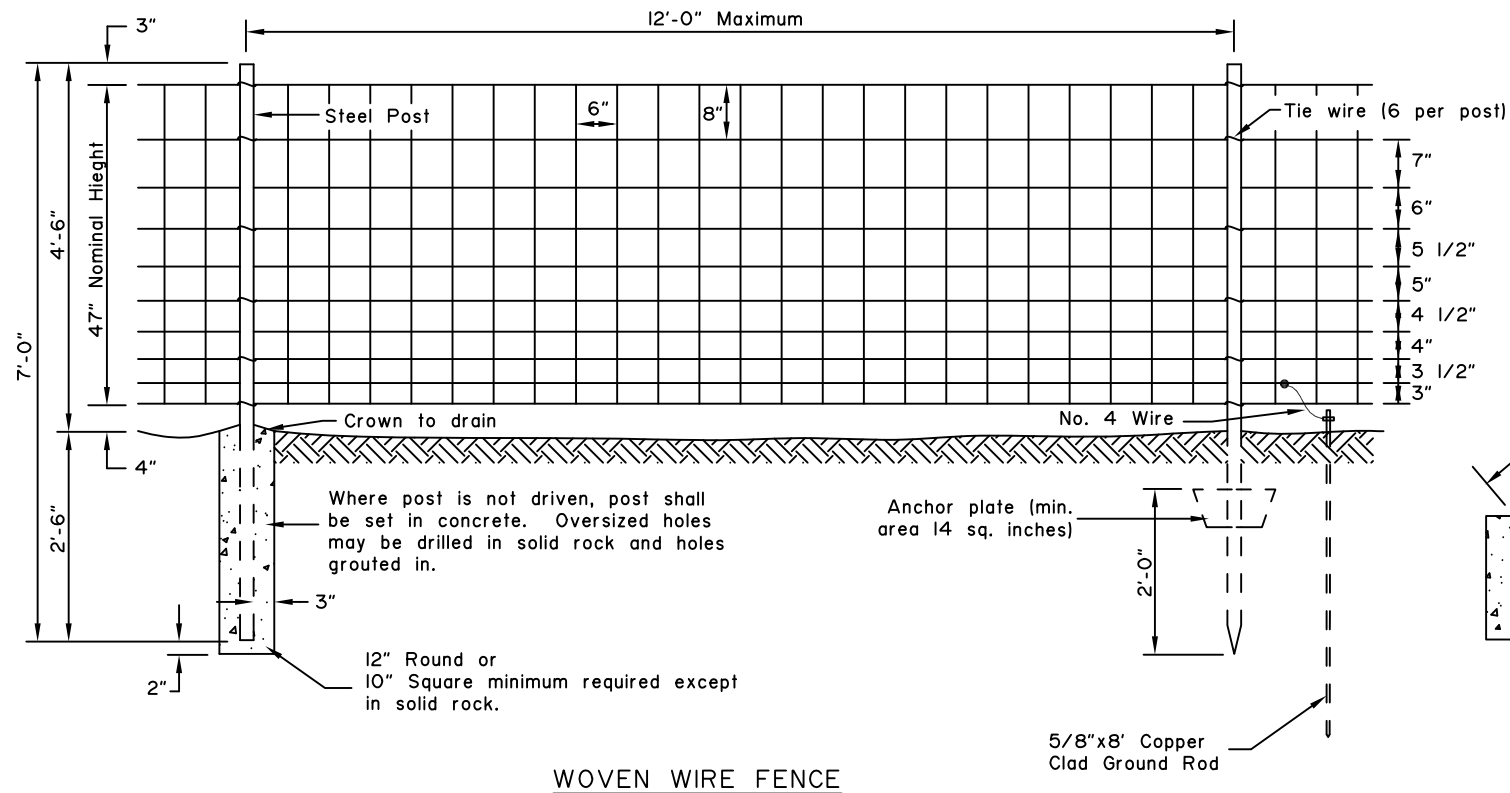

WOVEN WIRE FENCE

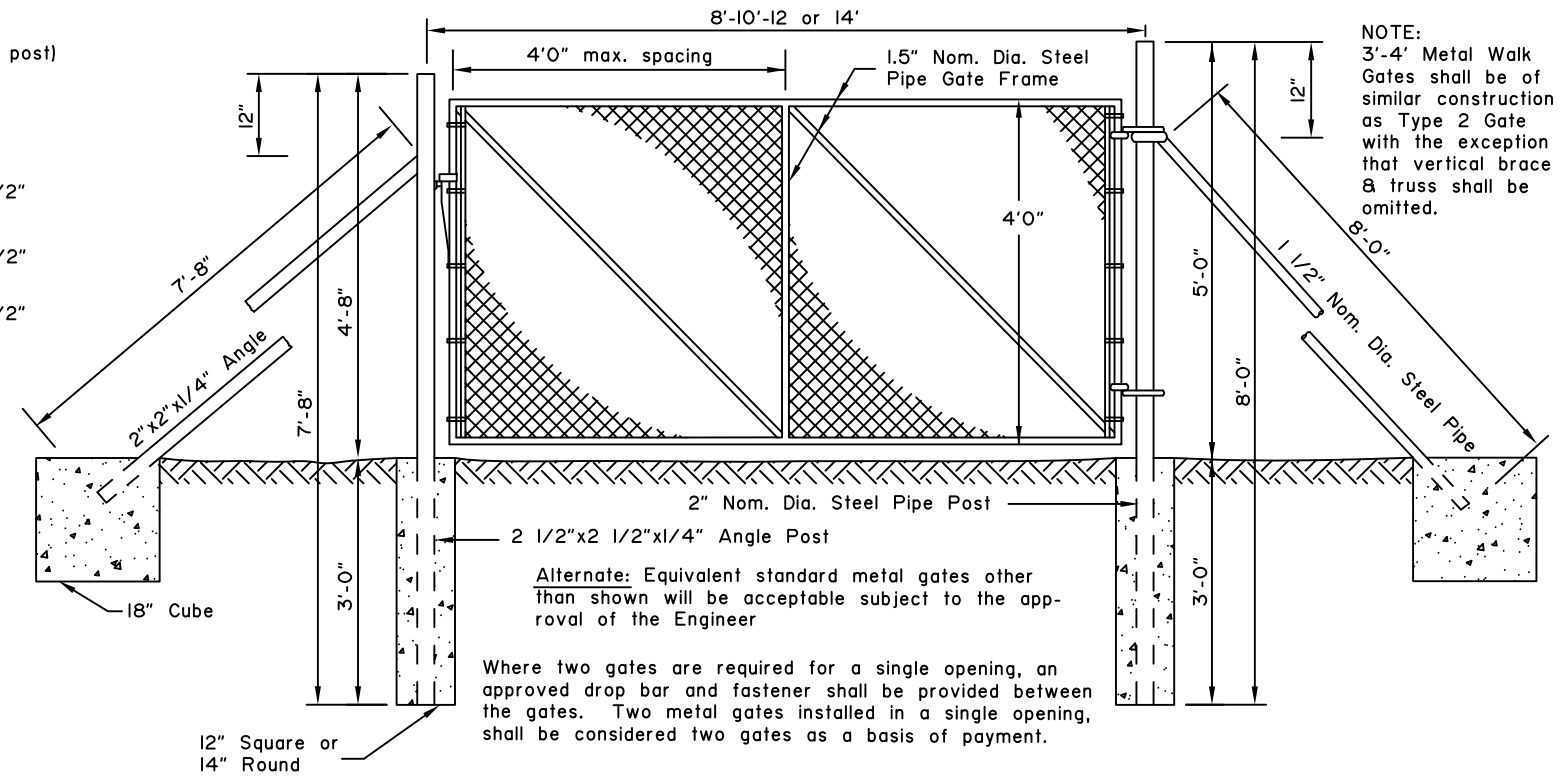

NOTE:
3'-4" Metal Walk Gates shall be of similar construction as Type 2 Gate with the exception that vertical brace & truss shall be omitted.

Where two gates are required for a single opening, an approved drop bar and fastener shall be provided between the gates. Two metal gates installed in a single opening, shall be considered two gates as a basis of payment.

TYPE 2 GATE

GENERAL NOTES:

- Gates shall be hung on standard angle or steel pipe posts.
- Metal posts shall be angle steel or steel pipe with dimensions as shown and with the following nominal weights per linear foot: 1 1/2" Nom. Dia.-2.72 lbs., 2" Nom. Dia.-3.65 lbs.
- Place fencing and gates where shown on plans.
- Gate shall be manufactured of steel pipe not less than 1" Nom. Dia., (Nom. wt. 1.68 lbs. per linear foot) for frame and vertical brace. Wire mesh shall be 9 gage and affixed to the frame with 9 gage G.I. wire. Each gate shall be equipped with one standard adjustable diagonal truss rod from corner to corner. Hinges and 2-way self closing latch shall be of an approved rustproof malleable iron or steel.
- Woven wire top and bottom strands shall be 9 gage intermediate strands and vertical fillers shall be 11 gage.
- Corner, end and brace posts shall be 2" Nom. Dia. pipe, (Nom. wt. 3.65 lbs per linear foot) or 2 1/2"x2 1/2"x1/4" angle (Nom. wt. 4.1 lbs per linear foot).
- Metal line posts (Nominal wt. 1.33 lbs. per linear foot) shall have knobs, punched web or corrugated edges to hold hold fencing.
- Metal braces shall be 1 1/2" Nom. Dia. pipe (Nom. wt.2.72 lbs per linear foot) or 2"x2"x1/4" angle (Nom. wt. 3.19 lbs. per linear foot.)
- Wire fencing shall be placed on side of post facing the highway. Special bracing or location may be required when fencing crosses or parallels streams, bodies of water or sags in the fence line.
- Tie wires shall be 10 gage.
- All wire, posts and hardware shall be galvanized. Weights and gages specified are minimums before galvanizing.

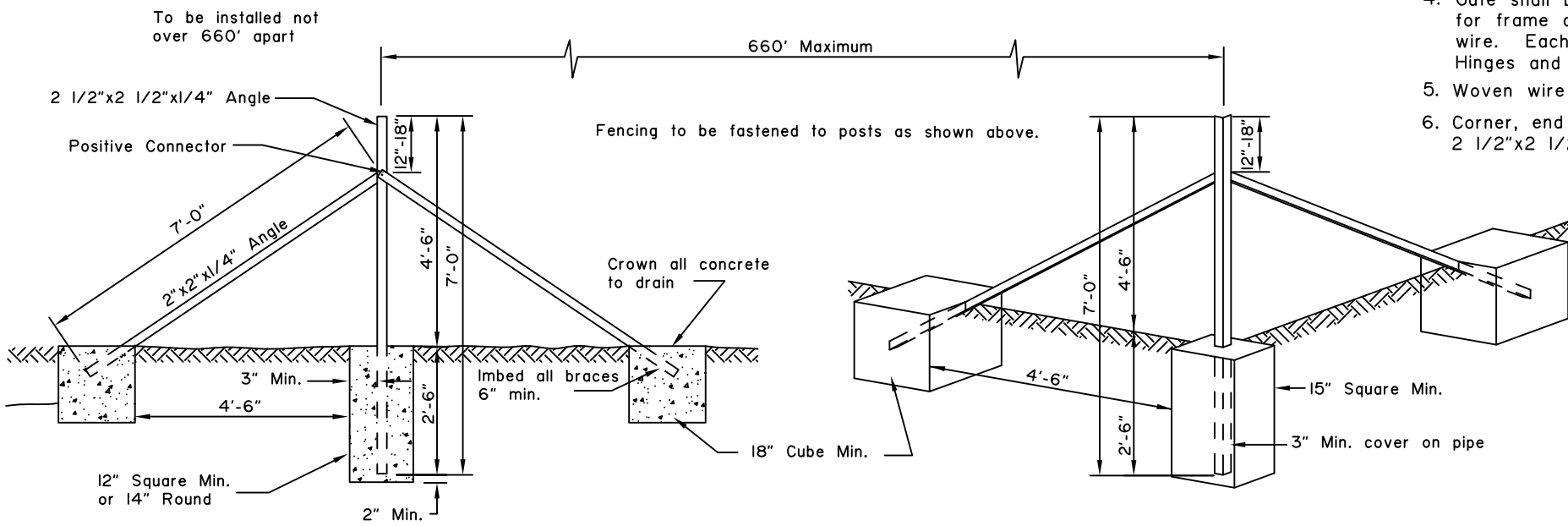

METAL LINE BRACE

METAL CORNER BRACE

To be installed not over 660' apart

660' Maximum
Fencing to be fastened to posts as shown above.

State of Alaska DOT&PF
ALASKA STANDARD PLAN

WOVEN WIRE FENCE

Adopted as an Alaska Standard Plan by: *Kenneth J. Fisher*
Kenneth J. Fisher, P.E.
Chief Engineer

Adoption Date: 02/08/2019

Last Code and Stds. Review By: _____ Date: _____

Next Code and Standards Review date: 02/08/2029

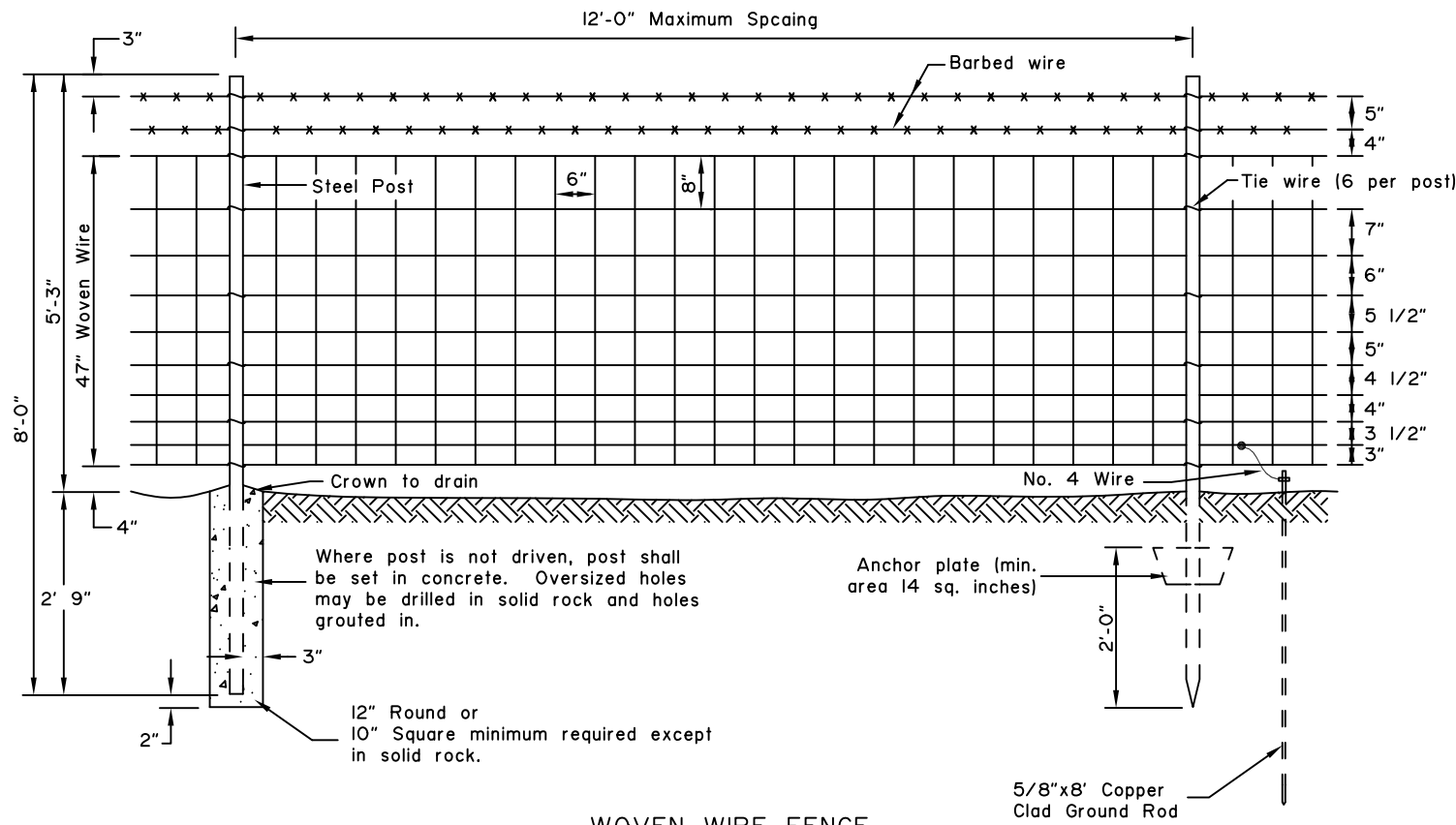

WOVEN WIRE FENCE

NOTE: 3'-4' Metal Walk Gates shall be of a similar construction as Type 2 Gate with the exception that vertical brace & truss shall be omitted.

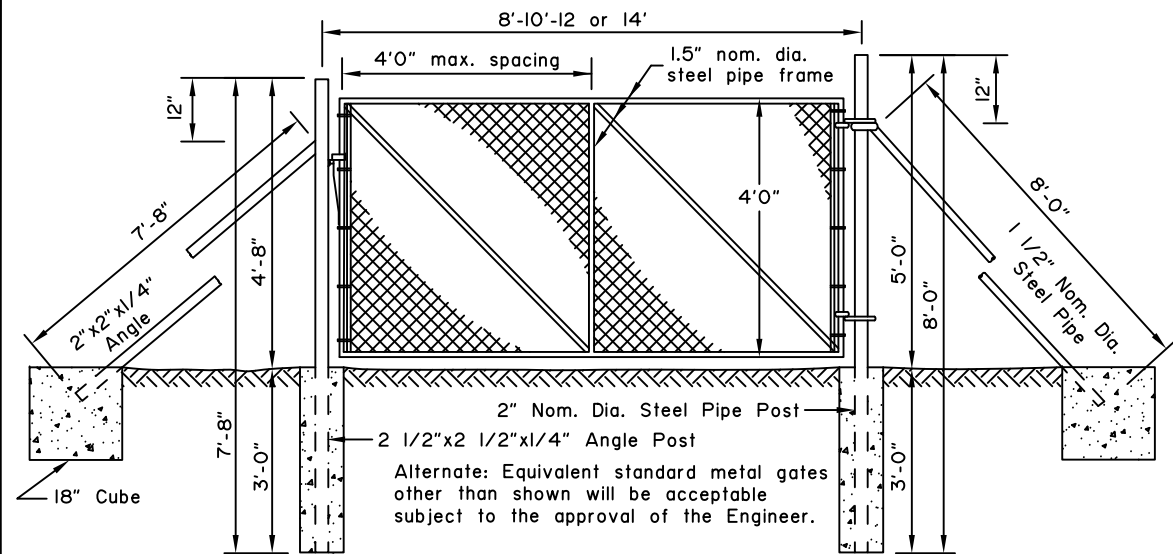

TYPE 2 GATE

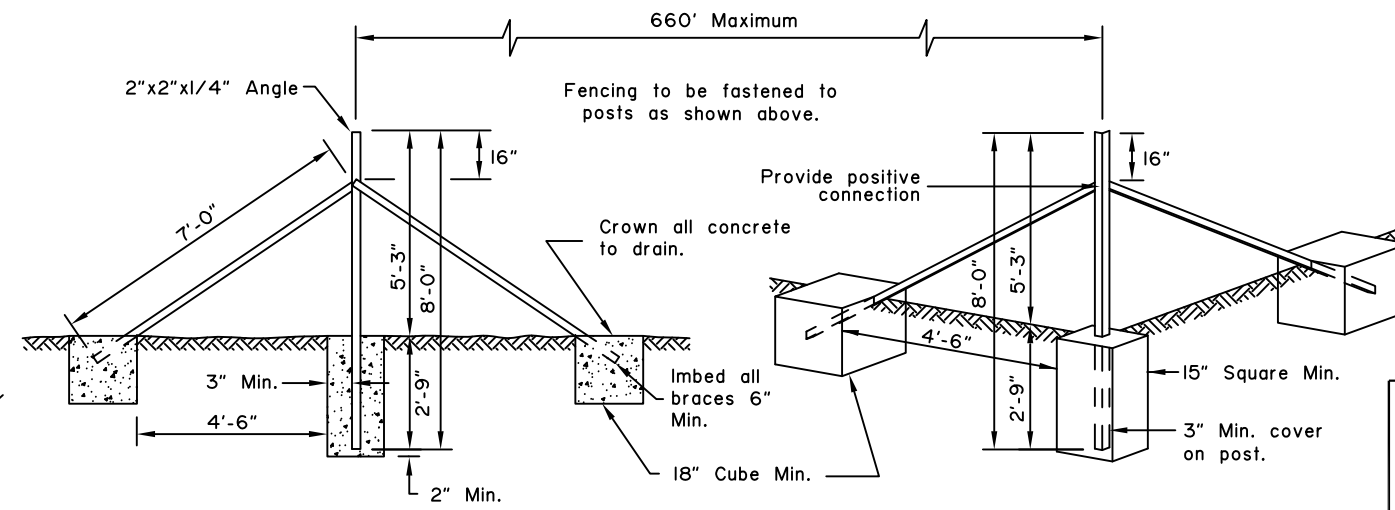

METAL LINE BRACE

Installed at not more than 660' apart.

METAL CORNER BRACE

GENERAL NOTES:

- Gate shall be hung on standard angle or steel pipe posts.
- Metal posts shall be angle steel or steel pipe with dimensions as shown and with the following nominal weights per linear foot: 1 1/2" Nominal Diameter-2.72 lbs, 2" Nominal Diameter-3.65 lbs.
- Install fencing and gates where shown on plans.
- Gate shall be manufactured of steel pipe not less than 1" Nominal Diameter, (Nominal wt. 1.68 lbs per linear foot) for frame and vertical brace. Wire mesh shall be 9 gage and affixed to the frame with 9 gage G.I. wire. Each gate shall be equipped with one standard adjustable diagonal truss rod from corner to corner. Hinges and 2-way self closing latch shall be of an approved rustproof malleable iron or steel.
- Woven wire top and bottom strands shall be 9 gage intermediate strands and vertical fillers shall be 11 gage.
- Corner, end and brace posts shall be 2" Nominal Diameter pipe. (Nominal wt. 3.65 lbs. per linear foot) or 2 1/2"x2 1/2"x1/4" angle (Nominal wt. 4.1 lbs. per linear foot).
- Metal line posts (Nominal wt. 1.33 lbs. per linear foot) shall have knobs, punched web or corrugated edges to hold fencing.
- Provide metal braces made of 1 1/2" nominal diameter pipe with a nominal weight of 2.72 lbs per linear foot or 2"x2"x1/4" angle with a nominal weight of 3.19 lbs per linear foot.
- Wire fencing shall be placed on side of post facing the highway. Special bracing or location may be required when fencing crosses or parallels streams, bodies of water or sags in the fence line.
- Tie wires shall be 10 gage.
- All wire, posts and hardware shall be galvanized. Weights and gages specified are minimums before galvanizing.
- Barbed wire shall be 12 1/2 gage, with 4 point 14 gage round barbs at 5" maximum spacing.

TYPICAL BRACING DETAIL

State of Alaska DOT&PF
ALASKA STANDARD PLAN
WOVEN WIRE FENCE
WITH BARBED WIRE

Adopted as an Alaska Standard Plan by: *Kenneth J. Fisher*
Kenneth J. Fisher, P.E.
Chief Engineer

Adoption Date: 02/08/2019

Last Code and Stds. Review
By: Date:

Next Code and Standards Review date: 02/08/2029

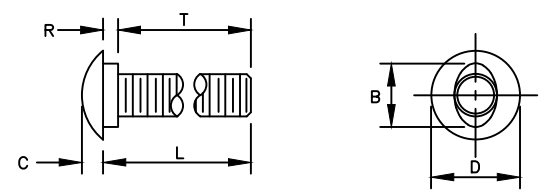

B	C	D	L (Length)	R	T (Thread Length)
15/16"	5/16"	1 5/16" or 1 7/16"	As Required	7/32"	As Required

5/8" BUTTONHEAD BOLT
(FBB01-05)

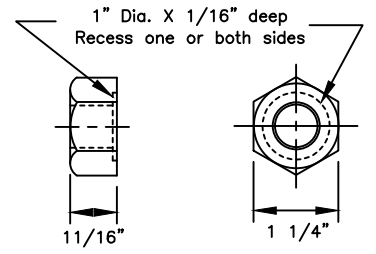

5/8" Dia. RECESSED HEX NUT
(FBB01-05)

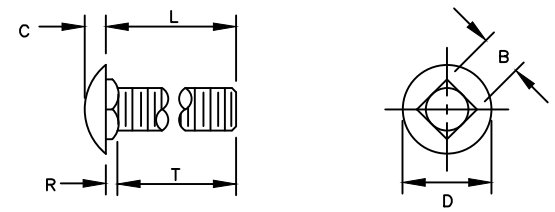

B	C	D	L (Length)	R	T (Thread Length)
5/8"	5/16"	1 5/16"	As Required	3/16"	As Required

5/8" Dia. CARRIAGE BOLT
(FBC10-20)

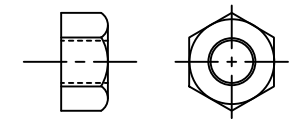

STANDARD HEX NUT

GENERAL NOTES:

- All covered hardware shall comply with the Task Force 13 (TF13) Guide to Standardized Roadside Safety Hardware online publication. Designators given when possible in parentheses.

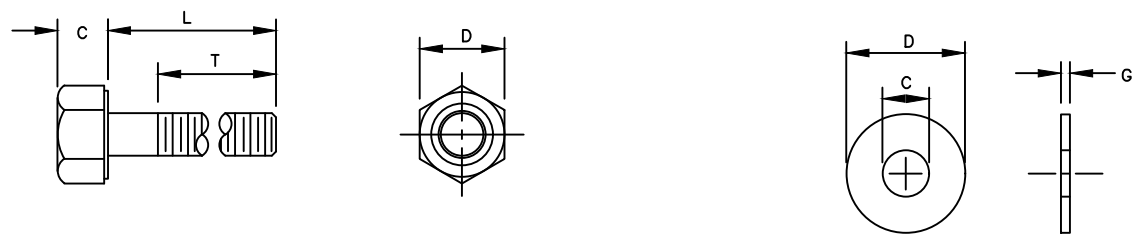

Bolt Size	C	D	L (Length)	T (Thread Length)
5/16"	—	—	1 1/2"	7/8"
5/16"	—	—	1"	1"
3/8"	—	—	7 1/2"	1 1/2"
1/2"	—	—	1 1/2"	1 1/2"
1/2"	—	—	1 1/4"	1 1/4"
5/8" H.S.	5/16"	7/8"	8"	1 1/2"
5/8"-11	—	—	1 1/2"	1 1/2"
3/4"	—	—	1 1/2"	1 1/2"
3/4"	—	—	As Required	2"
3/4" H.S.	15/32"	1 1/4"	2"	1 1/2"

STANDARD HEX BOLTS

For Bolt #	C	D	G
3/8"	7/16"	1"	5/64"
1/2"	17/32"	1 1/16"	3/32"
1/2" H.S.	17/32"	1 1/16"	3/32"
5/8"	11/16"	1 3/4"	9/64"
3/4"	13/16"	1 15/32"	9/64"
3/4" H.S.	13/16"	2"	5/32"
1"	1 1/16"	2"	9/64"

STANDARD STEEL WASHERS

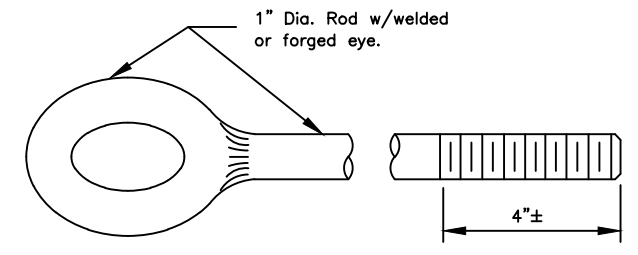

EYE BOLT

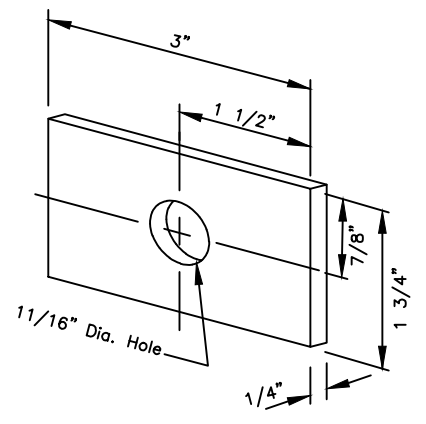

FLAT PLATE WASHER

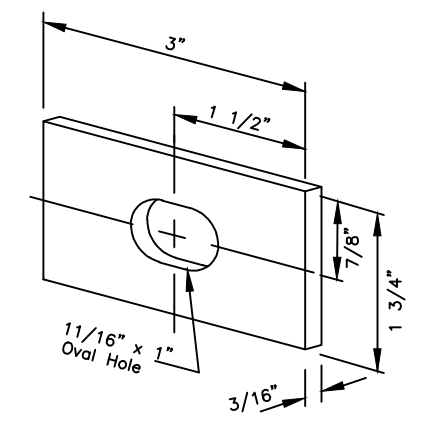

RECTANGULAR POST BOLT WASHER
(FWR03)

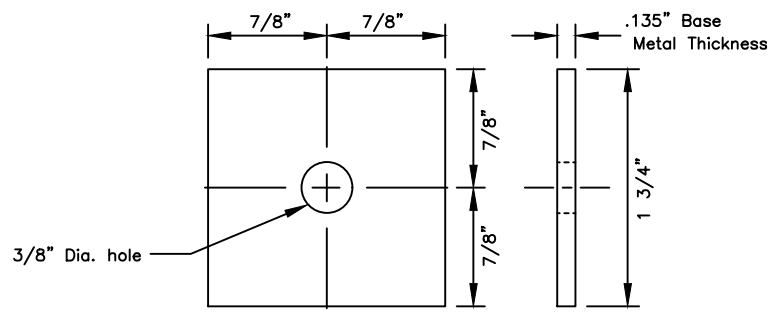

SQUARE STEEL WASHER
(FWR01)

State of Alaska DOT&PF
ALASKA STANDARD PLAN

**STANDARD GUARDRAIL
HARDWARE
(NUTS, BOLTS & WASHERS)**

Adopted as an Alaska Standard Plan by: *Carolyn Morehouse*
Carolyn Morehouse, P.E.
Chief Engineer

Adoption Date: 7/17/2020

Last Code and Stds. Review
By: KLK Date: 7/8/2020
Next Code and Standards Review Date: 7/8/2030

GENERAL NOTES:

1. All covered hardware shall comply with the Task Force 13 (TF13) Guide to Standardized Roadside Safety Hardware online publication. Designators given when possible in parentheses.
2. Install back-up plates between blockouts and w-beam or thrie-beam rail at intermediate (non-splice) posts when steel blockouts are used but not with wood, rubber, plastic, or other approved blockouts.

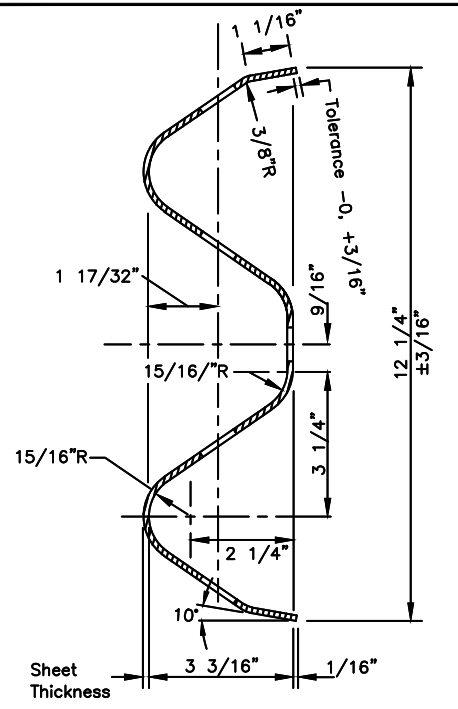

SECTION A-A
(cross section same as RWM02a-b)

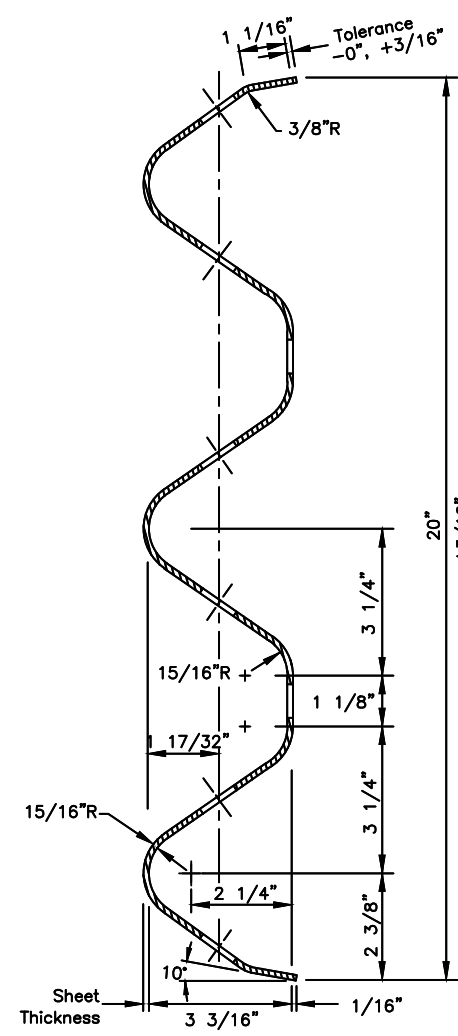

SECTION C-C
(RTM01a-02b)

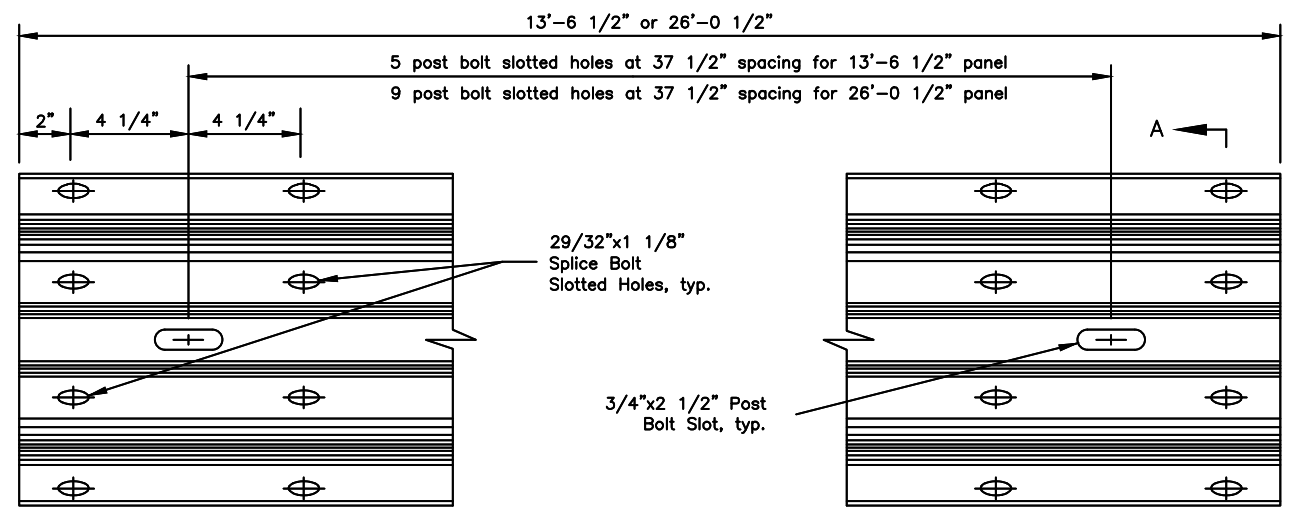

STANDARD W-BEAM PANEL (RWM04a-b)

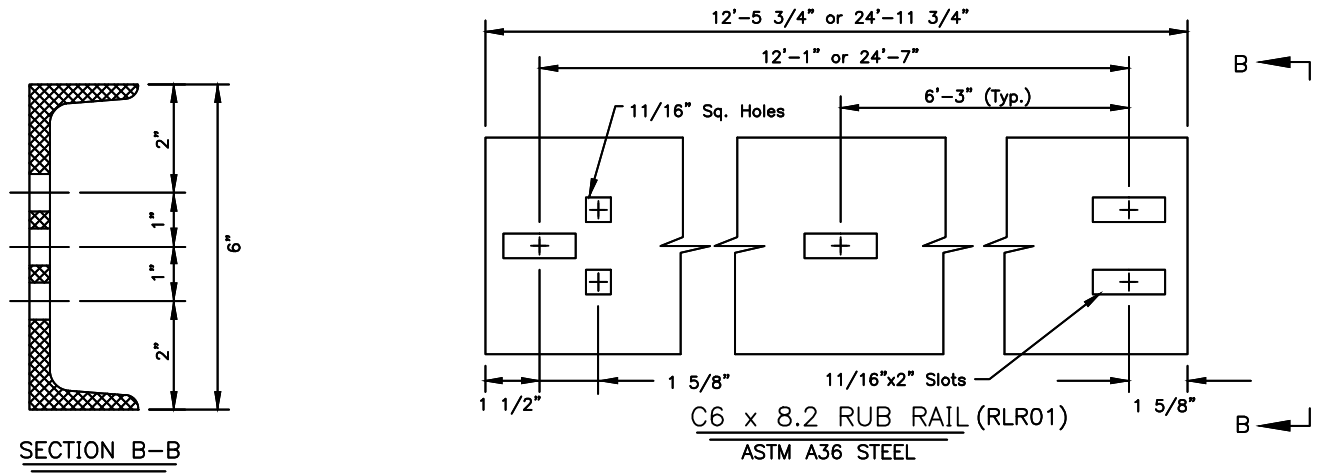

C6 x 8.2 RUB RAIL (RLR01)
ASTM A36 STEEL

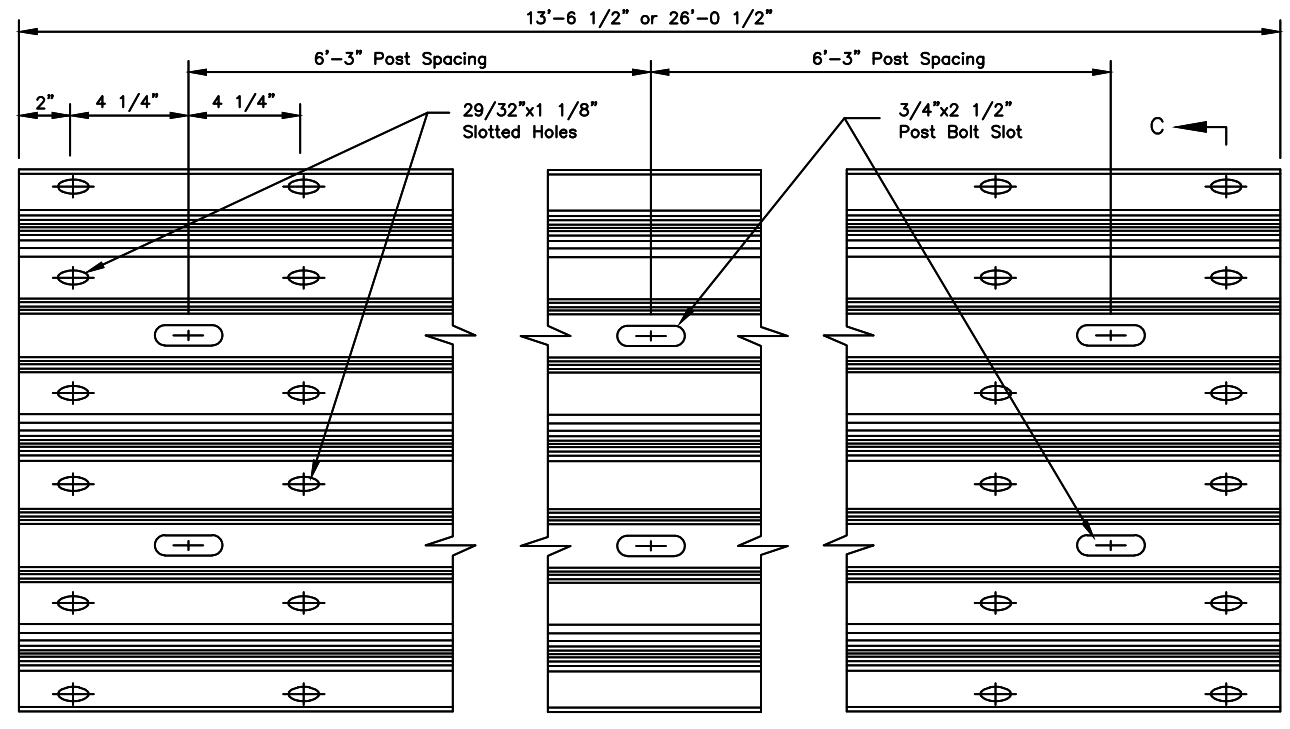

STANDARD THRIE BEAM PANEL (RTM01a-02b)

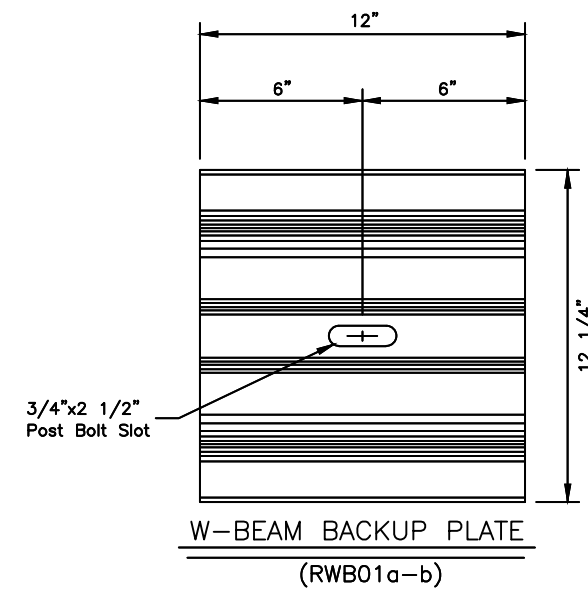

W-BEAM BACKUP PLATE (RWB01a-b)

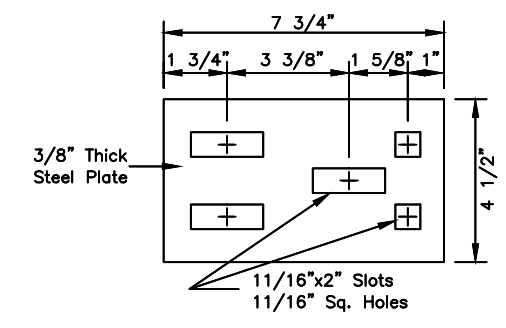

SPLICE PLATE (RLR01)
ASTM A36 STEEL

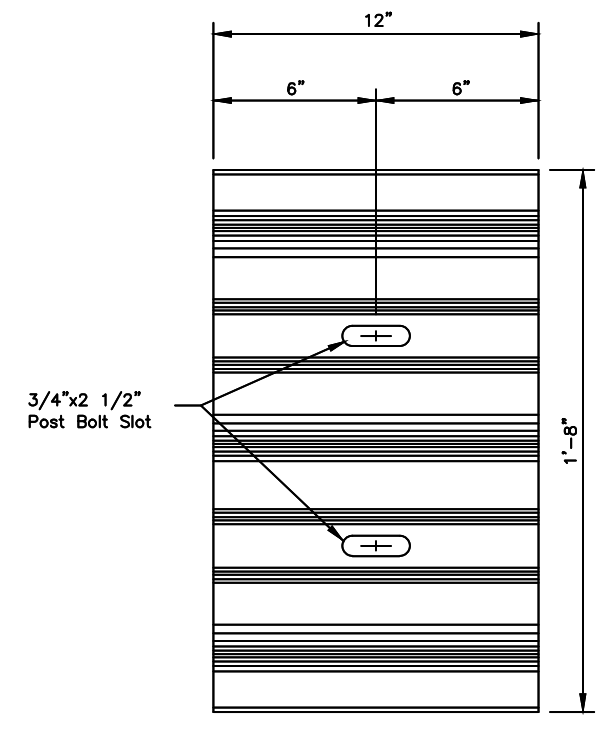

THRIE BEAM BACKUP PLATE (RTB01a-02b)

State of Alaska DOT&PF
ALASKA STANDARD PLAN

**STANDARD GUARDRAIL
HARDWARE
(RAILS AND SPLICES)**

Adopted as an Alaska Standard Plan by: *Carolyn Morehouse*
Carolyn Morehouse, P.E.
Chief Engineer

Adoption Date: 7/17/2020

Last Code and Stds. Review
By: KLK Date: 7/8/2020
Next Code and Standards Review Date: 7/8/2030

GENERAL NOTES:

1. W-Beam and Thrie Beam Terminal Connectors shall conform to AASHTO M 180, Class B, Type II.
2. W-Beam end sections shall conform to AASHTO M 180, Class A, Type II.
3. All covered hardware shall comply with the Task Force 13 (TF13) Guide to Standardized Roadside Safety Hardware online publication. Designators given when possible in parentheses.

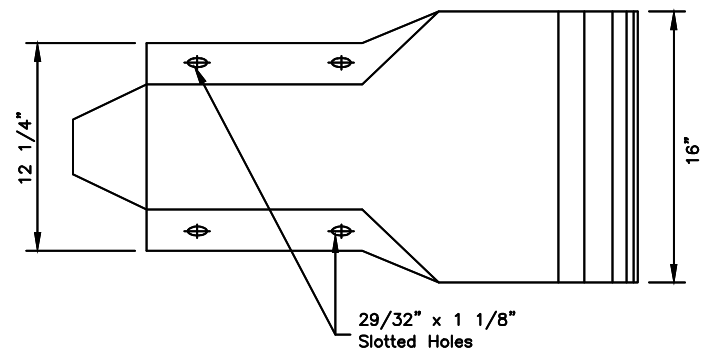

PROFILE

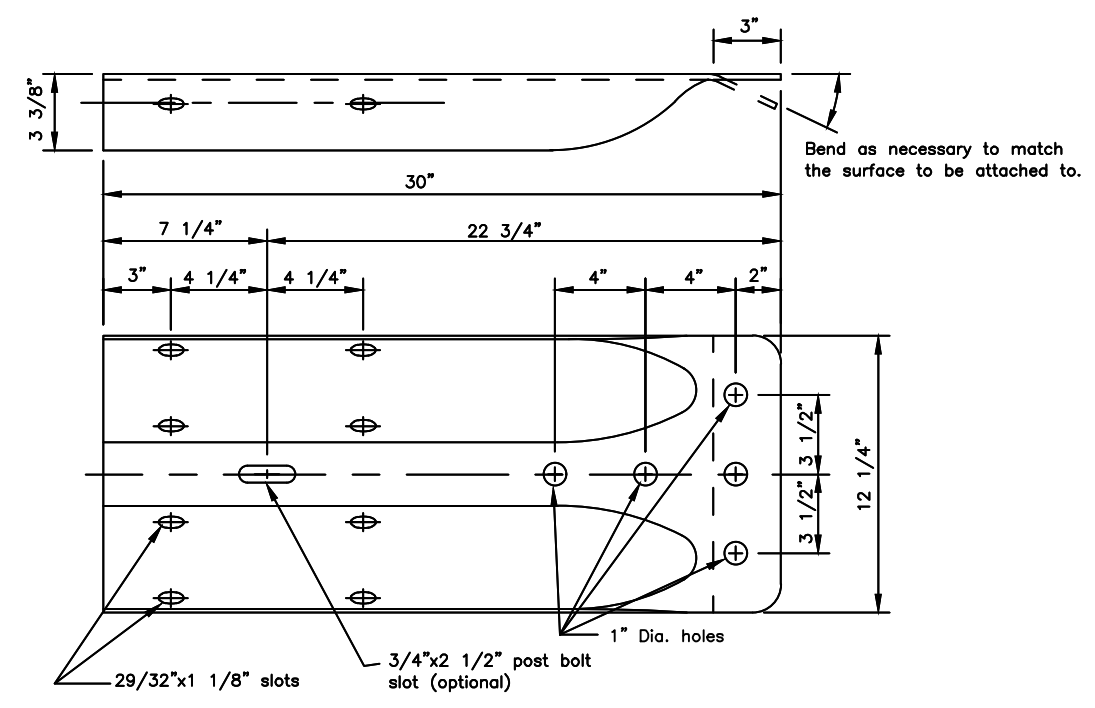

STANDARD W-BEAM TERMINAL CONNECTOR
(RWE02)

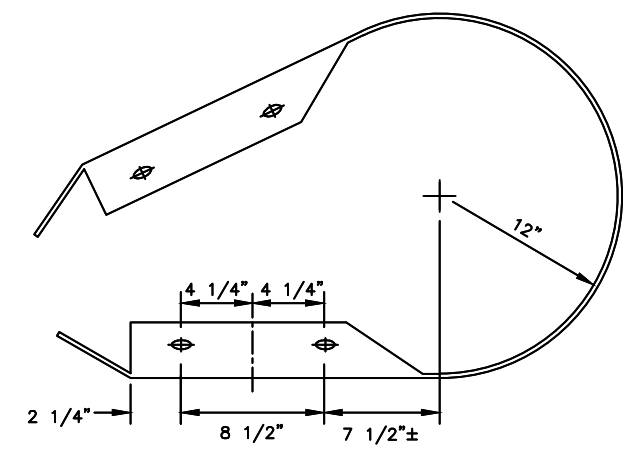

W-BEAM PLAN VIEW

*Radius to be specified on the plans

STANDARD W-BEAM END SECTION
(RWE06)

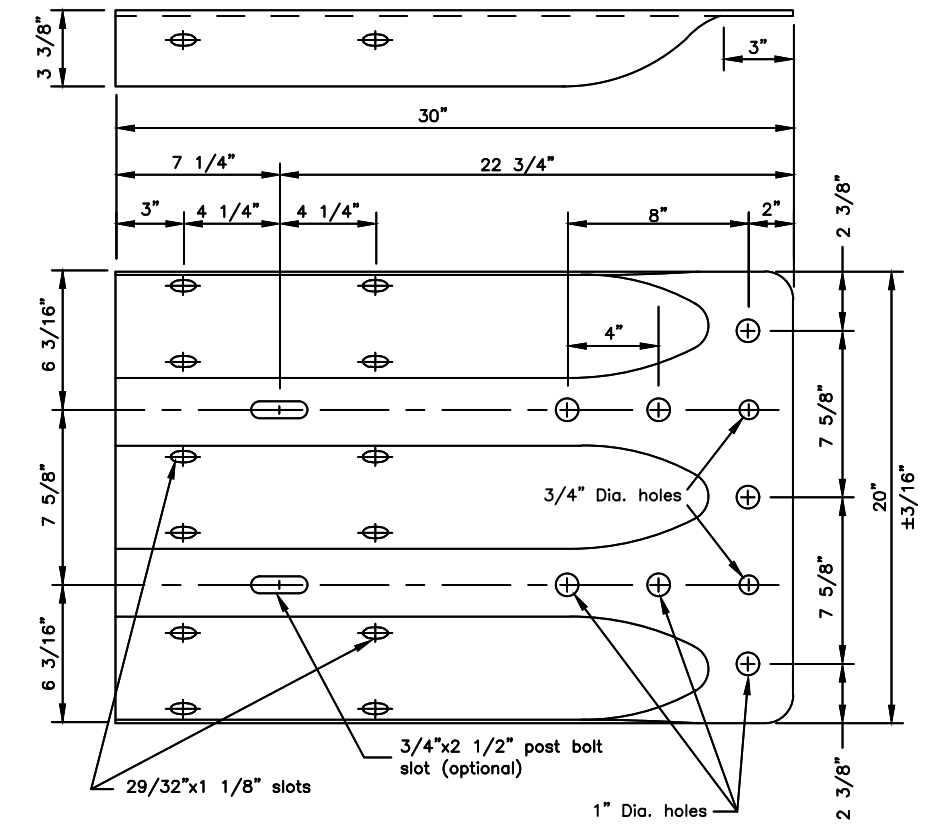

STANDARD THRIE BEAM TERMINAL CONNECTOR
(RTE01b)

State of Alaska DOT&PF
ALASKA STANDARD PLAN

STANDARD GUARDRAIL
HARDWARE
(TERMINAL CONNECTORS)

Adopted as an Alaska Standard Plan by: *Carolyn Morehouse*
Carolyn Morehouse, P.E.
Chief Engineer

Adoption Date: 7/17/2020

Last Code and Stds. Review
By: KLK Date: 7/8/2020
Next Code and Standards Review Date: 7/8/2030

G-00.05

GENERAL NOTES:

1. Cable Anchor Plate may be formed in single unit or welded fabrication.
2. Anchor Cable Assembly must conform to AASHTO M 30 with Type II Wire Rope.
3. Provide Sleeve for Wood Posts meeting the requirements of ASTM A53 and made of 2-inch galvanized standard pipe. Sleeve shall be a tight, pressed fit in post.
4. Attach radius ID plates to all shop-bent guardrail sections. Bolt the ID plates to the back side of the guardrail panel with the lower splice bolt nearest the P.C. of the radius.
5. Show the Rail bend radius, in feet, as "XX" on the radius ID plate. Digits shall be etched or stamped and have a min. height of 1 1/2" and a max. width of 3/4". Galvanize the plate after the digits are marked.
6. All covered hardware shall comply with the Task Force 13 (TF13) Guide to Standardized Roadside Safety Hardware online publication. Designators given when possible in parentheses.

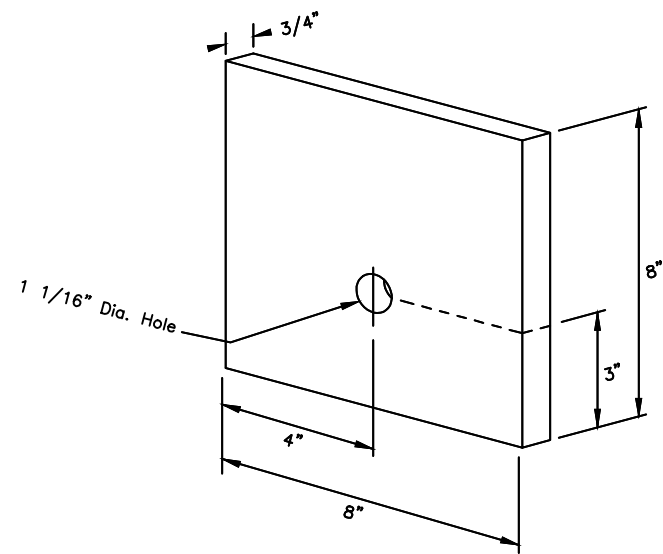

BEARING PLATE for CRT TERMINAL ANCHOR
(FPB01)

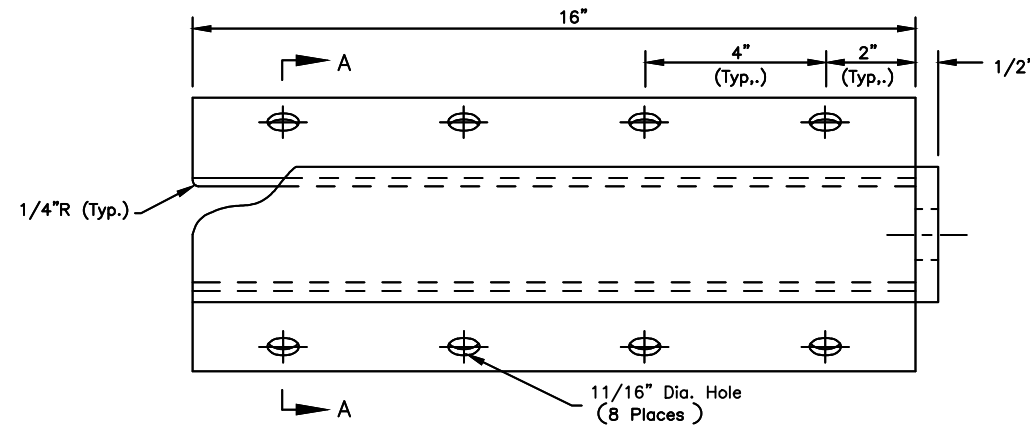

CABLE ANCHOR PLATE
(FPA01)

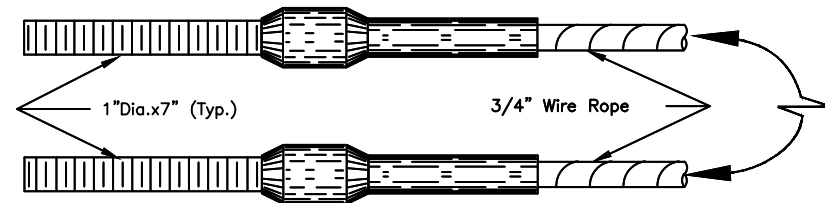

SWAGED FITTING DETAIL
(FCA01-02)

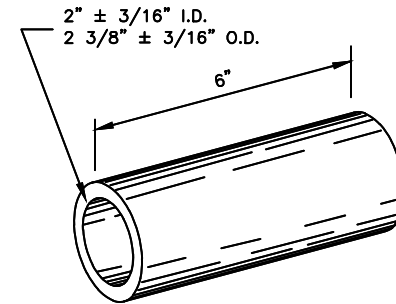

SLEEVE DETAIL
(FMM02)

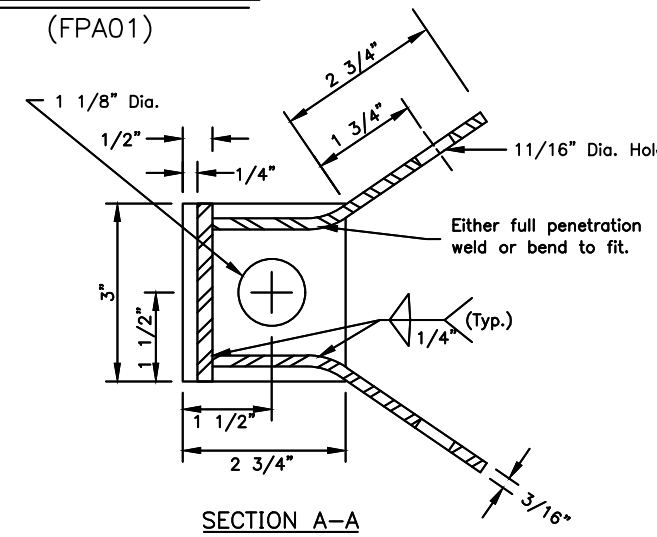

SECTION A-A

CONTROLLED RELEASE TERMINAL HARDWARE DETAILS

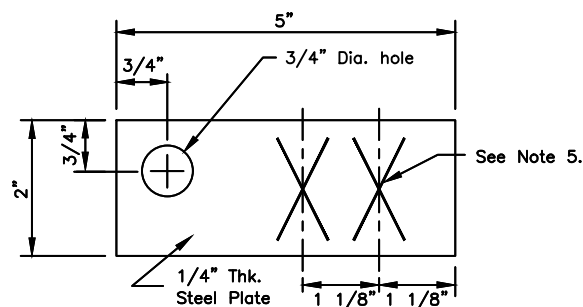

RADIUS I.D. PLATE

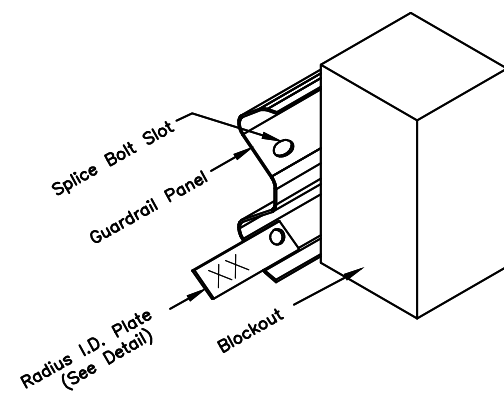

RADIUS I.D. PLATE
MOUNTING DETAIL

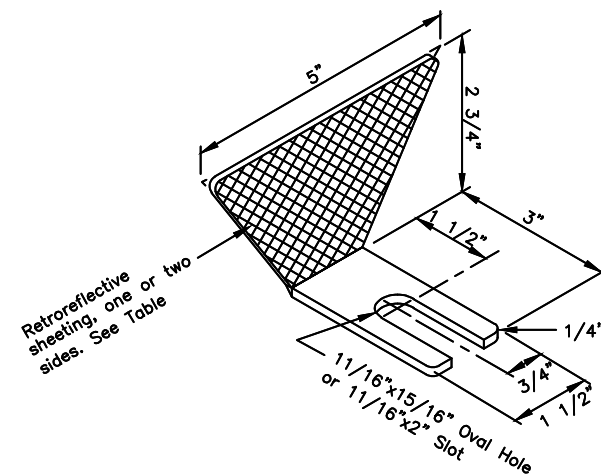

GUARDRAIL REFLECTOR

Guardrail Reflector Table

Type	Color	ReflectORIZED
A	White	Front & Rear
B	White	Front
C	Yellow	Front
D	Yellow	Front & Rear

State of Alaska DOT&PF
ALASKA STANDARD PLAN

STANDARD GUARDRAIL
HARDWARE
(MISCELLANEOUS)

Adopted as an Alaska
Standard Plan by: *Carolyn Morehouse*
Carolyn Morehouse, P.E.
Chief Engineer

Adoption Date: 7/17/2020

Last Code and Stds. Review
By: KLK Date: 7/8/2020

Next Code and Standards Review Date: 7/8/2030

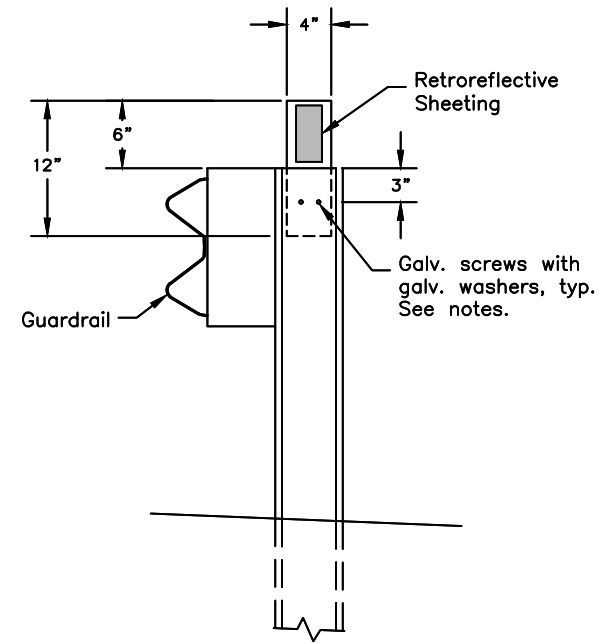

GUARDRAIL FLEXIBLE DELINEATOR DETAIL

(Steel post shown – similar for wood post)

CONSTRUCTION NOTES

1. Install guardrail flexible delineators where shown on the plans.
2. Install guardrail flexible delineators at 50 foot spacing, unless otherwise noted on the plans. Install not less than 2 delineators per guardrail run.
3. Use 3" x 5" white/yellow/red retroreflective sheeting as required per Standard Plan T-05. Install retroreflective sheeting on both sides of delineator on two-way roads.
4. Attach 4" x 12" flexible delineators to the top of new guardrail posts, on the trailing side of the posts relative to the adjacent lane's direction of travel.
5. Use 2 each 1/4" dia. x 1-1/2" long galvanized lag screws for attaching to wood posts and 2 each 1/4" dia. x 3/4" long galvanized self-drilling fasteners for steel posts. Install a galvanized washer between the fastener head and the flexible delineator.

State of Alaska DOT&PF
ALASKA STANDARD PLAN

STANDARD GUARDRAIL
HARDWARE
(FLEXIBLE DELINEATORS)

Adopted as an Alaska
Standard Plan by: *Carolyn Morehouse*
Carolyn Morehouse, P.E.
Chief Engineer

Adoption Date: 7/17/2020

Last Code and Stds. Review
By: KLK Date: 7/8/2020

Next Code and Standards Review Date: 7/8/2030

CONSTRUCTION NOTES:

1. No fixed objects allowed within 60" of the back of the guardrail post.
2. Shop form guardrail on curves with a radius of less than 717'.
3. Splice plate connections shall meet ASTM F3125, Grade A325 for bolts and A563, Grade A for hex nuts.
4. HSS Steel Tube box beam rail elements shall meet ASTM A500 Grade B.
5. Provide guardrail reflectors conforming to Standard Plan G-00 and Section 606 of the Standard Specifications.
6. Mount guardrail reflectors every 48' on tangents and 24' on curves. Start reflector installation on the first post. Use Type A reflectors unless shown otherwise on the plans.
7. Do not galvanize contact surfaces between the splice plate and the interior HSS tube surface.

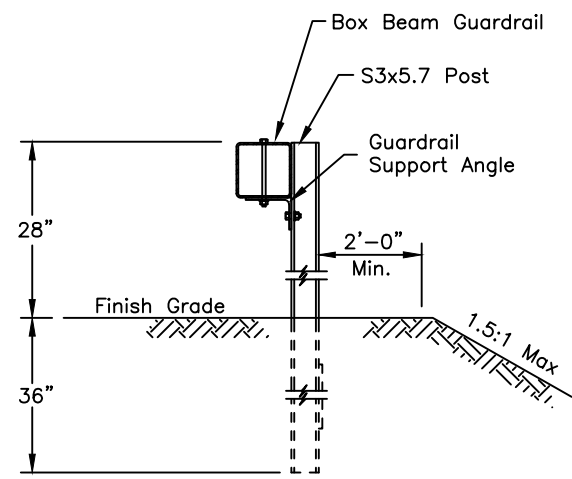

POST INSTALLATION

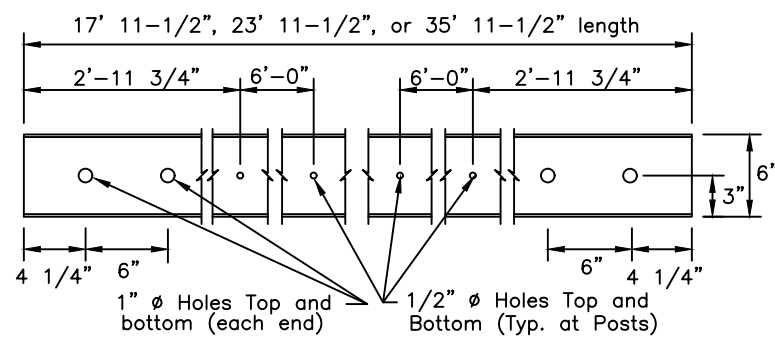
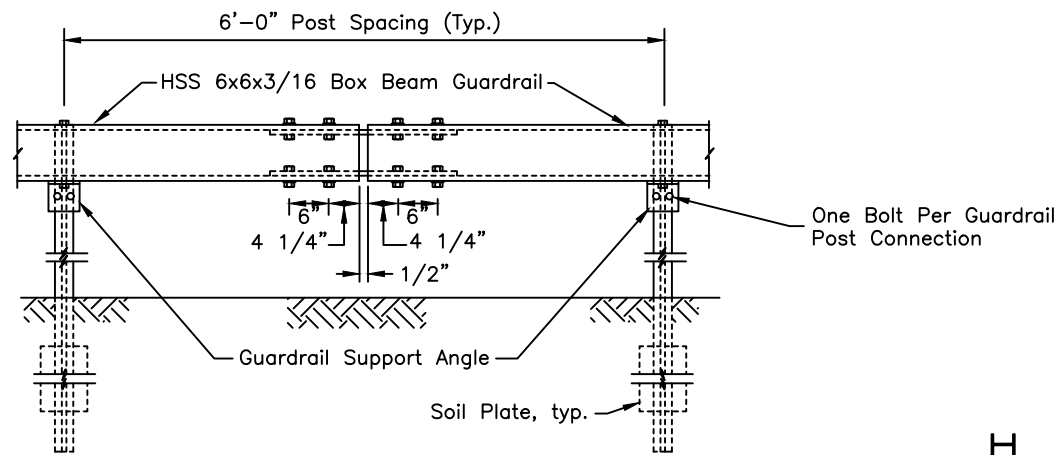

HSS 6x6 x 3/16 BOX BEAM GUARDRAIL

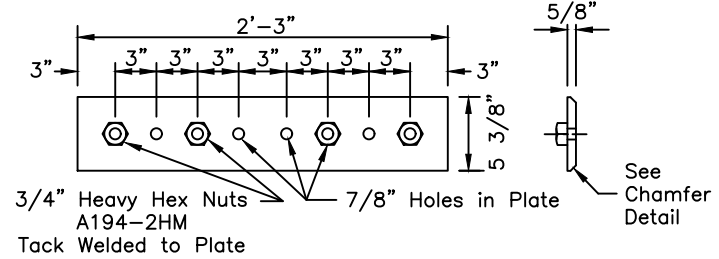

SPLICE PLATE

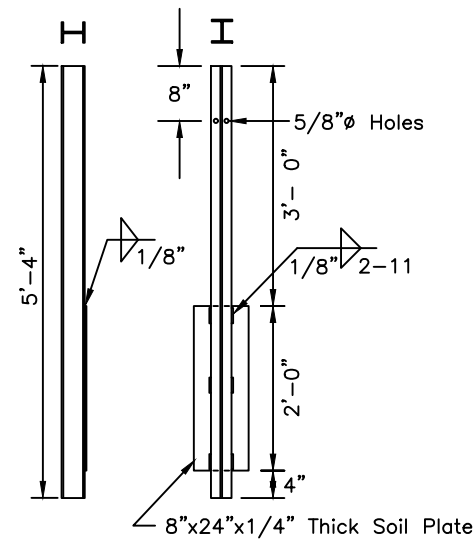

S3x5.7 BOX BEAM GUARDRAIL POST

ASTM A992 Post, ASTM A36 Plate

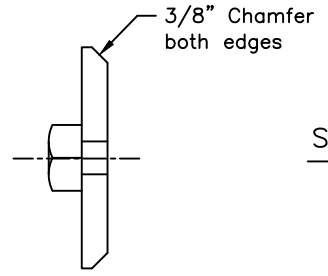

CHAMFER DETAIL

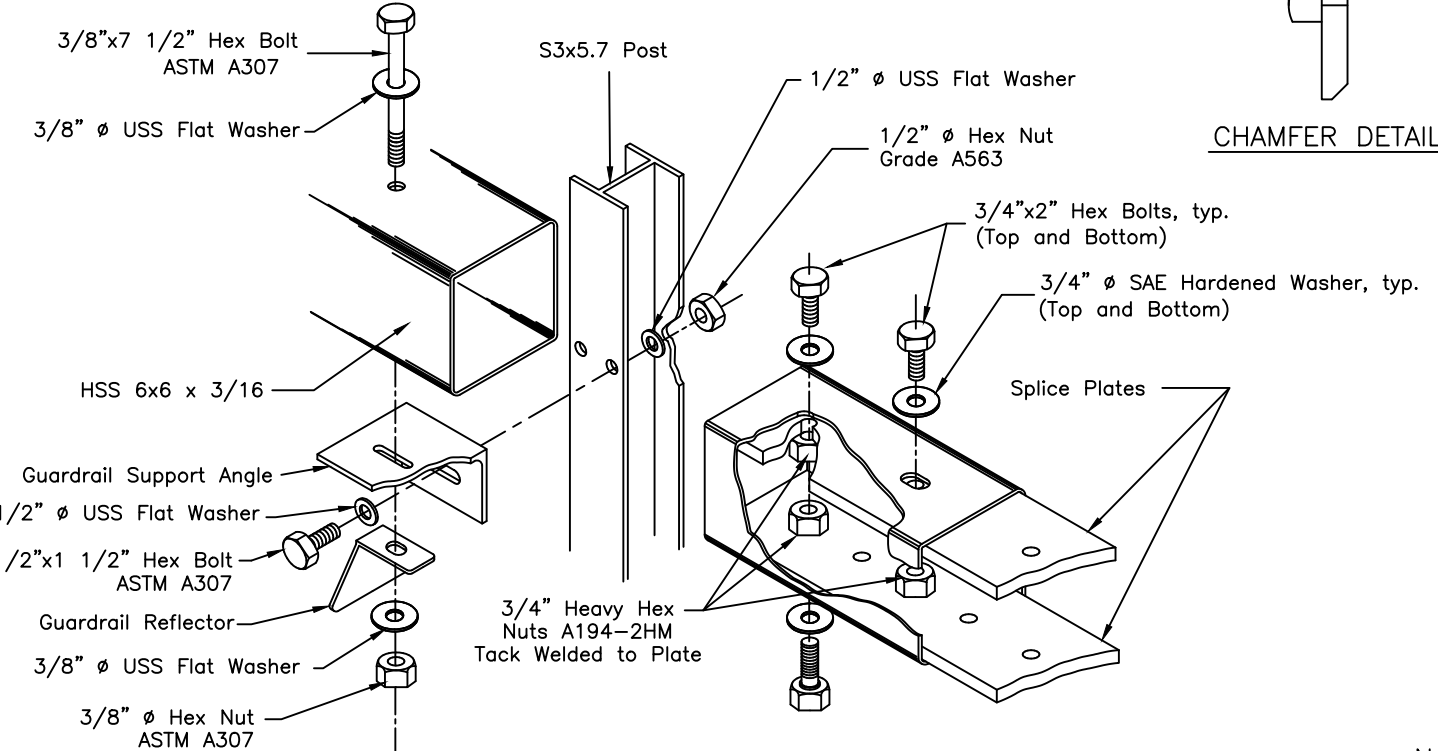

ASSEMBLY DETAIL

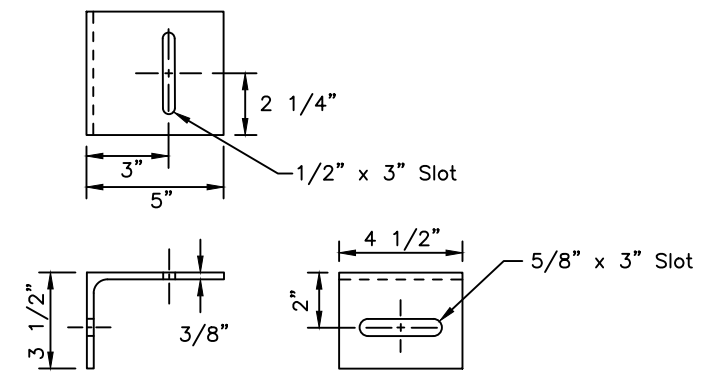

GUARDRAIL SUPPORT ANGLE

L 5 x 3.5 x 3/8 - ASTM A36

Note: Drawing not to scale

State of Alaska DOT&PF
ALASKA STANDARD PLAN

MASH BOX BEAM GUARDRAIL

Adopted as an Alaska Standard Plan by: *Carolyn Morehouse*
Carolyn Morehouse, P.E.
Chief Engineer

Adoption Date: 07/30/2021

Last Code and Stds. Review
By: LRG Date: 07/30/2021

Next Code and Standards Review date: 7/30/2021

G-04.00

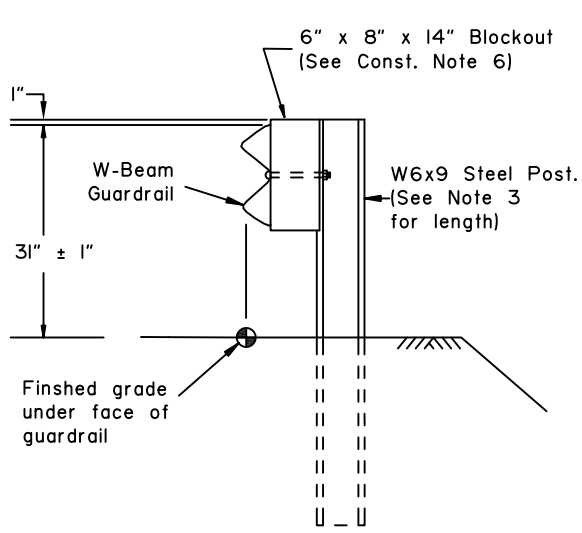

TYPE I POST INSTALLATION

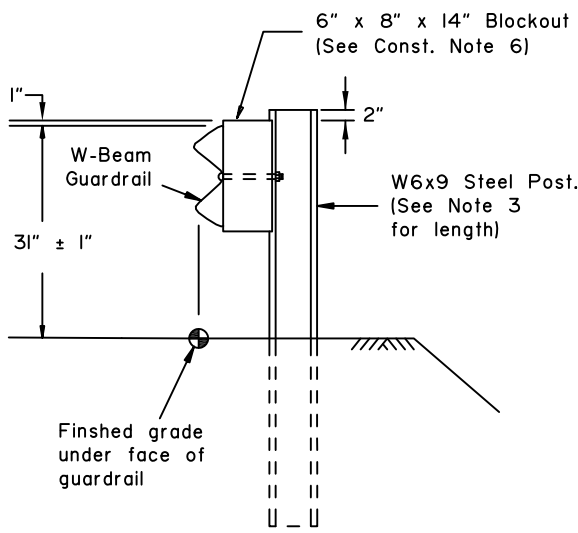

TYPE II POST INSTALLATION

(Facilitates raising rail for future overlays.)

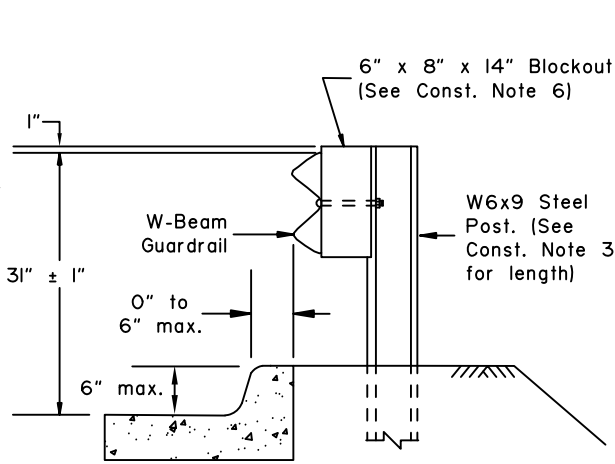

TYPE III POST INSTALLATION

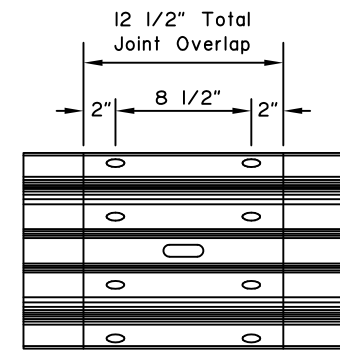

SPLICE DETAIL

(At mid span between posts only. Bolts not shown for clarity)

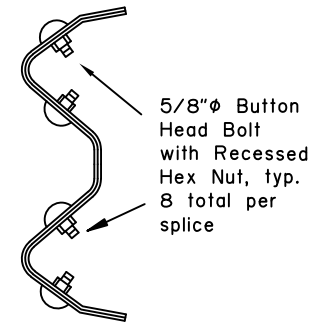

SPLICE CROSS-SECTION

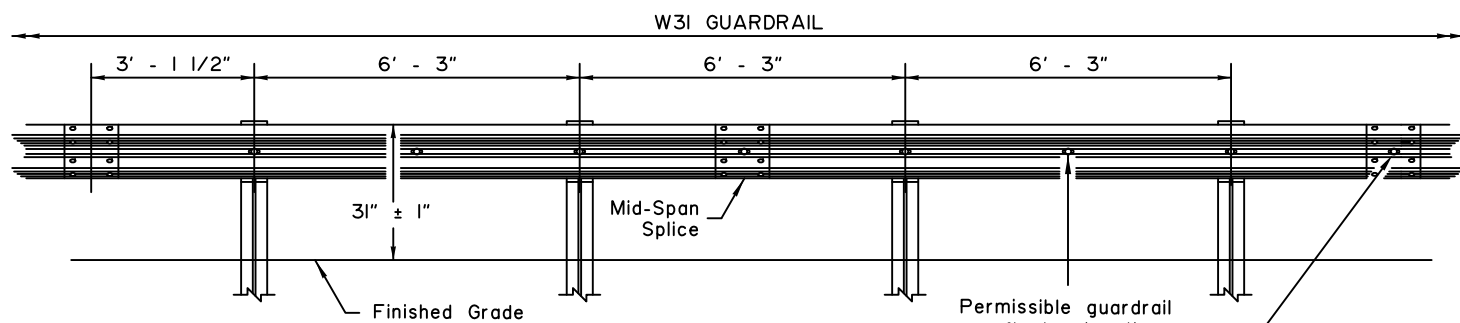

TYPICAL ELEVATION

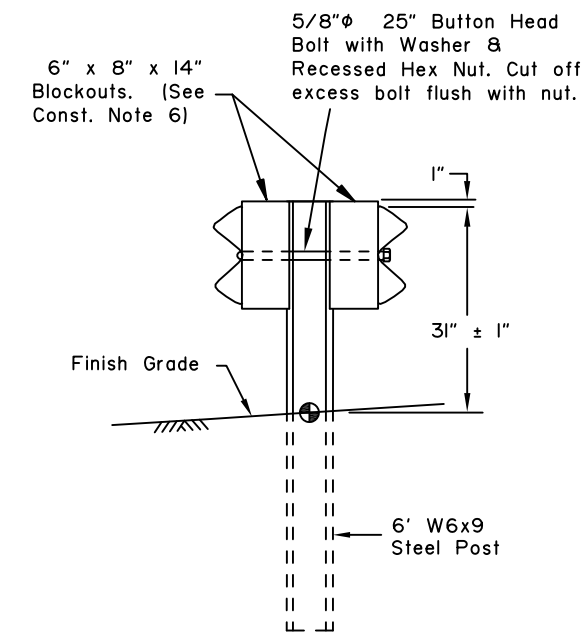

TYPE IV DOUBLE SIDED INSTALLATION

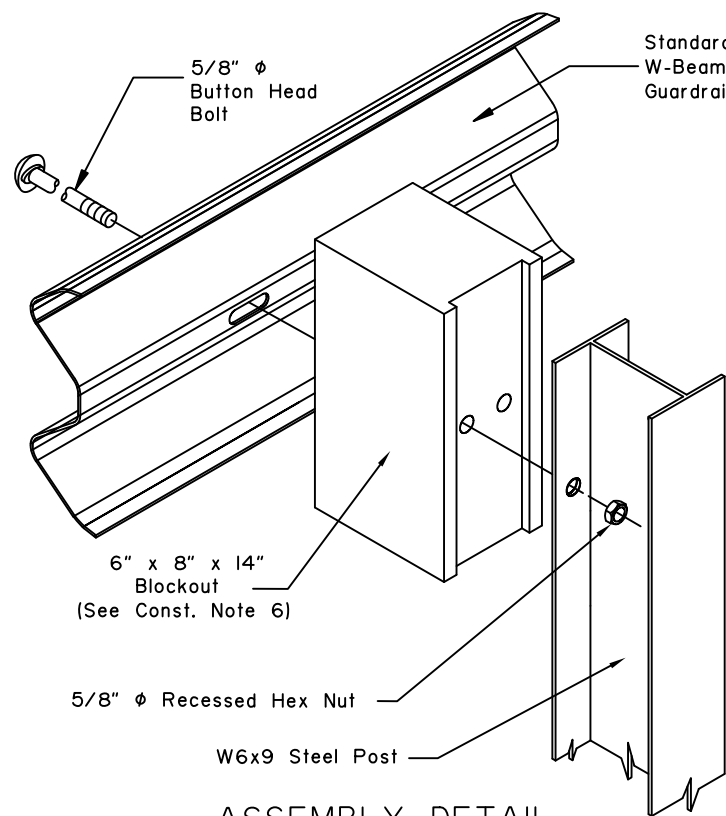

ASSEMBLY DETAIL

(Type I post shown)

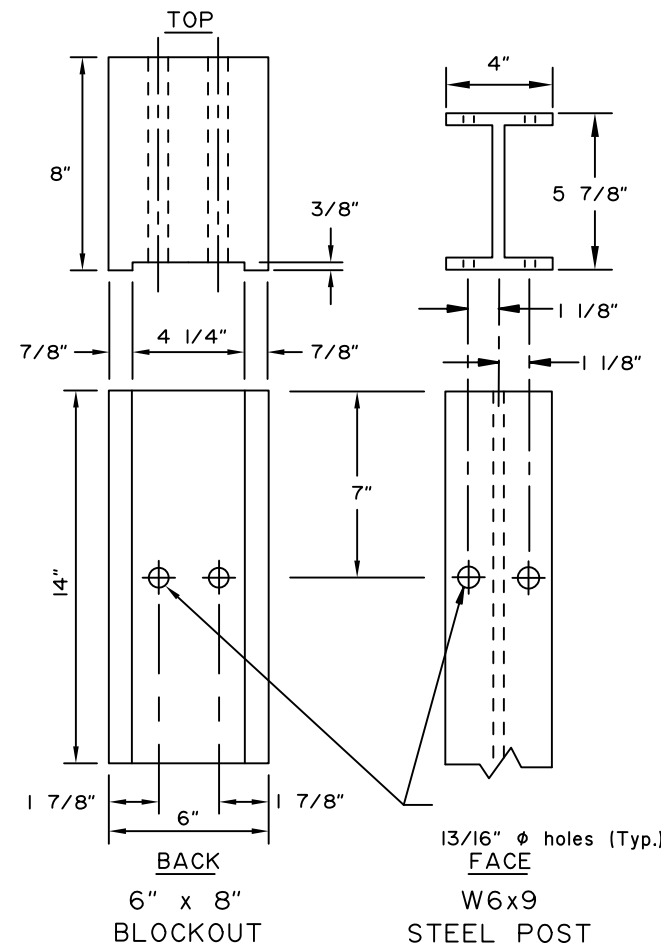

CONSTRUCTION NOTES:

1. Provide hardware compliant with the Task Force 13 (TF13) Guide to Standardized Roadside Safety Hardware.
2. See Standard Plan G-00 for hardware details not shown on this drawing.
3. See Standard Plan G-10 for post lengths corresponding to different combinations of slope and behind-post embankment width.
4. Typical post spacing is 6'-3" center to center.
5. Attach guardrail reflector to guardrail using a 5/8" button head bolt with 5/8" recessed head hex nut and steel washer at location shown in the Typical Elevation. Install reflectors every 25' on tangents and every 12.5' on curves starting 100' before the P.C. and ending 100' after the P.T.
6. Use wood or synthetic blockouts designed, tested, and passed per MASH for use with steel posts. Either bolt hole on the blockout may be used for attachment.
7. Use a 25 linear foot transition to match differing height of existing or new rail elements and end treatments - see Standard Plan G-II.
8. W6x8.5 steel post may be substituted for W6x9 steel post.
9. Install flexible delineators on guardrail posts when called for in the contract. See Standard Plan G-00 for guardrail flexible delineator details.

DESIGN NOTES:

1. No fixed objects allowed within 36" of the back side of guardrail post.
2. This barrier is acceptable under MASH Tests 3-10 and 3-11.

State of Alaska DOT&PF
ALASKA STANDARD PLAN
STEEL POST W31
GUARDRAIL

Adopted as an Alaska Standard Plan by: *Carolyn Morehouse*

Carolyn Morehouse, P.E.
Chief Engineer

Adoption Date: 05/15/2019

Last Code and Stds. Review
By: LRG Date: 5/15/2019

Next Code and Standards Review date: 5/15/2029

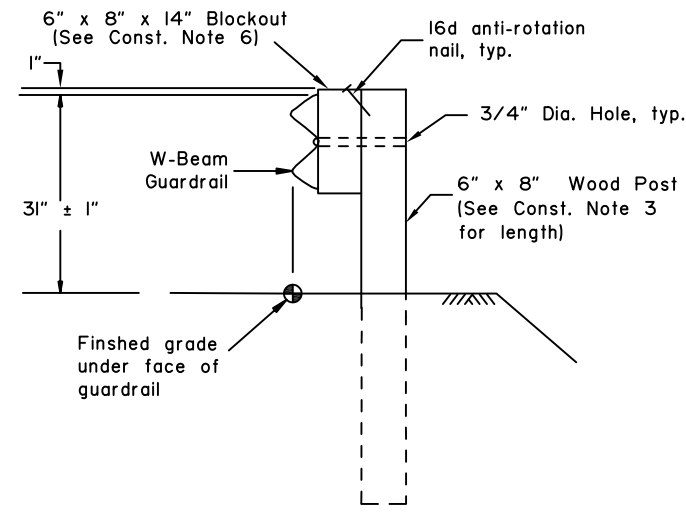

TYPE I POST INSTALLATION

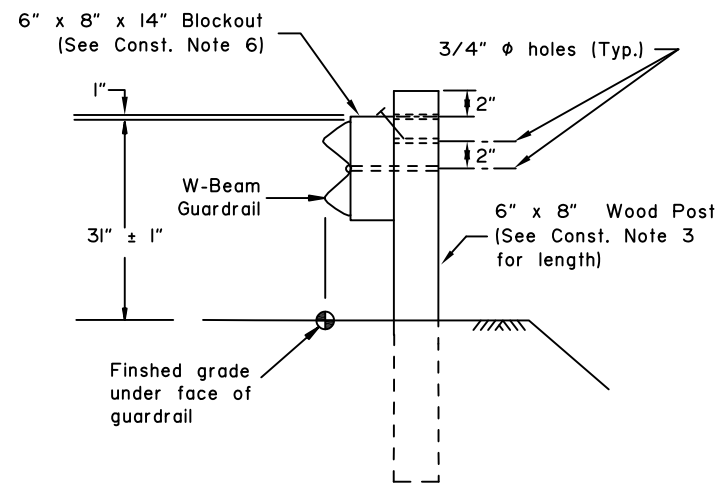

TYPE II POST INSTALLATION

(Facilitates raising rail for future overlays.)

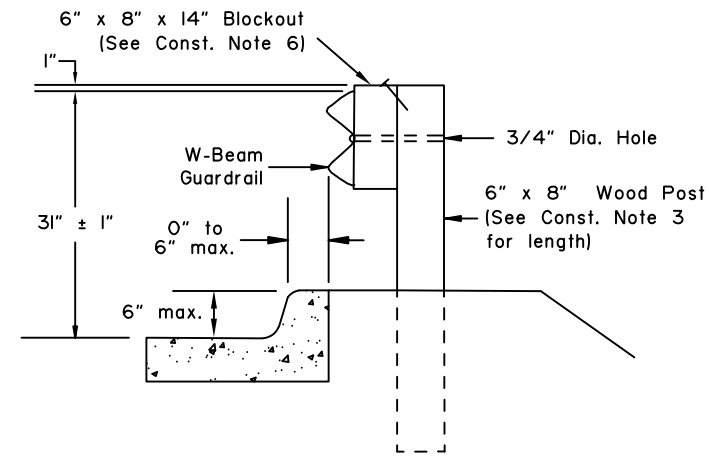

TYPE III POST INSTALLATION

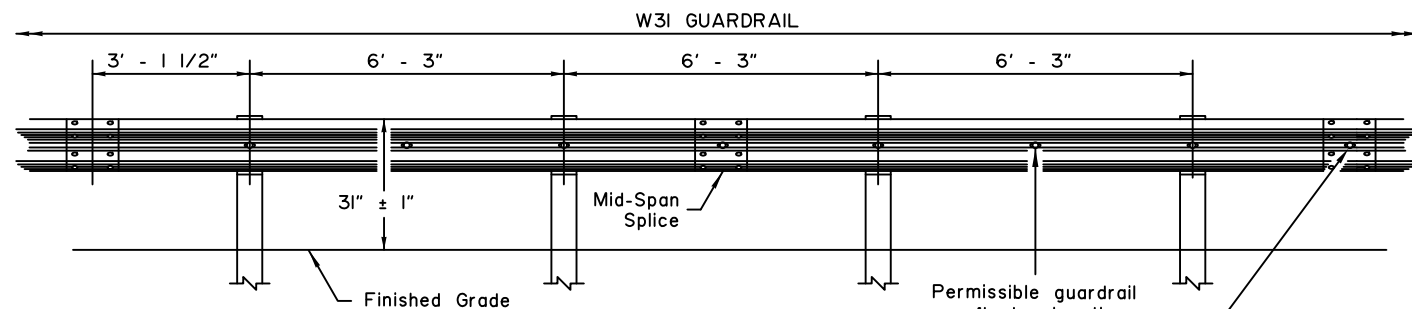

TYPICAL ELEVATION

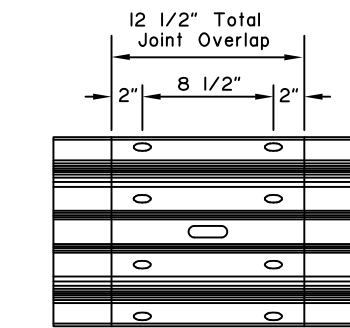

SPLICE DETAIL

(At mid-span between posts only. Bolts not shown for clarity.)

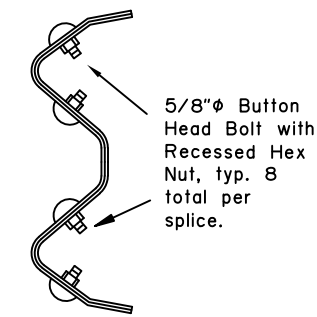

SPLICE CROSS-SECTION

CONSTRUCTION NOTES:

1. Provide hardware compliant with the Task Force 13 (TF13) Guide to Standardized Roadside Safety Hardware.
2. See Standard Plan G-00 for hardware details.
3. See Standard Plan G-10 for post lengths corresponding to different combinations of slope and behind-post embankment width.
4. Typical post spacing is 6'-3" center to center.
5. Attach guardrail reflector using a 5/8" button head bolt with 5/8" recessed head hex nut and steel washer at the location shown on the Typical Elevation. Install reflectors every 25' on tangents and every 12.5' on curves starting 100' before the P.C. and ending 100' after the P.T.
6. Use wood blockouts designed, tested, and passed per MASH to be used with wood posts.
7. Use 25 linear foot transition panel to match differing height of existing or new rail elements and end treatments. See Standard Plan G-11.
8. Install flexible delineators on guardrail posts when called for in the contract. See Standard Plan G-00 for guardrail flexible delineator details.

DESIGN NOTES:

1. No fixed objects allowed within 36" of the back side of guardrail post.
2. This barrier is acceptable under MASH tests 3-10 and 3-11.

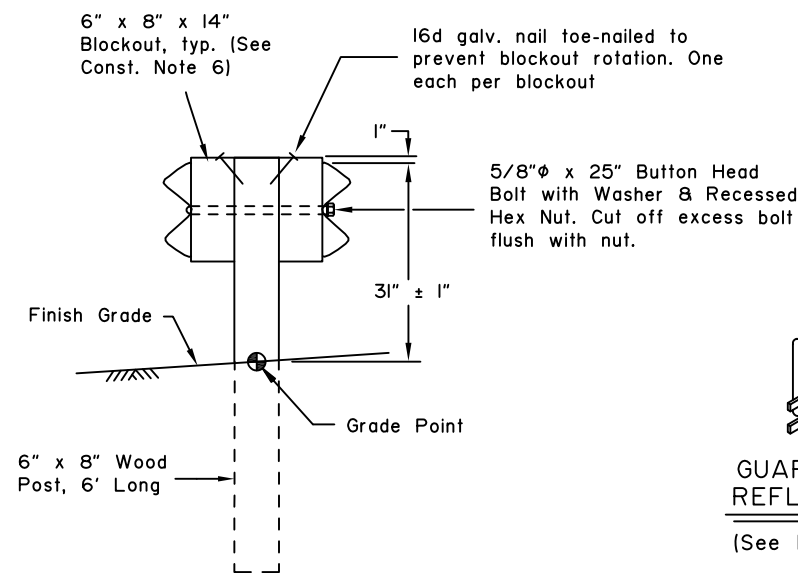

TYPE IV DOUBLE SIDED INSTALLATION



GUARDRAIL REFLECTOR
(See Note 5)

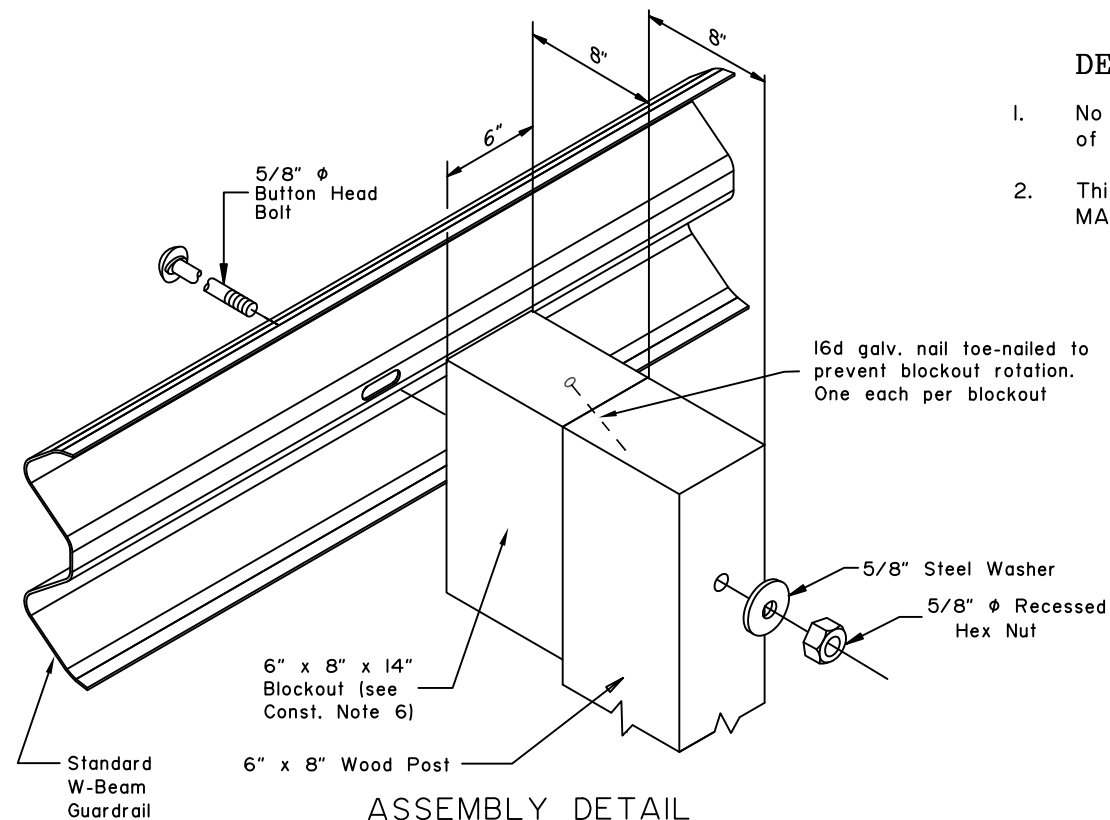

ASSEMBLY DETAIL

(Type I post shown)

State of Alaska DOT&PF
ALASKA STANDARD PLAN
WOOD POST W31
GUARDRAIL
Carolyn Morehouse
Adopted as an Alaska
Standard Plan By: _____
Carolyn Morehouse, P.E.
Chief Engineer
Adoption Date: 05/10/2019
Last Code and Stds. Review
By: _____ Date: _____
Next Code and Standards Review date: 05/10/2029

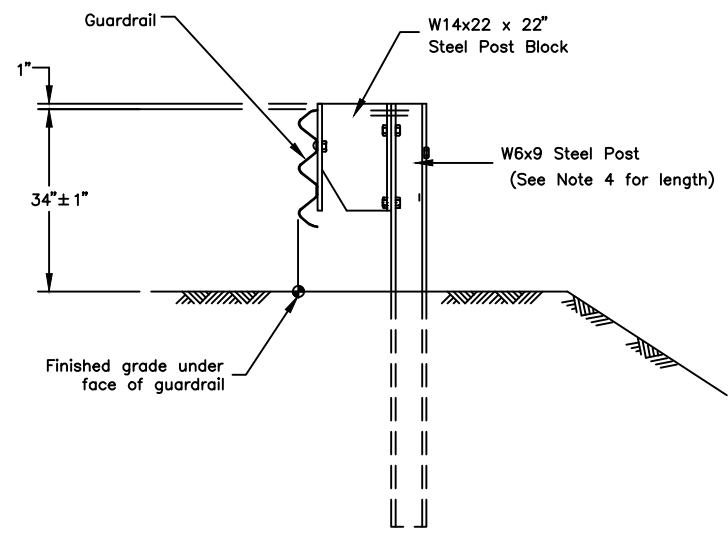

TYPE I POST INSTALLATION

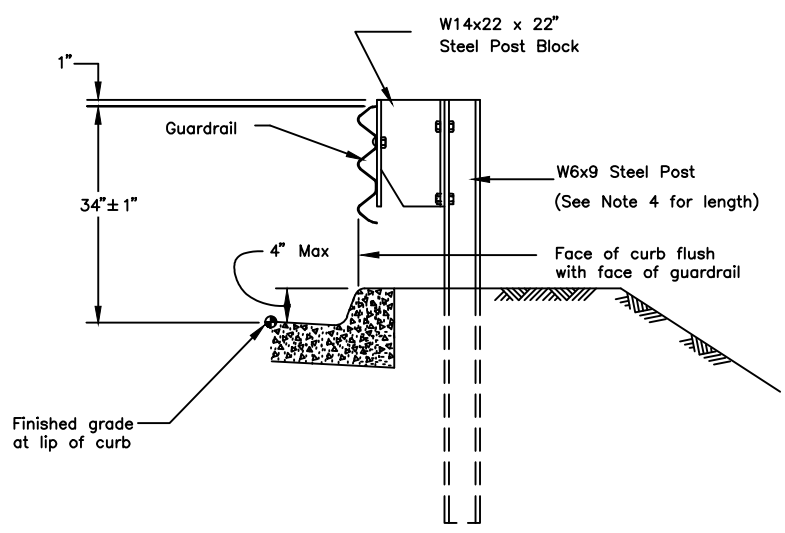

CURB DETAIL
TYPE III POST INSTALLATION

GENERAL NOTES:

1. Attach guardrail reflector to rail panel using a 5/8" button head bolt with 5/8" recessed head hex nut and steel washer in a mid-span bolt slot in the upper indentation of the rail panel. Begin 37-1/2" from the first applicable guardrail post. Install reflectors every 25' on tangents and every 12.5' on curves starting 100' before the P.C. and ending 100' after the P.T. Type A reflectors shall be used unless specified otherwise on the plans.
2. All covered hardware shall comply with the Task Force 13 (TF 13) Guide to Standardized Roadside Safety Hardware online publication.
3. See Standard Plan G-00, "Standard Guardrail Hardware" for hardware details.
4. See Standard Plan G-10, "Beam Guardrail Post Installation" for post lengths corresponding to different combinations of slope and behind-post embankment width.
5. Mount rail to block with a bolt on the approaching-traffic side of block web.
6. Typical post spacing is 6'-3" center to center.
7. This barrier is acceptable under NCHRP 350, TL3 and TL4.
8. Furnish RTM04a-04b thrie-beam rail panels.

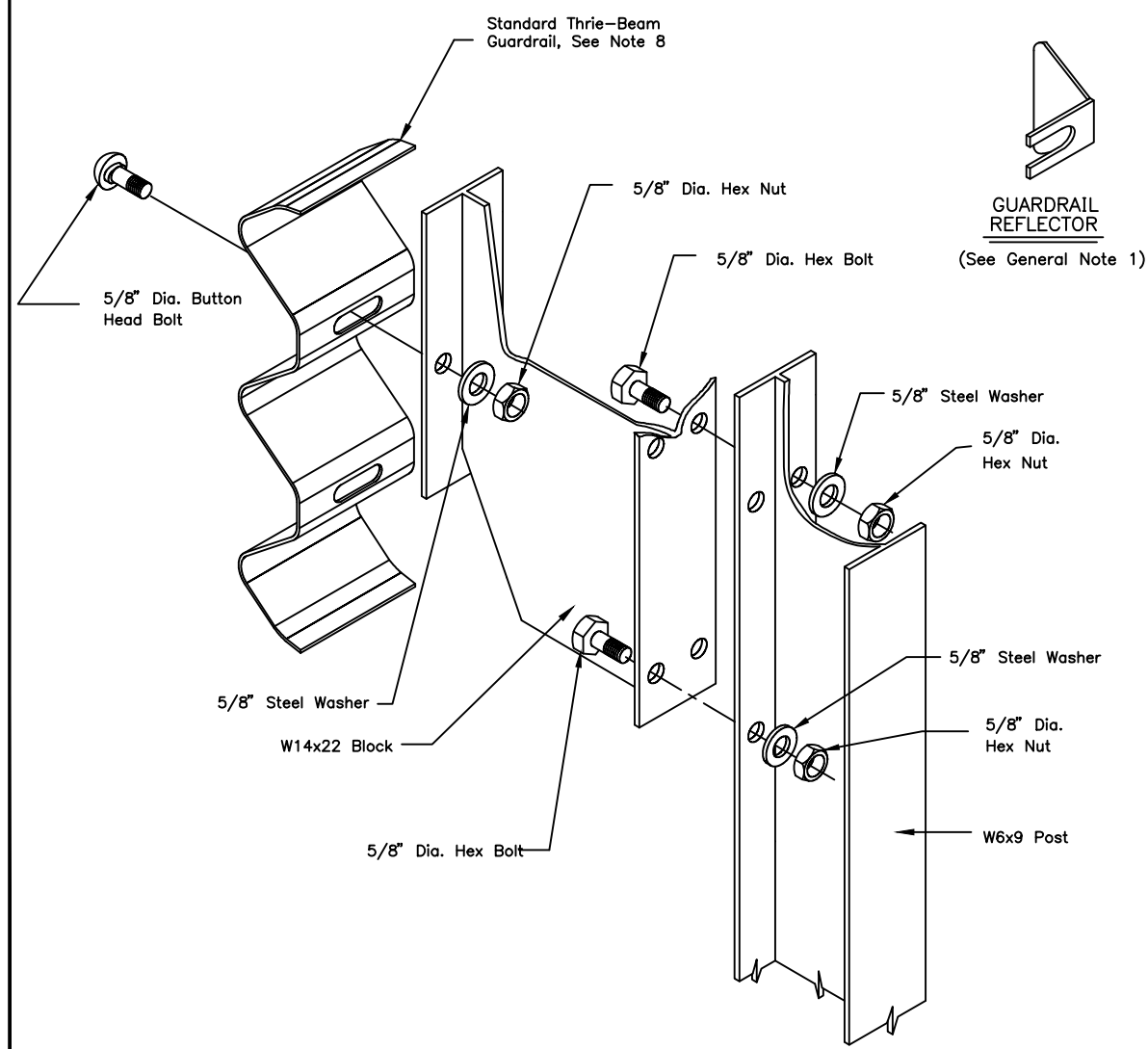

ASSEMBLY DETAIL

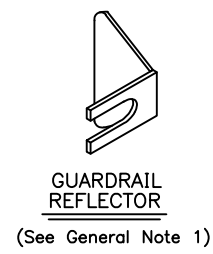

GUARDRAIL REFLECTOR
(See General Note 1)

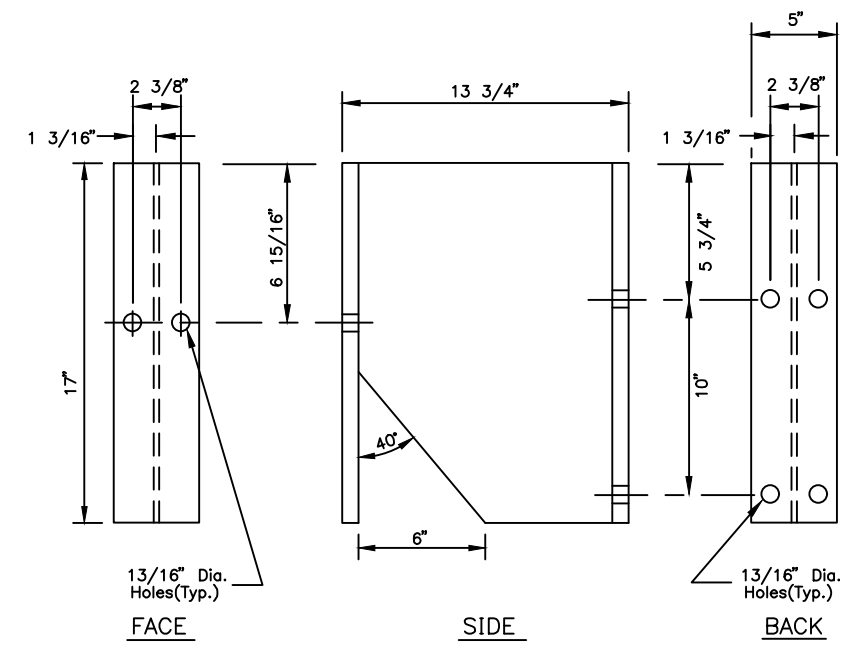

W14x22 POST BLOCK

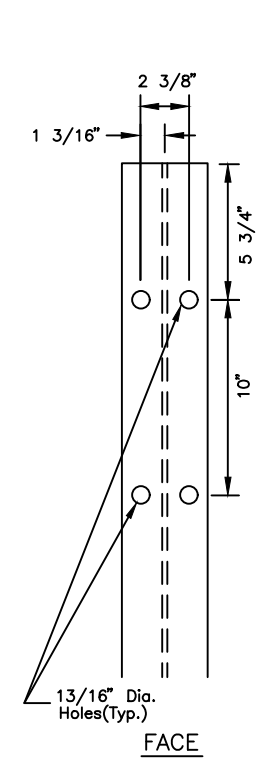

W6x9 STEEL POST

State of Alaska DOT&PF
ALASKA STANDARD PLAN
STEEL POST MODIFIED
THRIE-BEAM
GUARDRAIL

Adopted as an Alaska Standard Plan by: *Carolyn Morehouse*
Carolyn Morehouse, P.E.
Chief Engineer

Adoption Date: 7/17/2020

Last Code and Stds. Review
By: KLK Date: 7/8/2020
Next Code and Standards Review Date: 7/8/2030

G-09.05S

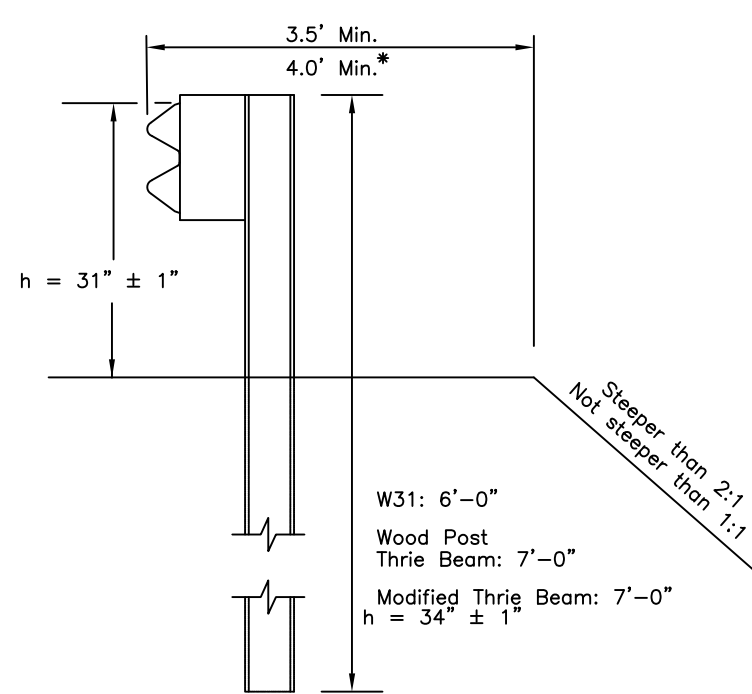

CASE 1

* with Modified Thrie Beam

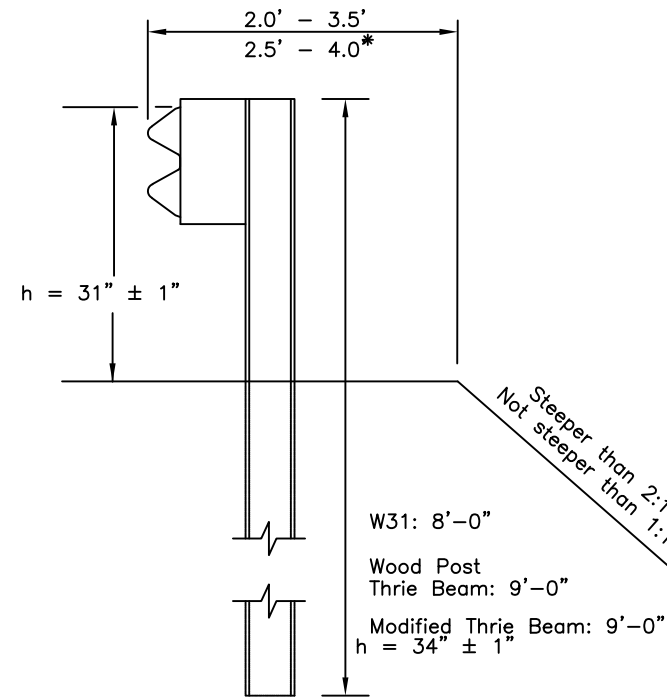

CASE 2

* with Modified Thrie Beam

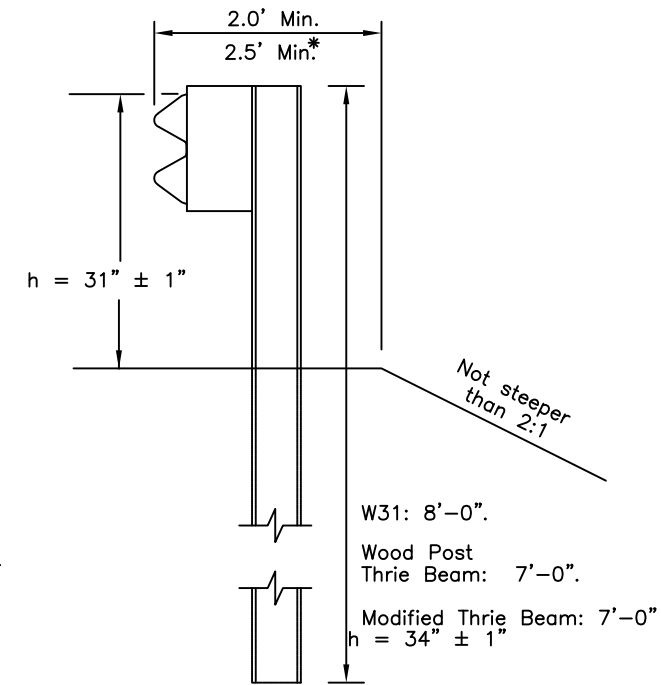

CASE 3

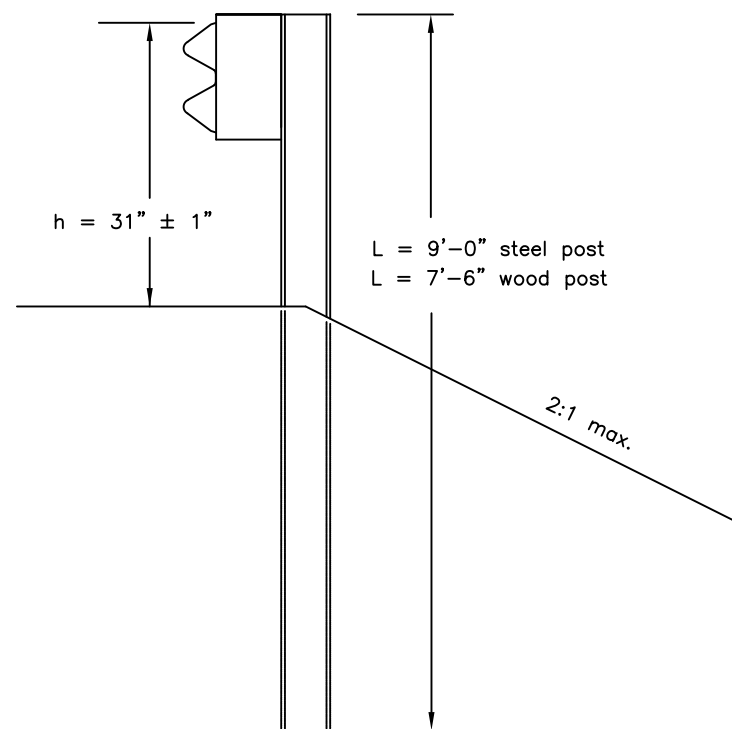

CASE 4

(See Note 5)

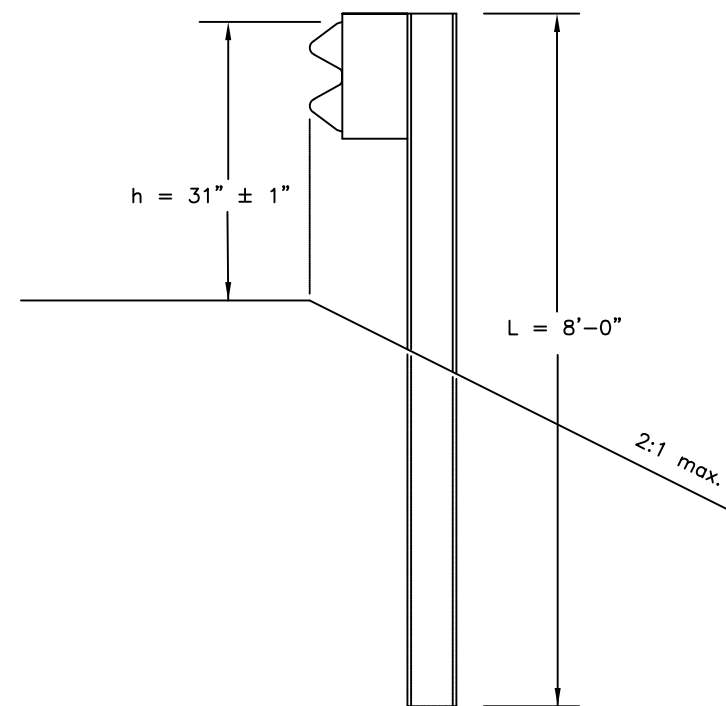

CASE 5

(See Note 5)

CONSTRUCTION NOTES:

1. This drawings is to be used for post length determination only. See Plans for slopes and behind-post embankment widths.
2. To determine post length, identify the case that matches site conditions and read the length corresponding to the pertinent guardrail type.
3. These dimensions apply to both curbed and uncurbed section.
4. Case 1, 2 and 3 are shown with steel posts. Wood posts may be substituted when allowed by specifications. Wood Post Thrie Beam installations must use wood posts only.
5. Case 4 and 5 apply to W31 guardrail only.

DESIGN NOTES:

1. No fixed objects allowed within 48" of the back of post for Cases 1, 2, 3, 4, and 5.

State of Alaska DOT&PF
ALASKA STANDARD PLAN

GUARDRAIL POST
INSTALLATION

Adopted as an Alaska Standard Plan by: *Carolyn H Morehouse*

Carolyn Morehouse, P.E.
Chief Engineer

Adoption Date: 09/15/2022

Last Code and Stds. Review
By: LRG Date: 09/15/2022

Next Code and Standards Review date:09/15/2032

GENERAL NOTES:

1. This drawing illustrates steel post W31 guardrail. Wood posts may be used where noted as applicable to the project.

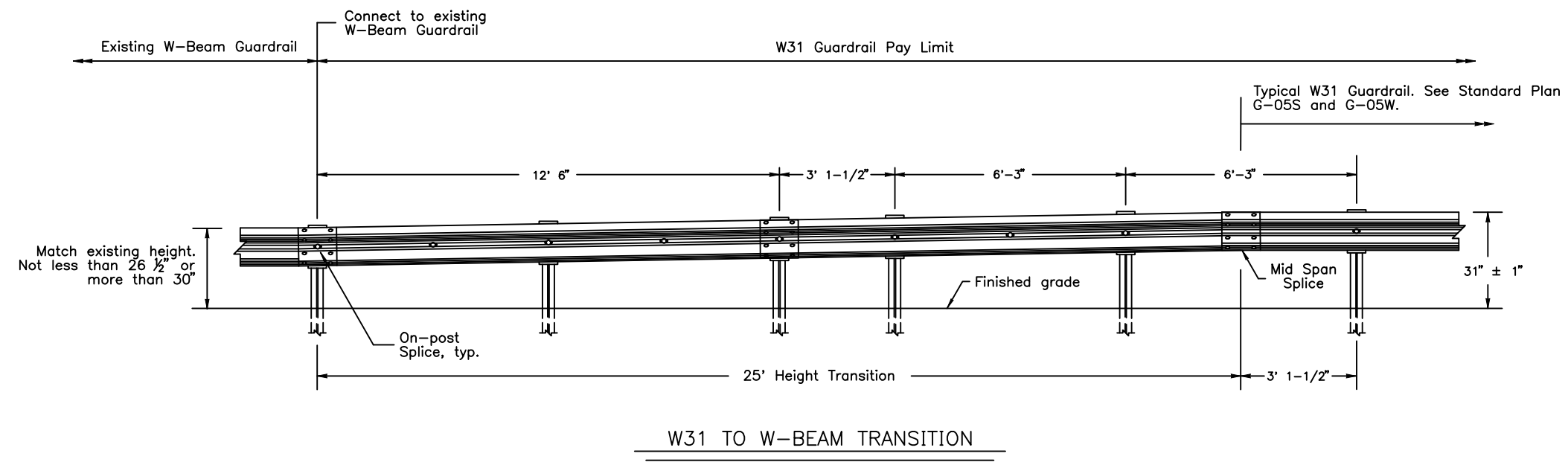

State of Alaska DOT&PF
ALASKA STANDARD PLAN

**W31 GUARDRAIL
TRANSITION DETAILS**

Adopted as an Alaska Standard Plan by: *Carolyn Morehouse*
Carolyn Morehouse, P.E.
Chief Engineer

Adoption Date: 7/17/2020

Last Code and Stds. Review
By: KLK Date: 7/8/2020
Next Code and Standards Review Date: 7/8/2030

G-11.01

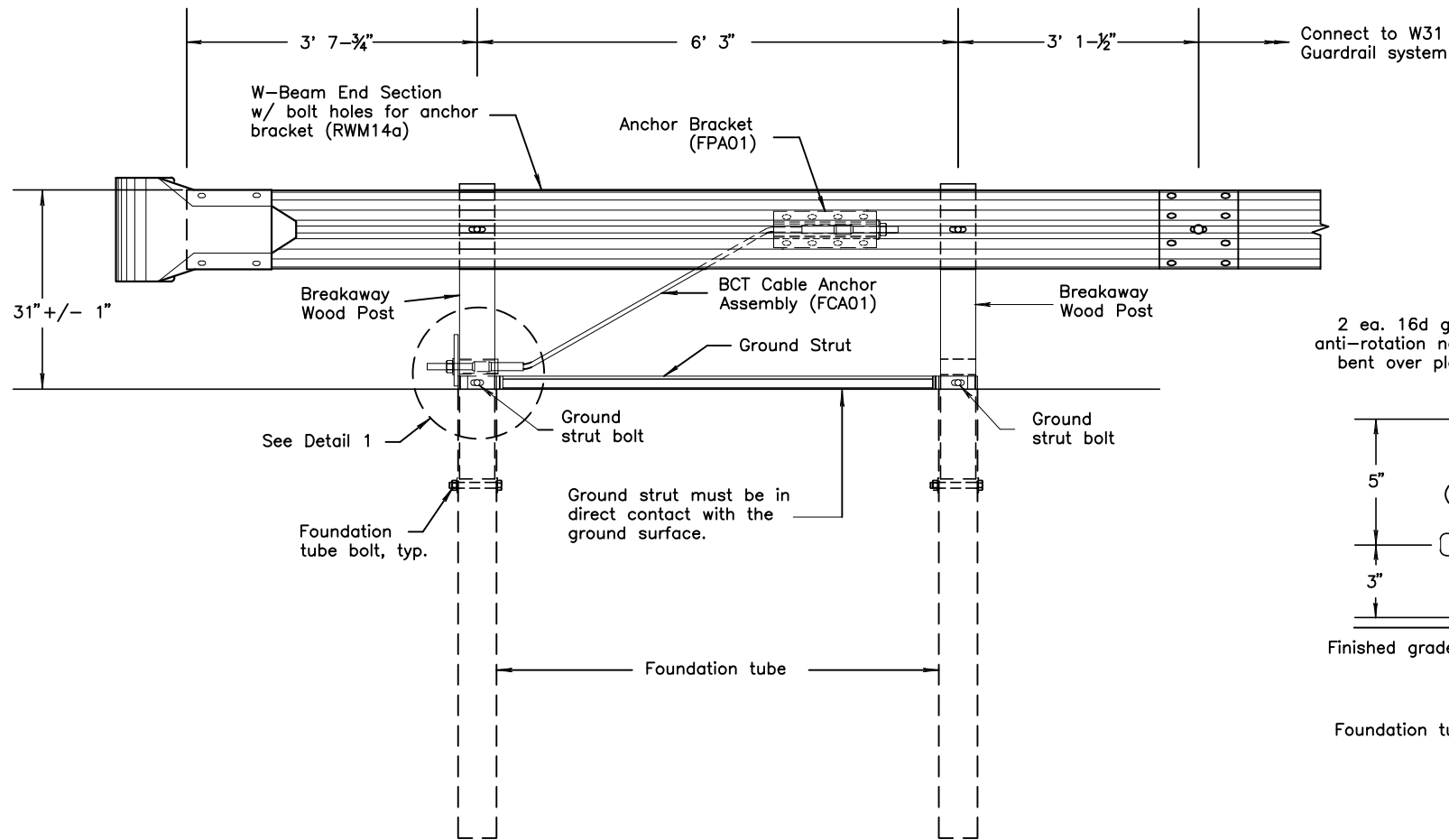

ELEVATION

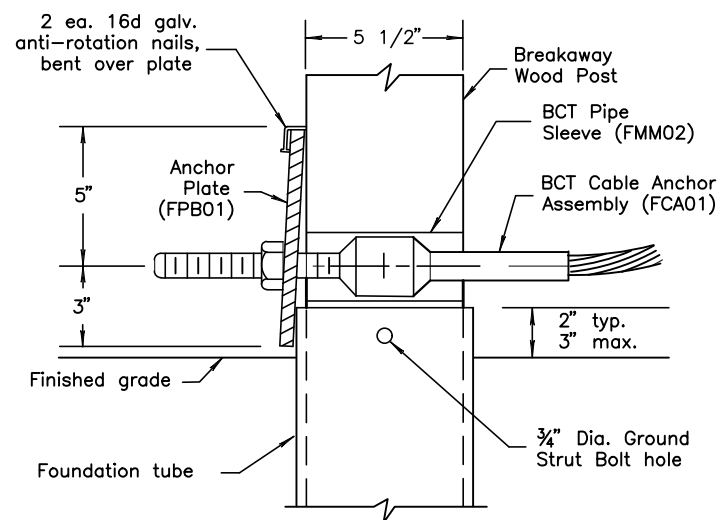

DETAIL 1

(Ground strut not shown for clarity)

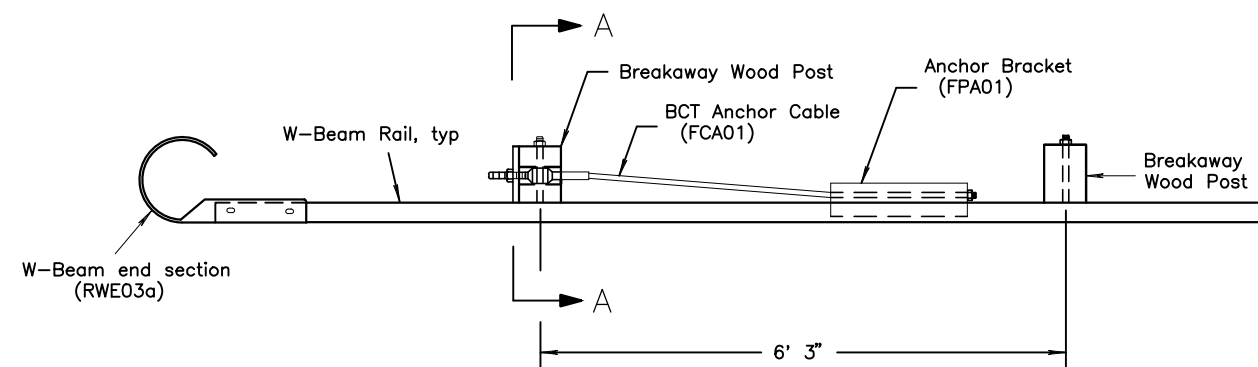

PLAN VIEW

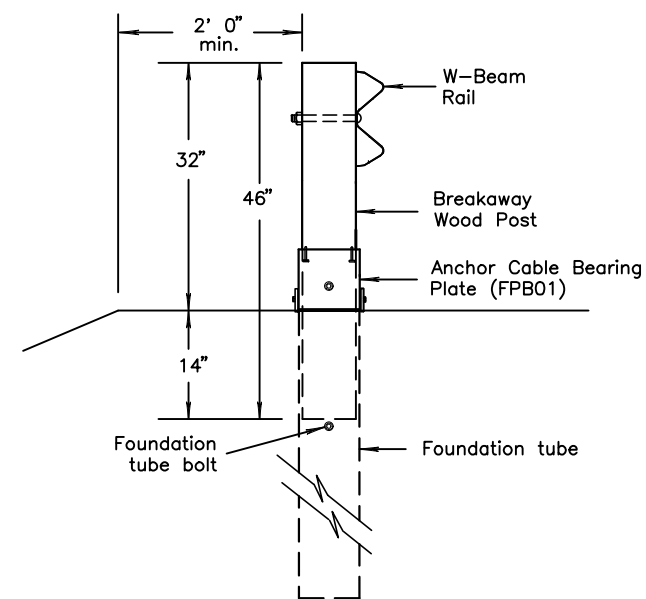

SECTION A-A

CONSTRUCTION NOTES

1. All covered hardware must comply with Task Force 13 (TF13) Guide to Standardized Roadside Safety Hardware online publication. Designators are given in parenthesis, when possible.
2. End section bolts and nuts have the same material requirements as splice bolts.
3. Foundation tube bolts are are 7/8" diameter ASTM A307 hex head. Foundation tube bolts require an ASTM A563 A nut and two ASTM F844 7/8" diameter flat washers. Install one washer under bolt head and one under nut.
4. Anchor bracket and strut bolts are are 5/8" diameter ASTM A307 hex head. Foundation tube bolts require ASTM A563 A nut and two ASTM F844 7/8" diameter flat washers. Install one washer under bolt head and one under nut.

State of Alaska DOT&PF
ALASKA STANDARD PLAN

W31 DOWNSTREAM
END ANCHOR

Adopted as an Alaska Standard Plan by: *Carolyn Morehouse*
Carolyn Morehouse, P.E.
Chief Engineer

Adoption Date: 7/17/2020

Last Code and Stds. Review
By: KLK Date: 7/8/2020

Next Code and Standards Review Date: 7/8/2030

G-14.01

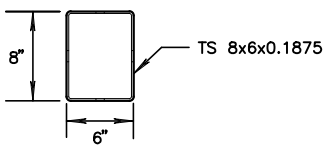

PLAN VIEW

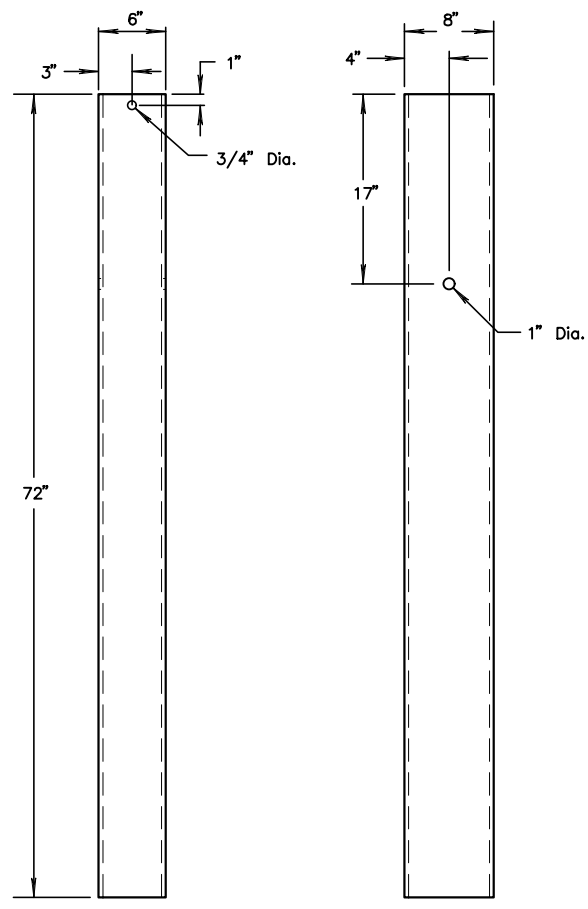

FRONT VIEW

SIDE VIEW

FOUNDATION TUBE

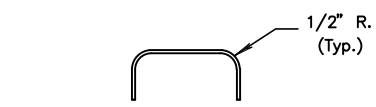

GROUND STRUT SECTION

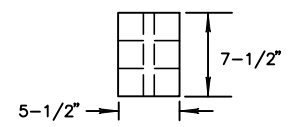

PLAN VIEW

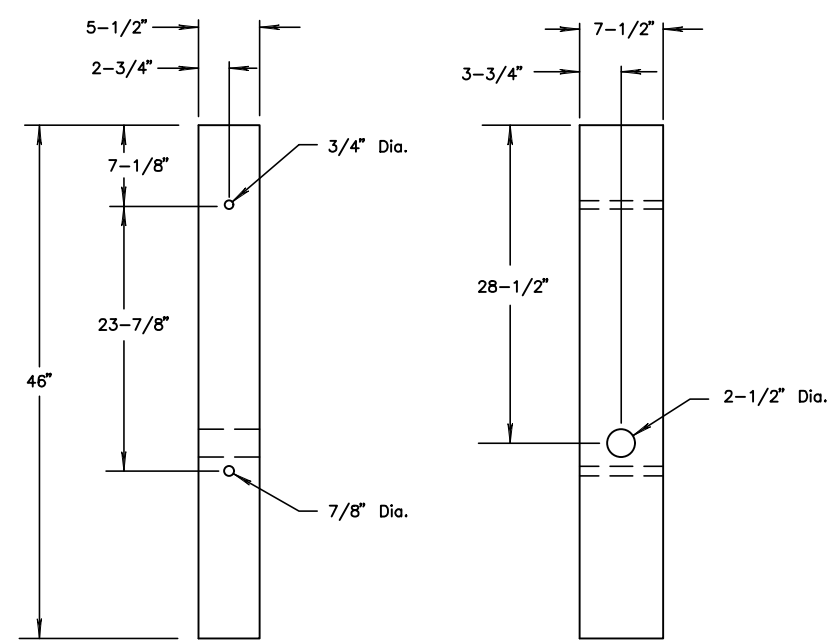

FRONT VIEW

SIDE VIEW

BREAKAWAY WOOD POST

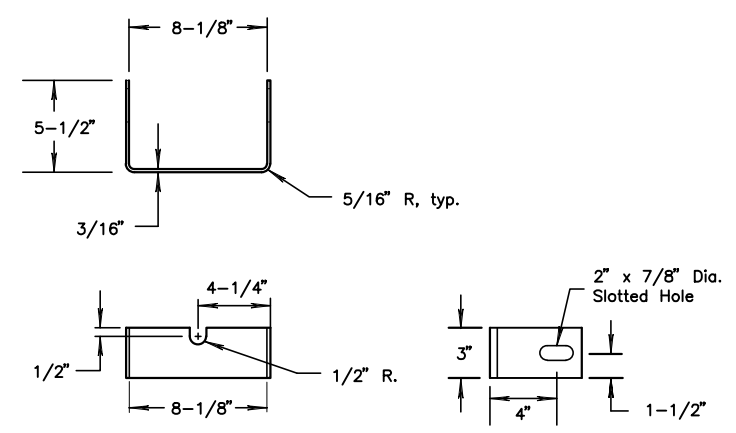

YOKE DETAIL

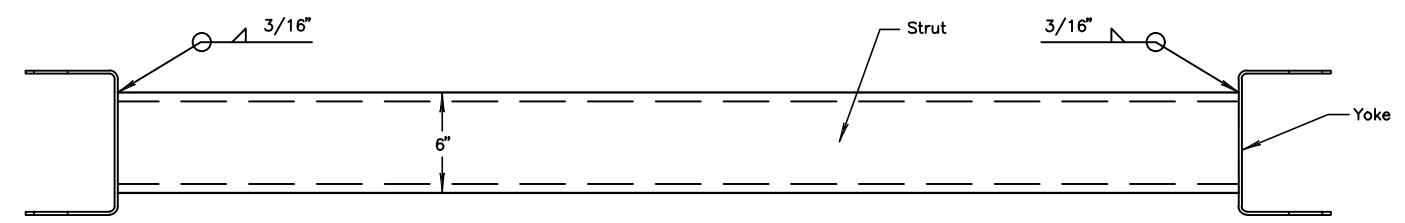

PLAN VIEW

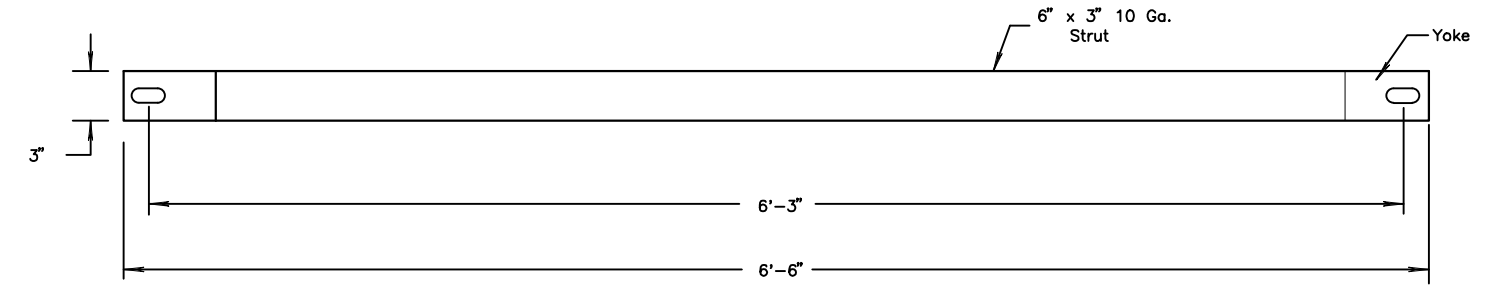

FRONT VIEW

GROUND STRUT DETAIL

CONSTRUCTION NOTES

- All covered hardware must comply with Task Force 13 (TF13) Guide to Standardized Roadside Safety Hardware online publication. Designators are given in parenthesis, when possible.

State of Alaska DOT&PF
ALASKA STANDARD PLAN

W31 DOWNSTREAM
END ANCHOR

Adopted as an Alaska Standard Plan by: *Carolyn Morehouse*
Carolyn Morehouse, P.E.
Chief Engineer

Adoption Date: 7/17/2020

Last Code and Stds. Review
By: KLK Date: 7/8/2020

Next Code and Standards Review Date: 7/8/2030

G-14.01

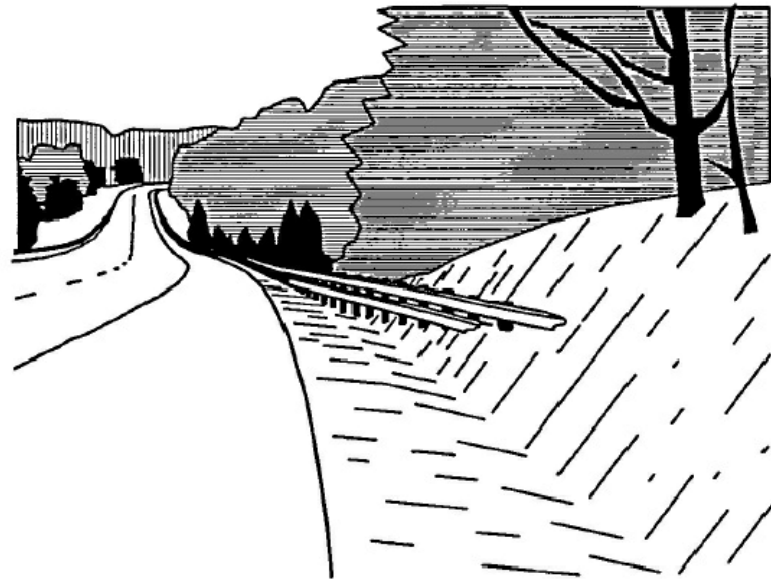

PERSPECTIVE VIEW

LATERAL OFFSET TABLE	
Post No.	Offset*
A	14' 3"
D	11' 2-1/4"
E	9' 1-1/2"
F	6' 0-1/4"
I	3'-1/4"

* Lateral offset is measured from the shoulder hinge point line to the back of guardrail. These offsets apply only for the foreslope and backslope conditions shown on the Sections on Sheet 2. For other foreslope or backslope conditions, these offsets need to be recomputed.

FLARE RATE TABLE	
Posts	Flare Rate
A - D	4 : 1
D - E	6 : 1
E - F	8 : 1
F - I	13 : 1
I - J	13:1 or flatter

CONSTRUCTION NOTES:

1. W-beam, blockout, and post details not shown here shall conform to Std Dwg G-05S.
2. All covered hardware shall comply with the Task Force 13 (TF13) Guide to Standardized Roadside Safety Hardware online publication.
3. This terminal is MASH TL-3 tested.
4. Pay limits for Buried-in-Backslope Terminal are from Post A to Post I. Payment for Buried-in-Backslope Terminal includes excavation and backfill work associated with burial from Post A to Post I.
5. Extend the W31 guardrail at a 13:1, or flatter, flare rate from Post I to Post J, where the typical guardrail run is parallel to the shoulder. Field bend w-beam rail element to transition from the 13:1 flare to parallel to the shoulder at Post J.
6. Provide a 20' x 75' object free area when backslopes are flatter than 2:1. When required, this work is subsidiary to the Buried-in-Backslope Terminal.

Provide 20' x 75' area free of fixed object hazards behind guardrail. Any signs or other highway appurtenances must be mounted on breakaway supports. See Construction Note 6.

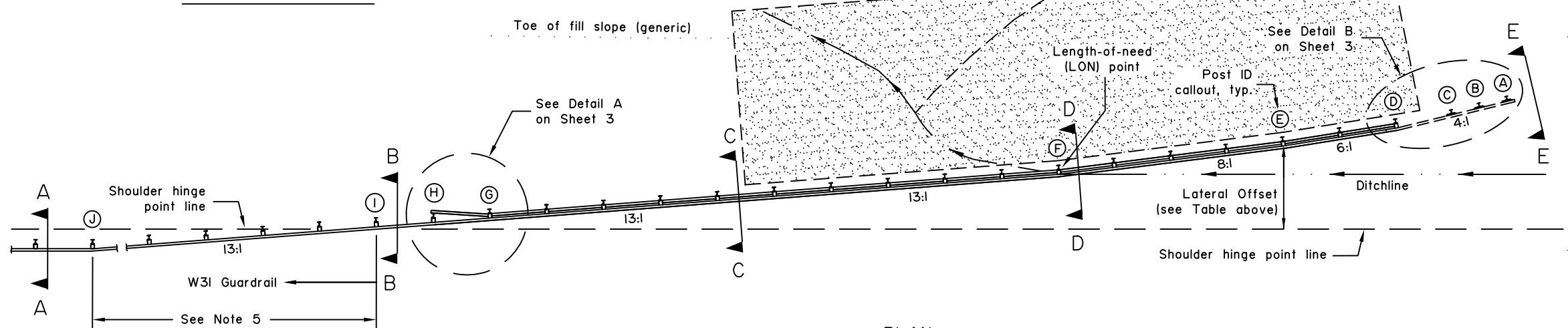

PLAN

All sections in this plan view are shown on Sheet 2

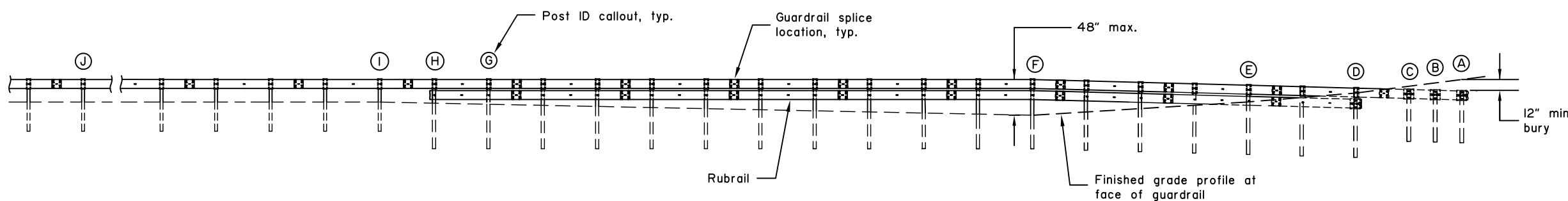

ELEVATION

DESIGN NOTES:

1. The LON point shown on this sheet is for the conditions shown in the Sections on Sheet 2. For other foreslope conditions, especially those with wider foreslopes and deeper ditches, the LON point will be at a different location. In this case, the LON point is where the top of the rail height first reaches 48" with respect to the finished grade at the face of the guardrail

State of Alaska DOT&PF
ALASKA STANDARD PLAN
W31 GUARDRAIL
BURIED-IN-BACKSLOPE
TERMINAL

Adopted as an Alaska Standard Plan by: *Kenneth J. Fisher*
Kenneth J. Fisher, P.E.
Chief Engineer

Adoption Date: 02/08/2019

Last Code and Stds. Review
By: Date:

Next Code and Standards Review date: 02/08/2029

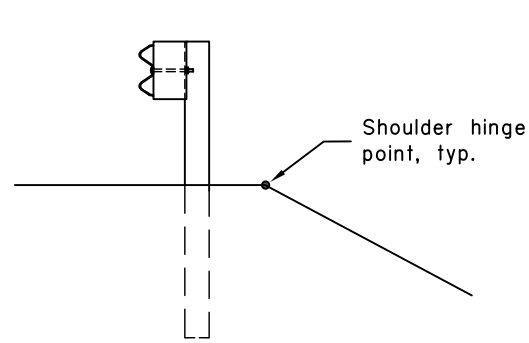

SECTION A-A
Typical Section of Guardrail
Installation at shoulder

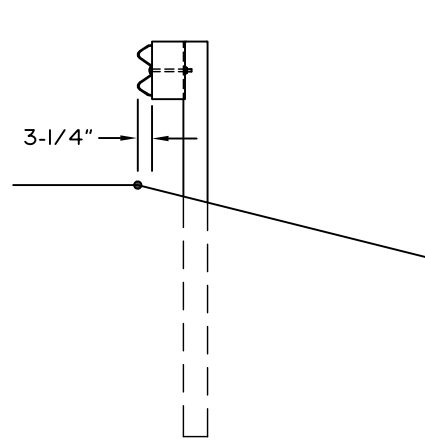

SECTION B-B
Typical Section at Post I.
Face of Guardrail flush with
shoulder hinge point.

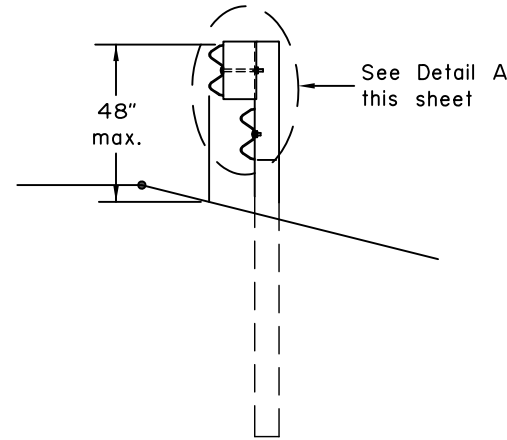

SECTION C-C
Guardrail on foreslope.

GENERAL NOTES:

1. W-beam, blackout, and post details not shown here shall conform to Std Dwg G-05S.
2. All covered hardware shall comply with the Task Force 13 (TF13) Guide to Standardized Roadside Safety Hardware online publication.
3. Foreslopes shall be 4:1 or flatter. Backslopes may be 1:1 maximum to 3:1 minimum. Lateral offsets shown on this sheet and Sheet 1 are based on the 4:1 foreslope, 2:1 backslope, and 18" ditch depth shown on this sheet. Other ditch depth, foreslope, or backslope conditions will require recomputation of lateral offsets and special grading of the top of guardrail to maintain the 48" maximum ground clearance to the top of guardrail and 12" minimum bury at Post A.

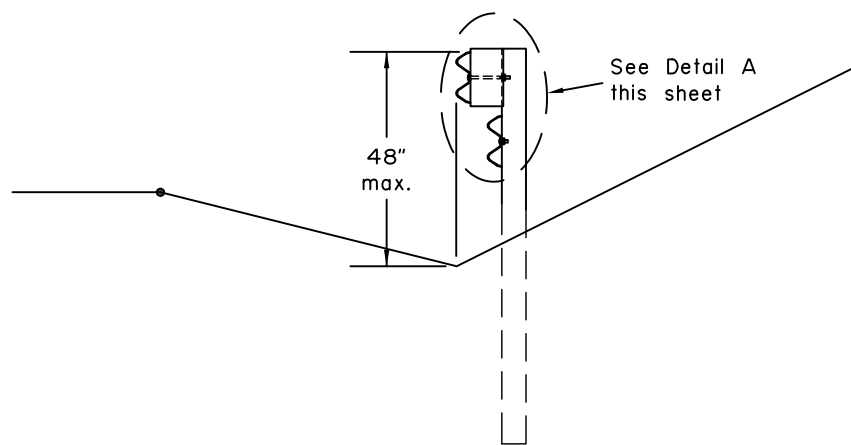

SECTION D-D
Section at Post F.
Face of Guardrail aligned
with center of ditch.

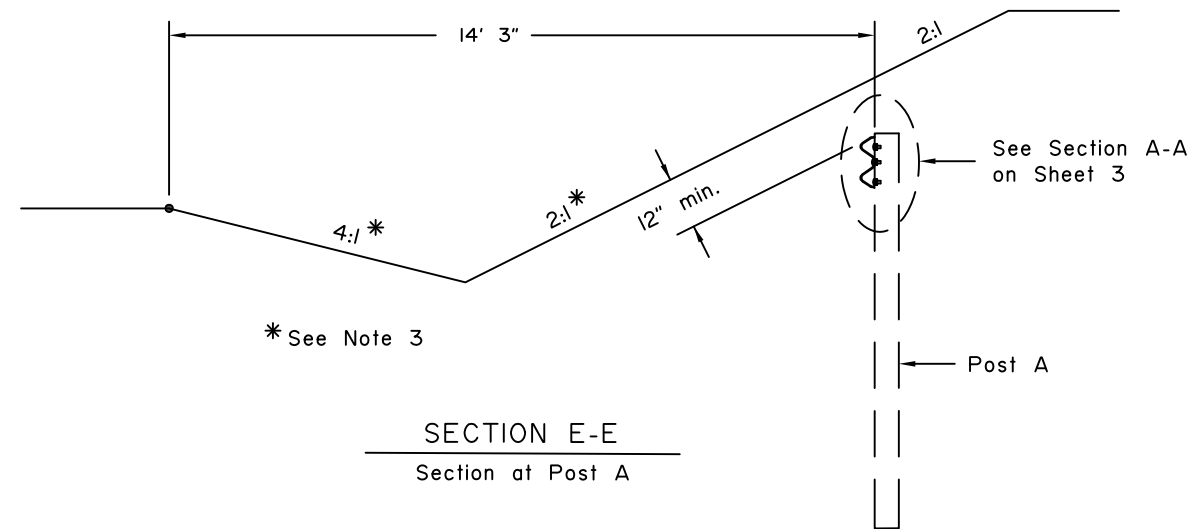

* See Note 3

SECTION E-E
Section at Post A

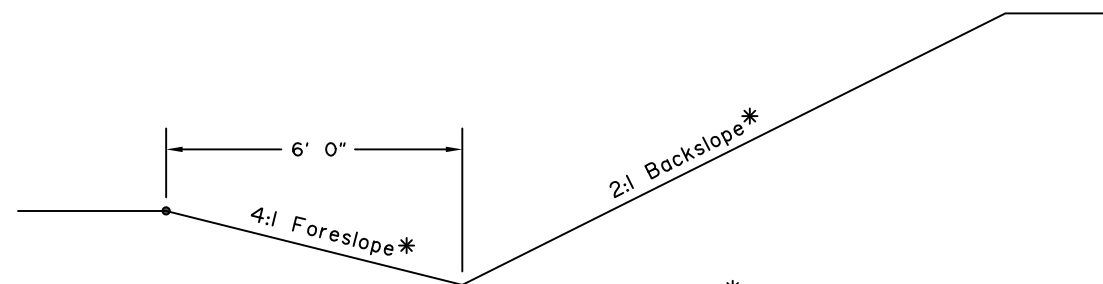

* See Note 3

SECTION F-F
Typical Ditch Section

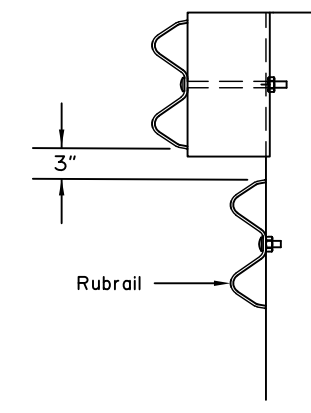

DETAIL A

State of Alaska DOT&PF
ALASKA STANDARD PLAN

**W31 GUARDRAIL
BURIED-IN-BACKSLOPE
TERMINAL**

Adopted as an Alaska
Standard Plan by: *Kenneth J. Fisher*
Kenneth J. Fisher, P.E.
Chief Engineer

Adoption Date: 02/08/2019

Last Code and Stds. Review
By: Date:

Next Code and Standards Review date: 02/08/2029

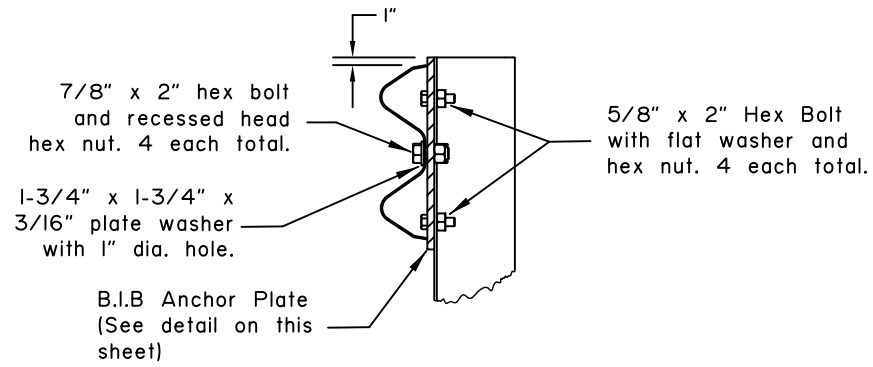

SECTION A-A
Typical for Posts A-C

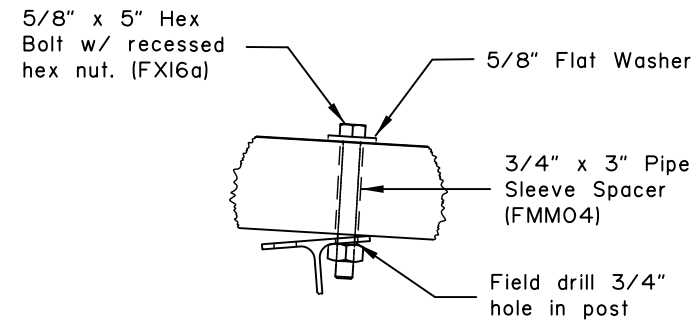

DETAIL C

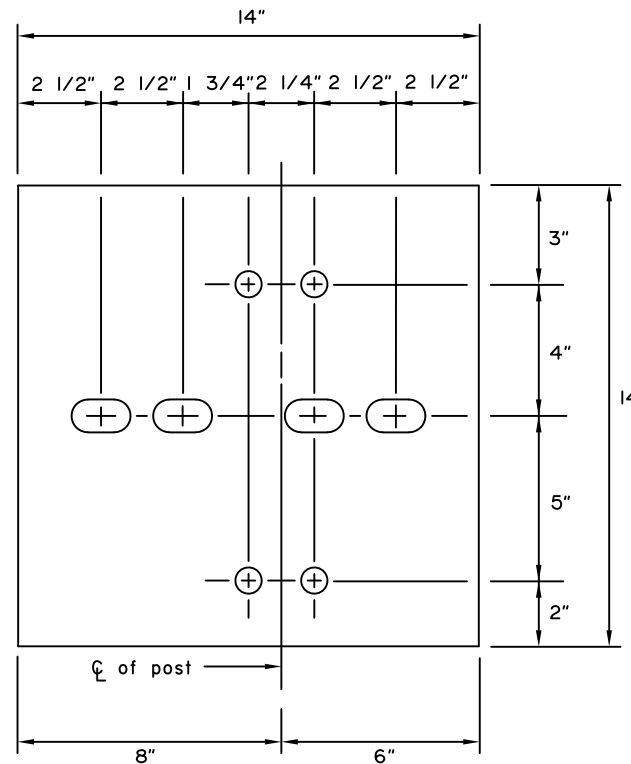

B.I.B. ANCHOR PLATE

- Plate Notes:
1. Plate is 1/2" galvanized ASTM A36 steel
 2. All circular holes are 3/4" diameter
 3. All slotted holes are 1" x 1-3/4"

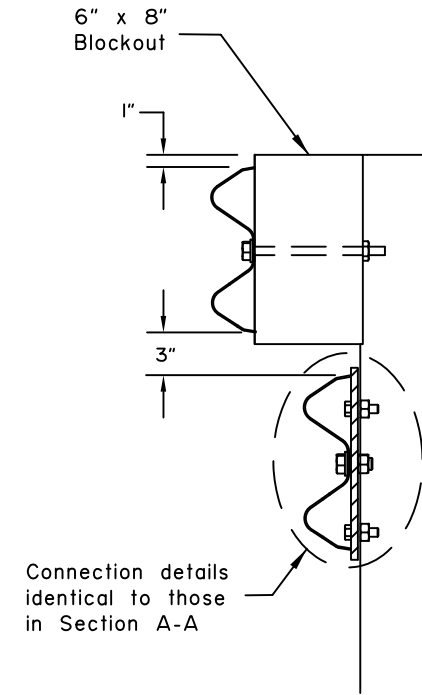

SECTION B-B
Post D only

GENERAL NOTES:

1. W-beam, blockout, and post details not shown here shall conform to Std Dwg G-05S.
2. All covered hardware shall comply with the Task Force 13 (TF13) Guide to Standardized Roadside Safety Hardware online publication.
3. Field drill 1" diameter holes in w-beam rail elements to make connections to the B.I.B. Anchor Plate.

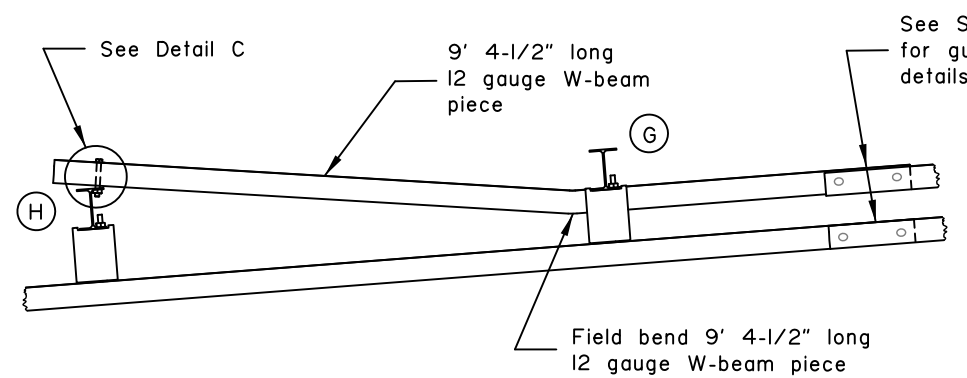

DETAIL A

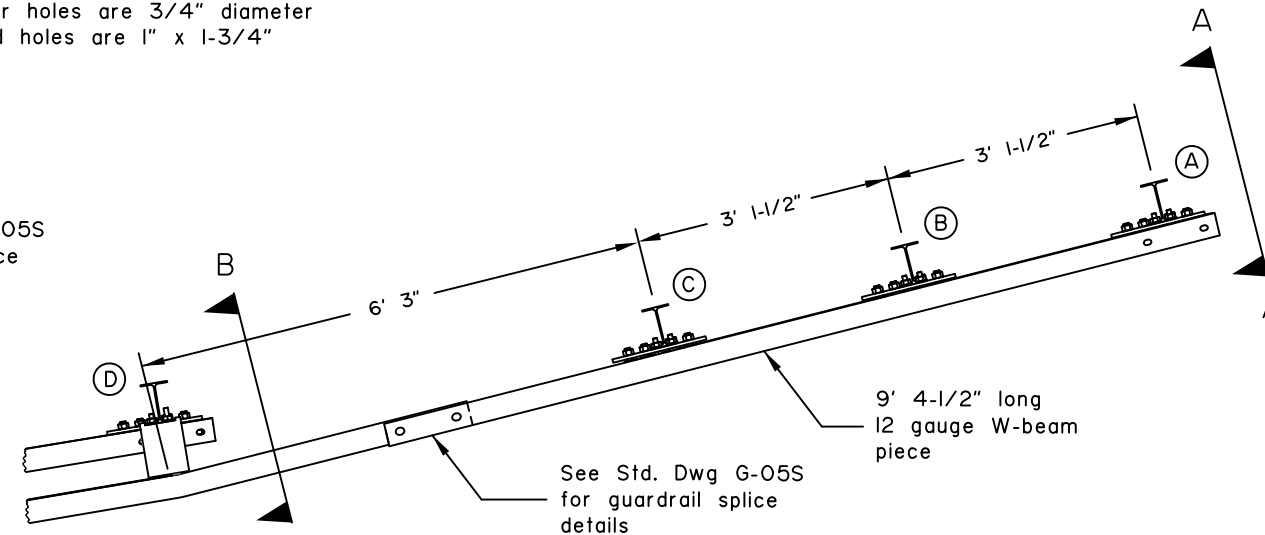

DETAIL B

State of Alaska DOT&PF
ALASKA STANDARD PLAN

**W31 GUARDRAIL
BURIED-IN-BACKSLOPE
TERMINAL**

Adopted as an Alaska
Standard Plan by: *Kenneth J. Fisher*
Kenneth J. Fisher, P.E.
Chief Engineer

Adoption Date: 02/08/2019

Last Code and Stds. Review
By: Date:

Next Code and Standards Review date: 02/08/2029

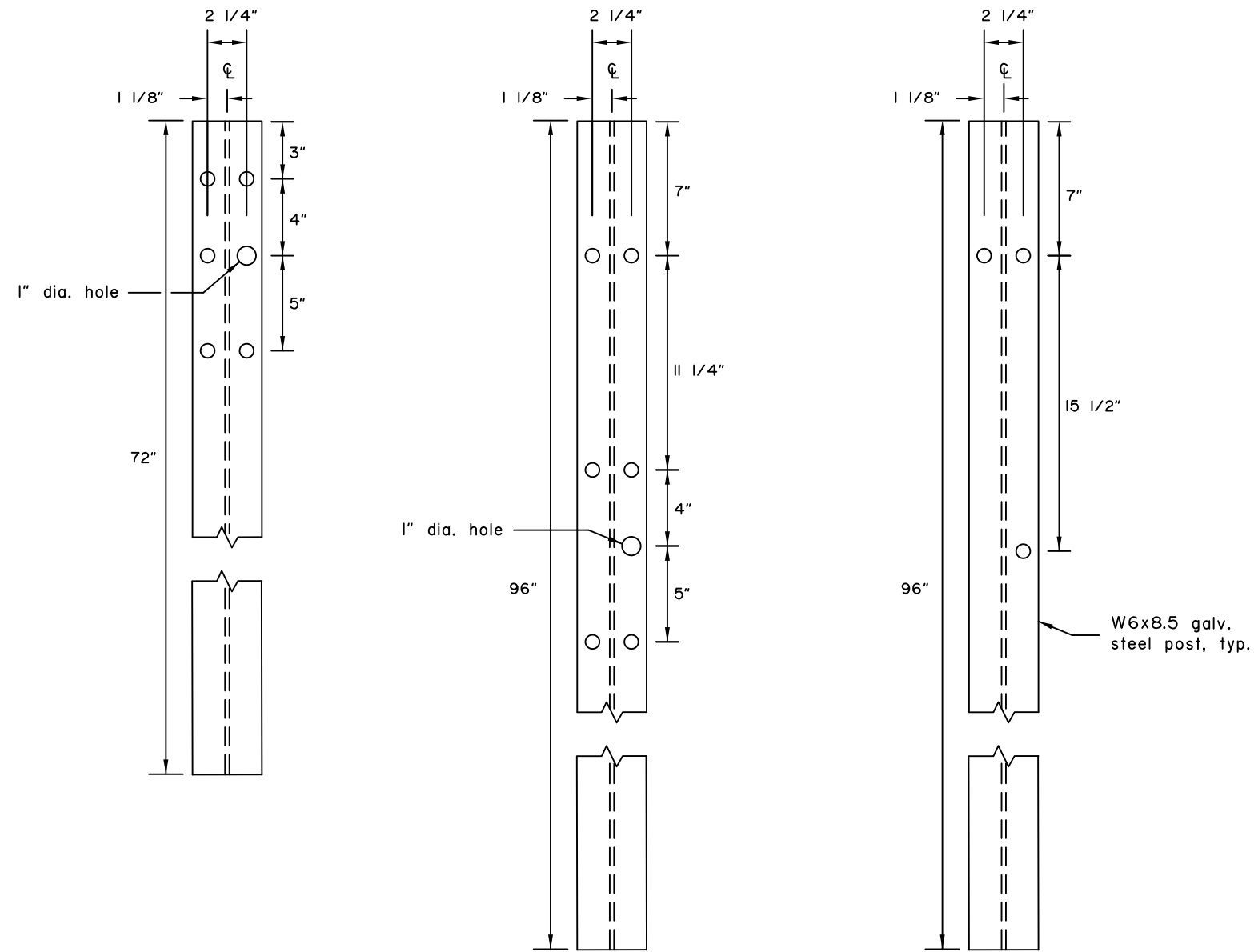

POSTS A-C

POST D

FIRST POST AFTER D
TO POST H

GENERAL NOTES:

1. W-beam, blockout, and post details not shown here shall conform to Std Dwg G-05S.
2. All covered hardware shall comply with the Task Force 13 (TF13) Guide to Standardized Roadside Safety Hardware online publication.
3. All post holes are 3/4" diameter, except those shown as 1" diameter.

State of Alaska DOT&PF
ALASKA STANDARD PLAN

**W31 GUARDRAIL
BURIED-IN-BACKSLOPE
TERMINAL**

Adopted as an Alaska
Standard Plan by: *Kenneth J. Fisher*
Kenneth J. Fisher, P.E.
Chief Engineer

Adoption Date: 02/08/2019

Last Code and Stds. Review
By: _____ Date: _____

Next Code and Standards Review date: 02/08/2029

G-16.00

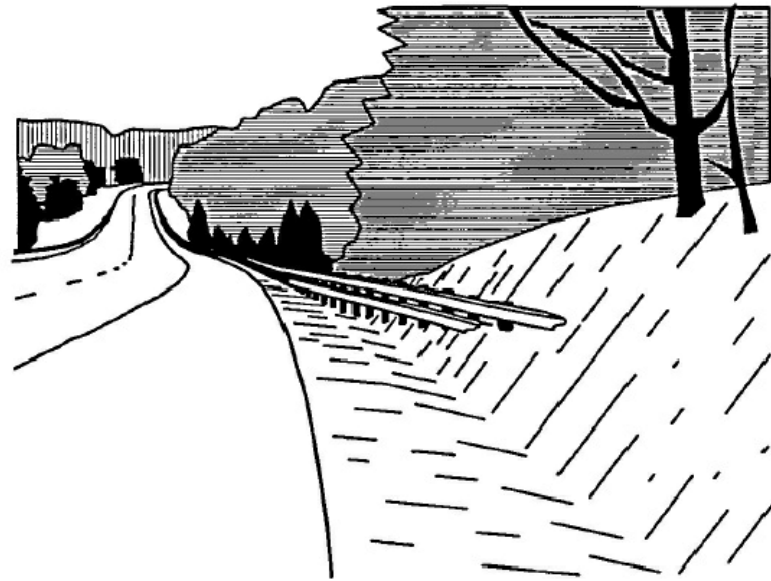

PERSPECTIVE VIEW

LATERAL OFFSET TABLE	
Post No.	Offset*
A	14' 3"
D	11' 2-1/4"
E	9' 1-1/2"
F	6' 0-1/4"
I	3'-1/4"

* Lateral offset is measured from the shoulder hinge point line to the back of guardrail. These offsets apply only for the foreslope and backslope conditions shown on the Sections on Sheet 2. For other foreslope or backslope conditions, these offsets need to be recomputed.

FLARE RATE TABLE	
Posts	Flare Rate
A - D	4 : 1
D - E	6 : 1
E - F	8 : 1
F - I	13 : 1
I - J	13:1 or flatter

CONSTRUCTION NOTES:

1. W-beam, blockout, and post details not shown here shall conform to Std Dwg G-05S.
2. All covered hardware shall comply with the Task Force 13 (TF13) Guide to Standardized Roadside Safety Hardware online publication.
3. This terminal is MASH TL-3 tested.
4. Pay limits for Buried-in-Backslope Terminal are from Post A to Post I. Payment for Buried-in-Backslope Terminal includes excavation and backfill work associated with burial from Post A to Post I.
5. Extend the W31 guardrail at a 13:1, or flatter, flare rate from Post I to Post J, where the typical guardrail run is parallel to the shoulder. Field bend w-beam rail element to transition from the 13:1 flare to parallel to the shoulder at Post J.
6. Provide a 20' x 75' object free area when backslopes are flatter than 2:1. When required, this work is subsidiary to the Buried-in-Backslope Terminal.

Provide 20' x 75' area free of fixed object hazards behind guardrail. Any signs or other highway appurtenances must be mounted on breakaway supports. See Construction Note 6.

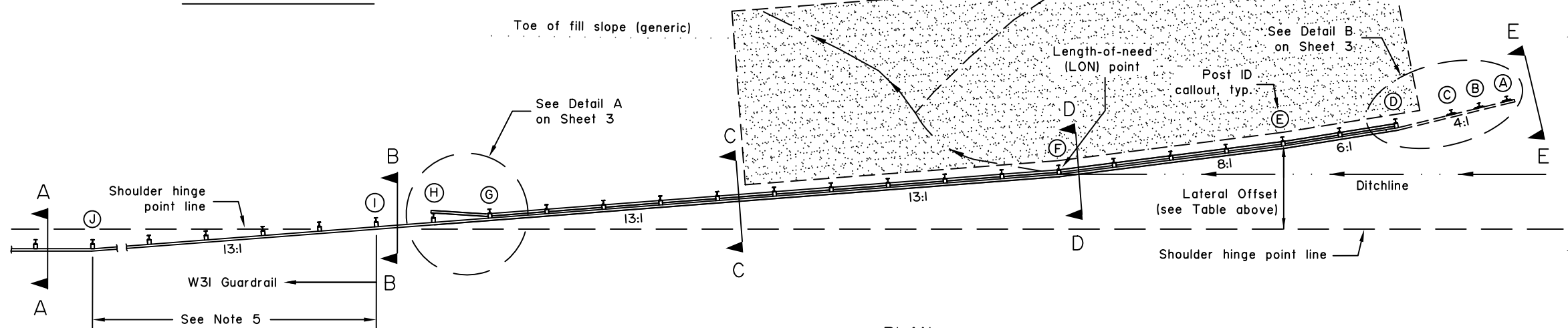

PLAN

All sections in this plan view are shown on Sheet 2

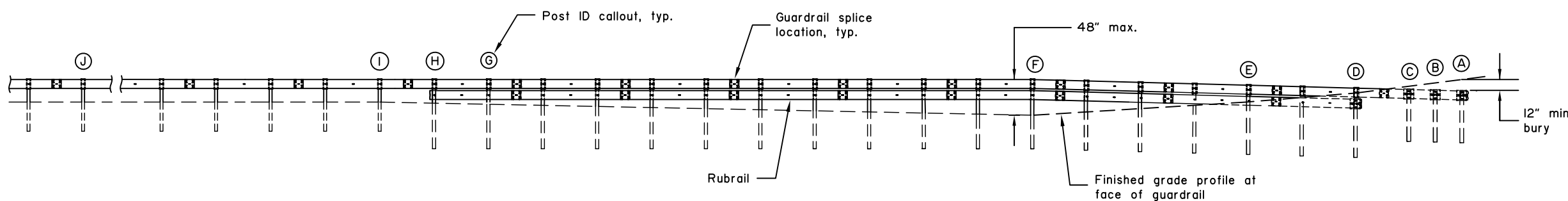

ELEVATION

DESIGN NOTES:

1. The LON point shown on this sheet is for the conditions shown in the Sections on Sheet 2. For other foreslope conditions, especially those with wider foreslopes and deeper ditches, the LON point will be at a different location. In this case, the LON point is where the top of the rail height first reaches 48" with respect to the finished grade at the face of the guardrail

State of Alaska DOT&PF
ALASKA STANDARD PLAN
W31 GUARDRAIL
BURIED-IN-BACKSLOPE
TERMINAL

Adopted as an Alaska Standard Plan by: *Kenneth J. Fisher*
Kenneth J. Fisher, P.E.
Chief Engineer

Adoption Date: 02/08/2019

Last Code and Stds. Review
By: Date:

Next Code and Standards Review date: 02/08/2029

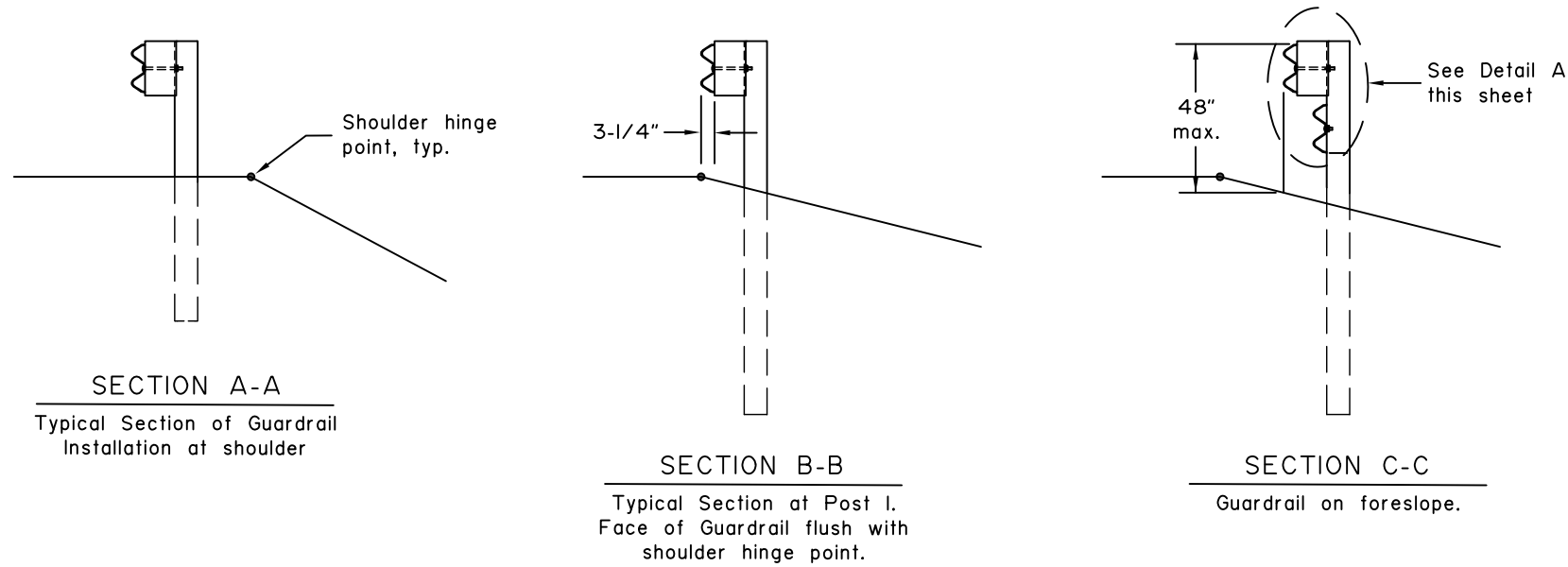

GENERAL NOTES:

1. W-beam, blackout, and post details not shown here shall conform to Std Dwg G-05S.
2. All covered hardware shall comply with the Task Force 13 (TF13) Guide to Standardized Roadside Safety Hardware online publication.
3. Foreslopes shall be 4:1 or flatter. Backslopes may be 1:1 maximum to 3:1 minimum. Lateral offsets shown on this sheet and Sheet 1 are based on the 4:1 foreslope, 2:1 backslope, and 18" ditch depth shown on this sheet. Other ditch depth, foreslope, or backslope conditions will require recomputation of lateral offsets and special grading of the top of guardrail to maintain the 48" maximum ground clearance to the top of guardrail and 12" minimum bury at Post A.

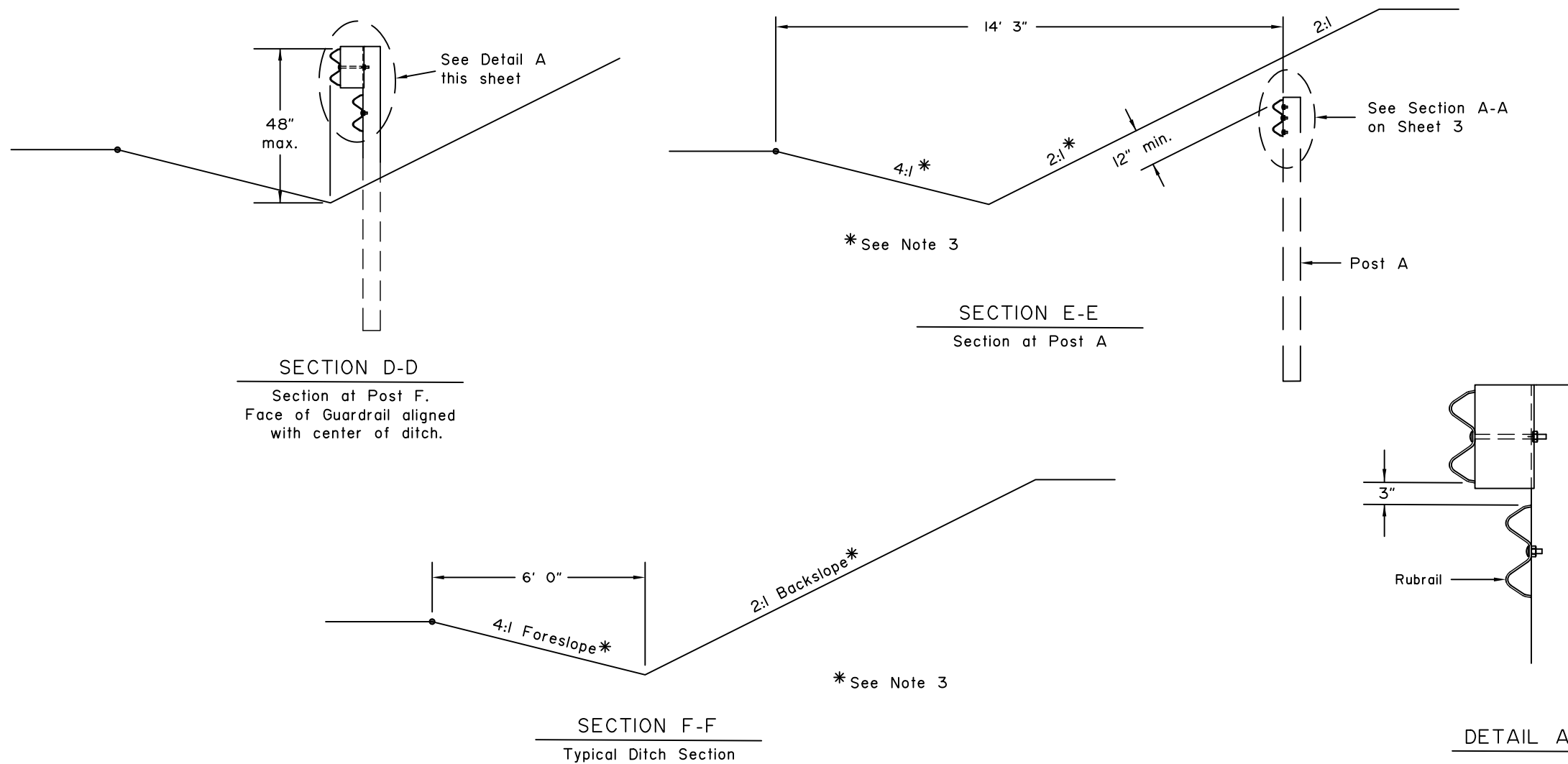

State of Alaska DOT&PF
ALASKA STANDARD PLAN

**W31 GUARDRAIL
BURIED-IN-BACKSLOPE
TERMINAL**

Adopted as an Alaska
Standard Plan by: *Kenneth J. Fisher*
Kenneth J. Fisher, P.E.
Chief Engineer

Adoption Date: 02/08/2019

Last Code and Stds. Review
By: Date:

Next Code and Standards Review date: 02/08/2029

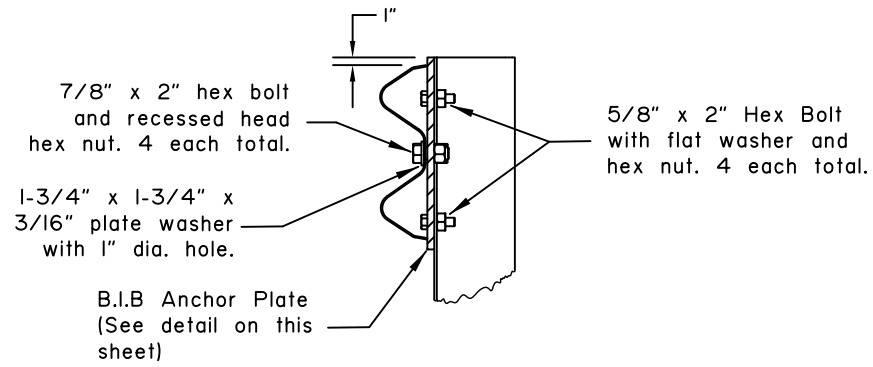

SECTION A-A
Typical for Posts A-C

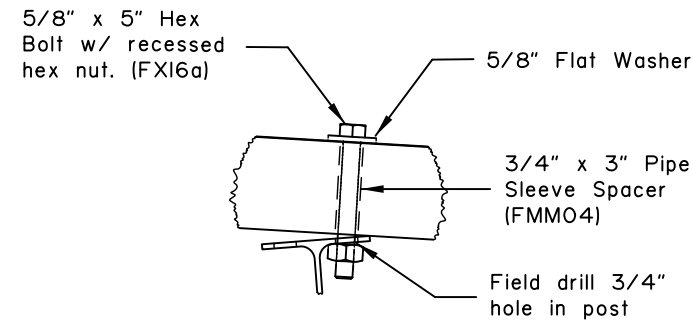

DETAIL C

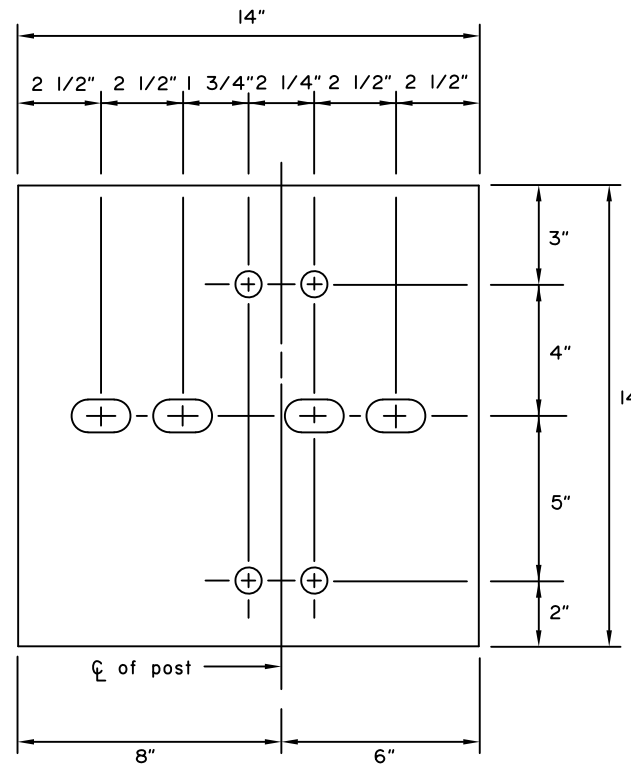

B.I.B. ANCHOR PLATE

- Plate Notes:
1. Plate is 1/2" galvanized ASTM A36 steel
 2. All circular holes are 3/4" diameter
 3. All slotted holes are 1" x 1-3/4"

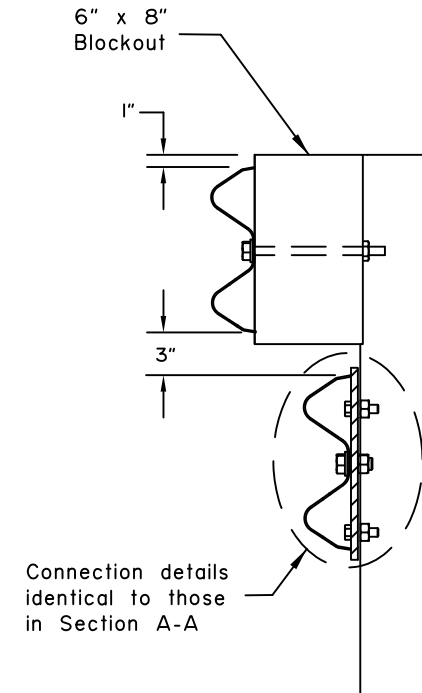

SECTION B-B
Post D only

GENERAL NOTES:

1. W-beam, blockout, and post details not shown here shall conform to Std Dwg G-05S.
2. All covered hardware shall comply with the Task Force 13 (TF13) Guide to Standardized Roadside Safety Hardware online publication.
3. Field drill 1" diameter holes in w-beam rail elements to make connections to the B.I.B. Anchor Plate.

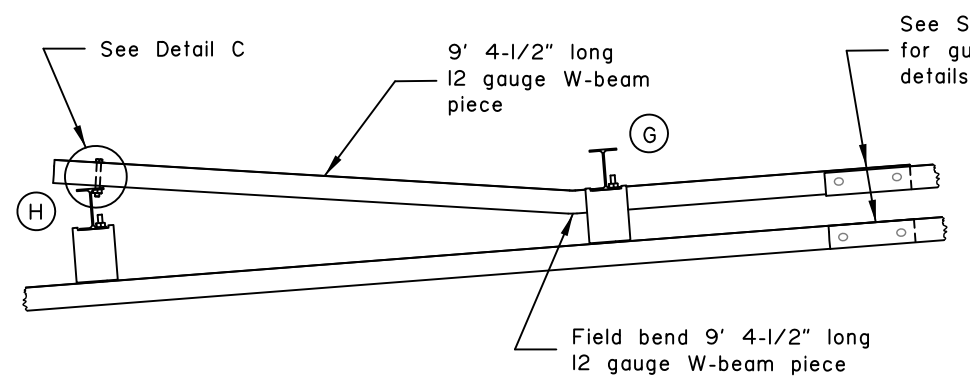

DETAIL A

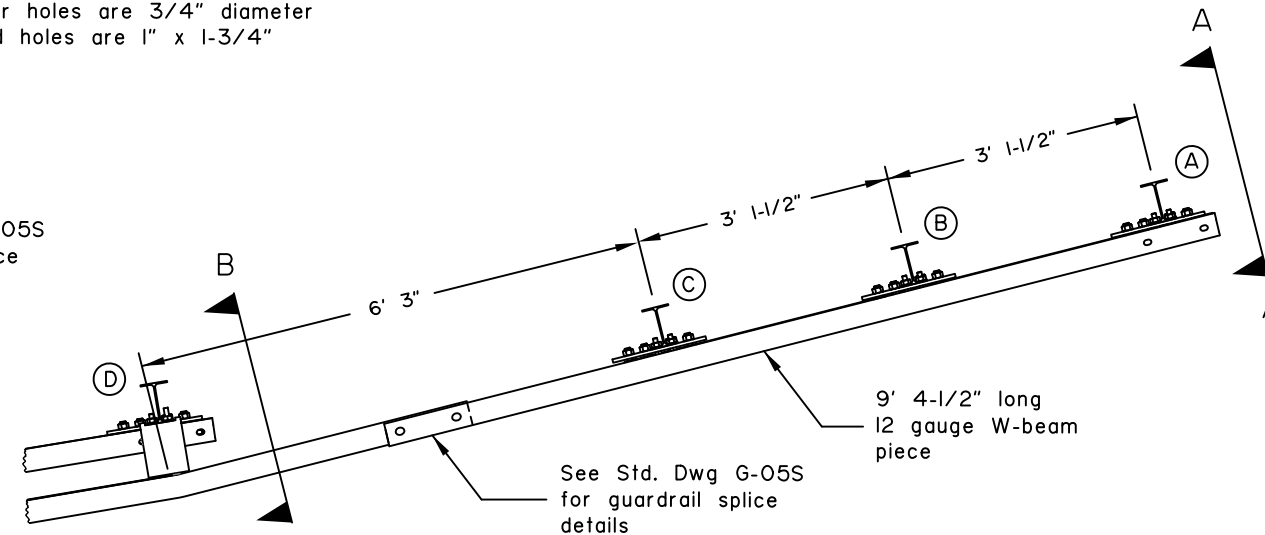

DETAIL B

State of Alaska DOT&PF
ALASKA STANDARD PLAN

**W31 GUARDRAIL
BURIED-IN-BACKSLOPE
TERMINAL**

Adopted as an Alaska
Standard Plan by: *Kenneth J. Fisher*
Kenneth J. Fisher, P.E.
Chief Engineer

Adoption Date: 02/08/2019

Last Code and Stds. Review
By: Date:

Next Code and Standards Review date: 02/08/2029

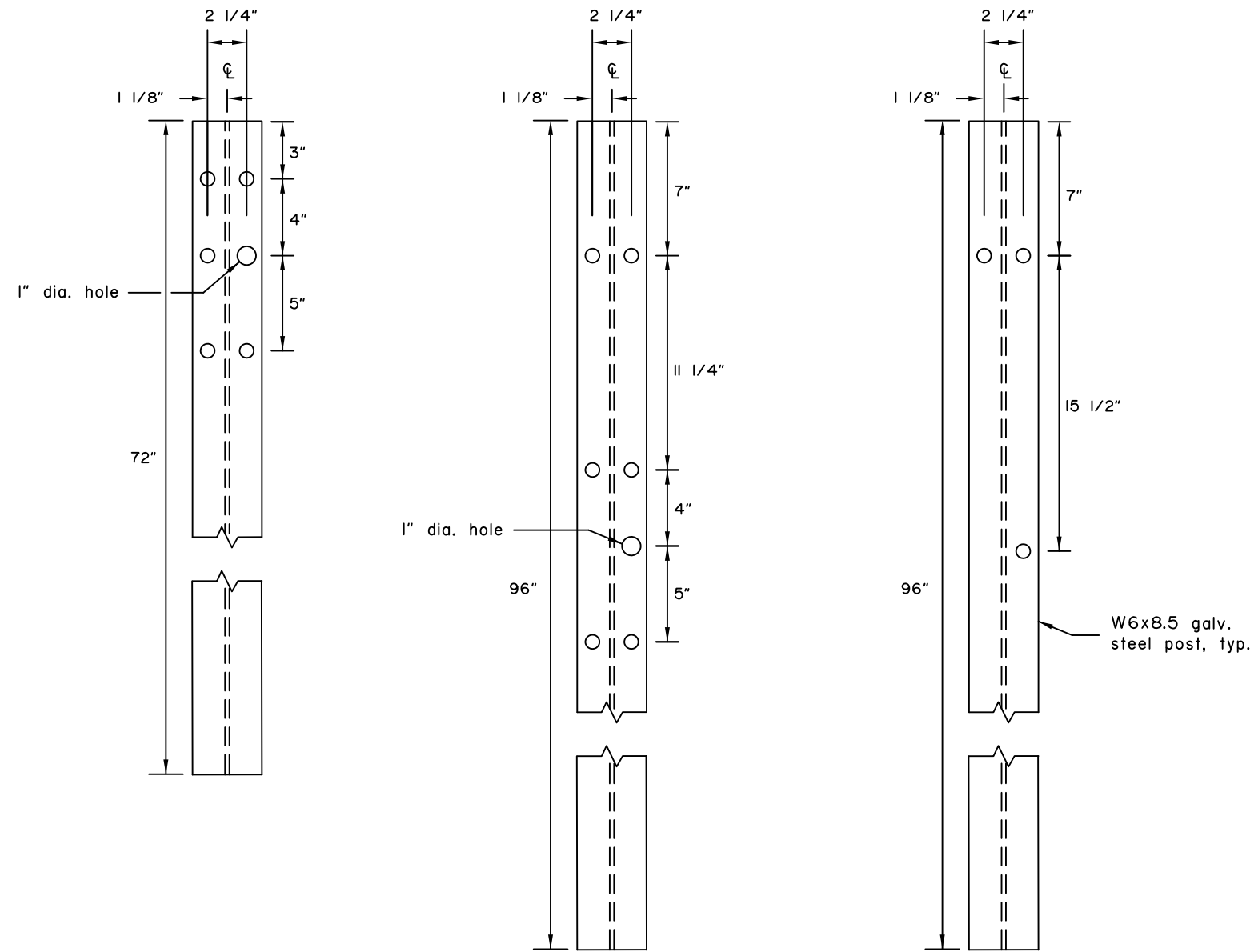

POSTS A-C

POST D

FIRST POST AFTER D
TO POST H

GENERAL NOTES:

1. W-beam, blockout, and post details not shown here shall conform to Std Dwg G-05S.
2. All covered hardware shall comply with the Task Force 13 (TF13) Guide to Standardized Roadside Safety Hardware online publication.
3. All post holes are 3/4" diameter, except those shown as 1" diameter.

State of Alaska DOT&PF
ALASKA STANDARD PLAN

**W31 GUARDRAIL
BURIED-IN-BACKSLOPE
TERMINAL**

Adopted as an Alaska
Standard Plan by: *Kenneth J. Fisher*
Kenneth J. Fisher, P.E.
Chief Engineer

Adoption Date: 02/08/2019

Last Code and Stds. Review
By: _____ Date: _____

Next Code and Standards Review date: 02/08/2029

G-16.00

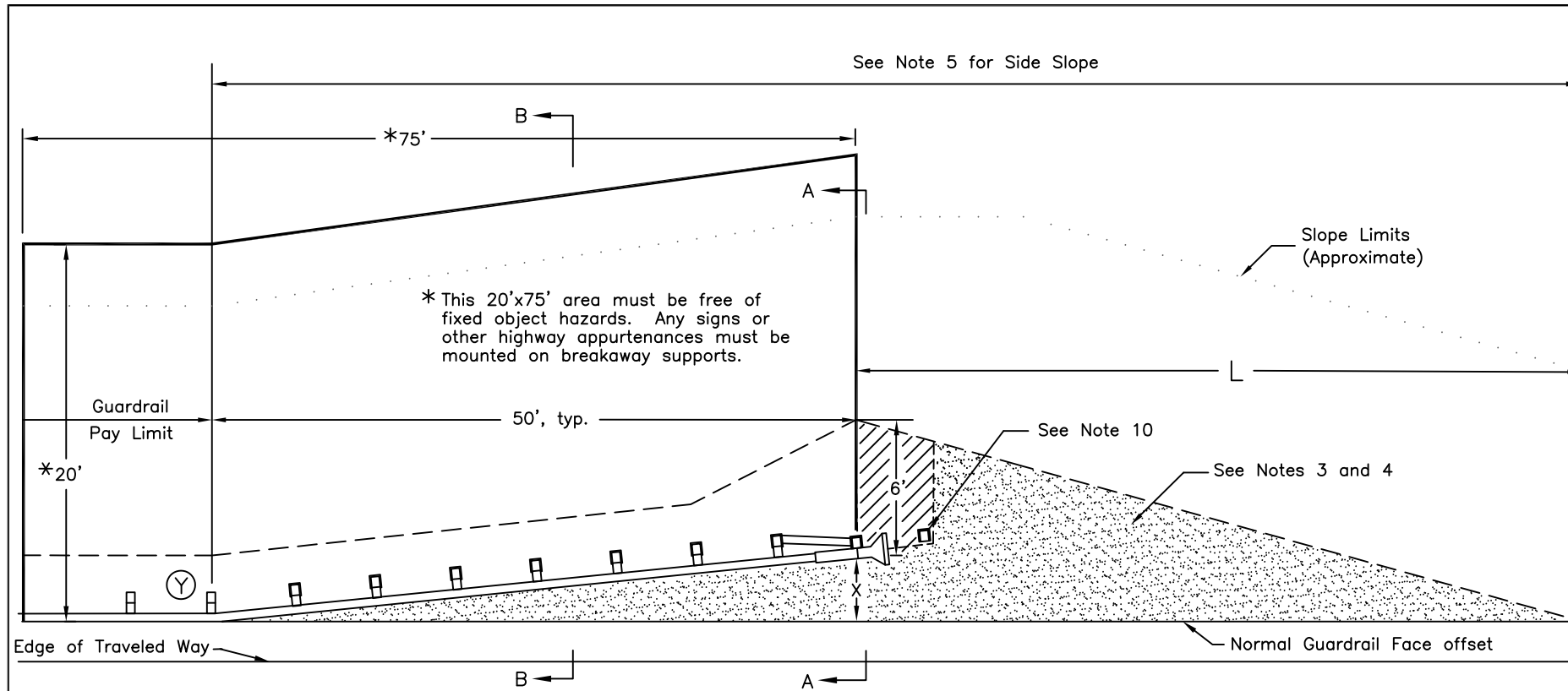

STANDARD GUARDRAIL TERMINAL WIDENING DETAIL

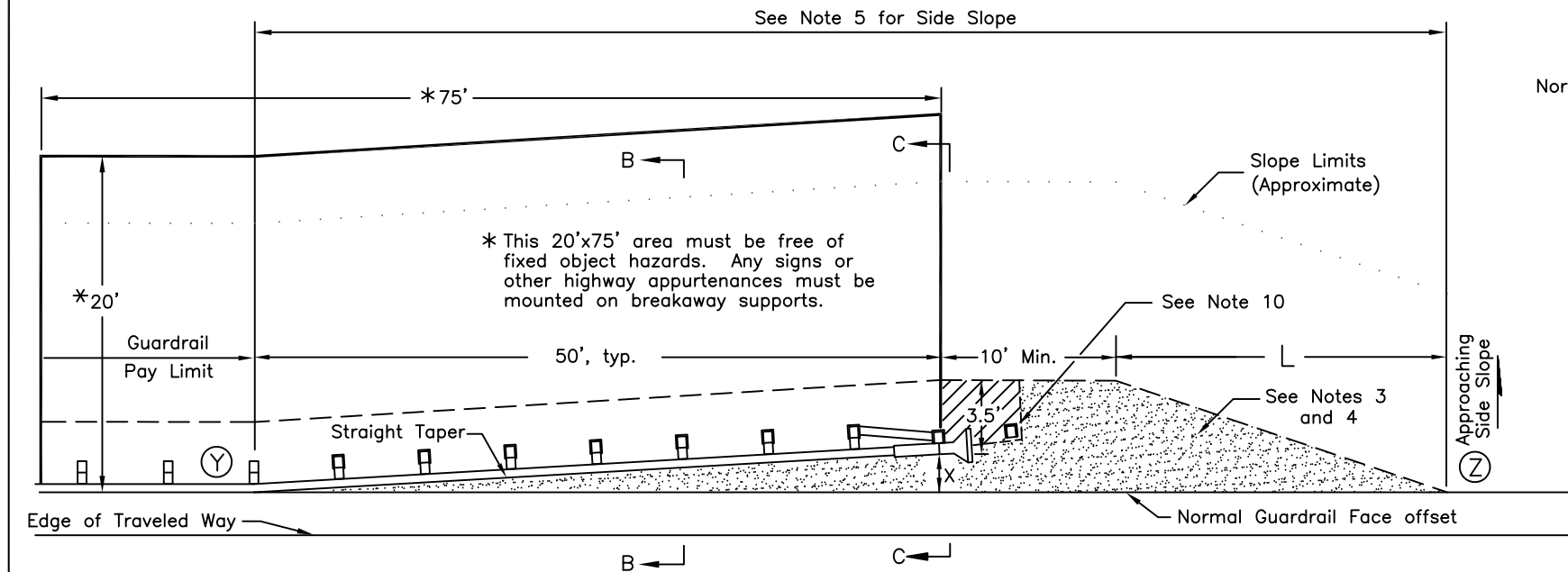

ALTERNATE GUARDRAIL TERMINAL WIDENING DETAIL

(USE ONLY WHEN LIMITED RIGHT-OF-WAY OR LIMITING SITE CONDITIONS MAKE THE STANDARD DETAIL INFEASIBLE)

X=End offset. See manufacturer's information for the range of acceptable end offsets for each MASH compliant terminal.

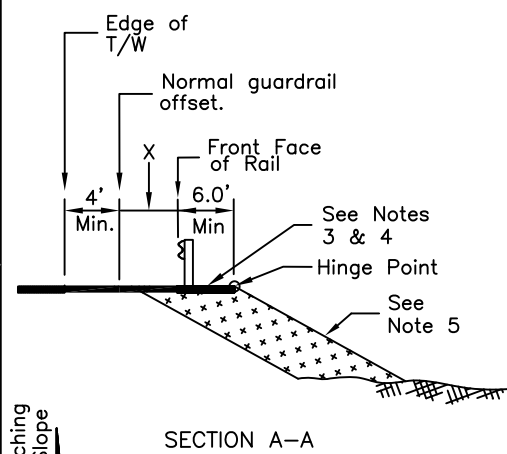

SECTION A-A

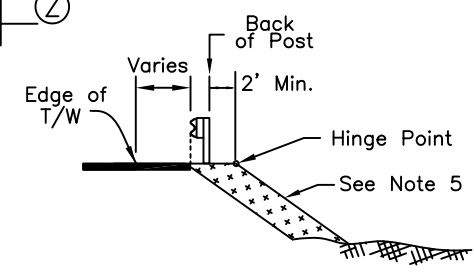

SECTION B-B
(Applies to both details)

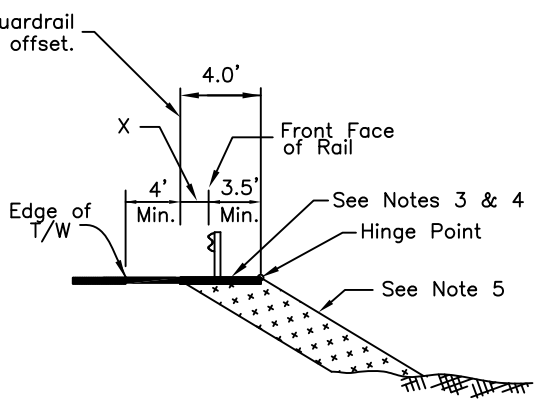

SECTION C-C

GENERAL NOTES

1. This Std. Dwg. applies to all MASH approved guardrail end terminals (GETs). The alternate detail may only be used with parallel or tangent GETs. The terminal details shown are for illustration only – see manufacturer's drawings for actual post, rail, strut, etc. configuration and layout.
2. Use this Std. Widening Detail for all GETs except when limited right-of-way or limiting site conditions make the use of the Std. Widening Detail infeasible. In that case, the alternate detail is permissible.
3. Construct the shaded areas to match the slope of the adjacent shoulder. The slope may be increased to 10:1 if identified in the plans or when approved by the engineer. Match the slope when the shoulder slopes toward the road as well as away from the road.
4. On paved roads, the shaded areas shall be paved. On gravel roads, surface the shaded areas with the same materials used to surface the travel lanes.
5. From point (Y) to point (Z) make the side slope match the approaching side slope except where it is flatter than 4:1. In that case, the slope may be steepened to 4:1.
6. Attach a flexible marker at the beginning of each GET.
7. The max. allowable height for foundation tubes or other steel components of terminal post breakaway systems is 4" above the surrounding grade.
8. The details on this sheet do not apply to W31 Downstream End Anchors (Std Dwg G-14).
9. The details on this sheet apply to GETs on both the approach and downstream ends on two-way undivided roads and to any downstream MASH compliant GETs.
10. Some MASH GET systems have an additional post/anchor at the approximate location shown. If this post/anchor is present do not pave the diagonally hatched area. If not present, pave the diagonally hatched area also.

Taper Lengths (L) for Common End Offsets (X)		
End Offset	Standard Detail	Alternate Detail
0'	24.0'	13.0'
1'	26.0'	17.0'
1.5'	28.0'	19.0'
2'	30.0'	21.0'
2.5'	32.0'	22.0'
4'	37.0'	28.0'

Interpolate if the end offset falls between table values

State of Alaska DOT&PF
ALASKA STANDARD PLAN

**WIDENING FOR
GUARDRAIL END TERMINALS**

Adopted as an Alaska Standard Plan by: *Kenneth J. Fisher*
Kenneth J. Fisher, P.E.
Chief Engineer

Adoption Date: 02/08/2019

Last Code and Stds. Review By: _____ Date: _____

Next Code and Standards Review date: 02/08/2029

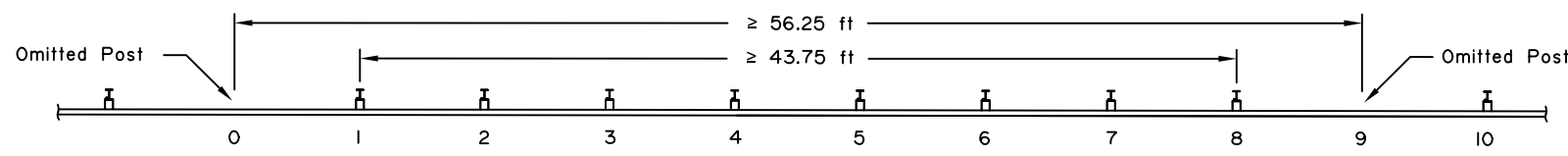

(A) TANGENT RUN OF W31 GUARDRAIL
Min. distance between omitted posts

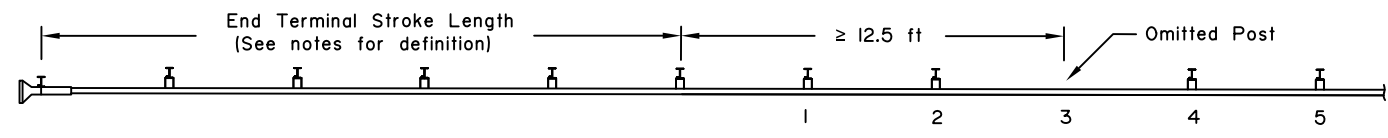

(B) IN VICINITY OF CRASHWORTHY END TERMINAL

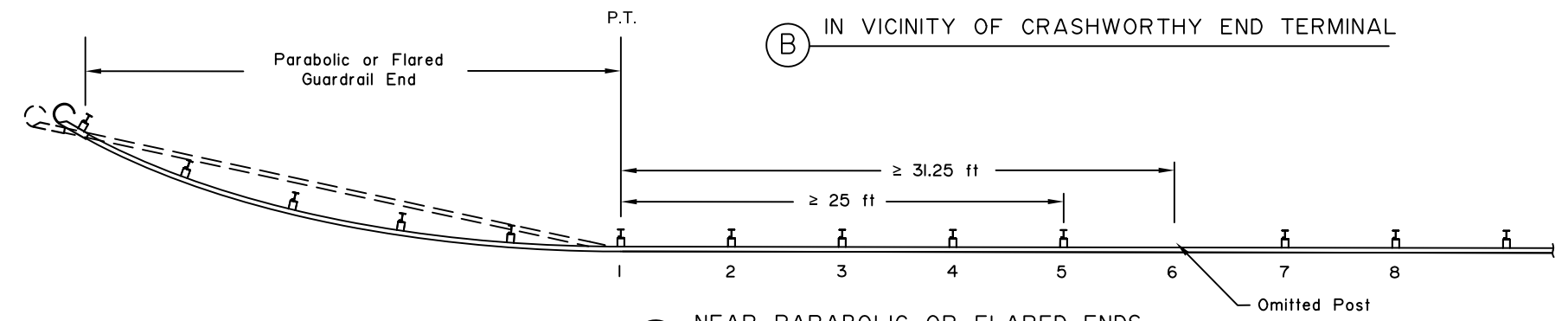

(C) NEAR PARABOLIC OR FLARED ENDS

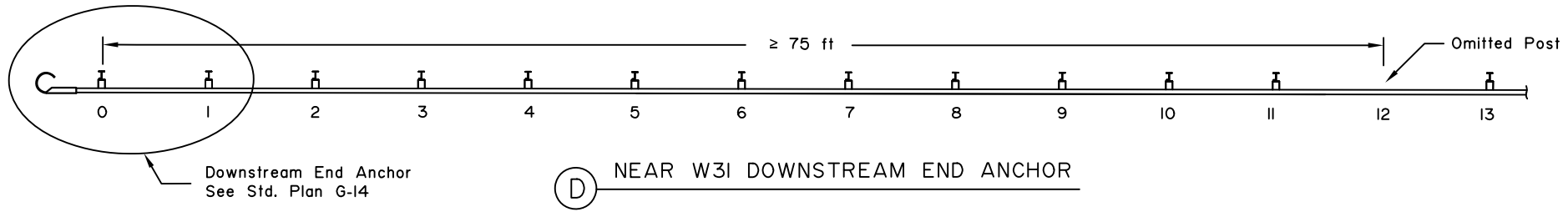

(D) NEAR W31 DOWNSTREAM END ANCHOR

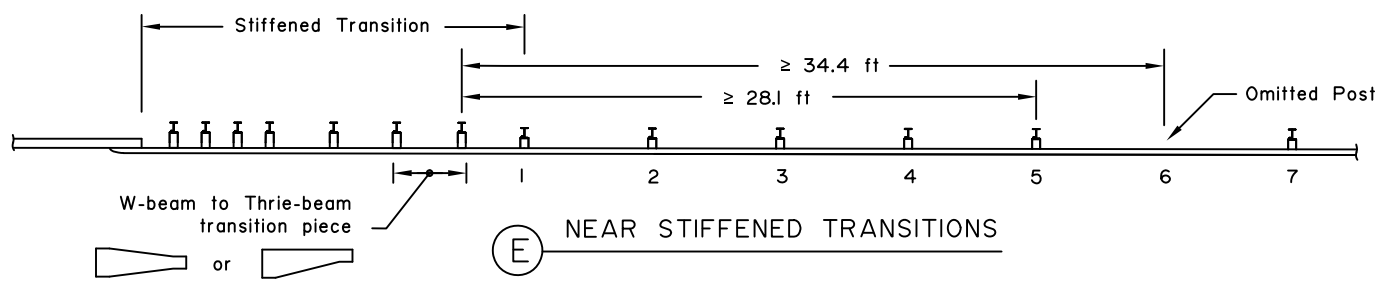

(E) NEAR STIFFENED TRANSITIONS

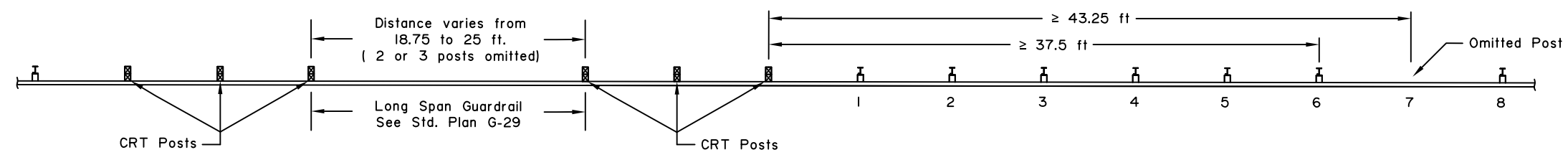

(F) NEAR LONG SPAN SECTIONS

CONSTRUCTION NOTES

1. Omit guardrail posts only when necessary and with approval of the Engineer. A necessary condition is the presence of a shallow underground obstruction, such as a culvert or utility line (sewer, fiber optic, gas, power, etc.). Bedrock and boulders are not a condition warranting an omission of a post. See Standard Specifications for Highway Construction, Section 606-3.02 for installation of posts in bedrock, broken rock, or boulders.
2. Guardrail depicted in this drawing is W31 with a standard post spacing of 6' - 3".
3. Near terminals:
 - a. On parallel (energy absorbing) end terminals, the omitted post must not be closer than 12.5 ft. to the end of the full stroke of the terminal (see Detail B). The stroke length is defined as the the maximum distance the terminal head travels when impacted. This varies by manufacturer. See specific manufacturer information for this distance.
 - b. On flared or parabolic terminals, the omitted post must not be closer than 25 ft. of the PT post or not closer than the 6th post from the beginning of the flare or parabola (see detail C).
4. Adjacent to 2:1 slopes - do not omit guardrail posts at the breakpoint or on the 2:1 slope.
5. On 8:1 approach slopes - do not omit posts from guardrail installed behind the slope break.
6. Do not omit posts from guardrail runs with a curb in front of the guardrail.

State of Alaska DOT&PF
ALASKA STANDARD PLAN

**W31 GUARDRAIL
SINGLE POST LEAVE-OUT**

Adopted as an Alaska Standard Plan by: *Carolyn H. Morehouse*

Carolyn Morehouse, P.E.
Chief Engineer

Adoption Date: 09/15/2022

Last Code and Stds. Review
By: LRG Date: 09/15/2022

Next Code and Standards Review date: 09/15/2032

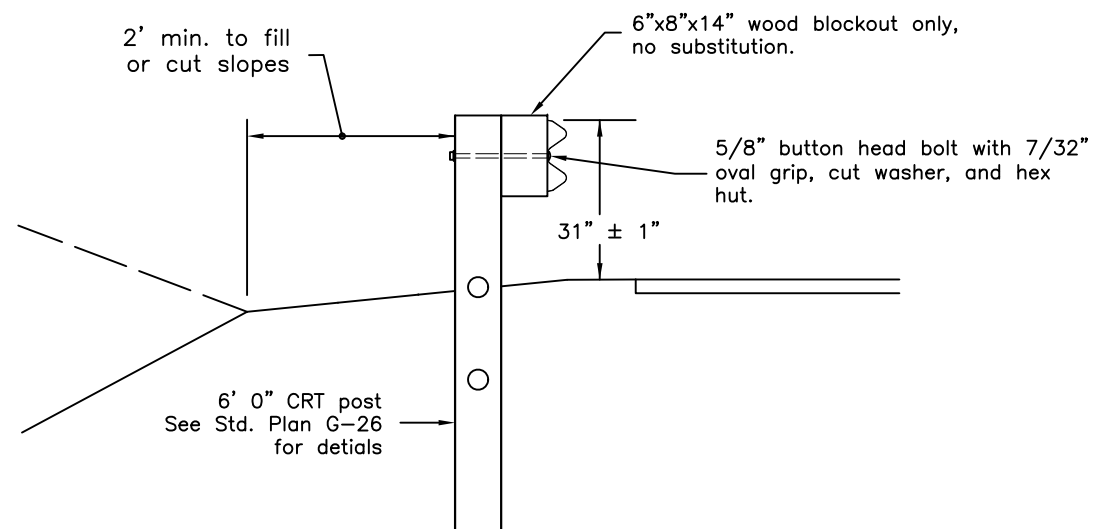

SECTION A-A

Typical for all CRT post locations shown in the plan view

CONSTRUCTION NOTES

1. See Standard Drawings G-00 and G-05 for additional guardrail and guardrail hardware details. See G-26 Sheet 1 of 3 for CRT post details.
2. Provide 1-foot minimum lateral clearance between posts and underground obstruction.
3. Nesting of rail elements in the long span area is not allowed.
4. For omission of a single post, see Standard Plan G-27.

DESIGN NOTES

1. Total installed length of guardrail and end anchorage (including end terminals, downstream anchors, etc.) shall not be less than 62.5 feet measured from the outermost CRT post on both the upstream and downstream ends.
2. No fixed objects are allowed within 8'-0" from the back of posts in the area indicated on this plan. This is the crash-tested lateral dynamic deflection of the long span system.
3. Do not use this long span plan when there is curb installed in front of the guardrail, including the area of CRT posts.

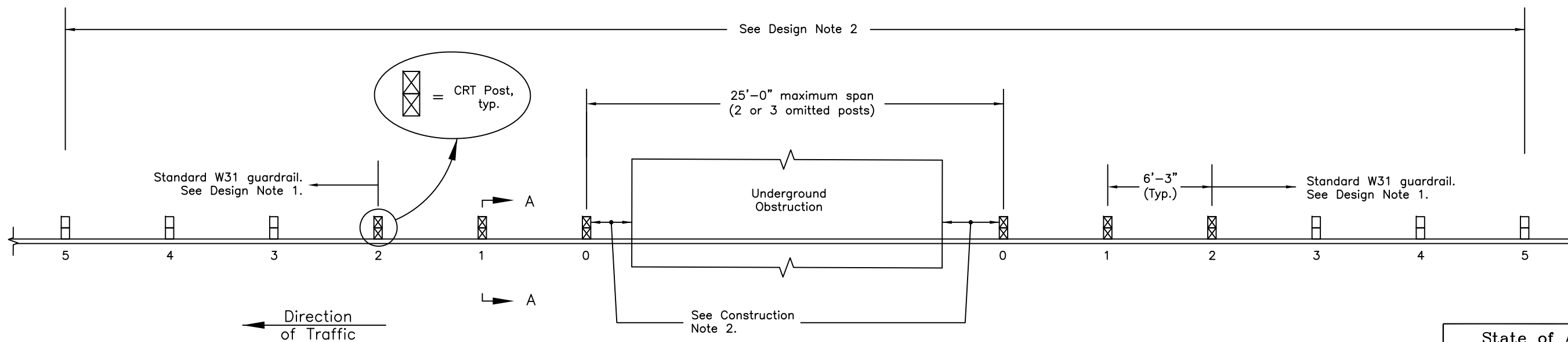

LONG SPAN GUARDRAIL PLAN

State of Alaska DOT&PF
ALASKA STANDARD PLAN

**LONG SPAN
W31 GUARDRAIL**

Adopted as an Alaska Standard Plan by: *Carolyn H Morehouse*
Carolyn Morehouse, P.E.
Chief Engineer

Adoption Date: 09/15/2022

Last Code and Stds. Review
By: LRG Date: 09/15/2022

Next Code and Standards Review date: 09/15/2032

G-29.01

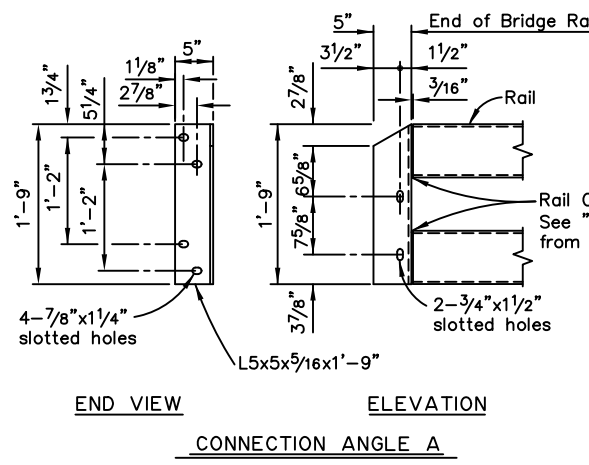
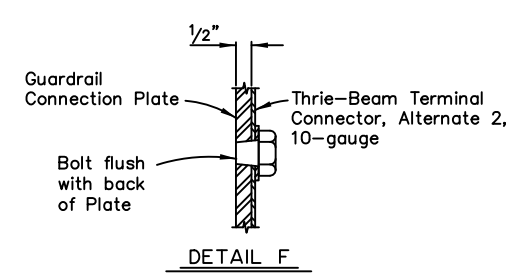
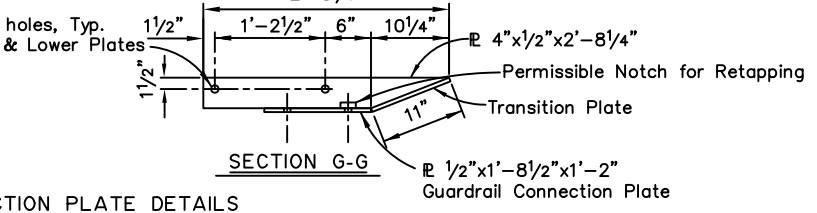
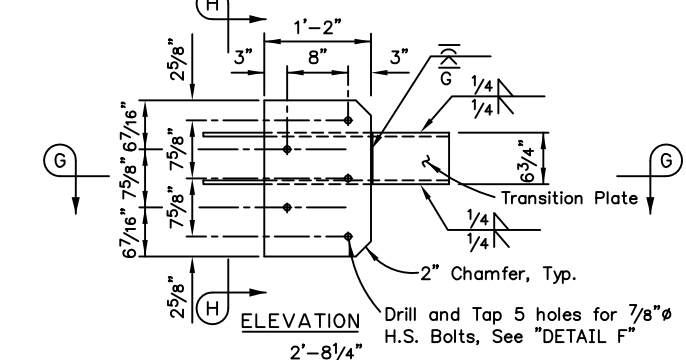
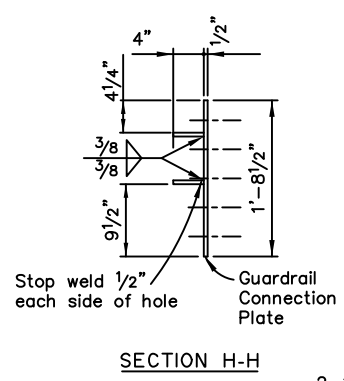
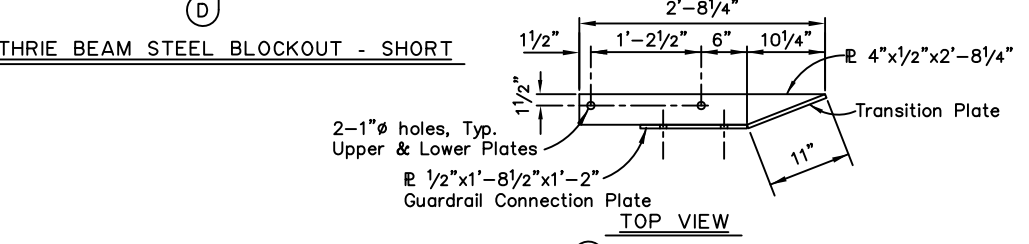
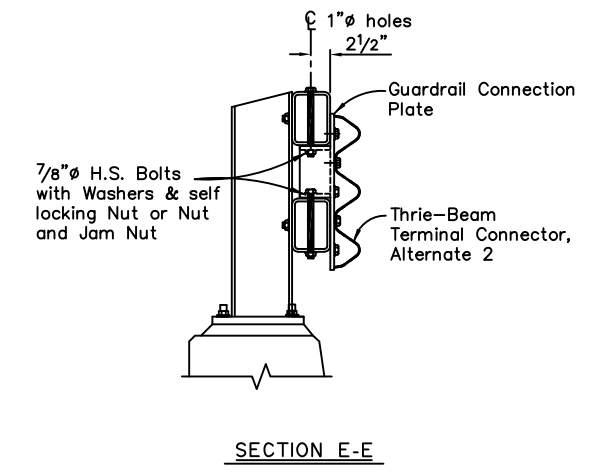
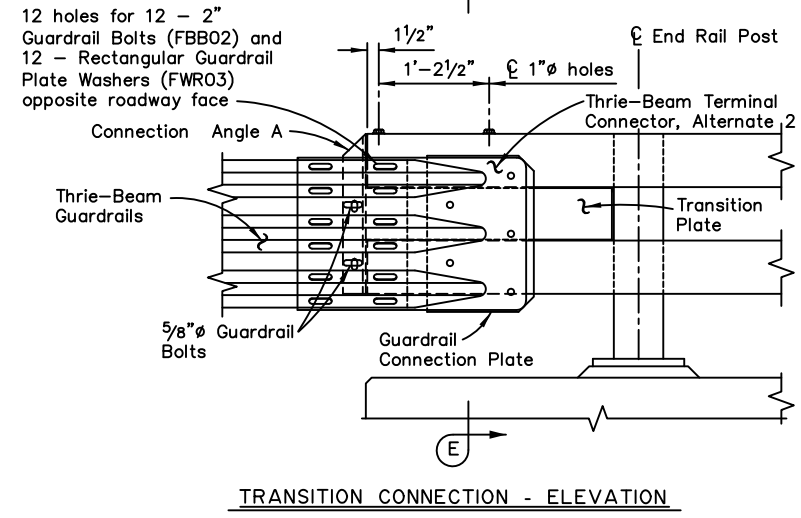
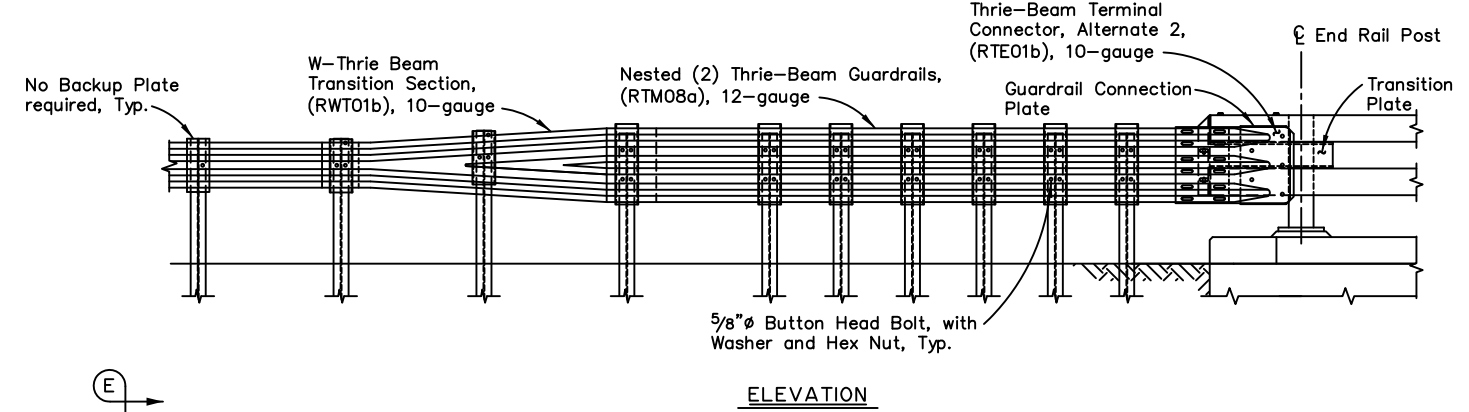
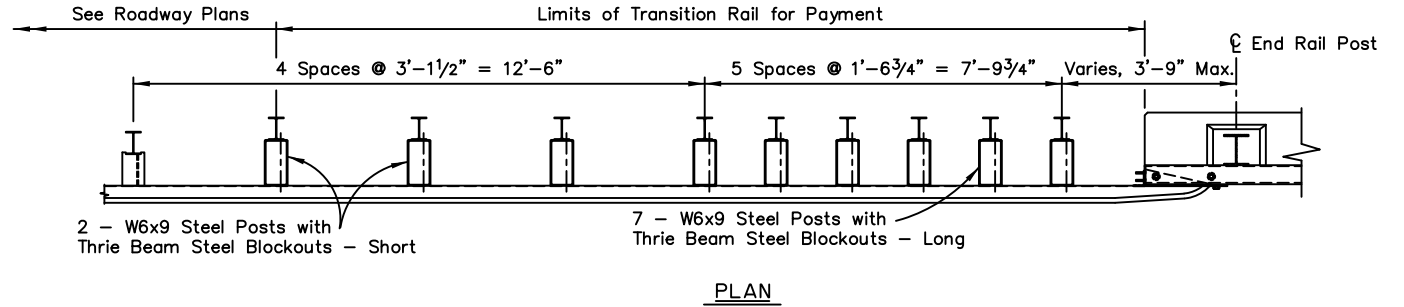
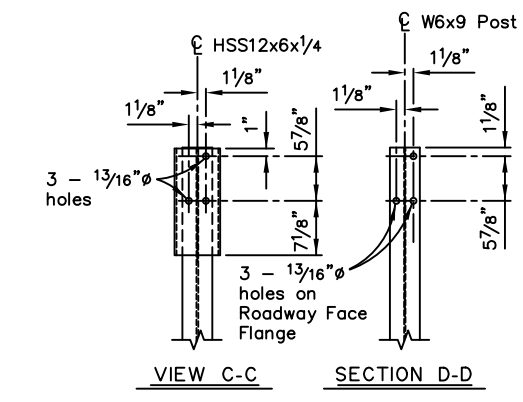
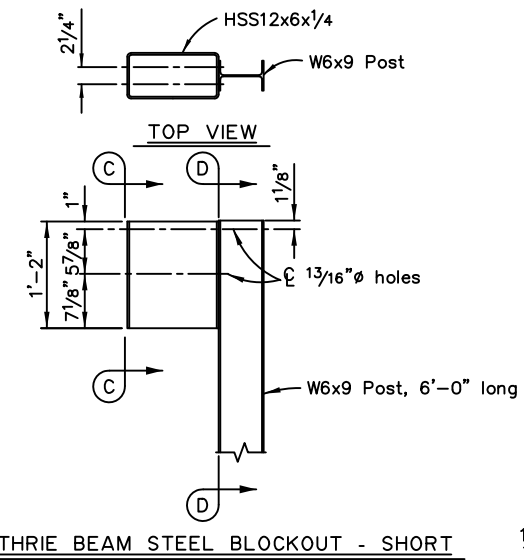
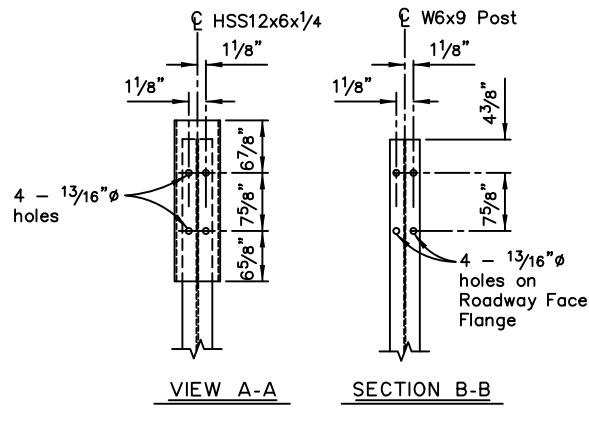
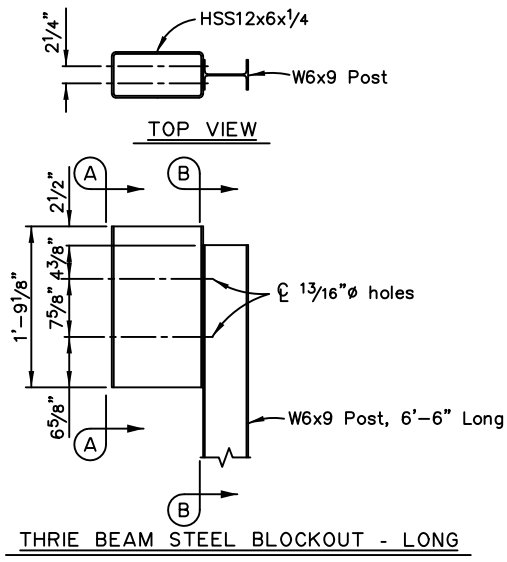

- NOTES:**
1. Conform to G-00, G-05, and G-10 of the Standard Plans for all Thrie Beam Transition details not shown.
 2. Thrie Beam Transition part numbers are listed in parentheses () and referenced in the "Task Force 13 Guide to Standardize Roadside Hardware."

GUARDRAIL CONNECTION PLATE DETAILS

No Scale

State of Alaska DOT&PF
ALASKA STANDARD PLAN

**MASH BRIDGE RAIL
THRIE BEAM TRANSITION**

Adopted as an Alaska Standard Plan by: *Carolyn H Morehouse*
Carolyn Morehouse, P.E.
Chief Engineer

Adoption Date: 09/15/2022

Last Code and Stds. Review
By: SEM Date: 07/17/2020

Next Code and Standards Review Date: 07/17/2030

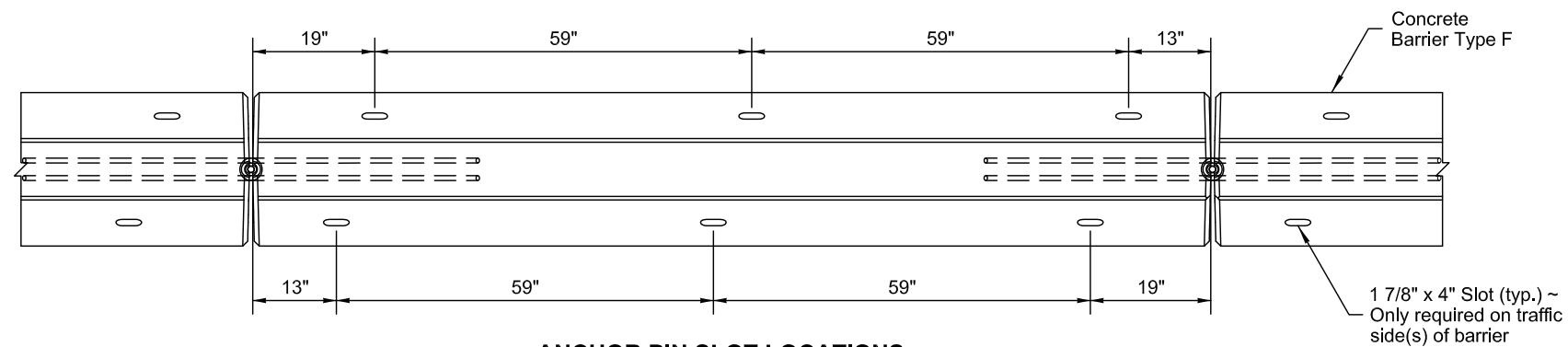

ANCHOR PIN SLOT LOCATIONS

Reinforcing steel not shown for clarity

CONSTRUCTION NOTES

1. When this barrier is used as a temporary traffic control device, provide retroreflective tabs or stripes meeting the requirements of Section 643 of the Standard Specifications.
2. When this barrier is used in a permanent application, provide reflector assemblies meeting the requirements of Section 614 of the Standard Specifications.

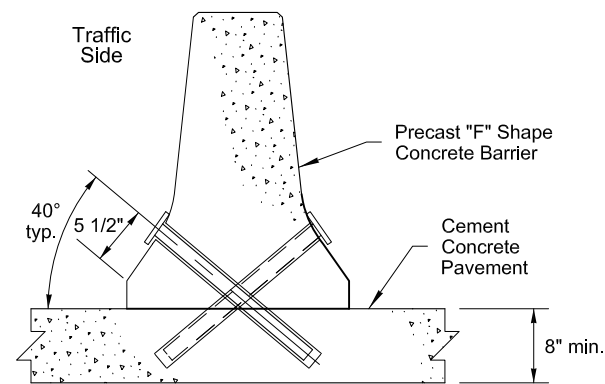

CONCRETE ANCHOR PIN DETAILS

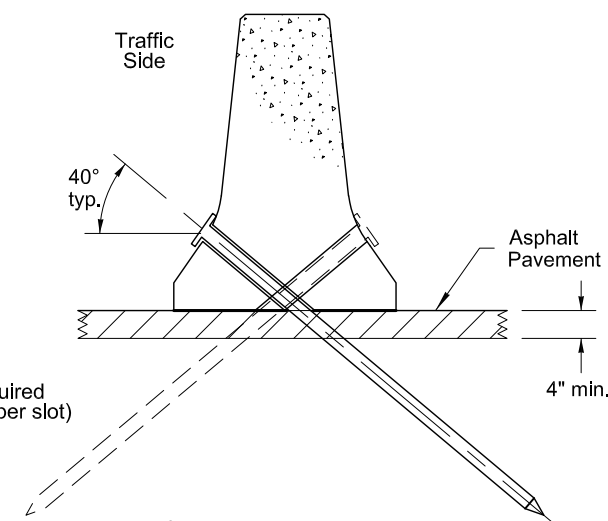

ASPHALT PAVEMENT ANCHOR PIN LOCATIONS

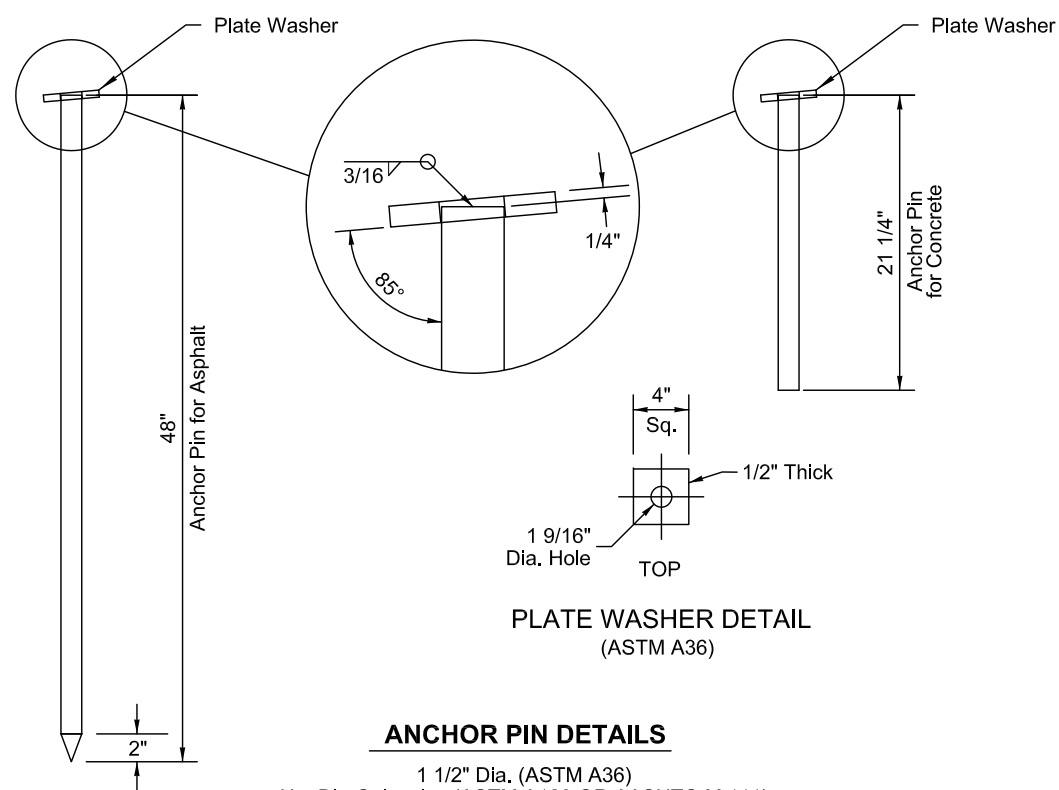

ANCHOR PIN DETAILS

1 1/2" Dia. (ASTM A36)
Hot Dip Galvanize (ASTM A123 OR AASHTO M 111)

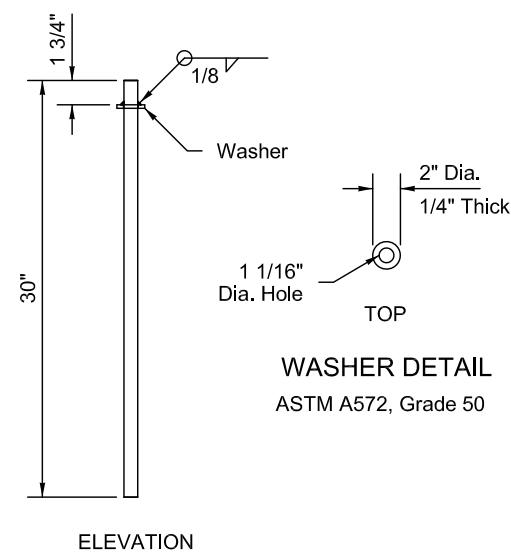

CONNECTING PIN DETAILS

1" Dia. - ASTM A449
Hot Dip Galvanize

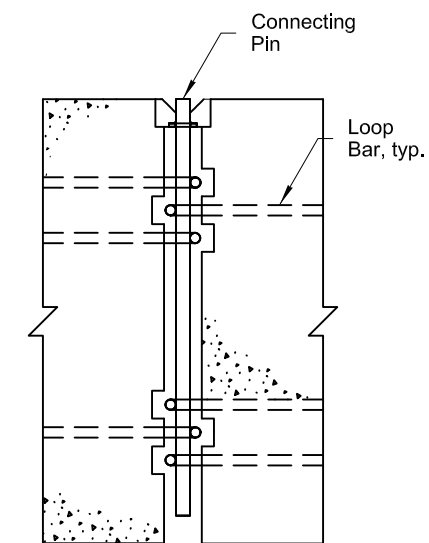

BARRIER CONNECTION DETAIL

Note: Drawing not to scale

State of Alaska DOT&PF
ALASKA STANDARD PLAN

**MASH "F" SHAPE
CONCRETE BARRIER**

Adopted as an Alaska Standard Plan by: *Carolyn Morehouse*
Carolyn Morehouse, P.E.
Chief Engineer

Adoption Date: 07/17/2020

Last Code and Stds. Review
By: LRG Date: 07/17/2020

Next Code and Standards Review date: 07/17/2030

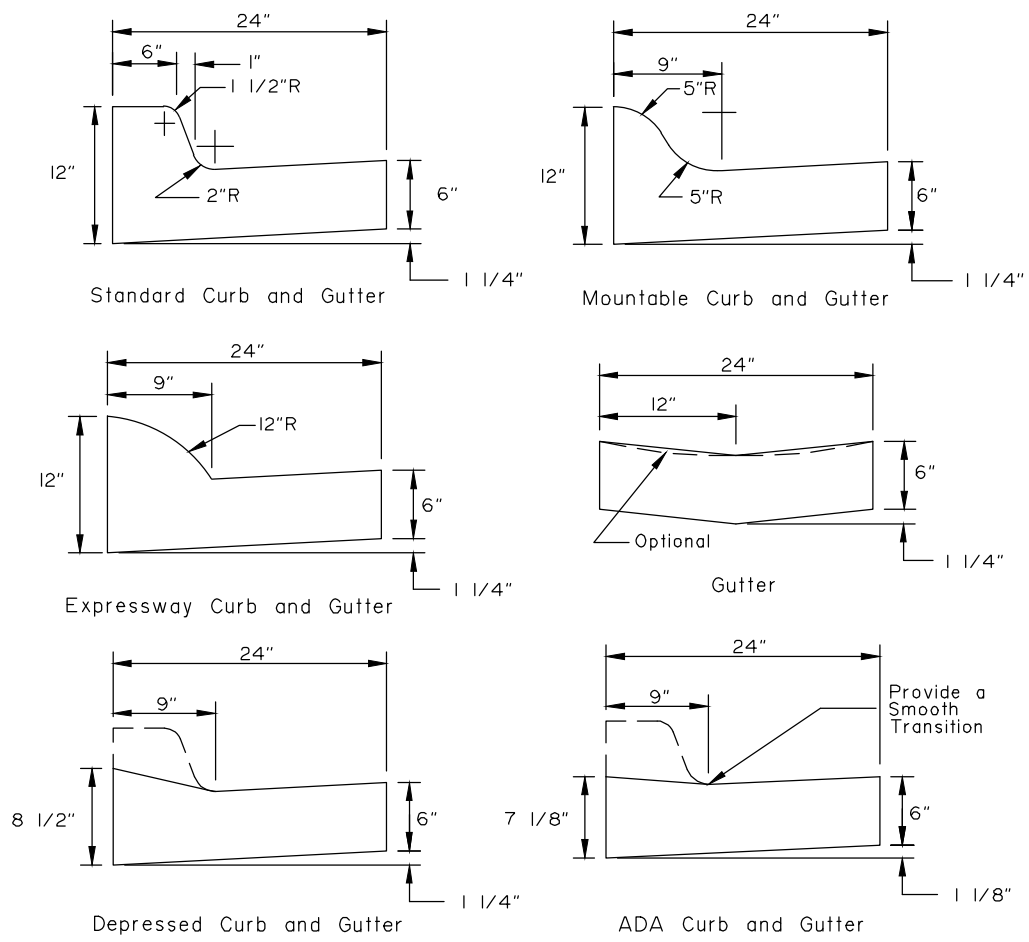

CURB and GUTTER DETAILS

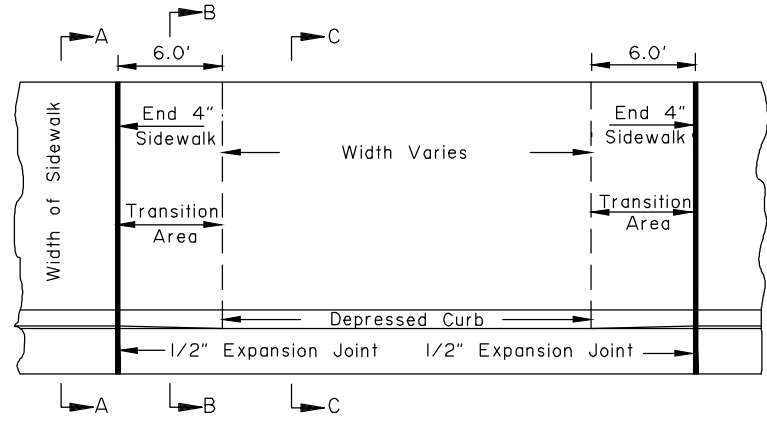

DRIVEWAY CURB CUT DETAILS

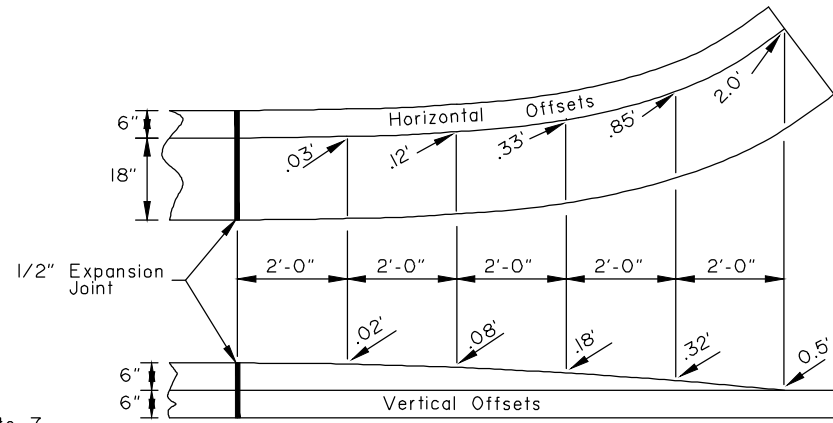
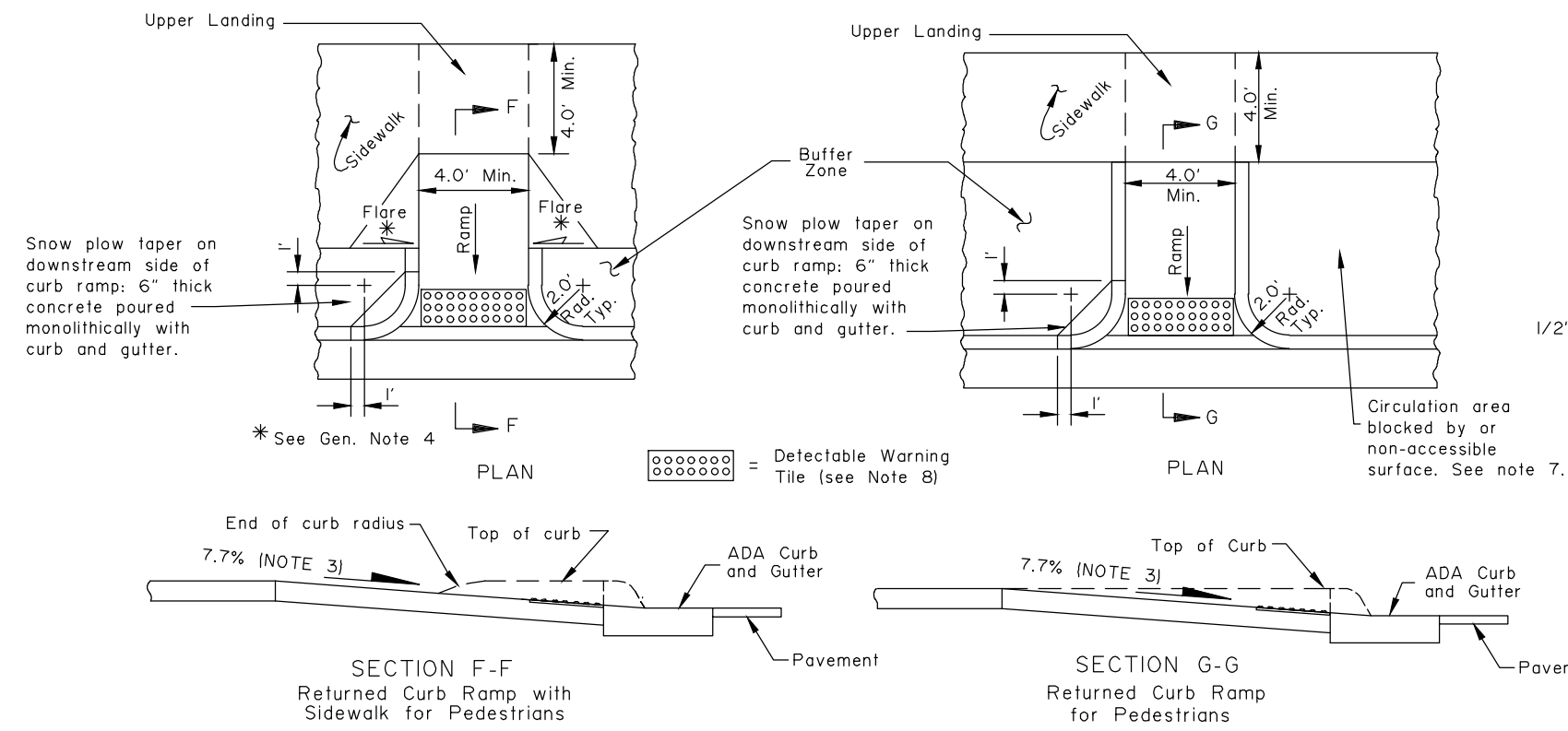
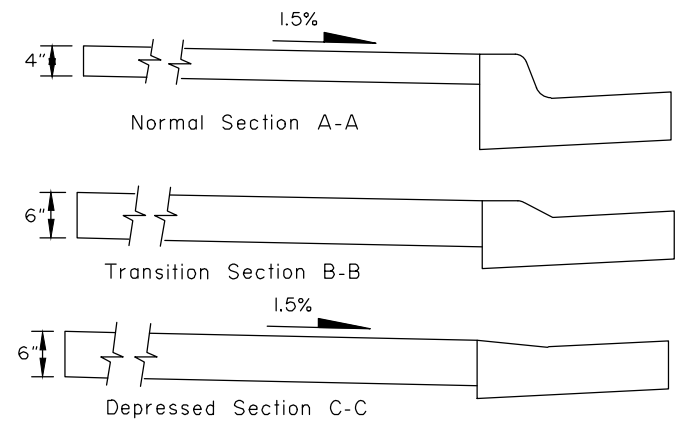

CURB and GUTTER TERMINATION TRANSITIONS

CONSTRUCTION NOTES:

1. Use the type of curb and gutter shown on the plans.
2. Construct ramp runs and landings of concrete, regardless of whether the sidewalk is asphalt or concrete.
3. Construct ramp slopes at a 7.7% nominal grade, or flatter. Ramp slopes may be increased to a maximum of 8.3% when site conditions warrant it. Ramp lengths should be increased to keep grades under the 8.3% maximum, but are not required to exceed 15.0 feet. The resulting ramp grade at a 15.0 foot ramp length is acceptable even if it exceeds 8.3%.
4. Construct flare slopes at 8.3% (measured parallel to the curb line) or flatter, sidewalk cross slopes at 1.5% nominal (1.0% min. and 2.0% max), and ADA Curb and Gutter gutter pan slopes at 4.7% nominal. Construct grade breaks perpendicular to ramp runs.
5. Do not construct flare slopes steeper than 10.0%, sidewalk cross slopes steeper than 2.0% and ADA Curb and Gutter gutter pan slopes steeper than 5.0%. These are the steepest slopes allowed under the 2006 ADA Standards for Transportation Facilities.
6. Provide a coarse broomed finish on ramp runs perpendicular to the ramp slope.
7. When approved by the Engineer, curb returns may be replaced with flares at locations where access to the side of a ramp run is free of poles, utility boxes, other obstructions, or non-accessible surfaces such as a dirt planter strips. See Standard Plan I-22 for flare details.
8. Install 24" wide detectable warning tiles for the full width of the ramp. Provide tiles with truncated domes meeting Section 705.1 of the 2006 ADA Standards for Transportation Facilities. Align truncated dome pattern in the predominant direction of wheelchair travel to permit wheels to roll between domes.
9. Maximum cross slope on upper landings, measured in any direction, is 2.0%. Maximum cross slope on ramps is 2.0% measured perpendicular to the ramp run.

State of Alaska DOT&PF
ALASKA STANDARD PLAN

**CURB CUT
CURB & GUTTER
AND CURB RAMP DETAILS**

Adopted as an Alaska Standard Plan by: *Carolyn Morehouse*
Carolyn Morehouse, P.E.
Chief Engineer

Adoption Date: 7/17/2020

Last Code and Stds. Review
By: KLH Date: 7/8/2020

Next Code and Standards Review date: 7/8/2030

Note: Drawing not to scale

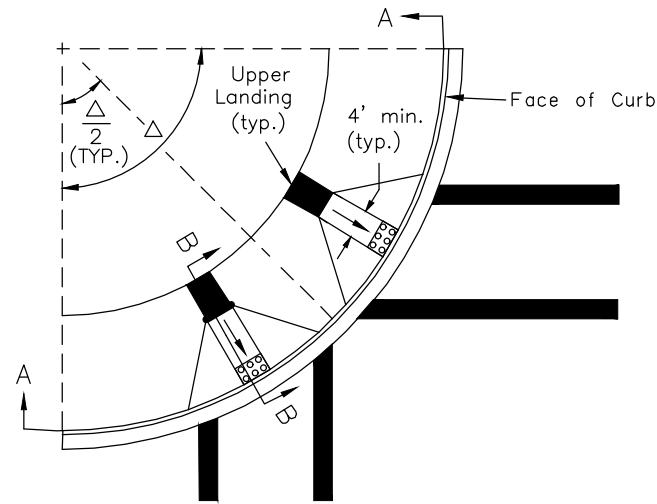

TWO CROSSING DIRECTIONS
At corner

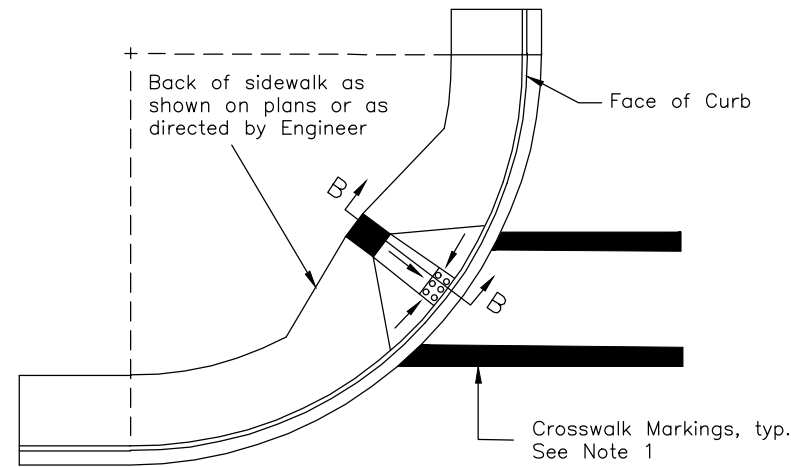

ONE CROSSING DIRECTION
At corner

= Detectable Warning Tile
See Note 9

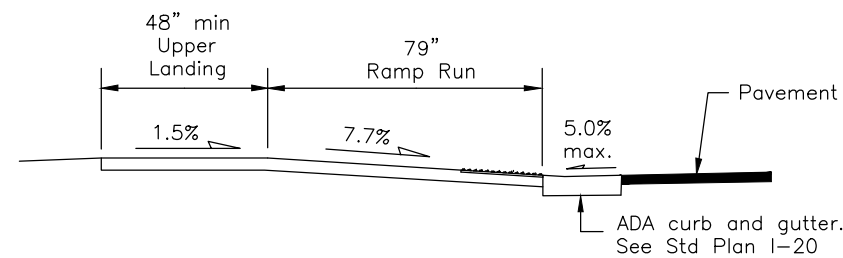

SECTION B-B

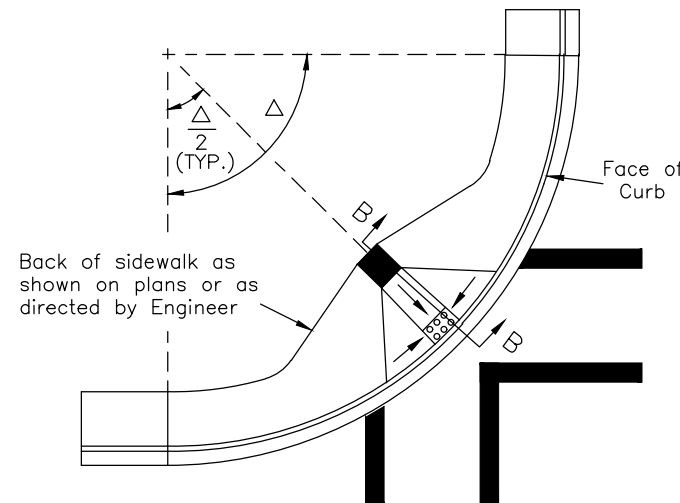

ONE RAMP - TWO DIRECTIONS
At corner

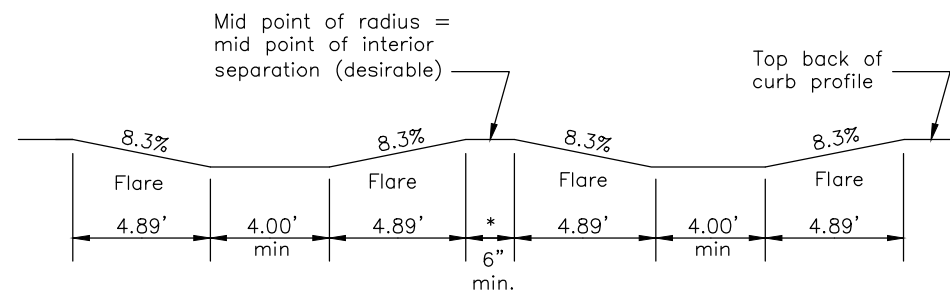

PROFILE A-A

* This dimension is adjustable depending on the curb radius and location of ramps

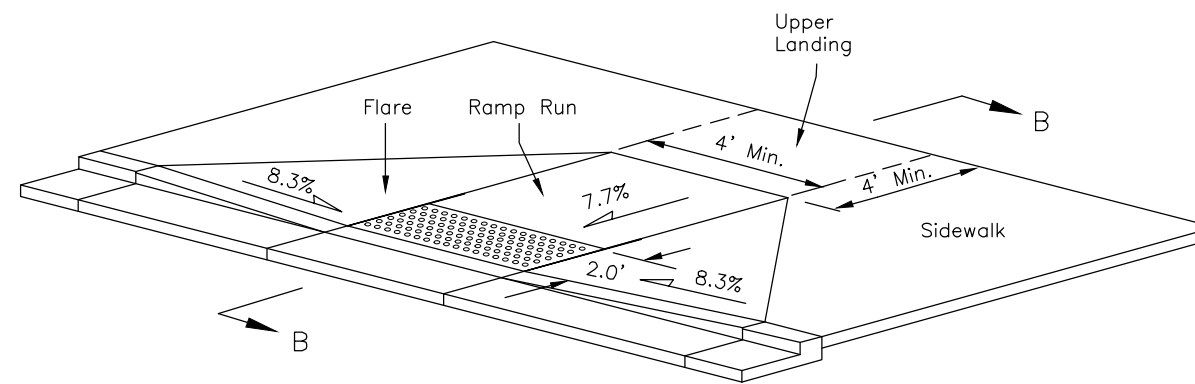

MID-BLOCK

CONSTRUCTION NOTES

1. See plans for ramp type at specific locations. See striping plans for crosswalk layouts.
2. Construct ramp runs perpendicular to the curb face.
3. Construct ramp runs, flares, and upper landings of concrete, regardless of whether the sidewalk is asphalt or concrete.
4. Ramp run and flare lengths are shown for a flat sidewalk grade. For other sidewalk grades, increase or decrease ramp and flare lengths to maintain the slopes shown.
5. Construct ramp slopes at a nominal 7.7% grade, or flatter. Ramps slopes may be increased to a maximum of 8.3% when site conditions warrant it. Ramp lengths should be increased to keep grades under the 8.3% maximum, but are not required to exceed 15.0 feet. The resulting ramp grade at a 15.0 foot ramp length is acceptable even if it exceeds 8.3%.
6. Construct flare slopes at 8.3% (measured parallel to the curb line adjacent to the top back of curb) or flatter, and sidewalk cross slopes at a nominal 1.5% (1.0% min., 2.0% max). Do not construct flare slopes steeper than 10.0%, or sidewalk cross slopes steeper than 2.0%.
7. Provide a coarse broomed finish running parallel to the curb on ramp runs and flares.
8. When approved by the Engineer, flares may be replaced with a curb at locations where access to the side of a ramp run is blocked by poles, utility boxes, other obstructions, or by a non-accessible surface such as a dirt planter strip. See Standard Plan I-20 for details.
9. Install 24" detectable warning tiles for the full width of the ramp. Provide tiles with truncated domes meeting Section 705.1 of the 2006 ADA Standards for Transportation Facilities.
10. Maximum cross slope on upper landings, measured in any direction, is 2.0%. Maximum cross slope on ramps is 2.0% measured perpendicular to the ramp run.
11. Provide 4" minimum thick concrete on ramps, flares and landings

Note: Drawing not to scale

State of Alaska DOT&PF
ALASKA STANDARD PLAN

PERPENDICULAR
CURB RAMP

Adopted as an Alaska
Standard Plan by: *Carolyn Morehouse*
Carolyn Morehouse, P.E.
Chief Engineer

Adoption Date: 7/17/2020

Last Code and Stds. Review
By: KLH Date: 7/8/2020

Next Code and Standards Review date: 7/8/2030

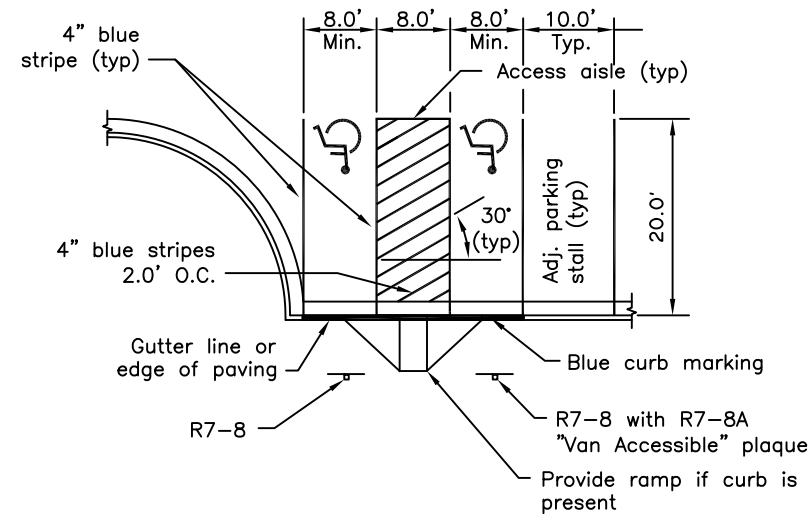

PARKING LOT ACCESSIBLE PERPENDICULAR PARKING

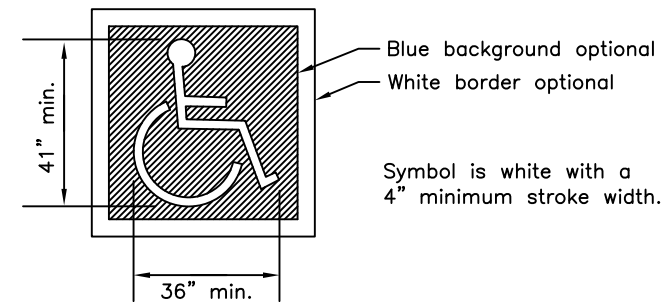

PAVEMENT MARKING SYMBOL DETAIL

GENERAL NOTES:

1. Accessible aisles and accessible routes and those pathways leading from the accessible parking space to the sidewalk shall be free of any obstructions, fixtures or loose surfaces.
2. See standard drawing I-20, I-21, I-22 for curb and curb ramp details.
3. All curb ramps shall be constructed of concrete.
4. The slope for all accessible parking spaces, van accessible parking spaces and access aisles shall not exceed 50:1 in any direction.
5. Although only perpendicular ramps are shown, either parallel or perpendicular ramps are allowable, space permitting.

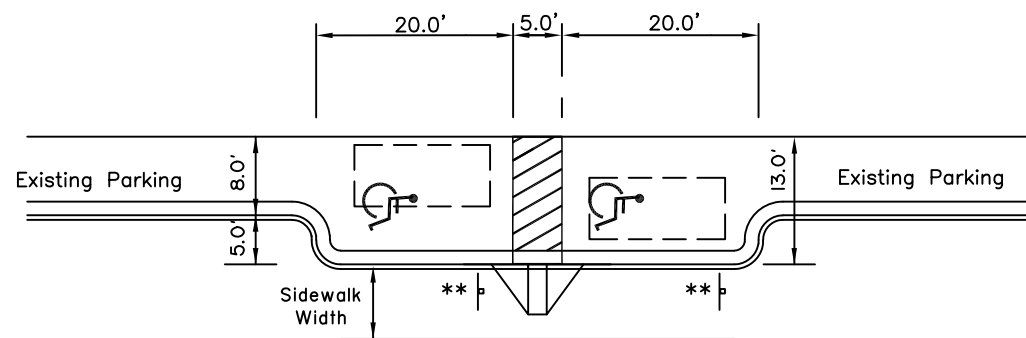

ACCESSIBLE ON-STREET PARALLEL PARKING PARTIAL INSET

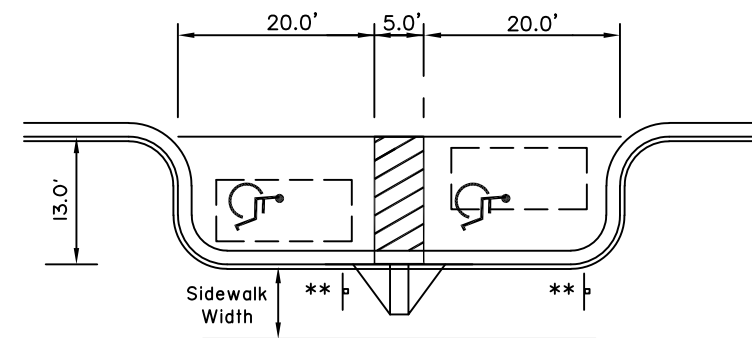

ACCESSIBLE ON-STREET PARALLEL PARKING FULL INSET

ON-STREET PARALLEL PARKING NOTES

1. The 13' width provides for 8' wide parking with a 5' wide access aisle on either side of a car.
2. Add a new curb ramp and 5' aisle between parking places for each additional two accessible parking spaces.
3. Parking spaces may be made van accessible by providing an unobstructed 8' sidewalk width next to each parking space. Ensure curb ramps, parking meters, sign posts, etc. do not encroach on the area where a van's lift would operate.
4. In some cases, ADAAG may allow normal-width parking spaces at the beginning and end of blocks to be designated as accessible. See the latest ADAAG.

** R7-8 "Reserved Parking" and, where appropriate (see note 3), R7-8A, "Van Accessible".

State of Alaska DOT&PF
ALASKA STANDARD PLAN

ACCESSIBLE PARKING

Adopted as an Alaska Standard Plan by: *Kenneth J. Fisher*
Kenneth J. Fisher, P.E.
Chief Engineer

Adoption Date: 02/08/2019

Last Code and Stds. Review By: Date:

Next Code and Standards Review date: 02/08/2029

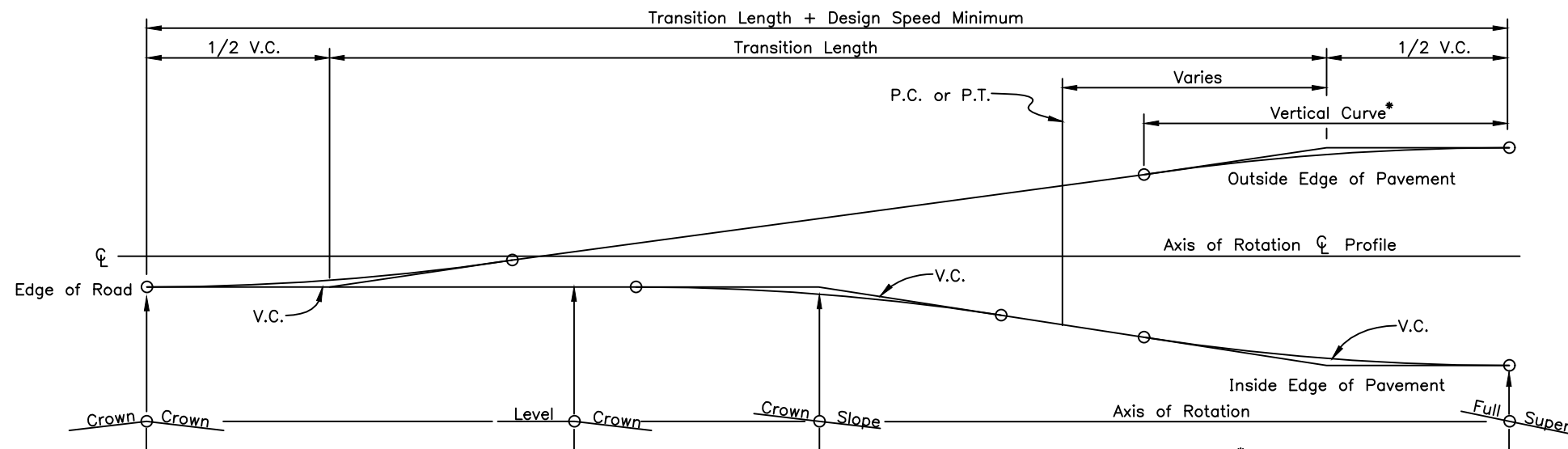

CASE I
PAVEMENT REVOLVED ABOUT CENTERLINE

*See General Note 3

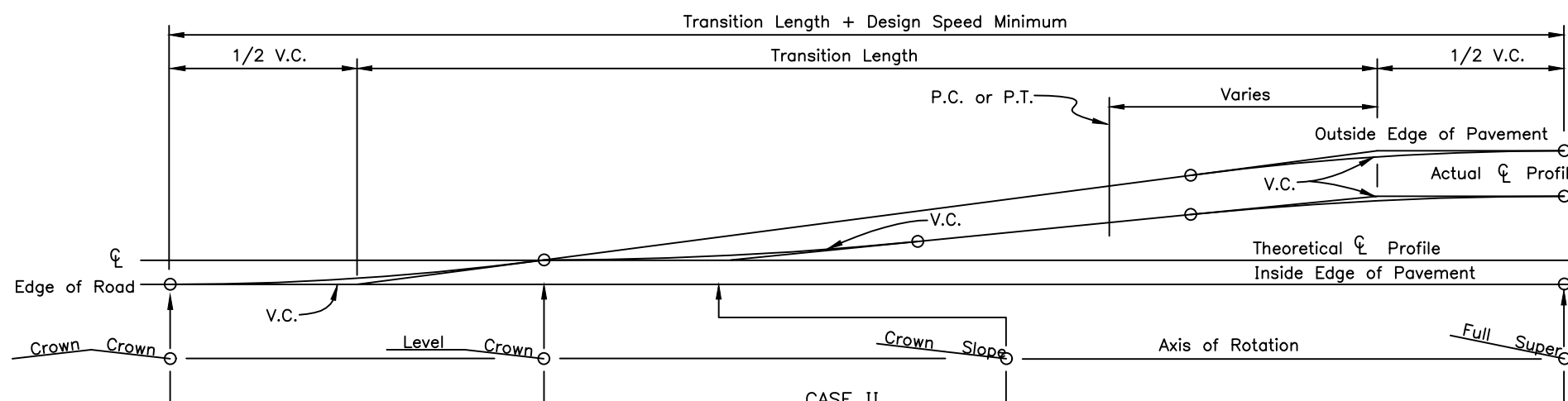

CASE II
PAVEMENT REVOLVED ABOUT INSIDE EDGE
TO BE USED WHERE DRAINAGE IS THE GOVERNING CONSIDERATION

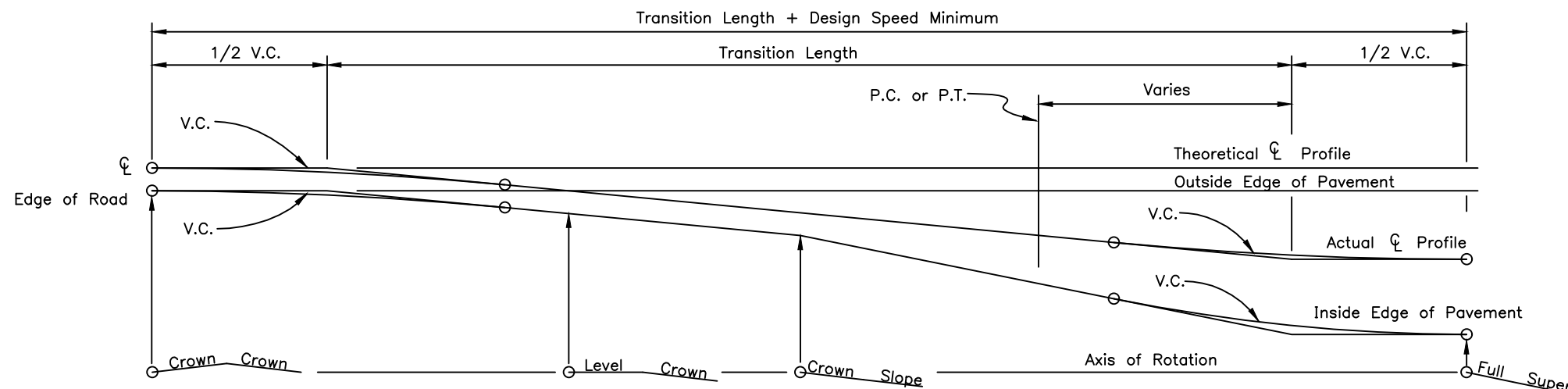

CASE III
PAVEMENT REVOLVED ABOUT OUTSIDE EDGE TO BE
USED WHERE OVERALL APPEARANCE IS THE MAIN CONTROL

GENERAL NOTES:

1. Location of transition length relative to horizontal curves will be shown on the plans or as directed by the Engineer.
2. Widening for guardrail or curvature will not change the location of the axis of rotation.
3. Minimum vertical curve length in feet shall be the numerical value of the design speed in M.P.H.
4. Superelevation shall be built into the subgrade and carried through the shoulders.

State of Alaska DOT&PF
ALASKA STANDARD PLAN

SUPERELEVATION
TRANSITION

Adopted as an Alaska
Standard Plan by: *Carolyn Morehouse*
Carolyn Morehouse, P.E.
Chief Engineer

Adoption Date: 7/17/2020

Last Code and Stds. Review
By: KLK Date: 7/8/2020

Next Code and Standards Review Date: 7/8/2030

I-81.00

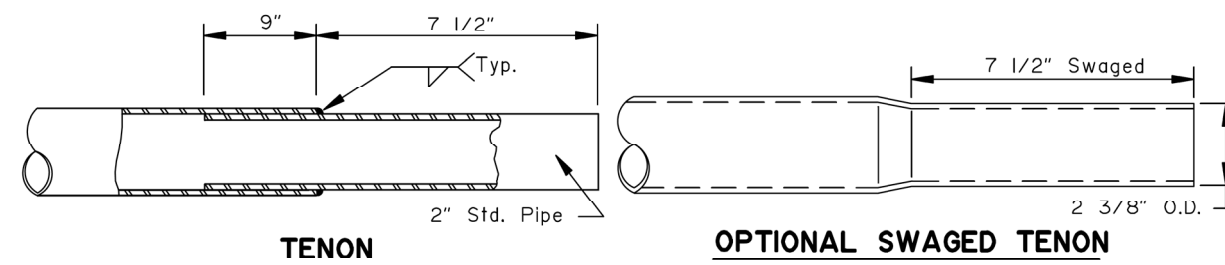
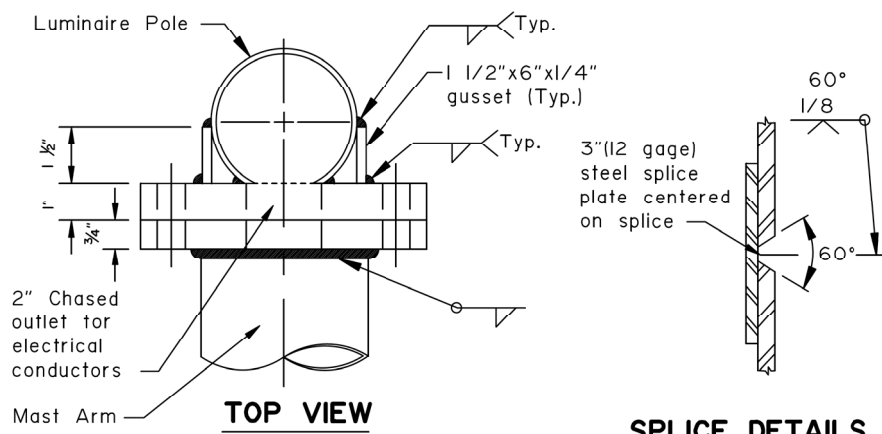

END OF MAST ARM DETAIL

GENERAL NOTES:

- Design and fabricate Lighting Standards according to AASHTO LTS-6-13, 2019 and 2020 Interim Revisions to (2013 Sixth Edition) Standard Specifications for Structural Supports for Highway Signs, Luminaires, and Traffic Signals. Fatigue and temporary loads are not to be considered.
- Weld size to be determined by manufacturer.
- Mounting height, if specified in the plans, refers to the height of luminaire above the finished roadway surface. Adjust each pole's shaft length to maintain this difference in elevation whenever slope and/or offset varies.
- Minimum outside diameter at the top of pole equals 3-7/8". Pole diameter shall taper uniformly from the top of pole to the base plate, with a minimum taper rate of 0.14" per foot.
- Mast arm rise may vary ±0.5ft from the values listed in the table.
- Locate the handhole at 90 degrees to the mast arm on the side of pole downstream from traffic flow.
- Furnish all poles with a j-hook to support the illumination tap conductors. Furnish all mast arm poles with a removable raintight cap.
- See ASP L-30 for frangible coupling and skirt details and notes.

MAST ARM DATA		
ARM LENGTH	ARM RISE	SHAFT LENGTH (MAX)
22'-4"	6'-0"	40'
20'-4"	5'-6"	42'
18'-4"	4'-6"	44'
15'-4"	4'-3"	46'
12'-4"	3'-6"	49'
10'-4"	2'-6"	51'
8'-4"	2'-3"	53'
6'-4"	1'-6"	55'
4'-4"	1'-3"	55'
TENON MOUNT		55'

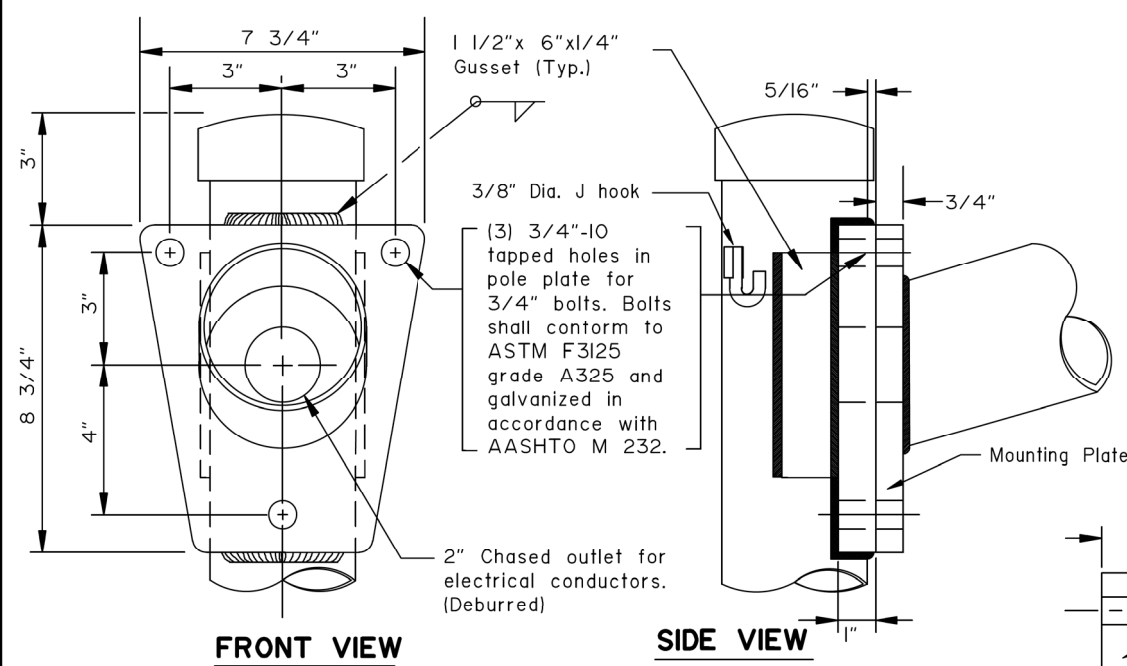

MAST ARM CONNECTION DETAIL

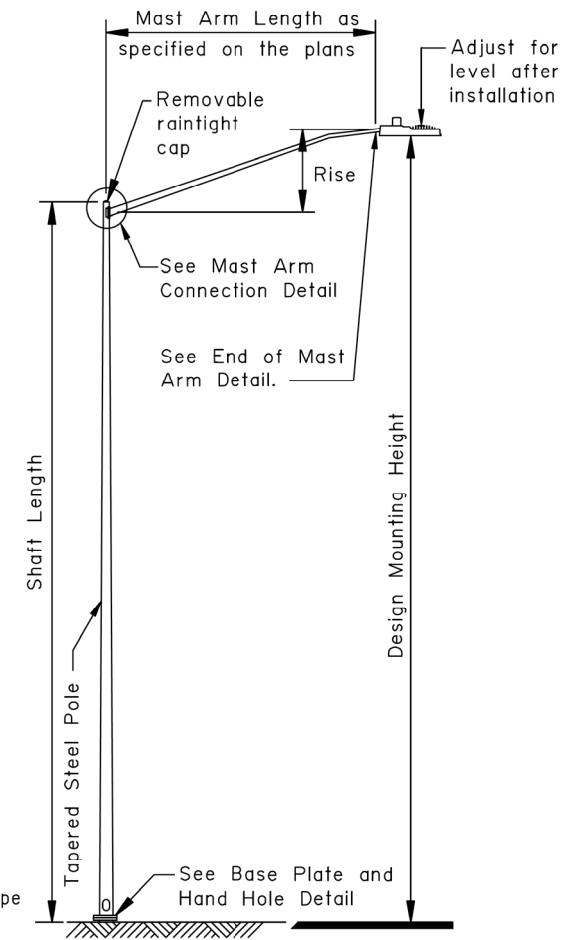

**ELECTROLIER ELEVATION
COBRA HEAD**

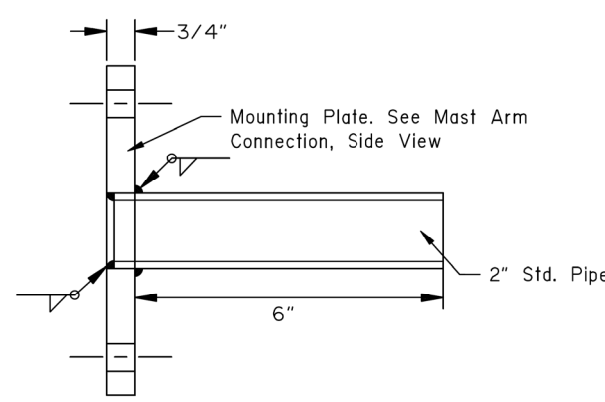

TENON MOUNT DETAIL

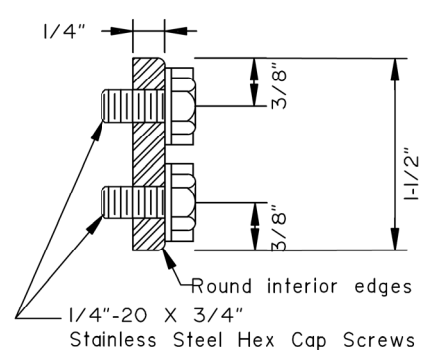
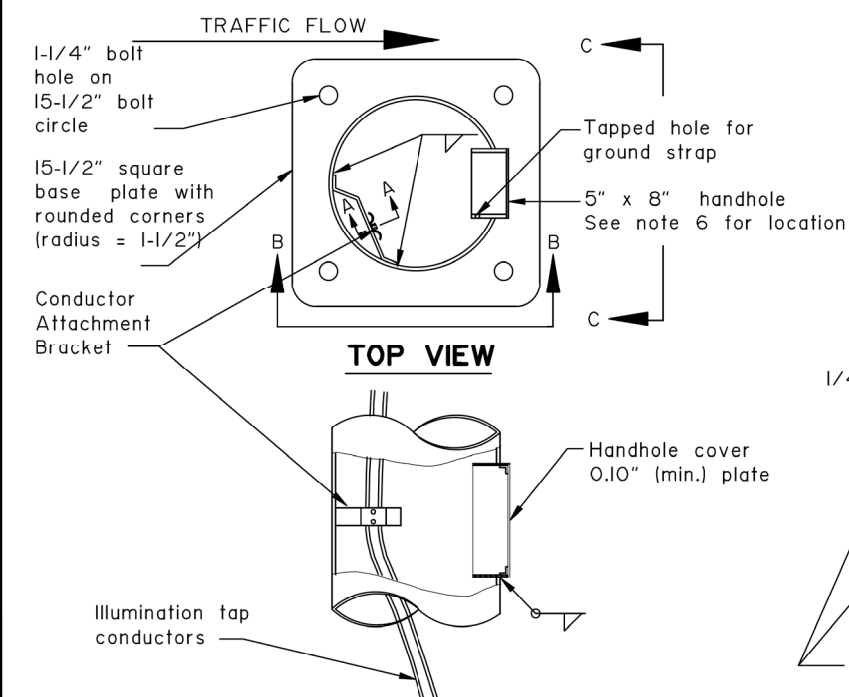

SECTION A-A

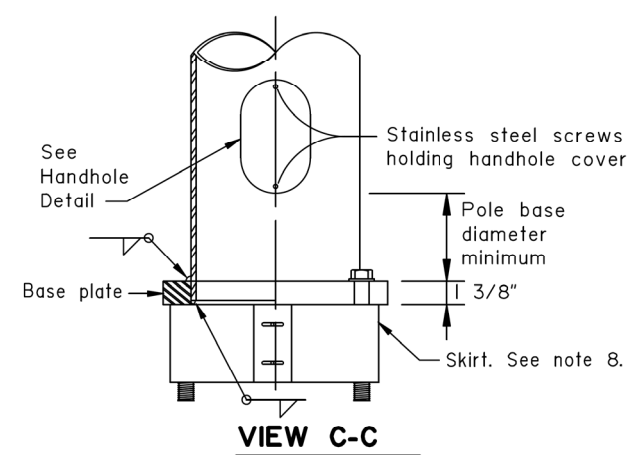
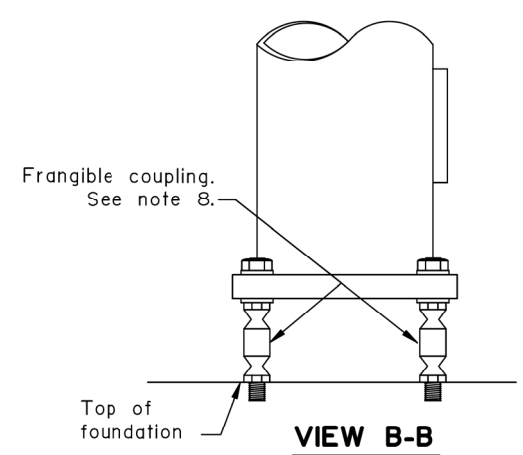

State of Alaska DOT&PF
ALASKA STANDARD PLAN
LIGHTING STANDARDS

Adopted as an Alaska Standard Plan by:
Lauren Little, P.E.
Interim Chief Engineer

Adoption Date: 01/29/2024
Last Code and Stds. Review By: CMW Date: 12/19/2023
Next Code and Standards Review Date: 12/19/2033

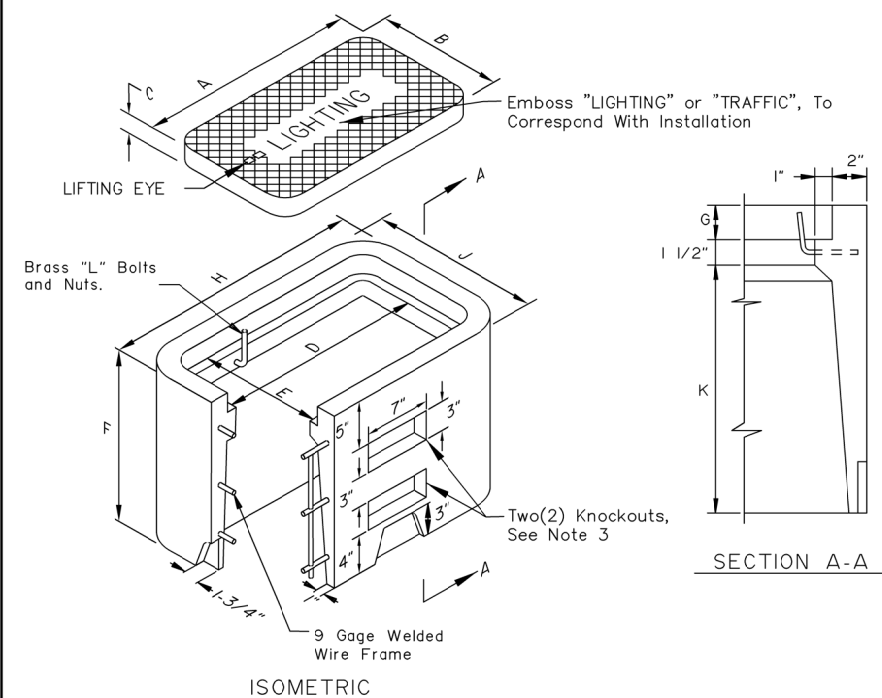

ISOMETRIC

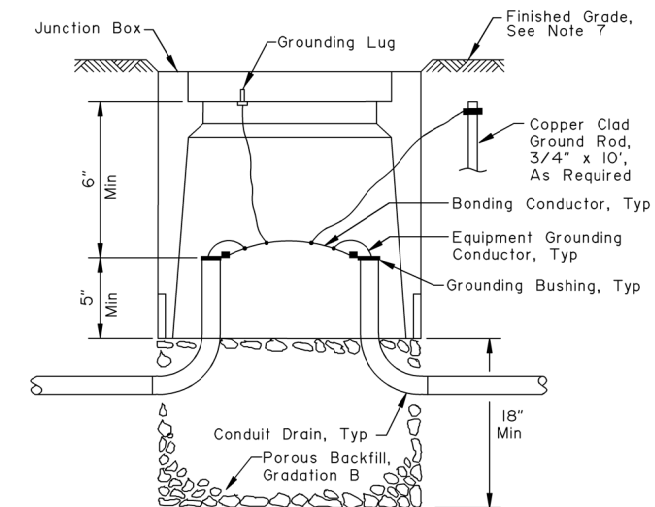

ELEVATION

TYPE I & IA JUNCTION BOX

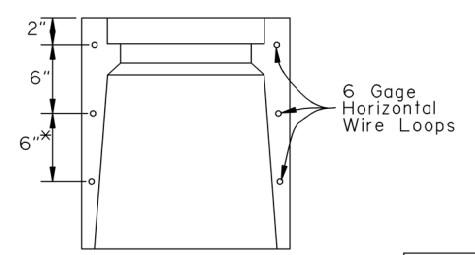

ALTERNATE REINFORCING
*Type IA Only

DIMENSIONS (IN)		
	TYPE I	TYPE IA
A	15	22 3/4
B	10	13 1/4
C	1 3/4	2
D	13 1/2	21 1/4
E	8 1/2	11 3/4
F	12	18
G	1 3/4	2
H	19 1/2	27 1/4
J	14 1/2	17 3/4
K	8 3/4	14 1/2

DIMENSIONS (IN)			
	TYPE II	TYPE III	TYPE IV
A (Max)	30	30	30
B (Max)	30	30	36
C (Min)	22	22	30
D (Min)	22	22	24
E (Min)	24	24	30

- GENERAL NOTES:**
- See the Standard Specifications for Highway Construction (SSH) for additional requirements.
 - See Section 660-2.01 of the SSHC for concrete and reinforcing steel requirements.
 - Provide knockouts indicated in Type IA junction box when installed for loop detection. Conduit for loop detectors to enter junction box through knockouts.
 - Covers for junction boxes shall be cast iron. Type I and IA shall be secured to junction box with a minimum of two bolts and be rated ANSI/SCTE 77, Tier 8, minimum. Type II, Type III and Type IV cover shall weigh over 100 pounds and be ANSI/SCTE 77, AASHTO H-20 traffic rated.
 - The minimum required bearing capacity for Type I shall be 6,800psf, for Type IA shall be 5,100psf, for Type II shall be 3,500psf, for Type III shall be 2,300psf, and for Type IV shall be 2,000psf.
 - See section 703-2.10 of the SSHC for Porous Backfill material requirements.
 - See section 660-3.04 of the SSHC for top of junction box placement to finished grade requirements.
 - Provide conduits as required, size and quantity indicated in plans.
 - Provide grout around conduits in knockouts and for unused knockouts.
 - Provide a 1/2" thick preformed bituminous joint material around junction boxes installed in concrete walkways.
 - Met' conduits and junction box covers shall be bonded together to be electrically continuous using No. 8 AWG minimum copper bonding conductor. Cover shall be bonded using a finned copper braided bonding jumper.

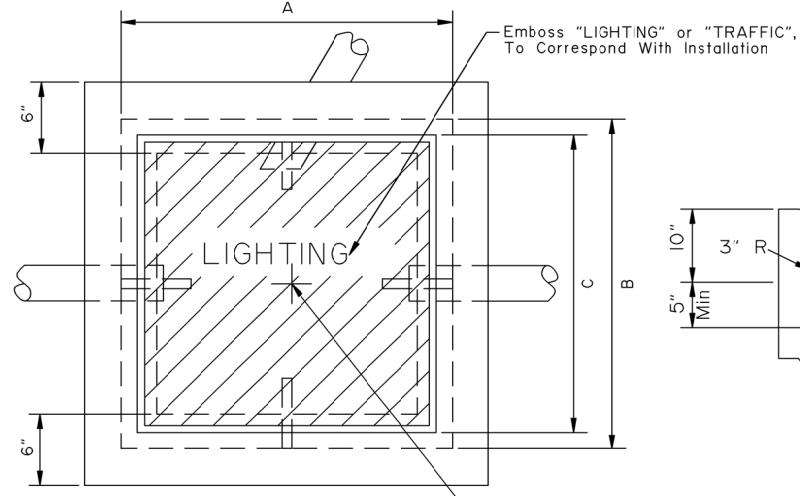

PLAN

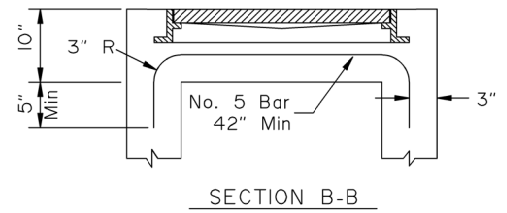

SECTION B-B

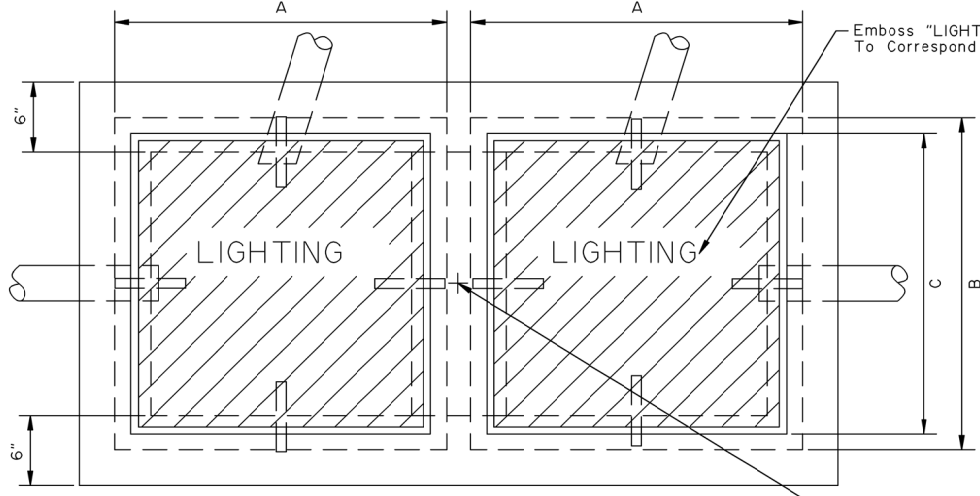

PLAN

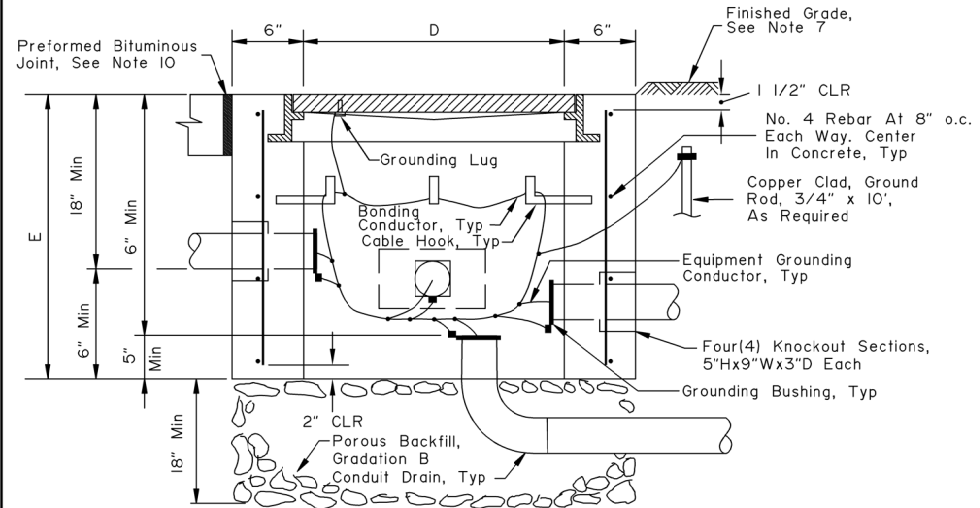

ELEVATION

TYPE II JUNCTION BOX

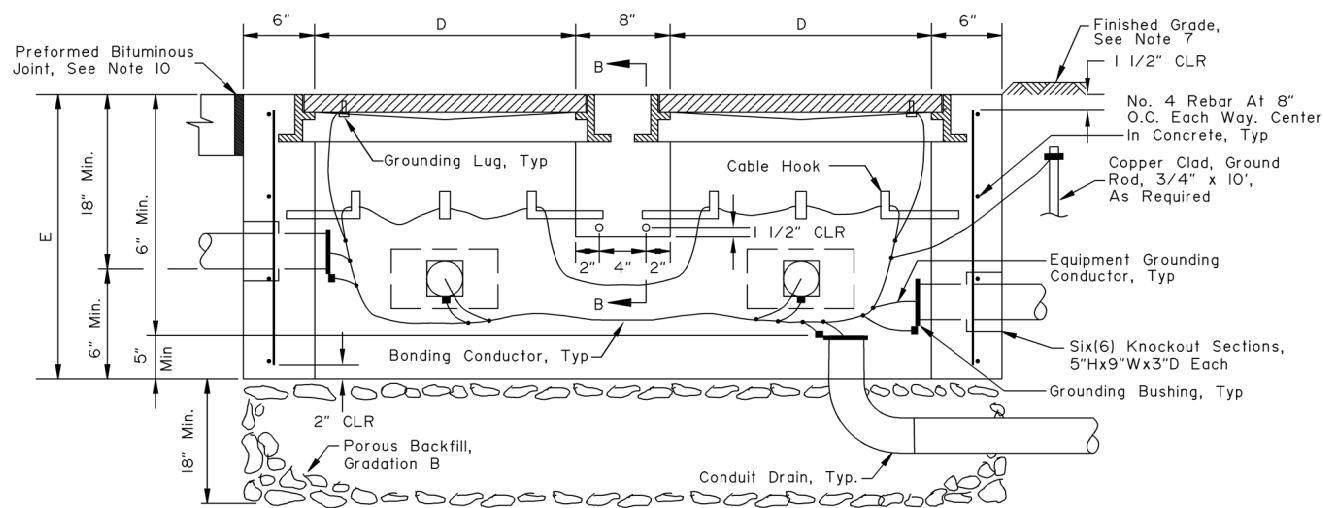

ELEVATION

TYPE III & IV JUNCTION BOX

NOT TO SCALE

State of Alaska DOT&PF
ALASKA STANDARD PLAN

JUNCTION BOXES
FOR ELECTROLIER
& TRAFFIC SIGNALS

Adopted as an Alaska Standard Plan by *Carolyn H. Morehouse*
Carolyn Morehouse, P.E.
Chief Engineer

Adoption Date: 09/15/2022

Last Code and Stds. Review
By: CNH Date: 7/15/2020

Next Code and Standards Review date: 7/15/2030

L-23.03

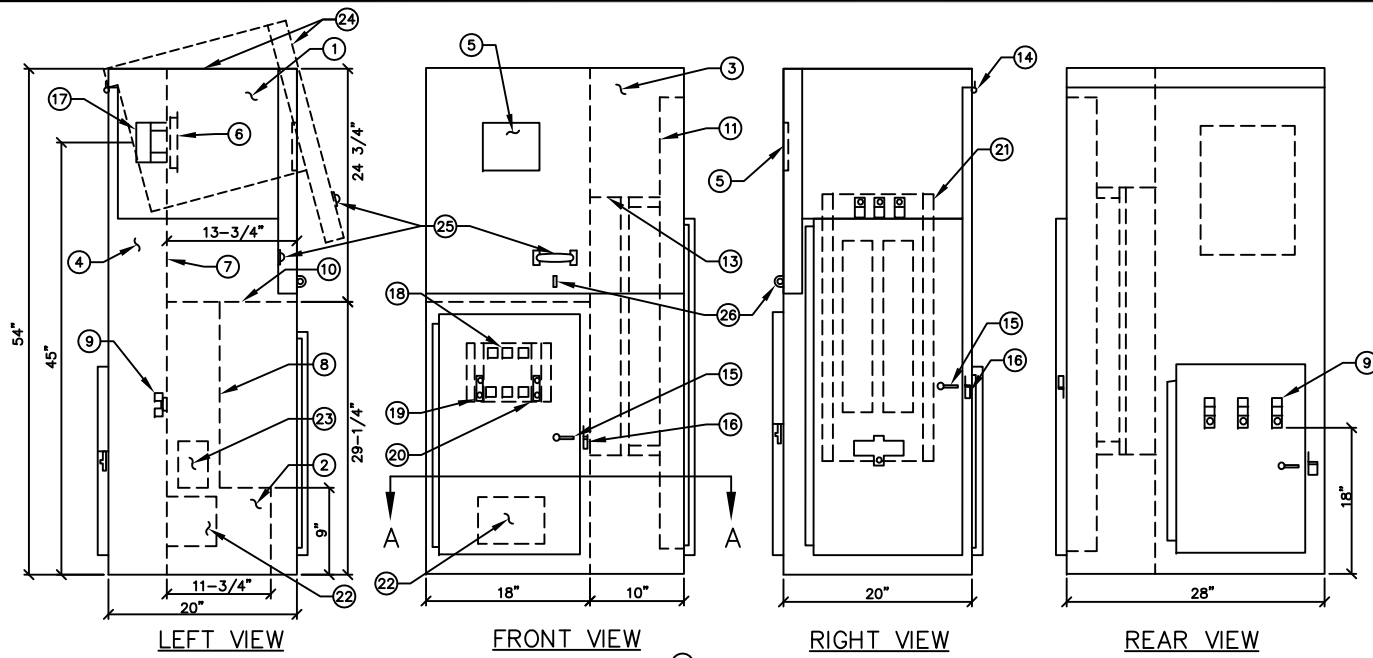

- EQUIPMENT LEGEND**
- METER SECTION
 - LOAD SECTION (MAIN)
 - LOAD SECTION (DISTRIBUTION)
 - SERVICE PULL SECTION
 - METER READING WINDOW
 - METER SOCKET COVER
 - TEST SECTION COVER
 - DEAD FRONT
 - UTILITY LANDING LUGS
 - METER SECTION BARRIER
 - PANEL BOARD DEADFRONT
 - EQUIPMENT CHASSIS
 - MOUNTING PAN

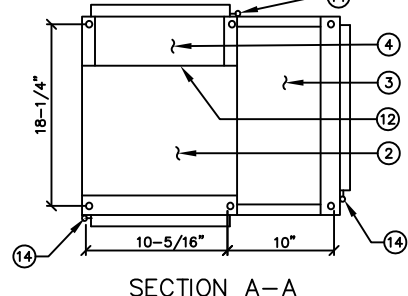

- STAINLESS STEEL PIN HINGE
- COIN LATCH
- HASP FOR PADLOCK
- METER SOCKET KIT ASSEMBLY
- MAIN BREAKER(S)
- NEUTRAL BAR
- GROUND BAR
- PANEL BOARD INTERIOR
- ALTERNATE CONTACTOR LOCATION
- CABLE OPENING
- HINGED HOOD
- HOOD HANDLE
- SEALABLE PADLOCK HASP

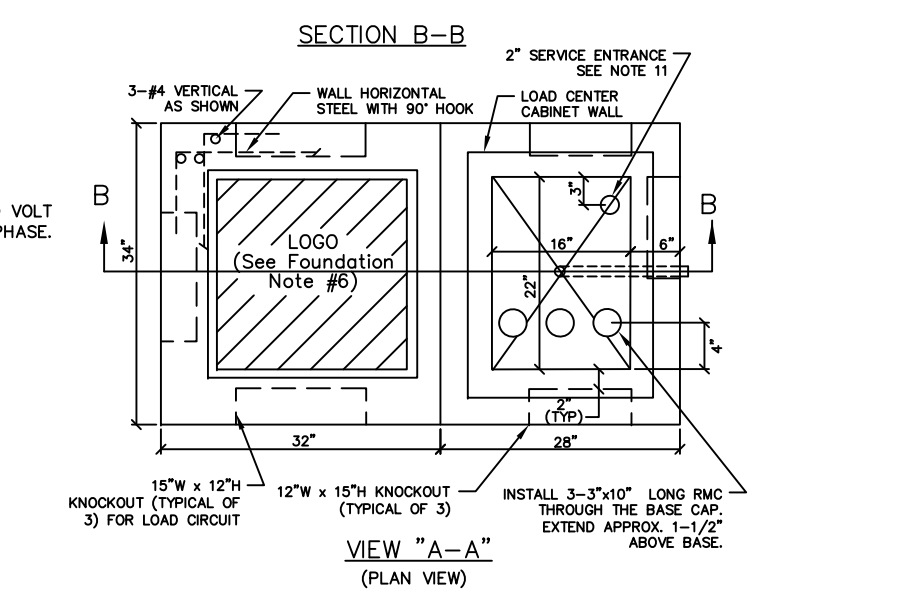
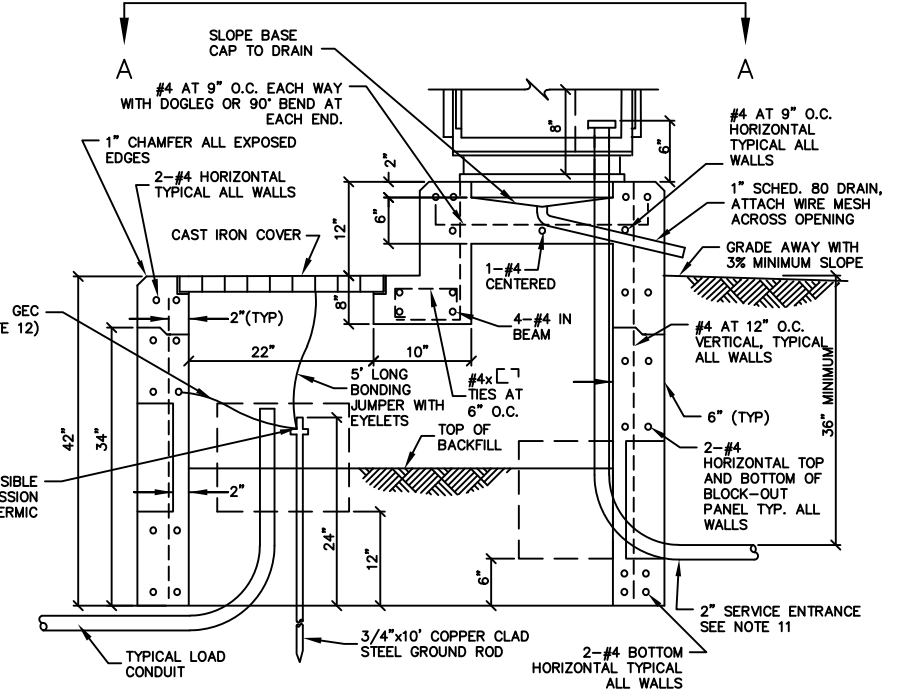
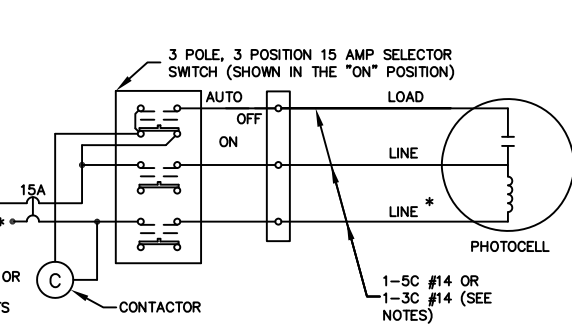
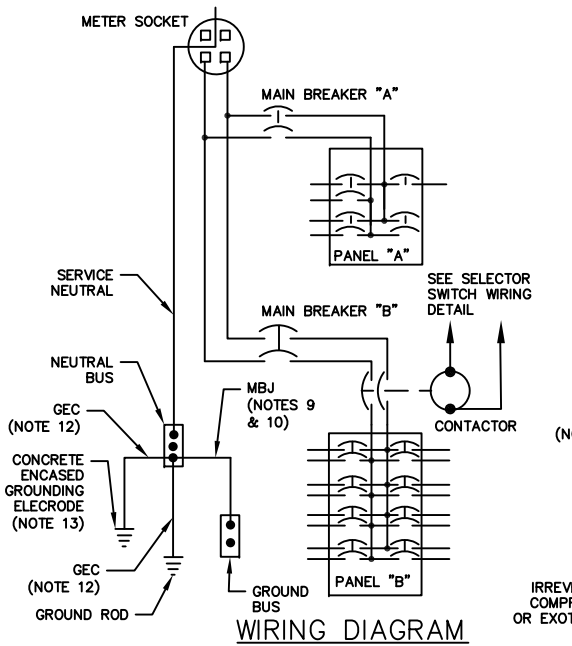
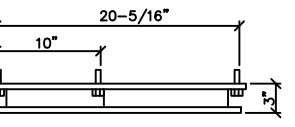

TYPE 1 LOAD CENTER CABINET SECTION / ELEVATION

FOUNDATION NOTES:

- INSTALL THE SURFACE WITH CAST IRON COVER FLUSH WITH THE PAVEMENT, SIDEWALK, OR FINISHED GRADE. GRADE AWAY FROM THE BASE WITH A MINIMUM SLOPE OF 3%. USE A PRE-MOULDED BITUMINOUS JOINT BETWEEN THE BASE AND CONCRETE SIDEWALK OR PAVING.
- WHEN INSTALLING THE BASE, EXCAVATE TO 60" BELOW FINISHED GRADE AND INSTALL A DRAIN CONSISTING OF 18" OF COARSE CONCRETE AGGREGATE APPROVED BY THE ENGINEER. BACKFILL AROUND THE BASE IN 6" LIFTS WITH SELECTED MATERIAL TYPE "A".
- BACKFILL INSIDE THE FOUNDATION TO WITHIN 24" OF THE LID AFTER ALL CONDUITS ARE INSTALLED, USING COARSE AGGREGATE. TERMINATE THE ENDS OF ALL LOAD CONDUITS A MINIMUM OF 6" ABOVE THE COARSE CONCRETE AGGREGATE BACKFILL AND A MINIMUM OF 12" BELOW THE LID.
- PROVIDE ANCHOR BOLTS OR EXPANSION ANCHORS IN THE BASE FOR MOUNTING THE CABINET PER THE MANUFACTURER'S SHOP DRAWINGS. ANCHOR BOLTS, NUTS, AND WASHERS SHALL CONFORM TO EITHER ASTM A307 OR A449 AND SHALL BE GALVANIZED IN ACCORDANCE WITH ASTM A153.
- USE GRADE 60 REINFORCING STEEL CONFORMING TO ASTM 615 AND CLASS "A" CONCRETE CONFORMING TO SECTION 501 OF THE SPECIFICATIONS WHEN CASTING THE BASE.
- FINISH THE BASE ACCESS OPENING WITH A 24" SQUARE IRON FRAME AND COVER WITH PICK HOLE FOR REMOVAL, WEIGHING APPROXIMATELY 280 LBS. PROVIDE COVERS INSCRIBED WITH THE LEGEND "LIGHTING" FOR THOSE LOAD CENTERS WITH STREET LIGHTING CIRCUITS ONLY, AND "TRAFFIC" FOR THOSE LOAD CENTERS WITH A TRAFFIC SIGNAL CIRCUIT.
- IF THE BASE IS PRECAST, INSTALL TWO 3/4" FERRULE LOOP INSERTS IN TWO SIDES OPPOSITE ONE ANOTHER FOR LIFTING.

NOTES:

- FURNISH ALL EQUIPMENT NOTED IN THE LOAD CENTER SUMMARY(IES) IN THE PLANS, PLUS TWO 20-AMP 2-POLE SPARE CIRCUIT BREAKERS, AND SPACE FOR A MINIMUM OF TWO ADDITIONAL 2-POLE CIRCUIT BREAKERS IN EACH LOAD PANEL. SEE THE LOAD CENTER SUMMARIES FOR LOAD PANEL VOLTAGES, CURRENT RATINGS, SHORT CIRCUIT INTERRUPTING RATINGS, AND THE NAME OF THE SERVING UTILITY.
- INSTALL GROUNDING HUBS THIRD PARTY CERTIFIED FOR WET LOCATIONS, WHEN ATTACHING CONDUITS TO THE LOAD CENTER ENCLOSURE.
- LABEL ALL CIRCUIT BREAKERS AS TO FUNCTION AND POSITION. LABEL THE SELECTOR SWITCH "LIGHTING" AND ITS POSITIONS "ON-OFF-AUTO".
- INSTALL THE PHOTOELECTRIC CONTROL UNIT ON A 3/4", OR LARGER, CONDUIT. LOCATE THE UNIT 18"-24" ABOVE THE TOP OF THE LOAD CENTER. ORIENT THE CONTROL WINDOW FACING NORTH AND/OR AWAY FROM ARTIFICIAL LIGHT SOURCES THAT MAY INTERFERE WITH AMBIENT LIGHT CONTROL. INSTALL A 3C#14 CABLE FROM THE LOAD CENTER TO THE CONDUIT BODY WHERE THE CONNECTION TO THE PHOTOCELL RECEPTACLE CABLE SHALL BE MADE. IF PLANS CALL TO MOUNT PHOTOCELL AWAY FROM LOAD CENTER USE A 5C#14 CABLE FROM LOAD CENTER TO RECEPTACLE. PHOTOCELL MUST BE ENCLOSED IN A METALLIC ENCLOSURE.
- METER BASES SHALL NOT BE MOUNTED ON MOVABLE PANELS OR DOORS.
- LOCATE THE LOAD CENTER AS SHOWN ON THE PLANS.
- STORE A SCHEMATIC DIAGRAM, A CIRCUIT DIRECTORY, AND A MATERIALS LIST THAT INCLUDES THE MANUFACTURER'S NAME AND PART/CATALOG NUMBERS, ALL LAMINATED IN PLASTIC, IN A METAL POCKET ATTACHED TO THE INSIDE OF THE LOAD CENTER. INSTALL THE POCKET ON THE LOAD CENTER DOOR, PROVIDING DRAIN HOLES TO PREVENT WATER ACCUMULATION.
- MAXIMUM METER HEIGHT SHALL NOT EXCEED 64" FROM CAST IRON COVER TO CENTER OF THE METER SOCKET COVER.
- INSTALL #6 AWG COPPER MAIN BONDING JUMPER, OR SIZE PER NEC TABLE 250.102 (C)(1), WHICHEVER IS LARGER.
- INSTALLATION MUST COMPLY WITH THE NEC 250.24 (C) AND 250.24 (C) EXCEPTION WHEN MORE THAN ONE PANELBOARD IS PRESENT.

NOTES (CONTINUED):

- THE LENGTH AND TYPE OF SERVICE ENTRANCE CONDUIT INSTALLED BY THE CONTRACTOR VARIES BY UTILITY. REGARDLESS OF ITS LENGTH, INSTALL A PULL ROPE IN THE SERVICE CONDUIT AND A CAP ON THE BURIED END: MARK THE BURIED END WITH A 2" X 6" WOOD STAKE. SEE THE LOAD CENTER SUMMARIES FOR THE FOLLOWING INFORMATION.
 - STATION AND OFFSET OF THE LOAD CENTER AND POWER SOURCE.
 - WHERE THE CONTRACTOR TERMINATES THE SERVICE ENTRANCE CONDUIT.
 - THE TYPE OF SERVICE ENTRANCE CONDUIT (SUCH AS RIGID METAL CONDUIT OR LIQUID-TIGHT FLEXIBLE METAL CONDUIT).
- INSTALL #6 AWG COPPER GROUNDING ELECTRODE CONDUCTOR (GEC), OR SIZE PER NEC TABLE 250.66, WHICHEVER IS LARGER.
- THE REINFORCING BARS WITHIN THE CONCRETE PAD MUST BE CONNECTED TOGETHER BY EFFECTIVE MEANS AND WILL BECOME PART OF THE GROUNDING ELECTRODE SYSTEM PER NEC 250.50 AND 250.52(A)(3). INSTALL AN IRREVERSIBLE COMPRESSION GROUNDING CONNECTOR, NRTL-LISTED FOR DIRECT BURIAL IN EARTH AND CONCRETE, TO CONNECT THE REINFORCING BARS TO THE GEC. INSTALL A BARE COPPER GEC, SIZED PER NEC 250.66 BUT NOT SMALLER THAN #6 AWG, BETWEEN THE COMPRESSION CONNECTOR AND THE LOAD CENTER NEUTRAL.
- INSTALL LABEL(S) ON ENCLOSURE EXTERIOR PER ARC FLASH AND SHOCK HAZARD LABELING DETAIL:
 - TO WARN OF THE POTENTIAL ARC FLASH HAZARD [PER NEC 110.16 AND NFPA 70E], AND
 - TO IDENTIFY THE AVAILABLE FAULT CURRENT [PER NEC 110.24(A)].
- WHEN SHOWN IN THE PLANS, INSTALL ENCLOSURE HEATER WITH INTEGRAL THERMOSTAT, SET TO ENERGIZE THE HEATER AT TEMPERATURES AT OR BELOW 32-DEG F. SCHNEIDER ELECTRIC CAT. NO. NSYCRP1W230VTV, NVENT-HOFFMAN CAT. NO. DAH4002B, OR APPROVED EQUAL.
- BOND SERVICE CONDUIT GROUNDING BUSHING TO SUPPLY-SIDE BONDING JUMPER. BOND LOAD CONDUIT GROUNDING BUSHINGS TO ASSOCIATED EQUIPMENT GROUNDING CONDUCTORS (EGC'S).

TYPE 1 LOAD CENTER BASE

NOTE: STOP HORIZONTAL AND VERTICAL STEEL AT BLOCK-OUT PANELS & OPTIONAL JOINT USING 90° BEND. INSTALL 2 EXTRA #4 HORIZONTAL AND VERTICAL BARS ON ALL SIDES OF EACH KNOCKOUT.

**State of Alaska DOT&PF
ALASKA STANDARD PLAN**

TYPE 1 LOAD CENTER

Adopted as an Alaska Standard Plan by: *Carolyn Morehouse*
Carolyn Morehouse, P.E.
Chief Engineer

Adoption Date: 07/17/2020

Last Code and Stds. Review By: JC Date: 07/17/2020

Next Code and Standards Review date: 07/17/2030

EQUIPMENT LEGEND/DESCRIPTION

- | | | | |
|--|--|---|--------------------------|
| 1. METERING SECTION | 5. METER SOCKET W/BYPASS & SAFETY SOCKET | 10. DISTRIBUTION PANEL | 13. SERVICE PULL SECTION |
| 2. LOAD SECTION | 6. LIFT AWAY METER SECTION COVER | 11. MAIN CIRCUIT BREAKER | 14. SELECTOR SWITCH |
| 3. UTILITY CONNECTION AND TEST BLOCK SECTION | 7. DEADFRONT | 12. ACCESSORY EQUIPMENT MOUNTING AREA FOR CONTACTOR, SELECTOR SWITCHES, TERMINAL STRIPS, AND SO ON. | 15. ENCLOSURE HEATER |
| 4. METER READING WINDOW (8"X8") | 8. STAINLESS STEEL PIN HINGE | | |
| | 9. PADLOCKING PROVISIONS | | |

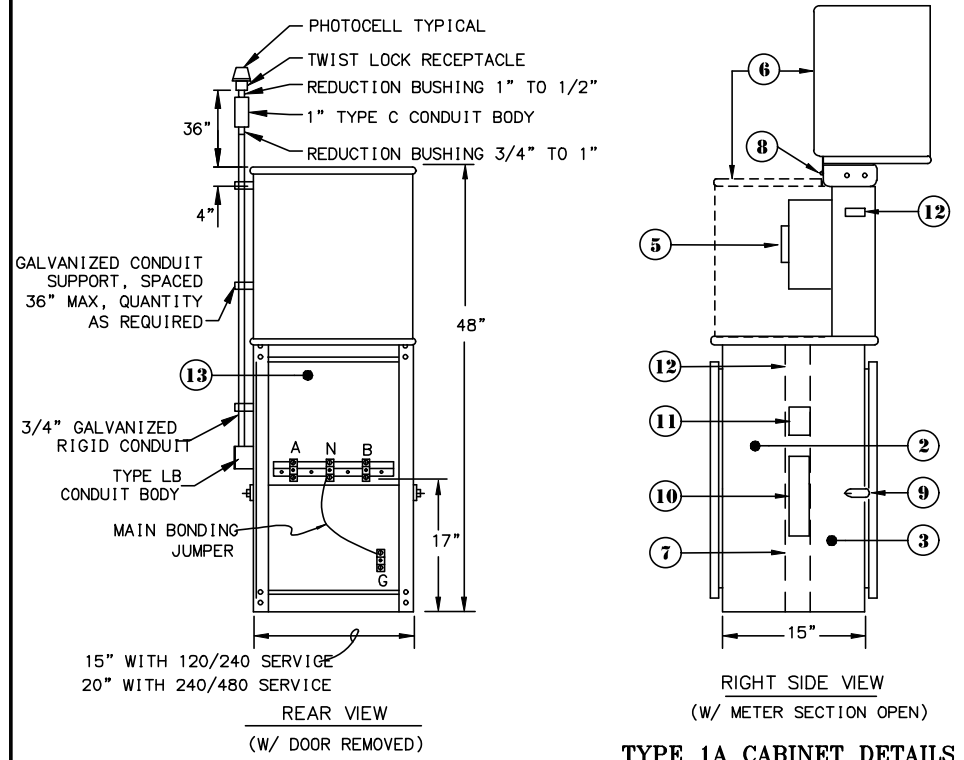

WIRING NOTES:

- FURNISH ALL EQUIPMENT NOTED IN THE LOAD CENTER SUMMARY, IN ADDITION TO TWO(2) 20-AMP, 2-POLE SPARE CIRCUIT BREAKERS, AND A MINIMUM OF TWO(2) SPACES FOR 2-POLE CIRCUIT BREAKERS IN EACH LOAD PANEL. SEE THE LOAD CENTER SUMMARIES FOR ADDITIONAL INFORMATION.
- METER BASES SHALL NOT BE MOUNTED ON MOVABLE PANELS OR DOORS.
- MAIN CIRCUIT BREAKER SHALL BE INDIVIDUALLY MOUNTED ABOVE DISTRIBUTION PANEL BUS.
- LABEL ALL CIRCUIT BREAKERS AS TO FUNCTION AND POSITION. LABEL THE SELECTOR SWITCH "LIGHTING" AND ITS POSITIONS "ON-OFF-AUTO".
- STORE A SCHEMATIC DIAGRAM, A CIRCUIT DIRECTORY, AND A MATERIALS LIST THAT INCLUDES THE MANUFACTURER'S NAME AND PART/CATALOG NUMBERS, ALL LAMINATED IN PLASTIC, IN A METAL POCKET ATTACHED TO THE INSIDE OF THE LOAD CENTER. INSTALL THE POCKET ON THE LOAD CENTER DOOR, PROVIDING DRAIN HOLES TO PREVENT WATER ACCUMULATION.
- INSTALL PHOTOCELL TO AVOID HINGED COVER IN ALL POSITIONS AND ORIENT FACING NORTH SKY AND/OR AWAY FROM ARTIFICIAL LIGHT SOURCES THAT MAY INTERFERE WITH CONTROL. IF PLANS CALL TO MOUNT PHOTOCELL AWAY FROM LOAD CENTER, USE 5C#14 CABLE FROM LOAD CENTER TO PHOTOCELL TWIST LOCK RECEPTACLE.
- SEE DESIGN PLANS AND LOAD CENTER SUMMARIES FOR ADDITIONAL INFORMATION INCLUDING EQUIPMENT LOCATIONS, CONDUIT AND CONDUIT REQUIREMENTS. INSTALL PULL LINE IN SERVICE LATERAL AND CAP BOTH ENDS OF CONDUIT. COORDINATE WITH LOCAL ELECTRICAL UTILITY PROVIDER FOR SERVICE REQUIREMENTS.
- CONDUITS SHALL BE ATTACHED TO LOAD CENTER ENCLOSURE USING A LISTED, GROUNDING TYPE, THREADED CONDUIT HUB.
- PROVIDE ARC-FLASH HAZARD WARNING LABEL COMPLYING WITH NFPA 70E ON THE ENCLOSURE EXTERIOR.
- PROVIDE ENCLOSURE HEATER WHEN INDICATED IN PLANS. INSTALL ENCLOSURE HEATER IN SPACE CONTAINING PANELBOARD BUSSING AND LIGHTING CONTACTORS. HEATER TO BE THERMOSTATICALLY CONTROLLED AND HEAT OUTPUT TO BE SIZED ACCORDING TO COMPARTMENT DIMENSIONS. POWER FROM DEDICATED CIRCUIT AND SIZE CIRCUIT BREAKER TO MANUFACTURER'S RECOMMENDATION.
- WHEN METAL HALIDE OR MERCURY VAPOR LAMPED FIXTURES ARE USED, PROVIDE A REMOTE BULB THERMOSTAT, SO THAT THE CONTACT CLOSURES AND THE LIGHTS TURN ON WHEN THE TEMPERATURE DROPS TO 15° FAHRENHEIT. WIRE THERMOSTAT SO THAT ITS CONTACT IS PARALLEL THE CONTACT IN THE PHOTOELECTRIC CELL.

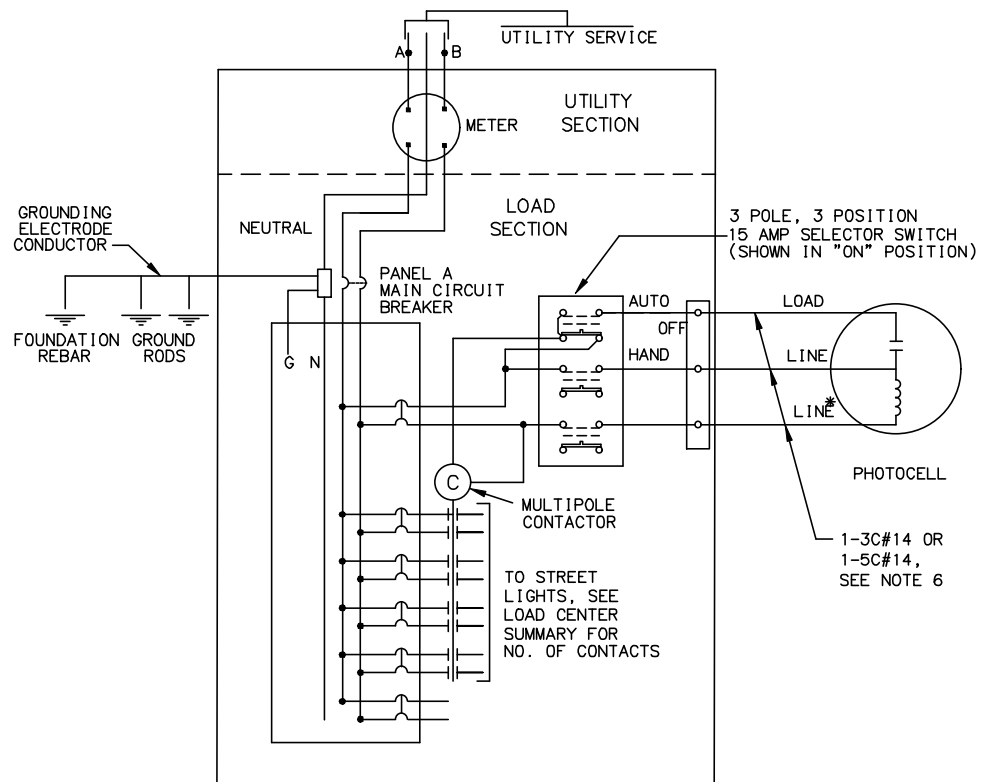

LOAD CENTER ONE LINE DIAGRAM AND SELECTOR SWITCH WIRING

* GROUNDING NEUTRAL, IF SERVICE IS 240/480 VOLT SINGLE PHASE OR 277/480 VOLT THREE-PHASE; AND UNGROUNDING LINE, IF SERVICE IS 120/240 VOLT SINGLE PHASE.

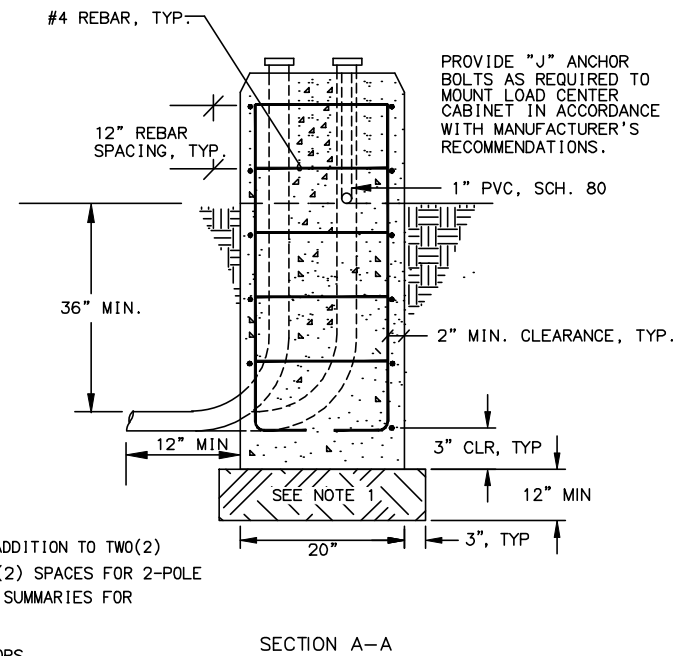
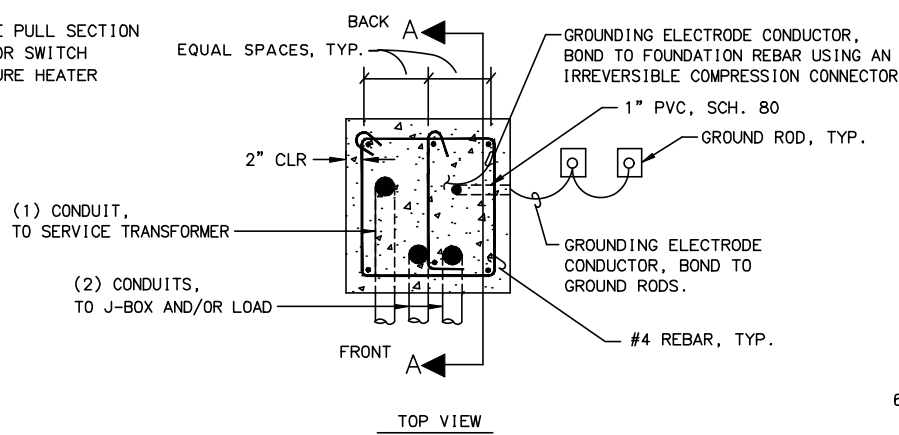

TYPE 1A LOAD CENTER BASE DETAILS

GENERAL NOTES:

- SEE ALASKA DOT&PF STANDARD SPECIFICATIONS FOR HIGHWAY CONSTRUCTION AND STANDARD PLAN DEVELOPMENT REPORT (SPDR) FOR ADDITIONAL REQUIREMENTS.
- CONSTRUCT BASE USING GRADE 60 REINFORCING STEEL CONFORMING TO ASTM A615 AND CLASS A CONCRETE CONFORMING TO SECTION 501 OF THE SPECIFICATIONS.
- IF THE BASE IS PRECAST, INSTALL TWO 3/4" FERRULE LOOP INSERTS IN TWO SIDES OPPOSITE ONE ANOTHER FOR LIFTING.
- ALL BASE REBAR TO BE BONDED TOGETHER TO BE ELECTRICALLY CONTINUOUS.
- PROVIDE ANCHOR BOLTS OR EXPANSION ANCHORS IN THE BASE FOR MOUNTING THE CABINET PER THE MANUFACTURER'S SHOP DRAWINGS. ANCHOR BOLTS, NUTS, AND WASHERS SHALL CONFORM TO EITHER ASTM OR A449 AND SHALL BE GALVANIZED IN ACCORDANCE WITH ASTM A153. A307 CLEARANCE BETWEEN EDGE OF ANCHOR AND BEGINNING OF CHAMFERED EDGE TO BE A MINIMUM OF 2".
- GRADE AWAY FROM THE BASE WITH A MINIMUM SLOPE OF 3%. USE A PRE-MOULDED BITUMINOUS JOINT BETWEEN THE BASE AND CONCRETE SIDEWALK OR PAVING, WHEN ADJACENT TO A SIDEWALK OR PATHWAY.

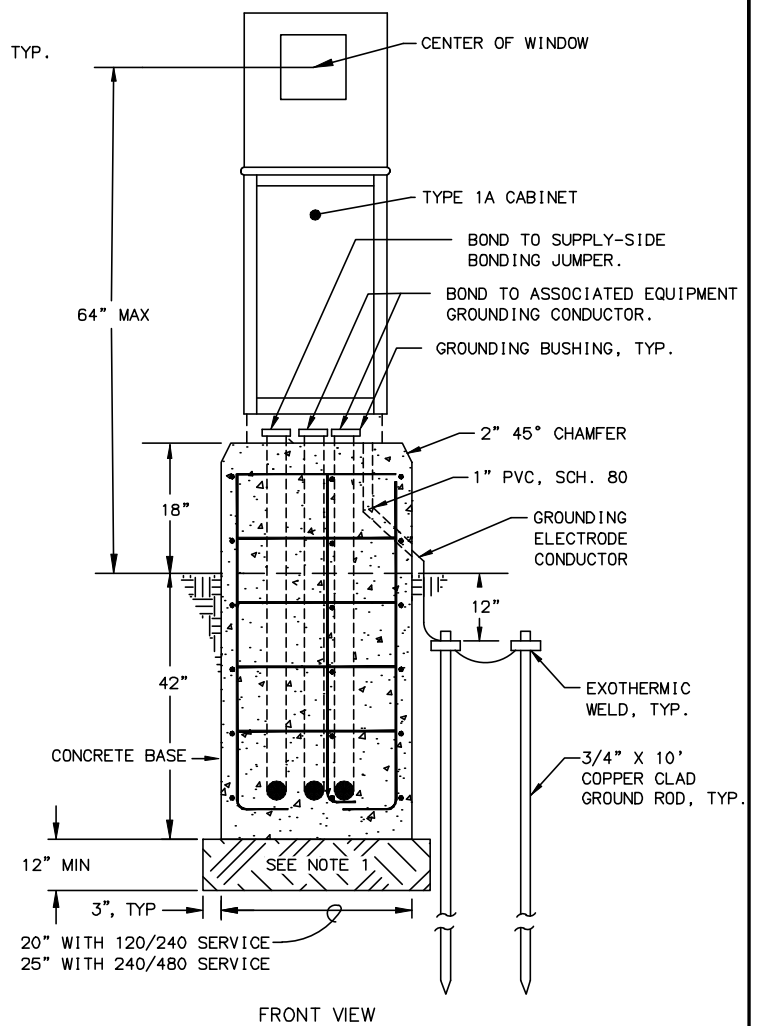

FRONT VIEW

State of Alaska DOT&PF
ALASKA STANDARD PLAN

TYPE 1A LOAD CENTER

Adopted as an Alaska Standard Plan by: *Carolyn Morehouse*
Carolyn Morehouse, P.E.
Chief Engineer

Adoption Date: 7/17/2020

Last Code and Stds. Review By: CNH Date: 7/8/2020

Next Code and Standards Review date: 7/8/2030

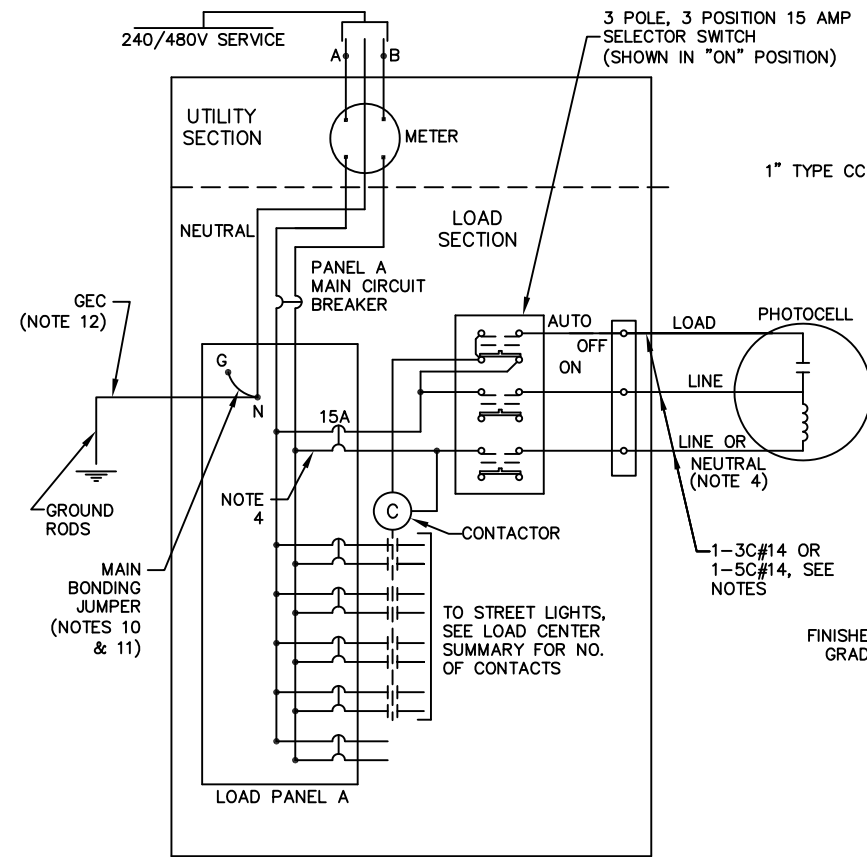

LOAD CENTER ONE LINE DIAGRAM AND SELECTOR SWITCH WIRING

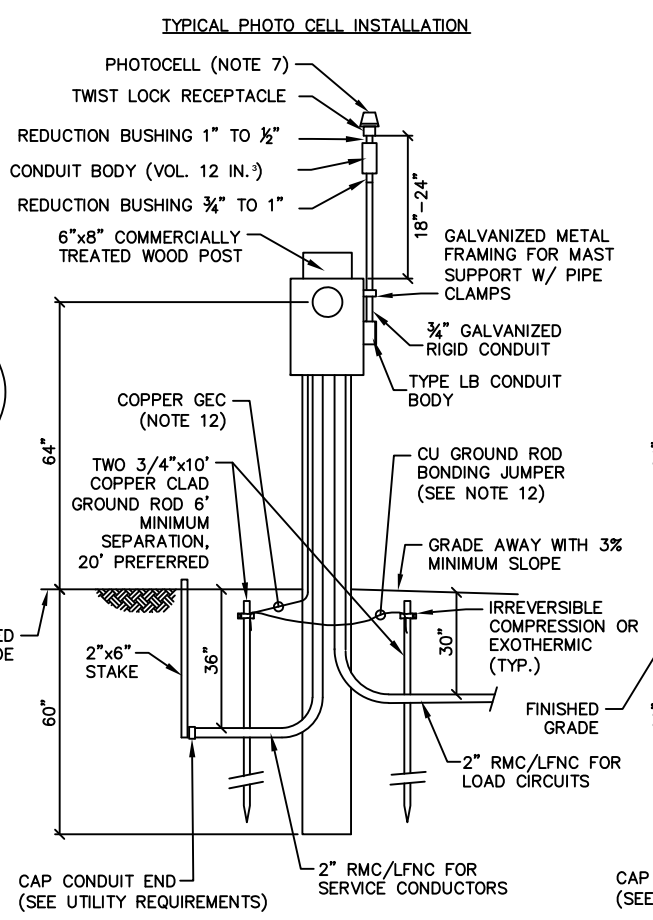

TYPICAL PHOTO CELL INSTALLATION

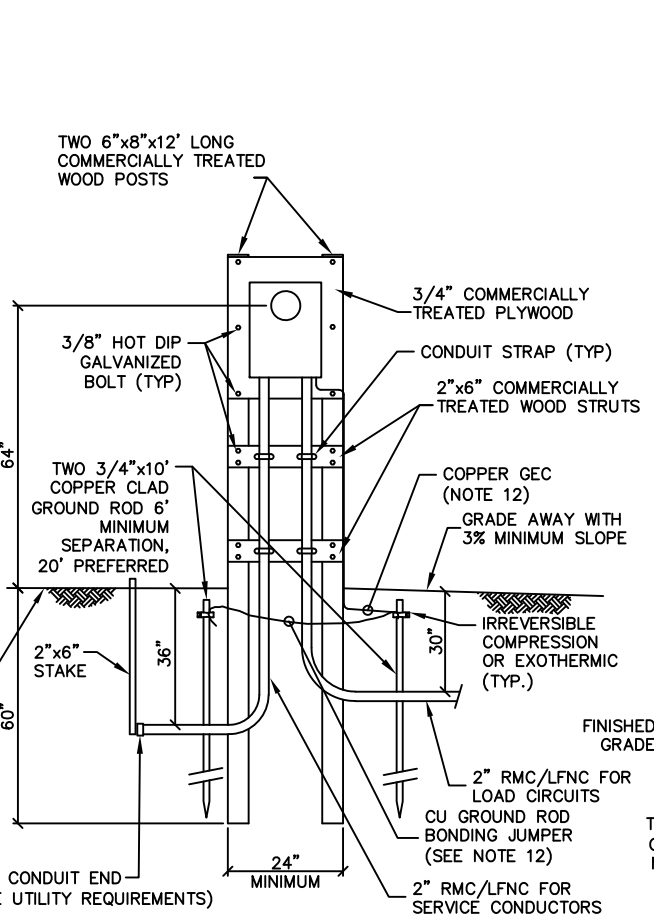

TYPE 2 LOAD CENTER SINGLE POST - STANDARD

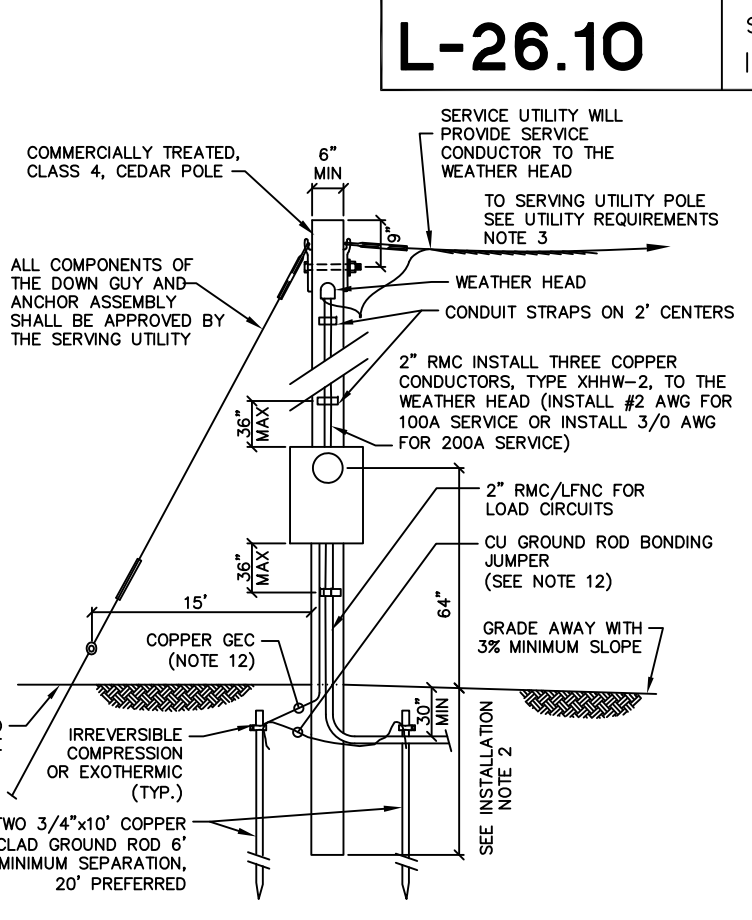

TYPE 2 LOAD CENTER DUAL POST - ALTERNATE

TYPE 3 LOAD CENTER

WIRING NOTES:

- FURNISH ALL EQUIPMENT NOTED IN THE LOAD CENTER SUMMARY, PLUS TWO 20-AMP 2-POLE SPARE CIRCUIT BREAKERS, AND SPACE FOR A MINIMUM OF TWO ADDITIONAL TWO-POLE CIRCUIT BREAKERS, IN EACH LOAD PANEL. SEE SUMMARIES FOR LOAD PANEL VOLTAGES, CURRENT RATINGS, SHORT CIRCUIT INTERRUPTING RATINGS, AND THE NAME OF THE SERVING UTILITY.
- SIZE THE TYPE 2 AND 3 LOAD CENTER CABINETS TO HOLD THE EQUIPMENT SHOWN IN THE WIRING DIAGRAM AND DETAILED IN EACH LOAD CENTER SUMMARY, ALLOWING SPACE FOR WIRING PER THE NATIONAL ELECTRICAL CODE. INSTALLING A METER BASE AND MAIN BREAKER IN A SEPARATE ENCLOSURE IS ALLOWABLE. HOWEVER IN THIS CASE, FURNISH A BREAKER PANEL WITH A MAIN BREAKER.
- LABEL THE SELECTOR SWITCH "LIGHTING" AND ITS POSITIONS "ON-OFF-AUTO".
- THE VOLTAGE FOR THE PHOTOELECTRIC CONTROL EQUIPMENT SHALL BE 240-VOLT, DERIVED FROM THE SERVICE VOLTAGE, OR FROM A CONTROL TRANSFORMER. PROVIDE 1-POLE CIRCUIT BREAKER ON 240/480V LOAD CENTER AND 2-POLE CIRCUIT BREAKER ON 120/240V LOAD CENTERS.
- INSTALL GROUNDING HUBS THIRD PARTY CERTIFIED FOR WET LOCATIONS WHEN ATTACHING CONDUITS TO THE LOAD CENTER ENCLOSURE.
- LABEL ALL CIRCUIT BREAKERS AS TO FUNCTION AND POSITION.
- INSTALL THE PHOTOELECTRIC CONTROL UNIT ON A 3/4" OR LARGER CONDUIT. LOCATE THE UNIT 18"-24" ABOVE THE TOP OF THE LOAD CENTER. ORIENT THE CONTROL WINDOW FACING NORTH AND/OR AWAY FROM ARTIFICIAL LIGHT SOURCES THAT MAY INTERFERE WITH AMBIENT LIGHT CONTROL. INSTALL A 3C#14 CABLE FROM THE LOAD CENTER TO THE TYPE CC CONDUIT BODY WHERE THE SPlice TO THE PHOTOCELL RECEPTACLE CABLE SHALL BE MADE. IF PLANS CALL TO MOUNT PHOTOCELL AWAY FROM LOAD CENTER USE A 5C#14 CABLE FROM LOAD CENTER TO RECEPTACLE. PHOTOCELL MUST BE ENCLOSED IN A METALLIC ENCLOSURE.
- STORE A SCHEMATIC DIAGRAM, A CIRCUIT DIRECTORY, AND A MATERIALS LIST INCLUDING THE MANUFACTURERS' NAMES AND PART/CATALOG NUMBERS, ALL LAMINATED IN PLASTIC, IN A METAL POCKET ATTACHED TO THE INSIDE OF THE LOAD CENTER. INSTALL THE POCKET ON THE LOAD CENTER DOOR, PROVIDING DRAIN HOLES TO PREVENT WATER ACCUMULATION.
- WHEN METAL HALIDE OR MERCURY VAPOR LAMPED FIXTURES ARE USED, PROVIDE A REMOTE BULB THERMOSTAT, SO THAT THE CONTACT CLOSURES AND THE LIGHTS TURN ON WHEN THE TEMPERATURE DROPS TO 15F. WIRE THERMOSTAT SO THAT ITS CONTACT IS PARALLEL THE CONTACT IN THE PHOTOELECTRIC CELL.
- INSTALL #6 AWG COPPER MAIN BONDING JUMPER, OR SIZE PER NEC TABLE 250.102 (C)(1), WHICHEVER IS LARGER.
- INSTALLATION MUST COMPLY WITH NEC 250.24(C) AND 250.24 (C) EXCEPTION WHEN MORE THAN ONE PANELBOARD IS PRESENT.
- INSTALL #6 AWG COPPER GROUNDING ELECTRODE CONDUCTOR (GEC), OR SIZE PER NEC TABLE 250.66, WHICHEVER IS LARGER. USE THE SAME METHOD TO SIZE GROUND ROD BONDING JUMPER.
- MAXIMUM METER HEIGHT SHALL NOT EXCEED 64" FROM FINISHED GRADE TO CENTER OF THE METER SOCKET COVER.
- WHEN SHOWN ON THE PLANS, INSTALL ENCLOSURE HEATER WITH INTEGRAL THERMOSTAT, SET TO ENERGIZE THE HEATER AT TEMPERATURES AT OR BELOW 32-DEG F. SCHNEIDER ELECTRIC CAT. NO. NSYCRP1W230VTV, NVENT-HOFFMAN CAT. NO. DAH4002B, OR APPROVED EQUAL.
- BOND SERVICE CONDUIT GROUNDING BUSHING TO SUPPLY-SIDE BONDING JUMPER. BOND LOAD CONDUIT GROUNDING BUSHINGS TO ASSOCIATED EQUIPMENT GROUNDING CONDUCTORS (EGC'S).

INSTALLATION NOTES:

- INSTALL TYPE 3 LOAD CENTER POLES OF SUFFICIENT LENGTH TO PROVIDE THE FOLLOWING MINIMUM GROUND TO SERVICE CONDUCTOR CLEARANCE:
 - 18.5 FEET, IF THE SERVICE CONDUCTORS ARE LOCATED ABOVE ROADWAYS OR PARKING AREAS.
 - 26.5 FEET, IF THE SERVICE CONDUCTORS ARE LOCATED WITHIN 20 FEET OF A RAILROAD TRACK.
 - 18.5 FEET IN ALL OTHER CIRCUMSTANCES.
- SET THE BUTT END OF TYPE 3 LOAD CENTER POLES TO THE FOLLOWING MINIMUM DEPTH:
 - 10 PERCENT OF ITS LENGTH PLUS 24 INCHES, OR 60 INCHES, WHICHEVER IS GREATER, IF IT IS INSTALLED IN EARTH OTHER THAN SOLID ROCK OR MUSKEG.
 - 10 PERCENT OF ITS LENGTH, OR 48 INCHES, WHICHEVER IS GREATER, IF IT IS INSTALLED IN SOLID ROCK.
 - CONSIDER MUSKEG TO BE AIR, AND SET THE BUTT ENDS TO THE DEPTH GIVEN IN A OR B, WHICHEVER APPLIES, IN THE UNDERLYING EARTH OR ROCK.
- WHENEVER MORE THAN 24 INCHES OF EARTH OVERLAYS ROCK, OR THE DIAMETER OF THE DRILLED HOLE IN ROCK EXCEEDS TWICE THE DIAMETER OF THE POLE AT THE GROUND LINE, CONSIDER THE INSTALLATION AS EARTH.
- ATTACH ALL CONDUITS TO THE POSTS AND POLES USING TWO HOLE RIGID METAL CONDUIT STRAPS LOCATED ON 24 INCHES MAXIMUM CENTERS.
- ATTACH ALL GROUND CONDUCTORS TO THE POSTS AND POLES USING CABLE STAPLES LOCATED ON 12 INCH CENTERS. MAKE ALL GROUNDING CONDUCTORS CONTINUOUS. USE #6 AWG CU GEC FOR 100A SERVICE AND #4 AWG CU GEC FOR 200 AMP SERVICE.
- ALL POSTS, POLES, AND STRUTS SHALL BE COMMERCIALY TREATED AND SHALL MEET THE REQUIREMENTS SET FORTH IN ALASKA DOT&PF SSHC SECTIONS 713 & 714.
- ALL ELECTRICAL ENCLOSURES SHALL FEATURE MEANS FOR SEALING AND LOCKING ALL DOORS AND ACCESS COVERS THAT MAY CONTAIN EXPOSED ENERGIZED ELECTRICAL PARTS.

UTILITY REQUIREMENTS:

- USE THE SINGLE-POST TYPE 2 "STANDARD" LOAD CENTER IN ALL LOCATIONS EXCEPT WHERE THE SERVING UTILITY REQUIRES THE TWO-POST TYPE 2 "ALTERNATIVE" LOAD CENTER. REFER TO THE LOAD CENTER SUMMARY FOR WHICH TO INSTALL.
- THE LENGTH AND TYPE OF SERVICE ENTRANCE CONDUIT INSTALLED BY THE CONTRACTOR VARIES BY UTILITY. REGARDLESS OF ITS LENGTH, INSTALL A PULL ROPE IN THE SERVICE CONDUIT AND A CAP ON THE BURIED END. MARK THE BURIED END WITH A 2"x6" WOOD STAKE. SEE THE LOAD CENTER SUMMARIES FOR THE FOLLOWING INFORMATION:
 - STATION AND OFFSET OF THE LOAD CENTER AND POWER SOURCE.
 - WHERE THE CONTRACTOR TERMINATES THE SERVICE ENTRANCE CONDUIT.
 - THE TYPE OF SERVICE ENTRANCE CONDUIT (SUCH AS RIGID METAL CONDUIT OR LIQUID-TIGHT FLEXIBLE METAL CONDUIT).
 - THE MAXIMUM AND MINIMUM DISTANCES ALLOWED BETWEEN THE TYPE-3 LOAD CENTER POLE AND UTILITY POLE TO WHICH THE AERIAL DROP IS CONNECTED.
- VERTICAL CLEARANCE FOR SERVICE-DROP CONDUCTORS IN ACCORDANCE WITH NEC 230.24(B).

State of Alaska DOT&PF
ALASKA STANDARD PLAN

TYPE 2 AND 3
LOAD CENTERS

Adopted as an Alaska Standard Plan by: *Carolyn Morehouse*
Carolyn Morehouse, P.E.
Chief Engineer

Adoption Date: 07/17/2020

Last Code and Stds. Review
By: JC Date: 07/17/2020

Next Code and Standards Review date: 07/17/2030

MATERIAL REQUIREMENTS		
Concrete	Class A	$f'_c = 4000$ PSI
CMP	AASHTO M218	14 GA.
VERTICAL REINFORCING STEEL	AASHTO M31 #8	GR 60
SPIRAL REINFORCING STEEL	AASHTO M31 #5	GR 60
GROUND WIRE		#4 AWG
Frangible Coupling and Anchor	NCHRP 350 TL3 (See note 10)	$V_u = 5.5$ KIPS
Conduit	Sch 40	RMC
Protective Sleeve	Sch 40	PVC

DEPTH TABLE (See design notes for loads)	
GRADE	FOUNDATION DEPTH (ft.)
FLAT TO 6:1	8
$\geq 6:1$ TO 3:1	9
$\geq 3:1$ TO 1.5:1	10.5

CONTROLLED LOW STRENGTH MATERIAL MIX DESIGN		
ITEM	BATCHING QUANTITIES PER CYD BATCH (LBS.)	APPLICABLE SPECS.
PORTLAND CEMENT CONCRETE	188	701-2.01
Water (52.1 Gal.)	435	712-2.01
Fine Aggregate SSD	3041	703-2.01
Admixture: Air entrainment	2.0 OZ.	711-2.02
Total	3664	

DESIGN NOTES:

Design Standard: 2013 Standard Specifications for Structural Supports for Highway Signs, Luminaires and Traffic Signals with 2019 and 2020 Interim Revisions (SSSS).

Maximum Unfactored Service Loads (SSSS): 1,500 lbs axial, 1,500 lbs shear, 35,000 ft-lbs moment.

Wind and Soil: Foundations shall not be used for locations over 100 mph basic wind speed as shown in the SSSS figure 3.8.3-1. This foundation is approved for electrolier and breakaway traffic signal applications in cohesionless soils with an NI-60 value of 20 or greater (SPT) and a minimum soil density = 120pcf and friction angle of 32.5 degrees per AASHTO T-206, "Standard Penetration Test" (SPT).

NOTES:

- This foundation shall not be used if any of the following are encountered; water table above the bottom of foundation, very loose soils, organic soils, cohesive soils (clay), or soils susceptible to frost jacking. If any of these conditions are encountered, stop foundation work and contact the Engineer.
- Place foundation in drilled or excavated hole with centerline of foundation located at the station, offset, and elevation specified in plans. Set foundation to satisfy the conditions depicted in clearance detail.
- Form the foundation in corrugated metal pipe conforming to Subsection 707-2.01 of the Specifications.
- Provide 1.5 extra turns at each end of the spiral reinforcing steel. Reinforcing steel shall not be spliced. Tie vertical reinforcing steel to each intersection of the spiral reinforcing steel.
- Connect ground wire near the top of spiral reinforcing steel with two irreversible connectors as shown. Fasten connectors according to the manufacturers' recommendations including the use of manufacturer specified tools. The ground wire may be bare solid, stranded, or braided copper. Protect ground wire with protective sleeve as shown and fill with silicon sealant.
- Backfill and compact according to Section 205, and Subsections 203-3.04 and 660-3.01 of the Specifications. Use selected material, Type A or controlled low strength material as backfill material. Ensure area below foundation meets compaction requirements and is free of loose material and debris prior to concrete work.
- Install all anchors according to the manufacturer's written installation instructions. Anchors shall be installed plumb. Anchors greater than 1:40 out-of-plumb will result in foundation rejection.
- Grade in depth table refers to fill slopes. If foundation is in a cut slope assume flat grade in table. To determine grade in fill slopes, use the most severe grade found within an 8 foot radius of the center of the foundation.
- If provided couplings have greater design values than $V_u=5.5$ kips per each coupling (22,000 lbs total), submit stamped engineering calculations, related drawings, and other necessary information as required to verify the adequacy of the foundation design for increased loads.
- Frangible couplings shall be NCHRP 350, Test Level 3 compliant and installed in accordance with the manufacturers written instructions.
- Frangible couplings shall be installed into flush mounted female anchors so that no fixed hardware extends above the foundation top.
- Install all components of the breakaway support system in accordance with the manufacturer's written instructions.
- Fabricate the skirt as shown in detail. Bend each plate to provide corners with a 3/4" radius. The assembled skirt measures about 12-7/8" square.

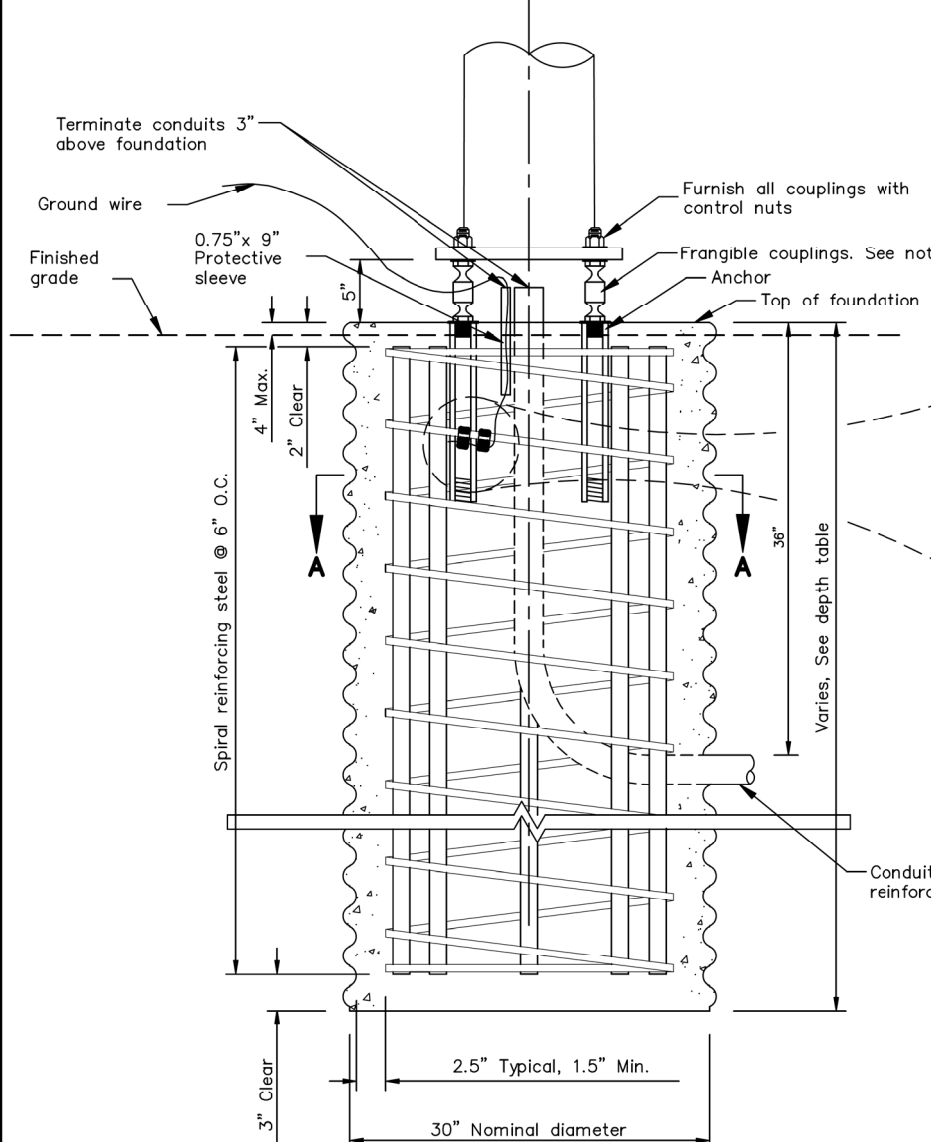
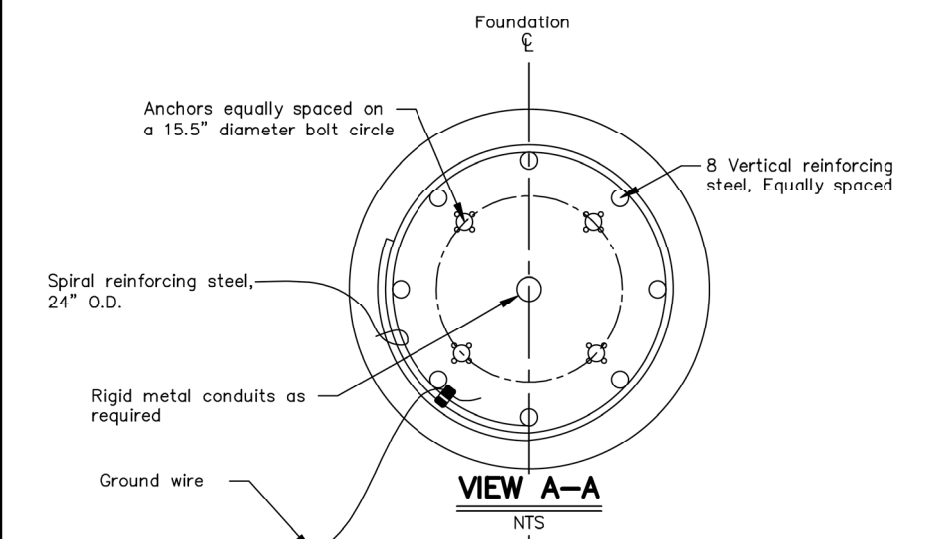

FOUNDATION DETAILS

Skirt omitted for clarity

Base plate see L-03.12

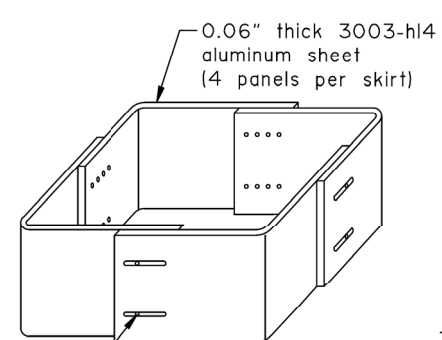
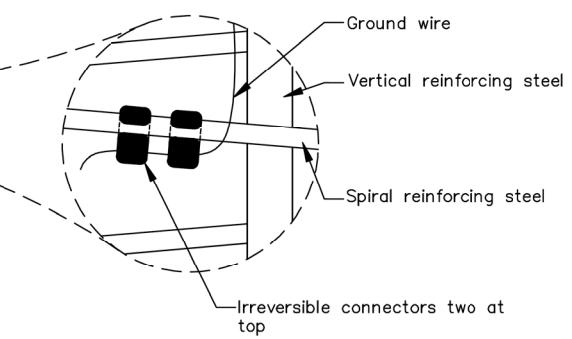

SKIRT DETAIL

Assemble skirt with eight No. 10 x 3/8" stainless steel sheet metal screws or pop rivets, each panel overlap location.

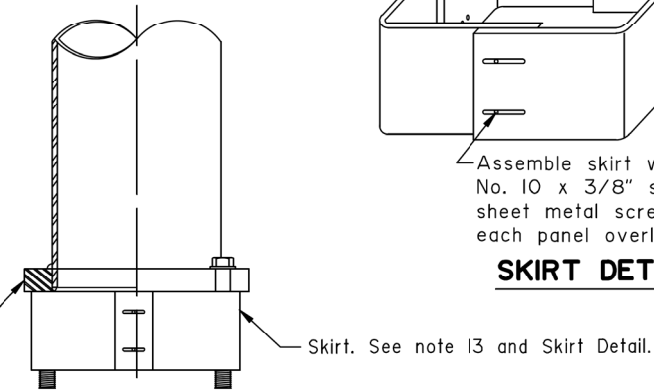

BASE PLATE

Skirt. See note 13 and Skirt Detail.

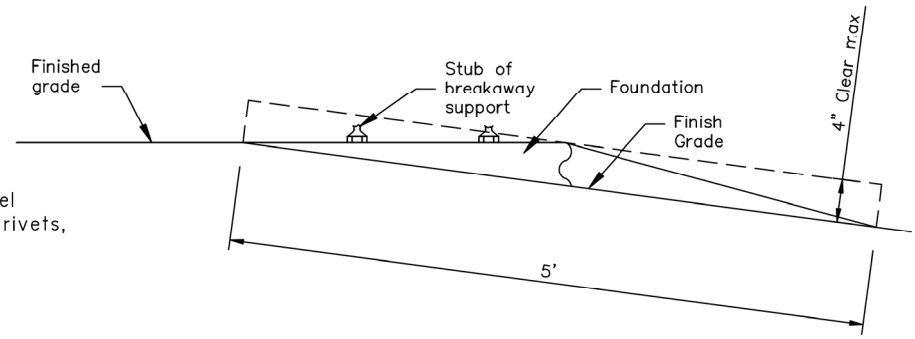

CLEARANCE DETAIL

State of Alaska DOT&PF
ALASKA STANDARD PLAN
CONCRETE STREET LIGHT
POLE FOUNDATION

Adopted as an Alaska Standard Plan by:
Lauren Little, P.E.
Interim Chief Engineer

Adoption Date: 01/29/2024

Last Code and Stds. Review
By: AH Date: 12/13/2023

Next Code and Standards Review Date: 12/13/2033

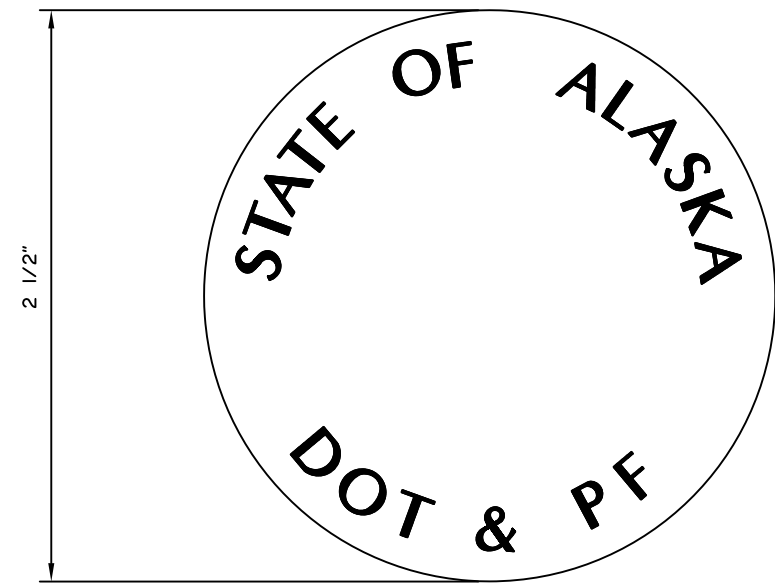

GENERAL NOTES:

1. For Structures under 200' total length: provide 1 monument.
2. For Structures 200' or over: provide 2 Monuments.
3. Monuments shall be located as directed by the Engineer.

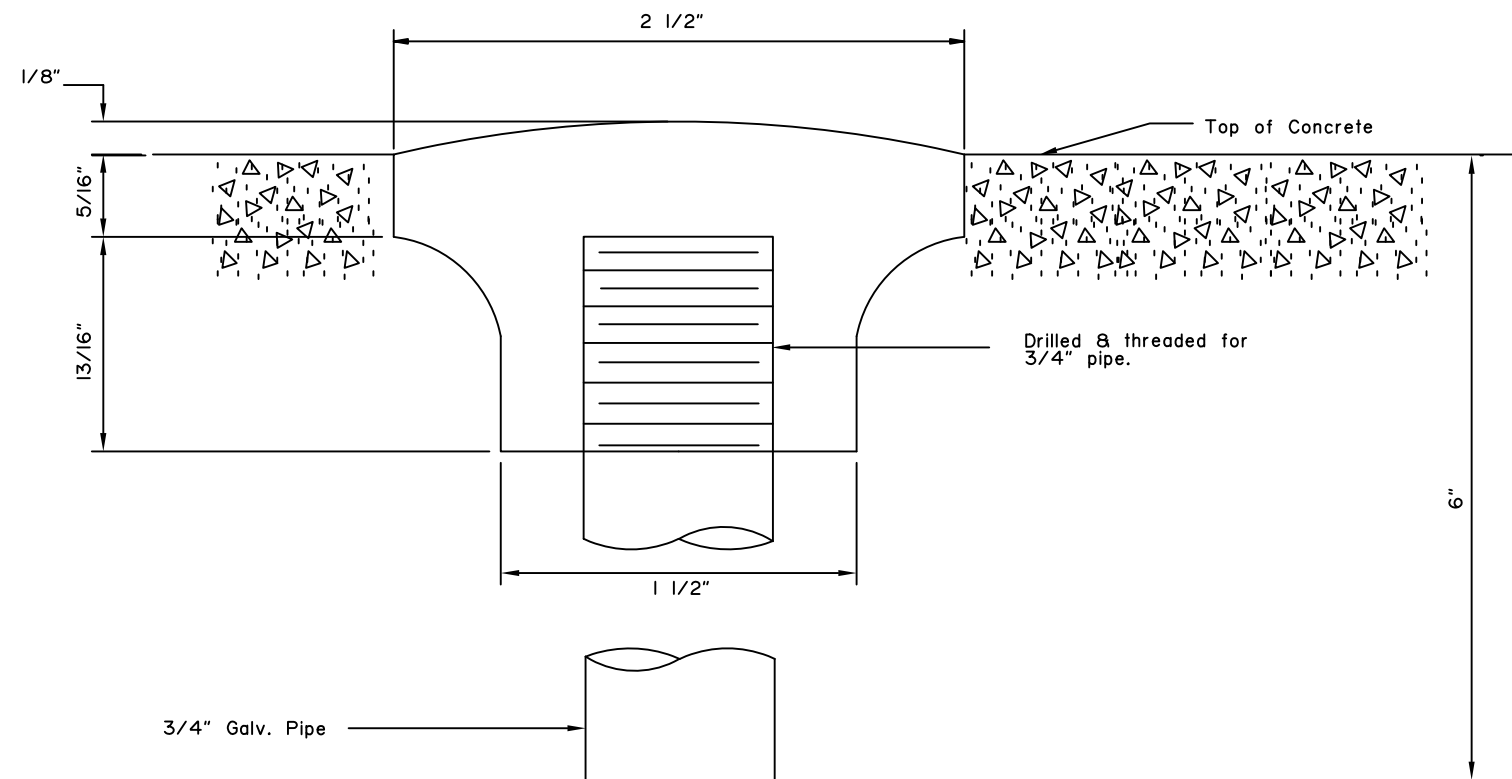

SURVEY MONUMENT

State of Alaska DOT&PF
ALASKA STANDARD PLAN

SURVEY MONUMENT

Adopted as an Alaska
Standard Plan by: *Kenneth J. Fisher*
Kenneth J. Fisher, P.E.
Chief Engineer

Adoption Date: 02/08/2019

Last Code and Stds. Review
By: Date:

Next Code and Standards Review date: 02/08/2029

GENERAL NOTES:

1. Details shown are to indicate general design only. Dimensions and design may vary among the manufacturers.
2. Where monument cases are to be placed in paved area of a roadway or sidewalk, the top of the case and/or cover shall be the same elevation as the top of the finish surface with bolting type access cover.
3. Where monument cases are to be placed in a gravel surfaced roadway, the top of the case shall be placed 1'-0" below the top of the surface of the roadway.
4. In solid rock, drill a 2" Dia. hole a minimum of 1'-0" deep, fill with mortar and set cap. 3/4"x9" galvanized pipe, designated length when set in mortar.
5. The top of the monument cap shall be placed 1' above the bottom of the monument case.

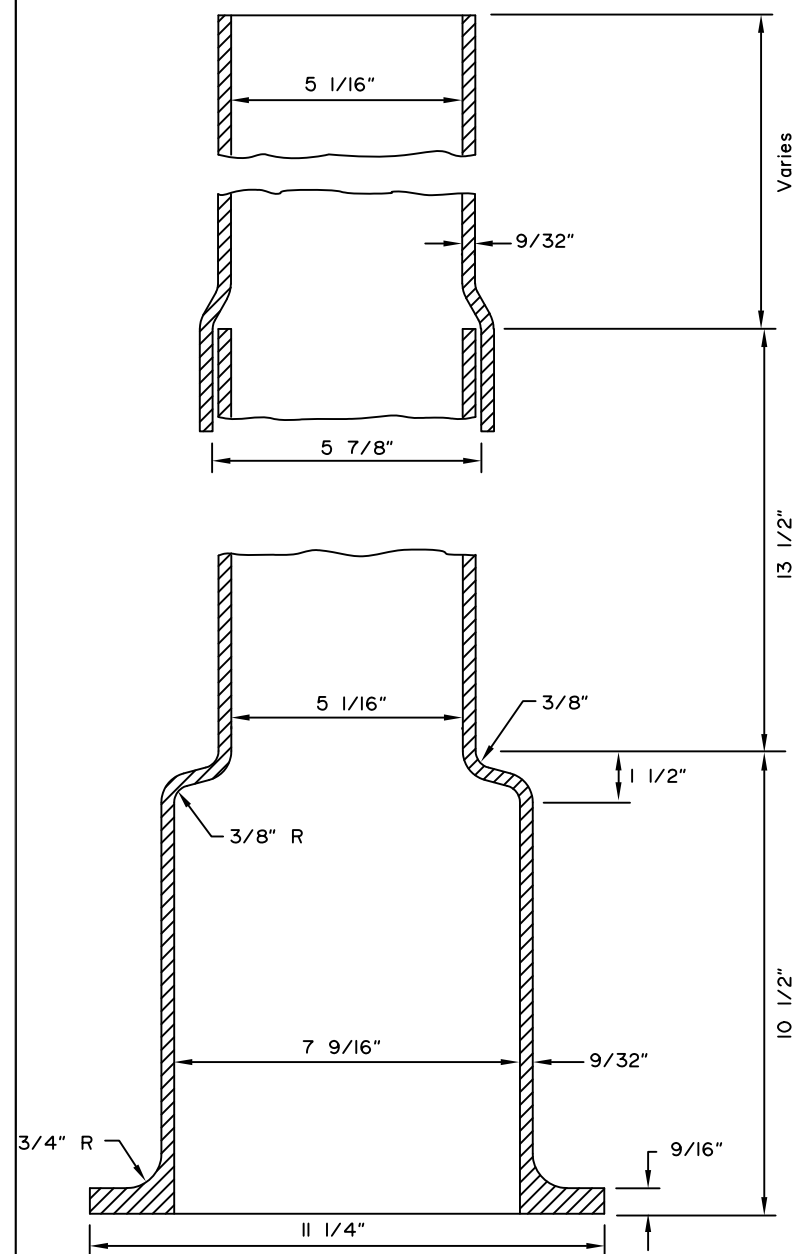

EXTENSION PIPES

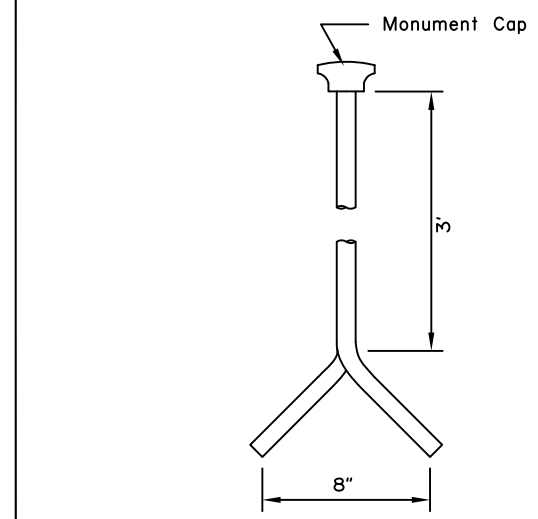

MONUMENT DETAIL

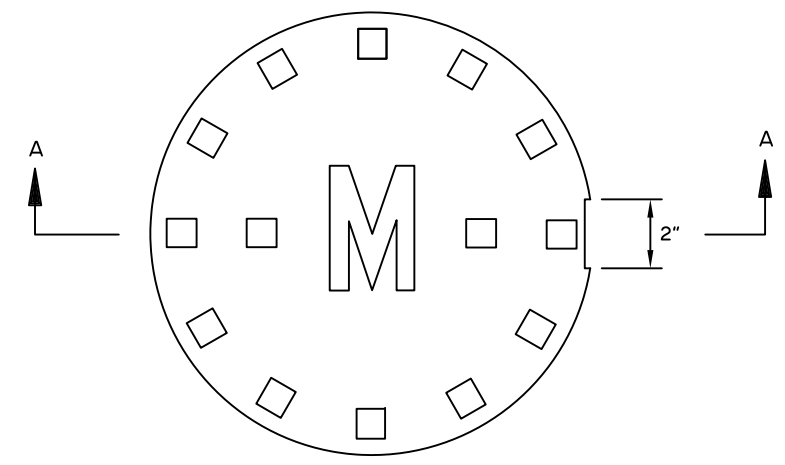

PLAN VIEW ACCESS COVER

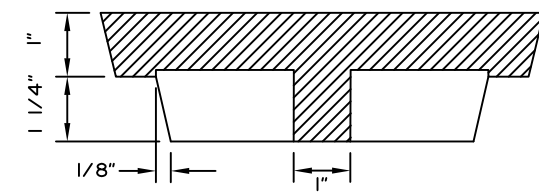

SECTION A-A

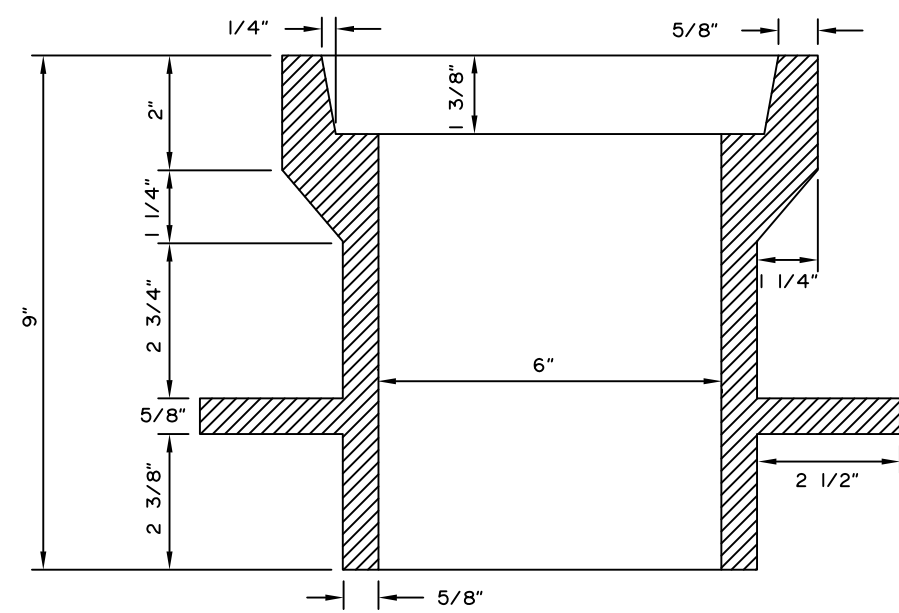

MONUMENT CASE

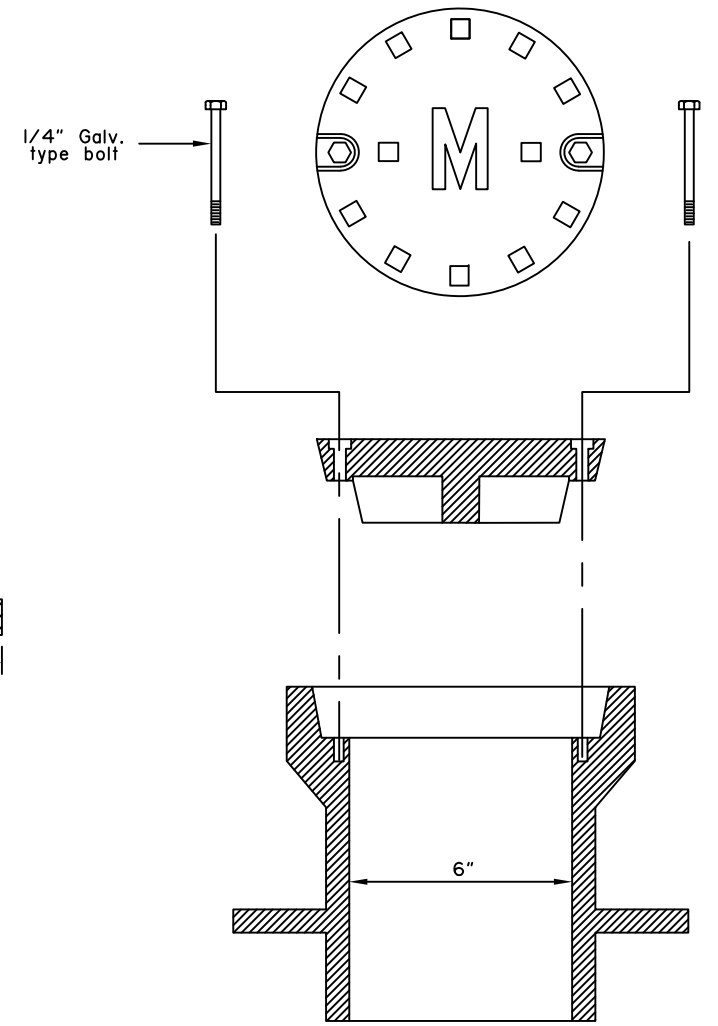

BOLTING MONUMENT CASE ASSEMBLY
(See Note 2)

State of Alaska DOT&PF
ALASKA STANDARD PLAN
BRASS CAP MONUMENT
AND MONUMENT CASE

Adopted as an Alaska
Standard Plan by: *Kenneth J. Fisher*
Kenneth J. Fisher, P.E.
Chief Engineer

Adoption Date: 02/08/2019

Last Code and Stds. Review
By: Date:
Next Code and Standards Review date: 02/08/2029

V_c = Average Daily Traffic on Cross Road (vehicles per day)
 V_m = Average Daily Traffic on Main Road (vehicles per day)
 n = Number of Mailboxes at Mail Stop

Posted Main Road Speed Limit	"D1" Distance (ft)	
	$n \times V_c \times V_m$	
≤ 40	65	200
> 40	65	295

Posted Main Road Speed Limit	"D2" Distance (ft)	
	Cross Road ADT	
≤ 40	100	100
> 40	150	200

"D3" Distance (ft)	
Preferred	Minimum
100	65

"D4" Distance (ft)	
Preferred	Minimum
150	100

	Desirable	Minimum
MPH	C_1	C_2^*
≤ 40	15'	25'
> 40	20'	50'

* Mailboxes should be placed on the far side of driveway entrance unless the design value $D1$ cannot be met.

GENERAL NOTES:

1. Install mailboxes conforming to U.S. Postal Service requirements.
2. Mailbox supports shall not present a rigid, unyielding impact resistant hazard to road traffic, but shall be flexible and yielding to vehicular impact. Install crashworthy supports in accordance with Standard Plan M-23.
3. Installation shall be on the right side of roadway in the direction of mail carrier travel with the exception of one-way streets where they may be placed on either side.
4. Locate mailboxes to minimize dangers to road traffic, carriers and postal recipients.
5. Provide a minimum shoulder width of 8' unless otherwise approved by Engineer. Install single and double mailbox supports separated by at least 3', and desirably 4', from each other. More than two boxes on a single support is allowable only as shown on Standard Plan M-23.
6. Newspaper receptacles shall conform to the same setback and support regulations as mailboxes. Where newspaper receptacles and mailboxes are to be mounted together, the newspaper receptacle may be mounted beneath the mailbox or on the side of the mailbox support opposite the reflecting marker.

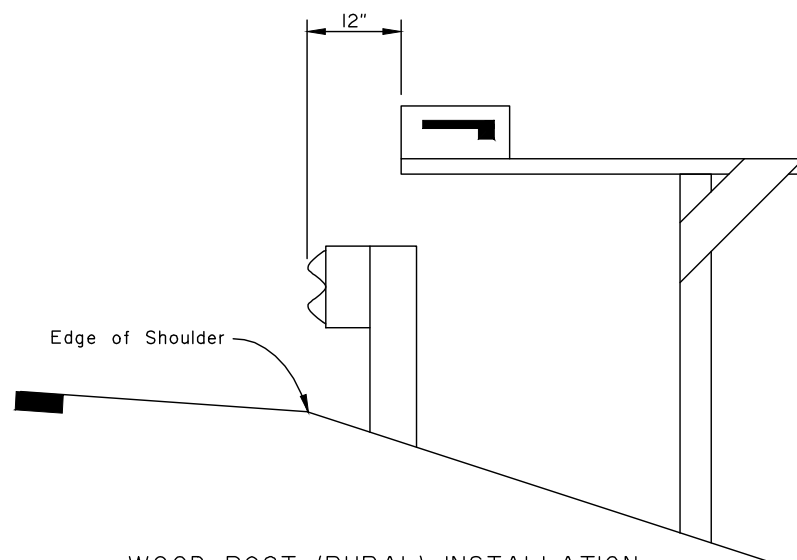
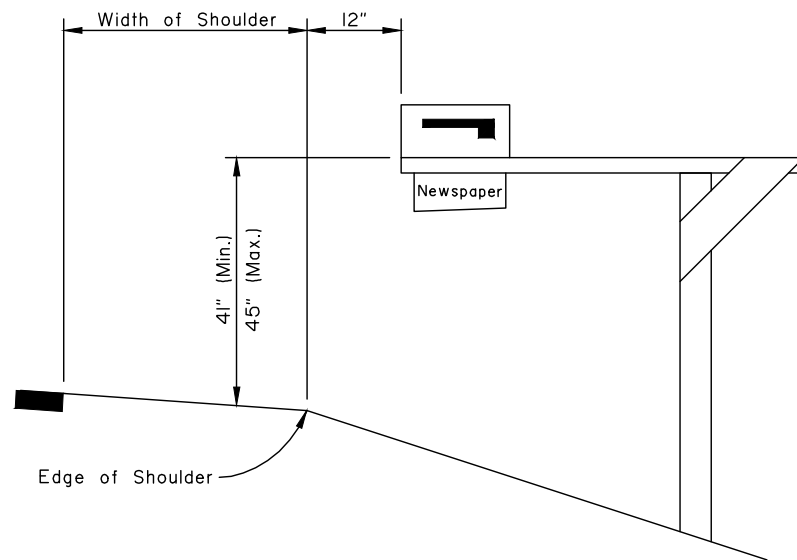

WOOD POST (RURAL) INSTALLATION

Single or Double Box

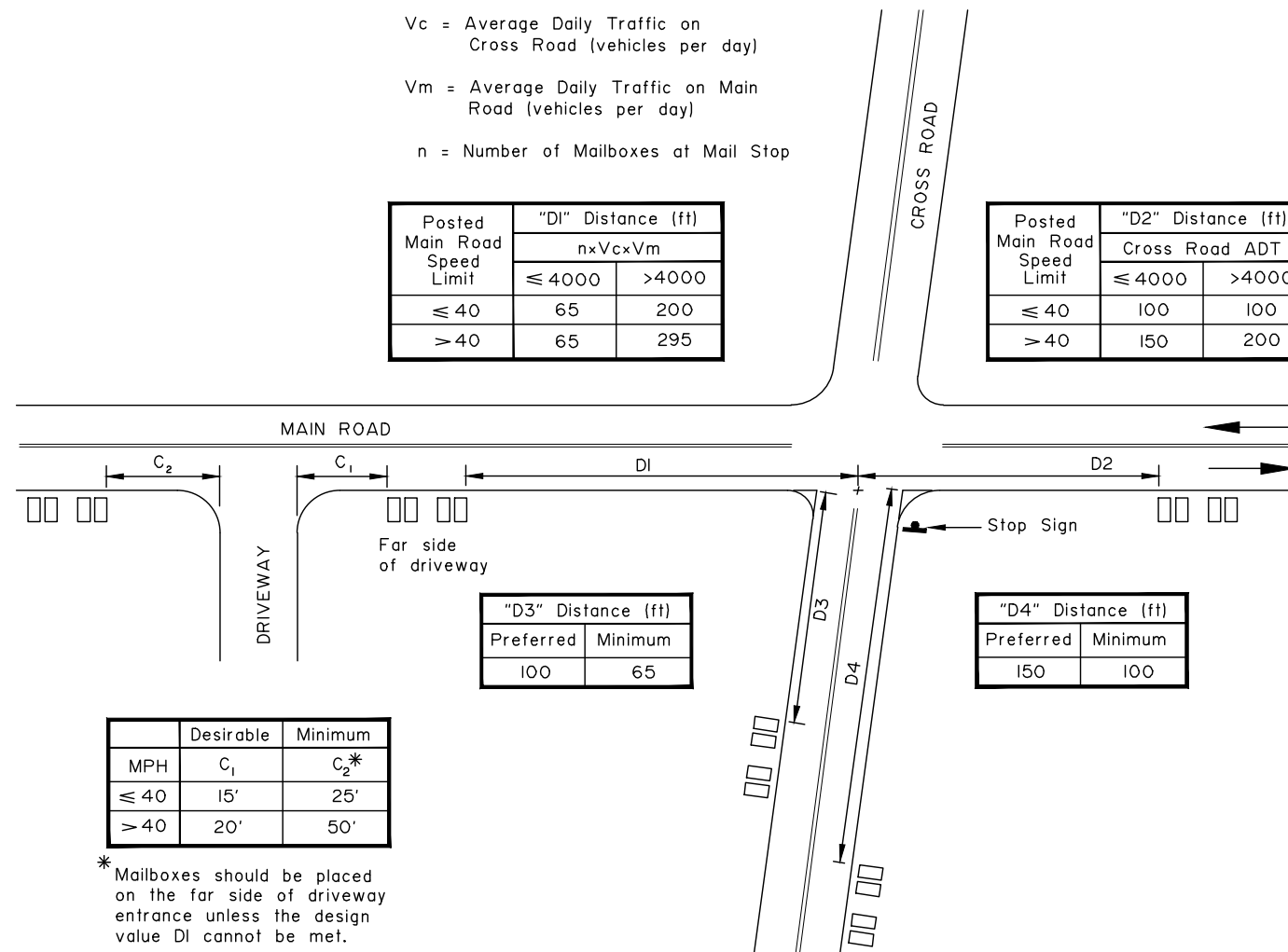

MAILBOX LOCATION AT INTERSECTIONS AND DRIVEWAYS

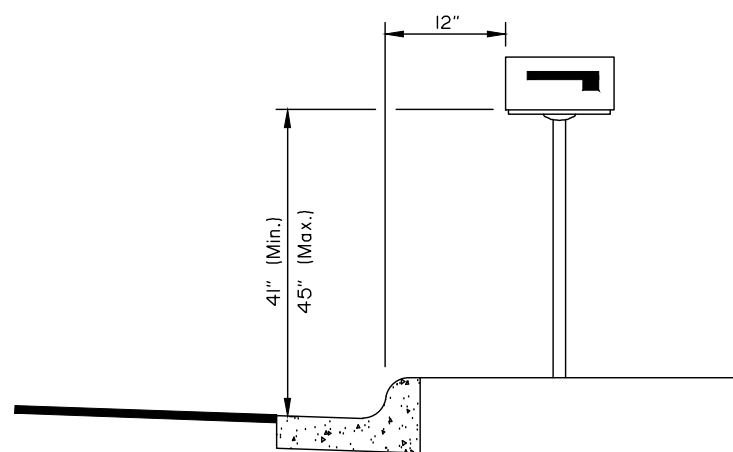

METAL POST (URBAN) INSTALLATION

Single or Double Box

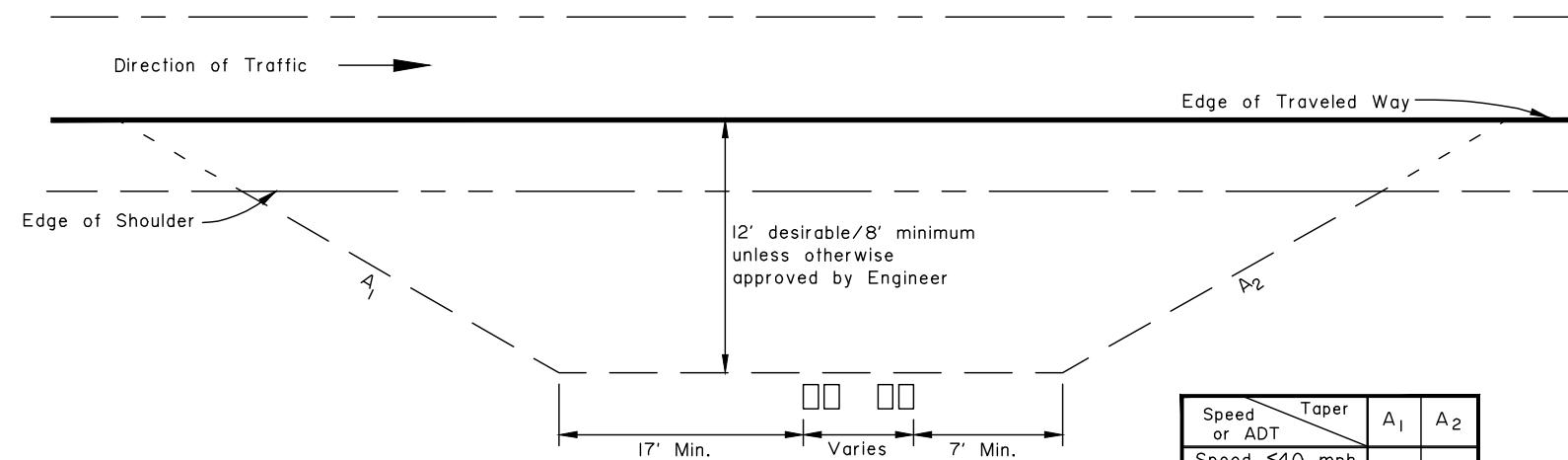

TURNOUTS FOR GROUPED BOXES

Speed or ADT	Taper	A ₁	A ₂
Speed ≤ 40 mph and ADT ≤ 400		4:1	2.5:1
Speed > 40 mph or ADT > 400		20:1	12:1

TURNOUT TAPERS

State of Alaska DOT&PF
ALASKA STANDARD PLAN

MAILBOX LOCATION

Adopted as an Alaska Standard Plan by: *Carolyn Morehouse*
Carolyn Morehouse, P.E.
Chief Engineer

Adoption Date: 7/17/2020

Last Code and Stds. Review
By: KLH Date: 7/8/2020

Next Code and Standards Review date: 7/8/2030

GENERAL NOTES:

1. See Standard Plan M-20 for locating posts and boxes along roadway.
2. Posts shall be 6"x6" Treated Wood Post S4S or 2" (Max.) Standard Weight Steel Pipe.
3. Each support structure shall not accommodate more than two mailboxes unless the support structure conforms to the requirements of the U.S. Postal Service and is approved by the Engineer.
4. Other steel or aluminum structural sections may be used except, the stiffness properties equivalent to the 2" dia. standard weight steel pipe shall not be exceeded.
5. Reflectors shall have a minimum area of 4.5 sq. in.

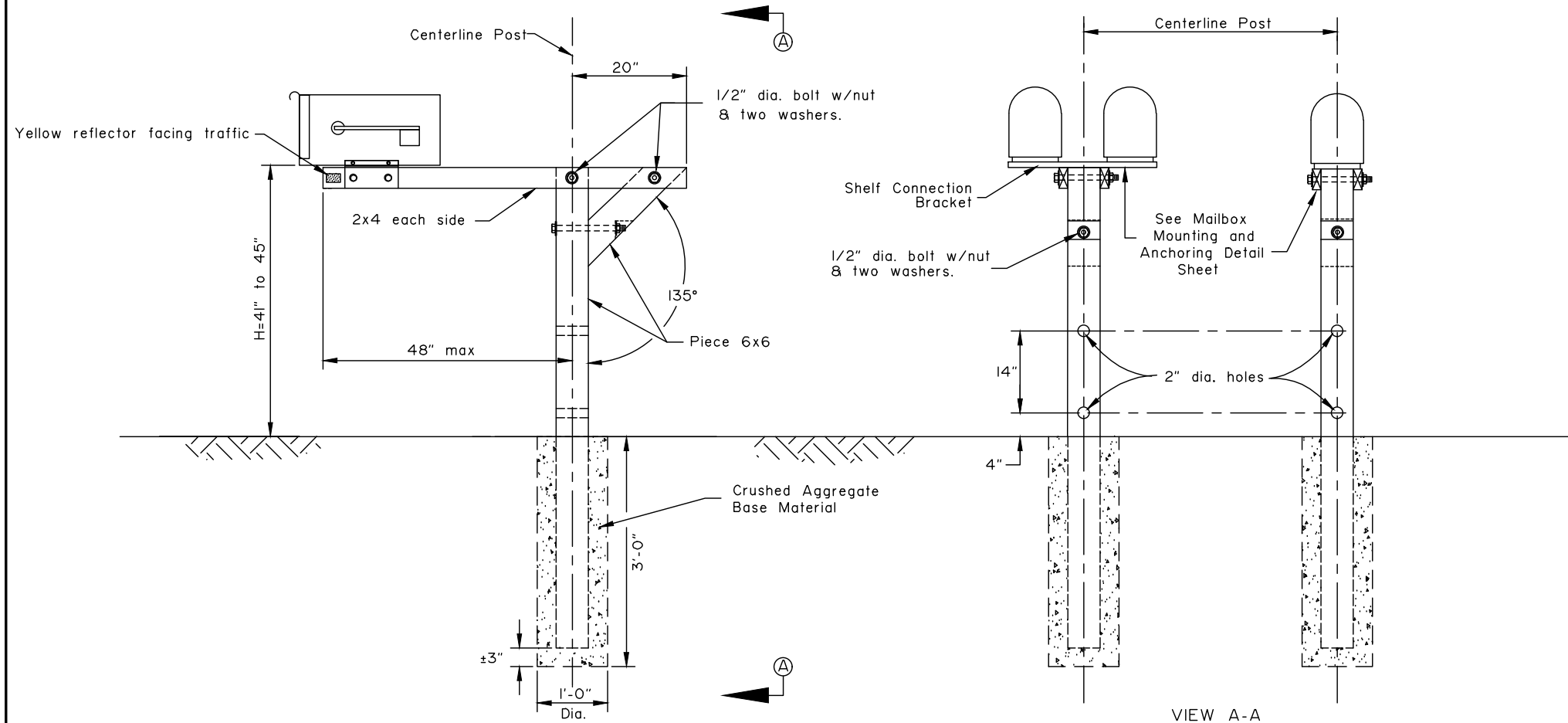

TYPICAL WOOD CANTILEVER INSTALLATION

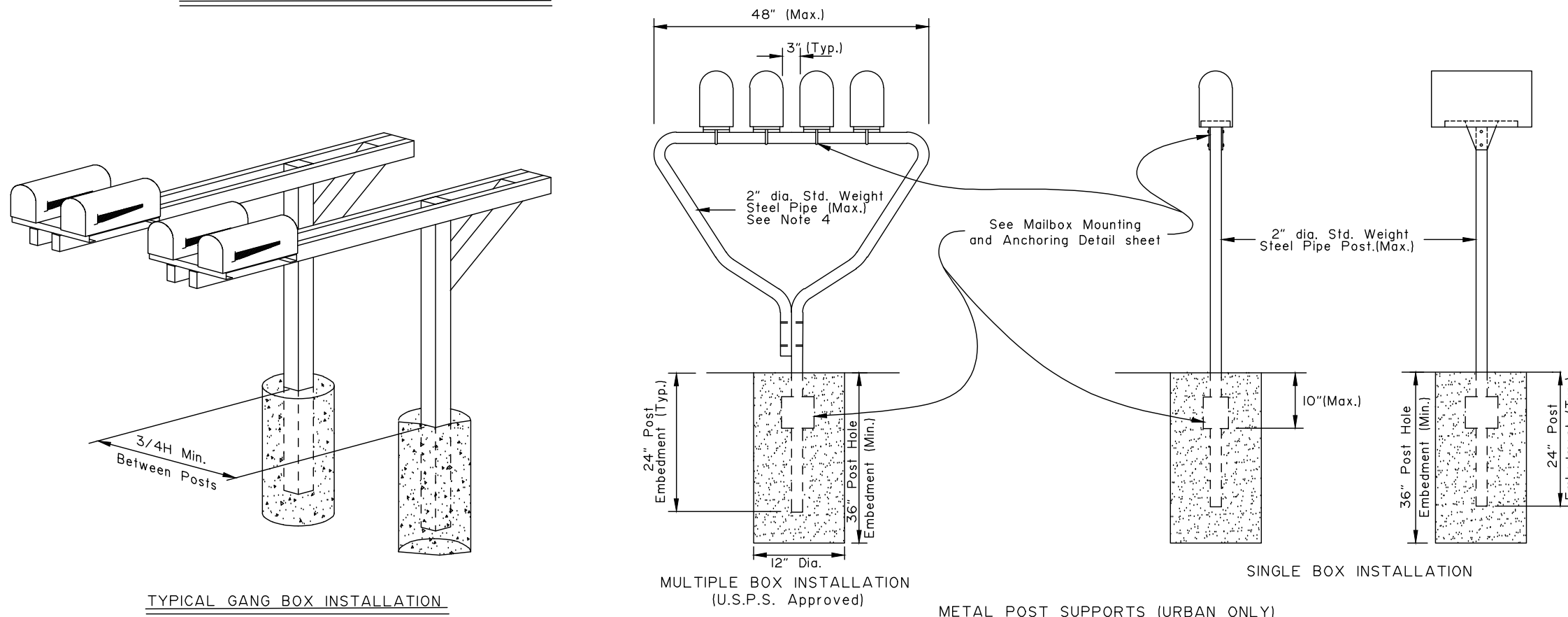

TYPICAL GANG BOX INSTALLATION

METAL POST SUPPORTS (URBAN ONLY)

State of Alaska DOT&PF
ALASKA STANDARD PLAN

MAILBOX
INSTALLATION

Adopted as an Alaska Standard Plan by: *Carolyn Morehouse*
Carolyn Morehouse, P.E.
Chief Engineer

Adoption Date: 7/17/2020

Last Code and Stds. Review
By: KLH Date: 7/8/2020

Next Code and Standards Review date: 7/8/2030

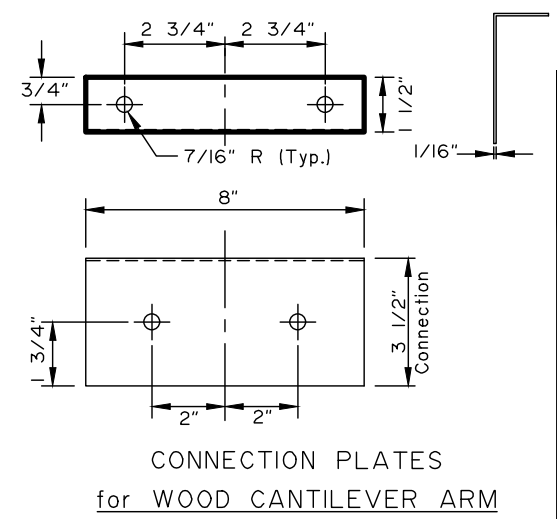
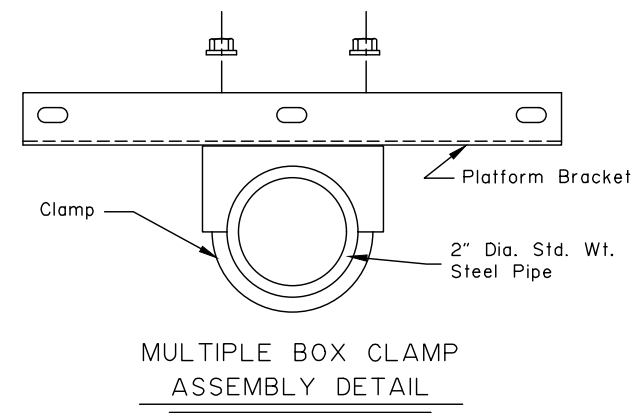
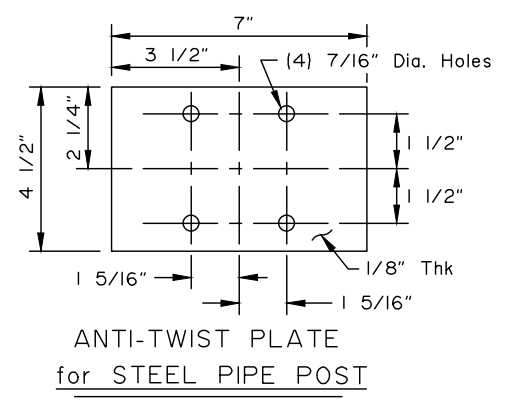
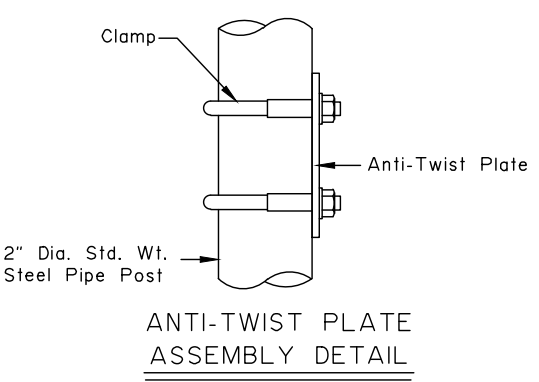
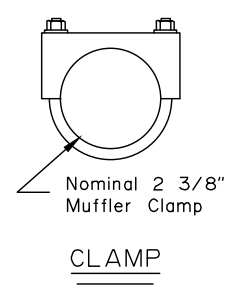
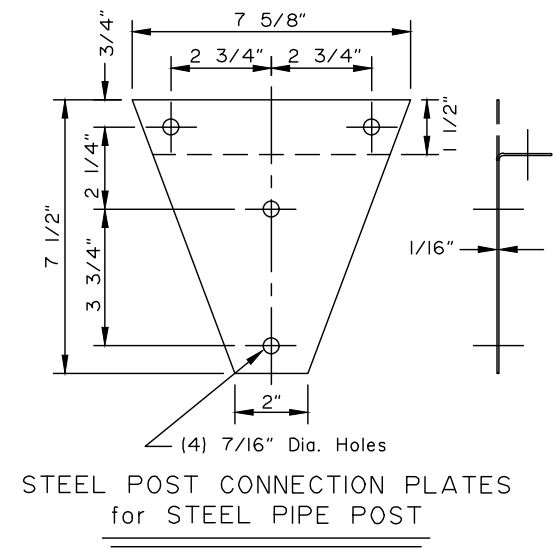
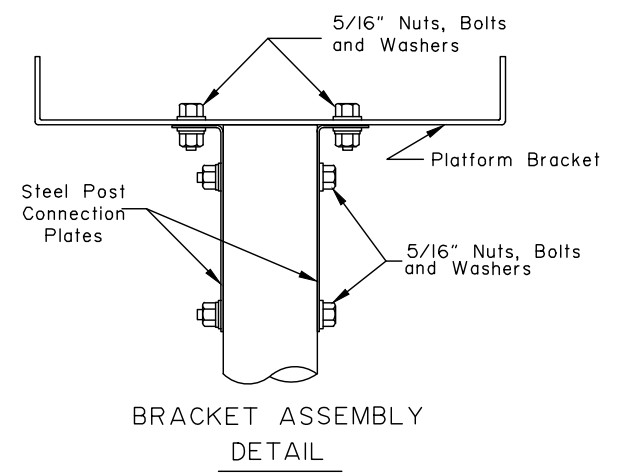
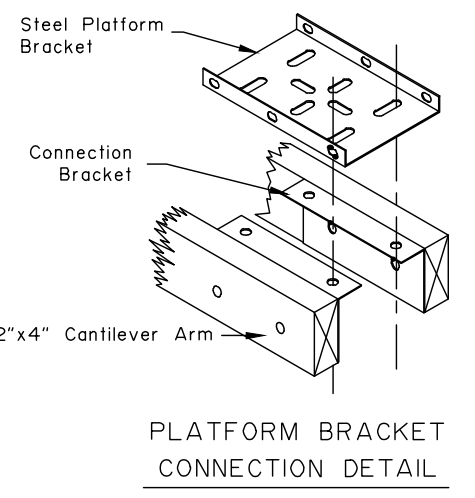
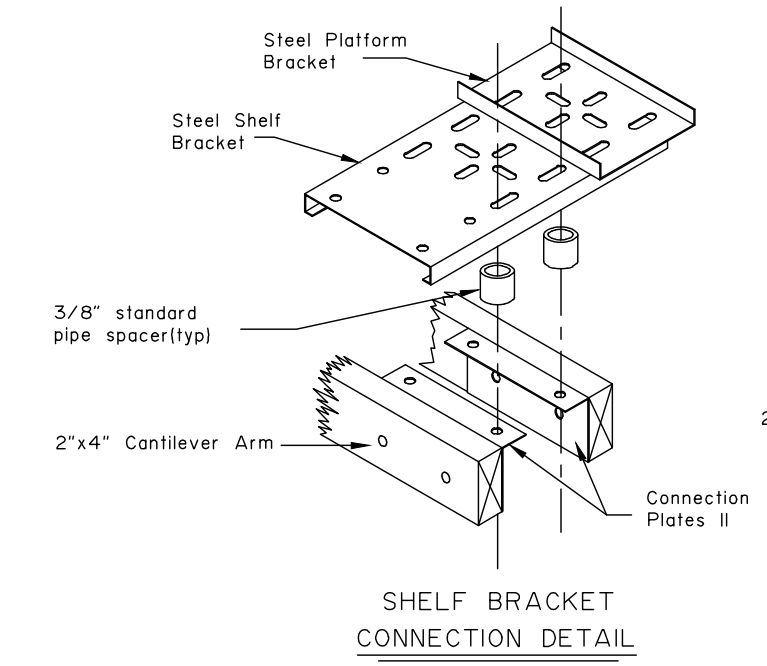
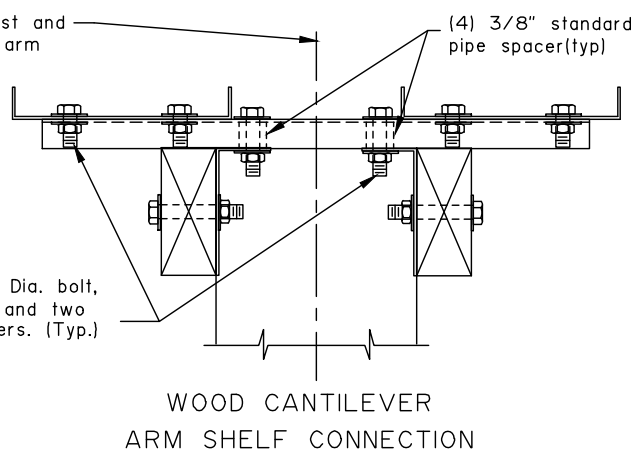
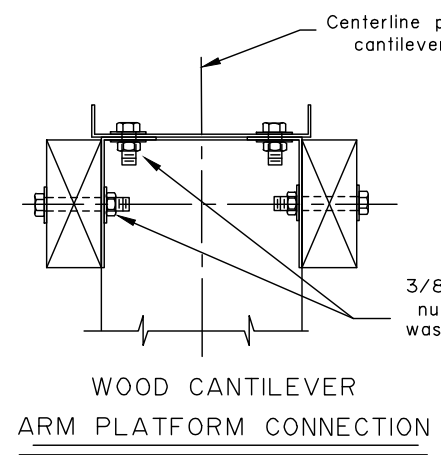
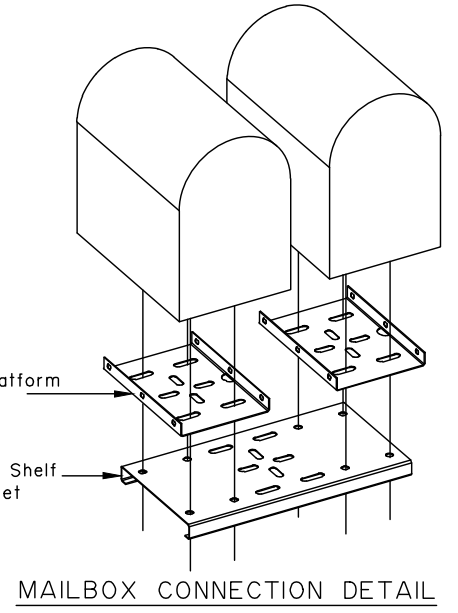
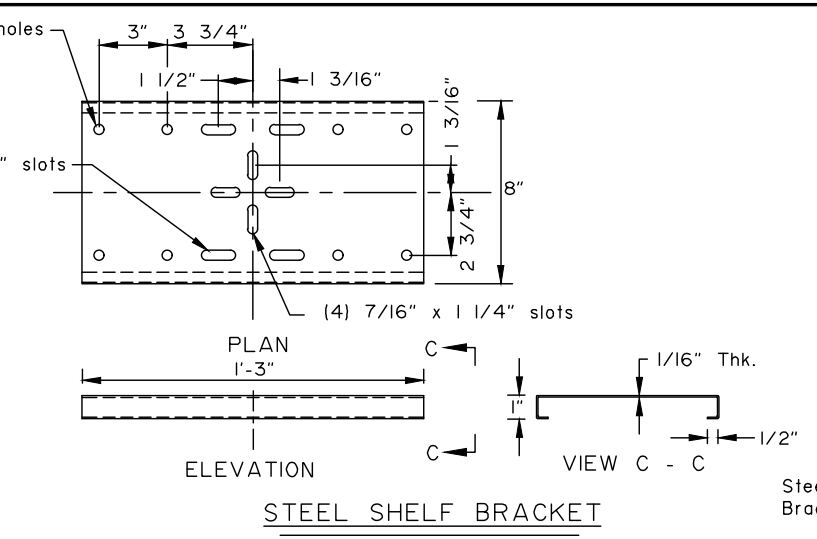
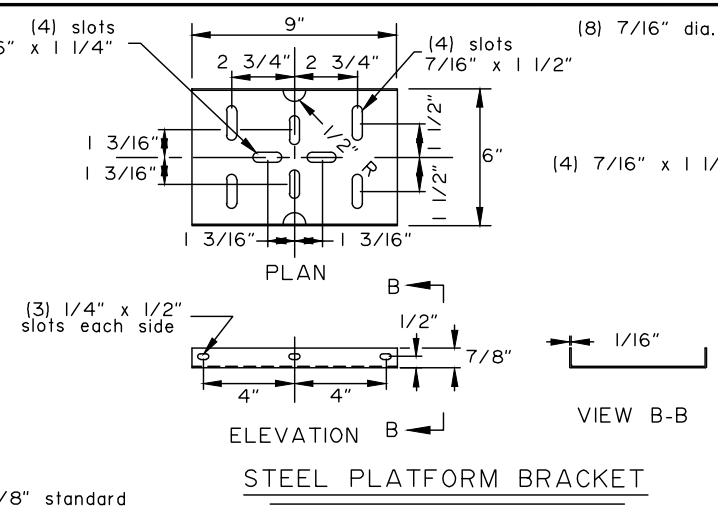
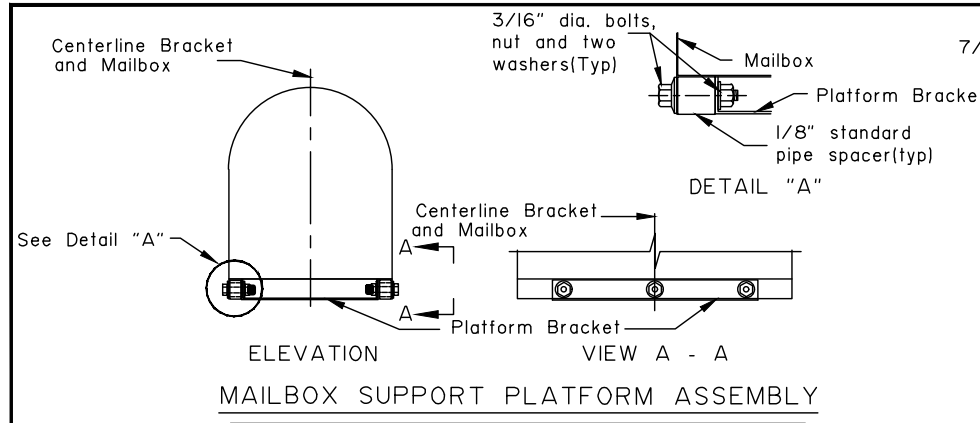

State of Alaska DOT&PF
ALASKA STANDARD PLAN

MAILBOX MOUNTING AND ANCHORING DETAILS

Adopted as an Alaska Standard Plan by: *Carolyn Morehouse*
Carolyn Morehouse, P.E.
Chief Engineer

Adoption Date: 7/17/2020

Last Code and Stds. Review By: KLH Date: 7/8/2020

Next Code and Standards Review date: 7/8/2030

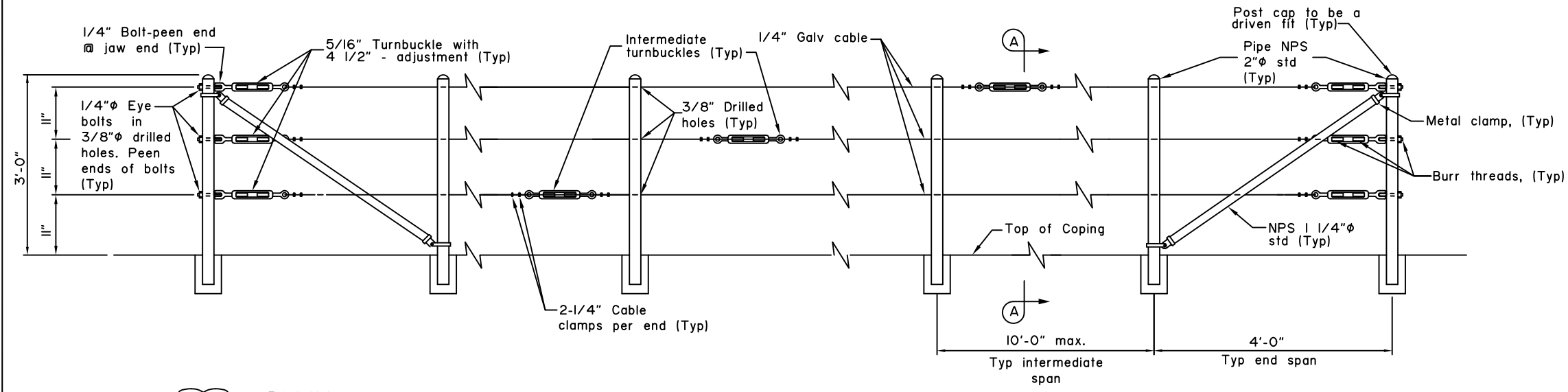

ELEVATION

CONSTRUCTION NOTES:

1. Place intermediate turnbuckles in adjacent spans. Maximum span between turnbuckles is 200'-0".
2. Galvanize all posts, cable and hardware.
3. Install posts plumb.
4. Alignment of holes in posts may vary to conform to slope of top of wall.
5. Line posts shall be braced horizontally and trussed diagonally in both directions at intervals not to exceed 1000'-0" and at each end.
6. Typical end spans, braced in both directions, shall be constructed at changes in line where the angle of deflection is 15° or more.
7. Provide thimbles at all cable loops.

DESIGN NOTES:

1. This rail is not intended for use where pedestrians or bicyclists are normally present.
2. This rail is intended for use where M&O personnel, inspectors, or engineers may be working at the top of a wall.

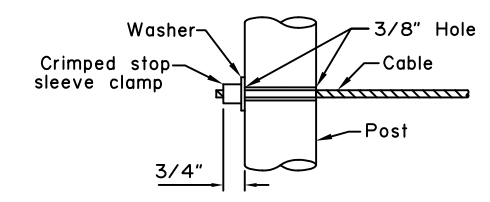

ALTERNATIVE DEAD END ANCHORAGE

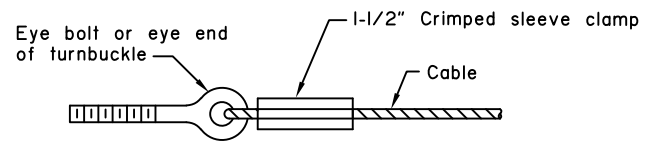

ALTERNATIVE CABLE CONNECTION

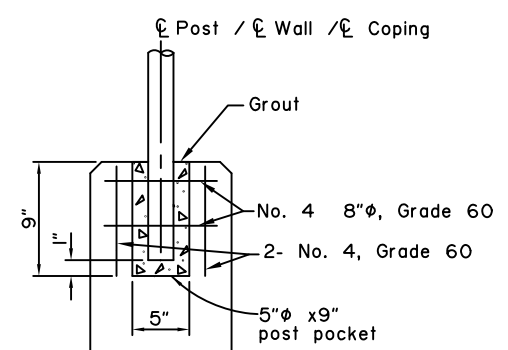

POST POCKET

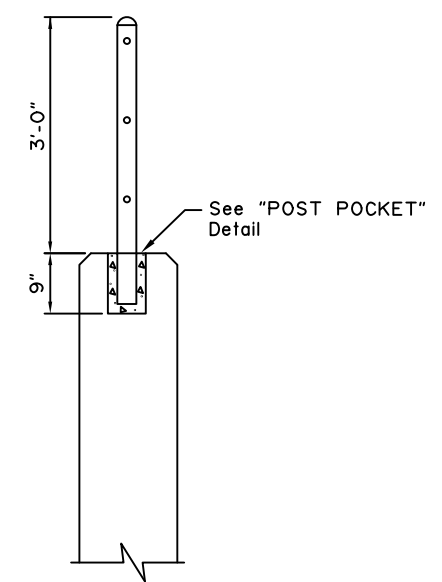

SECTION A-A
CAST IN WALL OR COPING

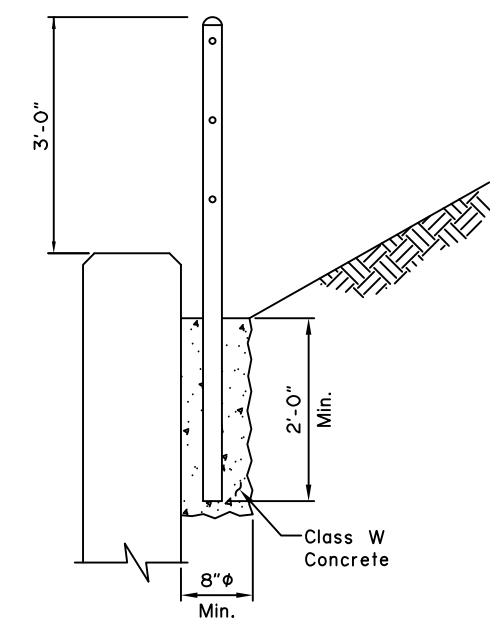

SECTION A-A
BEHIND WALL WITHOUT GUTTER

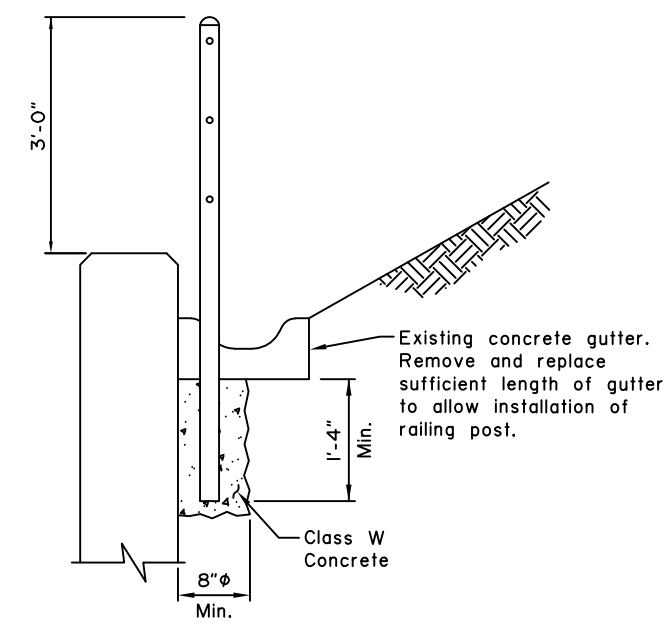

SECTION A-A
BEHIND WALL WITH GUTTER

No Scale

State of Alaska DOT&PF
ALASKA STANDARD PLAN

CABLE SAFETY RAIL

Adopted as an Alaska Standard Plan by: *Kenneth J. Fisher*
Kenneth J. Fisher, P.E.
Chief Engineer

Adoption Date: 02/08/2019

Last Code and Stds. Review By: Date:
Next Code and Standards Review date: 02/08/2029

GENERAL NOTES

1. See the standard specifications for the aluminum alloys that you may use for sign sheeting and wind framing members.
2. Fabricate all signs from 0.125" thick aluminum sheeting.
3. Sign fabricators may use alternates to the zee shaped framing member with approval of the engineer, if the frame manufacturer certifies their design equals or exceeds the strength of the zee shaped design.
4. Install one piece wind framing members on all signs up to 23.5' wide. Use one splice in each wind frame on all signs wider than 23.5'. Locate splices at least 18" from all posts and panel edges. Stagger splices in adjacent framing members at least 8.0' apart.
5. Attach wind framing members with rivets or with an engineer approved, double sided, high strength, adhesive tape. Clean and handle sheeting and framing members and apply tape in accordance with the tape manufacturer's written instructions. Install two rivets in both ends of each framing member.
6. Use 3/16" diameter rivets conforming to aluminum alloy 6061-T6 for cold driven rivets, or aluminum alloy 6061-T43 for hot driven rivets.
7. Sign fabricators may use sign panels extruded with integral framing with approval of the engineer, if the manufacturer certifies their design equals or exceeds the strength of the 0.125" thick panel with framing attached to it.
8. Frame all signs taller than 8.0' with five wind framing members located (H-0.15)/4 spaces. If needed, make a horizontal splice at the middle wind frame.
9. Do not use round pipes for sign supports.

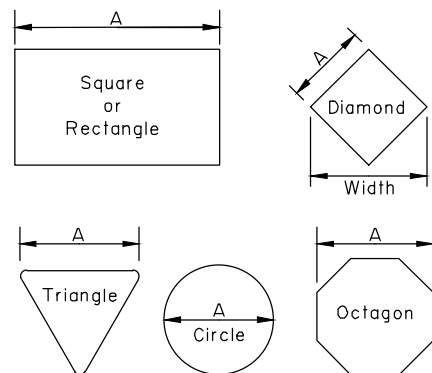
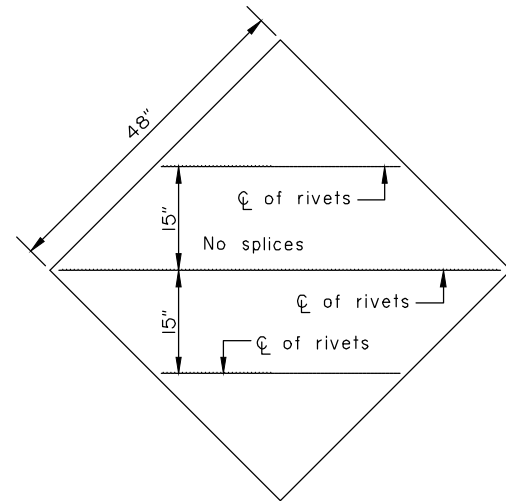

Maximum size unframed signs using 0.125" thick aluminum sheeting.	
Sign Shape	A
Squares, Shields, and Route Markers	48"
Rectangles	48"
Diamonds	48"
Triangles	48"
Rounds and Octagons	48"

Install wind framing on all signs that exceed the dimensions listed.

LIGHT SIGNS

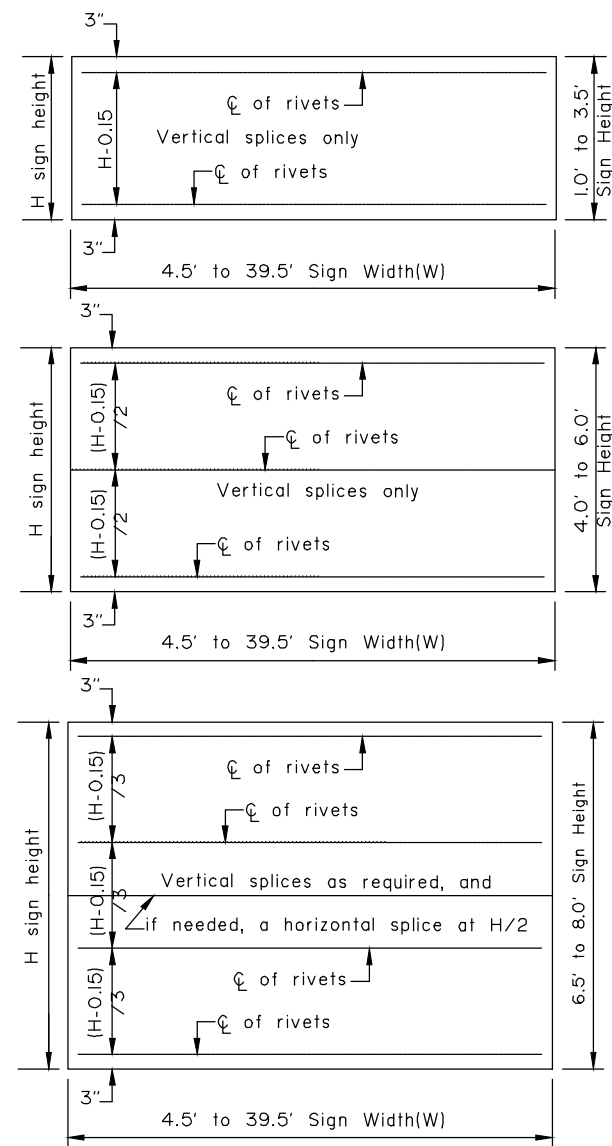

WIND FRAMING LOCATIONS

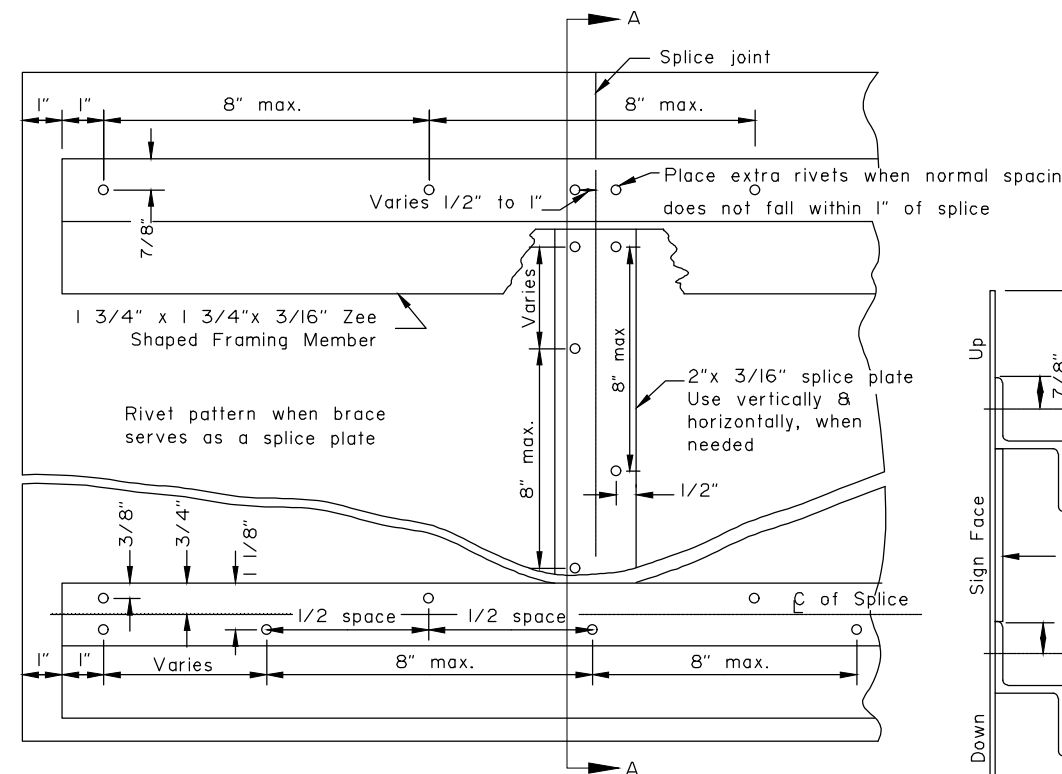

RIVET DETAIL FOR ZEE SHAPED WIND FRAMING & SPLICE PLATE

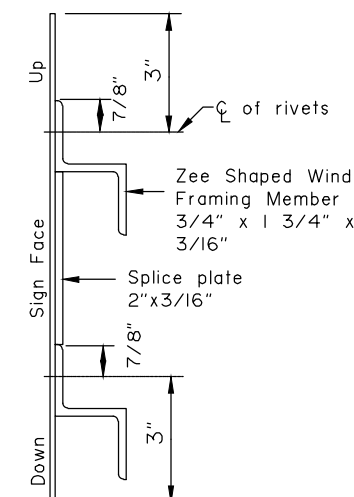

SECTION A-A

Note: Drawing not to scale

State of Alaska DOT&PF
ALASKA STANDARD PLAN
SIGN FRAMING

Adopted as an Alaska Standard Plan by: *Carolyn Morehouse*
Carolyn Morehouse, P.E.
Chief Engineer

Adoption Date: 7/17/2020

Last Code and Stds. Review By: WTH Date: 7/8/2020

Next Code and Standards Review date: 7/8/2030

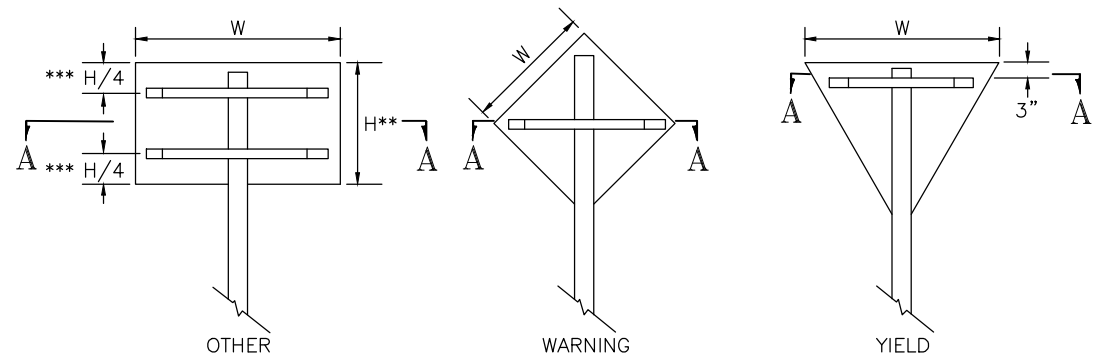

*** Use one brace when $H \leq 18"$
 Use two braces when $18" < H < 48"$
 Use three braces when $H \geq 48"$

** Position of brace may be varied to match
 Pre-drilled mounting holes in panel

SIGN BRACING PLACEMENT

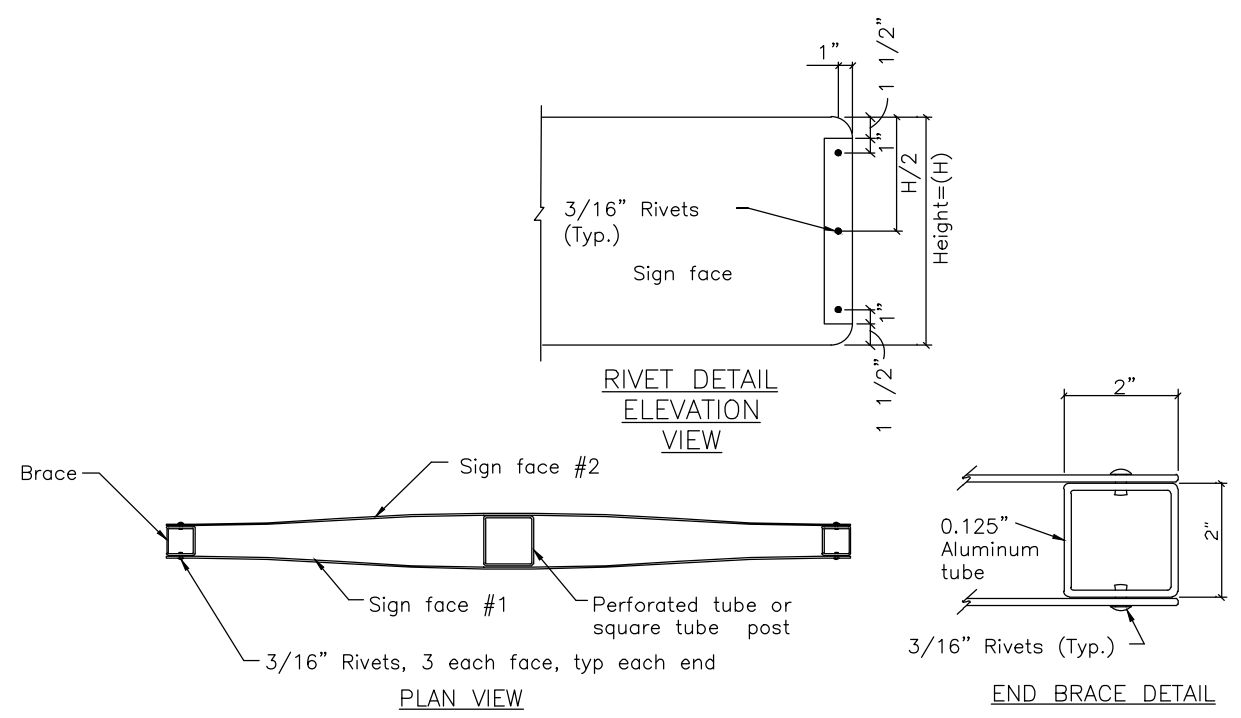

SMALL STREET NAME SIGN (D3-1, D3-1A, D3-1D) BRACING DETAILS

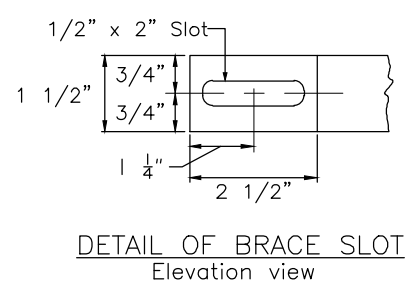

DETAIL OF BRACE SLOT
Elevation view

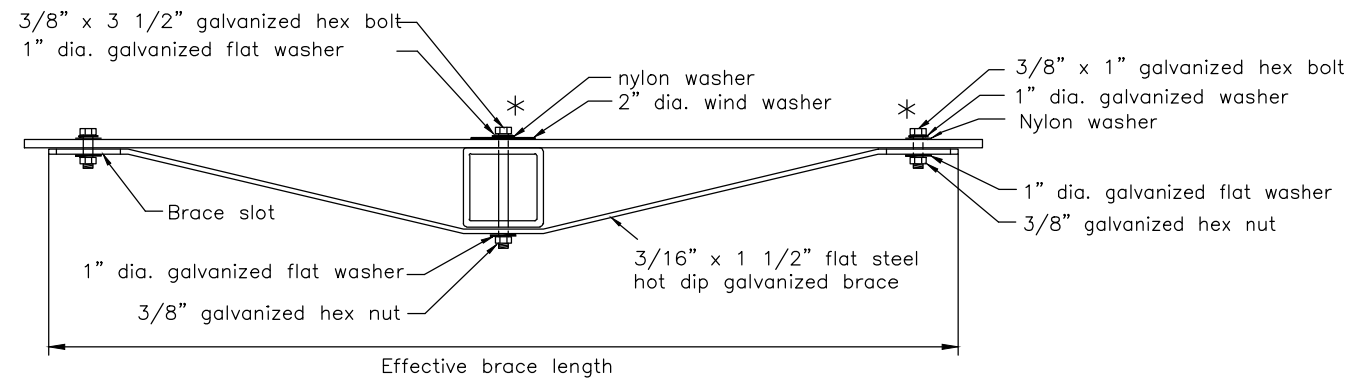

TUBE POST SIGN BRACING SECTION A-A
Plan view

* Adjust location of bracing so that bolts and washers will miss the sign legend

Sign Width(W)	Effective Brace Length		
	Warning	Yield	Other
30"	36"	24"	24"
36"	42"	30"	30"
42"	48"	-	36"
48"	Two posts	36"	42"

< 30" No bracing required and use square tube

Note: Drawing not to scale

State of Alaska DOT&PF
 ALASKA STANDARD PLAN

BRACING FOR SIGNS
 MOUNTED ON SINGLE POST

Adopted as an Alaska Standard Plan by: *Carolyn Morehouse*
 Carolyn Morehouse, P.E.
 Chief Engineer

Adoption Date: 7/17/2020

Last Code and Stds. Review
 By: WTH Date: 7/8/2020

Next Code and Standards Review date: 7/8/2030

S-01.02

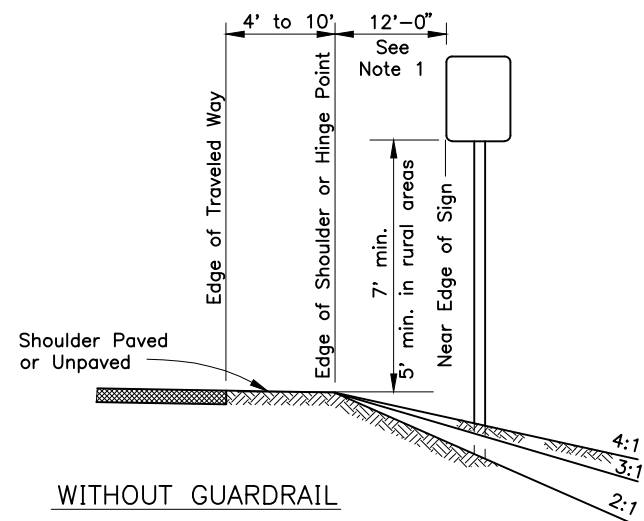

WITHOUT GUARDRAIL
SUBGRADES OVER 28', ALL SLOPES

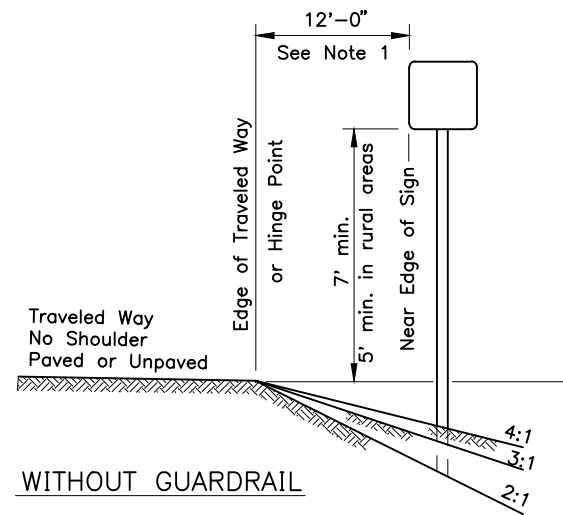

WITHOUT GUARDRAIL
SUBGRADES 24' TO 28', ALL SLOPES

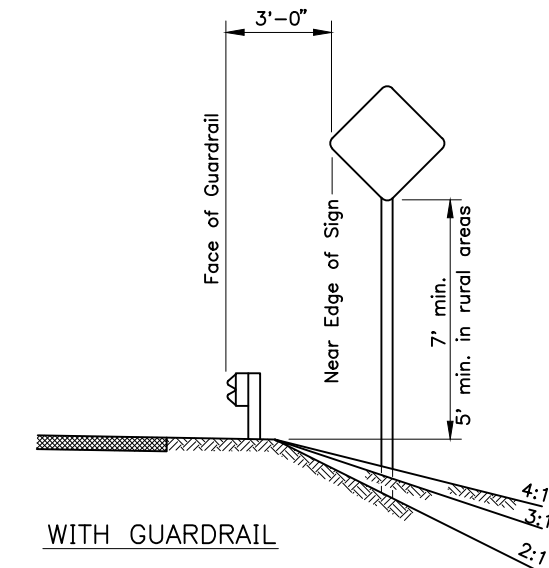

WITH GUARDRAIL
ALL SUBGRADES, ALL SLOPES

GENERAL NOTES

1. Unless shown otherwise on the plans, the standard sign offset is 12'. The minimum is 6' where shoulder width is 6' or greater.
2. Add 6" to mounting height on unpaved roads.
3. If signs extend over bike paths, the minimum vertical clearance is 8' 0".
4. When signs are placed 30' or more from the edge of traveled way, mount them with the bottom of the sign at least 5' above the road surface at the near edge of the road.
5. When multiple hinged sign supports are used, mount hinges at least 7' above the ground.
6. Minimum mounting height is 7'-0" where parking or pedestrian movements are likely to occur, or where signs extend over sidewalks.
7. For construction signs in rural areas, mounting height shall be 7' minimum.

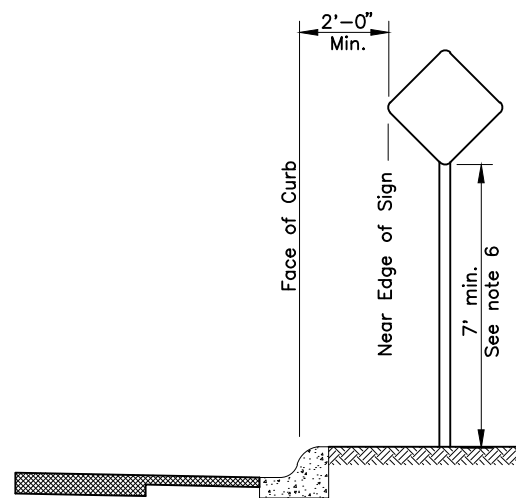

CURB WITHOUT SIDEWALK

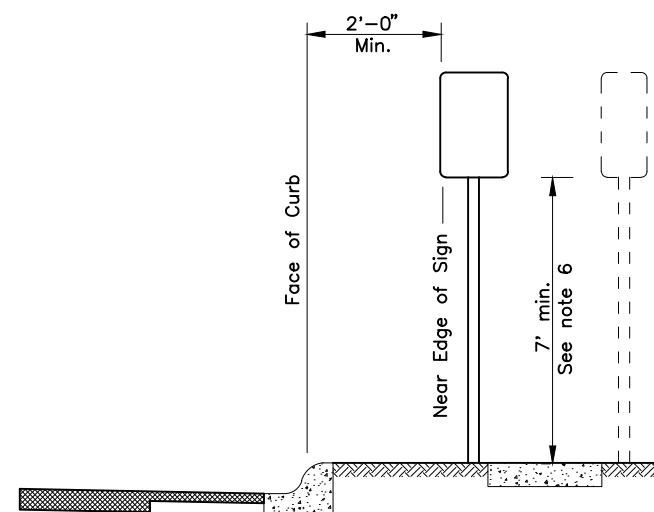

CURB WITH PARKWAY AND SIDEWALK
(If R/W width permits, signs should be placed behind sidewalk.)

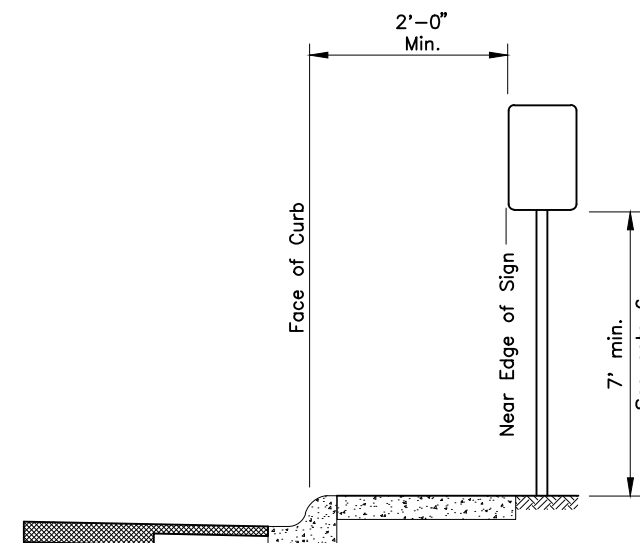

CURB WITH SIDEWALK WITHOUT PARKWAY

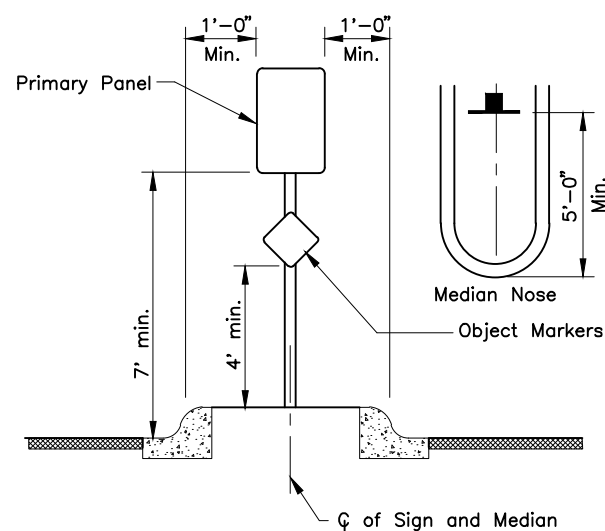

RAISED MEDIANS
Minimum 4' Width for Signing

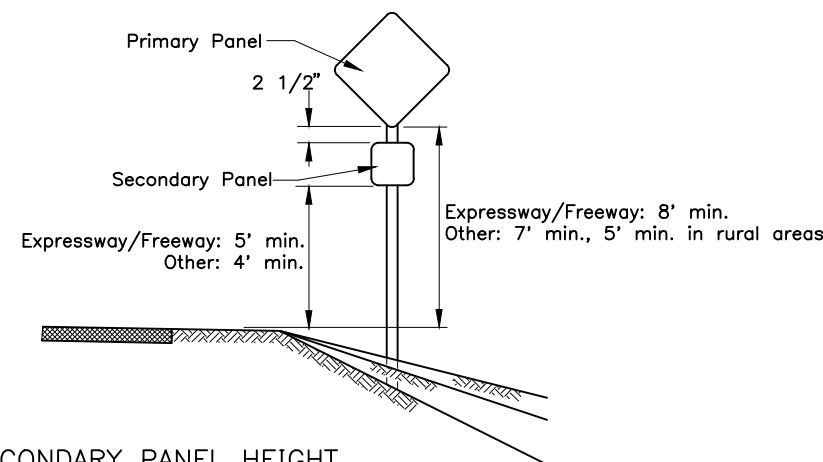

SECONDARY PANEL HEIGHT
ALL TWO PANEL MOUNTING

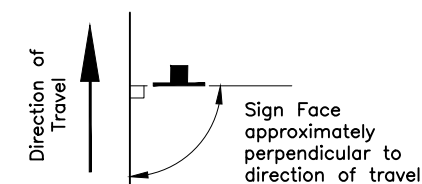

SIGN POSITIONING

State of Alaska DOT&PF
ALASKA STANDARD PLAN

POST MOUNTED SIGN
OFFSET AND HEIGHT

Adopted as an Alaska Standard Plan by *Carolyn Morehouse*
Carolyn Morehouse, P.E.
Chief Engineer

Adoption Date: 7/17/2020

Last Code and Stds. Review
By: KLK Date: 7/8/2020
Next Code and Standards Review Date: 7/8/2030

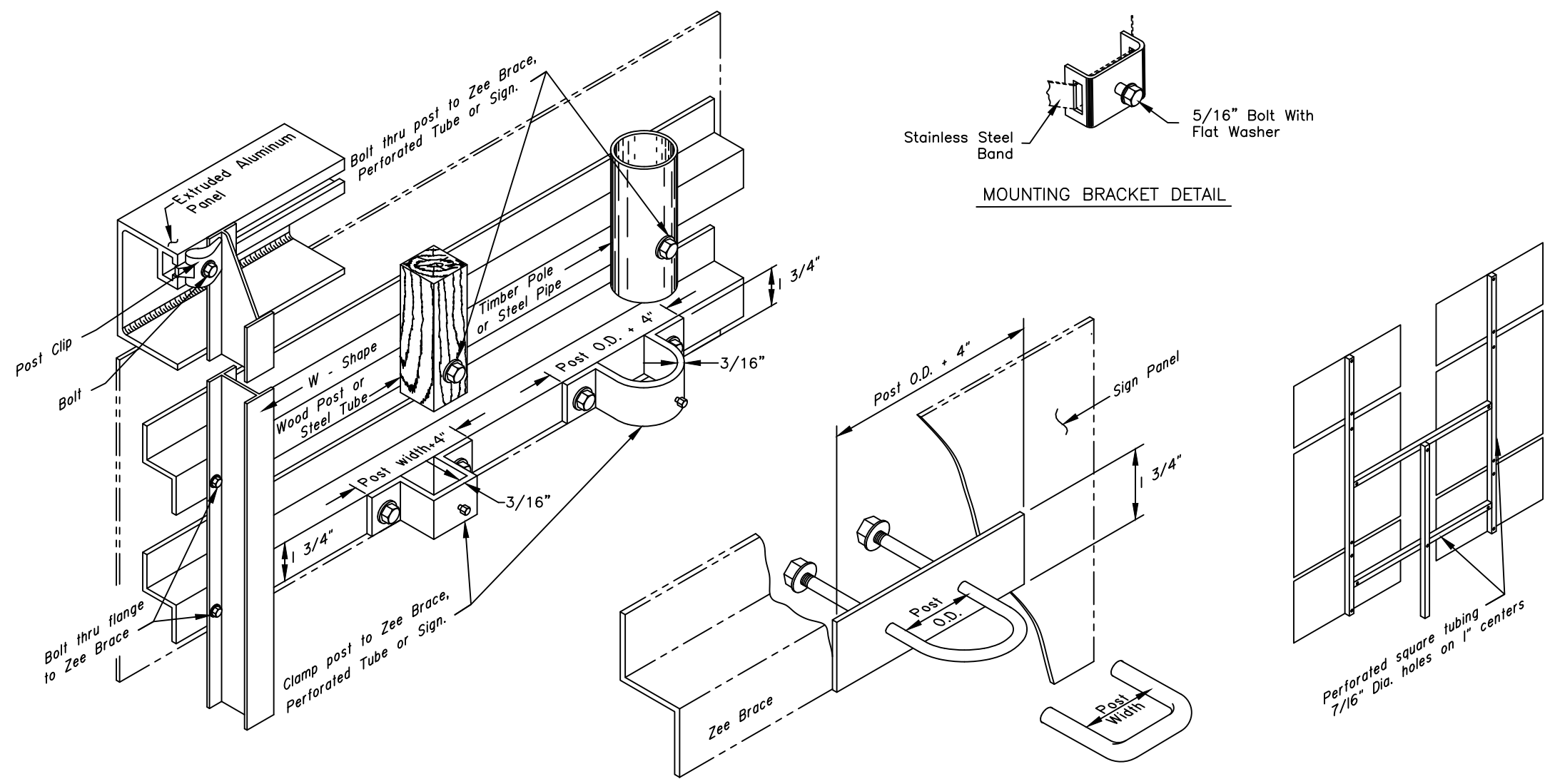
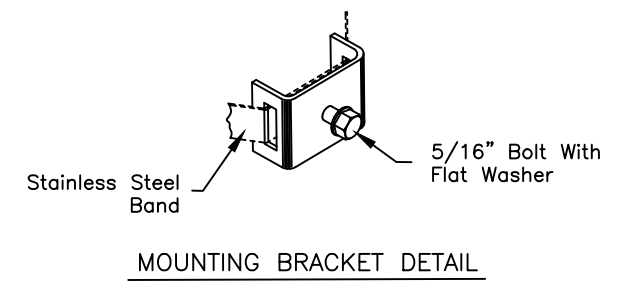
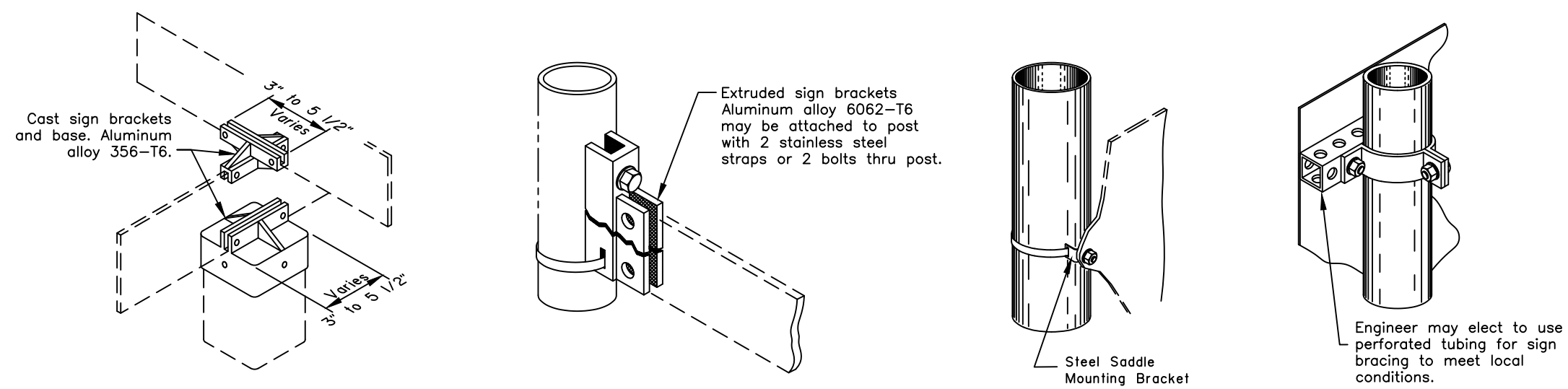

CONSTRUCTION NOTES

1. Details shown indicate general design only. Dimensions and design may vary among manufacturers.
2. Install weather tight caps on all pipe and tube post (except perforated tubing).
3. Protect driven sign posts with drive caps during installation.
4. Bolt braces to posts at each point where they cross posts.
5. Install signs with top of post, mounting brackets, etc. with a minimum of 3" below top of sign.
6. Paint all sign mounting fasteners on sign face a color closely matching the sign face.
7. Attach all signs, zees and braces mounted to the posts with 5/16" bolts, nuts and washers.
8. Furnish all aluminum nuts, bolts and washers with anodized finish.

FASTENER SPECIFICATION TABLE
(ALL REFERENCES ARE TO ASTM)

FASTENERS		ALUMINUM	STEEL	STAINLESS STEEL
BOLTS	MACHINE	F468 2024-T4	A307	F593
	CARRIAGE "U"	F468 2024-T4	A307	A276 TYPE 304
NUTS	REGULAR	F467 6061-T6	A563	F594
	LOCKING	F467 2017-T4		
WASHERS		F468 2024-T4	F844	A480
POST CLIP		A356-T6	N/A	N/A

State of Alaska DOT&PF
ALASKA STANDARD PLAN

SIGN TO SIGN POST CONNECTION

Adopted as an Alaska Standard Plan by: *Carolyn Morehouse*
Carolyn Morehouse, P.E.
Chief Engineer

Adoption Date: 07/30/2021

Last Code and Stds. Review
By: LRG Date: 07/30/2021

Next Code and Standards Review date: 07/30/2031

GENERAL NOTES

1. Use pole plate assemblies shown here to install signs on tapered mast arms and light poles. Install one pole plate per 10 square feet of sign panel. Use at least two plates for each installation.
 2. Fabricate each pole plate-to-perforated tube adapter (steel plate welded to pipe) using steel plate conforming to ASTM A36 and steel pipe conforming to ASTM A53. Paint these adapters in conformance with section 504 of the Standard Specifications for Highway Construction, latest edition.
 3. Paint the assemblies in accordance with AASHTO standard specification M69.
 4. Attach each pole plate with two bands of 3/4" wide by 0.020" thick stainless steel banding material. Double wrap each band and tighten it until the band stops moving through the buckle.
- Install bolts, nuts and washers conforming to
5. ASTM A325.

NO. OF POLE PLATES	OVERHANG	BETWEEN POLE PLATES	OVERHANG
2	0.2W	1 SPACE AT 0.6W	2 0.2W
3	0.15W	SPACES AT 0.35W	3 0.15W
4	0.125W	SPACES AT 0.25W	1 0.125W
5	0.2W	SPACE AT 0.6W	0.2W

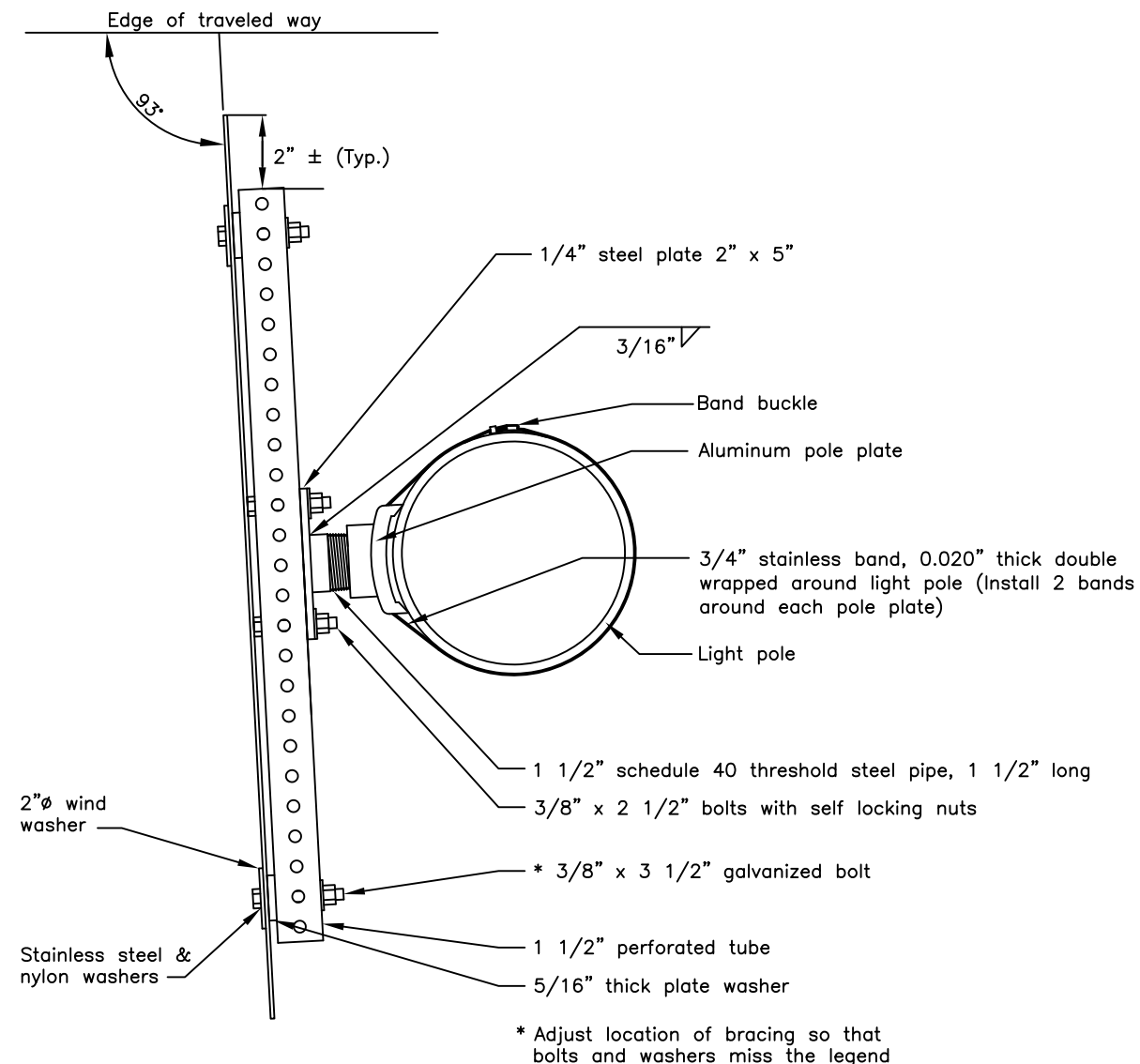

ELECTROLIER SIGN MOUNTING
(PLAN VIEW)

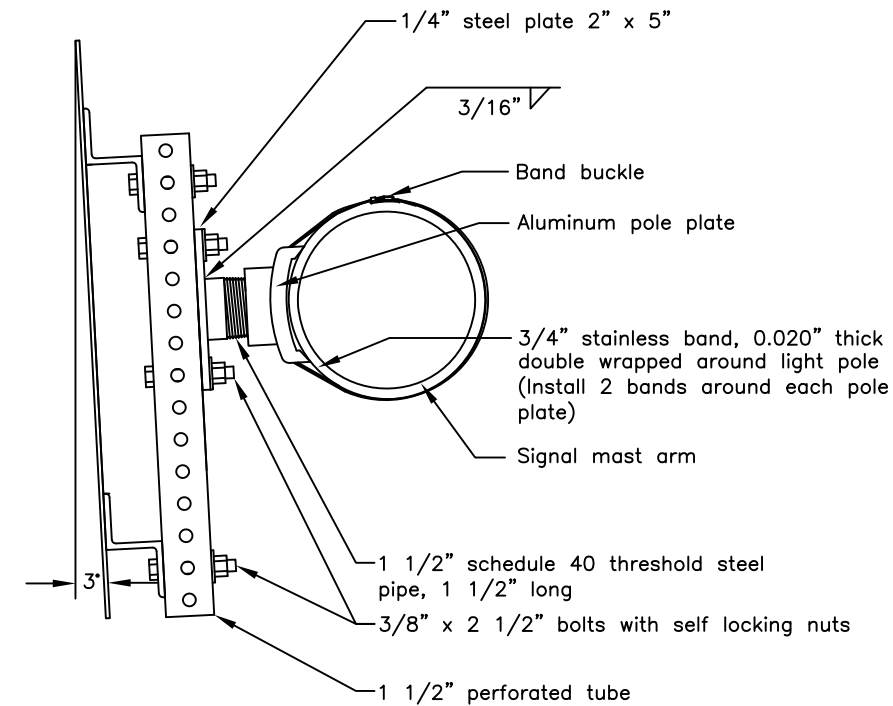

SIGNAL POLE MAST ARM SIGN MOUNTING
(ELEVATION VIEW)

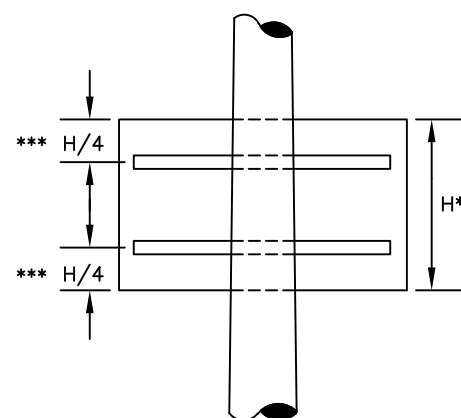

1 1/2" PT brace only when H ≤ 48"

- ** Use two pole plates when H ≤ 48" use three pole plates when H > 48"
- *** When sign panels features predrilled mountings holes, use them to attach the perforated tubes

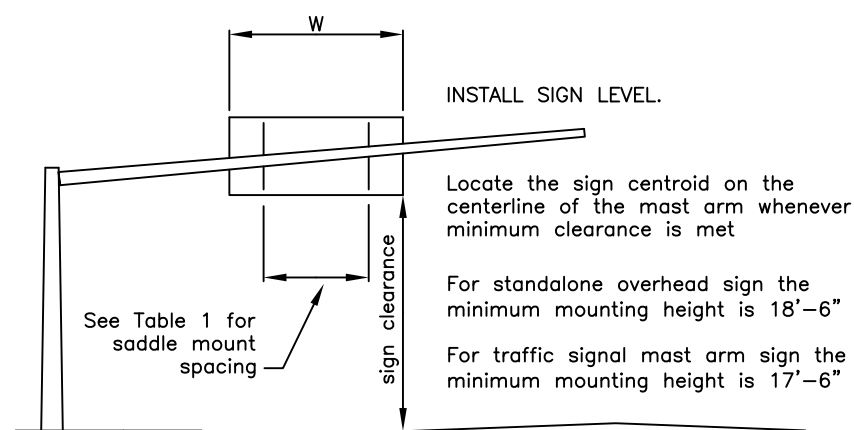
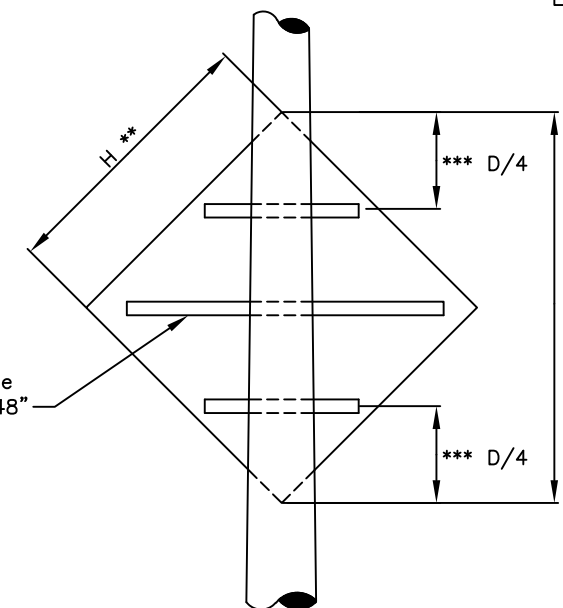

State of Alaska DOT&PF
ALASKA STANDARD PLAN
POLE AND MASTARM
SIGN MOUNTING

Adopted as an Alaska Standard Plan by: *Kenneth J. Fisher*
Kenneth J. Fisher, P.E.
Chief Engineer

Adoption Date: 02/08/2019

Last Code and Stds. Review By: Date:

Next Code and Standards Review date: 02/08/2029

GENERAL NOTES:

1. Sign shall be placed symmetrically around posts and refer to Standard Plan S-00 for sign framing details.
2. See plans for type of post, size and embedment type.
3. To maintain crashworthiness, install no more than the number of P.S.T.s or wood posts specified in the tables within 7' of each other.
4. Concrete shall be class B.
5. Do not use the supports on this drawing for multiple support signs if supports are separated by more than 7 feet.
6. Treat all field cuts and field drilled holes in wood posts in accordance with Section 730-2.04 of the Standard Specifications.

SIGN POST SPACING NOTES:

1. Install sign support in accordance with the table below, unless otherwise required by plans or specifications.
2. Exceptions:
 - a. Use one post for all E5-1 gore signs, regardless of width.
 - b. Use one 2.5" P.S.T. for all STOP signs, with or without street name signs.
3. Supports placed within 7' of each other must be acceptable for that use. See tables below for the sizes of wood posts and P.S.T.s that may be used within 7'. See Manufacturer's documentation for breakaway couplings and tubes that may be used within 7'.
4. See Standard Plan S-31 for frangible couplings, hinges, and foundations for tube and W-shape sign supports.

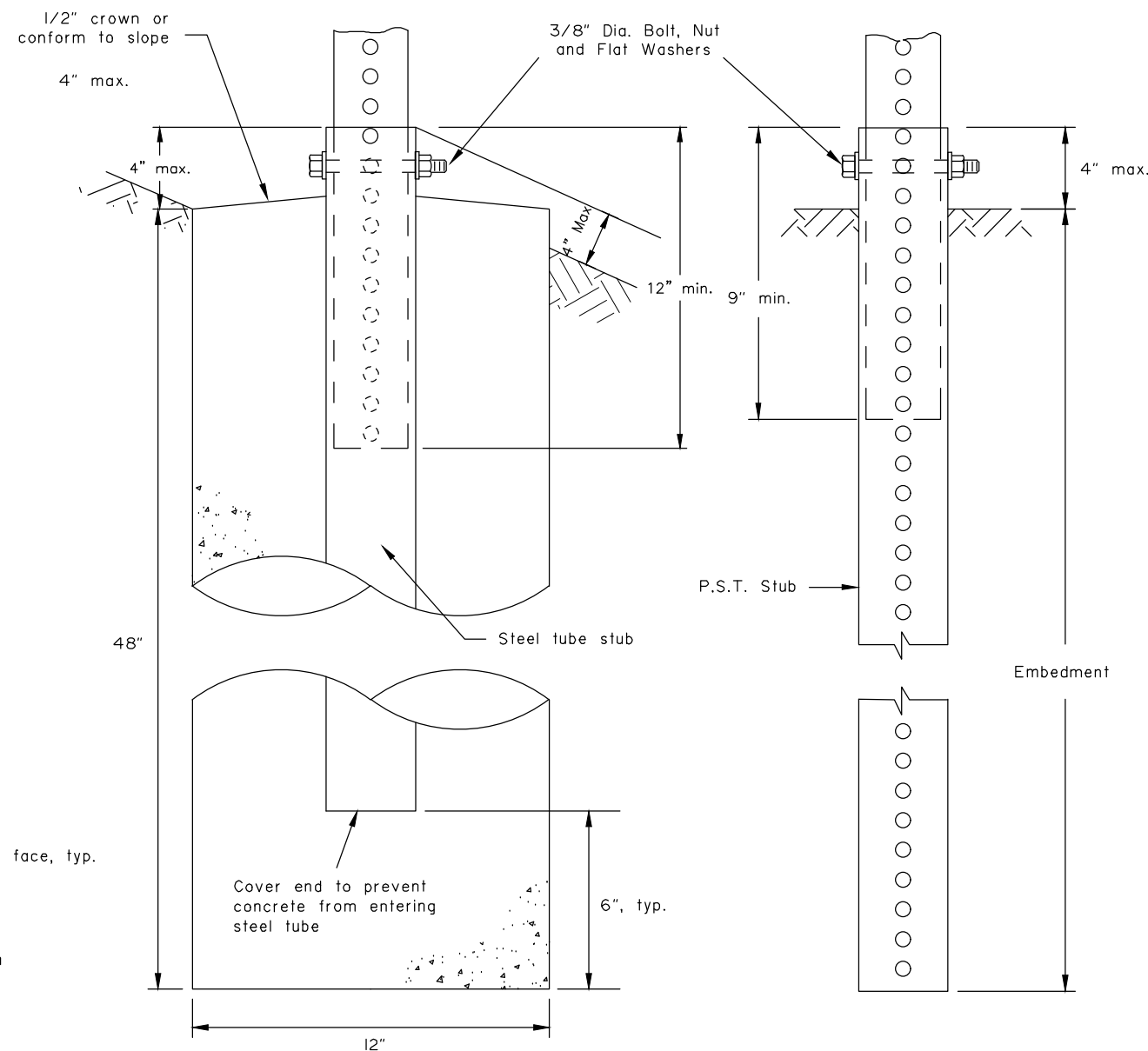
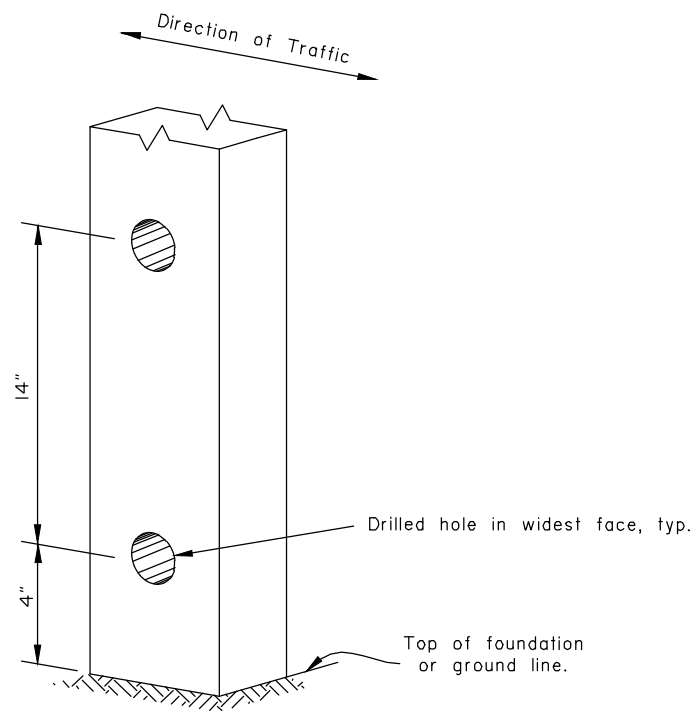
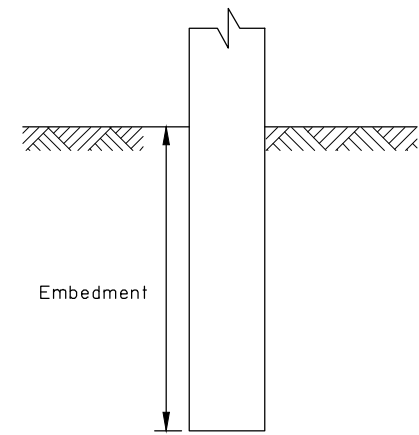

SLEEVE TYPE
CONCRETE FOUNDATION

SLEEVE TYPE*
SOIL EMBEDMENT

WOOD SIGN POSTS			
SIZE	HOLE DIA.	EMBEDMENT*	NO. OF POSTS WITHIN 7 Ft. PATH
4"x4"	NONE	4'-1"	2
4"x6"	1 1/2"	5'-3"	2
6"x6"	1 1/2"	4'-9"	1
6"x8"	3"	4'-9"	1

* Embedment depth applies in both strong and weak soil.

WOOD POSTS

PERFORATED STEEL TUBES (P.S.T.)		
POST SIZE	Embedment Depth	No. of P.S.T.s permitted within 7 ft path
1 1/2" x 1 1/2"	4'-8"	2
1 3/4" x 1 3/4"	4'-6"	2
2" x 2"	4'-3"	2
2 1/4" x 2 1/4"	5'-0"	1
2 1/2" x 2 1/2"	4'-6"	1

* Use 3"x3"x3/16" Stub for 2 1/2"x2 1/2" PST Applications.

PERFORATED STEEL TUBE (PST) POSTS

TUBE SIGN POST SPACING								
Sign Width (feet)	No. of Posts	Distance Between Posts	Sign Overhang	Post Type				Notes
				P.S.T.	Wood	Steel Tube	W-Shape	
0.5 to 4.0	1	-	0.5W	X	X	X		See Note 2.
4.5 to 10.0	2	0.6W	0.2W	X	X	X		See Note 3.
10.5 to 11.0	2	6	Varies	X	X	X		See Note 3.
11.5 to 13.0	2	8	Varies				X	
13.5 to 20.0	2	0.6W	0.2W				X	
20.5 to 22.5	3	8	Varies				X	
23.0 to 29.5	3	0.35W	0.15W				X	
30.0 to 31.5	4	8	Varies				X	
32.0 to 40.0	4	0.25W	0.125W				X	

TUBE SIGN POST SPACING

Note: Drawing not to scale

State of Alaska DOT&PF
ALASKA STANDARD PLAN
LIGHT SIGN STRUCTURE
POST EMBEDMENT

Adopted as an Alaska Standard Plan by: *Carolyn Morehouse*
Carolyn Morehouse, P.E.
Chief Engineer

Adoption Date: 7/17/2020

Last Code and Stds. Review
By: WTH Date: 7/8/2020

Next Code and Standards Review date: 7/8/2030

NOTE:
Install hinges when more than one post is used to support a sign. Do not install hinges on single post installations.

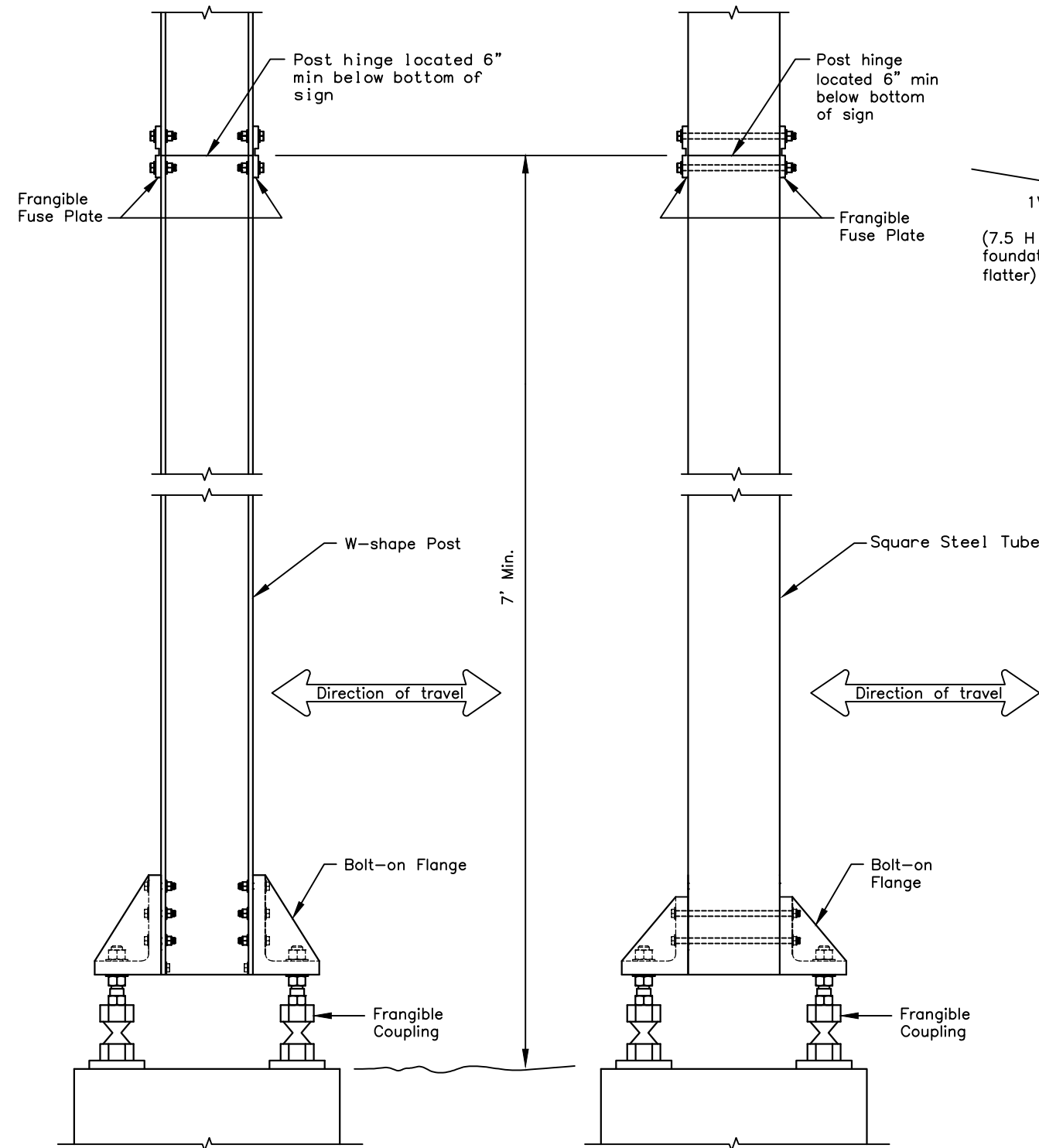

FRANGIBLE COUPLING SYSTEM
FOR W-SHAPE POST

FRANGIBLE COUPLING SYSTEM
FOR SQUARE STEEL TUBES

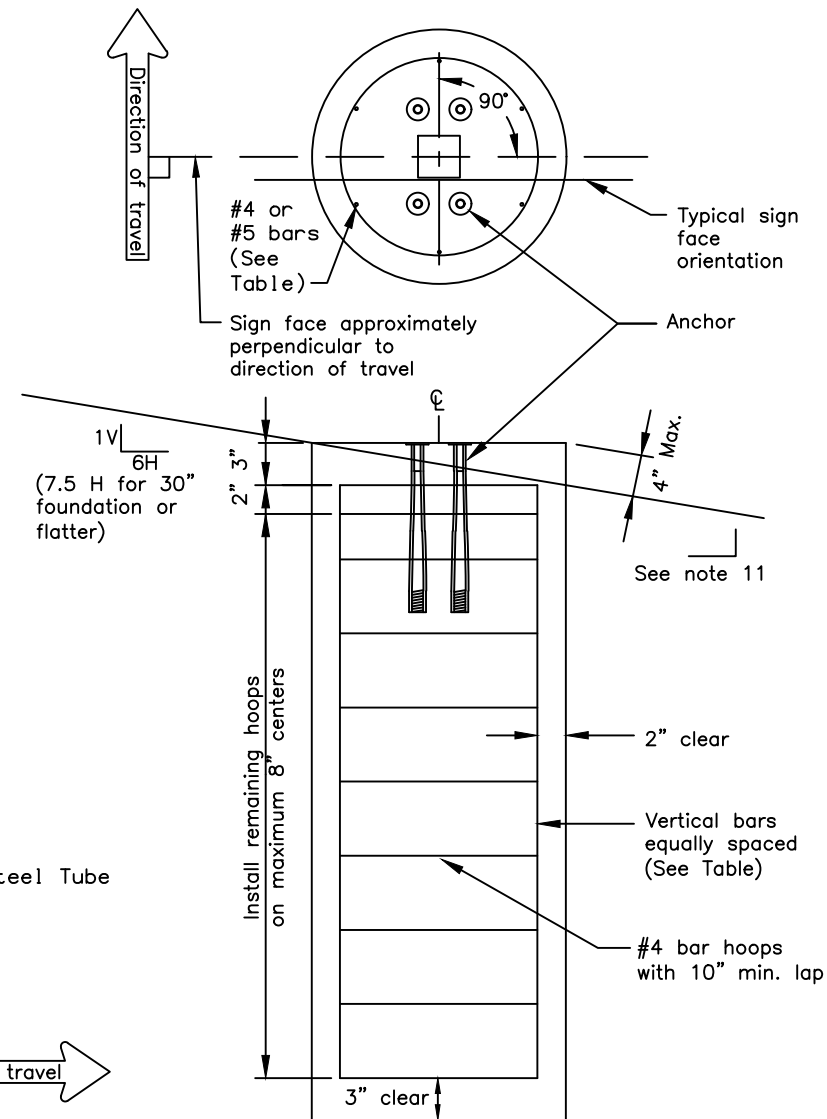

SIGN POST FOUNDATION
See Table for depth and diameter

POST SIZE & TYPE	FOUNDATION *			REINFORCEMENT			
	DIA.	MIN. DEPTH	CY ³ CONC.	VERTICAL BARS QTY. SIZE	HOOPS QTY. SIZE	HOOPS DIA.	
2 1/2" TUBE	1'-6"	6'-0"	0.39	7 #5	5'-6"	10 #4	1'-2"
3" TUBE	1'-6"	6'-0"	0.39	7 #5	5'-6"	10 #4	1'-2"
3 1/2" TUBE	1'-6"	6'-0"	0.39	7 #5	5'-6"	10 #4	1'-2"
4" TUBE	2'-6"	6'-0"	1.09	8 #8	5'-6"	10 #4	2'-2"
4 1/2" TUBE	2'-6"	6'-0"	1.09	8 #8	5'-6"	10 #4	2'-2"
5" TUBE	2'-6"	6'-0"	1.09	8 #8	5'-6"	10 #4	2'-2"
W6 x 9	2'-6"	6'-0"	1.09	8 #8	5'-6"	10 #4	2'-2"
W6 x 12	2'-6"	6'-0"	1.09	8 #8	5'-6"	10 #4	2'-2"
W6 x 15	3'-0"	6'-6"	1.70	8 #11	6'-0"	12 #4	2'-8"
W6 x 30	3'-0"	7'-6"	1.96	8 #11	7'-0"	13 #4	2'-8"

FOUNDATION TABLE

* Foundations sized for use where there are no loose, high moisture, or fine grained soils.

GENERAL NOTES

1. Furnish sign posts with NCHRP 350 compliant frangible couplings designed to break away safely when struck from any direction. There is no MASH compliant device at this time. See SPDR report for more info.
2. Furnish frangible coupling systems with bolt-on flanges.
3. Details on this sheet illustrate only the general components of a frangible coupling system, and are not intended to specify a particular product.
4. Install frangible fuse plates as specified by the manufacturer and hinged joints when multiple posts are used to support a sign. Do not use round pipes.
5. Install the components of the breakaway system, including hinges, in accordance with the written instructions of the system manufacturer.
6. Use Class A, B or W concrete conforming to Sections 501 or 550 of the Standard Specifications. Furnish ASTM A615 grade 60 steel bars for concrete reinforcement conforming to AASHTO M31.
7. Spiral reinforcing steel may be substituted for hoops in concrete foundation. Spiral option shall consist of #3 plain spiral with 6" pitch with three flat turns at the top and one flat turn at the bottom.
8. Install the concrete anchors using a rigid template. Locate the anchors on centers and within tolerances specified by the manufacturer.
9. Install the anchors in fresh concrete as recommended by the manufacturer. Adjust the template's final position until it is level. Remove and replace all foundations that need more than 2 shims under any 1 coupling or more than a total of 3 shims under any pair of couplings to plumb the post.
10. Drill the holes for attaching brackets before the sign posts are hot dip galvanized. Test fit templates in the holes to ensure the brackets can be installed square to the posts.
11. Special grading detail and/or shielding may be required to maintain 4" maximum clear distance.

State of Alaska DOT&PF
ALASKA STANDARD PLAN
SIGN POST BASE AND
FOUNDATION

Adopted as an Alaska Standard Plan by: *Carolyn Morehouse*
Carolyn Morehouse, P.E.
Chief Engineer

Adoption Date: 7/17/2020

Last Code and Stds. Review
By: KLK, MJM Date: 7/8/2020
Next Code and Standards Review Date: 7/8/2030

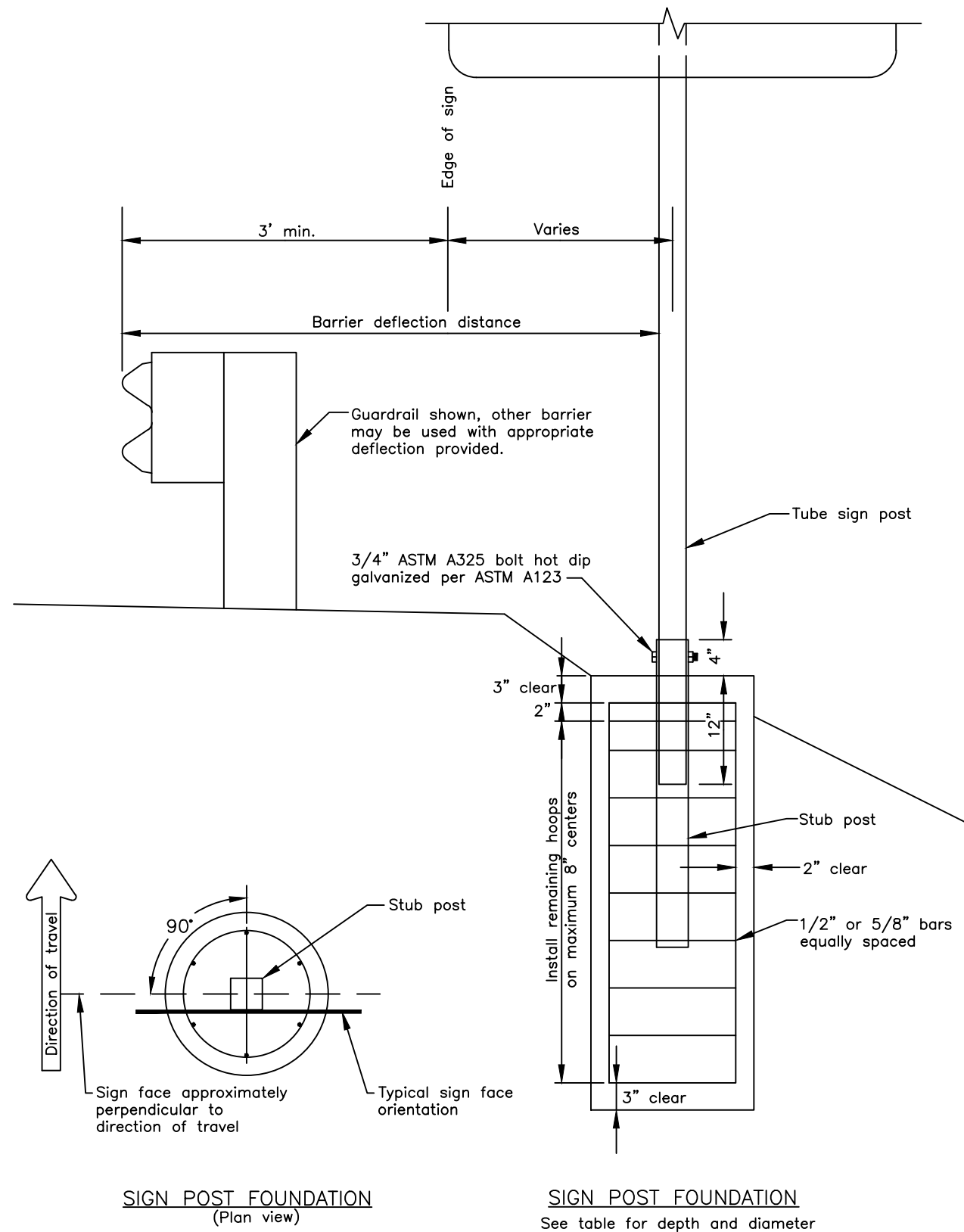

GENERAL NOTES

1. This is a non-crashworthy sign support. It may only be used at locations shielded by a guardrail, barrier, or wall. It may not be used if the sign post is within 20' of the rail and is closer than 75' from the guardrail end post (measured along the rail). For this case use a breakaway sign support. See Standard Plan G-20.
2. Furnish steel tube sign post and stub post that conform to ASTM A500, grade B, and meet ASTM A123 for hot dip galvanizing.
3. Install tubes and stub post with a 0.1875" wall thickness.
4. For Perforated Tubes use Standard Plan S-30.
5. Spiral reinforcing steel may be substituted for hoops in concrete foundation. Spiral option shall consist of No. 3 plain spiral with 6" pitch with three flat turns at the top and one flat turn at the bottom.
6. Use Class A, B or W concrete.

POST SIZE & TYPE	FOUNDATION *			REINFORCEMENT				STUB POST		
	DIA.	MIN. DEPTH	C.Y. CONC.	VERTICAL BARS		HOOPS		SLEEVE		
				QTY.	SIZE	LGTH.	SIZE	DIA.	SIZE	LGTH.
2 1/2" TUBE	1'-0"	4'-6"	0.13	6	#4	4'-0"	#4	8"	3"	3'
3" TUBE	1'-6"	4'-0"	0.25	7	#5	3'-6"	#4	1'-2"	3 1/2"	3'
3 1/2" TUBE	1'-6"	4'-6"	0.27	7	#5	4'-0"	#4	1'-2"	4"	3'
4" TUBE	2'-6"	4'-0"	0.69	8	#8	3'-6"	#4	2'-2"	4 1/2"	3'
4 1/2" TUBE	2'-6"	4'-6"	0.78	8	#8	4'-0"	#4	2'-2"	5"	3'

* Foundation sized for use where there are no loose, high moisture, or fine grained soil.

State of Alaska DOT&PF
ALASKA STANDARD PLAN

SIGN POST BASE AND
FOUNDATION BEHIND
BARRIER
Adopted as an Alaska Standard Plan by: *Carolyn Morehouse*
Carolyn Morehouse, P.E.
Chief Engineer
Adoption Date: 7/17/2020

Last Code and Stds. Review
By: KLK Date: 7/8/2020
Next Code and Standards Review Date: 7/8/2030

S-32.02

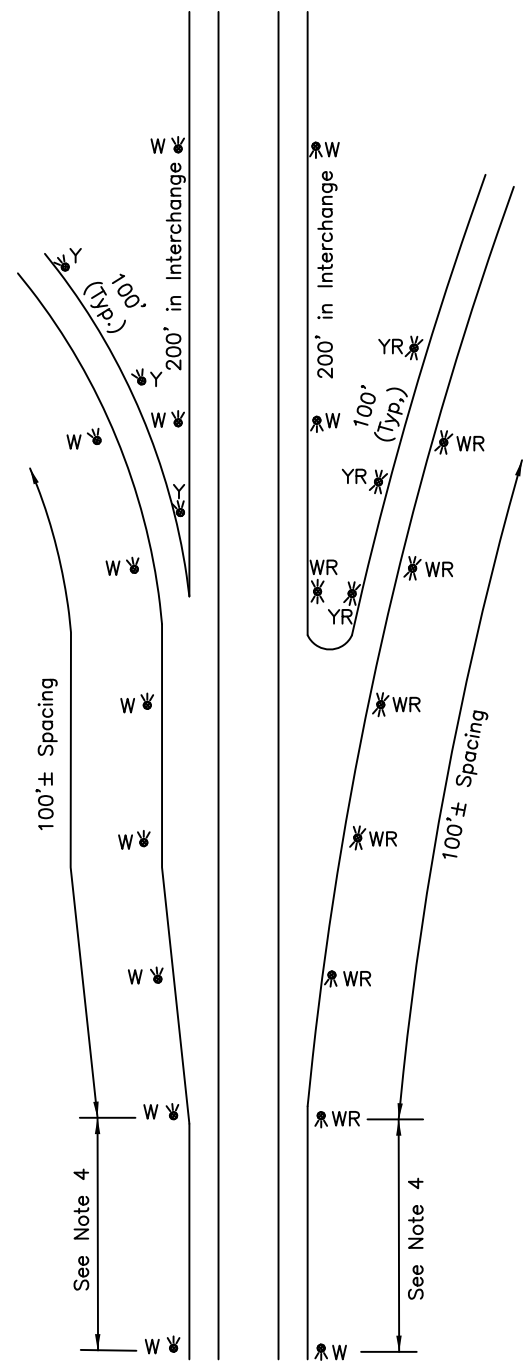

FREEWAY RAMPS

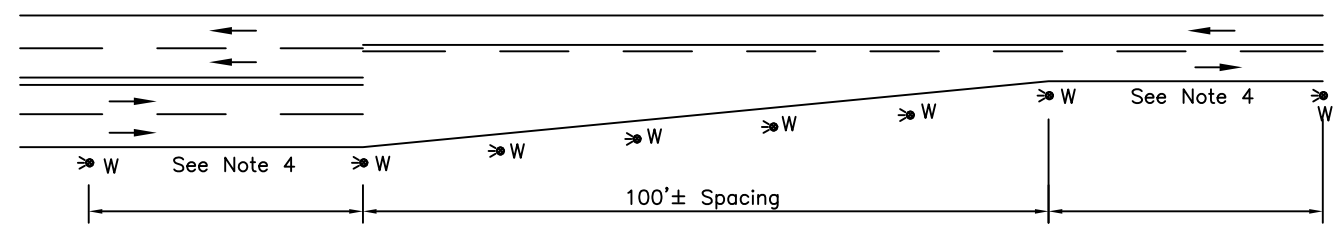

TWO WAY ROAD – LANE REDUCTION
CONDITION

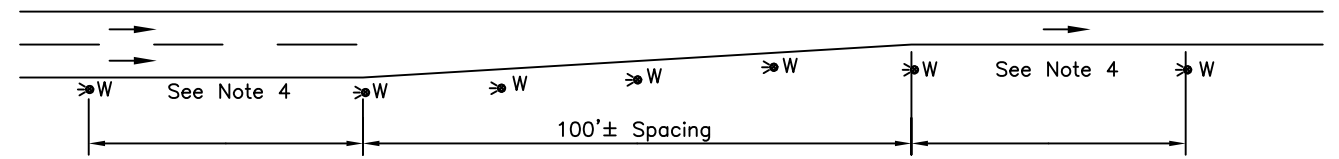

ONE WAY ROAD – RIGHT LANE DROP CONDITION
(FOR LEFT LANE DROP CONDITION USE TYPE Y MARKERS)

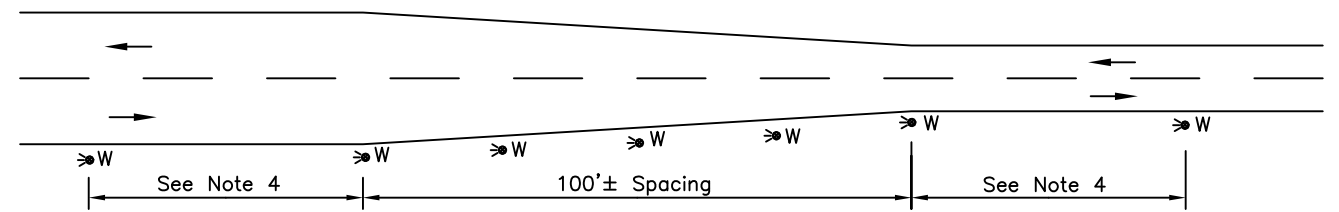

TWO WAY ROAD – NARROWING CONDITION

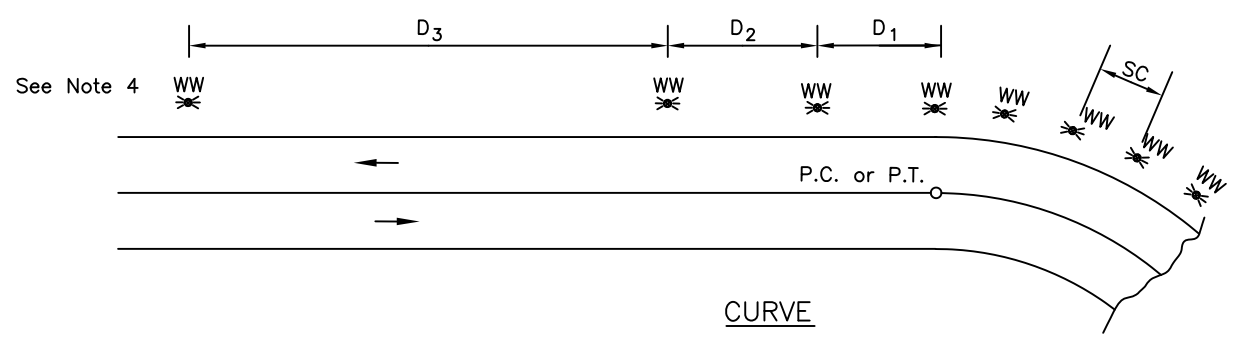

CURVE

RADIUS FT	SPACING ON CURVES			
	SPACING ON CURVE	SPACING IN ADVANCE AND BEYOND CURVE		
		FIRST	SECOND	THIRD
R	SC	D ₁	D ₂	D ₃
1,000'	90'	160'	270'	300'
900'	85'	155'	250'	300'
800'	80'	145'	240'	300'
700'	75'	135'	225'	300'
600'	70'	125'	210'	300'
500'	65'	115'	195'	300'
400'	55'	100'	165'	300'
300'	50'	90'	150'	300'
250'	40'	70'	120'	240'
180'	35'	65'	105'	210'
115'	25'	55'	90'	180'
50'	20'	35'	60'	120'

GUIDE MARKER REFLECTORS		
TYPE	FRONT COLOR	BACK COLOR
WW	WHITE	WHITE
W	WHITE	--
Y	YELLOW	--
YY	YELLOW	YELLOW
WR	WHITE	RED
YR	YELLOW	RED

GENERAL NOTES

1. Maximum spacing on tapers, speed change lanes, pavement transitions, and ramps should be 100'±.
2. On roads with continuous delineation, adjust existing guide marker locations to tie into these configurations.
3. Marker spacing in table has been rounded for ease of calculation and field layout.
4. Spacing on tangents should be approximately 500', 530' maximum. See table for spacing on curves.

State of Alaska DOT&PF
ALASKA STANDARD PLAN

GUIDE MARKER PLACEMENT

Adopted as an Alaska
Standard Plan by: *Kenneth J. Fisher*
Kenneth J. Fisher, P.E.
Chief Engineer

Adoption Date: 02/08/2019

Last Code and Stds. Review
By: Date:

Next Code and Standards Review date: 02/08/2029

T-05.10

Make groove deep enough to put the top of marker 1/16" below pavement surface.

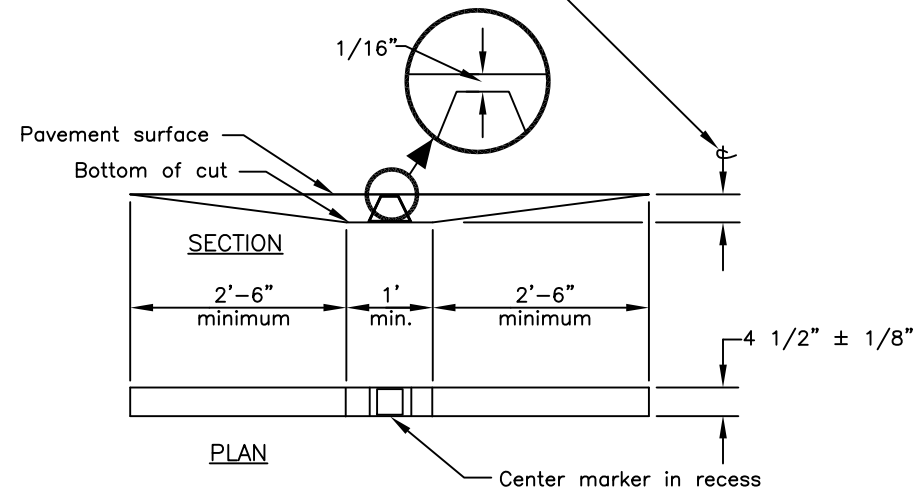

RECESSED PAVEMENT MARKER SLOT

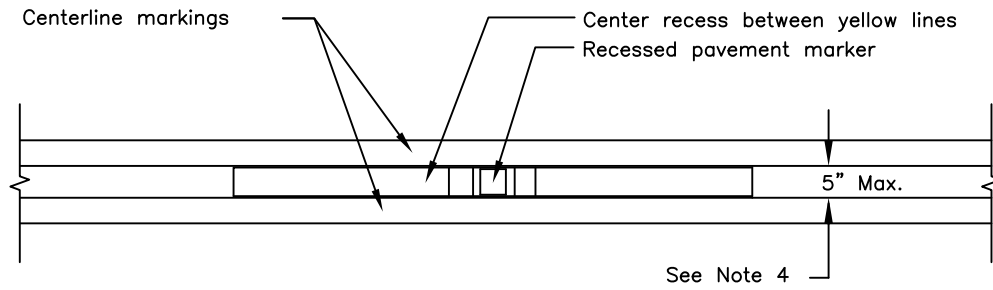

RECESSED PAVEMENT MARKERS WITH DOUBLE CENTERLINE INSTALLATION

GENERAL NOTES

1. Install recessed pavement markers spaced at 80' on tangent sections of roadway and on curves with a radius greater than 1,600'.
2. Install recessed pavement markers spaced at 40' on curves with a radius 1,600' or less.
3. Install recessed pavement markers between the lines on sections with double lines (either broken or solid.)
4. Increase the distance between yellow painted lines from the standard 3" up to a maximum of 5" to minimize paint overspray onto the marker.
5. Install recessed pavement markers on the centerline of the line, midpoint between stripe segments on sections with single broken lines.
6. Install reflectors of the same color as the pavement markings they supplement, except when red reflectors are specified on the departure side of markers on one-way roads to warn motorists they are going the wrong way.
7. Unless otherwise specified on one-way roads, reflectors are required only on the approaching traffic side of markers. In these cases, the 2'-6" taper may be omitted on the departure side.

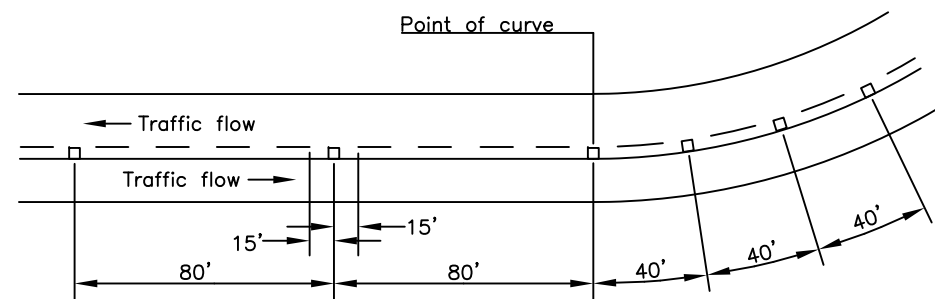

RECESSED PAVEMENT MARKERS ON CURVES WITH A RADIUS LESS THAN 1,600'

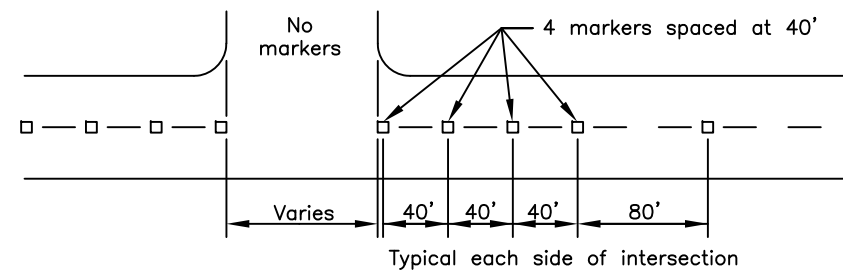

RECESSED PAVEMENT MARKERS AT INTERSECTION APPROACHES

State of Alaska DOT&PF
ALASKA STANDARD PLAN
RECESSED PAVEMENT
MARKERS

Adopted as an Alaska
Standard Plan by: *Kenneth J. Fisher*
Kenneth J. Fisher, P.E.
Chief Engineer

Adoption Date: 02/08/2019

Last Code and Stds. Review
By: Date:

Next Code and Standards Review date: 02/08/2029

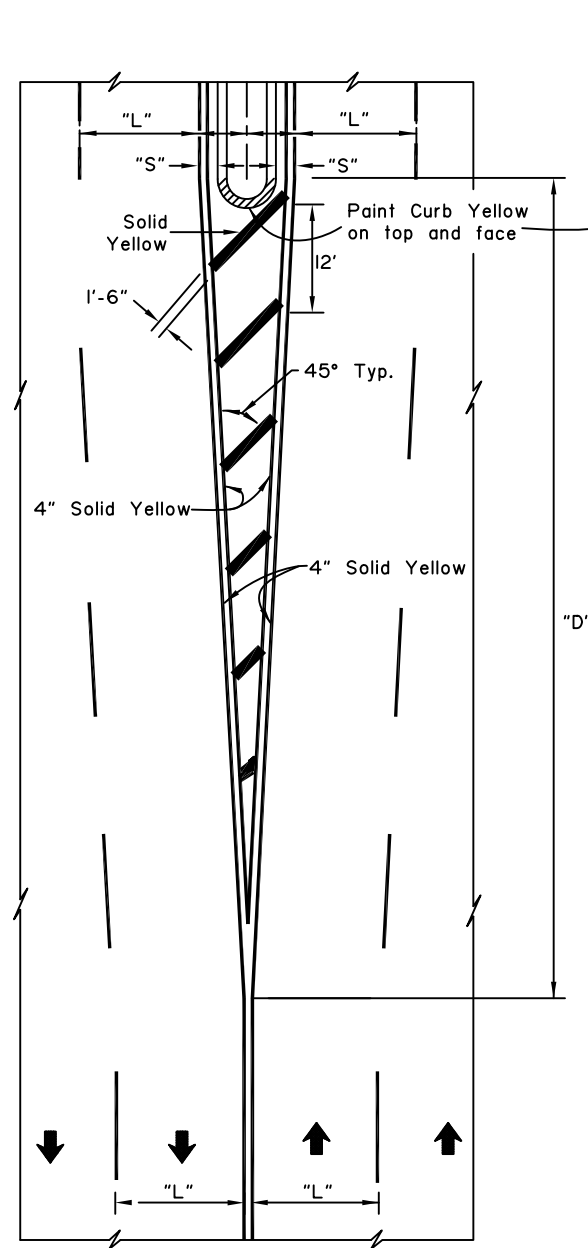

FOUR OR MORE LANES
— DRIVE TO RIGHT —

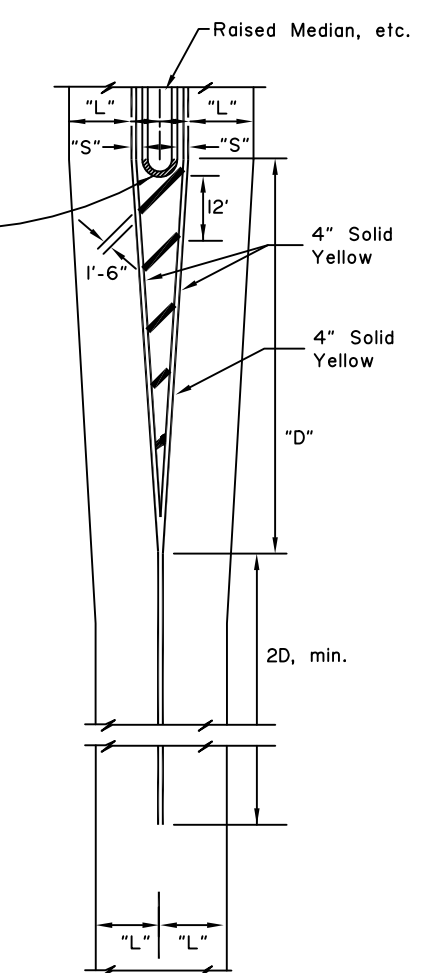

TWO LANES
— DRIVE TO RIGHT —
White longitudinal and diagonal markers identical to Four Lane Arrangement.

NOTES: "D" = Speed limit (mph) X "S" (offset width in feet) or as indicated on the plans. Minimum "D" = 100 feet urban, 200 feet rural.

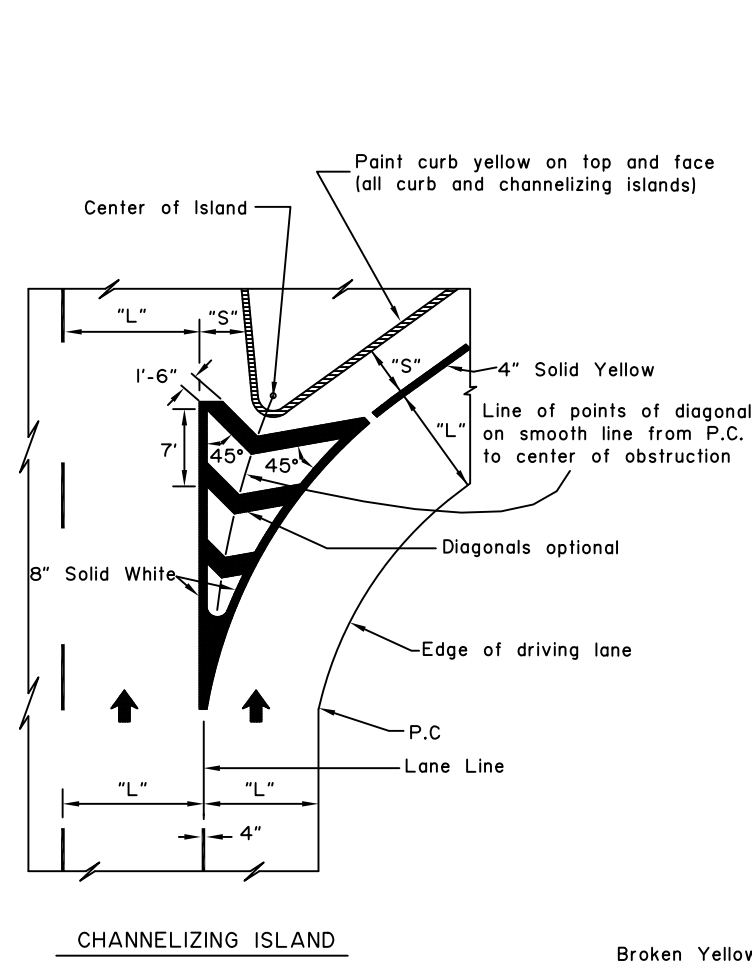

CHANNELIZING ISLAND

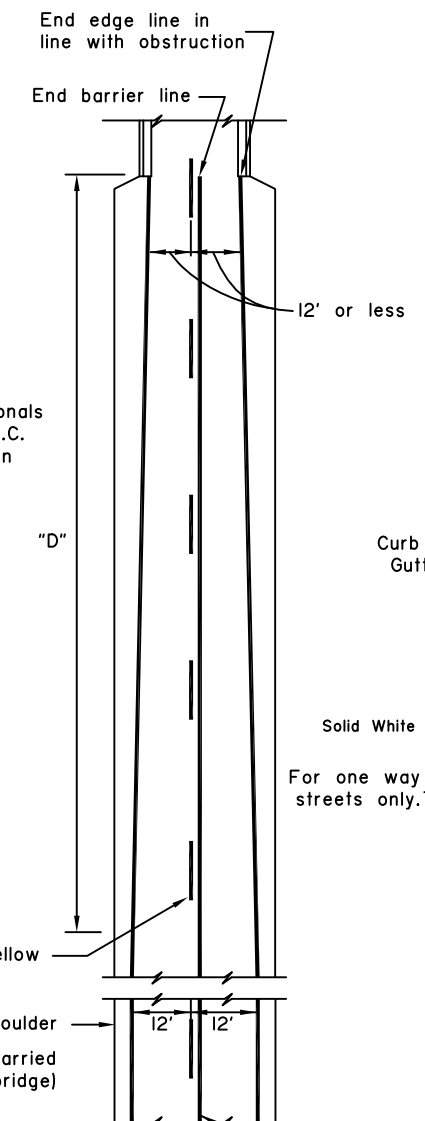

EDGE LINE TRANSITION TO NARROW BRIDGE AND APPROACH BARRIER LINE

4" Solid yellow barrier line (500 foot length)
Note: On bridges over 24' wide use standard pavement markings. Barrier lines not used unless otherwise required.

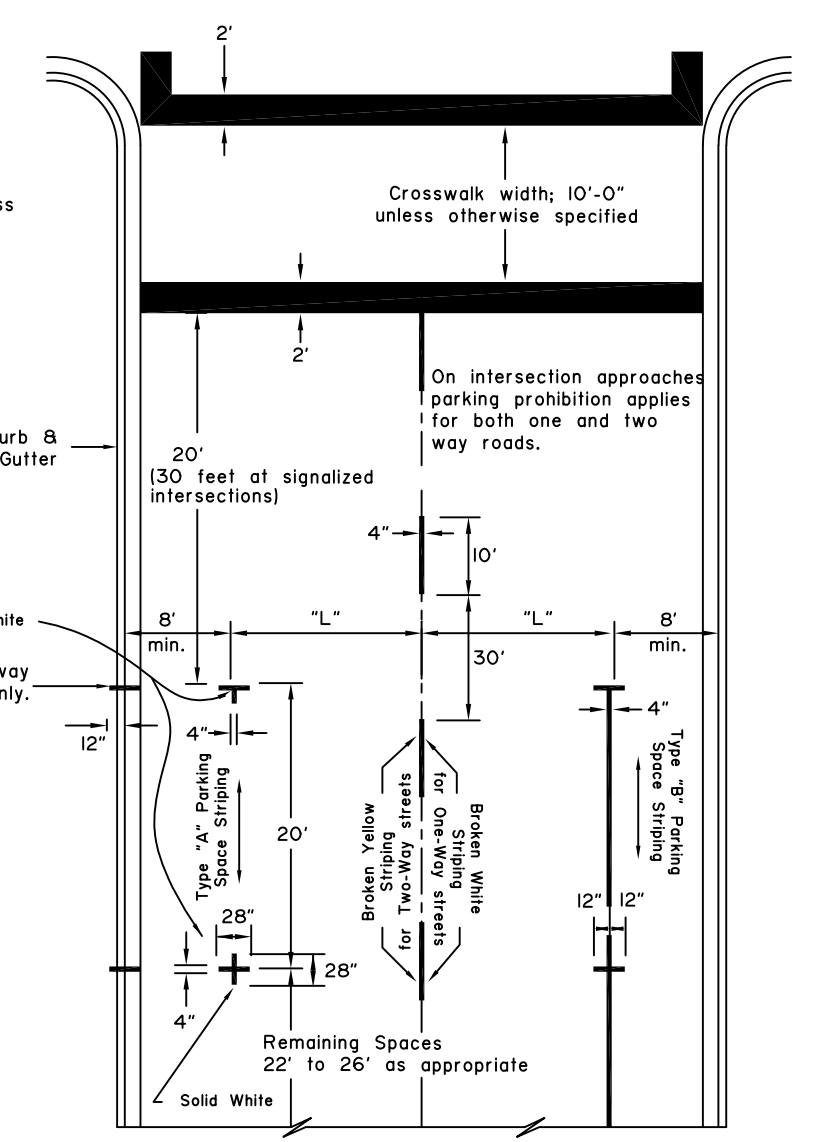

CENTERLINES FOR TWO LANE TWO WAY URBAN ROADS-PARKING LIMIT LINES

RAILROAD CROSSING NOTES:

- All markings solid white unless indicated otherwise.
- On 4-lane roadways place railroad crossing approach markings in each lane of the approach.
- Locate Stop Bar 15' from railroad track or 8' from gate, if present.
- Place edge lines and lane lines on a uni-directional approach in a normal manner except that the lane line(s) shall be solid 4" white in lieu of broken for a distance of (D+60') in advance of the stop bands.

POSTED LIMIT	D
30 M.P.H.	225'
40	350'
50	475'
60	625'

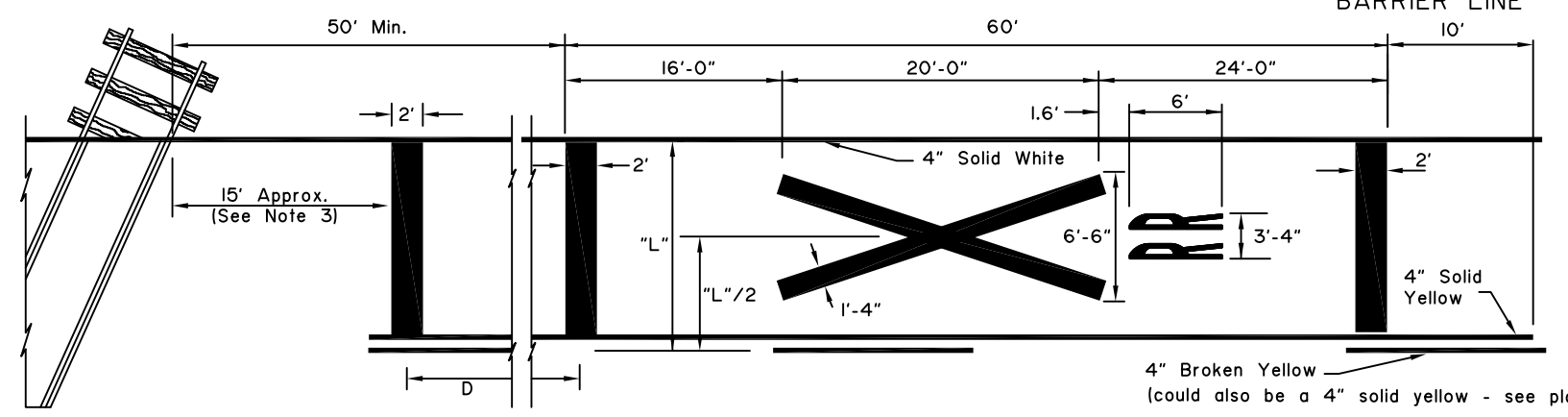

APPROACH TO RAILROAD CROSSING ON 2 LANE 2 WAY HIGHWAY

GENERAL NOTES:

- "S" = offset distance as shown on the plans, otherwise 1 to 2 feet.
- "L" = driving lane width.
- See the Alaska Traffic Manual for additional guidance and/or restrictions on the use of traffic control devices.

NOT TO SCALE

State of Alaska DOT&PF
ALASKA STANDARD PLAN
PAVEMENT MAKING APPLICATIONS

Adopted as an Alaska Standard Plan by: *Kenneth J. Fisher*
Kenneth J. Fisher, P.E.
Chief Engineer

Adoption Date: 02/08/2019

Last Code and Stds. Review By: _____ Date: _____
Next Code and Standards Review date: 02/08/2029

GENERAL NOTES:

1. All markings white unless indicated otherwise.
2. Lengths of stripe and gap for lane and center lines identical.
3. Lane lines for auxiliary lanes are unbroken solid lines.
4. "L" = driving lane width.
5. "S" = shy distance as shown on plans, otherwise 1 to 2 feet.
6. ONLY markings are required where through lanes change to turn lanes. In other cases, apply ONLY markings as indicated on plans.
7. See ALASKA TRAFFIC MANUAL for additional instruction on the use of TRAFFIC CONTROL DEVICES.
8. Adjust distance D between ONLY and Turn Arrow based on SPEED vs. D table. Table may be used for spacing between pairs of TWLT markings.
9. Adjust centerline spacing from 3" up to 5" where recessed pavement markers are required.
10. Arrows and symbols are used for through lanes only when the lane layout deviates from the normal intersection rules, and shall only be used where indicated in the plans.

SPEED	D
25 or less	35'
30	45'
35	50'
40	60'
45	65'
50	75'
55 or more	80'

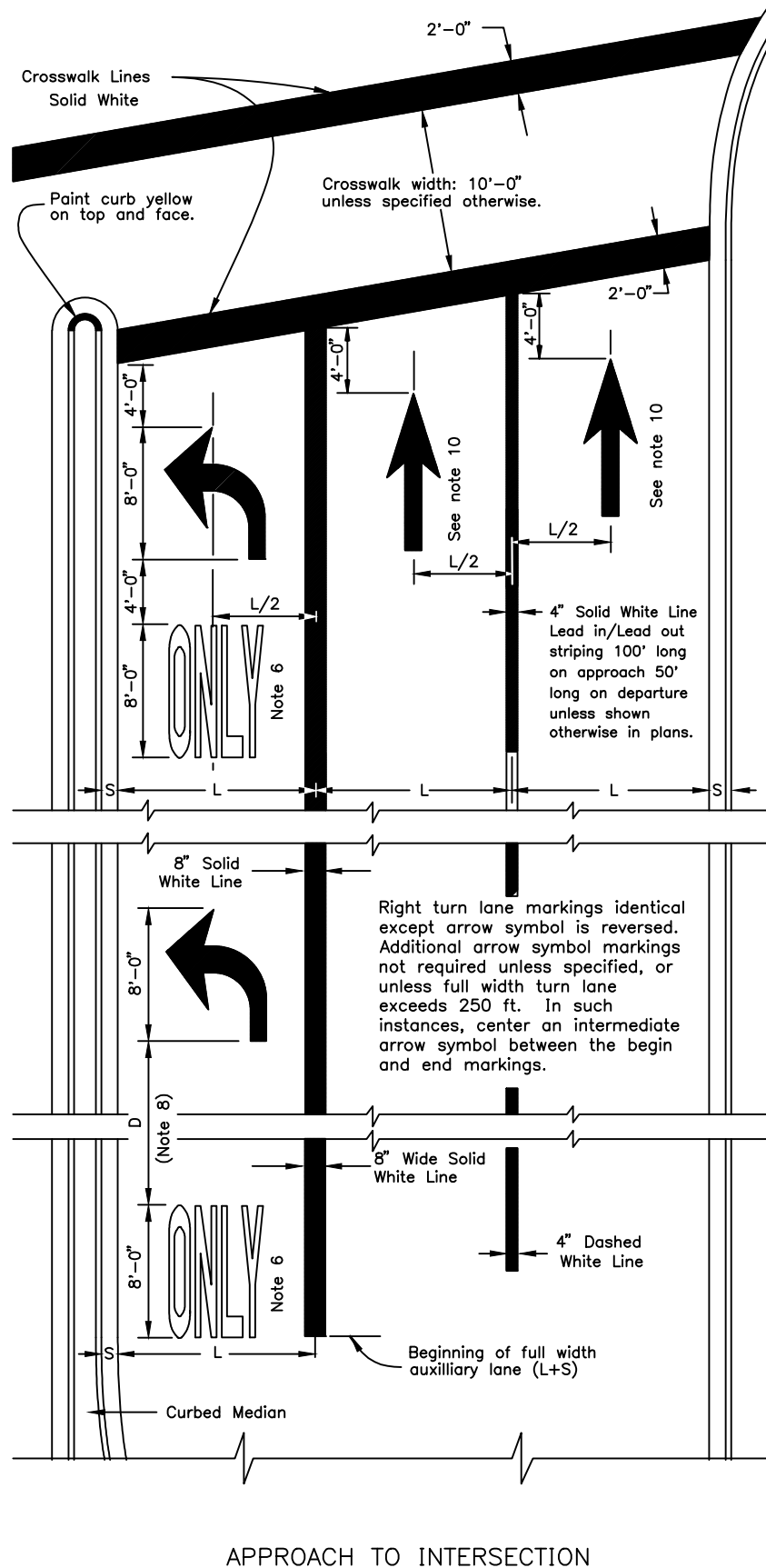

APPROACH TO INTERSECTION

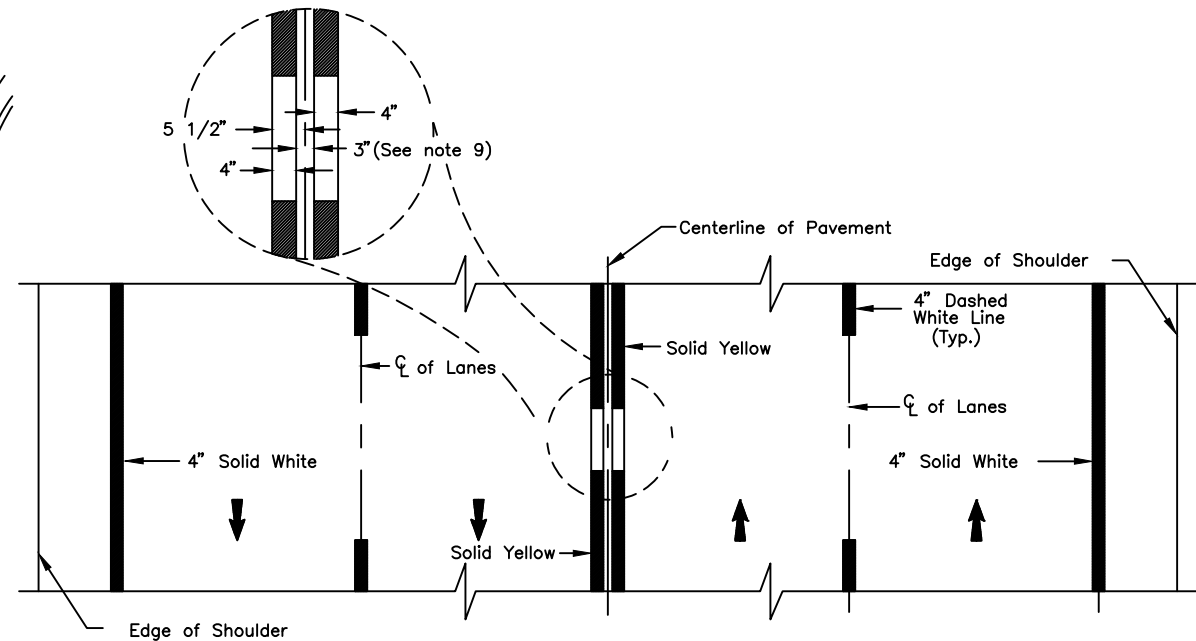

FOUR LANE TWO WAY

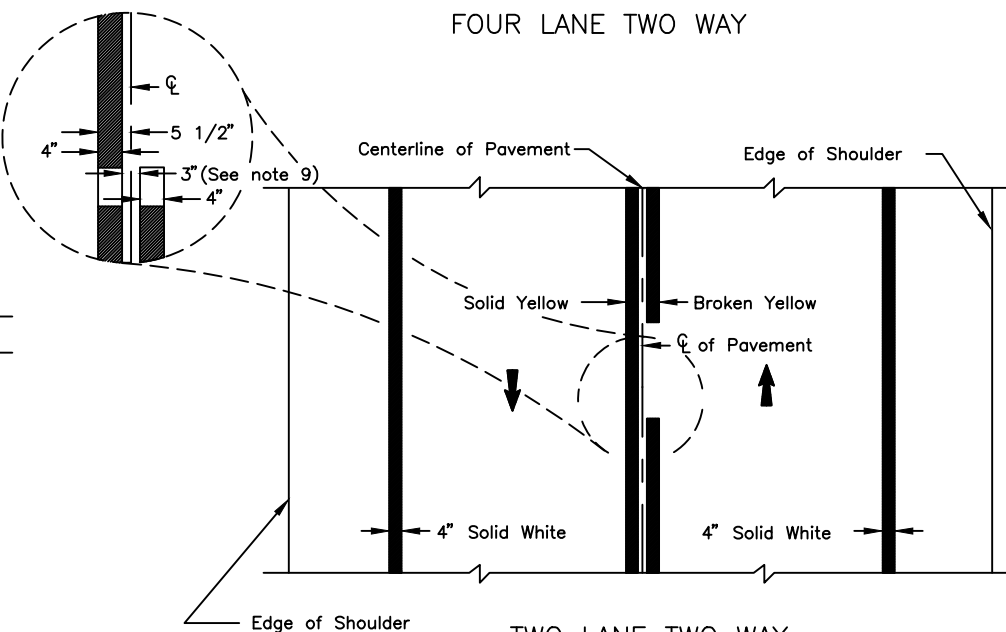

TWO LANE TWO WAY

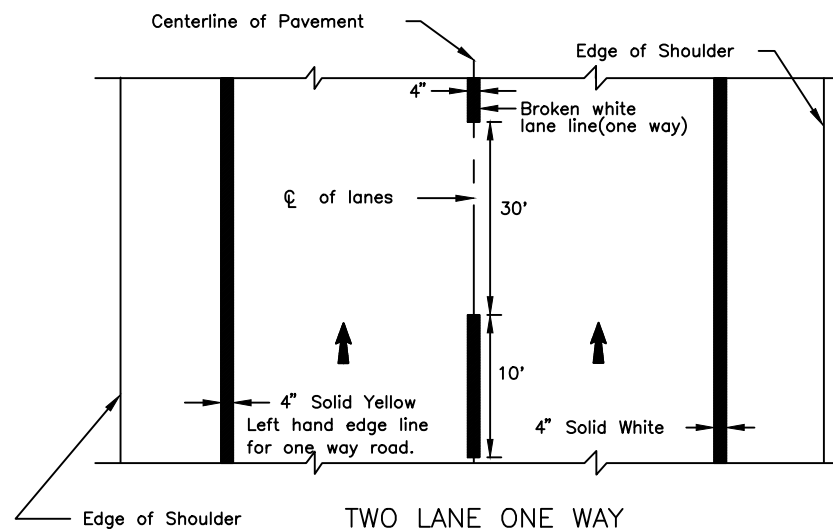

TWO LANE ONE WAY

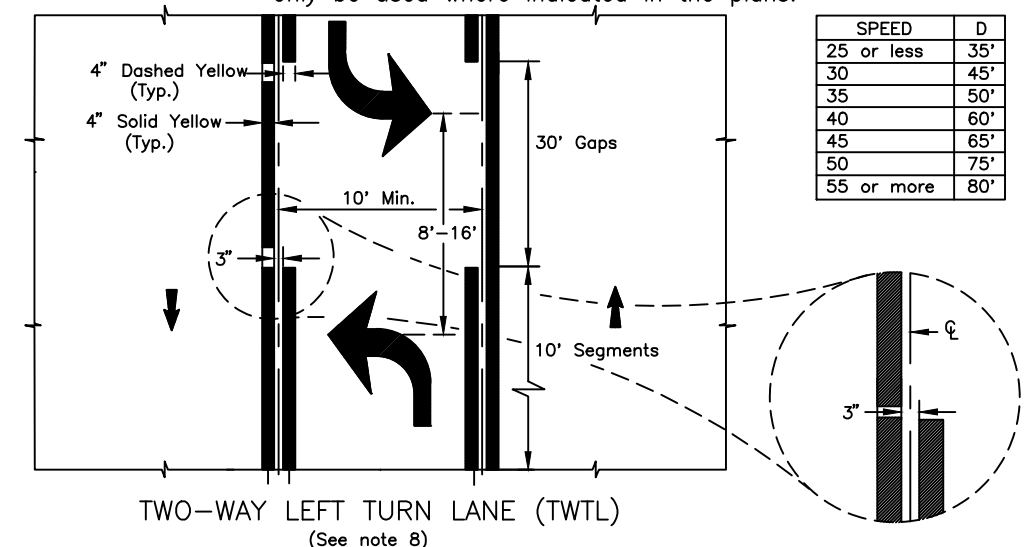

TWO-WAY LEFT TURN LANE (TWLT)
(See note 8)

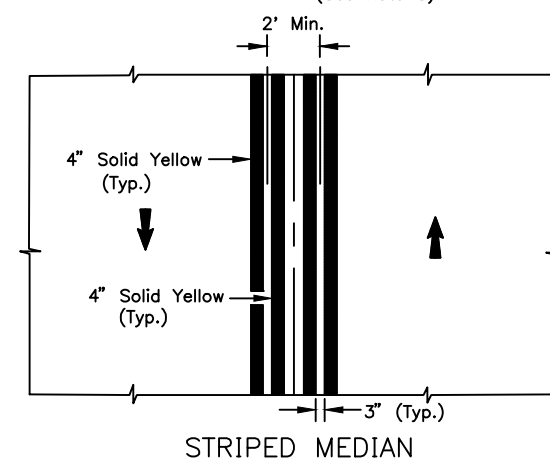

STRIPED MEDIAN

State of Alaska DOT&PF
ALASKA STANDARD PLAN

PAVEMENT MARKING
APPLICATIONS

Adopted as an Alaska Standard Plan by: *Carolyn Morehouse*
Carolyn Morehouse, P.E.
Chief Engineer

Adoption Date: 7/17/2020

Last Code and Stds. Review
By: KLK Date: 7/8/2020

Next Code and Standards Review Date: 7/8/2030

GENERAL NOTES:

1. All symbols shown shall be white and reflectorized in accordance with the Special Provisions.
2. See the Alaska Sign Design Specifications (ASDS) for lettering and symbols for pavement marking details not provided on this drawing.

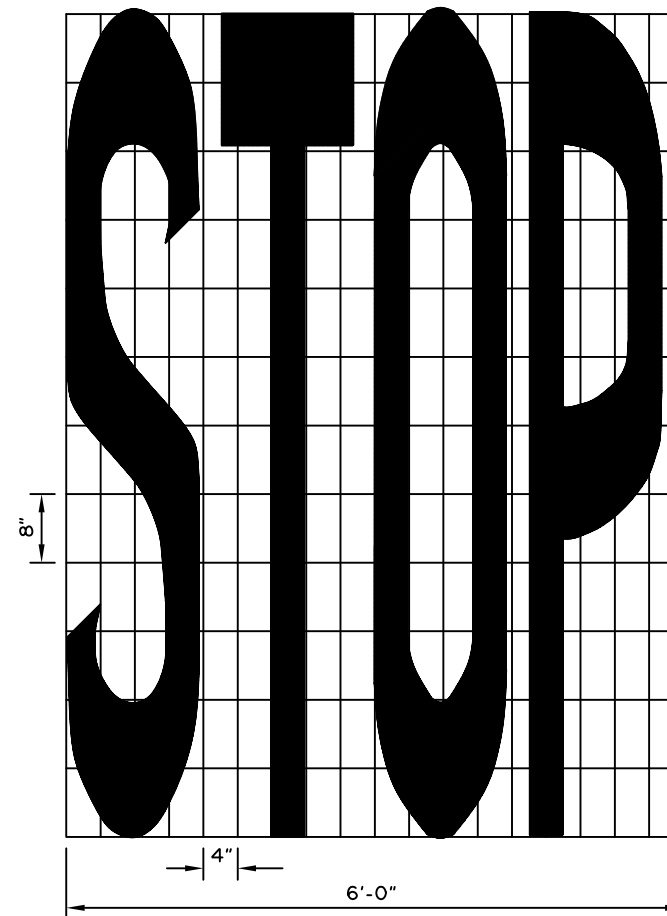
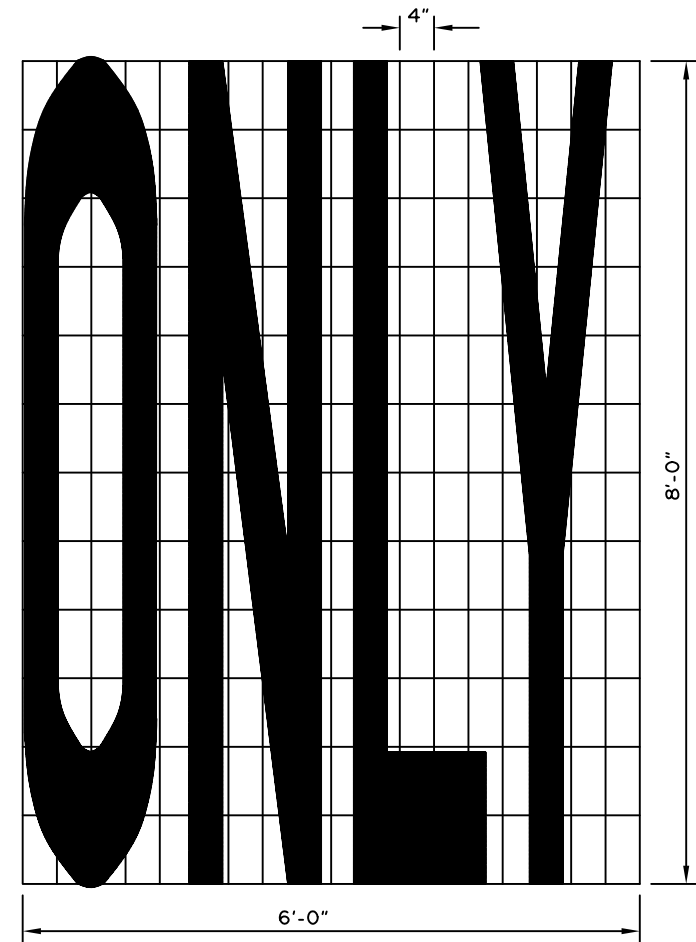
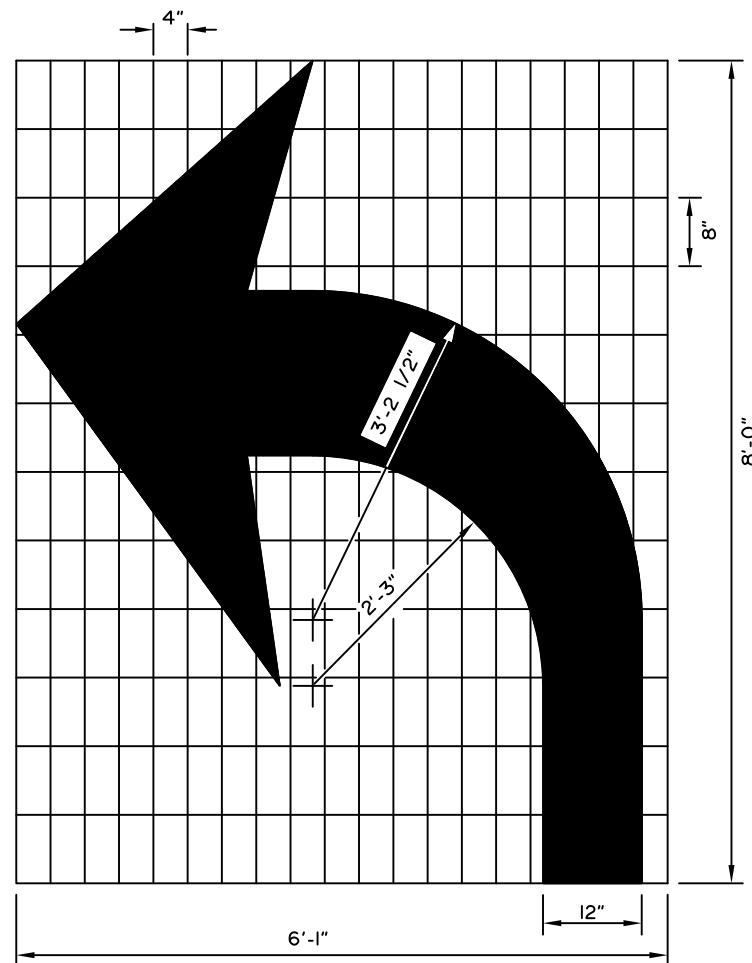

Right turn auxiliary lane usage markings identical except arrow symbol is reversed.

LAYOUT TEMPLATES FOR STENCILS

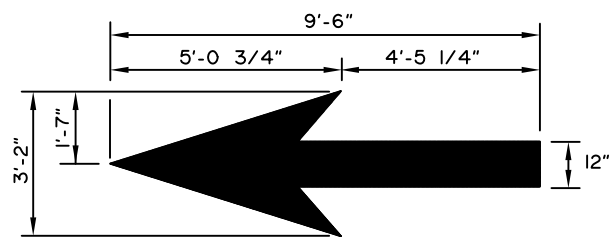

STRAIGHT AHEAD ARROW

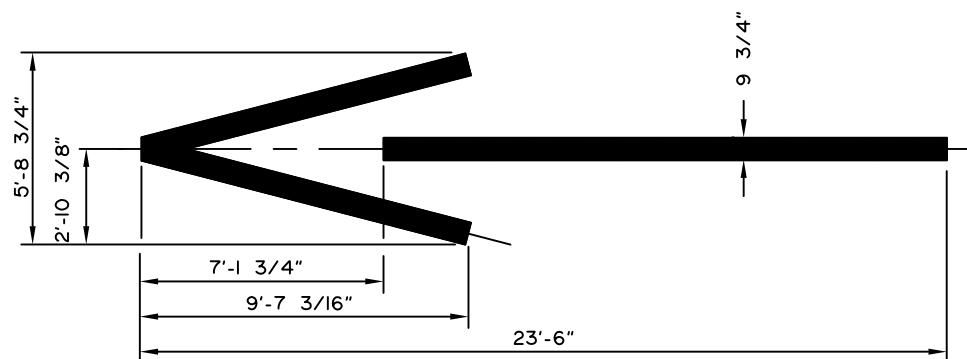

WRONG WAY ARROW

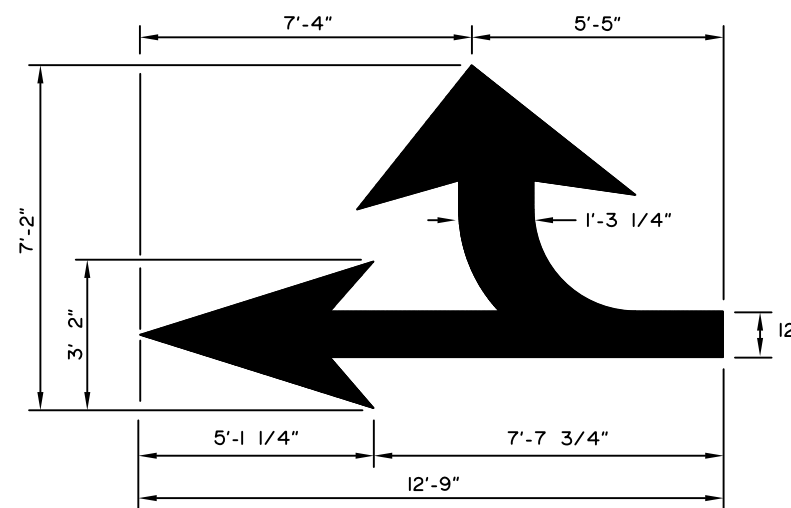

COMBINATION ARROW

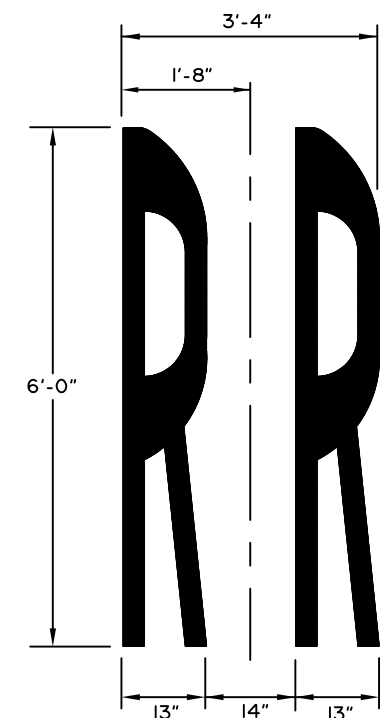

RAILROAD SYMBOL

State of Alaska DOT&PF
ALASKA STANDARD PLAN
PAVEMENT MARKING
SYMBOL DIMENSIONS

Adopted as an Alaska
Standard Plan by: *Kenneth J. Fisher*
Kenneth J. Fisher, P.E.
Chief Engineer

Adoption Date: 02/08/2019

Last Code and Stds. Review
By: Date:

Next Code and Standards Review date: 02/08/2029

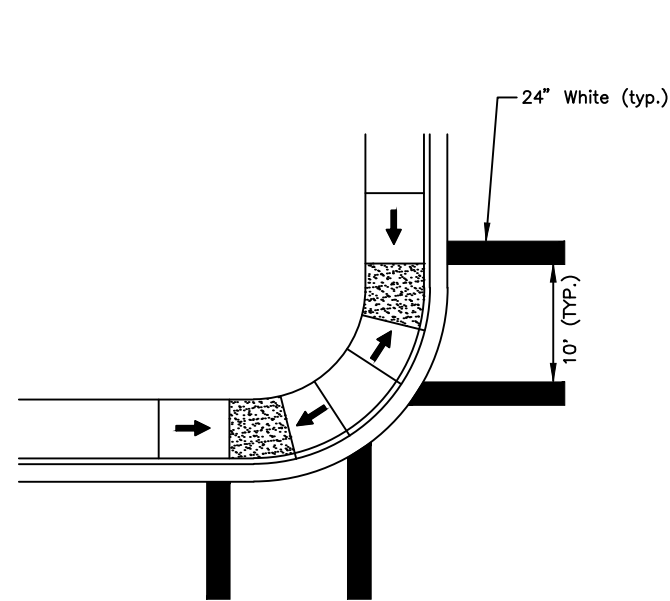

CASE 1

Dual Curb Ramps
Radius $\leq 25'$

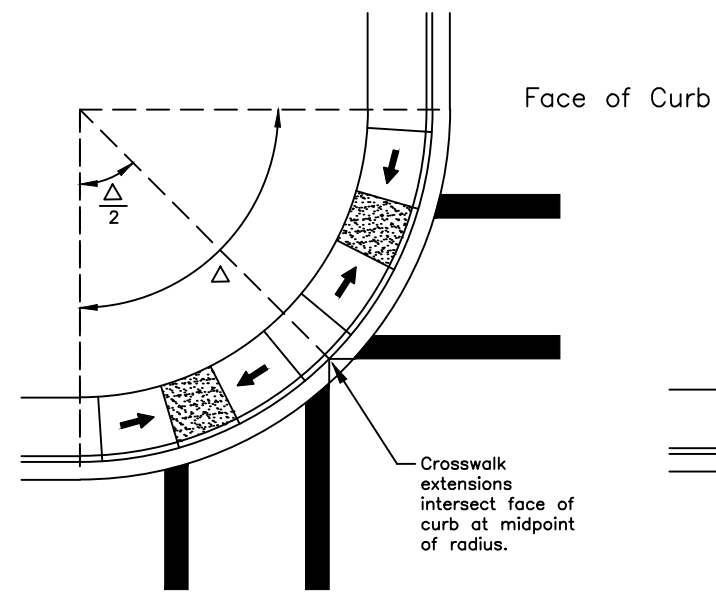

CASE 2

Dual Curb Ramps
 $25' < \text{Radius} \leq 50'$

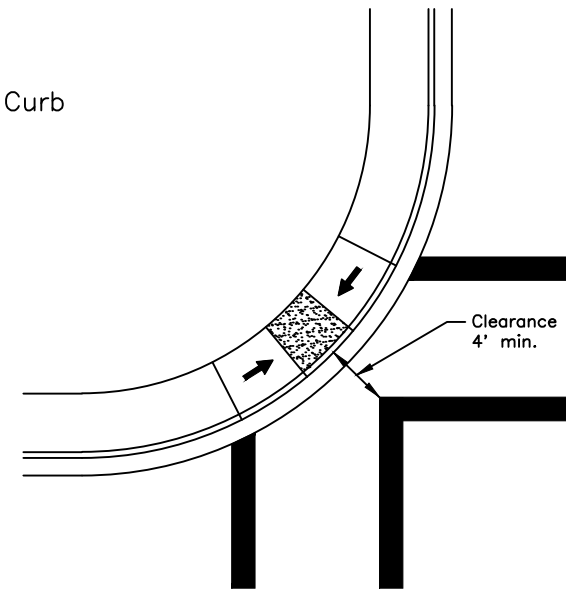

CASE 3

Single Central Curb Ramp
 $25' \leq \text{Radius} \leq 50'$
(Not Recommended)

GENERAL NOTES

1. The crosswalk locations shown assume a 90-degree intersection – adjust as necessary on skewed intersections to ensure that crosswalk landings (for parallel curb ramps) or ramp runs (for perpendicular curb ramps) fall within the inner edges of crosswalk stripes. If Case 3 (not recommended) is used, the layout should also be adjusted to provide at least the minimum clearance while maximizing the offset.
2. If only one crosswalk connects with a curb radius, it should be located as if there were two connecting crosswalks.
3. These details apply to parallel (shown) as well as perpendicular curb ramps.
4. Case 3, the layout for a single central curb ramp, should be used only when installing two ramps is not feasible. It should not be used for radii under 25 feet. See plans for ramp layout at particular locations.
5. Radius is measured to the face of curb.

State of Alaska DOT&PF
ALASKA STANDARD PLAN

CROSSWALK LOCATION AT
SIGNALIZED INTERSECTIONS

Adopted as an Alaska
Standard Plan by: *Carolyn Morehouse*
Carolyn Morehouse, P.E.
Chief Engineer

Adoption Date: 7/17/2020

Last Code and Stds. Review
By: KLK Date: 7/8/2020

Next Code and Standards Review Date: 7/8/2030

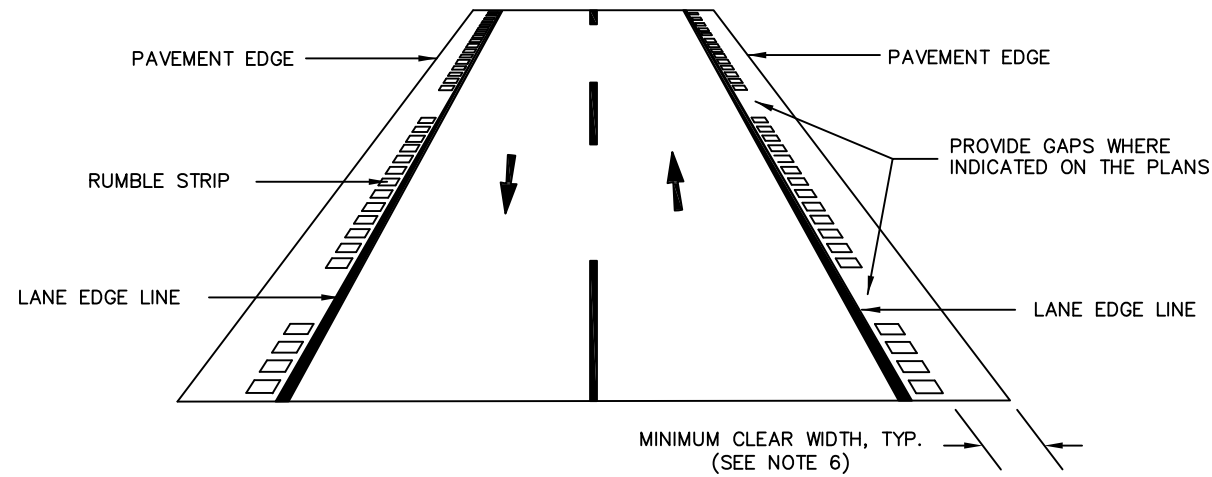

TYPICAL SHOULDER INSTALLATION – TWO-WAY
PERSPECTIVE VIEW

APPLIES TO TWO-WAY OPERATION
WHERE BICYCLES ARE ALLOWED

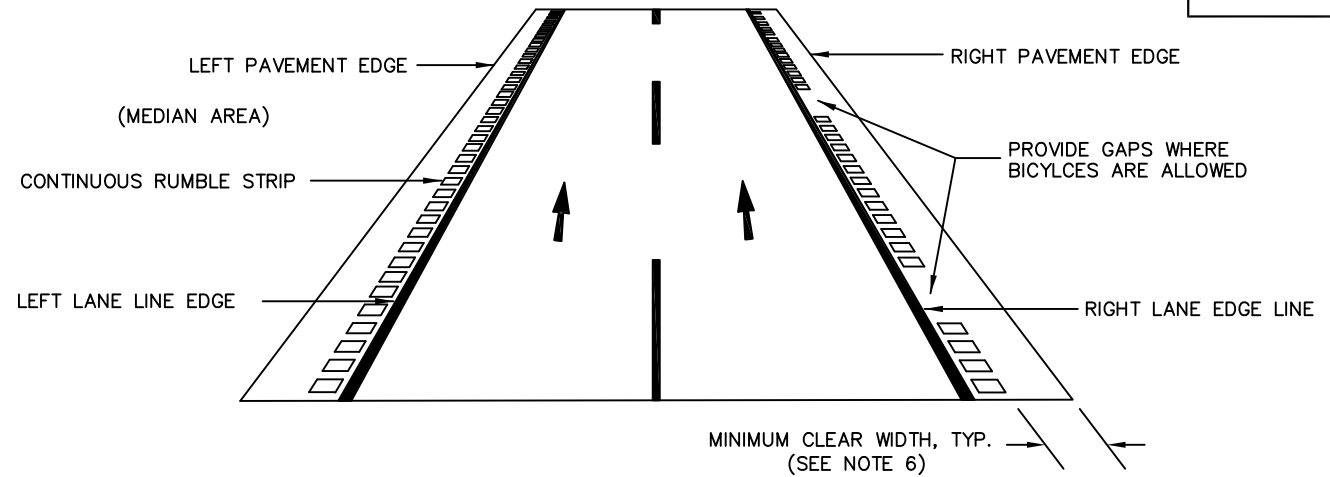

TYPICAL SHOULDER INSTALLATION – ONE-WAY DIVIDED
PERSPECTIVE VIEW

APPLIES TO ONE-WAY DIVIDED HIGHWAYS
WHERE BICYCLES ARE ALLOWED

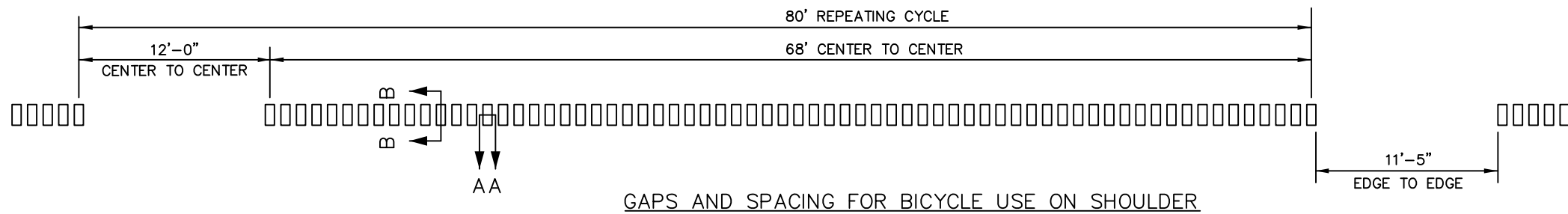

GAPS AND SPACING FOR BICYCLE USE ON SHOULDER

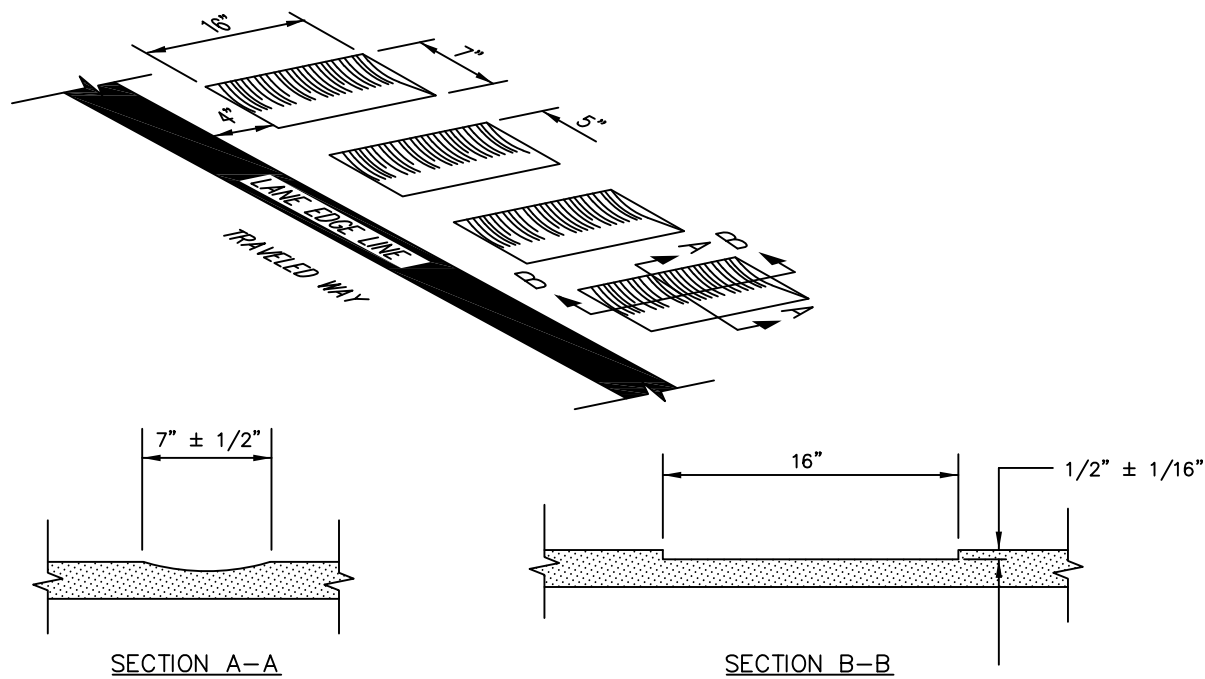

TYPICAL SHOULDER INSTALLATION DETAIL

SHOULDER RUMBLE STRIP NOTES:

1. PERFORM ALL STAKING AS NECESSARY TO INSTALL RUMBLE STRIPS IN ACCORDANCE WITH THE PLANS, THESE DETAILS, AND THE FOLLOWING NOTES:
2. DO NOT INSTALL RUMBLE STRIPS IN THE FOLLOWING INSTANCES:
 - A. BRIDGE DECKS
 - B. BRIDGE APPROACH SLABS
 - C. PAVEMENT LESS THAN 2 INCHES THICK
 - D. PAVEMENT THAT HAS ALLIGATORING, FATIGUE, CRACKING, OR IN POOR CONDITION
 - E. PAVEMENT JOINTS
 - F. INTO LANE EDGE LINE STRIPING
3. USE CENTERLINE OR LANE LINE DIVIDING LINES, RATHER THAN LANE EDGE LINES, FOR RUMBLE STRIP ALIGNMENT CONTROL WHENEVER POSSIBLE.
4. WHERE BICYCLES ARE ALLOWED ON THE FACILITY, SHOULDER RUMBLE STRIP GAPS (68' RUMBLE STRIP, 12' GAP CENTER TO CENTER, 11'-5" GAP, EDGE TO EDGE) SHOULD BE CONTINUOUS.
5. ON DIVIDED HIGHWAYS, PROVIDE CONTINUOUS RUMBLE STRIP ON THE INSIDE (LEFT) SHOULDER.
6. MINIMUM REQUIRED CLEAR WIDTHS AFTER INSTALLATION ARE AS FOLLOWS:
 - A. AT LEAST 4' WHERE NO GUARDRAIL IS PRESENT (6.0' INITIAL SHOULDER WIDTH).
 - B. AT LEAST 5' (TO FACE OF GUARDRAIL) WHERE GUARDRAIL IS PRESENT (≥ 7.0' AT INITIAL SHOULDER WIDTH).
 - C. NO MINIMUM WHERE BICYCLES ARE PROHIBITED.

Note: Drawing not to scale

State of Alaska DOT&PF
ALASKA STANDARD PLAN
**MILLED RUMBLE STRIPS
SHOULDER DETAILS**

Adopted as an Alaska Standard Plan by: *Carolyn Morehouse*
Carolyn Morehouse, P.E.
Chief Engineer

Adoption Date: 07/17/2020

Last Code and Stds. Review
By: LRG Date: 07/17/2020
Next Code and Standards Review date: 07/17/2030

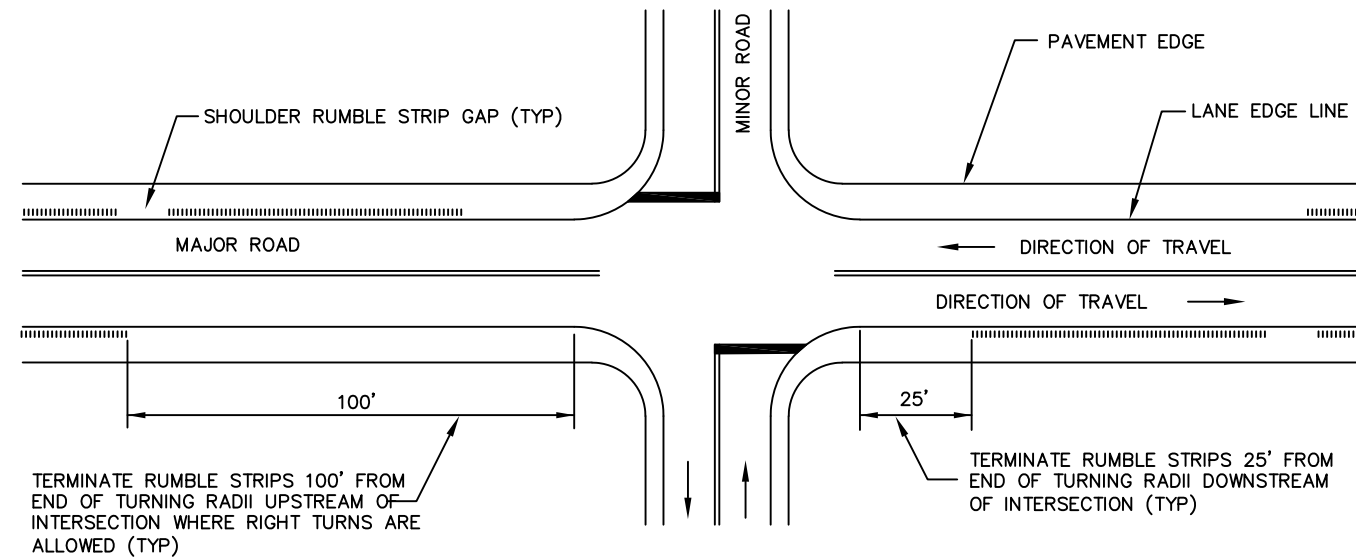

RUMBLE STRIP LAYOUT AT INTERSECTIONS

APPLIES TO ALL SIDE ROAD INTERSECTIONS, PUBLIC TURNOUTS, COMMERCIAL ROAD APPROACHES, AND GANG MAILBOX TURNOUTS (WHERE BICYCLES ARE ALLOWED)

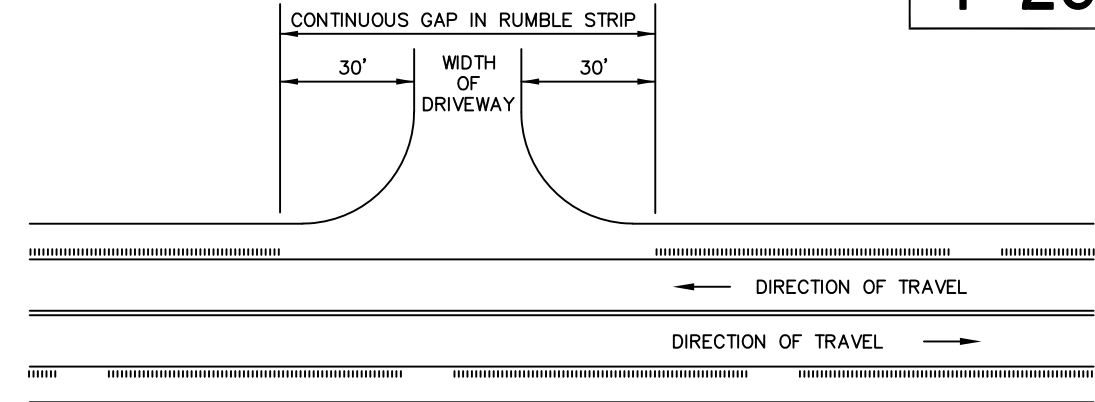

RUMBLE STRIP LAYOUT AT RESIDENTIAL DRIVEWAYS

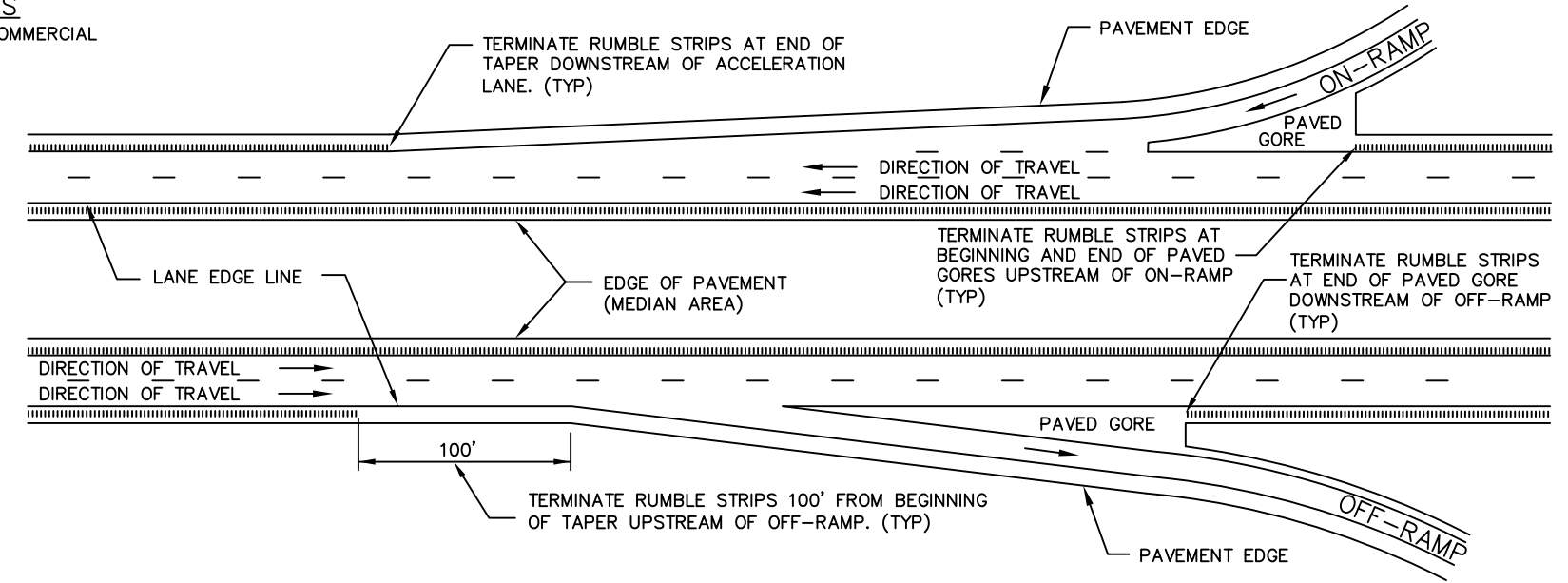

RUMBLE STRIP LAYOUT AT FREEWAY ON- AND OFF-RAMPS

THIS DRAWING APPLIES TO BOTH PARALLEL AND TAPERED LANES (WHERE BICYCLES ARE ALLOWED)

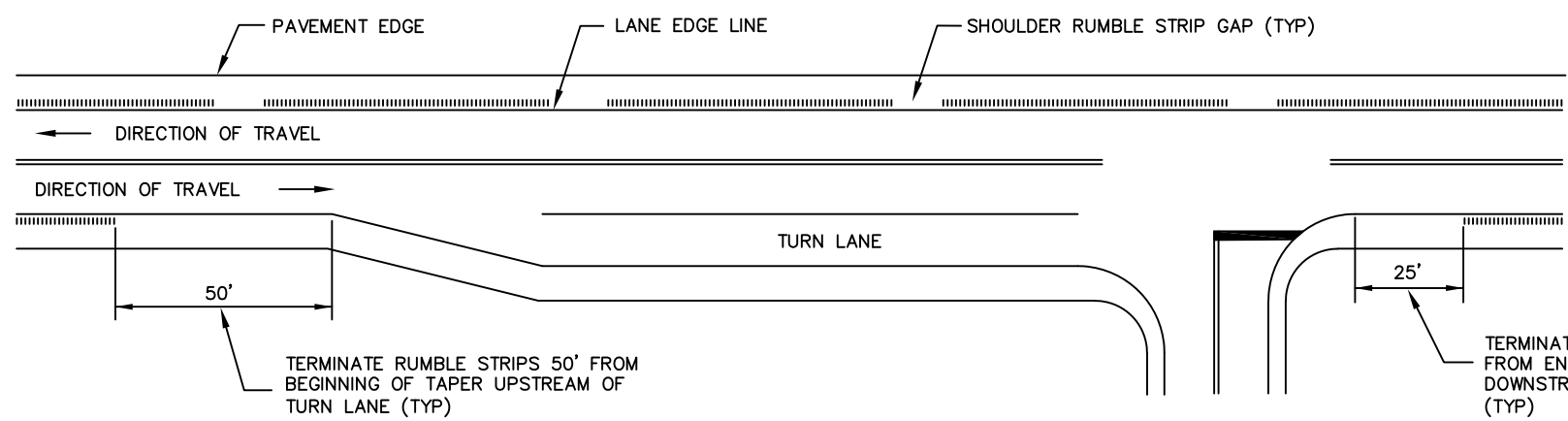

RUMBLE STRIP LAYOUT AT RIGHT TURN LANES

(WHERE BICYCLES ALLOWED)

Note: Drawing not to scale

State of Alaska DOT&PF
ALASKA STANDARD PLAN
**MILLED RUMBLE STRIPS
SHOULDER DETAILS**

Adopted as an Alaska Standard Plan by: *Carolyn Morehouse*
Carolyn Morehouse, P.E.
Chief Engineer

Adoption Date: 07/17/2020

Last Code and Stds. Review
By: LRG Date: 07/17/2020
Next Code and Standards Review date: 07/17/2030

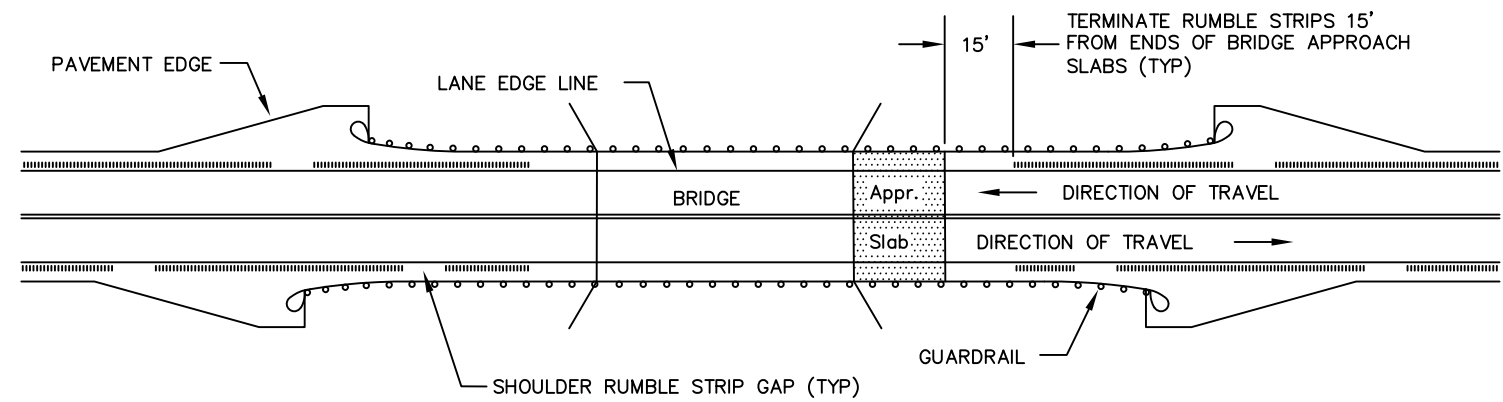

RUMBLE STRIP LAYOUT AT BRIDGES WITH ADEQUATE SHOULDER
(WHERE BICYCLES ARE ALLOWED)

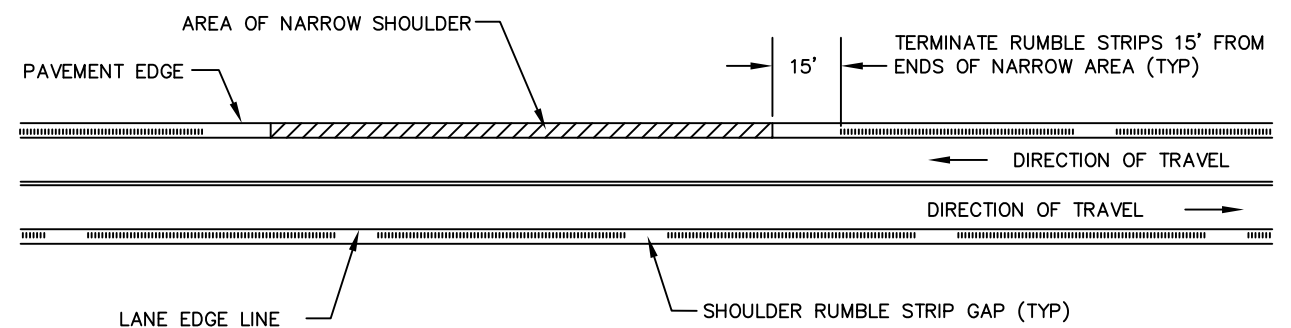

RUMBLE STRIP LAYOUT IN AREAS WITH NARROW SHOULDER
(WHERE BICYCLES ARE ALLOWED)
(SEE NARROW SHOULDER WIDTH NOTE THIS SHEET FOR DEFINITIONS AND TOLERANCES)

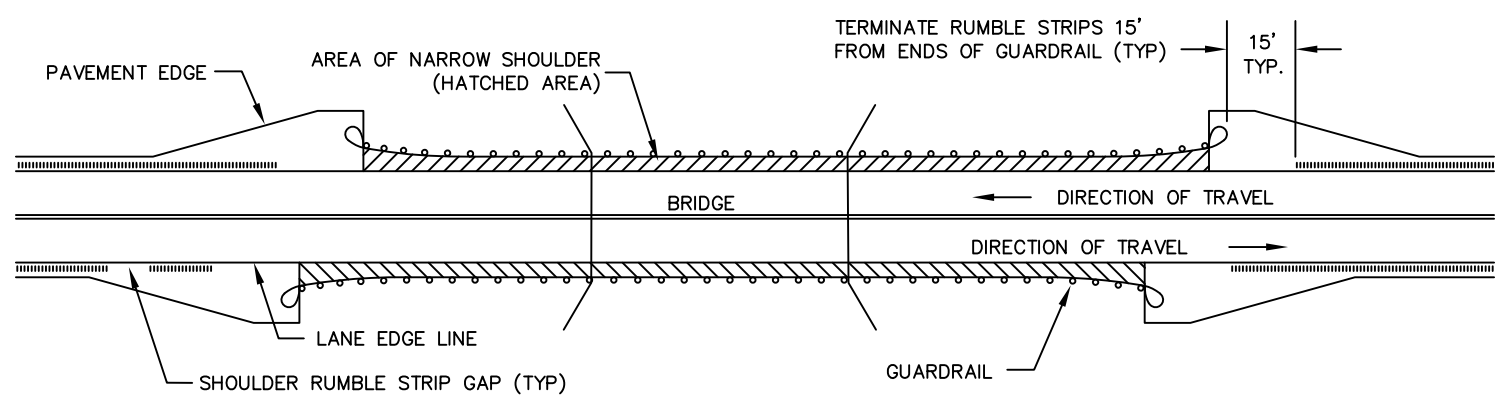

RUMBLE STRIP LAYOUT AT BRIDGES WITH NARROW SHOULDER
(WHERE BICYCLES ARE ALLOWED)
(SEE NARROW SHOULDER WIDTH NOTES THIS SHEET)

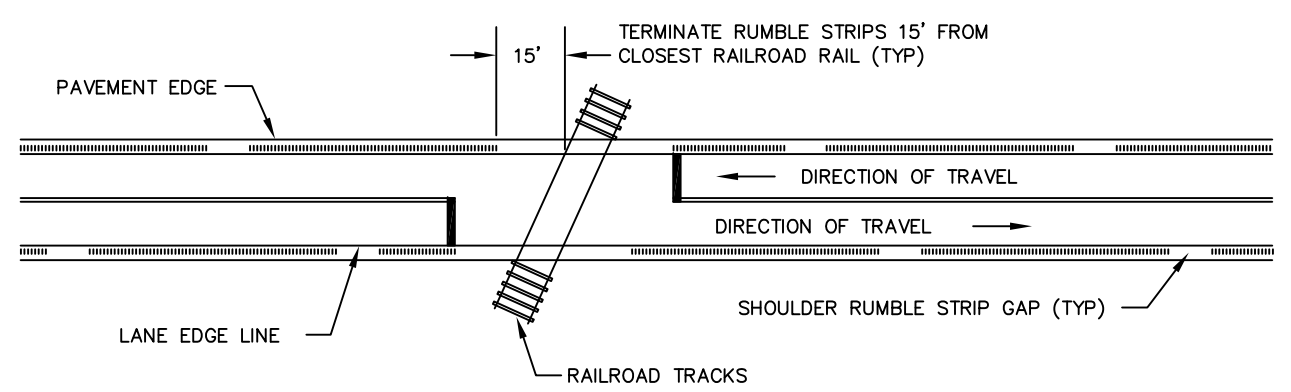

RUMBLE STRIP LAYOUT AT RAILROAD CROSSINGS
(WHERE BICYCLES ARE ALLOWED)

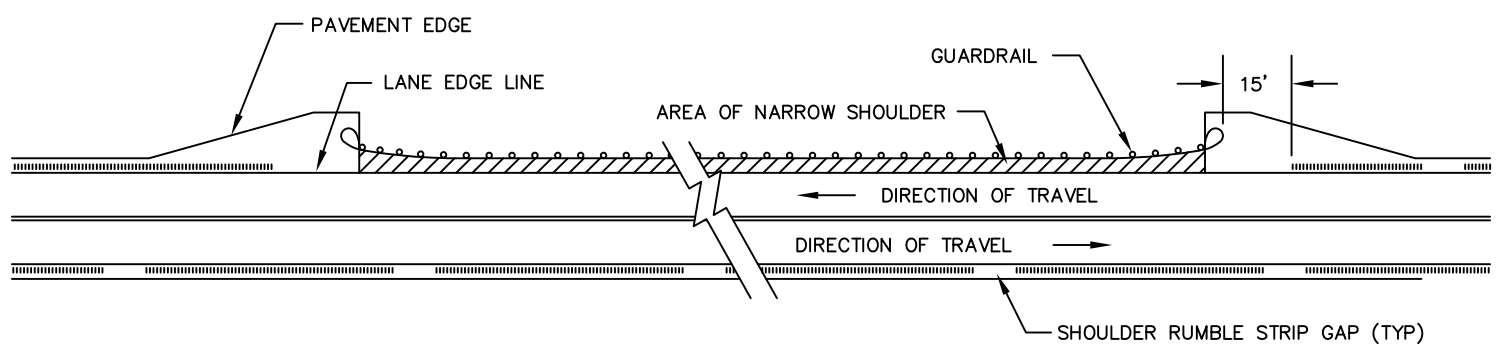

RUMBLE STRIP LAYOUT IN AREAS WITH GUARDRAIL AND NARROW SHOULDER
(WHERE BICYCLES ARE ALLOWED)
(SEE NARROW SHOULDER WIDTH NOTES THIS SHEET)

NARROW SHOULDER WIDTH NOTES:

A SIX INCH TOLERANCE IS ALLOWED (FOR DISTANCES OF 100 FT. OR LESS) FOR THE FOLLOWING MINIMUM REQUIRED CLEAR WIDTHS:

- a. AT LEAST 4' WHERE NO GUARDRAIL IS PRESENT.
- b. AT LEAST 5' (TO FACE OF GUARDRAIL) WHERE GUARDRAIL IS PRESENT.
- c. NO MINIMUM WHERE BICYCLES ARE PROHIBITED.

Note: Drawing not to scale

State of Alaska DOT&PF
ALASKA STANDARD PLAN
MILLED RUMBLE STRIPS
SHOULDER DETAILS

Adopted as an Alaska Standard Plan by: *Carolyn Morehouse*
Carolyn Morehouse, P.E.
Chief Engineer

Adoption Date: 07/17/2020

Last Code and Sds. Review
By: LRG Date: 07/17/2020

Next Code and Standards Review date: 07/17/2030

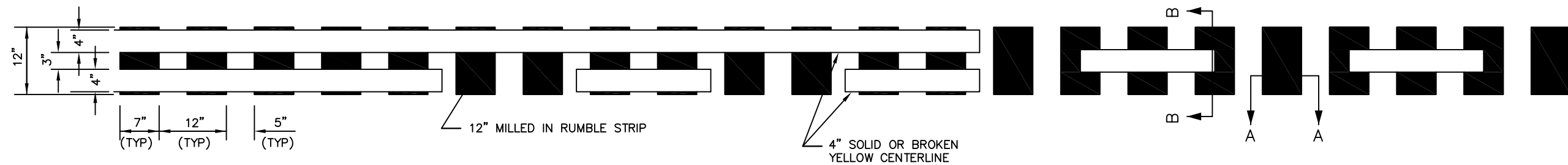

CENTERLINE RUMBLE STRIP PLAN VIEW

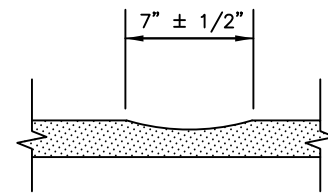

SECTION A-A

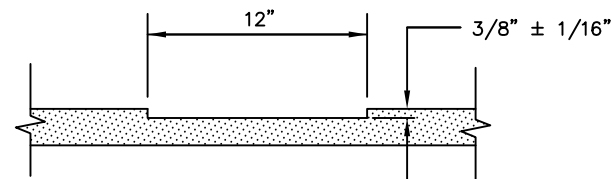

SECTION B-B

CENTERLINE RUMBLE STRIP NOTES:

1. PERFORM ALL STAKING AS NECESSARY TO INSTALL RUMBLE STRIPS IN ACCORDANCE WITH THE PLANS, THESE DETAILS, AND THE FOLLOWING NOTES.
2. DO NOT INSTALL RUMBLE STRIPS IN THE FOLLOWING INSTANCES:
 - A. BRIDGE DECKS
 - B. BRIDGE APPROACH SLABS
 - C. PAVEMENT LESS THAN 2 INCHES THICK
 - D. PAVEMENT THAT HAS ALLIGATORING, FATIGUE, CRACKING, OR IN POOR CONDITION
 - E. PAVEMENT JOINTS
 - F. INTO LANE EDGE LINE STRIPING
3. WHERE INSTALLED, CENTERLINE RUMBLE STRIPS SHALL BE CONTINUOUS REGARDLESS OF CENTERLINE STRIPING CONFIGURATION. BOTH PASSING AND NO-PASSING PORTIONS OF ROADWAY WITHIN THE LIMITS OF THE CENTERLINE RUMBLE STRIP INSTALLATION SHALL BE MILLED.
4. CENTERLINE RUMBLES MAY BE EXTENDED INTO PAINTED MEDIANS WHERE A DOUBLE YELLOW STRIPE SEPARATES OPPOSING TRAFFIC. WHERE CENTERLINES SPLIT TO CREATE A LEFT TURN LANE ALONG A RURAL HIGHWAY, THE RUMBLES SHOULD BE PLACED ALONG BOTH PORTIONS OF THE CENTERLINE.
5. DO NOT INSTALL CENTERLINE RUMBLE STRIPS IN A TWO-WAY LEFT TURN LANE.
6. DO NOT INSTALL CENTERLINE RUMBLES WHEN THE COMBINED LANE AND SHOULDER WIDTH IN EACH DIRECTION IS LESS THAN 14'.
7. BREAK CENTERLINE RUMBLES FOR ALL SIDE STREET AND COMMERCIAL ROAD INTERSECTIONS WHERE THERE ARE LEFT TURN LANES.
8. CENTERLINE STRIPING SHALL BE RE-ESTABLISHED FOLLOWING MILLING OPERATIONS IN ACCORDANCE WITH SECTION 670, "TRAFFIC MARKINGS". 60 MIL SURFACE APPLIED METHYL METHACRYLATE PAVEMENT MARKINGS SHALL BE INSTALLED ON ALL AREAS FOLLOWING CENTERLINE RUMBLE STRIP INSTALLATION WHERE CENTERLINE RUMBLE STRIPS ARE APPLIED.

Note: Drawing not to scale

State of Alaska DOT&PF
ALASKA STANDARD PLAN
MILLED RUMBLE STRIPS
CENTERLINE DETAILS

Adopted as an Alaska Standard Plan by: *Carolyn Morehouse*
Carolyn Morehouse, P.E.
Chief Engineer

Adoption Date: 07/17/2020

Last Code and Stds. Review
By: LRG Date: 07/17/2020

Next Code and Standards Review date: 07/17/2030

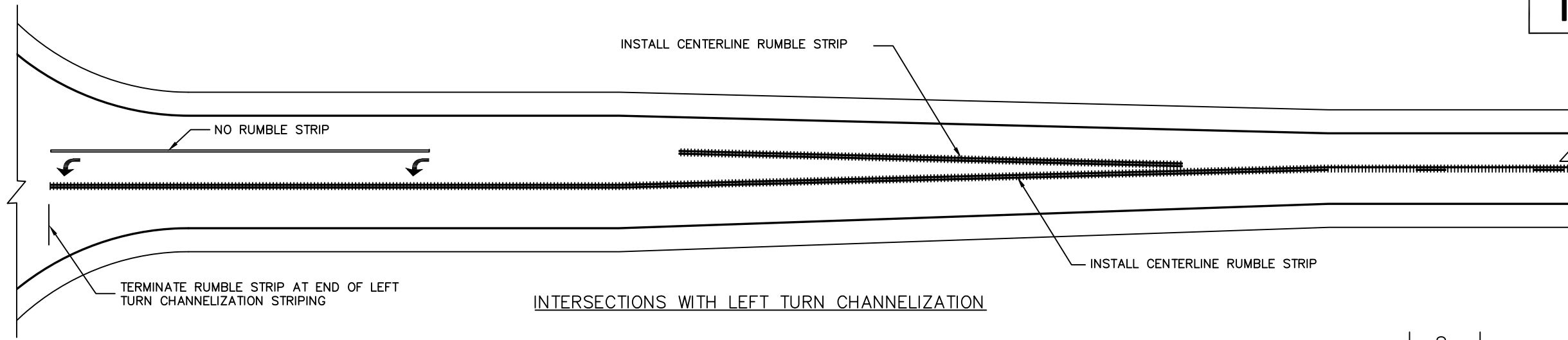

INTERSECTIONS WITH LEFT TURN CHANNELIZATION

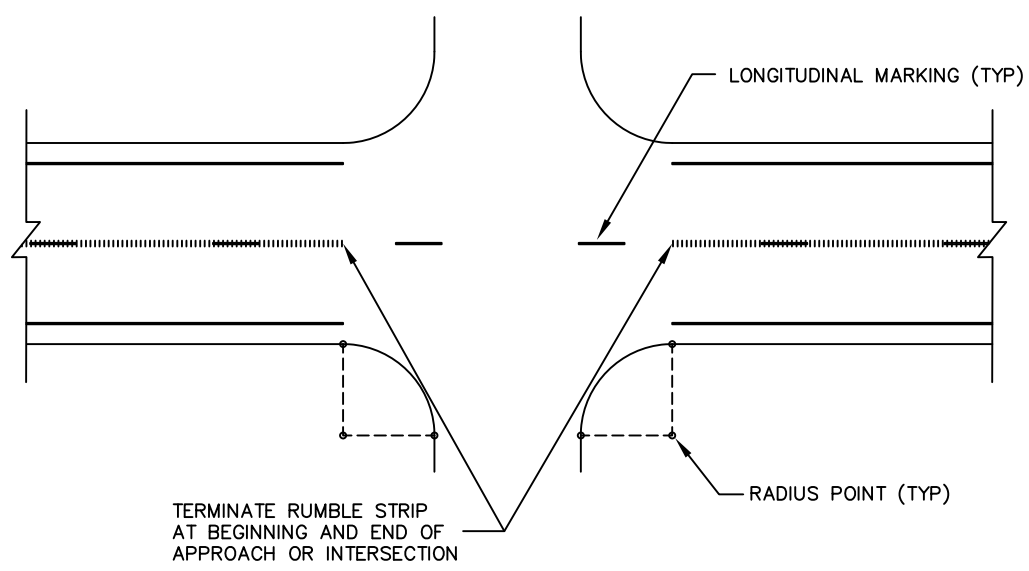

HIGHER VOLUME INTERSECTIONS AND COMMERCIAL APPROACHES

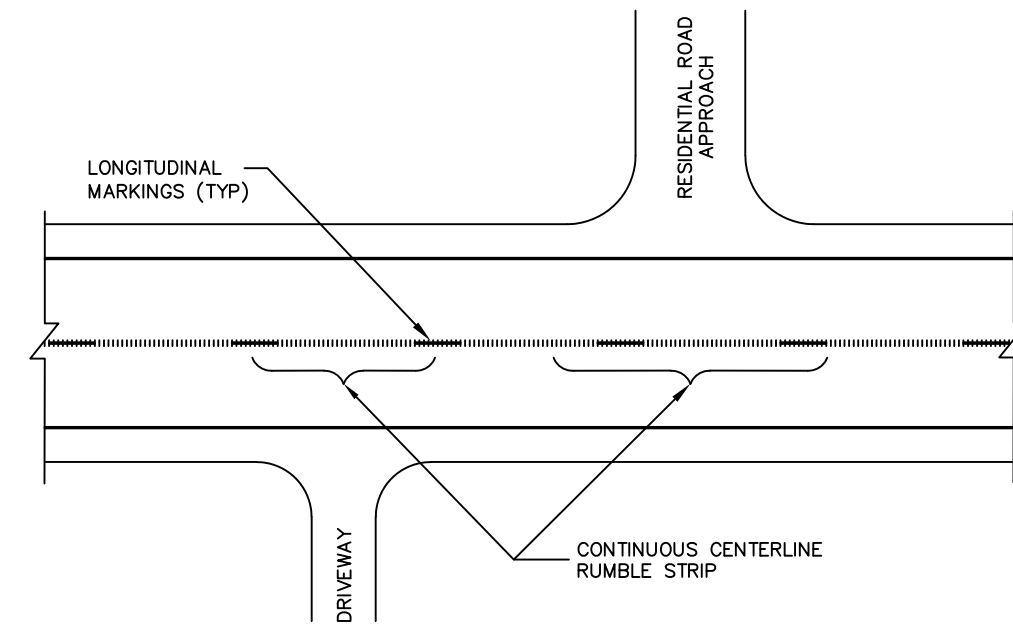

NON-COMMERCIAL ROAD AND DRIVEWAY APPROACHES

(DO NOT BREAK FOR THESE ACCESS POINTS)

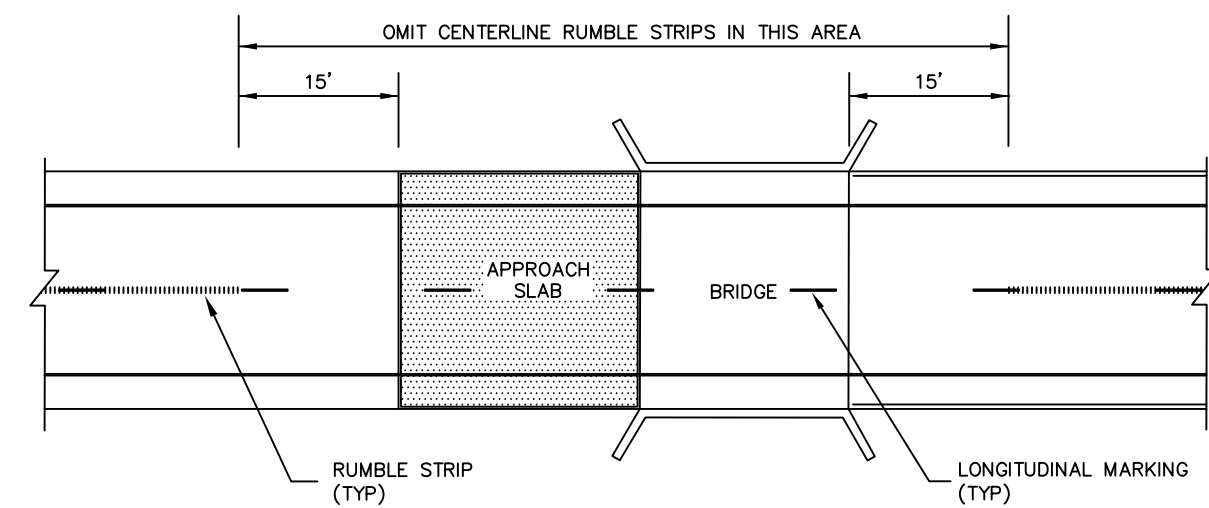

BRIDGE

Note: Drawing not to scale

State of Alaska DOT&PF
ALASKA STANDARD PLAN
MILLED RUMBLE STRIPS
CENTERLINE DETAILS

Adopted as an Alaska Standard Plan by: *Carolyn Morehouse*
Carolyn Morehouse, P.E.
Chief Engineer

Adoption Date: 07/17/2020

Last Code and Stds. Review
By: LRG Date: 07/17/2020

Next Code and Standards Review date: 07/17/2030

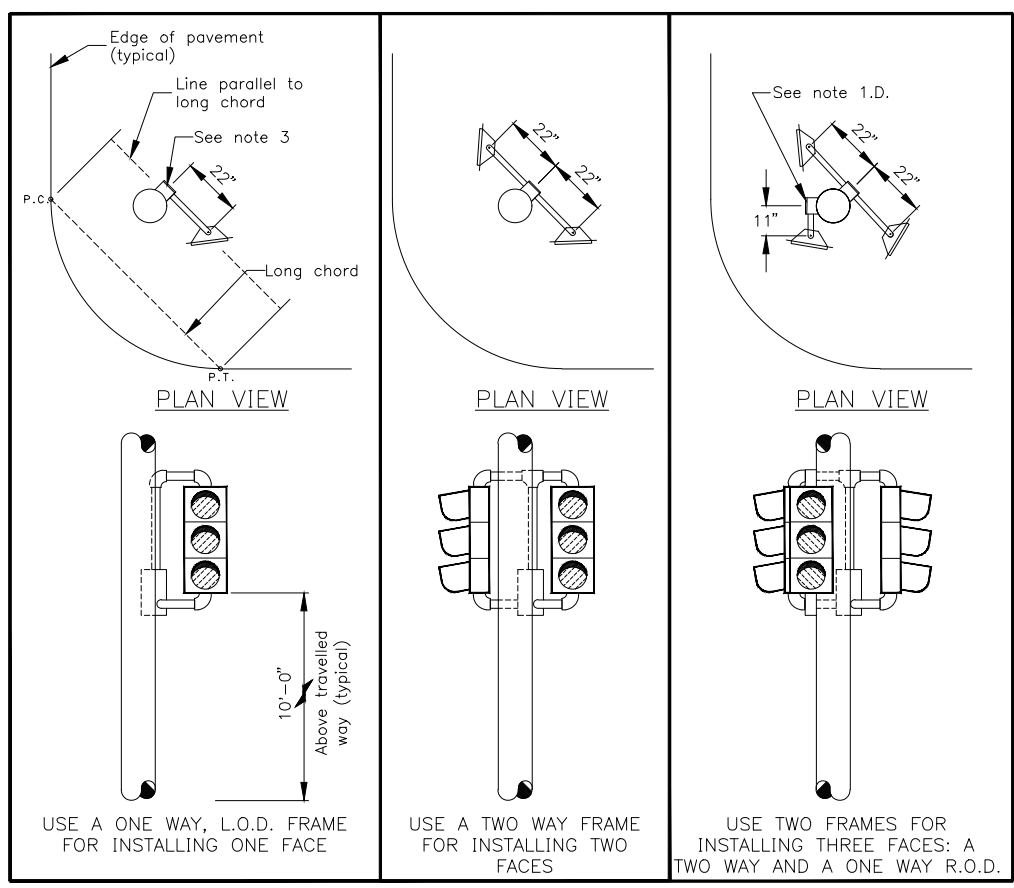

SIDE MOUNTED SIGNAL FRAMES WITH VEHICULAR SIGNALS
(SHOWN WITHOUT BACKPLATES)

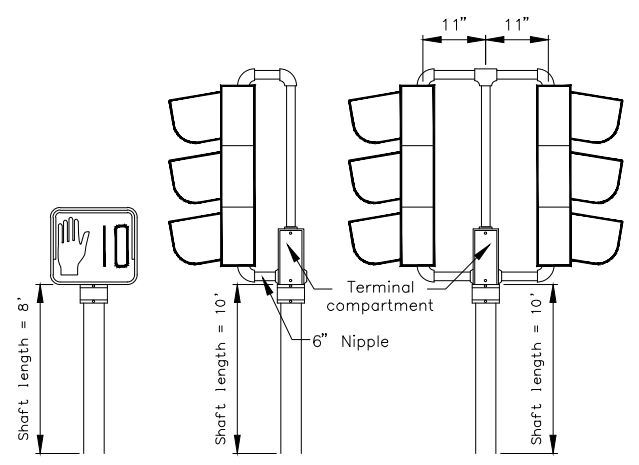

POST MOUNTED SIGNALS
(SHOWN WITHOUT BACKPLATE)

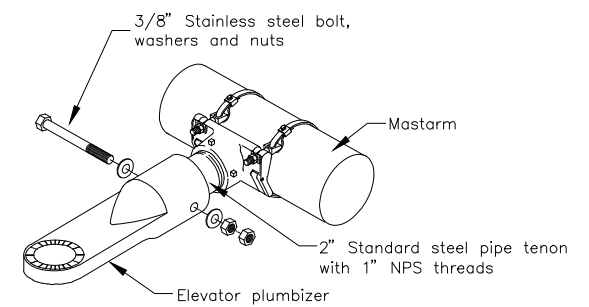

ELEVATOR PLUMBIZER
(SEE NOTE 1.A.)

NOTES:

1. Install the signal faces shown in the plans as detailed on this sheet and per Alaska Traffic Manual.
 - A. Use elevator plumbizers to install faces on mastarms and whenever two inch pipe tenons are specified. Install the plumbizer between the red and yellow signal (between green and yellow for Northern Region) indications for a three section head and between the two yellow signal indications for a four section head. Use stainless steel band mount hardware, AB-3007-L as manufactured by PELCO PRODUCTS, INC., or approved equal to install plumbizer to mastarms. PELCO mount shall have stainless steel option.
 - B. Use slip fitters to install pedestrian signals on the top of posts.
 - C. Use signal frames to install signal faces on the sides of poles and on the tops of posts.
 - D. Use a second signal frame to install the third face when three side mounted signal faces are shown.
 - E. Use clamshell brackets to install all pedestrian signals, except those that are post top mounted.
2. Furnish all signal frames with terminal compartments.
3. Install one terminal compartment on the side of the pole opposite the midpoint of the radius return. Position the terminal compartment at the location where a line parallel to the long chord (P.C. to P.T.) of the radius return is tangent to the pole.
4. Install pedestrian indication to face the center of the far side crosswalk. Acceptable variance is +/- 1 degree.
5. Field drill the holes needed for attaching all signal hardware. Use hole saws when drill bits are not available. Treat the bare steel surfaces in accordance with Section 660-3.01.8, repairing damaged finishes, of the Standard Specifications.
6. Provide solid backplates (lowered in Southcoast Region) sized for the number of signal sections and mounting type, so that no light is visible between the backplate and the signal face. Furnish backplates for doghouse style signals that feature notched upper corners.
7. Attach all back plates using plated steel rivets with large flange button heads. Install 0.187" diameter by 0.575" long rivets that provide at least 530 lbs. and 670 lbs. shear and tensile strengths, respectively. Bore out the mounting holes in the back plates and signal heads to the diameter recommended by the rivet manufacturer.
8. Before installing the machine screws that secure the visors, coat the threads with an anti-seizing compound.

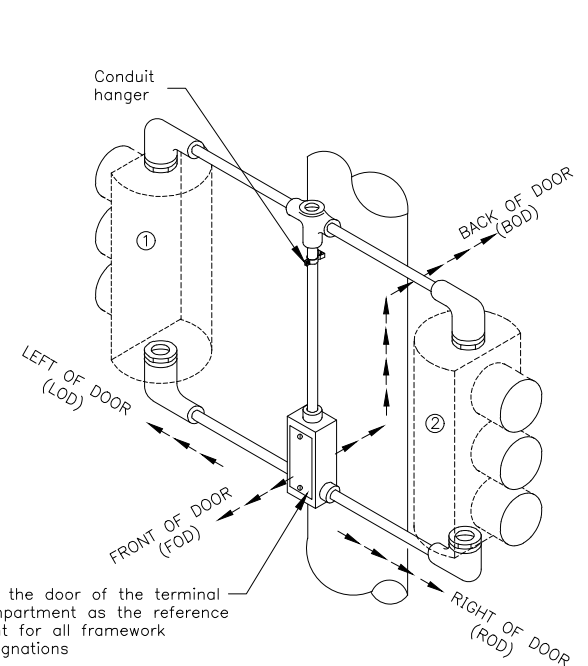

TERMINAL COMPARTMENT WITH SLIP FITTER
(SEE NOTES 1.C. AND 2)

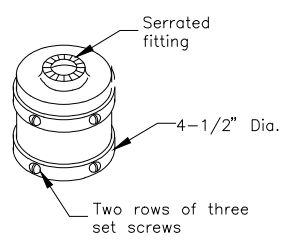

SLIP FITTER
(SEE NOTE 1.B.)

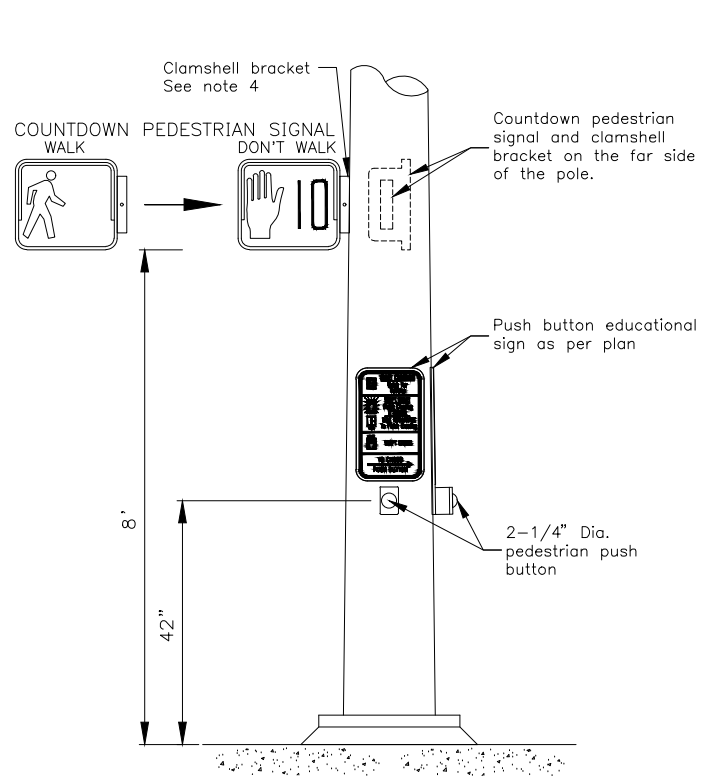

PEDESTRIAN HARDWARE

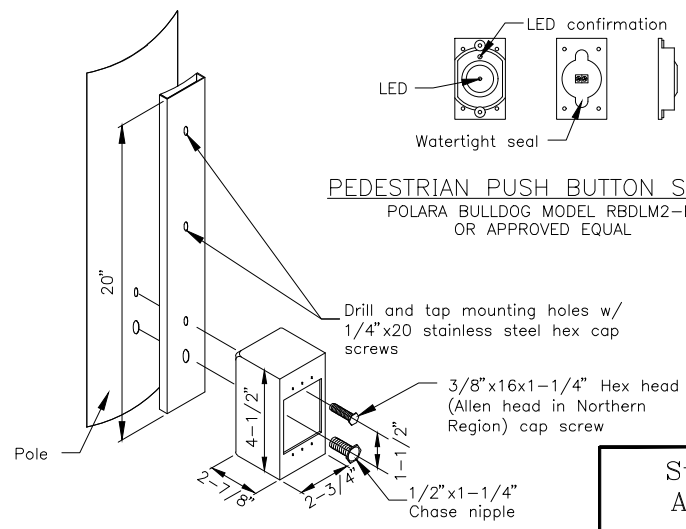

PEDESTRIAN PUSH BUTTON HOUSING (STYLE A)

Use the door of the terminal compartment as the reference point for all framework designations

FRAMEWORK DESCRIPTION
HEAD NO. ① OFFSET L.O.D.
HEAD NO. ② OFFSET R.O.D.

State of Alaska DOT&PF
ALASKA STANDARD PLAN

TRAFFIC SIGNAL HARDWARE

Adopted as an Alaska Standard Plan by: *Carolyn Morehouse*
Carolyn Morehouse, P.E.
Chief Engineer

Adoption Date: 7/17/2020

Last Code and Stds. Review
By: KLK Date: 7/8/2020
Next Code and Standards Review Date: 7/8/2030

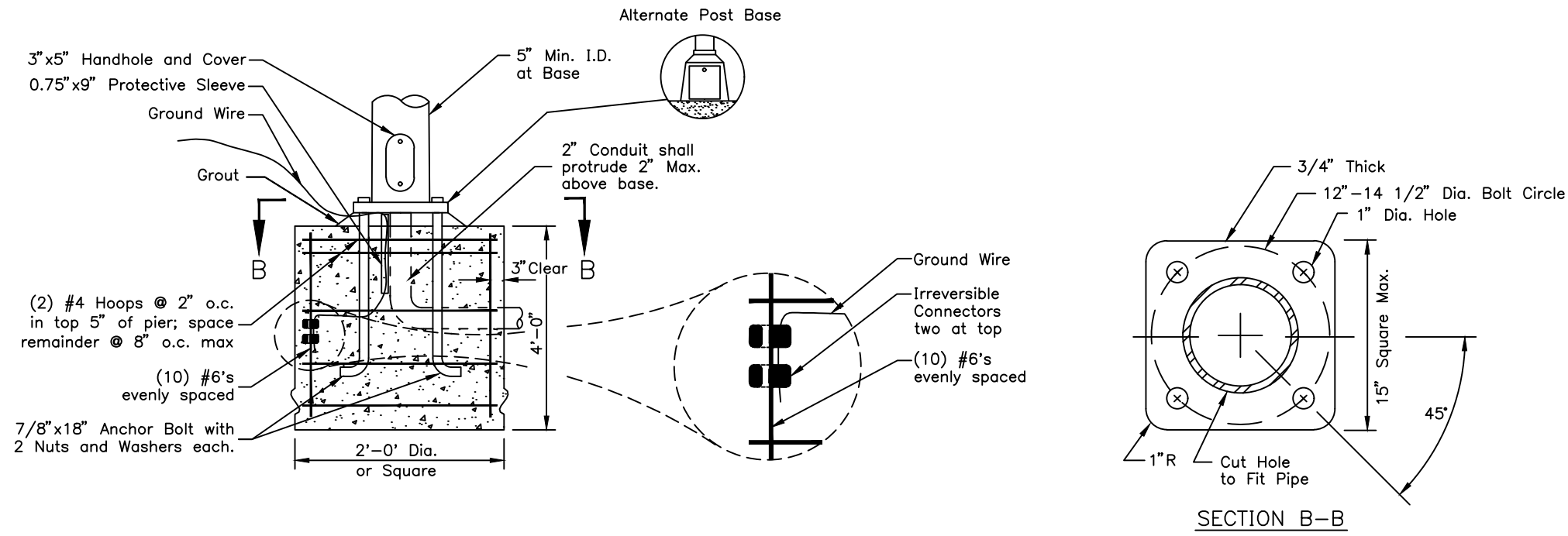

SIGNAL BASE POST TYPE "A"

GENERAL NOTES:

1. Install ground rod when continuous electrically secure system is not provided between controller and service ground.
2. Anchor bolts, nuts and washers shall be high strength steel and shall conform to A.S.T.M. A-325. Galvanizing of same shall conform to A.S.T.M. A-153.
3. Anchor bolts may be field cut and bent.
4. Damage to galvanized surfaces as a result of field drilling and or cutting shall be repaired in accordance with Federal Specifications TT-P-641.
5. Use Class A, B, or W concrete.
6. Reinforcing steel to conform to A.S.T.M. A-615 grade 60 (Fy=60 ksi).

State of Alaska DOT&PF
ALASKA STANDARD PLAN

**TRAFFIC SIGNAL &
ACCESSORIES FOUNDATION**

Adopted as an Alaska Standard Plan by: *Carolyn Morehouse*
Carolyn Morehouse, P.E.
Chief Engineer

Adoption Date: 7/17/2020

Last Code and Stds. Review
By: KLK, MJM Date: 7/8/2020
Next Code and Standards Review Date: 7/8/2030

T-31.01

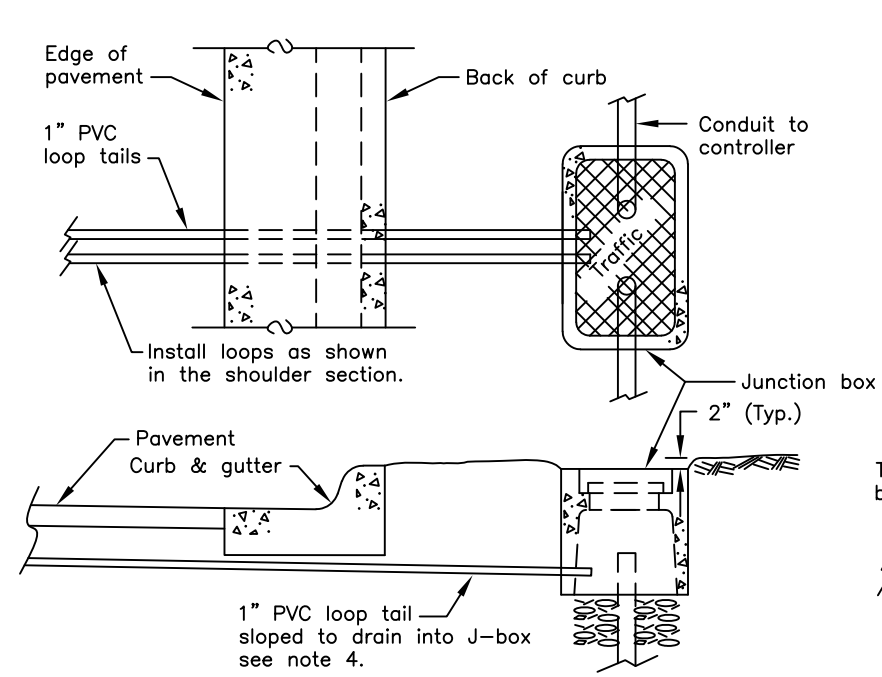

CURB SECTION

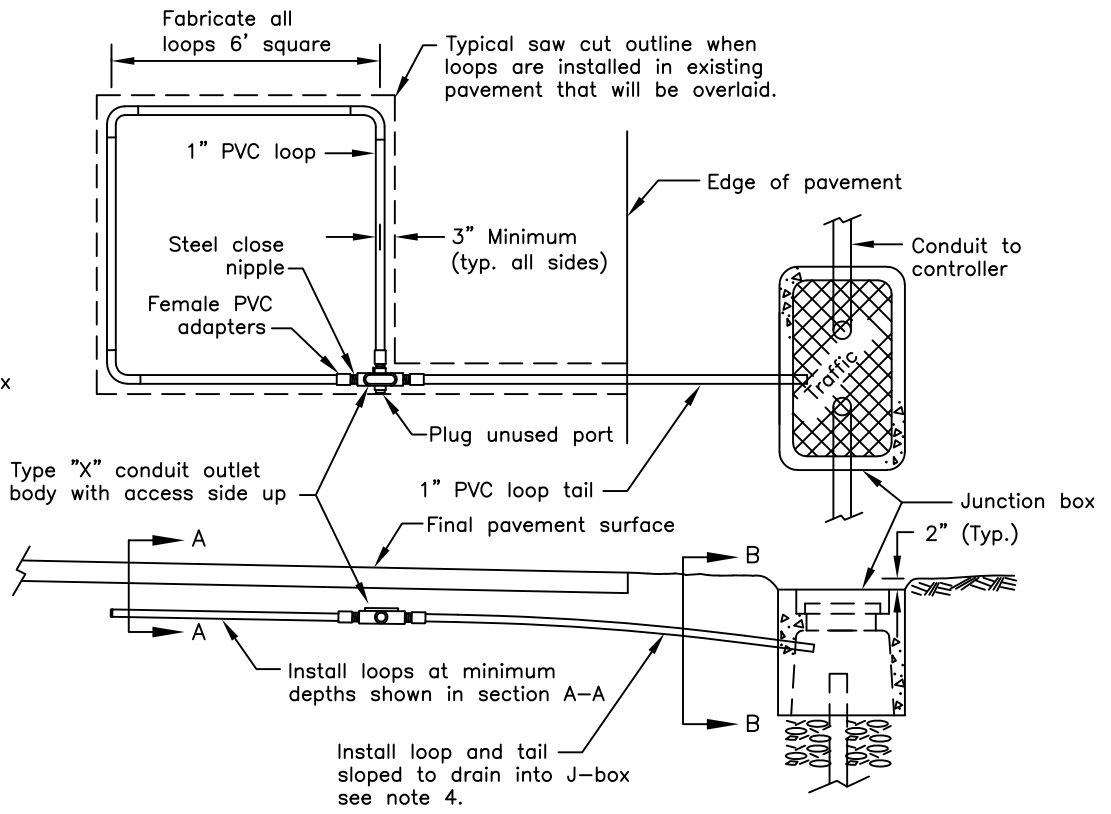

SHOULDER SECTION

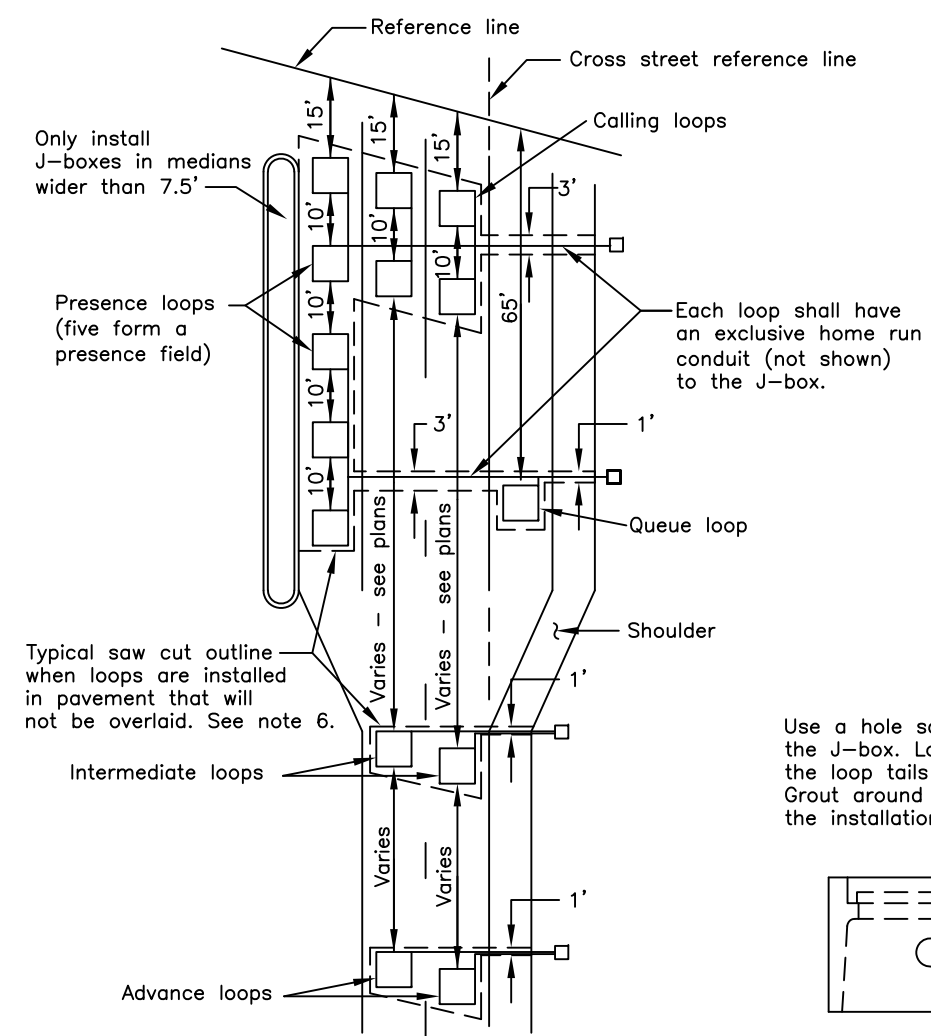

TYPICAL LOOP SETBACKS

Measure the setbacks from the reference line along the center of each lane.

Use a hole saw to cut loop tail entry into the J-box. Locate the hole to ensure the loop tails drain into the J-box. Grout around the loop tails to complete the installation.

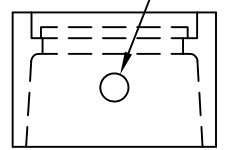

VIEW B-B

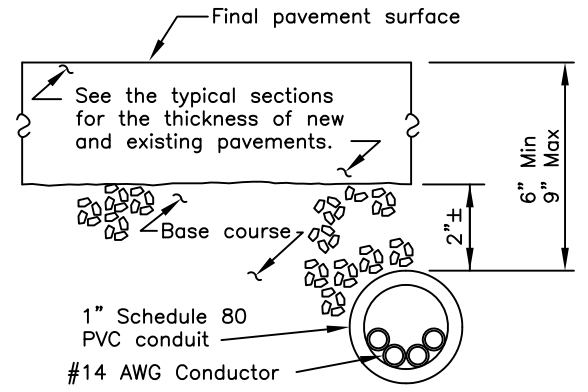

SECTION A-A

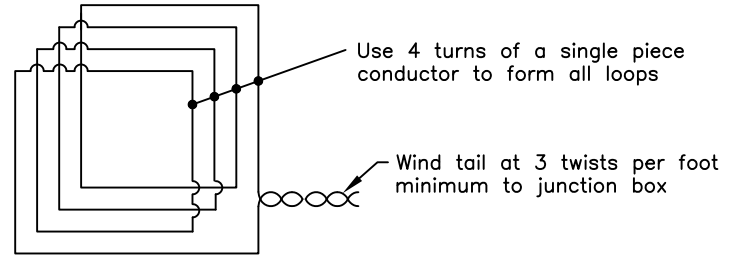

LOOP WIRING DETAIL

TYPICAL PVC CONDUIT ENCASED LOOP DETECTOR INSTALLATION

GENERAL NOTES

- Solvent weld all PVC to PVC joints. Use hot dip galvanized steel type X outlet bodies to join the loops and tails.
- Use tube loop wire per IMSA specification 51-5 with the optional polyethylene tubing.
- Install and test all loop detectors before overlaying the existing pavement or paving the new roadway.
- Drill five 1/4" weep holes on 12" centers in the underside of the conduit at the low spot when the loop and tail cannot be installed to drain into the J-box. If the Engineer allows 90 degree elbows to be used, drill a 1/4" hole in the low point.
- When installing loop detectors in existing pavement, cut the asphalt with a saw and remove all asphalt within the saw cut.
- Where existing pavement will not be overlaid, cut the pavement with a saw as follows:
 - Remove all pavement from the length of the five loop presence fields.
 - Enclose all loops that enter a common junction box within one saw cut area.
 - Cut to within 12" of lane and edge lines to preserve them.
 - Remove asphalt to gutter where there are no edge lines.
 - Cut across lane lines when loops are side by side.
 - Cut trenches crossing a lane a minimum of 3' wide.
 - Cut trenches crossing a shoulder a minimum 12" wide.
- Heat and tack coat the edges of existing pavement before paving cutouts. Compact the asphalt mixture with a self-propelled steel wheeled roller. Furnish asphalt mix that conforms to section 401 of the Specifications, and is approved by the Engineer. Maintain the replacement asphalt temperature at the mixing temperature specified in the approved mix design until compaction has begun.
- To establish the reference lines, extend the right edges of the outermost through lanes across the intersection.

State of Alaska DOT&PF
ALASKA STANDARD PLAN
LOOP DETECTOR
INSTALLATION

Adopted as an Alaska Standard Plan by: *Kenneth J. Fisher*
Kenneth J. Fisher, P.E.
Chief Engineer

Adoption Date: 02/08/2019

Last Code and Stds. Review By: Date:

Next Code and Standards Review date: 02/08/2029

GENERAL NOTES

1. Install anchor bolts so they do not protrude more than 1 1/2" above the top of the foundation. Anchor bolt dimensions shall be as specified by the cabinet manufacturer.
2. Provide all conduit ends with grounding bushings. Seal unused conduit stubs with watertight caps. Provide a one pound package of duct seal compound to be installed in conductor carrying conduit stubs by signal technicians during final inspection.
3. Route the #6 copper grounding jumper from the ground rod through the 2" pipe nipple and attach it to the grounding bushing on the feeder cable conduit.
4. Bond the braided copper grounding conductor to the #6 copper grounding jumper using an irreversible compression connector. Provide sufficient slack such that there will be a minimum of 3' conductor to extend past the lid opening.
5. Stop horizontal and vertical steel at the block-out panels and the joint using 90° hooks. Place 2 extra #5 horizontal and vertical bars all sides as shown.

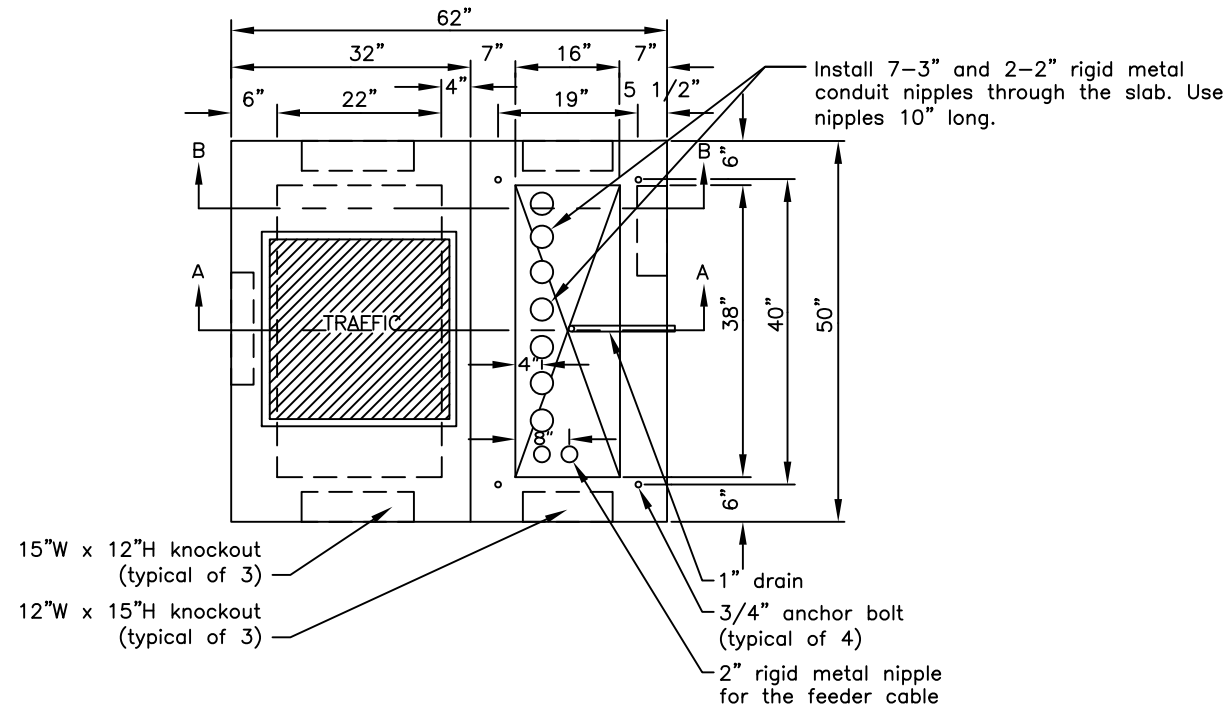

TYPE "P" or "R" CONTROLLER CABINET FOUNDATION

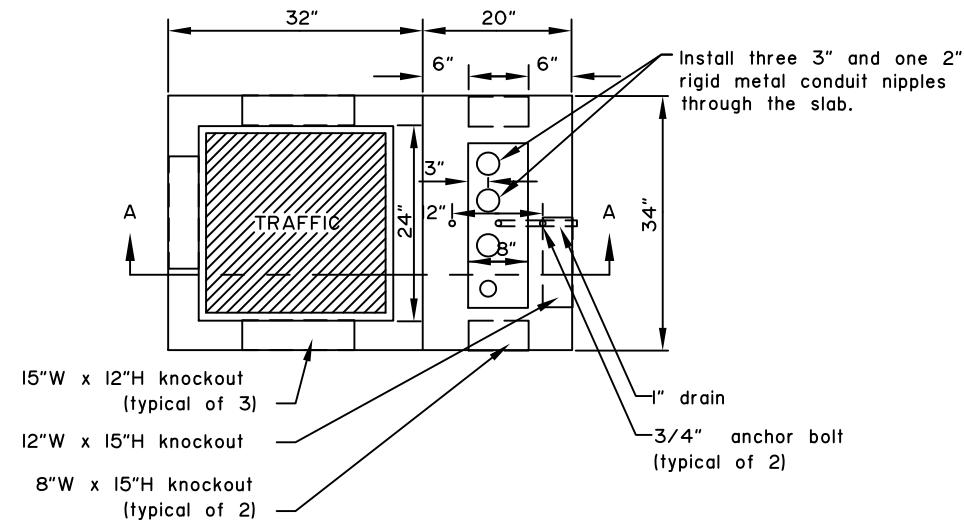

TYPE "M" CONTROLLER CABINET FOUNDATION

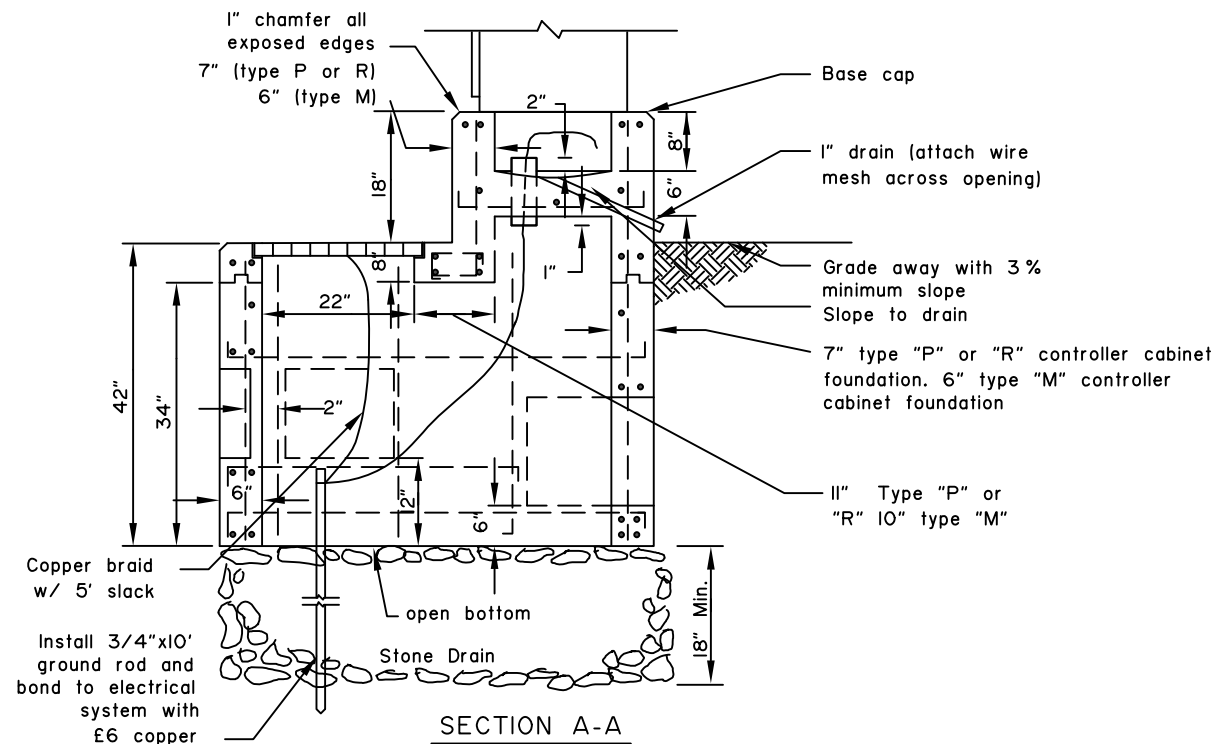

NOTE: see section "B-B" for rebar details.

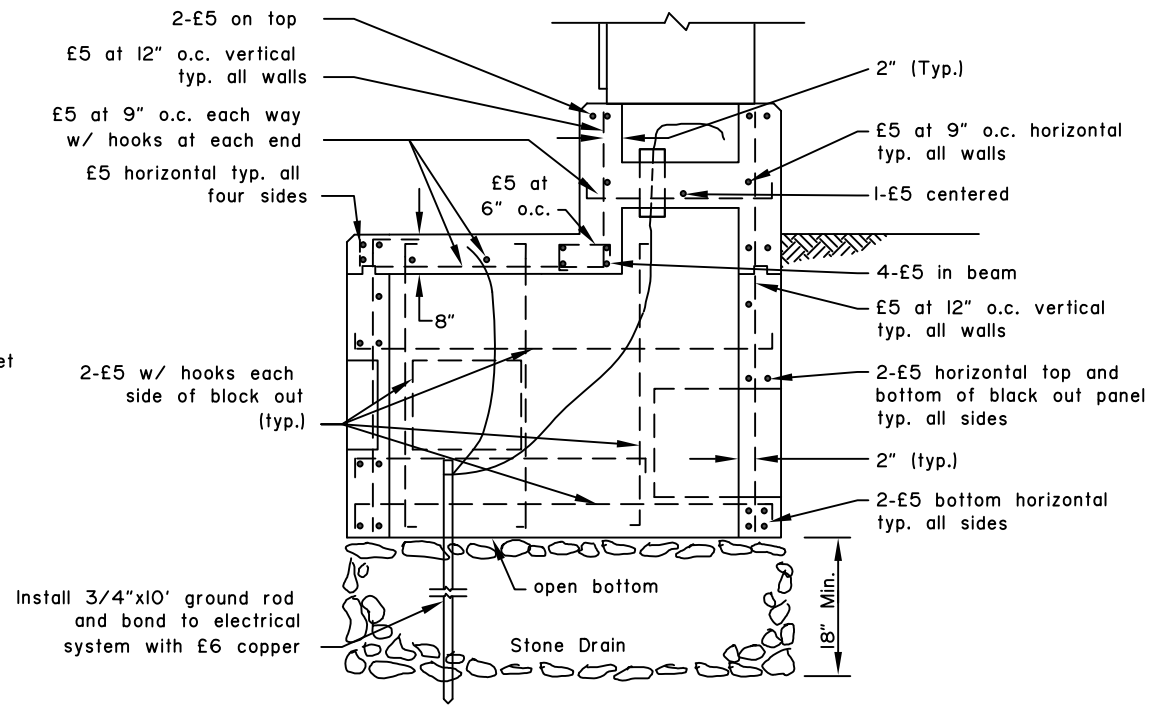

NOTES: see section "A-A" for dimensional details & notes.

State of Alaska DOT&PF
ALASKA STANDARD PLAN
CONTROLLER CABINET
FOUNDATION

Adopted as an Alaska
Standard Plan by: *Kenneth J. Fisher*
Kenneth J. Fisher, P.E.
Chief Engineer

Adoption Date: 02/08/2019

Last Code and Stds. Review
By: Date:

Next Code and Standards Review date: 02/08/2029

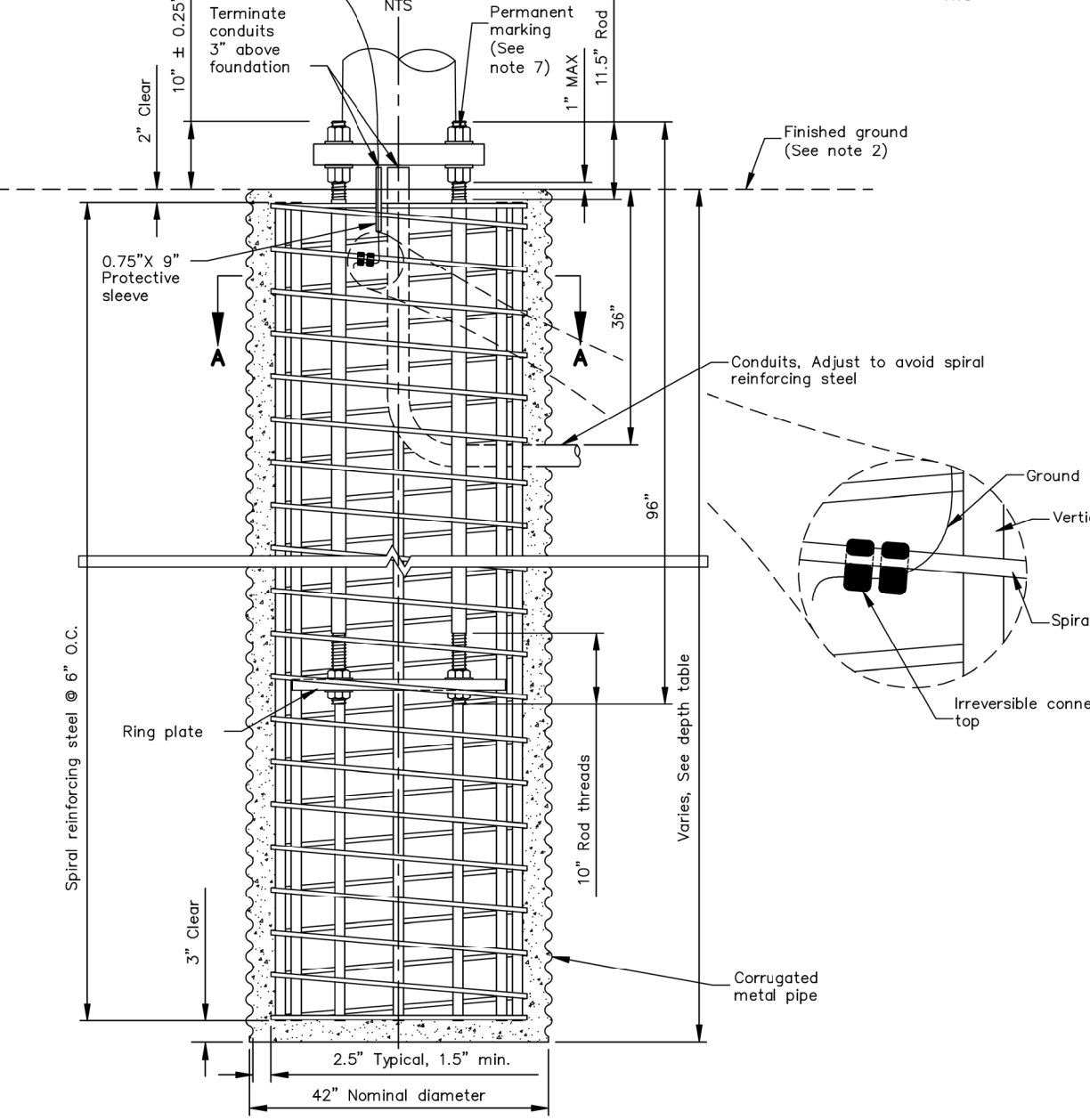
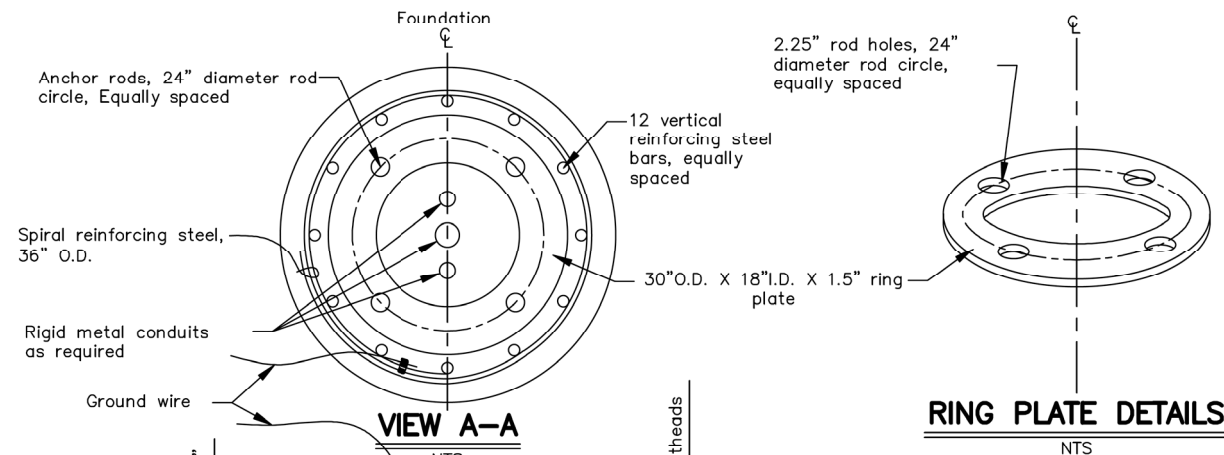

FOUNDATION DETAILS
Skirt omitted for clarity

MATERIAL REQUIREMENTS		
Concrete	Class A	f'c = 4000 psi
CMP	AASHTO M218	14 ga.
Vertical reinforcing steel	AASHTO M31 #9	GR 60
Spiral reinforcing steel	AASHTO M31 #5	GR 60
Ground wire		#4 awg
Anchor rods 2" X 96"	ASTM F1554 S2, S3, & S5	GR 105
Fasteners, washers	ASTM F436	
Fasteners, nuts	AASHTO M292M	
Finish, anchor rods & fasteners	AASHTO M232	
Ring plate	AASHTO M270	GR 36
Conduit	Sch 40	RMC
Protective sleeve	Sch 40	PVC

DEPTH TABLE (See design notes for loads)	
Mastarm length (ft.)	Foundation depth (ft.) Single mastarm
L ≤ 40	10
40 < L ≤ 50	11
50 < L ≤ 65	12

CONTROLLED LOW DENSITY MATERIAL MIX DESIGN		
Item	Batching quantities per cy batch (lbs.)	Applicable specs.
Portland Cement	188	701-2.01
Water (52.1 gal.)	435	712-2.01
Fine Aggregate SSD	3041	703-2.01
Admixture Entrainment	Air 2.0 oz.	711-2.02
Total	3664	

DESIGN NOTES:

Design Standard: 2013 Standard Specifications for Structural Supports for Highway Signs, Luminaires and Traffic Signals with 2013 Errata 2019 and 2020 Interim Revisions (SSSS).

Maximum Unfactored Service Loads (SSSS):

Axial	Shear	Moment	Torsion	Length
6,500 LBS	5,200 LBS	117,200 FT-LBS	68,800 FT-LBS	L ≤ 40
7,000 LBS	5,300 LBS	131,200 FT-LBS	98,700 FT-LBS	40 < L ≤ 50
9,000 LBS	6,400 LBS	215,100 FT-LBS	162,500 FT-LBS	50 < L ≤ 65

Wind: Foundations shall not be used for locations over 100 mph basic wind speed as shown in the 2013 SSSS figure 3.0.3-1.

Soil: This foundation is approved for traffic signal applications in cohesionless soils with an N1-60 value of 20 or greater per AASHTO T-206, "Standard Penetration Test" (SPT) and soil density = 120 pcf and friction angle of 32.5 degrees.

NOTES:

- This foundation shall not be used if any of the following are encountered: water table above the bottom of foundation, very loose soils, organic soils, cohesive soils (clay), slopes steeper than 6:1, or soils susceptible to frost jacking. If any of these conditions are encountered, stop foundation work and contact the engineer.
- Place foundation in drilled or excavated hole with centerline of foundation located at the station, offset, and elevation specified in plans. Set foundation flush with surrounding surface. Grade to drain away from foundation without exposing more than 4" of the foundation from the surrounding ground surface.
- Form the foundation in corrugated metal pipe conforming to Subsection 707-2.01 of the Specifications.
- Provide 1.5 extra turns at each end of the spiral reinforcing steel. Reinforcing steel shall not be spliced. Tie vertical reinforcing steel to each intersection of the spiral reinforcing steel.
- Connect ground wire near the top spiral reinforcing steel with two irreversible connectors as shown. Fasten connectors according to the manufacturers' recommendations including the use of manufacturer specified tools. The ground wire may be bare solid, stranded, or braided copper. Protect ground wire with protective sleeve as shown and fill with silicon sealant.
- The ring plate may be "built up" of multiple steel plates. The minimum thickness for any one plate is 0.5 inches. Fasten the ring plate to anchor rods with nuts and washers on both sides of ring plate as shown. Torque ring plate nuts to 600 ft-lbs.
- Anchor rods are subject to Charpy V-Notch Impact Testing. Submit mill certifications for anchor rods, nuts and washers. Galvanize anchor rods full length. Provide permanent manufacturer's identification and permanent grade identification on each end of anchor rod by steel die stamp. Secure exposed anchor rods with a "ring plate" when not in service. Install anchor rods plumb. Anchor rods greater than 1:40 out-of-plumb will result in foundation rejection.
- Dual mast arms are not included in this standard and shall have custom designs.
- Backfill and compact according to Section 204, and Subsections 203-3.04 and 660-3.01 of the Specifications. Use select material, Type A or controlled low density material as backfill material. Ensure area below foundation meets compaction requirements and is free of loose material and debris prior to concrete work.

State of Alaska DOT&PF
ALASKA STANDARD PLAN
CONCRETE 42" DIAMETER
SIGNAL POLE FOUNDATION

Adopted as an Alaska
Standard Plan by: 
Lauren Little, P.E.
Interim Chief Engineer
Adoption Date: 01/29/2024

Last Code and Stds. Review
By: AH Date: 12/13/2023
Next Code and Standards Review Date: 12/13/2033

T-52.23

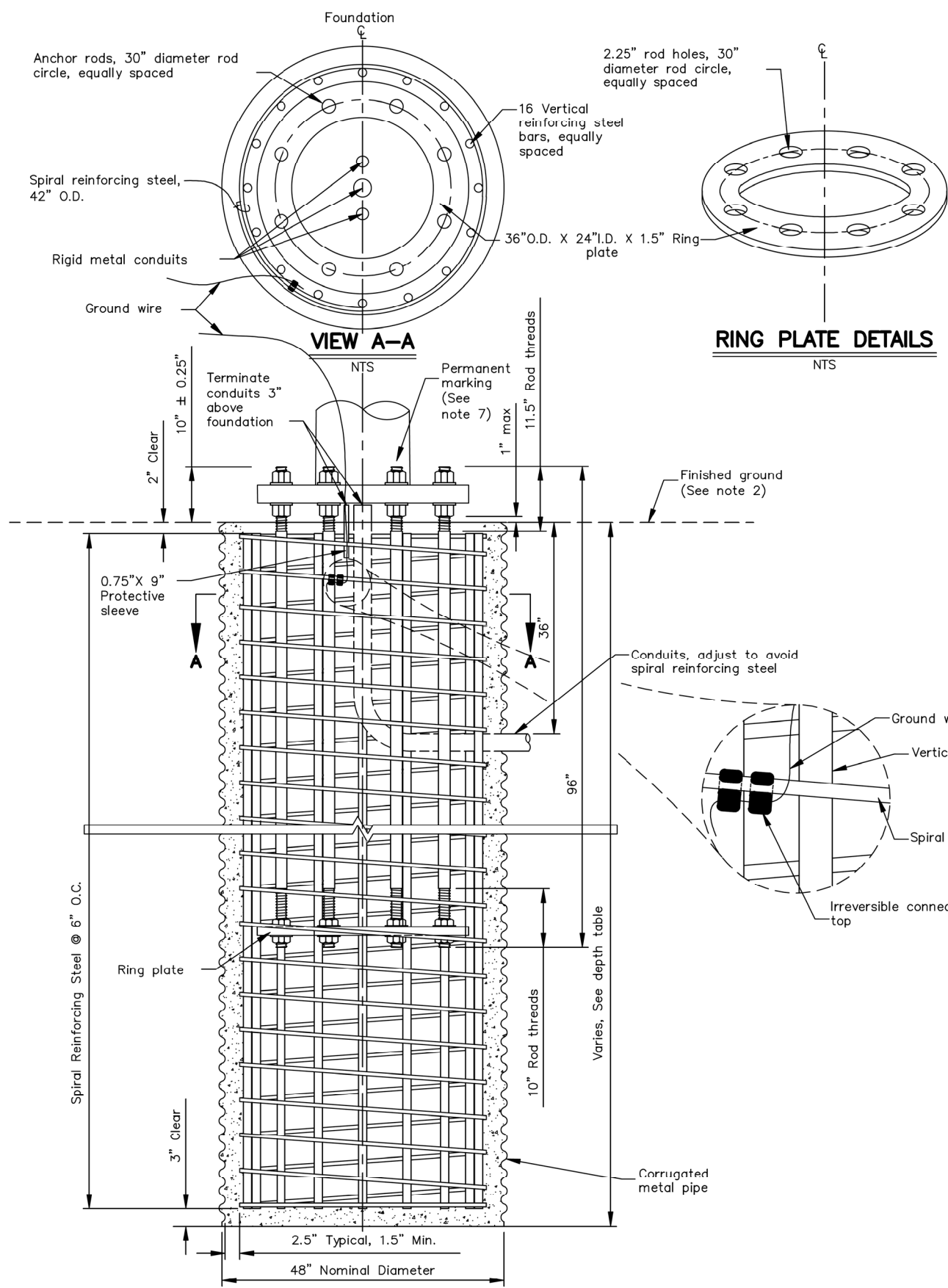

FOUNDATION DETAILS
Skirt omitted for clarity

MATERIAL REQUIREMENTS		
Concrete	Class A	f'c = 4000 psi
Cmp	AASHTO M218	14 ga.
Vertical reinforcing steel	AASHTO M31 #9	GR 60
Spiral reinforcing steel	AASHTO M31 #5	GR 60
Ground wire		#4 awg
Anchor rods 2" X 96"	ASTM F1554 S2, S3, & S5	GR 105
Fasteners, washers	ASTM F436	
Fasteners, nuts	AASHTO M292M	
Finish, anchor rods & fasteners	AHTO M232	
Ring plate	AASHTO M270	GR 36
Conduit	Sch 40	RMC
Protective sleeve	Sch 40	PVC

DEPTH TABLE (See Design Notes for Loads)	
Mastarm length (ft.)	Foundation depth (ft.)
	Single mastarm
65 < L ≤ 75	12

CONTROLLED LOW DENSITY MATERIAL MIX DESIGN		
Item	Batching quantities per cy batch (lbs.)	Applicable specs.
Portland cement	188	701-2.01
Water (52.1 gal.)	435	712-2.01
Fine aggregate ssd	3041	703-2.01
Admixture	Air	2.0 OZ.
Entrainment		/11-2.02
Total	3664	

DESIGN NOTES:

- Design Standard: 2013 Standard Specifications for Structural Supports for Highway Signs, Luminaires and Traffic Signals with 2013 Errata and 2019 and 2020 Interim Revisions (SSSS).
- Maximum Unfactored Service Loads (SSSS): 11,000 lbs axial, 7,100 lbs shear, 268,400 ft-lbs moment, 197,600 ft-lb torsion.
- Wind: This standard shall not be used for locations over 100 mph basic wind speed as shown in the 2013 SSSS, figure 3.8.3-1
- Soil: This foundation is approved for traffic signal applications in cohesionless soils with an N1-60 value of 20 or greater per AASHTO T-206, "Standard Penetration Test" (SPT) and soil density = 120 pcf and friction angle of 32.5 degrees.

NOTES:

- This foundation shall not be used if any of the following are encountered: water table above the bottom of foundation, very loose soils, organic soils, cohesive soils (clay), slopes steeper than 6:1, or soils susceptible to frost jacking. If any of these conditions are encountered, stop foundation work and contact the engineer.
- Place foundation in drilled or excavated hole with centerline of foundation located at the station, offset, and elevation specified in plans. Set foundation flush with surrounding surface. Grade to drain away from foundation without exposing more than 4" of the foundation from the surrounding ground surface.
- Form the foundation in corrugated metal pipe conforming to Subsection 707-2.01 of the Specifications.
- Provide 1.5 extra turns at each end of the spiral reinforcing steel. Reinforcing steel shall not be spliced. Tie vertical reinforcing steel to each intersection of the spiral reinforcing steel.
- Connect ground wire near the top spiral reinforcing steel with two irreversible connectors as shown. Fasten connectors according to the manufacturers' recommendations including the use of manufacturer specified tools. The ground wire may be bare solid, stranded, or braided copper. Protect ground wire with protective sleeve as shown and fill with silicon sealant.
- The ring plate may be "built up" of multiple steel plates. The minimum thickness for any one plate is 0.5 inches. Fasten the ring plate to anchor rods with nuts and washers on both sides of ring plate as shown. Torque ring plate nuts to 600 ft-lbs.
- Anchor rods are subject to Charpy V-Notch Impact Testing. Submit mill certifications for anchor rods, nuts and washers. Galvanize anchor rods full length. Provide permanent manufacturer's identification and permanent grade identification on each end of anchor rod by steel die stamp. Secure exposed anchor rods with a "ring plate" when not in service. Install anchor rods plumb. Anchor rods greater than 1:40 out-of-plumb will result in foundation rejection.
- Dual mast arms are not included in this standard and shall have custom designs.
- Backfill and compact according to Section 204, and Subsections 203-3.04 and 660-3.01 of the Specifications. Use select material, Type A or controlled low density material as backfill material. Ensure area below foundation meets compaction requirements and is free of loose material and debris prior to concrete work.

State of Alaska DOT&PF
ALASKA STANDARD PLAN
**CONCRETE 48" DIAMETER
SIGNAL POLE FOUNDATION**

Adopted as an Alaska Standard Plan by: 
Lauren Little, P.E.
Interim Chief Engineer

Adoption Date: 01/29/2024

Last Code and Stds. Review
By: AH Date: 12/13/2023
Next Code and Standards Review Date: 12/13/2033

T-53.02

POLE DESIGN LOADING						
Load Component	Height (ft.)	Weight (lbs.)	Ice Area (sq. ft.)	Wind Area (Face) (sq. ft.)	Wind Area (Side) (sq. ft.)	Fatigue Area (Bottom) (sq. ft.)
1 = Luminaire	0.5	25	8.1	0.6	1.0	2.5
2 = Signal	4.5	54	2.9	8.7	4.8	1.4
3 = Signal	5.6	70	37.5	11.0	6.4	1.4
4 = Ped Head	1.4	22	7.8	2.2	0.8	0.9
5 = Sign	2.5	120	69.7	30.0	0.8	4.0

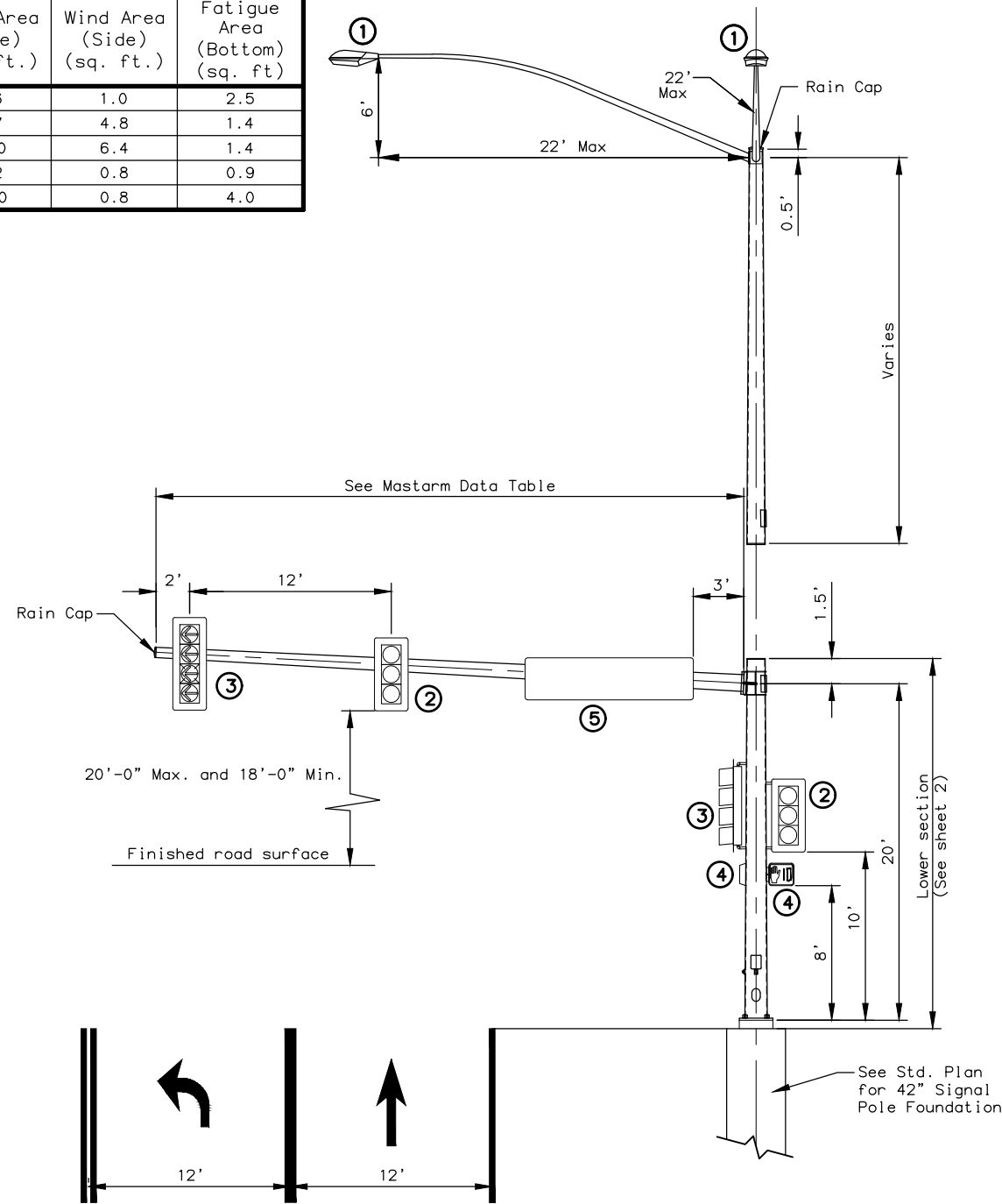

ELEVATION VIEW
NTS

NOTES:

- Provide pole assemblies designed, manufactured and installed according to: 2013 AASHTO Standard Specifications for Structural Supports for Highway Signs, Luminaires and Traffic Signals with 2013 Errata and 2015 Interim Revision, the latest edition of the Alaska Standard Specifications for Highway Construction including standard modifications, and special provisions. Design structures for a 50-year Design Life, Fatigue Category I with ice loading, and with a basic wind speed of 100 mph. Fatigue design shall include Natural Wind Gust and Truck-Induced Gust.
- Provide poles to accommodate the maximum length shown in the mastarm data with the given loads, dimensions, and material requirements.
- This drawing shows loads (signs and signals) to be used by manufacturers when designing poles. It does not show actual loading of poles/mastarms on individual projects. This pole/mastarm design may be used without further analysis if the following conditions are met:
 - The guide sign (load #5) is attached to the mastarm base section and,
 - Not more than 5 traffic signals and/or signs are attached to the mastarm.
 If these conditions are not met, this standard pole/mastarm design may only be used if design computations are submitted that demonstrate conformance to design criteria (note 1) using actual loads. Devices with less than 1 square foot of projected area may be added to the mastarm without causing a need for additional design computations.
- The manufacturer is to determine weld sizes. All welds and testing shall conform to the latest edition of the structural welding code AWS D1.1. Provide visual testing (VT) of 100% of all welds. Provide magnetic particle testing (MT) of 100% of all fillet welds. Provide radiographic (RT) or ultrasonic testing (UT) of 100% of all complete joint penetration welds and a random 25% of all partial joint penetration longitudinal seam welds.
- Fabricate pole tubes and mastarm tubes from no more than 2 pieces of steel. When using 2 pieces, place the longitudinal welded seams directly opposite one another. Transverse weld seams prohibited.
- Fabricate luminaire arms and connections according to the latest lighting standard detail.
- Provide permanent tags on all pole sections per section 740 table 740-1 of the specifications. Provide a weather proof rain cap on all exposed sections of the structure.
- The Department will reject damaged or defective poles for any of the following; variances from approved shop drawings, variances from material requirements, sections more than 2-percent out of round, flanged mounting surfaces with flatness variation greater than 0.030", sections bowed more than 1-inch throughout the length of the pole, mastarm, or segment, and damaged or dented finishes.
- To allow for wiring, field drill a 1" maximum diameter hole at each traffic signal head location. Orient the hole on the horizontal axis of mastarms.
- Install pole raked outward from plumb position in the direction opposite the mastarm such that the side of the pole opposite the mastarm is vertical.
- Clean and remove dirt, burrs, mill scale, and excess galvanization on all faying surfaces and threaded parts before assembly. Lubricate the threads of all bolts and nuts with lubricant containing a visible dye. Tighten all bolts according to section 504 of the specifications.

MASTARM DATA						
MASTARM				MASTARM BASEPLATE		
Length (ft.)	Maximum Allowed Galloping Deflection (in.)	Fixed End Diameter* (in.)	Tube Thickness (in.)	Plate Opening Diameter (in.)	Bolt Circle Diameter (in.)	Plate Thickness (in.)
15	8.0	9.38	0.239	7.0	20.0	3.0
20	8.0	10.05	0.239	7.0	20.0	3.0
25	8.0	10.75	0.239	7.0	20.0	3.0
30	8.0	11.45	0.239	7.0	20.0	3.0
35	8.0	12.15	0.239	7.0	20.0	3.0

*Fixed end diameter measured at connection to Baseplate

State of Alaska DOT&PF
ALASKA STANDARD PLAN

SIGNAL POLE WITH 15' TO 35' MASTARM LOADING & NOTES

Adopted as an Alaska Standard Plan by: *Carolyn Morehouse*
Carolyn Morehouse, P.E.
Chief Engineer

Adoption Date: 7/30/2021

Last Code and Stds. Review
By: Date: 5/13/2021

Next Code and Standards Review date: 5/13/2031

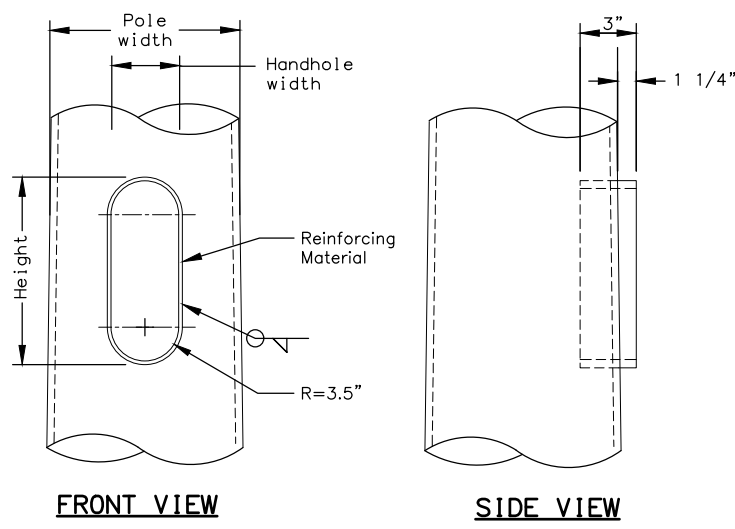

REINFORCED HANDHOLE DETAILS

1
(See material requirements table for dimensions)
NTS

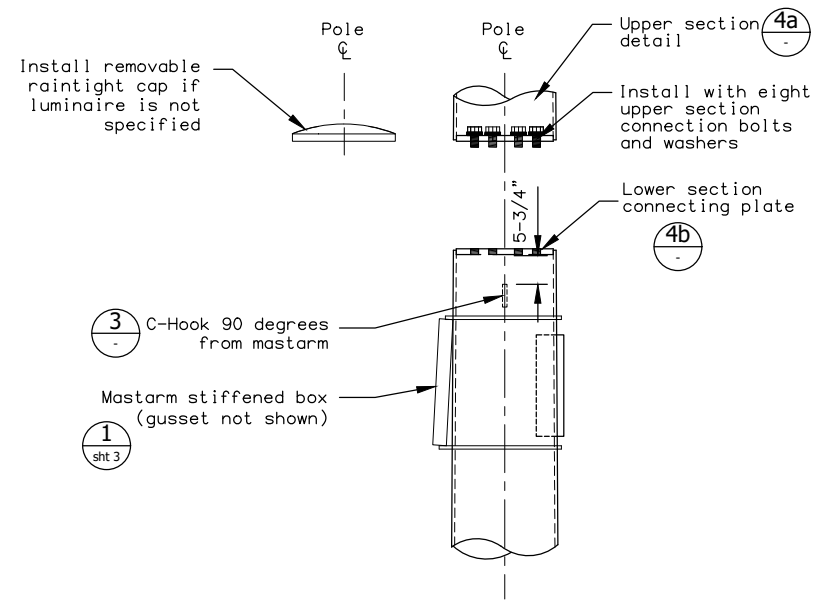

POST TOP LOWER SECTION DETAIL

3
C-Hook 90 degrees from mastarm

1
Mastarm stiffened box (gusset not shown)

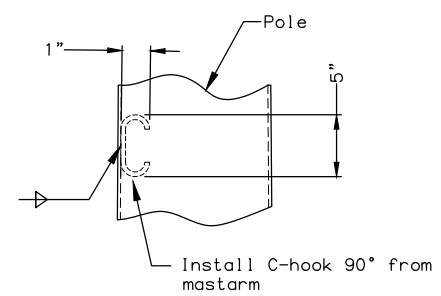

C-HOOK DETAIL
(Typical throughout lower section)
NTS

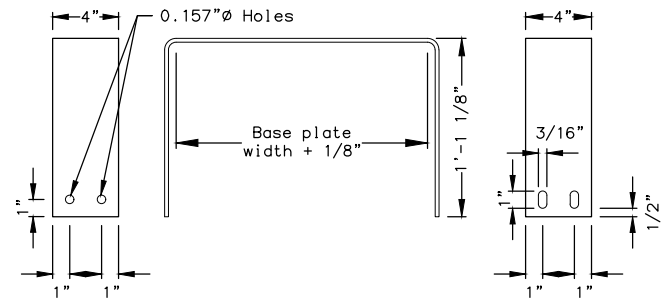

SKIRT DETAIL
NTS
(Two required per pole)

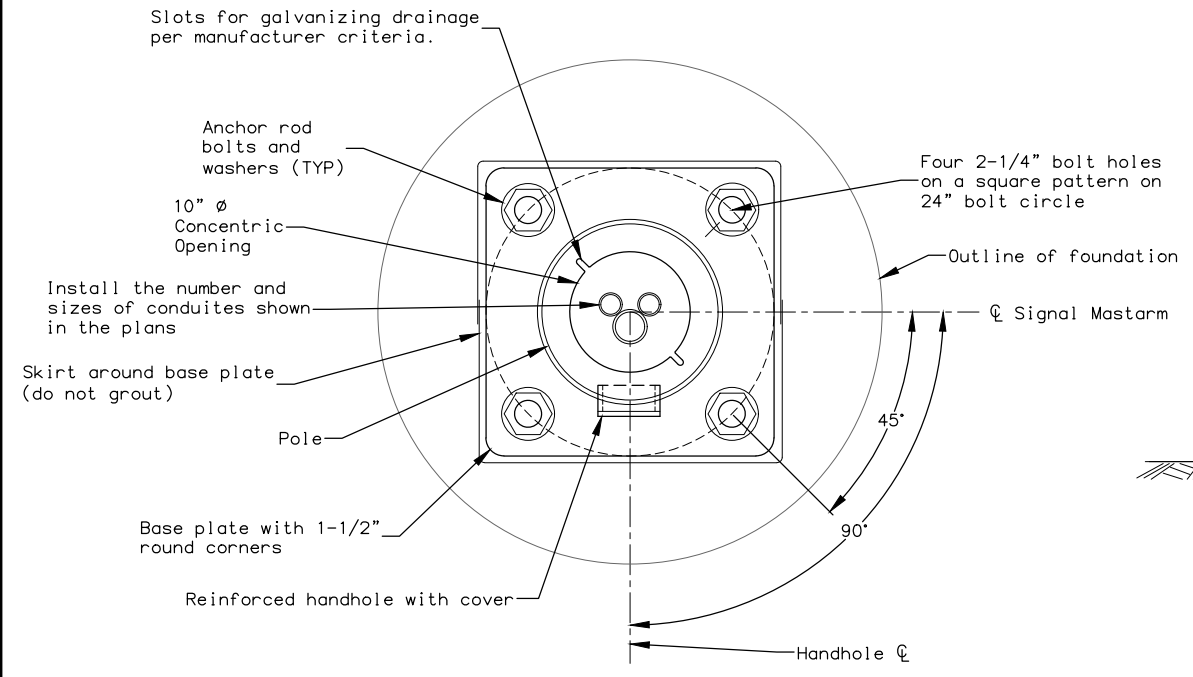

PLAN VIEW

(Shown without anchor bolts and nuts for clarity)

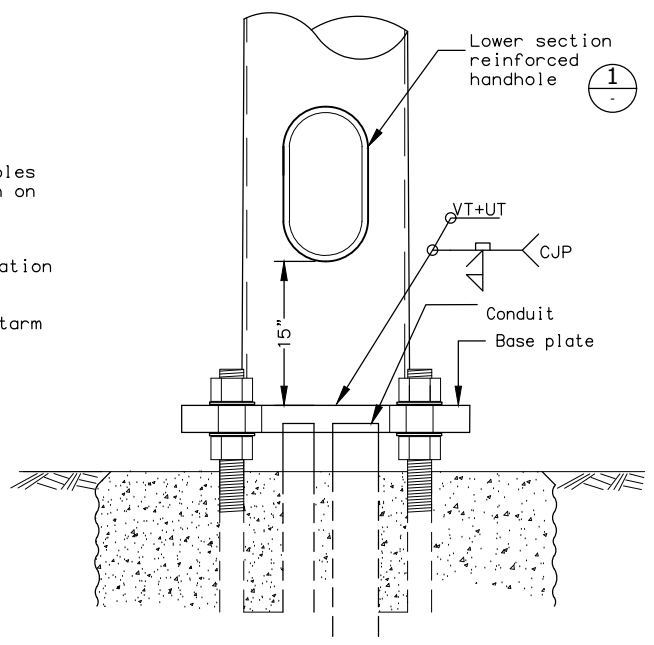

FRONT VIEW

(Skirt omitted for clarity)

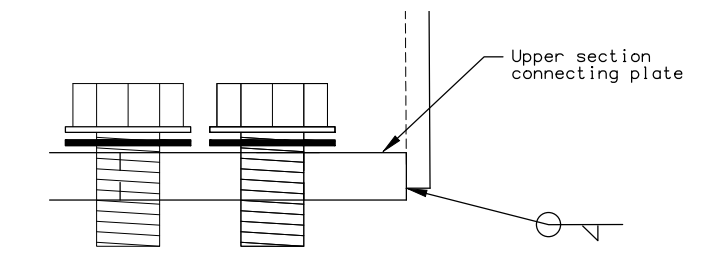

POST TOP UPPER SECTION CONNECTING PLATE

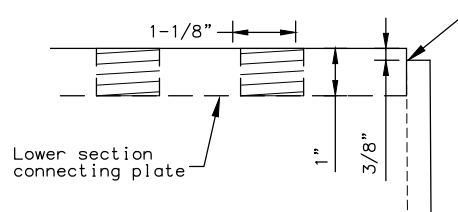

POST TOP LOWER SECTION CONNECTING PLATE

POLE BASE DETAILS
NTS

MATERIAL REQUIREMENTS	
MATERIAL QUALITY GUIDANCE	
Steel ≤ 1/2" Thick	ASTM A572 OR A595
Steel > 1/2" Thick	ASTM A709 (50ksi - Zone 3)
Finish	ASTM A123 & A153
Mastarm Bolts	ASTM F3125
Mastarm Washers	ASTM F436
Anchor Rods	See T-52
POLE (LOWER SECTION)	
Design Length	21.50'
Section Shape	Round
Simplex Height	20.0'
Taper	0.14'/ft
Diameter Bolt Circle	24.0"
Diameter Concentric Opening	10.0"
Tube Thickness	.375"
Fixed End Diameter	15.0" OD
Base Plate	24" x 24" x 2.25"
Backing Ring	0.25" x 3"
HANDHOLE DIMENSIONS	
Outside Dimensions	7" x 12.89"
Reinforcing Material	0.5" x 3"
Handhole Cover	0.125"
MISCELLANEOUS	
Post Top Connecting Plates	1.00"
Pole Skirt	0.125"
C-Hook	0.50"

State of Alaska DOT&PF
ALASKA STANDARD PLAN
SIGNAL POLE
WITH 15' TO 35' MASTARM
LOWER SECTION

Adopted as an Alaska Standard Plan by: *Carolyn Morehouse*
Carolyn Morehouse, P.E.
Chief Engineer

Adoption Date: 7/30/2021

Last Code and Stds. Review
By: Date: 5/13/2021

Next Code and Standards Review date: 5/13/2031

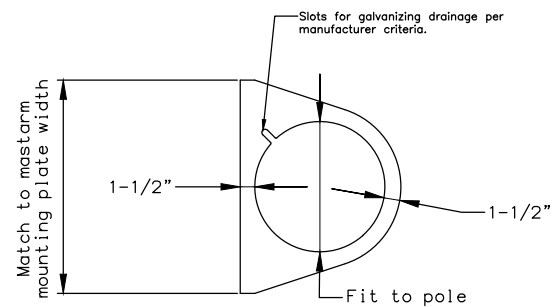

RING DETAIL

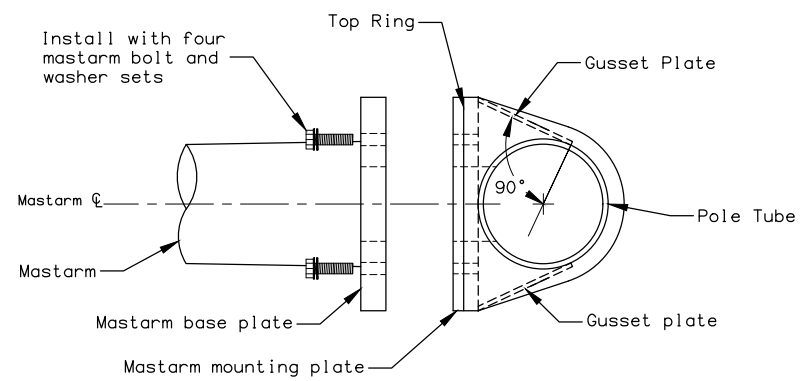

SECTION B-B

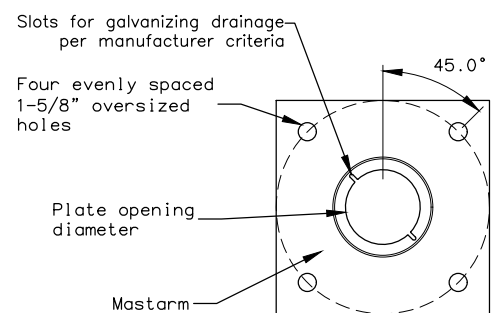

MASTARM BASE PLATE

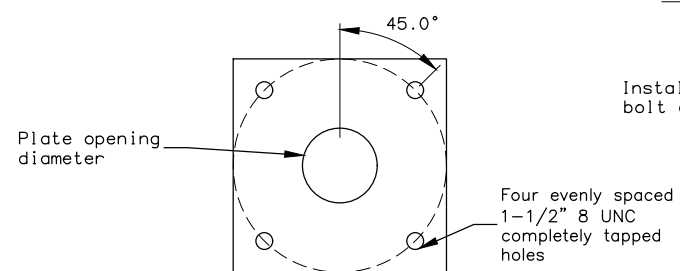

MASTARM MOUNTING PLATE

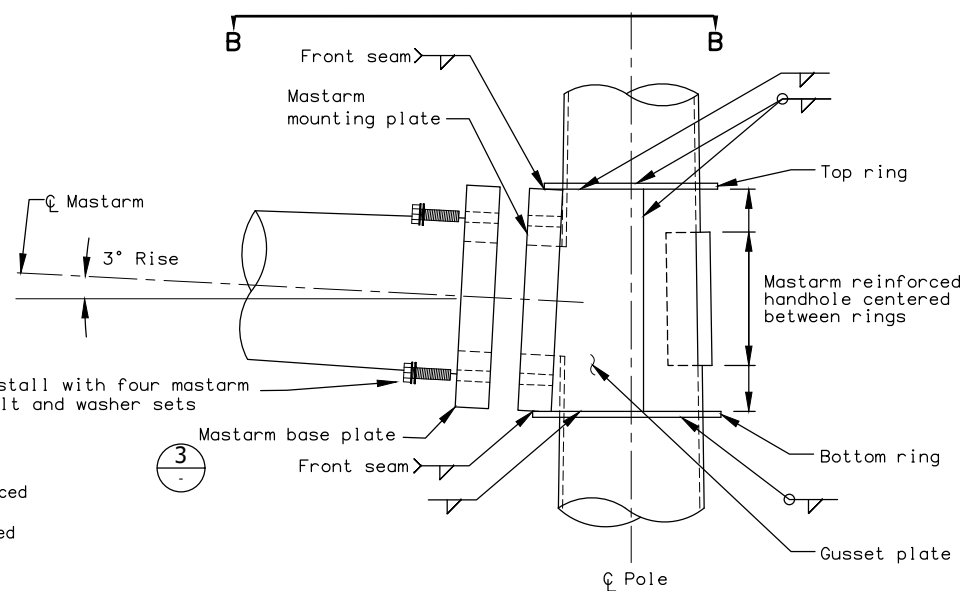

SIDE VIEW

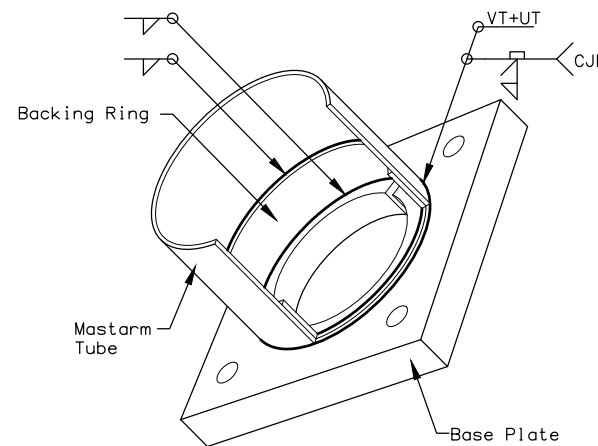

ISO VIEW

TUBE TO TRANSVERSE PLATE WELD DETAIL

(Shown with tube and backing ring cutout for clarity)

1 RING - STIFFENED BOX DETAILS
NTS

MATERIAL REQUIREMENTS	
MATERIAL QUALITY GUIDANCE	
Steel ≤ 1/2" Thick	ASTM A572 OR A595
Steel > 1/2" Thick	ASTM A709 (50ksi - Zone 3)
Finish	ASTM A123 & A153
Mastarm Bolts	ASTM F3125
Mastarm Washers	ASTM F436
Anchor Rods	See T-52
RING-STIFFENED BOX	
Mastarm Mounting Plate	20" x 20" x 2.25"
Plate Opening Diameter	Mastarm Data (See Sheet 1)
Top Ring Thickness	0.375"
Bottom Ring Thickness	0.375"
Gusset Plate Thickness	0.375"
MASTARM HANDHOLE	
Outside Dimensions	7" x 12.89"
Reinforcing Material	0.5" x 3"
Handhold Cover	0.125"
MASTARM	
Design Length	35'
Section Shape	Round
Taper	0.14"/ft
Bolt Circle Diameter	Mastarm Data (See Sheet 1)
Plate Opening Diameter	Mastarm Data (See Sheet 1)
Mastarm Tube Thickness	Mastarm Data (See Sheet 1)
Fixed End Diameter	Mastarm Data (See Sheet 1)
Mastarm Rise	3.0 Degrees
Mastarm Baseplate	20" x 20" x 3"
Backing Ring	0.25" x 3"
Mastarm Bolts	1.5" 6 UNC x 5.5"

State of Alaska DOT&PF
ALASKA STANDARD PLAN
SIGNAL POLE
WITH 15' TO 35' MASTARM
MASTARM & STIFFENED BOX

Adopted as an Alaska
Standard Plan by: *Carolyn Morehouse*
Carolyn Morehouse, P.E.
Chief Engineer

Adoption Date: 7/30/2021

Last Code and Stds. Review
By: Date: 5/13/2021

Next Code and Standards Review date: 5/13/2031

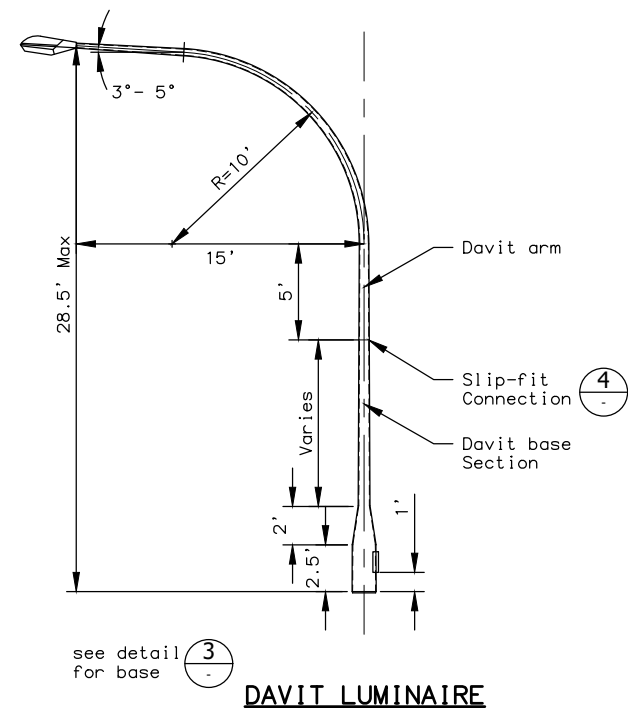
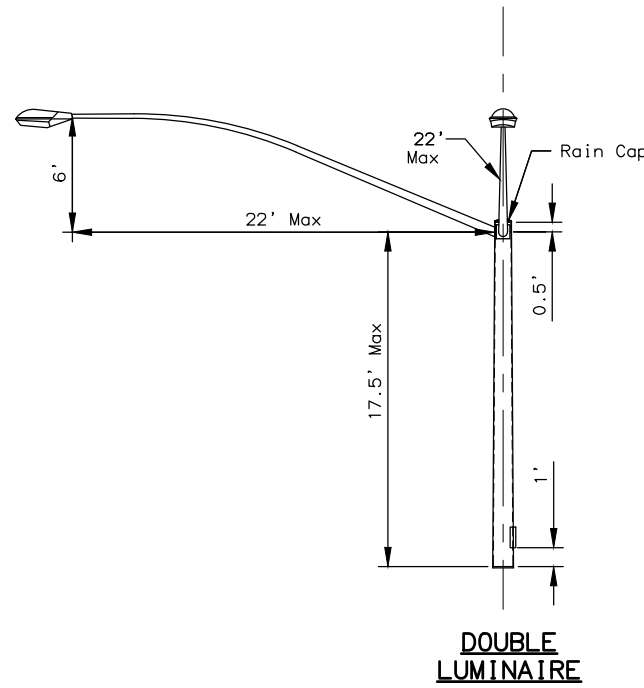
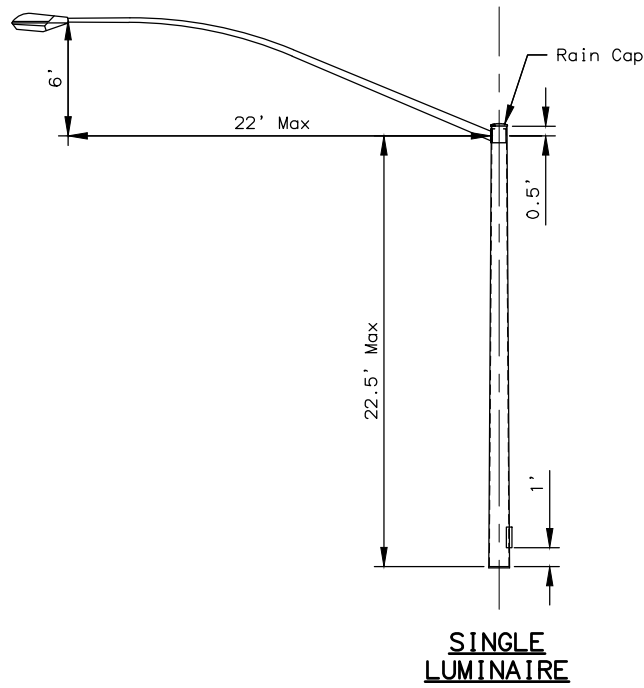

UPPER SECTION OPTIONS
NTS

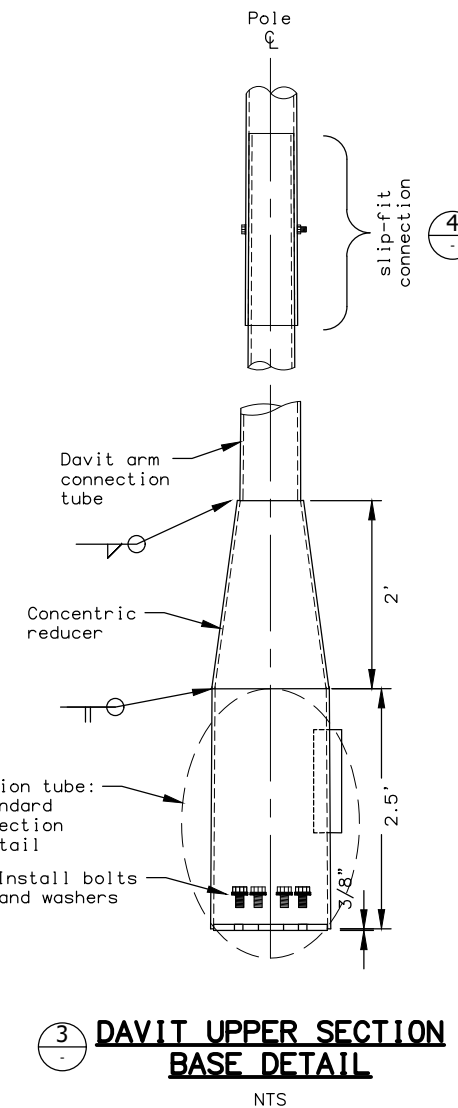
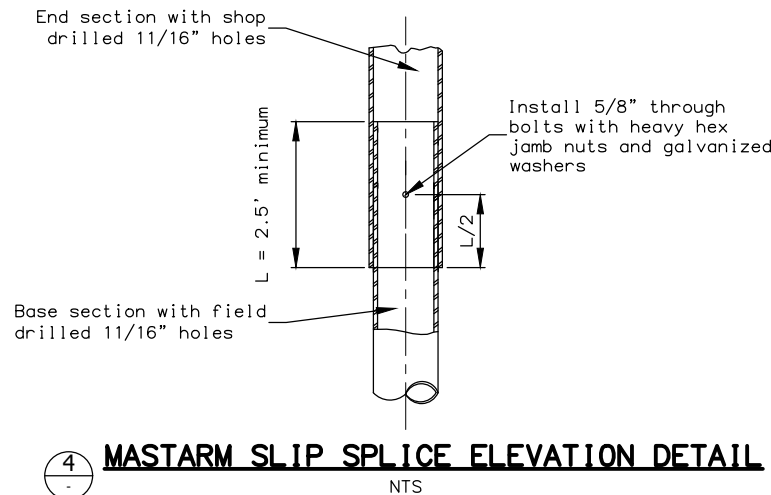
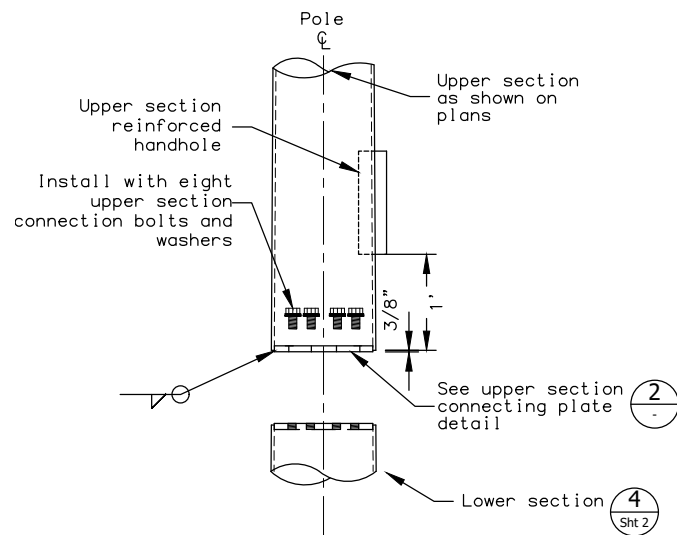

MATERIAL REQUIREMENTS	
MATERIAL QUALITY GUIDANCE	
Tube Material	A572, A595 GR A, or A1011 (50ksi min)
Post Top Connecting Plates	ASTM A709 (Zone 3)
Concentric Reducer	A572 OR A595 GR A
Connection Tube	A572 OR A595 GR A
Luminaire, Arm, and Mounting	See Lighting Standard Details
Upper Section Connection Bolts	ASTM F3125
Upper Section Connection Washers	ASTM F436
Slip Fit Through Bolt	ASTM F3125
Finish	ASTM A123 & A153
STANDARD UPPER SECTION	
Fixed End Diameter	11.99" O.D.
Taper	0.14"/ft
Connecting Plate Thickness	1"
Post Top Connection Bolts	1" 8 UNC x 2.75"
Tube Thickness	7 GA
HANDHOLE DIMENSIONS	
Upper Section Handhole	7" x 12.89"
Reinforcing Material	0.5" x 3"
Handhole Cover	0.125"
SINGLE LUMINAIRE	
Design Length	22.5'
Section Shape	Round
DOUBLE LUMINAIRE	
Design Length	17.5'
Section Shape	Round
DAVIT LUMINAIRE	
Design Length	28.5'
Section Shape	Round
Taper	0.14"/ft
Free End Diameter	2.375" O.D.
Connection Tube	7 GA
Concentric Reducer	7 GA
Davit Arm Connection Tube	7 GA
Davit Arm	7 GA

POST TOP STANDARD UPPER SECTION BASE DETAIL
(1)

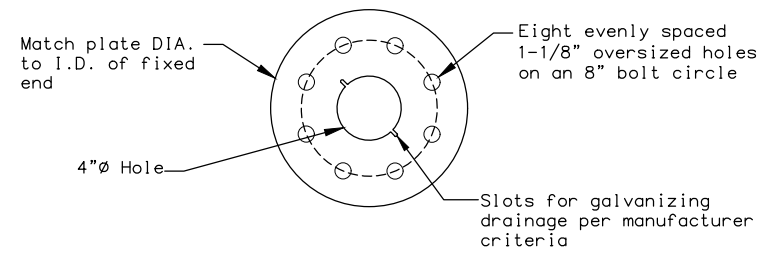

POST TOP CONNECTING PLATE DETAIL
(2)

MASTARM SLIP SPLICE ELEVATION DETAIL
(4) NTS

DAVIT UPPER SECTION BASE DETAIL
(3) NTS

State of Alaska DOT&PF
ALASKA STANDARD PLAN
SIGNAL POLE WITH 15' TO 35' MASTARM UPPER SECTION
Adopted as an Alaska Standard Plan by: *Carolyn Morehouse*
Carolyn Morehouse, P.E.
Chief Engineer
Adoption Date: 7/30/2021
Last Code and Stds. Review By: Date: 5/13/2021
Next Code and Standards Review date: 5/13/2031

POLE DESIGN LOADING						
Load Component	Height (ft.)	Weight (lbs.)	Ice Area (sq. ft.)	Wind Area (Face) (sq. ft.)	Wind Area (Side) (sq. ft.)	Fatigue Area (Bottom) (sq. ft.)
1 = Luminaire	0.5	25	8.1	0.6	1.0	2.5
2 = Signal	4.5	54	2.9	8.7	4.8	1.4
3 = Signal	5.6	70	37.5	11.0	6.4	1.4
4 = Ped Head	1.4	22	7.8	2.2	0.8	0.9
5 = Sign	2.5	120	69.7	30.0	0.8	4.0

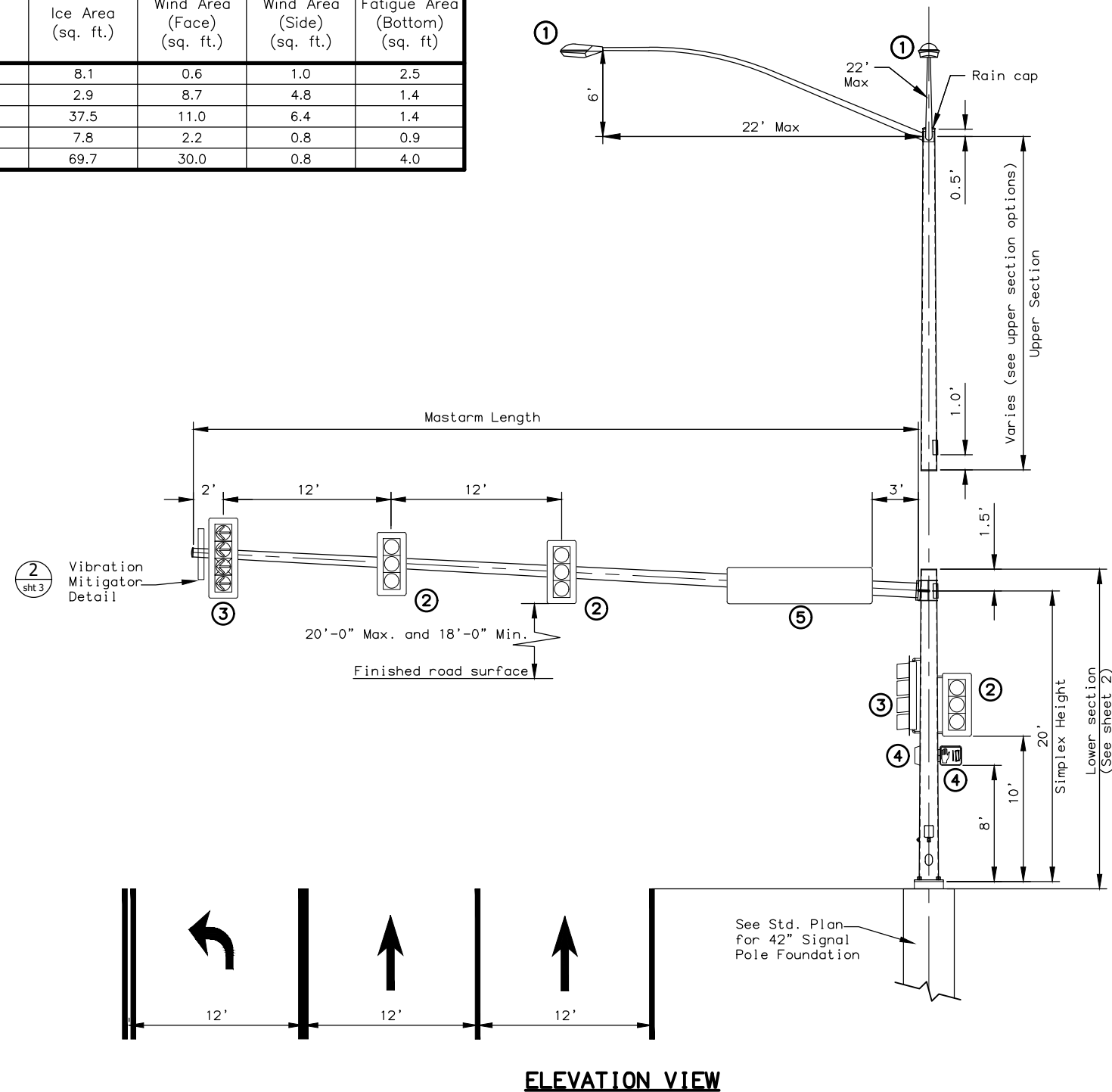

NOTES:

- Provide pole assemblies designed, manufactured and installed according to: 2013 AASHTO Standard Specifications for Structural Supports for Highway Signs, Luminaires and Traffic Signals with 2013 Errata and 2015 Interim Revision, the latest edition of the Alaska Standard Specifications for Highway Construction including standard modifications, and special provisions. Design structures for a 50-year Design Life, Fatigue Category I with ice loading, and with a basic wind speed of 100 mph. Fatigue design shall include Natural Wind Gust, Truck-Induced Gust, and an approved vibration mitigating device in lieu of Galloping effect.
- Provide poles to accommodate the maximum length shown in the mastarm data with the given loads, dimensions, and material requirements.
- This drawing shows loads (signs and signals) to be used by manufacturers when designing poles. It does not show actual loading of poles/mastarms on individual projects. This pole/mastarm design may be used without further analysis if the following conditions are met:
 - The guide sign (load #5) is attached to the mastarm base section and,
 - Not more than 5 traffic signals and/or signs are attached to the mastarm.
 If these conditions are not met, this standard pole/mastarm design may only be used if design computations are submitted that demonstrate conformance to design criteria (note 1) using actual loads. Devices with less than 1 square foot of projected area may be added to the mastarm without causing a need for additional design computations.
- The manufacturer is to determine weld sizes. All welds and testing shall conform to the latest edition of the structural welding code AWS D1.1. Provide visual testing (VT) of 100% of all welds. Provide magnetic particle testing (MT) of 100% of all fillet welds. Provide radiographic (RT) or ultrasonic testing (UT) of 100% of all complete joint penetration welds and a random 25% of all partial joint penetration longitudinal seam welds.
- Fabricate pole tubes and mastarm tubes from no more than 2 pieces of steel. When using 2 pieces, place the longitudinal welded seams directly opposite one another. Transverse weld seams prohibited.
- Fabricate luminaire arms and connections according to the latest lighting standard detail.
- Provide permanent tags on all pole sections per section 740 table 740-1 of the specifications. Provide a weather proof rain cap on all exposed sections of the structure.
- The Department will reject damaged or defective poles for any of the following: variances from approved shop drawings, variances from material requirements, sections more than 2-percent out of round, flanged mounting surfaces with flatness variation greater than 0.030", sections bowed more than 1-inch throughout the length of the pole, mastarm, or segment, and damaged or dented finishes.
- To allow for wiring, field drill a 1" maximum diameter hole at each traffic signal head location. Orient the hole on the horizontal axis of mastarms.
- Install pole raked outward from plumb position in the direction opposite the mastarm such that the side of the pole opposite the mastarm is vertical.
- Clean and remove dirt, burrs, mill scale, and excess galvanization on all faying surfaces and threaded parts before assembly. Lubricate the threads of all bolts and nuts with lubricant containing a visible dye. Tighten all bolts according to section 504 of the specifications.

MASTARM DATA										
MASTARM		MASTARM END SECTION			MASTARM BASE SECTION			MASTARM BASEPLATE		
Length (ft.)	Maximum Allowed Galloping Deflection (in.)	Free End Diameter (in.)	Length (ft.)	Tube Thickness (in.)	Length (ft.)	Fixed End Diameter* (in.)	Tube Thickness (in.)	Plate Opening Diameter (in.)	Bolt Circle Diameter (in.)	Plate Thickness (in.)
40	8.0	7.25	25.0	0.1793	18.34	12.5	0.3125	10.0	22.0	2.25
45	8.0	7.25	25.0	0.1793	23.34	13.2	0.3125	10.0	22.0	2.25
50	8.0	7.25	25.0	0.1793	28.34	13.9	0.3125	10.0	22.0	2.25

*Fixed end diameter measured at connection to Baseplate

State of Alaska DOT&PF
ALASKA STANDARD PLAN
SIGNAL POLE
WITH 40' TO 50' MASTARM
LOADING & NOTES

Adopted as an Alaska Standard Plan by: *Carolyn Morehouse*
Carolyn Morehouse, P.E.
Chief Engineer

Adoption Date: 7/30/2021

Last Code and Stds. Review
By: Date: 5/13/2021

Next Code and Standards Review date: 5/13/2031

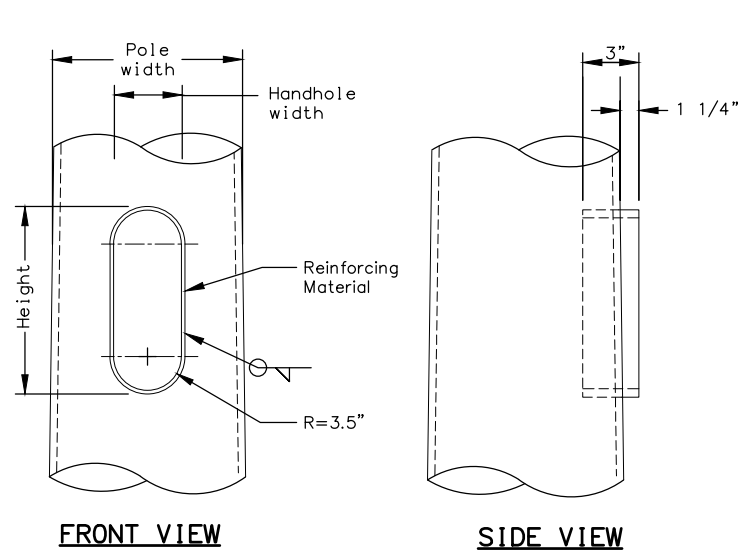

1
REINFORCED HANDHOLE DETAILS
(See material requirements table for dimensions)
NTS

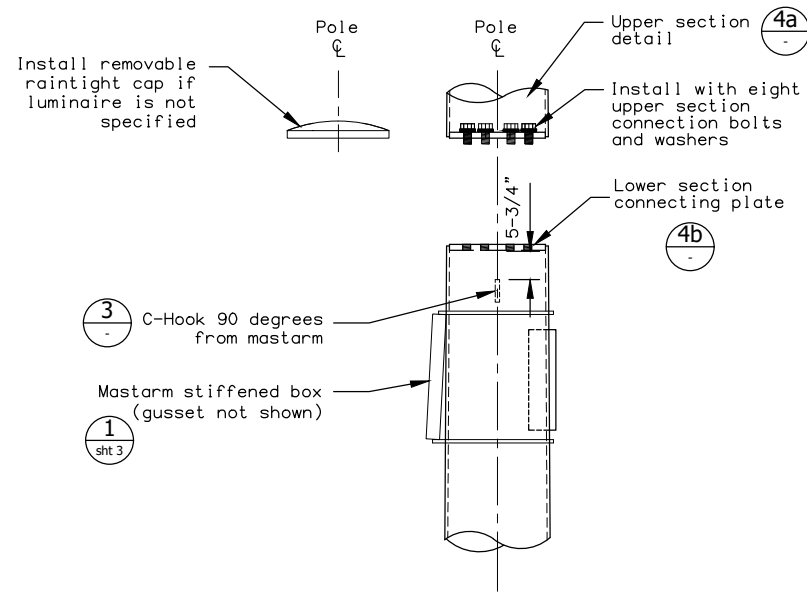

4
LOWER SECTION POST TOP DETAIL

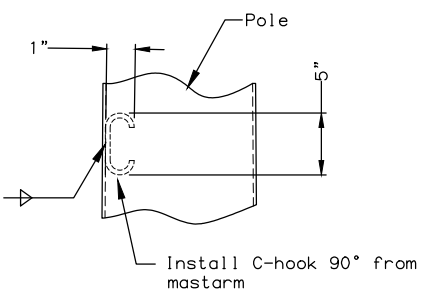
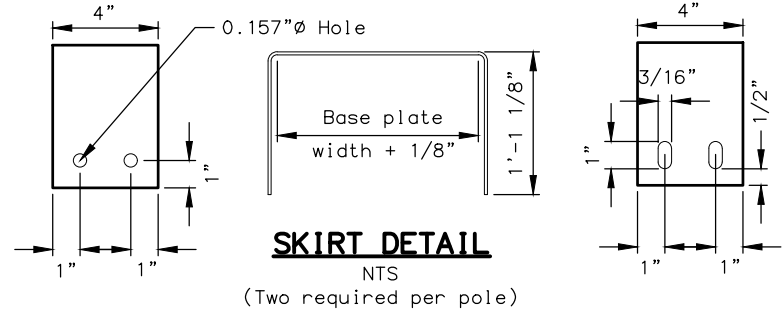

3
C-HOOK DETAIL
(Typical throughout lower section)
NTS

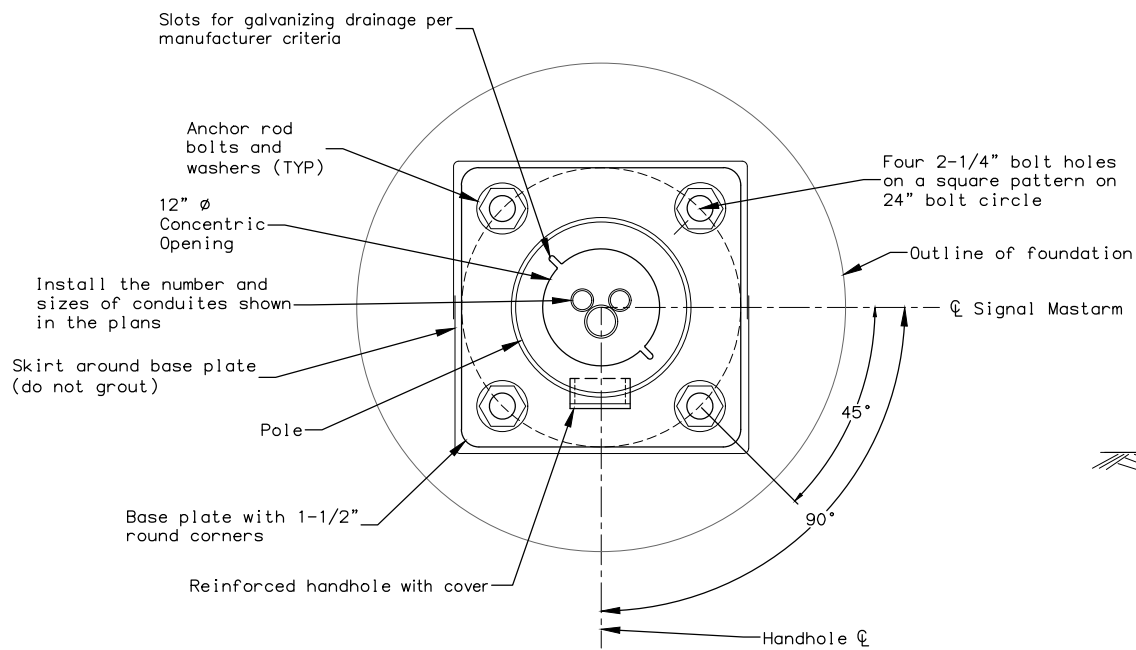

5
POLE BASE DETAILS
(Shown without anchor bolts and nuts for clarity)
NTS

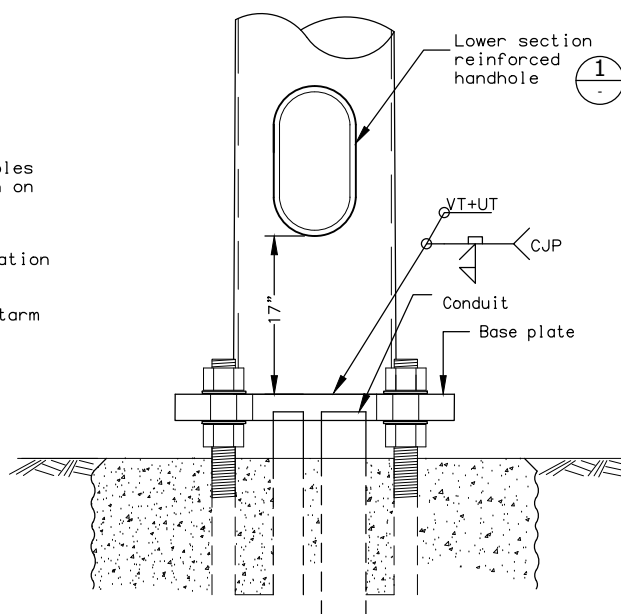

2
FRONT VIEW
(Skirt omitted for clarity)
NTS

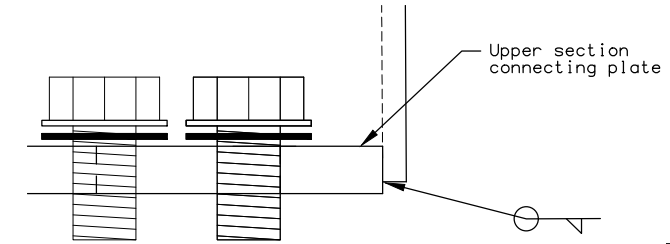

4a
POST TOP UPPER SECTION CONNECTING PLATE

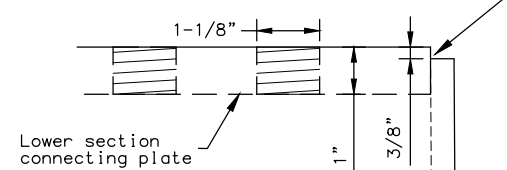

4b
POST TOP LOWER SECTION CONNECTING PLATE

MATERIAL REQUIREMENTS	
MATERIAL QUALITY GUIDANCE	
Steel ≤ 1/2" Thick	ASTM A572 OR A595
Steel > 1/2" Thick	ASTM A709 (50ksi - Zone 3)
Finish	ASTM A123 & A153
Mastarm Bolts	ASTM F3125
Mastarm Washers	ASTM F436
Anchor Rods	See T-52
POLE (LOWER SECTION)	
Design Length	21.50'
Section Shape	Round
Simplex Height	20.0'
Taper	0.14'/ft
Baseplate Bolt Circle Diameter	24.0"
Diameter Concentric Opening	12.0"
Tube Thickness	0.375"
Fixed End Diameter	17.0" OD
Base Plate	24" x 24" x 2.25"
Backing Ring	0.25" x 3"
HANDHOLE DIMENSIONS	
Outside Dimensions	7" x 12.89"
Reinforcing Material	0.5" x 3"
Handhole Cover	0.125"
MISCELLANEOUS	
Post Top Connecting Plates	1.00"
Pole Skirt	0.125"
C-Hook	0.50"

State of Alaska DOT&PF
ALASKA STANDARD PLAN
SIGNAL POLE
WITH 40' TO 50' MASTARM
LOWER SECTION

Adopted as an Alaska Standard Plan by: *Carolyn Morehouse*
Carolyn Morehouse, P.E.
Chief Engineer

Adoption Date: 7/30/2021

Last Code and Stds. Review By: Date: 5/13/2021

Next Code and Standards Review date: 5/13/2031

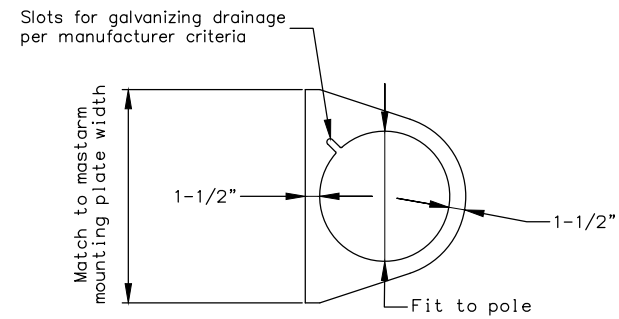

RING DETAIL

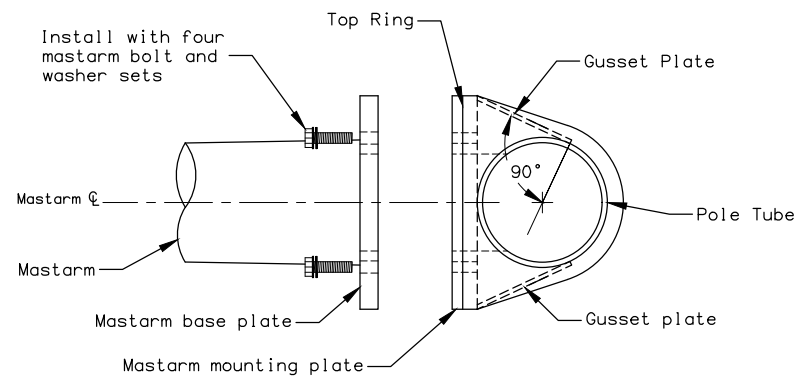

SECTION B-B

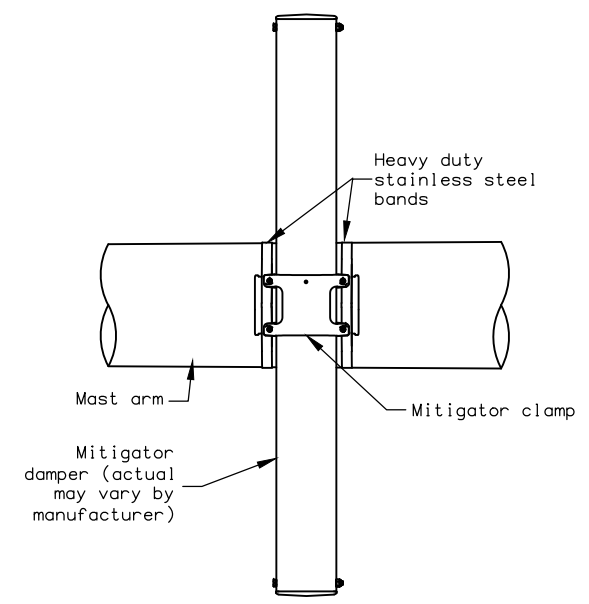

VIBRATION MITIGATOR CONNECTION DETAIL

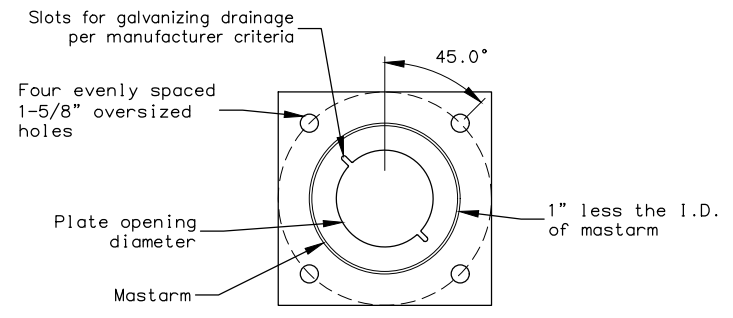

MASTARM BASE PLATE

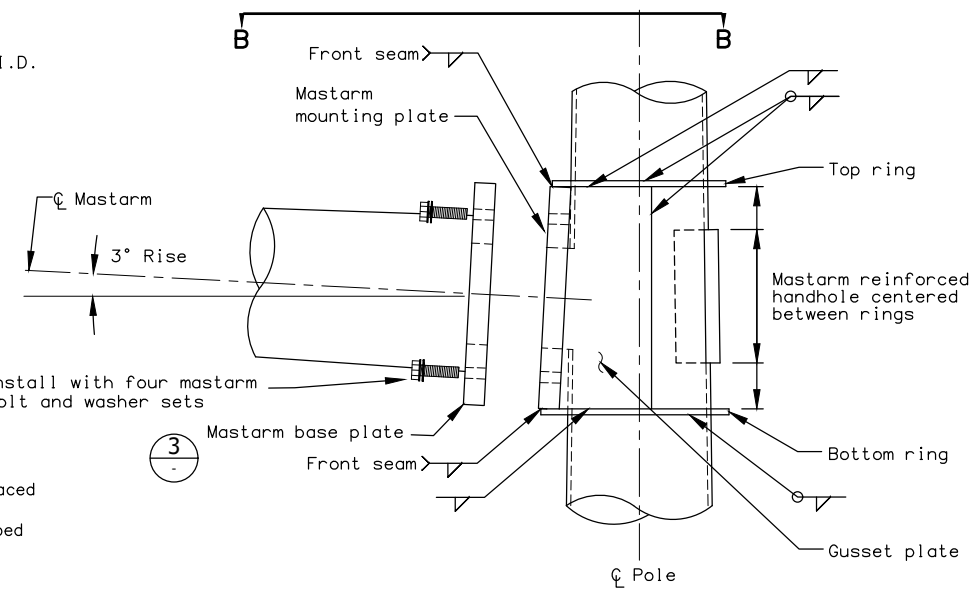

SIDE VIEW

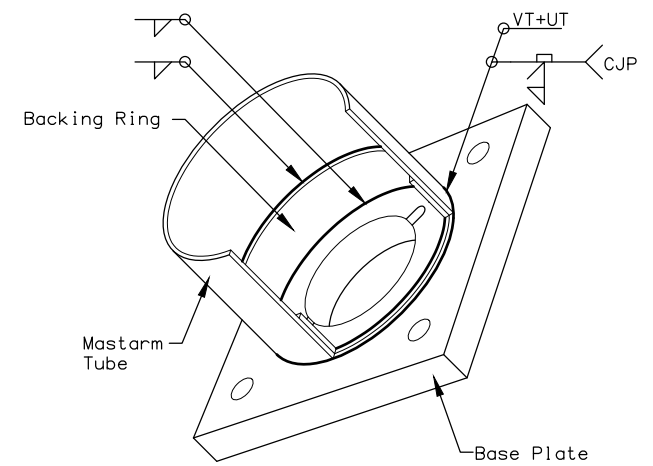

ISO VIEW TUBE TO TRANSVERSE PLATE WELD DETAIL
(Shown with tube and backing ring cutout for clarity)

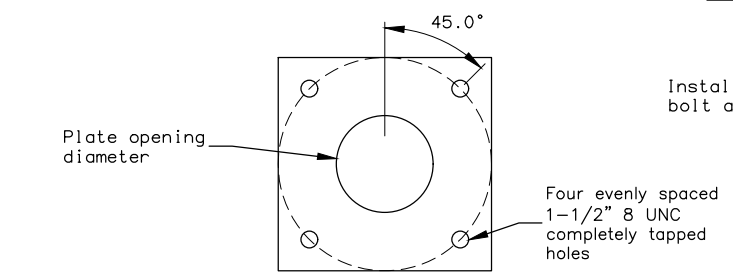

MASTARM MOUNTING PLATE

RING - STIFFENED BOX DETAILS
NTS

MATERIAL REQUIREMENTS	
MATERIAL QUALITY GUIDANCE	
Steel ≤ 1/2" Thick	ASTM A572 OR A595
Steel > 1/2" Thick	ASTM A709 (50ksi - Zone 3)
Finish	ASTM A123 & A153
Mastarm Bolts	ASTM F3125
Mastarm Washers	ASTM F436
Anchor Rods	See T-52
RING-STIFFENED BOX	
Mastarm Mounting Plate	22" x 22" x 2.25"
Plate Opening Diameter	Mastarm Data (See Sheet 1)
Top Ring Thickness	0.375"
Bottom Ring Thickness	0.375"
Gusset Plate Thickness	0.375"
MASTARM HANDHOLE	
Outside Dimensions	7" x 12.89"
Reinforcing Material	0.5" x 3"
Handhold Cover	0.125"
MASTARM	
Design Length	50'
Section Shape	Round
Bolt Circle Diameter	Mastarm Data (See Sheet 1)
Plate Opening Diameter	Mastarm Data (See Sheet 1)
Mastarm Tube Thickness	Mastarm Data (See Sheet 1)
Fixed End Diameter	Mastarm Data (See Sheet 1)
Mastarm Rise	3.0 Degrees
Mastarm Baseplate	22" x 22" x 2.25"
Backing Ring	0.25" x 3"
Mastarm Bolts	1.5" 6 UNC x 5.5"

State of Alaska DOT&PF
ALASKA STANDARD PLAN
SIGNAL POLE
WITH 40' TO 50' MASTARM
MASTARM & STIFFENED BOX

Adopted as an Alaska Standard Plan by: *Carolyn Morehouse*
Carolyn Morehouse, P.E.
Chief Engineer

Adoption Date: 7/30/2021

Last Code and Stds. Review
By: Date: 5/13/2021

Next Code and Standards Review date: 5/13/2031

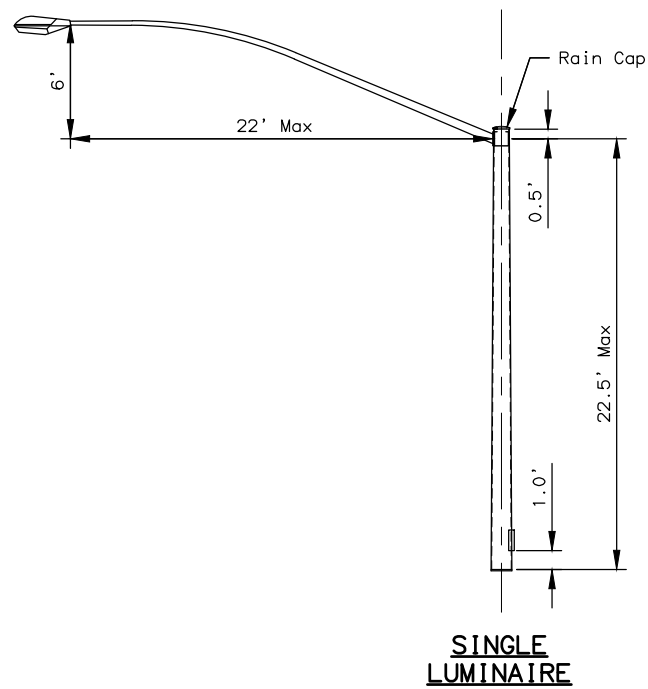

SINGLE LUMINAIRE

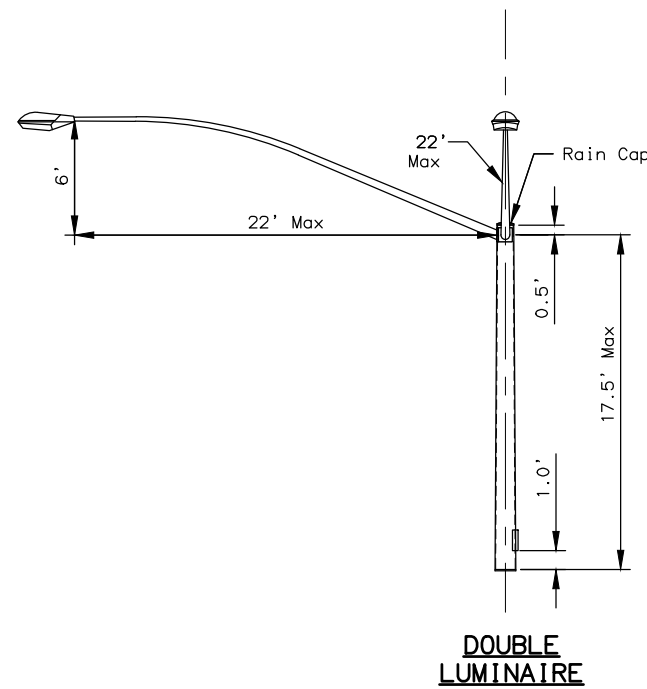

DOUBLE LUMINAIRE

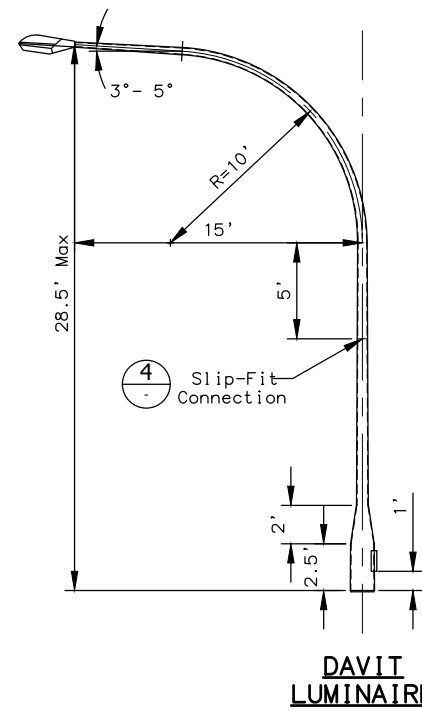

DAVIT LUMINAIRE

UPPER SECTION OPTIONS

NTS

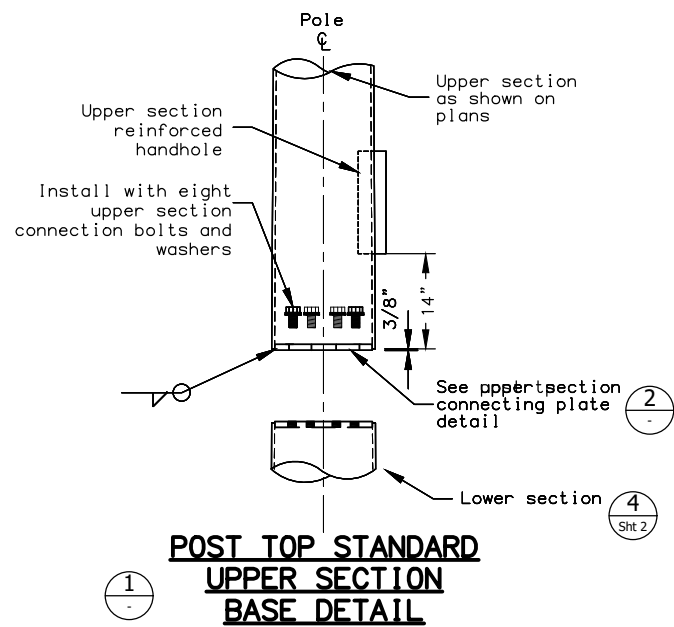

POST TOP STANDARD UPPER SECTION BASE DETAIL

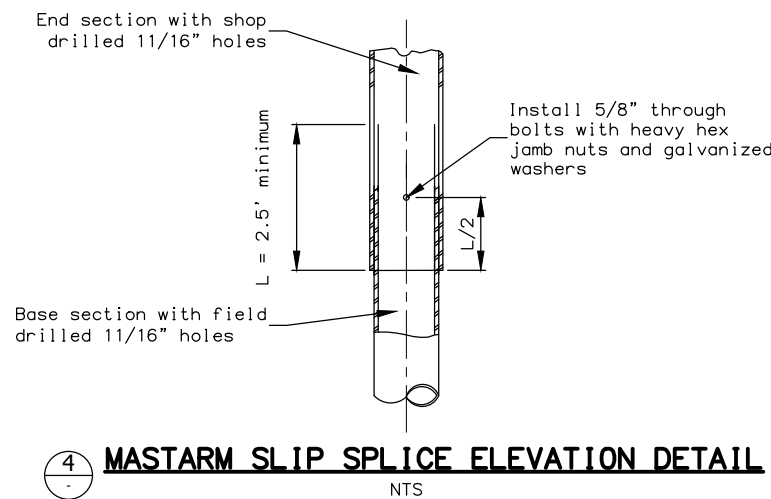

MASTARM SLIP SPLICE ELEVATION DETAIL

NTS

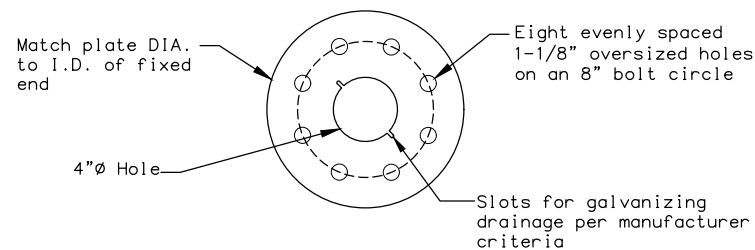

POST TOP CONNECTING PLATE DETAIL

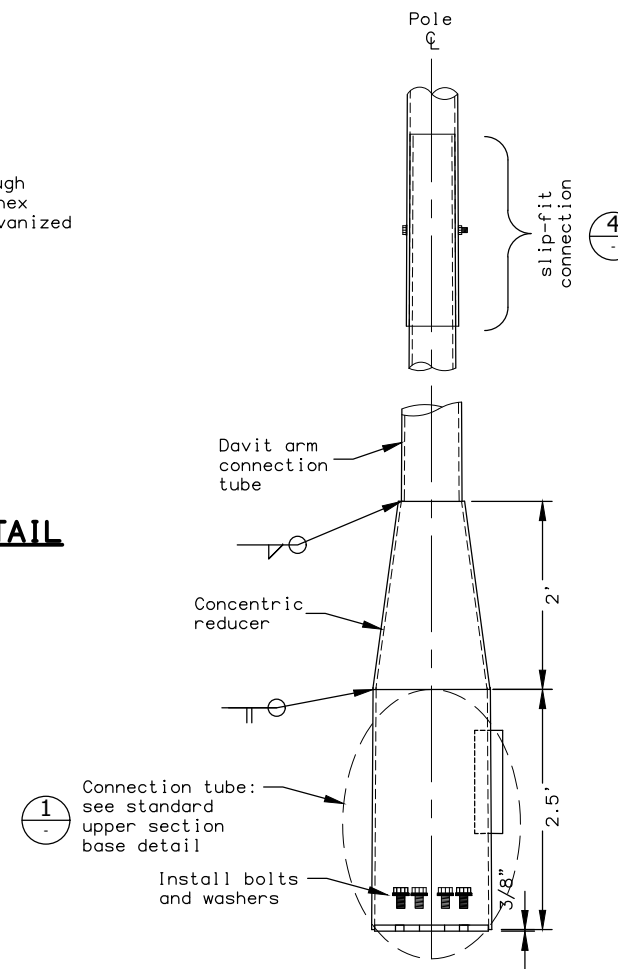

DAVIT UPPER SECTION BASE DETAIL

NTS

MATERIAL REQUIREMENTS	
MATERIAL QUALITY GUIDANCE	
Tube Material	A572, A595 GR A, or A1011 (50ksi min)
Post Top Connecting Plates	ASTM A709 (Zone 3)
Concentric Reducer	A572 OR A595 GR A
Connection Tube	A572 OR A595 GR A
Luminaire, Arm, and Mounting	See Lighting Standard Details
Upper Section Connection Bolts	ASTM F3125
Upper Section Connection Washers	ASTM F436
Slip Fit Through Bolt	ASTM F3125
Finish	ASTM A123 & A153
STANDARD UPPER SECTION	
Fixed End Diameter	13.99" O.D.
Taper	0.14"/ft
Connecting Plate Thickness	1"
Post Top Connection Bolts	1" 8 UNC x 2.75"
Tube Thickness	7 GA
HANDHOLE DIMENSIONS	
Upper Section Handhole	7" x 12.89"
Reinforcing Material	0.5" x 3"
Handhole Cover	0.125"
SINGLE LUMINAIRE	
Design Length	22.5'
Section Shape	Round
DOUBLE LUMINAIRE	
Design Length	17.5'
Section Shape	Round
DAVIT LUMINAIRE	
Design Length	28.5'
Section Shape	Round
Taper	0.14"/ft
Free End Diameter	2.375" O.D.
Connection Tube	7 GA
Concentric Reducer	7 GA
Davit Arm Connection Tube	7 GA
Davit Arm	7 GA

State of Alaska DOT&PF
ALASKA STANDARD PLAN
SIGNAL POLE WITH 40' TO 50' MASTARM UPPER SECTION
Adopted as an Alaska Standard Plan by: *Carolyn Morehouse*
Carolyn Morehouse, P.E.
Chief Engineer

Adoption Date: 7/30/2021

Last Code and Stds. Review By: Date: 5/13/2021

Next Code and Standards Review date: 5/13/2031

POLE DESIGN LOADING						
Load Component	Height (ft.)	Weight (lbs.)	Ice Area (sq. ft.)	Wind Area (Face) (sq. ft.)	Wind Area (Side) (sq. ft.)	Fatigue Area (Bottom) (sq. ft.)
1 = Luminaire	0.5	25	8.1	0.6	1.0	2.5
2 = Signal	4.5	54	2.9	8.7	4.8	1.4
3 = Signal	5.6	70	37.5	11.0	6.4	1.4
4 = Ped Head	1.4	22	7.8	2.2	0.8	0.9
5 = Sign	2.5	120	69.7	30.0	0.8	4.0

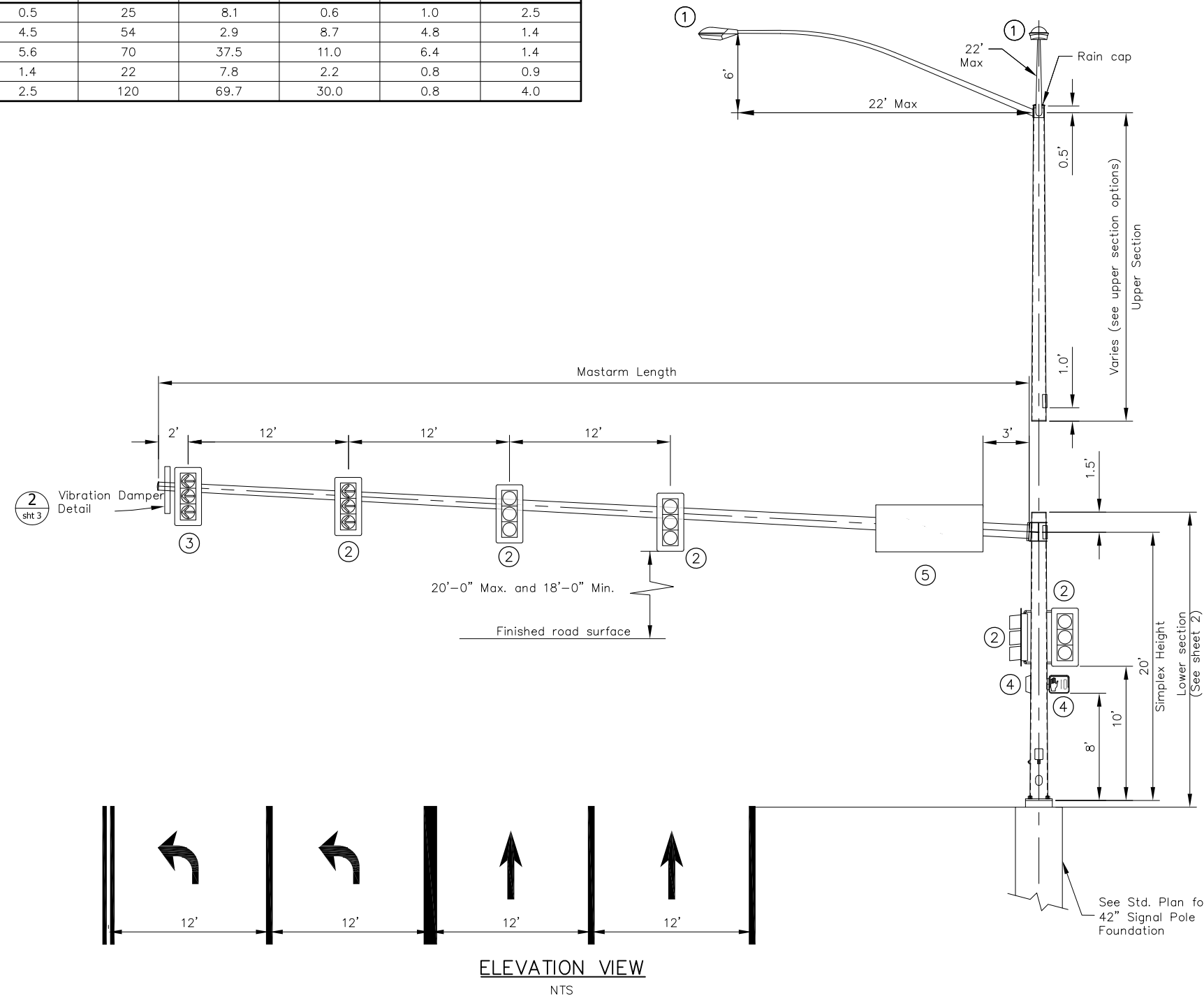

NOTES:

- Provide pole assemblies designed, manufactured and installed according to: 2013 AASHTO Standard Specifications for Structural Supports for Highway Signs, Luminaires and Traffic Signals with 2013 Errata and 2015 Interim Revision, the latest edition of the Alaska Standard Specifications for Highway Construction including standard modifications, and special provisions. Design structures for a 50-year Design Life, Fatigue Category I with ice loading, and with a basic wind speed of 100 mph. Fatigue design shall include Natural Wind Gust, Truck-Induced Gust, and an approved vibration mitigating device in lieu of Galloping effect.
- Provide poles to accommodate the maximum length shown in the mastarm data with the given loads, dimensions, and material requirements.
- This drawing shows loads (signs and signals) to be used by manufacturers when designing poles. It does not show actual loading of poles/mastarms on individual projects. This pole/mastarm design may be used without further analysis if the following conditions are met:
 - The guide sign (load #5) is attached to the mastarm base section and,
 - Not more than 5 traffic signals and/or signs are attached to the mastarm.
 If these conditions are not met, this standard pole/mastarm design may only be used if design computations are submitted that demonstrate conformance to design criteria (note 1) using actual loads. Devices with less than 1 square foot of projected area may be added to the mastarm without causing a need for additional design computations.
- The manufacturer is to determine weld sizes. All welds and testing shall conform to the latest edition of the structural welding code AWS D1.1. Provide visual testing (VT) of 100% of all welds. Provide magnetic particle testing (MT) of 100% of all fillet welds. Provide radiographic (RT) or ultrasonic testing (UT) of 100% of all complete joint penetration welds and a random 25% of all partial joint penetration longitudinal seam welds.
- Fabricate pole tubes and mastarm tubes from no more than 2 pieces of steel. When using 2 pieces, place the longitudinal welded seams directly opposite one another. Transverse weld seams prohibited.
- Fabricate luminaire arms and connections according to the latest lighting standard detail.
- Provide permanent tags on all pole sections per section 740 table 740-1 of the specifications. Provide a weather proof rain cap on all exposed sections of the structure.
- The Department will reject damaged or defective poles for any of the following: variances from approved shop drawings, variances from material requirements, sections more than 2-percent out of round, flanged mounting surfaces with flatness variation greater than 0.030", sections bowed more than 1-inch throughout the length of the pole, mastarm, or segment, and damaged or dented finishes.
- To allow for wiring, field drill a 1" maximum diameter hole at each traffic signal head location. Orient the hole on the horizontal axis of mastarms.
- Install pole raked outward from plumb position in the direction opposite the mastarm such that the side of the pole opposite the mastarm is vertical.
- Clean and remove dirt, burrs, mill scale, and excess galvanization on all faying surfaces and threaded parts before assembly. Lubricate the threads of all bolts and nuts with lubricant containing a visible dye. Tighten all bolts according to section 504 of the specifications.

MASTARM DATA									
MASTARM		MASTARM END SECTION			MASTARM BASE SECTION			MASTARM BASEPLATE	
Length (ft.)	Maximum Allowed Galloping Deflection (in.)	Free End Diameter (in.)	Length (ft.)	Tube Thickness (in.)	Length (ft.)	Fixed End Diameter* (in.)	Tube Thickness (in.)	Plate Opening Diameter (in.)	Plate Thickness (in.)
55	10.0	7.25	25.0	0.1793	33.34	14.6	0.375	10.0	2.25
60	10.0	7.25	25.0	0.1793	38.34	15.3	0.375	10.0	2.25
65	10.0	7.25	25.0	0.1793	43.34	16.0	0.375	10.0	2.25

*Fixed end diameter measured at connection to Baseplate

State of Alaska DOT&PF
ALASKA STANDARD PLAN

**SIGNAL POLE
WITH 55' TO 65' MASTARM
LOADING & NOTES**

Adopted as an Alaska Standard Plan by: *Carolyn H Morehouse*
Carolyn Morehouse, P.E.
Chief Engineer

Adoption Date: 9/15/2022

Last Code and Stds. Review
By: Date: 5/13/2021

Next Code and Standards Review date: 5/13/2031

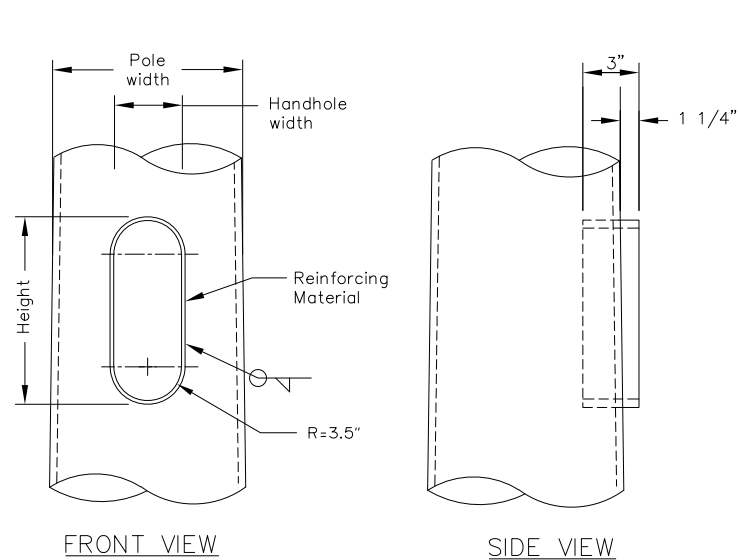

1
REINFORCED HANDHOLE DETAILS
(See material requirements table for dimensions)
NTS

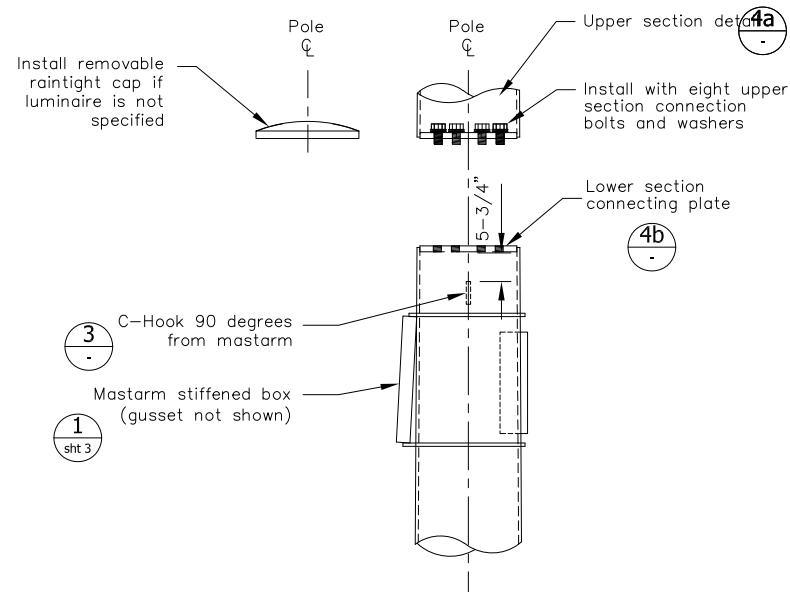

4
LOWER SECTION POST TOP DETAIL

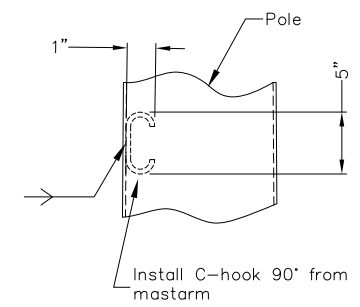

3
C-HOOK DETAIL
(Typical throughout lower section)
NTS

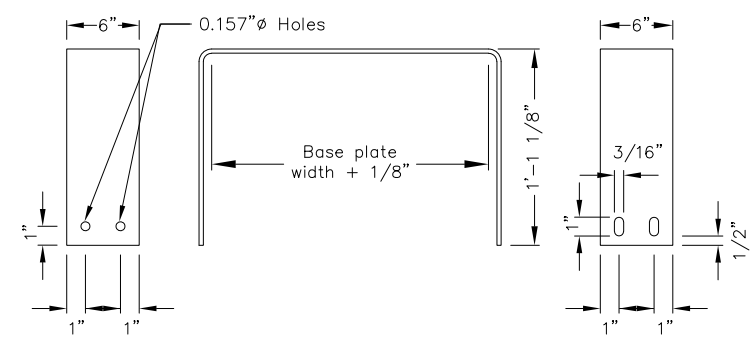

2
SKIRT DETAIL
NTS
(Two required per pole)

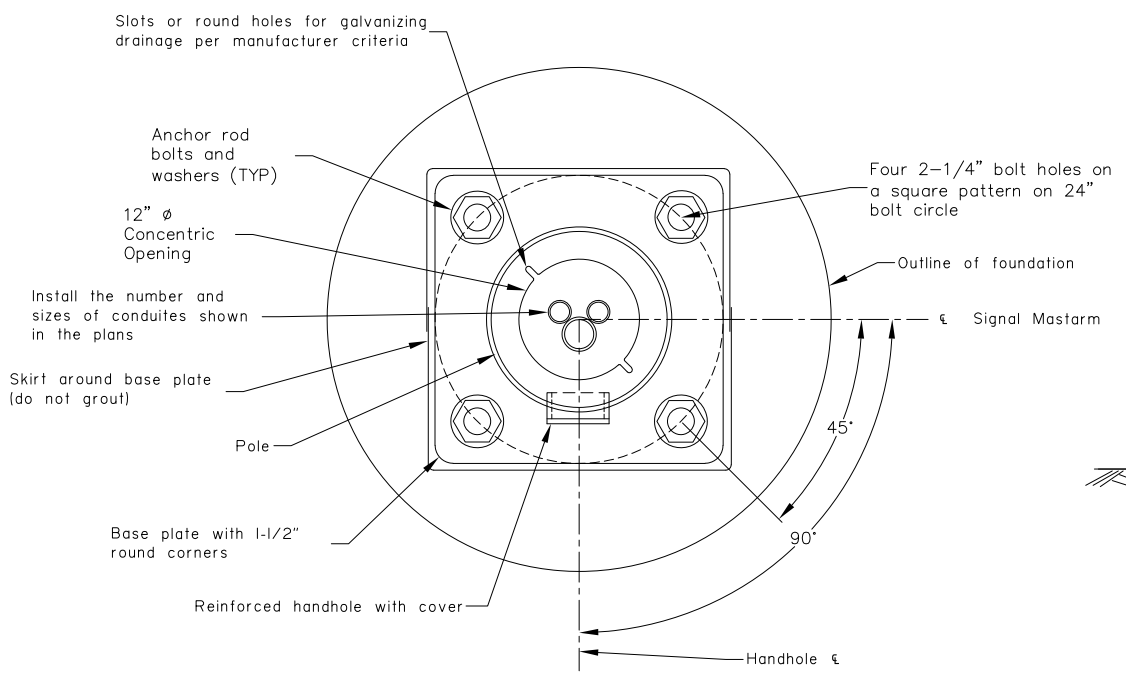

5
POLE BASE DETAILS
NTS

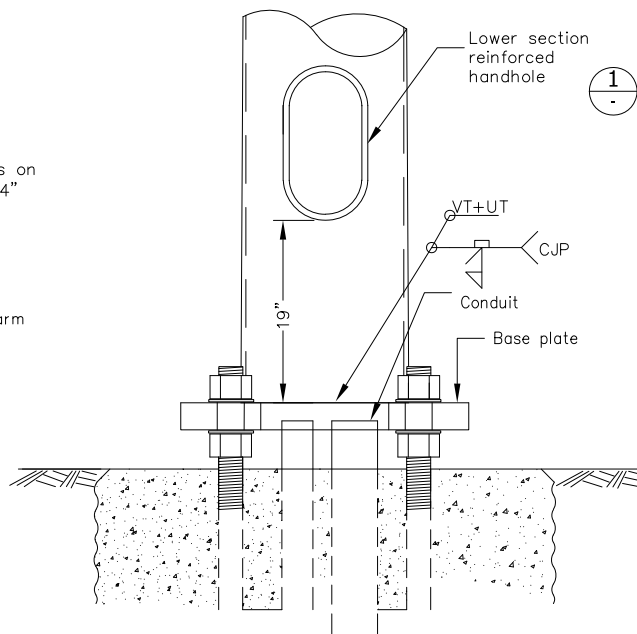

2
FRONT VIEW
(Skirt omitted for clarity)

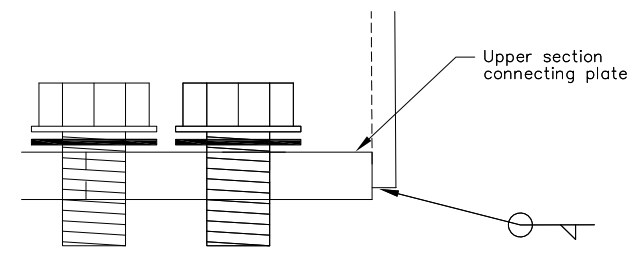

4a
POST TOP UPPER SECTION CONNECTING PLATE

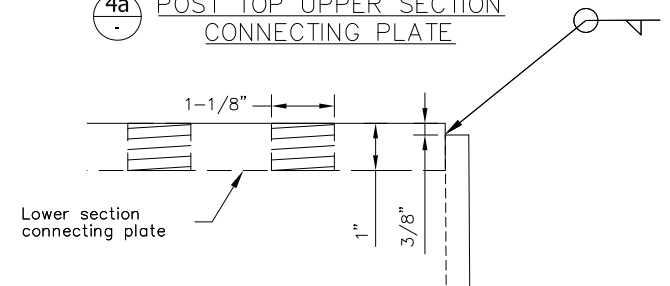

4b
POST TOP LOWER SECTION CONNECTING PLATE

MATERIAL REQUIREMENTS	
MATERIAL QUALITY GUIDANCE	
Steel ≤ 1/2" Thick	ASTM A572 OR A595
Steel > 1/2" Thick	ASTM A709 (50ksi - Zone 3)
Finish	ASTM A123 & A153
Mastarm Bolts	ASTM F3125
Mastarm Washers	ASTM F436
Anchor Rods	See T-52
POLE (LOWER SECTION)	
Design Length	21.50'
Section Shape	Round
Simplex Height	20.0'
Taper	0.14"/ft
Baseplate Bolt Circle Diameter	24.0"
Diameter Concentric Opening	12.0"
Tube Thickness	0.375"
Fixed End Diameter	19.0" OD
Base Plate	24" x 24" x 2.25"
Backing Ring	0.25" x 3"
HANDHOLE DIMENSIONS	
Outside Dimensions	7" x 12.89"
Reinforcing Material	0.5" x 3"
Handhole Cover	0.125"
MISCELLANEOUS	
Post Top Connecting Plates	1.00"
Pole Skirt	0.125"
C-Hook	0.50"

State of Alaska DOT&PF
ALASKA STANDARD PLAN
**SIGNAL POLE
WITH 55' TO 65' MASTARM
LOWER SECTION**

Adopted as an Alaska Standard Plan by *Carolyn H. Morehouse*
Carolyn Morehouse, P.E.
Chief Engineer

Adoption Date: 9/15/2022

Last Code and Stds. Review
By: Date: 5/13/2021

Next Code and Standards Review date: 5/13/2031

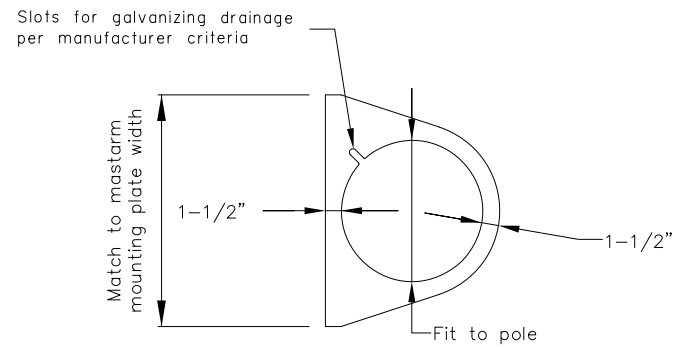

RING DETAIL

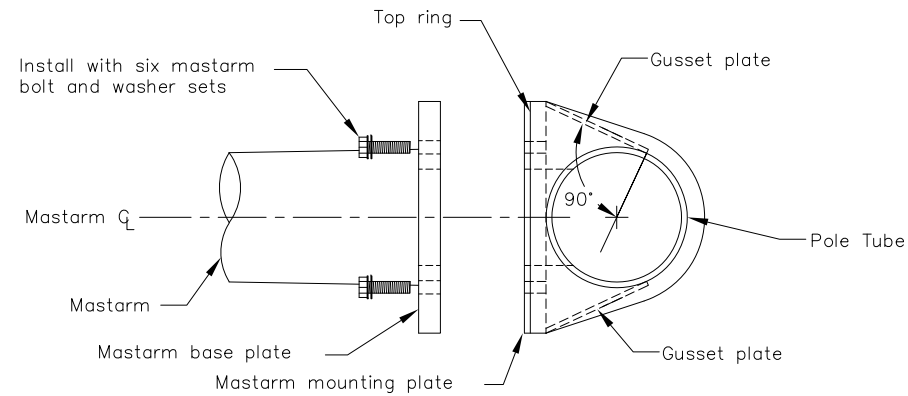

SECTION B-B

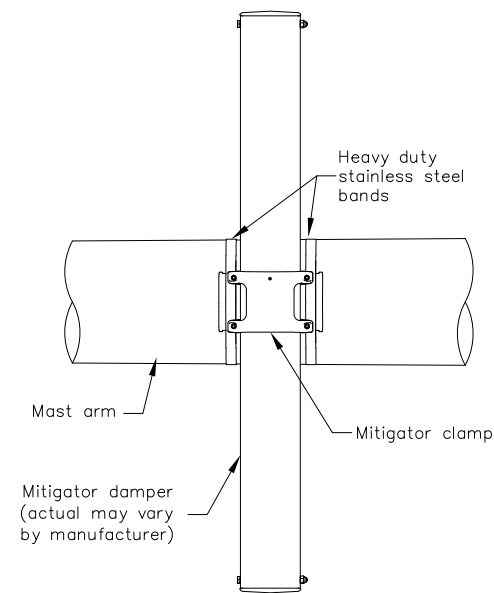

2 VIBRATION MITIGATOR CONNECTION DETAIL

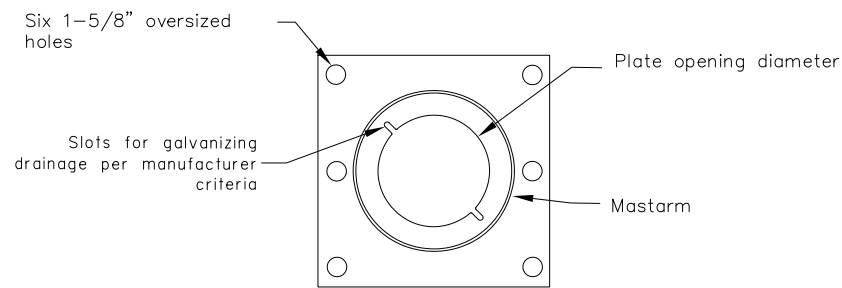

MASTARM BASE PLATE

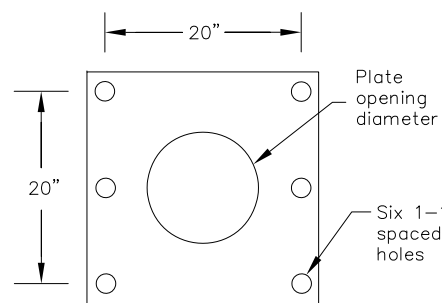

MASTARM MOUNTING PLATE

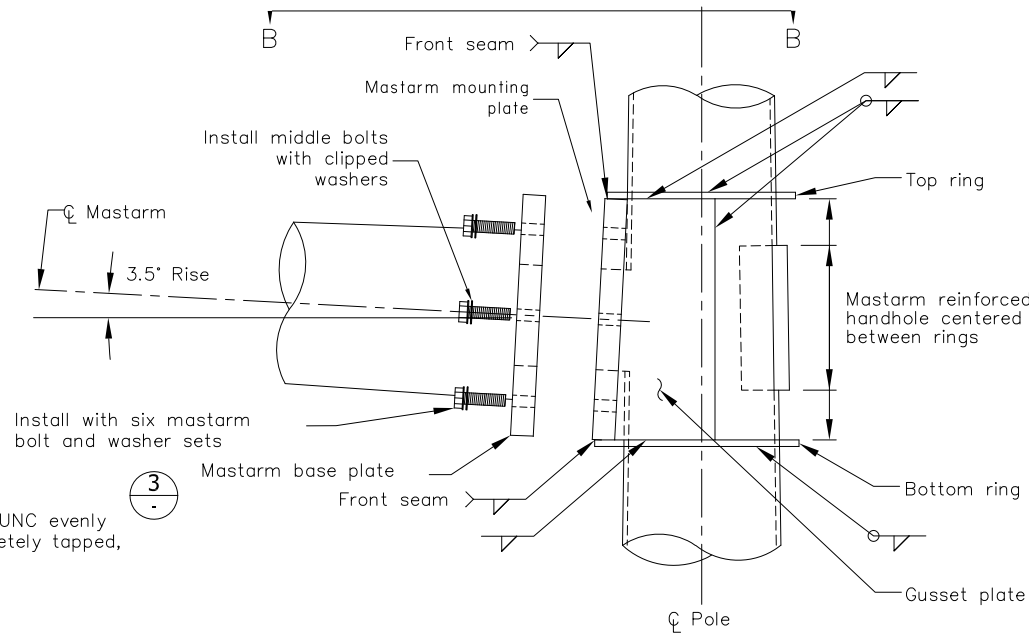

SIDE VIEW

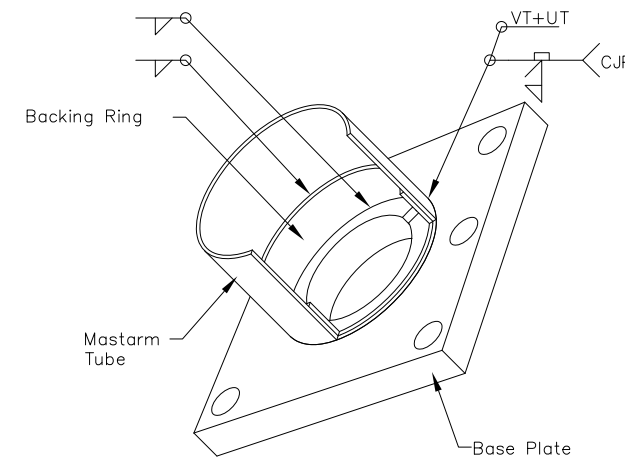

ISO VIEW

TUBE TO TRANSVERSE PLATE WELD DETAIL

3 (Shown with tube and backing ring cutout for clarity)

1 RING - STIFFENED BOX DETAILS
NTS

MATERIAL REQUIREMENTS	
MATERIAL QUALITY GUIDANCE	
Steel ≤ 1/2" Thick	ASTM A572 OR A595
Steel > 1/2" Thick	ASTM A709 (50ksi - Zone 3)
Finish	ASTM A123 & A153
Mastarm Bolts	ASTM F3125
Mastarm Washers	ASTM F436
Anchor Rods	See T-52
RING-STIFFENED BOX	
Mastarm Mounting Plate	24" x 24" x 2.25"
Plate Opening Diameter	Mastarm Data (See Sheet 1)
Top Ring Thickness	0.375"
Bottom Ring Thickness	0.375"
Gusset Plate Thickness	0.375"
MASTARM HANDHOLE	
Outside Dimensions	7" x 12.89"
Reinforcing Material	0.5" x 3"
Handhold Cover	0.125"
MASTARM	
Design Length	65'
Section Shape	Round
Plate Opening Diameter	Mastarm Data (See Sheet 1)
Mastarm Tube Thickness	Mastarm Data (See Sheet 1)
Fixed End Diameter	Mastarm Data (See Sheet 1)
Mastarm Rise	3.5 Degrees
Mastarm Baseplate	24" x 24" x 2.25"
Backing Ring	0.25" x 3"
Mastarm Bolts	1.5" 6 UNC x 5.5"

State of Alaska DOT&PF
ALASKA STANDARD PLAN
**SIGNAL POLE
WITH 55' TO 65' MASTARM
MASTARM & STIFFENED BOX**

Adopted as an Alaska Standard Plan by: *Carolyn H Morehouse*
Carolyn Morehouse, P.E.
Chief Engineer

Adoption Date: 9/15/2022

Last Code and Slds. Review
By: Date: 5/13/2021

Next Code and Standards Review date: 5/13/2031

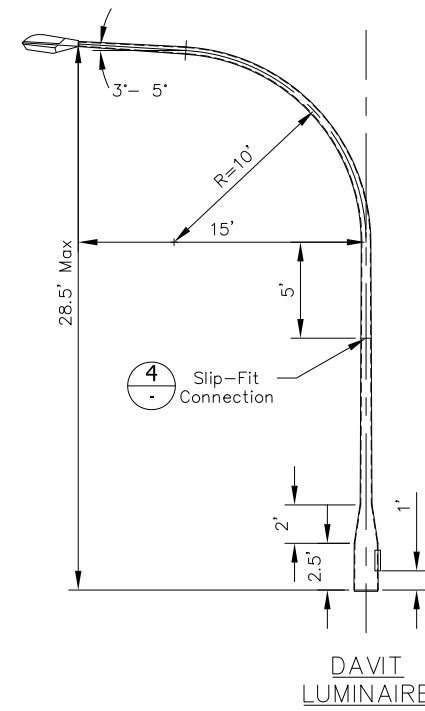
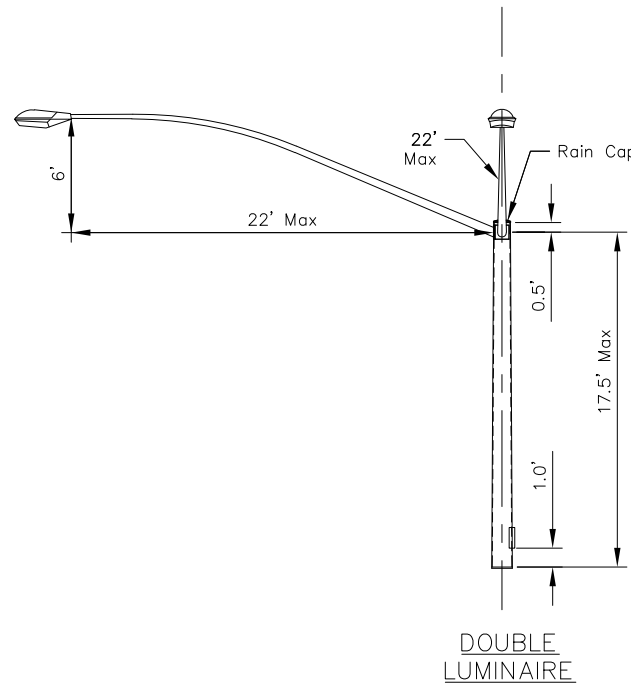
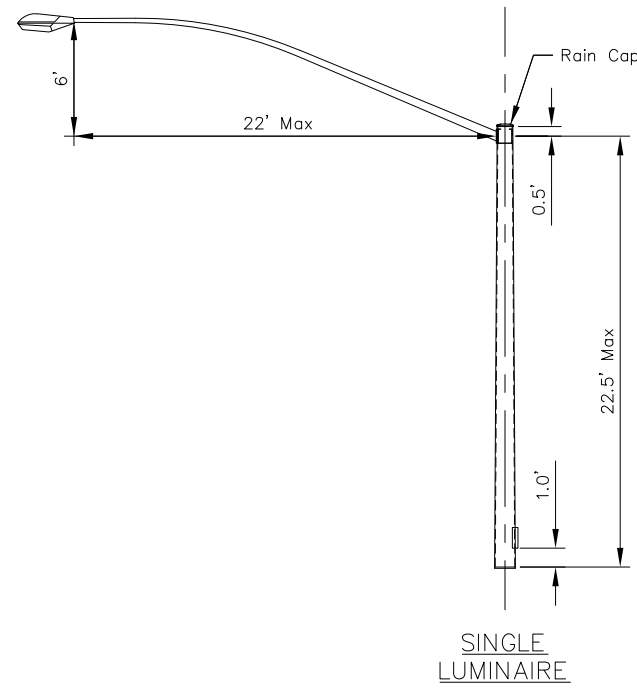

UPPER SECTION OPTIONS
NTS

MATERIAL REQUIREMENTS	
MATERIAL QUALITY GUIDANCE	
Tube Material	A572, A595 GR A, or A1011 (50ksi min)
Post Top Connecting Plates	ASTM A709 (Zone 3)
Concentric Reducer	A572 OR A595 GR A
Connection Tube	A572 OR A595 GR A
Luminaire, Arm, and Mounting	See Lighting Standard Details
Upper Section Connection Bolts	ASTM F3125
Upper Section Connection Bolts	ASTM F436
Slip Fit Through Bolt	ASTM F3125
Finish	ASTM A123 & A153
STANDARD UPPER SECTION	
Fixed End Diameter	15.99" O.D.
Taper	0.14"/ft
Connecting Plate Thickness	1"
Post Top Connection Bolts	1" 8 UNC x 2.75"
Tube Thickness	7 GA
HANDHOLE DIMENSIONS	
Upper Section Handhole	7" x 12.89"
Reinforcing Material	0.5" x 3"
Handhole Cover	0.125"
SINGLE LUMINAIRE	
Design Length	22.5'
Section Shape	Round
DOUBLE LUMINAIRE	
Design Length	17.5'
Section Shape	Round
DAVIT LUMINAIRE	
Design Length	28.5'
Section Shape	Round
Taper	0.14'/ft
Free End Diameter	2.375" O.D.
Connection Tube	7 GA
Concentric Reducer	7 GA
Davit Arm Connection Tube	7 GA
Davit Arm	7 GA

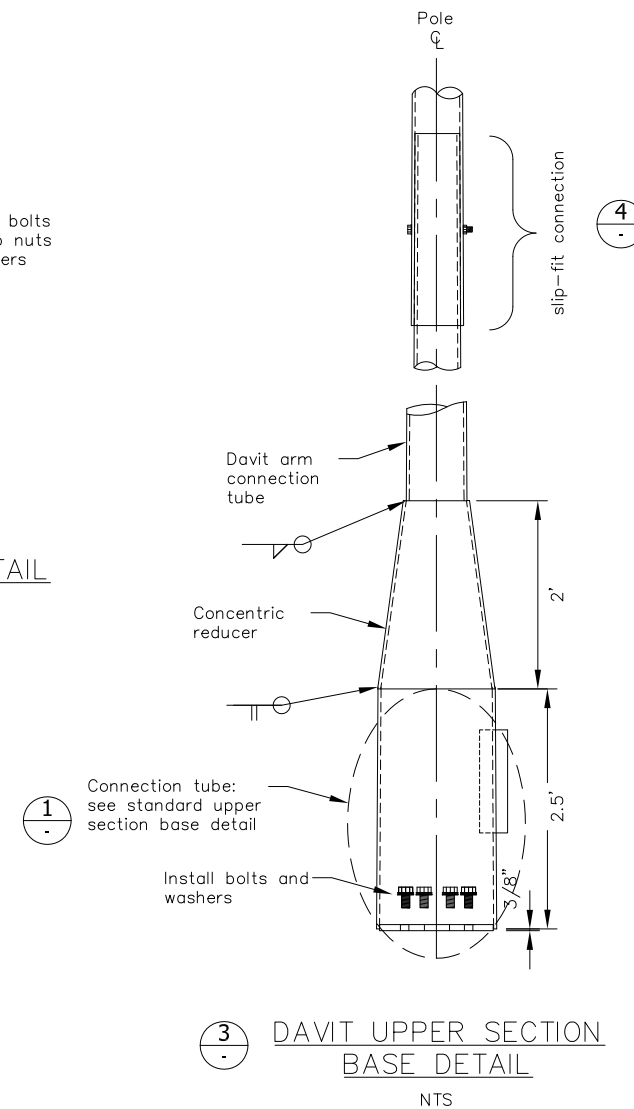
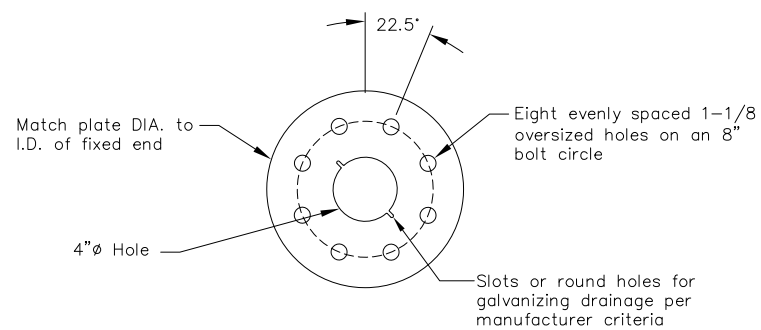
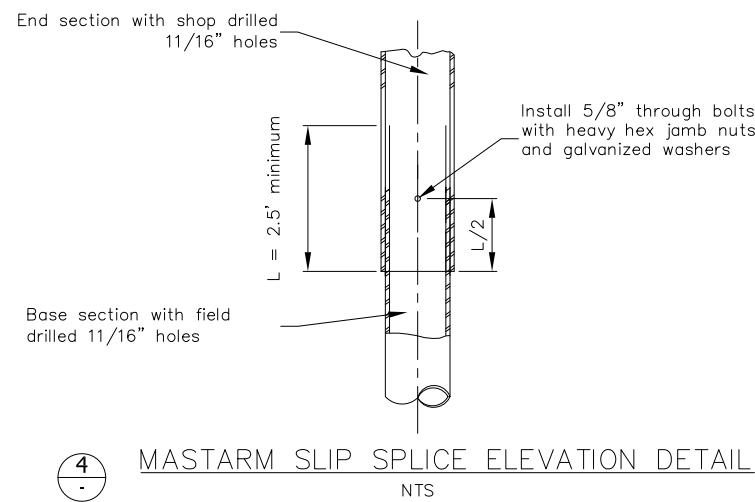
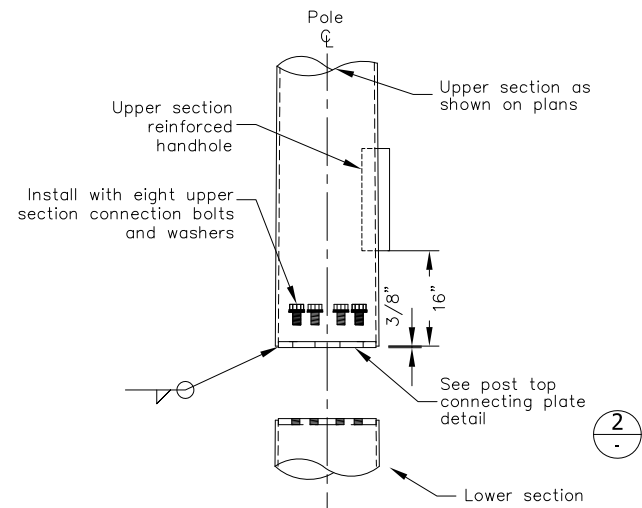

State of Alaska DOT&PF
ALASKA STANDARD PLAN

**SIGNAL POLE
WITH 55' TO 65' MASTARM
UPPER SECTION**

Adopted as an Alaska Standard Plan by: *Carolyn H Morehouse*
Carolyn Morehouse, P.E.
Chief Engineer

Adoption Date: 9/15/2022

Last Code and Stds. Review
By: Date: 5/13/2021

Next Code and Standards Review date: 5/13/2031

POLE DESIGN LOADING						
Load Component	Height (ft.)	Weight (lbs.)	Ice Area (sq. ft.)	Wind Area (Face) (sq. ft.)	Wind Area (Side) (sq. ft.)	Fatigue Area (Bottom) (sq. ft.)
1 = Luminaire	0.5	25	8.1	0.6	1.0	2.5
2 = Signal	4.5	54	2.9	8.7	4.8	1.4
3 = Signal	5.6	70	37.5	11.0	6.4	1.4
4 = Ped Head	1.4	22	7.8	2.2	0.8	0.9
5 = Sign	2.5	120	69.7	30.0	0.8	4.0

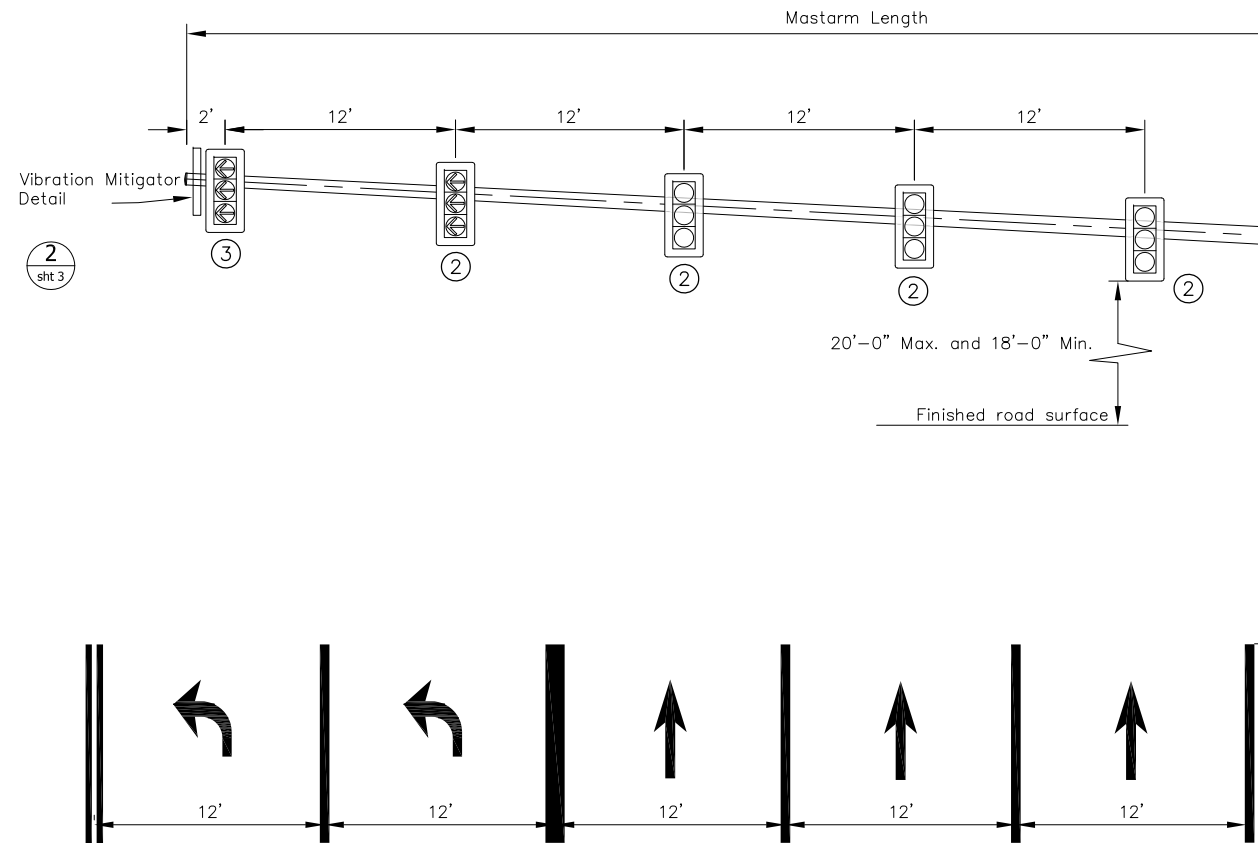
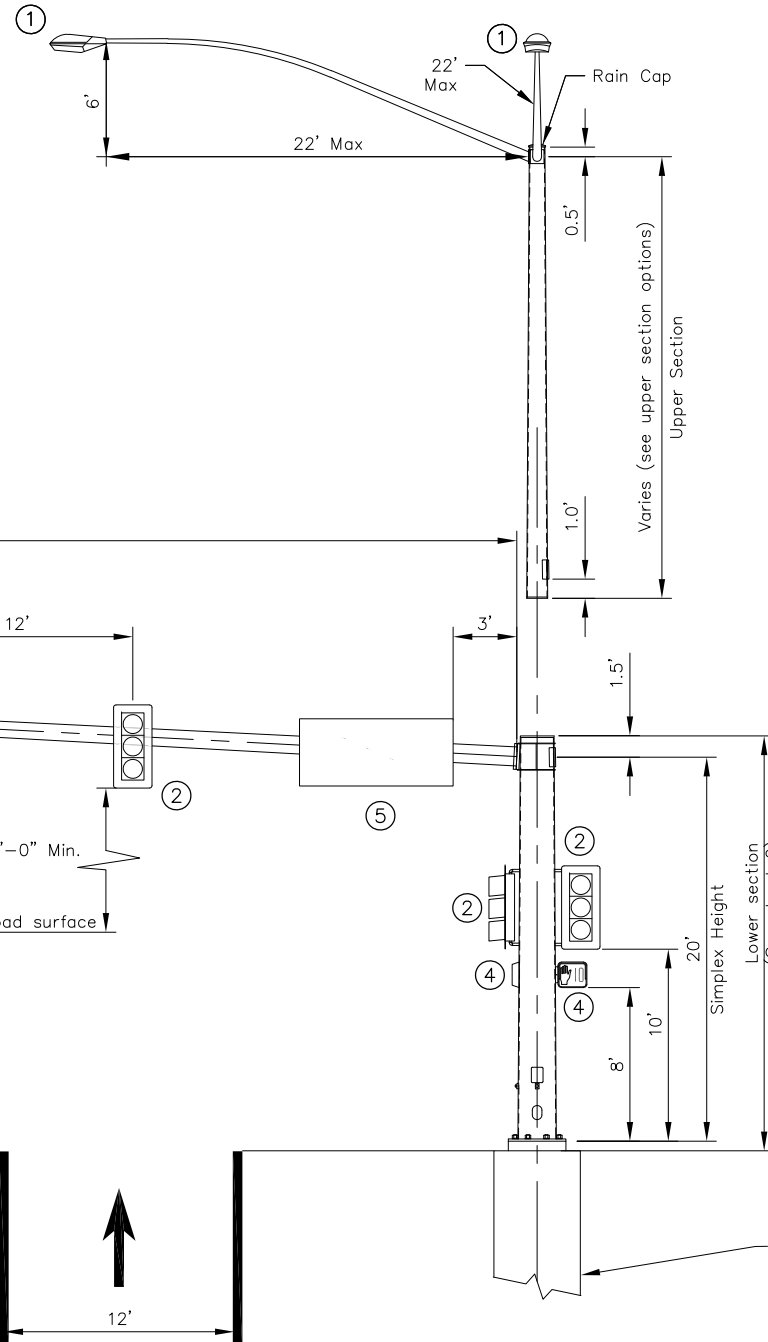

NOTES:

- Provide pole assemblies designed, manufactured and installed according to: 2013 AASHTO Standard Specifications for Structural Supports for Highway Signs, Luminaires and Traffic Signals with 2013 Errata and 2015 Interim Revision, the latest edition of the Alaska Standard Specifications for Highway Construction including standard modifications, and special provisions. Design structures for a 50-year Design Life, Fatigue Category I with ice loading, and with a basic wind speed of 100 mph. Fatigue design shall include Natural Wind Gust, Truck-Induced Gust, and an approved vibration mitigating device in lieu of Galloping effect.
- Provide poles to accommodate the maximum length shown in the mastarm data with the given loads, dimensions, and material requirements.
- This drawing shows loads (signs and signals) to be used by manufacturers when designing poles. It does not show actual loading of poles/mastarms on individual projects. This pole/mastarm design may be used without further analysis if the following conditions are met:
 - The guide sign (load #5) is attached to the mastarm base section and,
 - Not more than 5 traffic signals and/or signs are attached to the mastarm.
 If these conditions are not met, this standard pole/mastarm design may only be used if design computations are submitted that demonstrate conformance to design criteria (note 1) using actual loads. Devices with less than 1 square foot of projected area may be added to the mastarm without causing a need for additional design computations.
- The manufacturer is to determine weld sizes. All welds and testing shall conform to the latest edition of the structural welding code AWS D1.1. Provide visual testing (VT) of 100% of all welds. Provide magnetic particle testing (MT) of 100% of all fillet welds. Provide radiographic (RT) or ultrasonic testing (UT) of 100% of all complete joint penetration welds and a random 25% of all partial joint penetration longitudinal seam welds.
- Fabricate pole tubes and mastarm tubes from no more than 2 pieces of steel. When using 2 pieces, place the longitudinal welded seams directly opposite one another. Transverse weld seams prohibited.
- Fabricate luminaire arms and connections according to the latest lighting standard detail.
- Provide permanent tags on all pole sections per section 740 table 740-1 of the specifications. Provide a weather proof rain cap on all exposed sections of the structure.
- The Department will reject damaged or defective poles for any of the following; variances from approved shop drawings, variances from material requirements, sections more than 2-percent out of round, flanged mounting surfaces with flatness variation greater than 0.030", sections bowed more than 1-inch throughout the length of the pole, mastarm, or segment, and damaged or dented finishes.
- To allow for wiring, field drill a 1" maximum diameter hole at each traffic signal head location. Orient the hole on the horizontal axis of mastarms.
- Install pole raked outward from plumb position in the direction opposite the mastarm such that the side of the pole opposite the mastarm is vertical.
- Clean and remove dirt, burrs, mill scale, and excess galvanization on all faying surfaces and threaded parts before assembly. Lubricate the threads of all bolts and nuts with lubricant containing a visible dye. Tighten all bolts according to section 504 of the specifications.

MASTARM DATA									
MASTARM		MASTARM END SECTION			MASTARM BASE SECTION			MASTARM BASEPLATE	
Length (ft.)	Maximum Allowed Galloping Deflection (in.)	Free End Diameter (in.)	Length (ft.)	Tube Thickness (in.)	Length (ft.)	Fixed End Diameter*	Tube Thickness (in.)	Plate Opening Diameter (in.)	Plate Thickness (in.)
70	12.0	7.5	40.0	0.1793	32.9	16.7	0.375	11.0	2.25
75	12.0	7.5	40.0	0.1793	37.9	17.4	0.375	11.0	2.25

*Fixed end diameter measured at connection to Baseplate

State of Alaska DOT&PF
ALASKA STANDARD PLAN

**SIGNAL POLE
WITH 70' TO 75' MASTARM
LOADING & NOTES**

Adopted as an Alaska Standard Plan by: *Carolyn H. Morehouse*
Carolyn Morehouse, P.E.
Chief Engineer

Adoption Date: 9/15/2022

Last Code and Stds. Review
By: Date: 5/13/2021

Next Code and Standards Review date: 5/13/2031

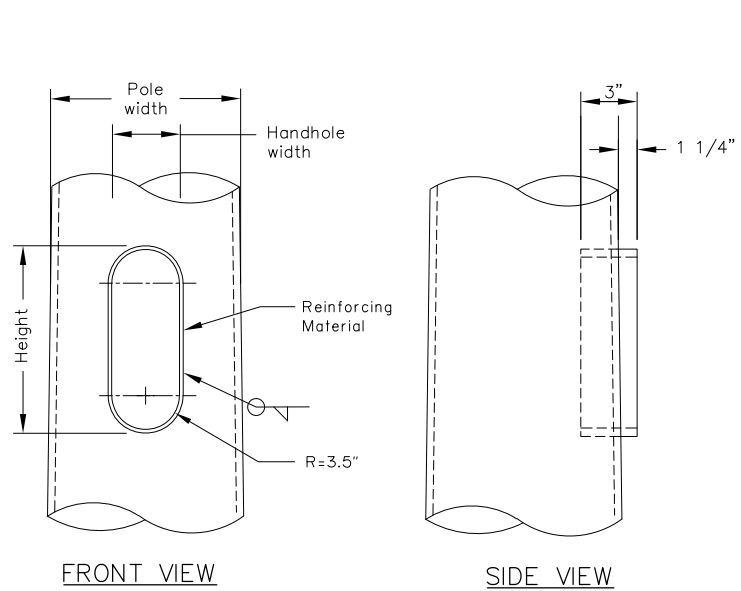

FRONT VIEW
SIDE VIEW
REINFORCED HANDHOLE

1
-
-
(See material requirements table for dimensions)

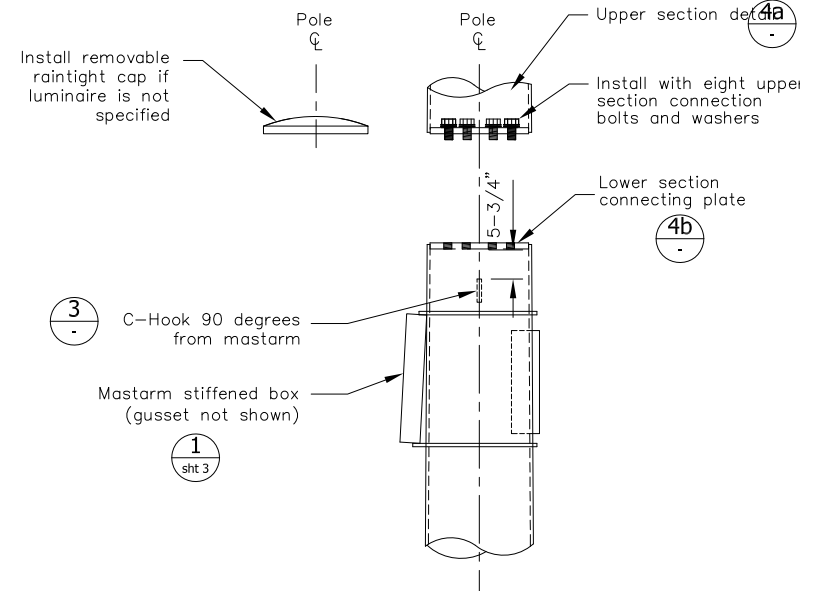

4
-
-
LOWER SECTION POST TOP DETAIL

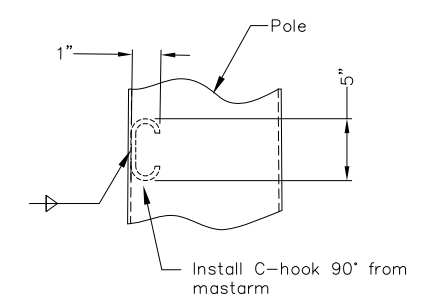

3
-
-
C-HOOK DETAIL
(Typical throughout lower section)
NTS

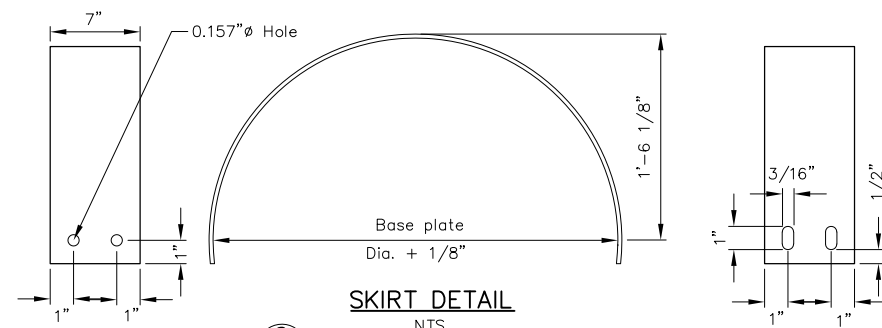

2
-
-
SKIRT DETAIL
NTS
(Two required per pole)

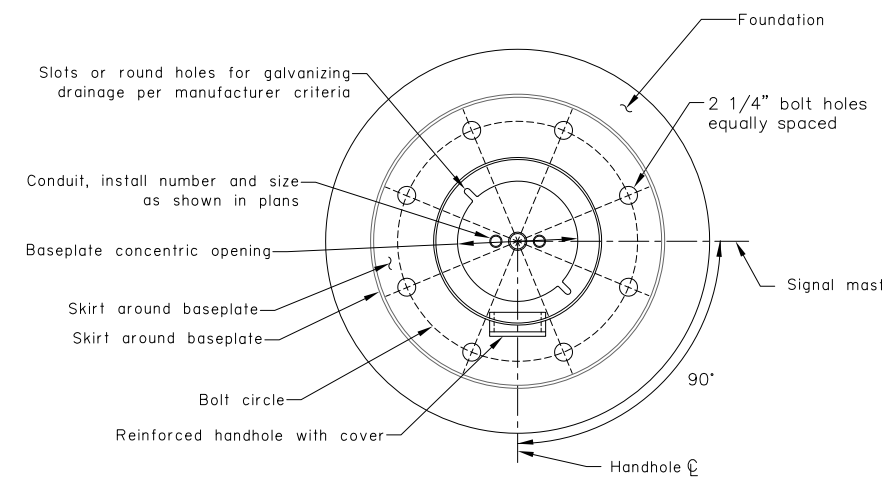

PLAN VIEW
(Shown without anchor bolts and nuts for clarity)

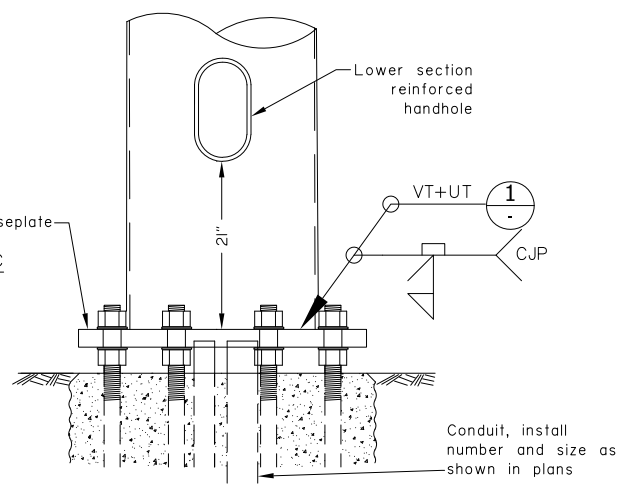

FRONT VIEW
(Skirt omitted for clarity)

5
-
-
POLE BASE DETAIL
NTS

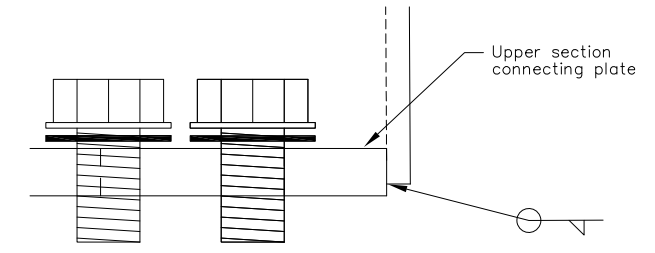

4a
-
-
POST TOP UPPER SECTION CONNECTING PLATE

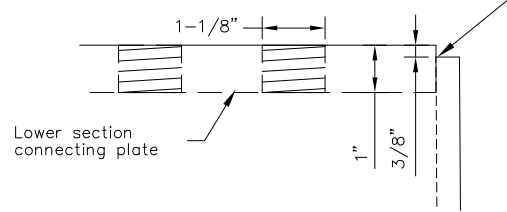

4b
-
-
POST TOP LOWER SECTION CONNECTING PLATE

MATERIAL REQUIREMENTS	
MATERIAL QUALITY GUIDANCE	
Steel ≤ 1/2" Thick	ASTM A572 OR A595
Steel > 1/2" Thick	ASTM A709 (50ksi - Zone 3)
Finish	ASTM A123 & 153
Mastarm Bolts	ASTM F3125
Mastarm Washers	ASTM F436
Anchor Rods	See T-53
POLE (LOWER SECTION)	
Design Length	21.50'
Section Shape	Round
Simplex Height	20.0'
Taper	0.14'/ft
Baseplate Bolt Circle Diameter	30.0"
Diameter Concentric Opening	15.0"
Tube Thickness	0.375"
Fixed End Diameter	21.0" OD
Base Plate	36" O.D. x 2.25"
Backing Ring	0.25" x 3"
HANDHOLE DIMENSIONS	
Outside Dimensions	7" x 12.89"
Reinforcing Material	0.5" x 3"
Handhole Cover	0.125"
MISCELLANEOUS	
Post Top Connecting Plates	1.00"
Pole Skirt	0.125"
C-Hook	0.50"

State of Alaska DOT&PF
ALASKA STANDARD PLAN

SIGNAL POLE WITH 70' TO 75' MASTARM LOWER SECTION

Adopted as an Alaska Standard Plan by: Carolyn Morehouse, P.E.
Chief Engineer

Adoption Date: 9/15/2022

Last Code and Sds. Review By: _____ Date: 5/13/2021

Next Code and Standards Review date: 5/13/2031

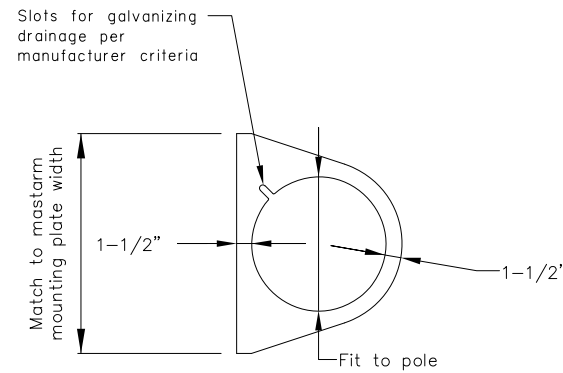

RING DETAIL

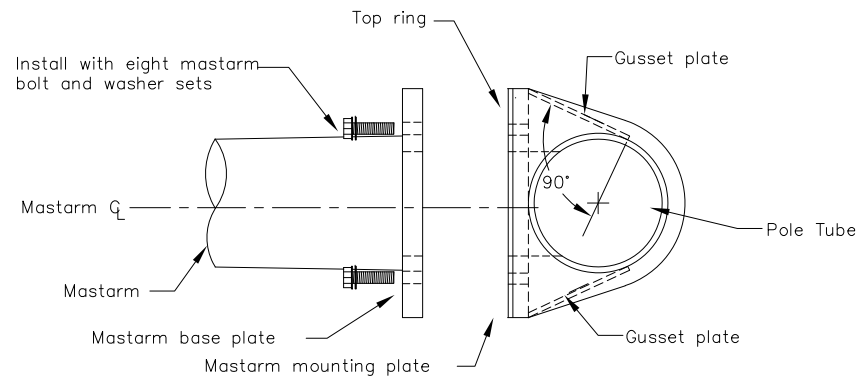

SECTION B-B

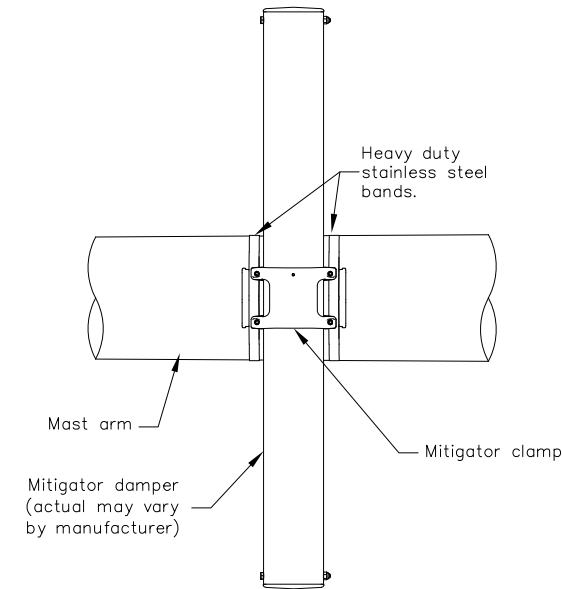

2 VIBRATION MITIGATOR CONNECTION DETAIL

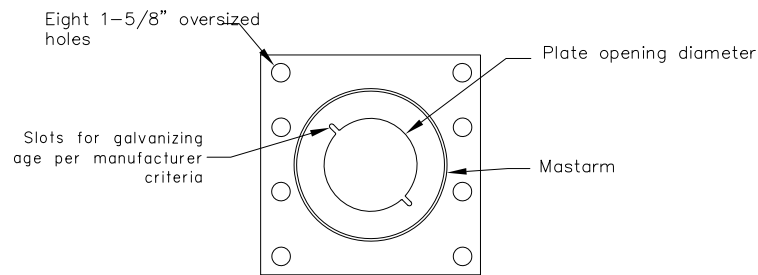

MASTARM BASE PLATE

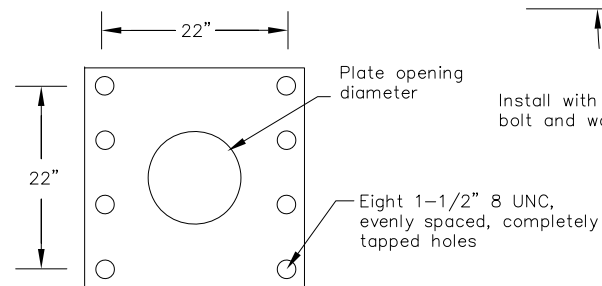

MASTARM MOUNTING PLATE

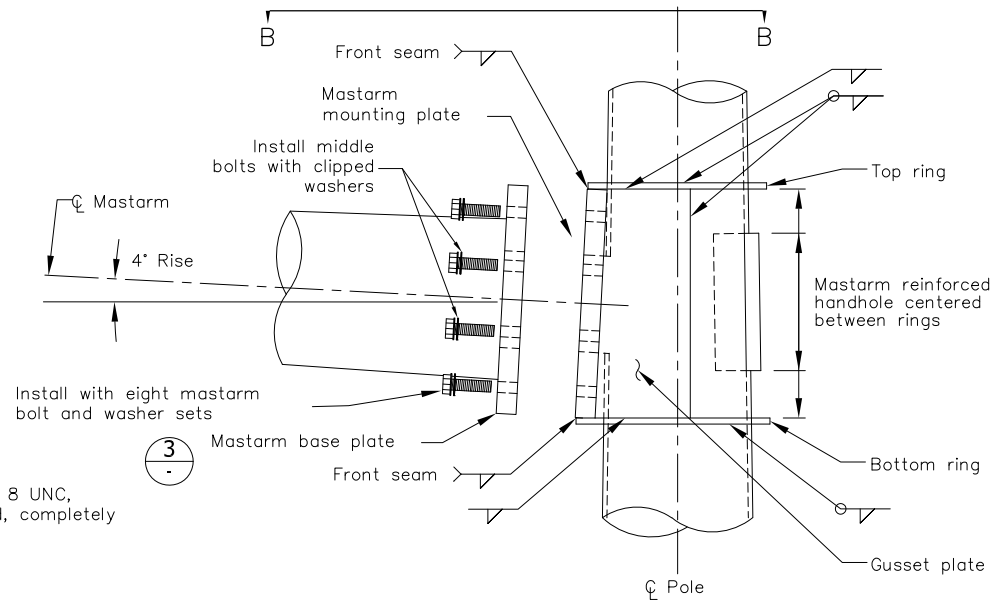

SIDE VIEW

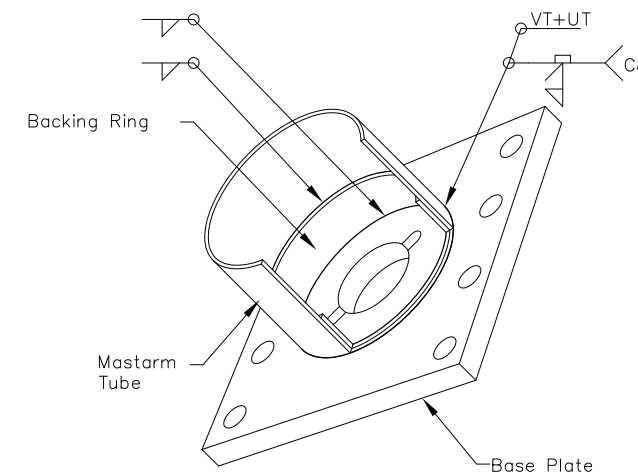

ISO VIEW

TUBE TO TRANSVERSE PLATE WELD DETAIL

(Shown with tube and backing ring cutout for clarity)

1 RING - STIFFENED BOX DETAILS
NTS

3

MATERIAL REQUIREMENTS	
MATERIAL QUALITY GUIDANCE	
Steel ≤ 1/2" Thick	ASTM A572 OR A595
Steel > 1/2" Thick	ASTM A709 (50ksi - Zone 3)
Finish	ASTM A123 & A153
Mastarm Bolts	ASTM F3125
Mastarm Washers	ASTM F436
Anchor Rods	See T-53
RING-STIFFENED BOX	
Mastarm Mounting Plate	26" x 26" x 2.25"
Plate Opening Diameter	Mastarm Data (See Sheet 1)
Top Ring Thickness	0.375"
Bottom Ring Thickness	0.375"
Gusset Plate Thickness	0.375"
MASTARM HANDHOLE	
Outside Dimensions	7" x 12.89"
Reinforcing Material	0.5" x 3"
Handhold Cover	0.125"
MASTARM	
Design Length	75'
Section Shape	Round
Plate Opening Diameter	Mastarm Data (See Sheet 1)
Mastarm Tube Thickness	Mastarm Data (See Sheet 1)
Fixed End Diameter	Mastarm Data (See Sheet 1)
Mastarm Rise	4.0 degrees
Mastarm Baseplate	26" x 26" x 2.25"
Backing Ring	0.25" x 3"
Mastarm Bolts	1.5" 6 UNC x 5.5"

State of Alaska DOT&PF
ALASKA STANDARD PLAN

SIGNAL POLE WITH 70' TO 75' MASTARM MASTARM & STIFFENED BOX

Adopted as an Alaska Standard Plan by: *Carolyn H. Morehouse*
Carolyn Morehouse, P.E.
Chief Engineer

Adoption Date: 9/15/2022

Last Code and Sds. Review By: Date: 5/13/2021
Next Code and Standards Review date: 5/13/2031

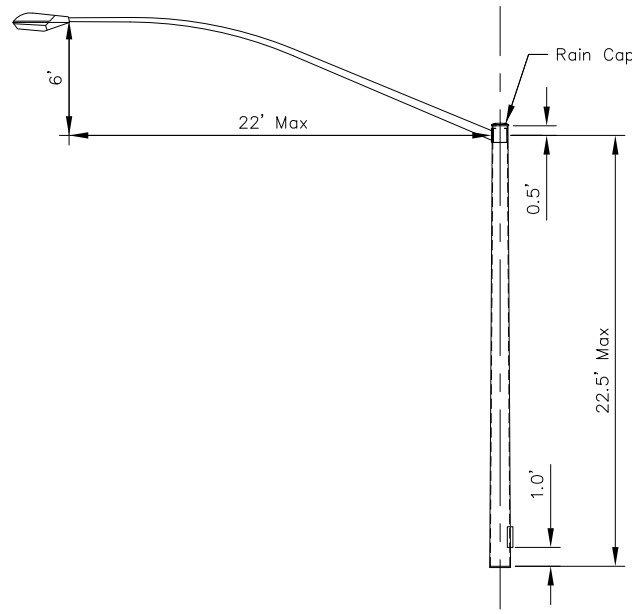

SINGLE LUMINAIRE

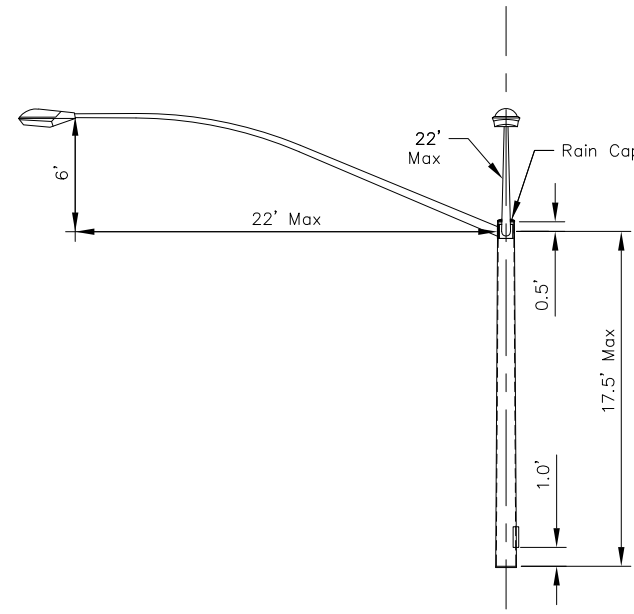

DOUBLE LUMINAIRE

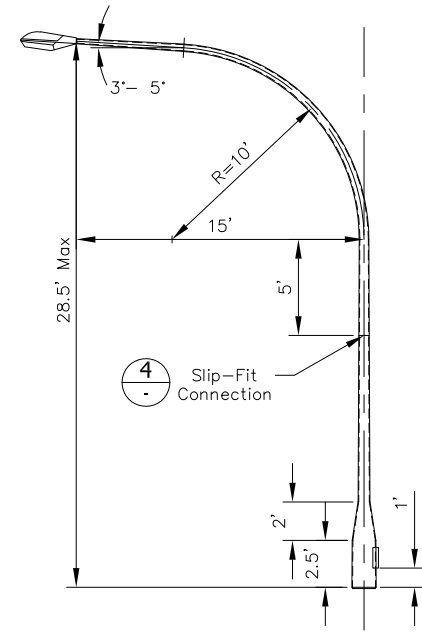

DAVIT LUMINAIRE

UPPER SECTION OPTIONS
NTS

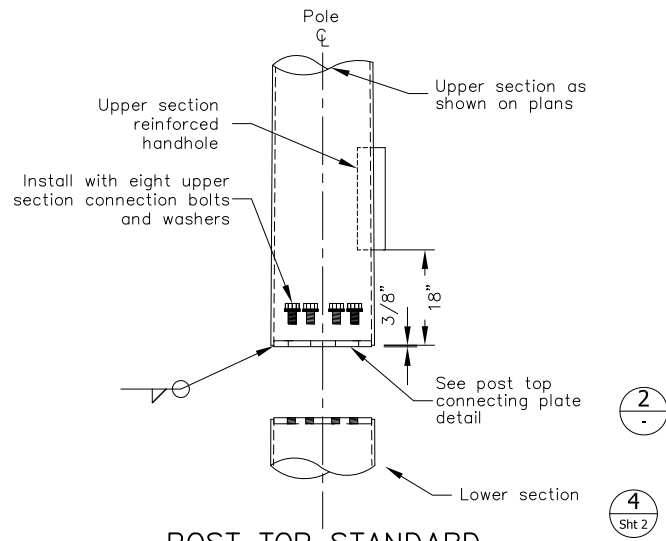

POST TOP STANDARD UPPER SECTION BASE DETAIL

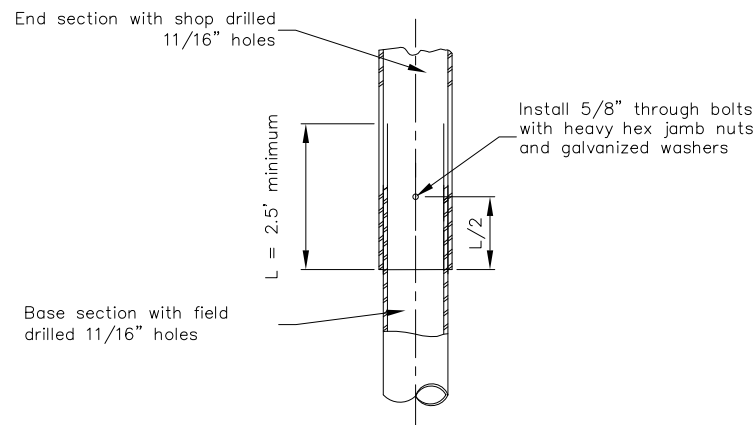

MASTARM SLIP SPLICE ELEVATION DETAIL
NTS

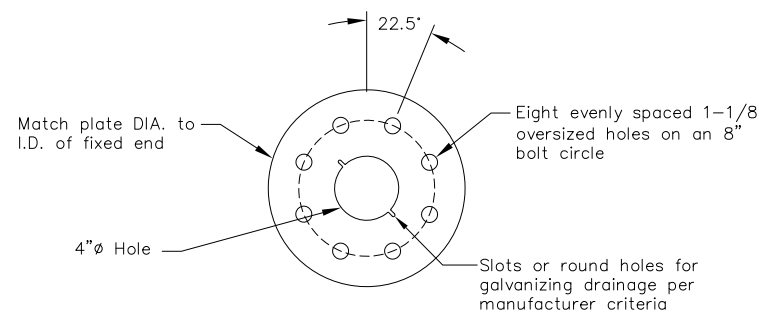

POST TOP CONNECTING PLATE DETAIL

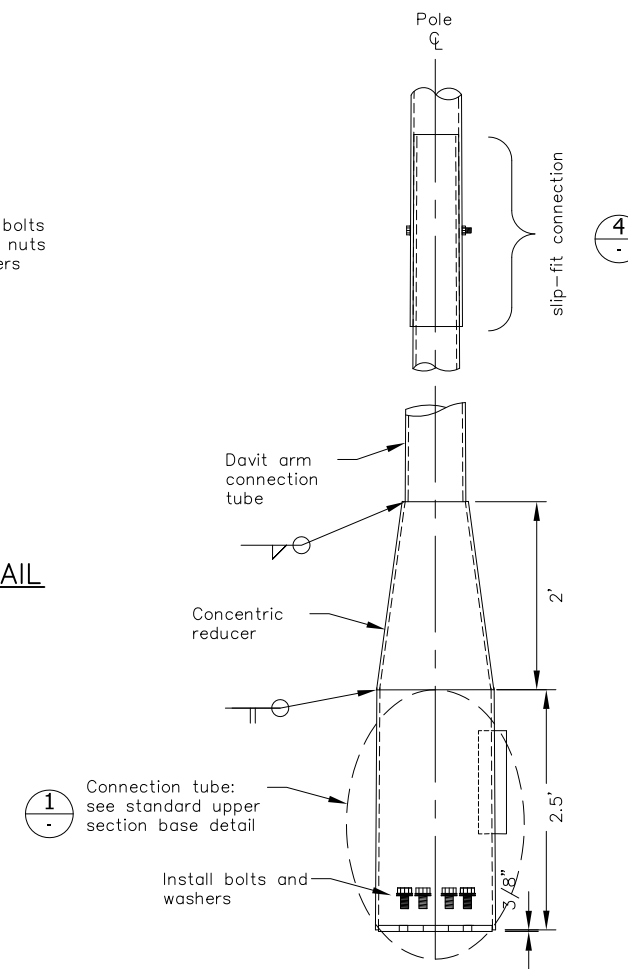

DAVIT UPPER SECTION BASE DETAIL
NTS

MATERIAL REQUIREMENTS	
MATERIAL QUALITY GUIDANCE	
Tube Material	A572, A595 GR A, or A1011 (50ksi min)
Post Top Connecting Plates	ASTM A709 (Zone 3)
Concentric Reducer	A572 OR A595 GR A
Connection Tube	A572 OR A595 GR A
Luminaire, Arm, and Mounting	See Lighting Standard Details
Upper Section Connection Bolts	ASTM F3125
Upper Section Connection Bolts	ASTM F436
Slip Fit Through Bolt	ASTM F3125
Finish	ASTM A123 & A153
STANDARD UPPER SECTION	
Fixed End Diameter	17.99" O.D.
Taper	0.14"/ft
Connecting Plate Thickness	1"
Post Top Connection Bolts	1" 8 UNC x 2.75"
Tube Thickness	7 GA
HANDHOLE DIMENSIONS	
Upper Section Handhole	7" x 12.89"
Reinforcing Material	0.5" x 3"
Handhole Cover	0.125"
SINGLE LUMINAIRE	
Design Length	22.5'
Section Shape	Round
DOUBLE LUMINAIRE	
Design Length	17.5'
Section Shape	Round
DAVIT LUMINAIRE	
Design Length	28.5'
Section Shape	Round
Taper	0.14'/ft
Free End Diameter	2.375" O.D.
Connection Tube	7 GA
Concentric Reducer	7 GA
Davit Arm Connection Tube	7 GA
Davit Arm	7 GA

State of Alaska DOT&PF
ALASKA STANDARD PLAN

SIGNAL POLE WITH 70' TO 75' MASTARM UPPER SECTION

Adopted as an Alaska Standard Plan by: *Carolyn H. Morehouse*
Carolyn Morehouse, P.E.
Chief Engineer

Adoption Date: 9/15/2022

Last Code and Stds. Review
By: Date: 5/13/2021

Next Code and Standards Review date: 5/13/2031

THRUST BLOCK MINIMUM SIZE TABLE
For Bends Greater Than 45°, Tee Branches & Crosses

Pipe Diam. (In.)	Water Pressure in Pipe (P.S.I.)					
	50		150		250	
	Bearing Area (Sq. Ft.)	Concrete Volume (Cu. Ft.)	Bearing Area (Sq. Ft.)	Concrete Volume (Cu. Ft.)	Bearing Area (Sq. Ft.)	Concrete Volume (Cu. Ft.)
2	0.5	0.5	0.8	1.0	1.0	1.3
3	0.6	0.8	1.0	1.3	1.1	1.5
4	0.8	1.0	1.6	3.1	1.5	3.0
6	1.0	1.3	1.9	4.0	3.2	7.0
8	1.1	1.5	3.2	7.0	5.4	11.0
10	1.7	3.2	4.9	10.0	8.3	19.0
12	2.4	5.2	7.1	17.0	11.8	24.3
14	3.2	7.0	9.8	21.0	16.1	32.0
16	4.1	8.0	12.3	25.0	20.5	40.0
18	5.4	11.0	16.2	32.0	27.1	50.0
20	6.8	15.0	20.6	40.0	34.4	70.0
24	8.2	19.0	25.3	50.0	42.0	80.0

For Bends 45° or Less

2	0.5	0.5	0.5	0.5	0.6	0.8
3	0.5	0.5	0.7	0.9	0.8	1.0
4	0.5	0.5	0.9	1.1	1.0	1.5
6	0.6	0.8	1.2	2.0	1.7	3.2
8	0.8	1.0	1.8	3.6	2.9	6.0
10	1.0	1.3	2.7	5.8	4.5	9.0
12	1.3	2.5	3.8	7.5	6.4	14.0
14	1.7	3.2	5.2	11.0	8.6	19.0
16	2.2	4.5	6.7	15.0	11.2	24.0
18	2.8	5.9	8.5	19.0	14.1	30.0
20	3.5	7.0	10.5	22.2	17.5	35.0
24	4.2	8.0	12.8	26.0	21.5	40.0

VALVES REQUIRING ANCHORAGE

WORKING PRESSURE (P.S.I.)	VALVES REQUIRING ANCHORAGE
50 - 100	12 Inch and up
101 - 150	8 Inch and up
151 - 200	All Sizes

THRUST AT VERTICAL BEND PER DEGREE DEFLECTION AT 100 P.S.I. WATER PRESSURE

PIPE SIZE	THRUST (LB.)	PIPE SIZE	THRUST (LB.)
4"	35	10"	197
6"	72	12"	278
8"	122	14"	377
		16"	486

GENERAL NOTES:

1. Thrust blocks are to be concrete poured in place between the fitting and undisturbed trench wall.
2. Concrete shall be kept centered behind bell of fitting and not obstructing pipe joints.
3. Thrust blocks are required whenever pipe-line changes direction, changes size, dead ends, or develops thrust at valves.
4. Material, behind the thrust blocks, deemed unsuitable by the engineer shall be removed and replaced as directed by the engineer.
5. In impervious soils, a hole shall be dug beneath the hydrant thrust block to a minimum volume of 7 cubic feet. The hole shall be filled with porous backfill material.
6. Refer to AWWA C600-64 Section II for placement of hydrant
7. Orient hydrant with nozzles facing street.

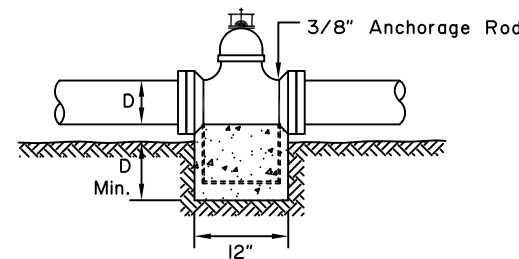

ANCHORAGE OF VALVES

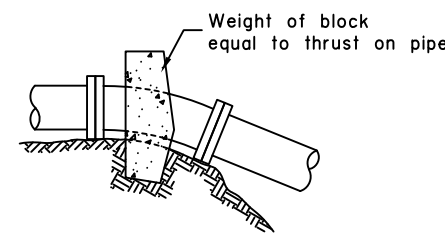

VERTICAL BENDS

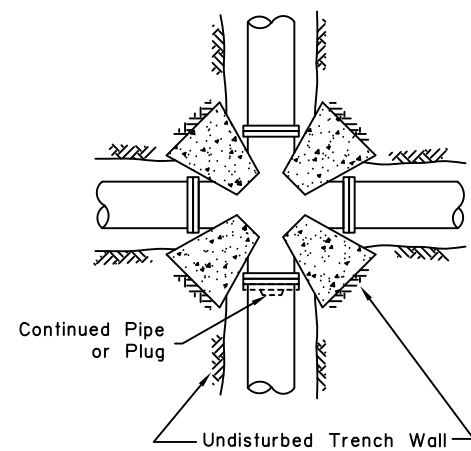
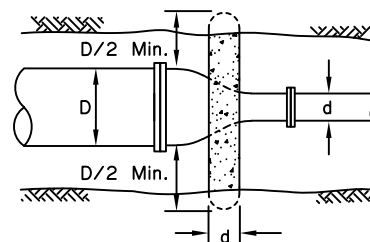
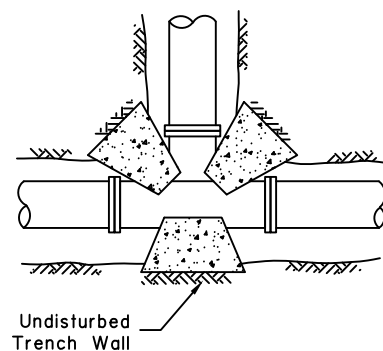
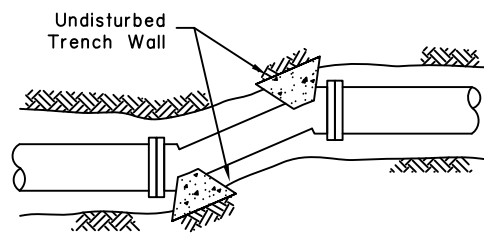
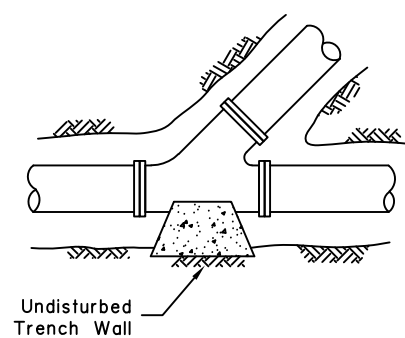
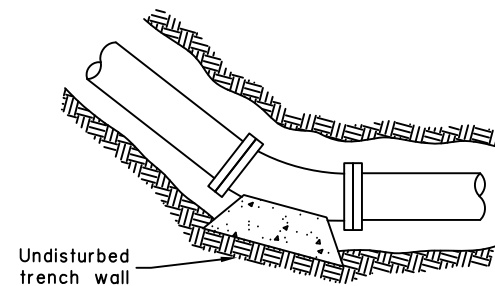

PLACEMENT OF THRUST BLOCKS

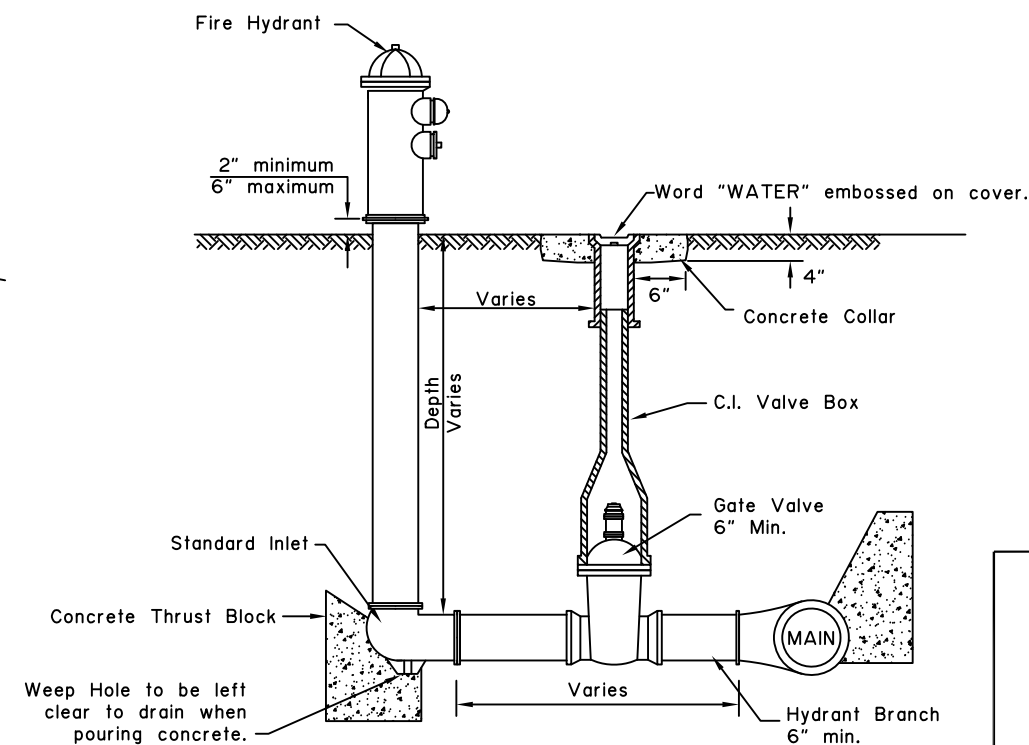

No bends shall exceed 11 1/4" between the hydrant and the main.

STANDARD HYDRANT

State of Alaska DOT&PF
ALASKA STANDARD PLAN

THRUST BLOCKS

Adopted as an Alaska Standard Plan by: *Kenneth J. Fisher*
Kenneth J. Fisher, P.E.
Chief Engineer

Adoption Date: 02/08/2019

Last Code and Stds. Review By: Date:

Next Code and Standards Review date: 02/08/2029