

Mid-Block

**SIDEWALK, PATHWAY, OR SHOULDER CLOSURE:  
DIVERSION AWAY FROM ROADWAY  
TYPICAL APPLICATION DETAILS**

(If RIGHT-OF-WAY space available)

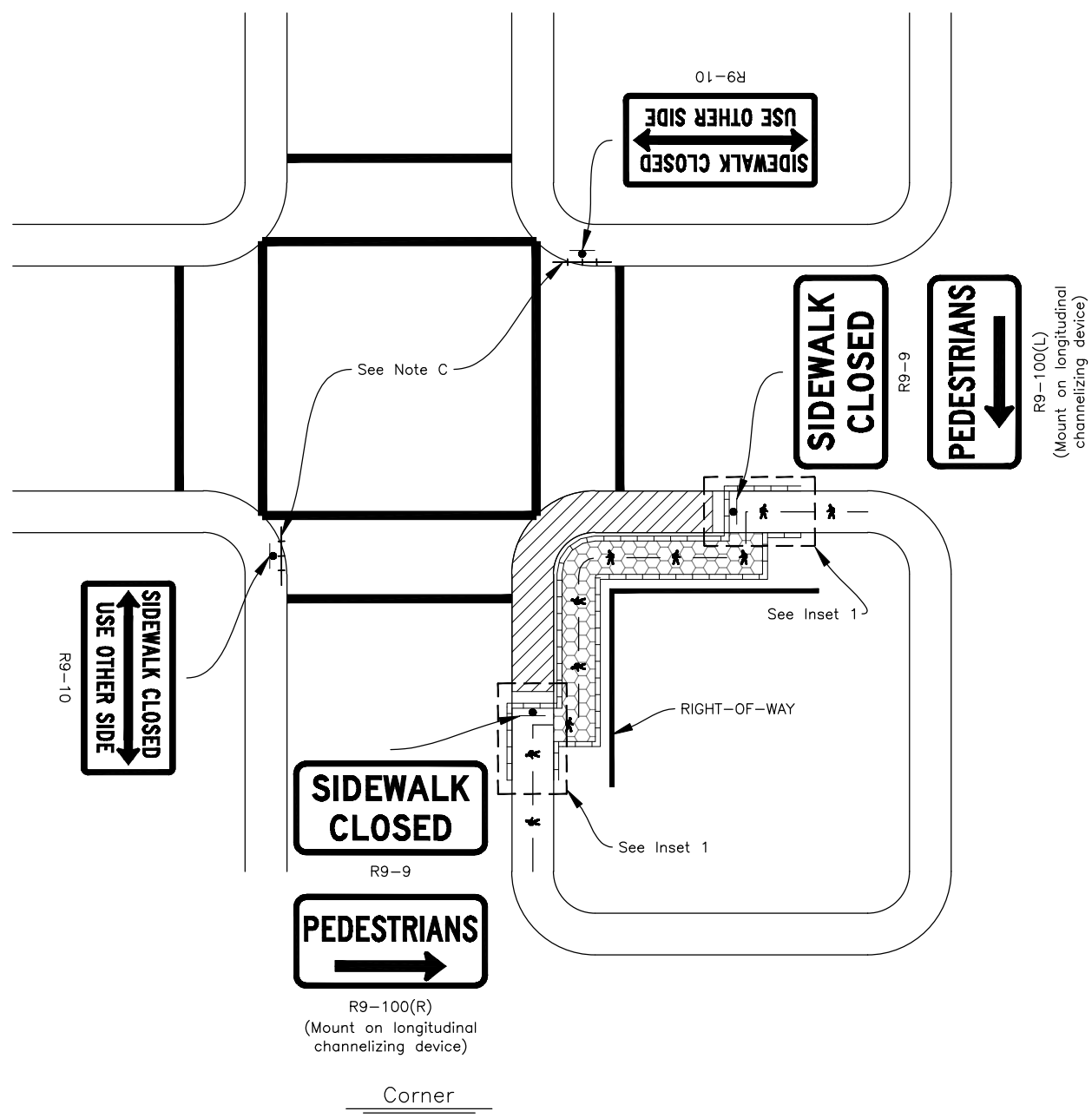

**LEGEND:**

	ADA Compliant Longitudinal Channelizing Device
	Temporary Pedestrian Accessible Route Diversion
	Temporary Pedestrian Accessible Route
	Work Zone
	Sign
	Type III Barricade

**GENERAL NOTES FOR TYPICAL APPLICATION DETAILS:**

1. Only traffic control devices (TCD) for pedestrians are shown. Other TCD may be necessary to control vehicular traffic.
2. Provide longitudinal channelizing devices when sidewalks or pathways are closed to pedestrians and where required by the Plans or Specifications. When pre-construction project conditions are disrupted, closed, or relocated in a temporary traffic control zone, the temporary pedestrian accessible route (TPAR) shall be detectable and include accessibility features consistent with the features present in the existing pedestrian facility.
3. Typical applications details depicted on Sheets 1 through 3 are in order of preference. Avoid unnecessary pedestrian routing detours. Use Sheet 3 details only when it is not practical to use Sheet 1 or 2 details.
4. Place 4 feet (minimum) of longitudinal channelizing devices along each side of existing sidewalk prior to the work zone or pedestrian diversion.
5. Within the TPAR, existing and proposed TCD placements shall meet Standard Plan S-05. Existing and proposed TCD features mounted lower than 7 feet above the finished surface shall not project more than 4 inches for a length of 24 inches (maximum) into the TPAR. Reduced width of the TPAR shall be separated by 48 inches long (minimum) and 36 inches wide (minimum) segments. Construction materials shall not protrude into the useable width of the TPAR. When necessary to meet these requirements, use an approved temporary sign support.
6. Refer to sign size table on Sheet 4.

**DIVERSION AWAY FROM ROADWAY TYPICAL APPLICATION DETAILS NOTES:**

- A. Throughout the entire length of the TPAR diversion, maintain a minimum usable width of:
  - i) 48 inches when the existing pedestrian facility width is 48 inches or more.
  - ii) 36 inches when the existing pedestrian facility width is less than 48 inches.

If the TPAR diversion width is less than 60 inches, provide a 60 x 60-inch passing space at least every 200 feet to allow individuals in wheelchairs to pass. When it is not possible to maintain a minimum passing space, use an alternate route.

If the TPAR diversion grade exceeds 5%, construct a ramp as needed meeting the requirements of Section 405 of the 2006 ADA Standards for Transportation Facilities. The TPAR diversion when contained within the roadway right-of-way may have a grade exceeding 5% but must be less than or equal to the adjacent roadway grade.
- B. When a crosswalk is closed at signalized intersections, cover corresponding pedestrian traffic signal display(s).
- C. Where noted, install pedestrian signs on Type III barricades or longitudinal channelizing devices.

State of Alaska DOT&PF  
ALASKA STANDARD PLAN  
TEMPORARY PEDESTRIAN  
ACCESSIBLE ROUTES

Adopted as an Alaska Standard Plan by:

Lauren Little, P.E.  
Interim Chief Engineer

Adoption Date: 01/29/2024

Last Code and Sds. Review  
By: ZSH Date: 12/18/2023

Next Code and Standards Review Date: 12/18/2033

C-03.30

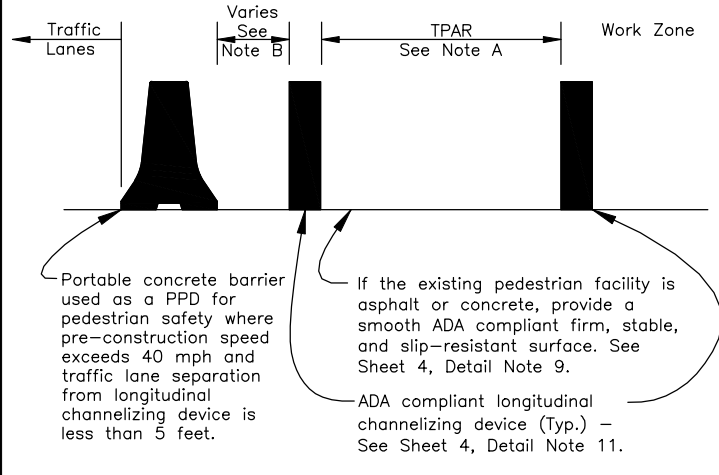

PEDESTRIAN DIVERSION TYPICAL SECTION

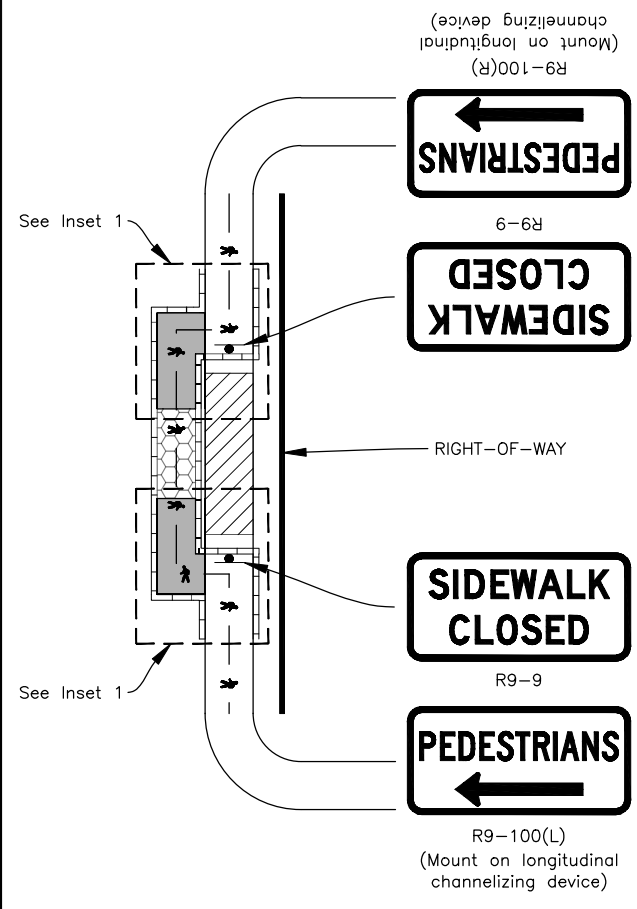

Mid-Block

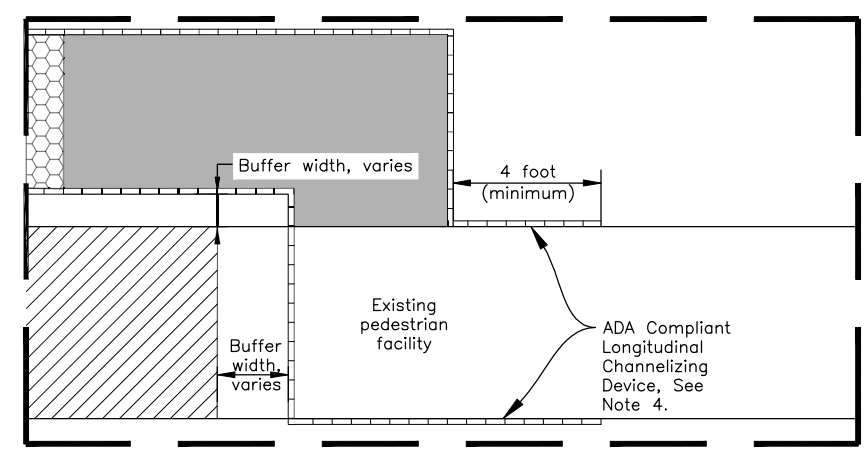

Inset "1"

SIDEWALK, PATHWAY, OR SHOULDER CLOSURE:  
DIVERSION IN ROADWAY  
TYPICAL APPLICATION DETAILS

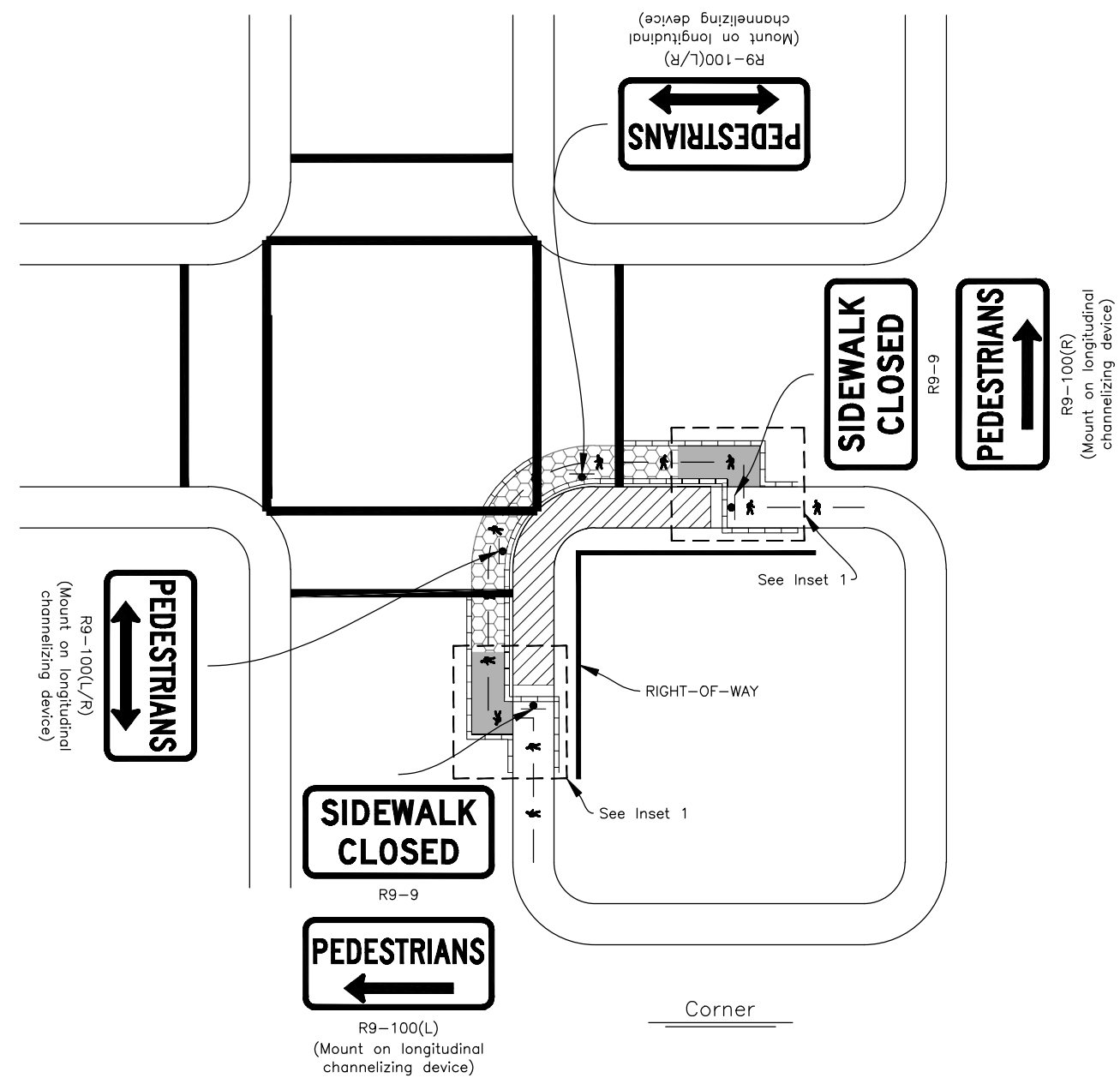

**LEGEND:**

	ADA Compliant Longitudinal Channelizing Device
	Temporary Pedestrian Accessible Route Diversion
	Temporary Pedestrian Accessible Route
	Work Zone
	Sign
	Temporary Curb Ramp (See Note C)

**GENERAL NOTES FOR TYPICAL APPLICATION DETAILS:**

1. Only traffic control devices (TCD) for pedestrians are shown. Other TCD may be necessary to control vehicular traffic.
2. Provide longitudinal channelizing devices when sidewalks or pathways are closed to pedestrians and where required by the Plans or Specifications. When pre-construction project conditions are disrupted, closed, or relocated in a temporary traffic control zone, the temporary pedestrian accessible route (TPAR) shall be detectable and include accessibility features consistent with the features present in the existing pedestrian facility.
3. Typical applications details depicted on Sheets 1 through 3 are in order of preference. Avoid unnecessary pedestrian routing detours. Use Sheet 3 details only when it is not practical to use Sheet 1 or 2 details.
4. Place 4 feet (minimum) of longitudinal channelizing devices along each side of existing sidewalk prior to the work zone or pedestrian diversion.
5. Within the TPAR, existing and proposed TCD placements shall meet Standard Plan S-05. Existing and proposed TCD features mounted lower than 7 feet above the finished surface shall not project more than 4 inches for a length of 24 inches (maximum) into the TPAR. Reduced width of the TPAR shall be separated by 48 inches long (minimum) and 36 inches wide (minimum) segments. Construction materials shall not protrude into the useable width of the TPAR. When necessary to meet these requirements, use an approved temporary sign support.
6. Refer to sign size table on Sheet 4.

**DIVERSION IN ROADWAY TYPICAL APPLICATION DETAILS NOTES:**

- A. Throughout the entire length of the TPAR diversion, maintain a minimum usable width of:
    - i) 48 inches when the existing pedestrian facility width is 48 inches or more.
    - ii) 36 inches when the existing pedestrian facility width is less than 48 inches.
- If the TPAR diversion width is less than 60 inches, provide a 60 x 60-inch passing space at least every 200 feet to allow individuals in wheelchairs to pass. When it is not possible to maintain a minimum passing space, use an alternate route.
- If the TPAR diversion grade exceeds 5%, construct a ramp as needed meeting the requirements of Section 405 of the 2006 ADA Standards for Transportation Facilities.
- B. Where the pre-construction posted speed limit exceeds 40 mph, separate the longitudinal channelizing devices from the traffic lane by at least 5 feet. Where that is not feasible, install portable concrete barriers as a positive protection device (PPD) between the longitudinal channelizing devices and the traffic lane, meeting the deflection buffer requirements stated on Standard Plan G-47. See pedestrian diversion typical section.
- C. Place or construct temporary curb ramp as needed. Curb ramp must meet ADA requirements, see Sheet 4.

State of Alaska DOT&PF  
ALASKA STANDARD PLAN  
TEMPORARY PEDESTRIAN  
ACCESSIBLE ROUTES

Adopted as an Alaska Standard Plan by:   
Lauren Little, P.E.  
Interim Chief Engineer

Adoption Date: 01/29/2024

Last Code and Sids. Review  
By: ZSH Date: 12/18/2023

Next Code and Standards Review Date: 12/18/2033

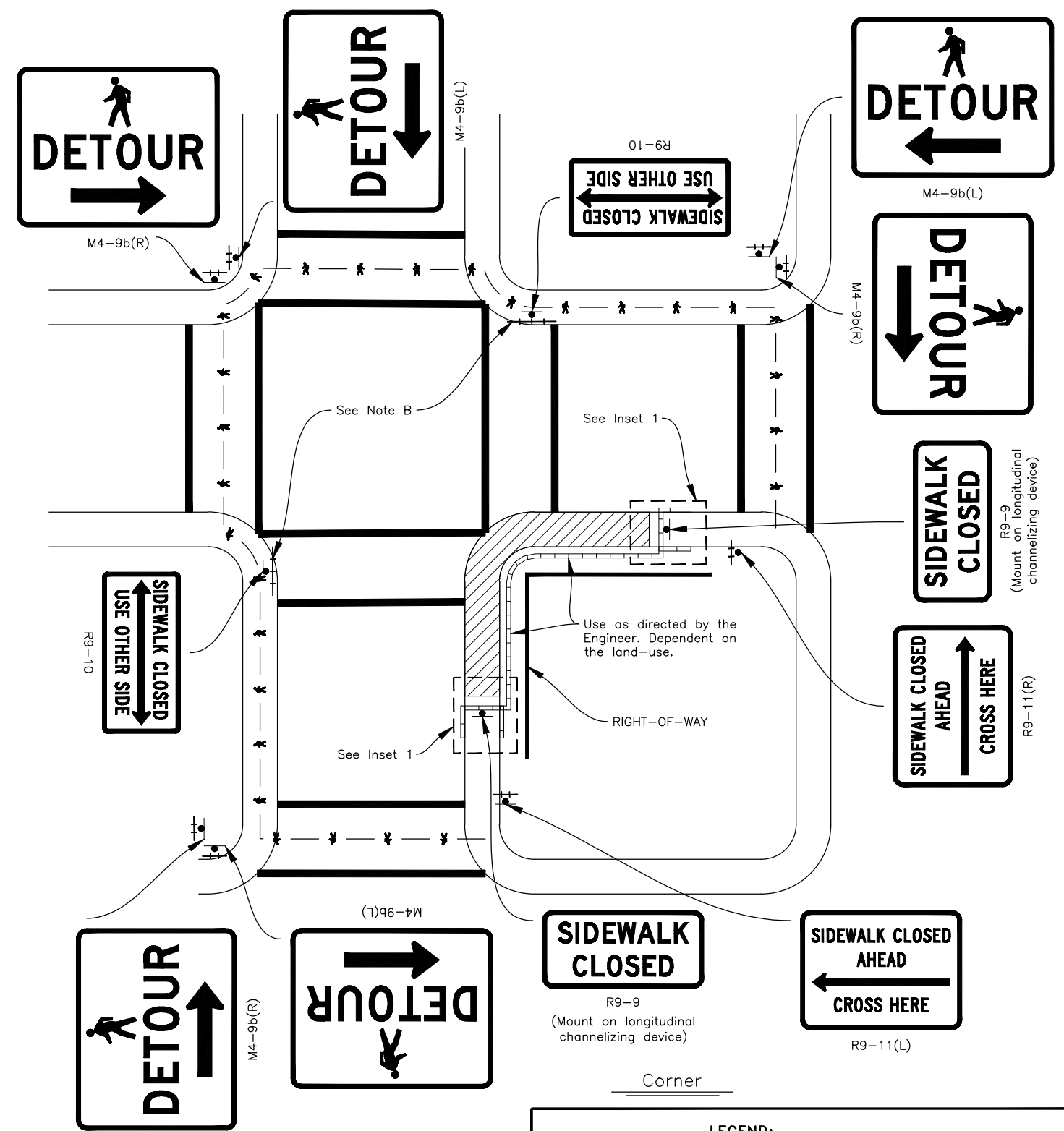
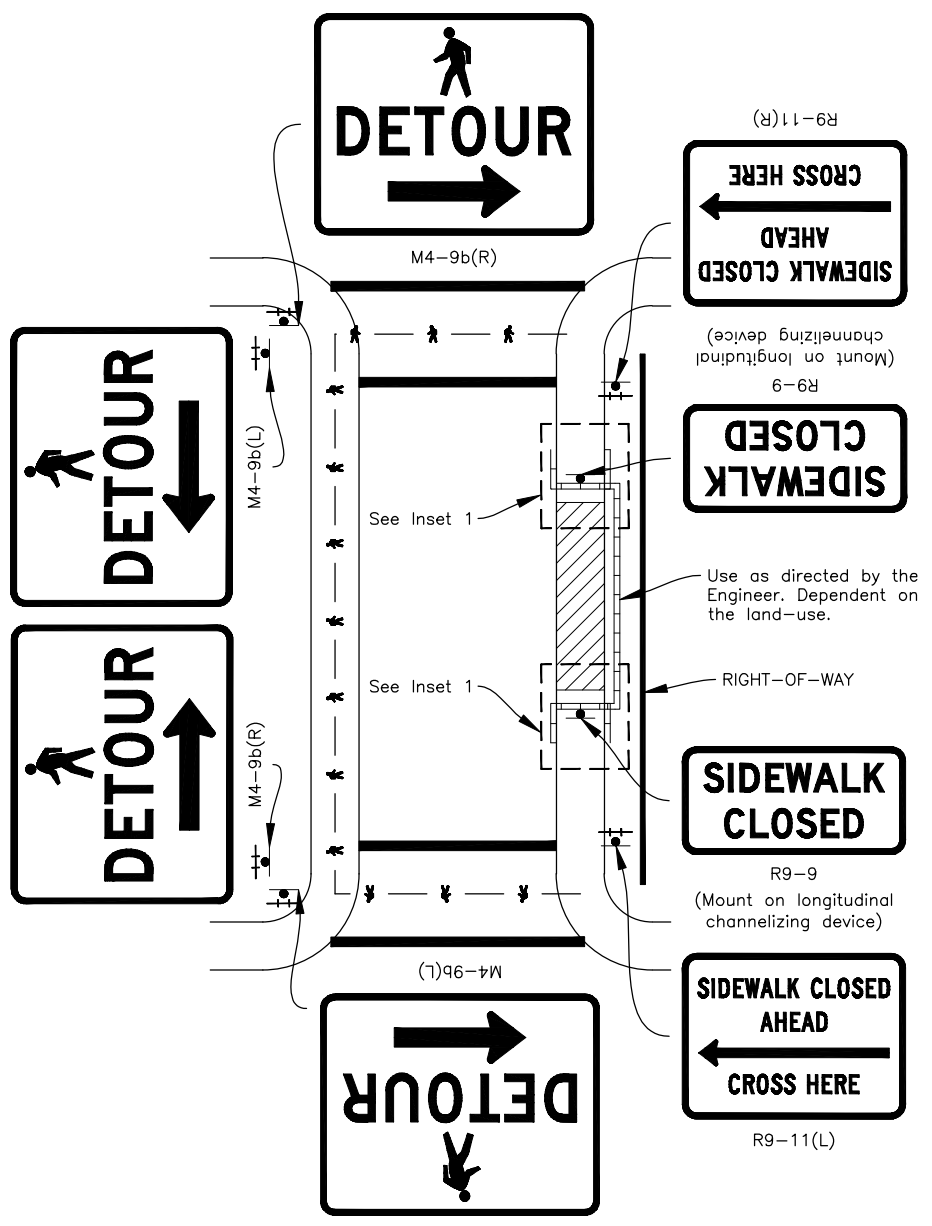
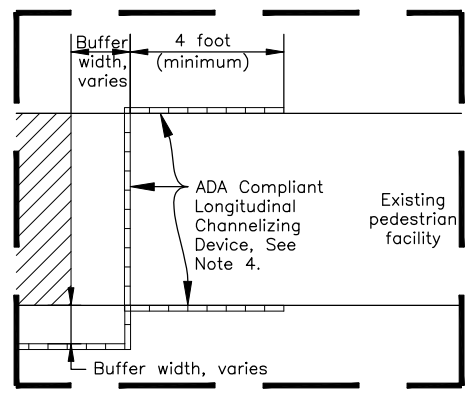

SIDEWALK, PATHWAY, OR SHOULDER CLOSURE:  
DETOUR ACROSS ROADWAY  
TYPICAL APPLICATION DETAILS

**GENERAL NOTES FOR TYPICAL APPLICATION DETAILS:**

1. Only traffic control devices (TCD) for pedestrians are shown. Other TCD may be necessary to control vehicular traffic.
2. Provide longitudinal channelizing devices when sidewalks or pathways are closed to pedestrians and where required by the Plans or Specifications. When pre-construction project conditions are disrupted, closed, or relocated in a temporary traffic control zone, the temporary pedestrian accessible route (TPAR) shall be detectable and include accessibility features consistent with the features present in the existing pedestrian facility.
3. Typical applications details depicted on Sheets 1 through 3 are in order of preference. Avoid unnecessary pedestrian routing detours. Use Sheet 3 details only when it is not practical to use Sheet 1 or 2 details.
4. Place 4 feet (minimum) of longitudinal channelizing devices along each side of existing sidewalk prior to the work zone or pedestrian diversion.
5. Within the TPAR, existing and proposed TCD placements shall meet Standard Plan S-05. Existing and proposed TCD features mounted lower than 7 feet above the finished surface shall not project more than 4 inches for a length of 24 inches (maximum) into the TPAR. Reduced width of the TPAR shall be separated by 48 inches long (minimum) and 36 inches wide (minimum) segments. Construction materials shall not protrude into the useable width of the TPAR. When necessary to meet these requirements, use an approved temporary sign support.
6. Refer to sign size table on Sheet 4.

**DETOUR ACROSS ROADWAY TYPICAL APPLICATION DETAILS NOTES:**

- A. When a crosswalk is closed at signalized intersections, cover corresponding pedestrian traffic signal display(s).
- B. Where noted, install pedestrian signs on Type III barricades or longitudinal channelizing devices.
- C. Route pedestrians to the safest and closest crossing point near the work zone.
- D. Limit work to one corner at a time to minimize pedestrian disruption and detour length.

**LEGEND:**

	ADA Compliant Longitudinal Channelizing Device
	Temporary Pedestrian Accessible Route Diversion
	Temporary Pedestrian Accessible Route
	Work Zone
	Sign
	Type II Barricade
	Type III Barricade

State of Alaska DOT&PF  
ALASKA STANDARD PLAN  
TEMPORARY PEDESTRIAN  
ACCESSIBLE ROUTES

Adopted as an Alaska  
Standard Plan by:

Lauren Little, P.E.  
Interim Chief Engineer

Adoption Date: 01/29/2024

Last Code and Sds. Review  
By: ZSH Date: 12/18/2023

Next Code and Standards Review Date: 12/18/2033

C-03.30

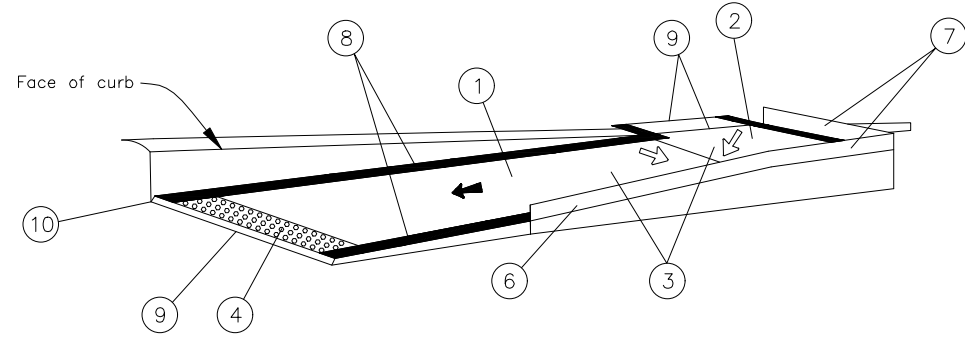

EXAMPLE TEMPORARY CURB RAMP, PARALLEL TO CURB

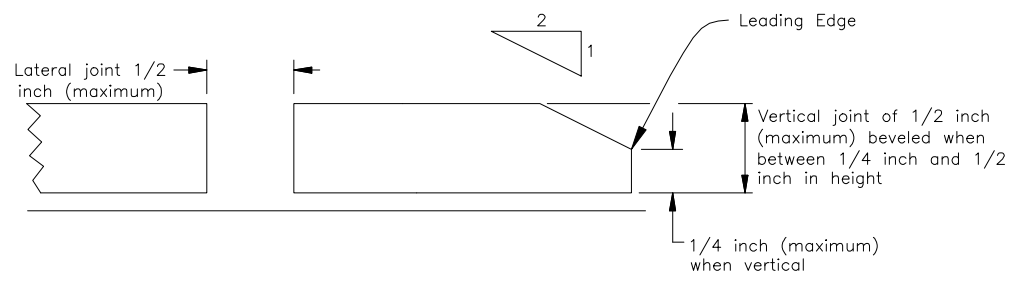

EDGE TREATMENT DETAIL

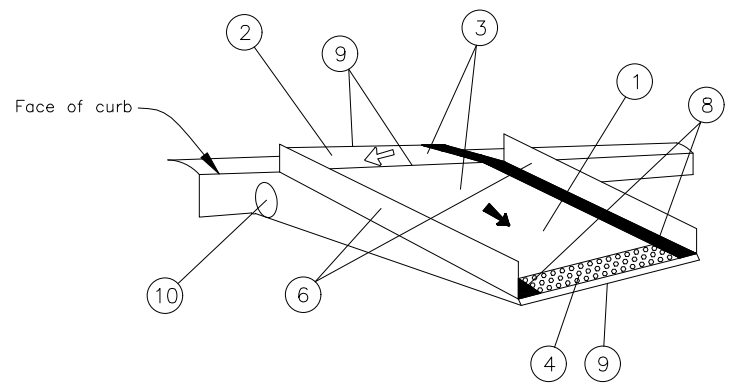

With Protective Edge

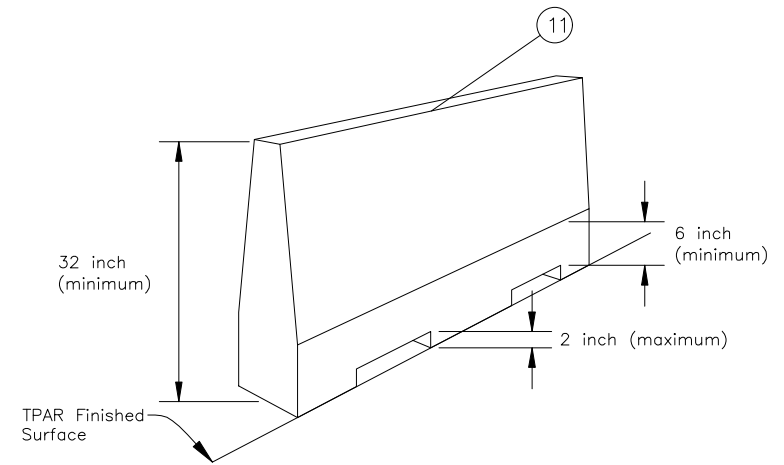

EXAMPLE LONGITUDINAL CHANNELIZING DEVICE DETAIL

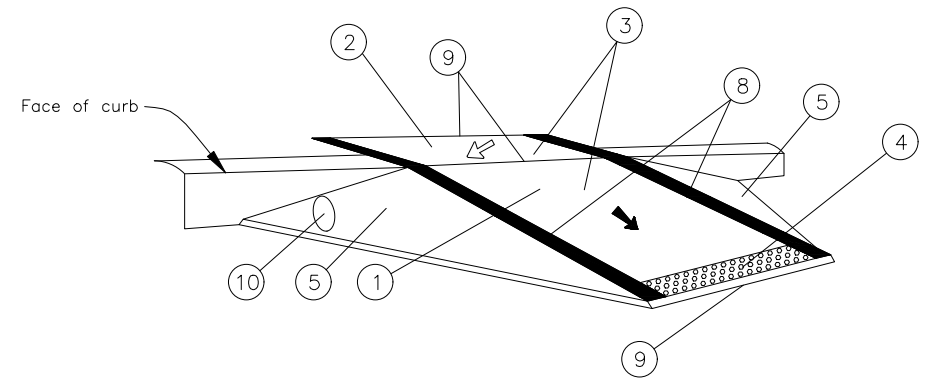

With Side Flares

Detectable edging are not required when meeting the requirements of Detail Note 6

EXAMPLE TEMPORARY CURB RAMP, PERPENDICULAR TO CURB

**GENERAL NOTES:**

1. The curb ramp shall be either self-ballasting or include an anchoring system capable of keeping the platform stationary under pedestrian traffic, including motorized wheelchairs.
2. The curb ramp platform shall be free of sharp, rough edges, or abrasive elements that may harm pedestrians.

**DETAIL NOTES:**

- ① Clear width per requirements stated in sheets 1 and 2, Note A.
- ② Landing shall be provided at the top of curb ramps. The landing clear length shall be 36 inches minimum. The landing clear width shall be at least as wide as the curb ramp (excluding flared sides, leading to the landing).
- ③ Ramps shall have a running slope of 8.3% maximum (7.7% nominal) and cross slope of 2.0% maximum (1.5% nominal). If the landing functions as a turning space, slope in any direction (including diagonal) of the turning space shall be 2.0% maximum (1.5% nominal).
- ④ Install detectable warning surface at pedestrian street crossings. The detectable warning shall extend the full width of the curb ramp (excluding flared sides) and shall be 24 inches (minimum) deep measured from the back of the curb on the ramp surface. Omit detectable warning surfaces at end of sidewalk transitions that are not at a crosswalk.
- ⑤ Curb ramp flares where provided shall have 10% maximum (8.3% nominal) slope.
- ⑥ Detectable edging with 6 inch (minimum) height shall be placed along the ramp run when there is a vertical drop exceeding 6 inches or is adjacent to a side slope exceeding 1:3 (vertical:horizontal).
- ⑦ Detectable edging with 6 inch (minimum) height and contrasting color shall be placed on all turning spaces where the walkway changes direction.
- ⑧ The curb ramp walkway edge shall be marked with a contrasting color, 4 inch wide stripe. The marking is optional where a contrasting detectable edging is used.
- ⑨ See edge treatment detail for requirements on lateral and vertical joints or gaps between surfaces. Surface slopes that meet at a grade break shall be flush.
- ⑩ Provide an approved means to maintain water flow along existing curb flow line and to prevent water from accumulating at the bottom of the ramp, or overflowing onto the ramp surface.
- ⑪ Where longitudinal channelizing devices are used to delineate a TPAR, continuous detectable top and bottom surfaces in compliance with the Alaska Traffic Manual shall be provided such that pedestrians using a long cane can follow it. The top of the top surface shall be at least 32 inches above the TPAR surface. The bottom surface shall be at least 6 inches in height with a gap no greater than 2 inches above the TPAR surface. Longitudinal channelizing devices shall be interlocked and not have gaps that allow pedestrians to stray from the channelizing path.

SIGN SIZE TABLE			
ALASKA SIGN DESIGN SPECIFICATIONS CODE	SIZE H X V (INCHES)		
R9-9	24	X	12
R9-10	24	X	12
R9-100(L/R), R9-100(L), R9-100(R)	24	X	12
R9-11(L), R9-11(R)	24	X	18
M4-9b(L), M4-9b(R)	30	X	24

**LEGEND:**

← Running slope

↔ Cross slope

▒ Detectable warning surface

State of Alaska DOT&PF  
ALASKA STANDARD PLAN  
**TEMPORARY PEDESTRIAN ACCESSIBLE ROUTES**

Adopted as an Alaska Standard Plan by:   
Lauren Little, P.E.  
Interim Chief Engineer

Adoption Date: 01/29/2024

Last Code and Sds. Review  
By: ZSH Date: 12/18/2023

Next Code and Standards Review Date: 12/18/2033

ANNULAR BAND				
BAND MATERIAL	PIPE DIA.	PIPE-ARCH SPAN x RISE (IN.)	BAND AND CONNECTOR WIDTH (W)	BOLT QUANTITY SEE NOTE 2
STEEL	12" - 30"	17x13 TO 35x24	12"	2
	36" - 72"	49x29 TO 83x57	24"	5/6, 10/12
	54" - 144" SEE NOTE 1	NOT APPROPRIATE		10/12, 15/18
ALUMINUM ALLOY	12" - 30"	17x13 TO 35x24	12"	3
	36" - 54"	42x29 TO 64x43	24"	5/6, 10/12
	36" - 96" SEE NOTE 1	NOT APPROPRIATE		

**ANNULAR BAND NOTES:**

1. TYPICALLY 3" X 1" OR 5" X 1" CORRUGATION SIZES.
2. STACKED BOLT QUANTITY INDICATES NUMBER OF BOLTS FOR ANGLE CONNECTORS THAT ARE ONE OR TWO PIECED. EX 5/6 USES 5 BOLTS FOR SINGLE ANGLE OR 6 BOLTS TOTAL FOR TWO PIECE ANGLE.
3. 8" CONNECTOR MAY BE USED WITH A 12" BAND ON 12"-30" STEEL PIPES.
4. NEOPRENE GASKET 12" WIDE X 3/8" THICK.
5. BOLTS ARE 1/2" X 6" MIN, 1/2" X 8" PREFERRED.

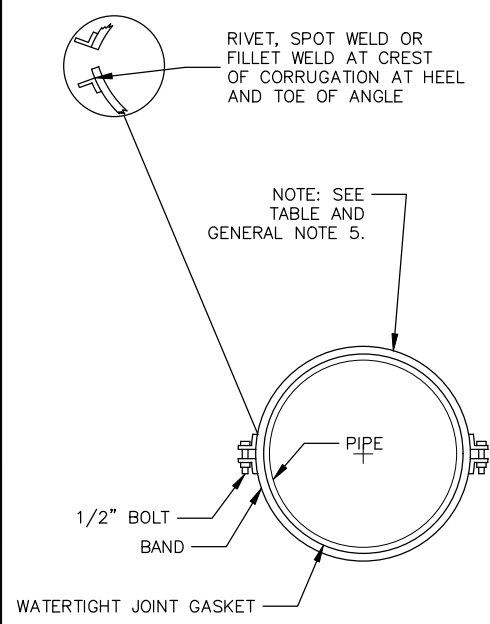

**ANGLE CONNECTOR DETAIL**

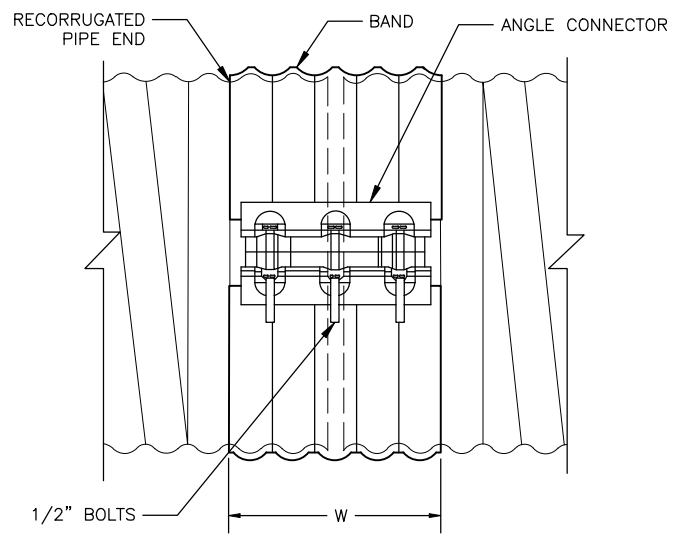

**ANNULAR BAND**

SPIRAL/HELICAL ANGLE BAND			
BAND MATERIAL	PIPE DIA.	BAND AND CONNECTOR WIDTH (W)	BOLT QUANTITY SEE NOTE 2
STEEL	12" - 30"	12"	3/6
	36" - 144" SEE NOTE 1	24"	5/6, 10/12, 15/18
ALUMINUM ALLOY	12" - 30"	12"	3/6
	36" - 54"	12"	5/6, 10/12
	36" - 96" SEE NOTE 1	24"	5/6, 10/12

**SPIRAL BAND NOTES:**

1. TYPICALLY 3" X 1" OR 5" X 1" CORRUGATION SIZES.
2. STACKED BOLT QUANTITY INDICATES NUMBER OF BOLTS FOR ANGLE CONNECTORS THAT ARE ONE OR TWO PIECED. EX 5/6 USES 5 BOLTS FOR SINGLE ANGLE OR 6 BOLTS TOTAL FOR TWO PIECE ANGLE.
3. NEOPRENE GASKET 12" WIDE X 3/8" THICK.
4. BOLTS ARE 1/2" X 6" MIN, 1/2" X 8" PREFERRED.

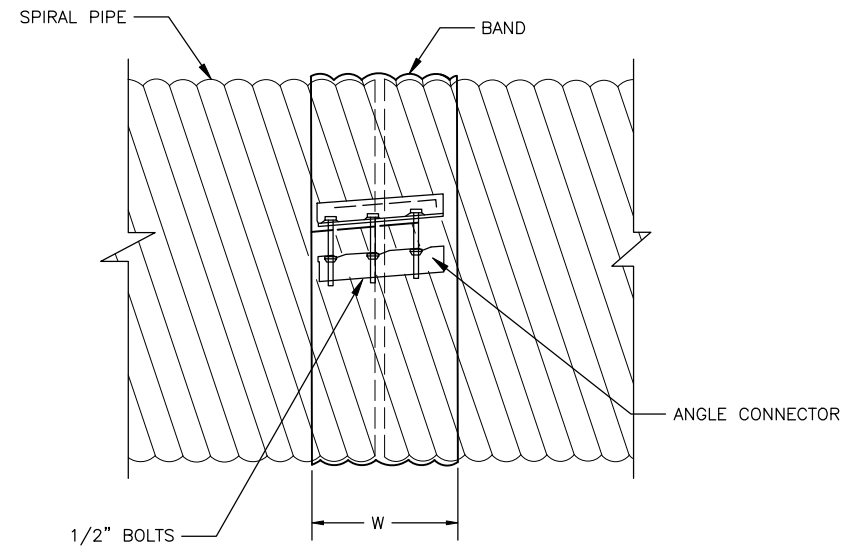

**SPIRAL BAND**

**CORRUGATED BANDS**

N.T.S.

SPIRAL/HELICAL BIAS BAND			
BAND MATERIAL	PIPE DIA.	BAND AND CONNECTOR WIDTH (W)	BOLT QUANTITY
STEEL	6" - 10"	7"	2
	12" - 18"	12"	3
ALUMINUM ALLOY	6" - 10"	7"	2
	12" - 18"	12"	3

**2-PIECE BIAS BAND NOTES:**

1. NEOPRENE GASKET 7" WIDE X 3/8" THICK.

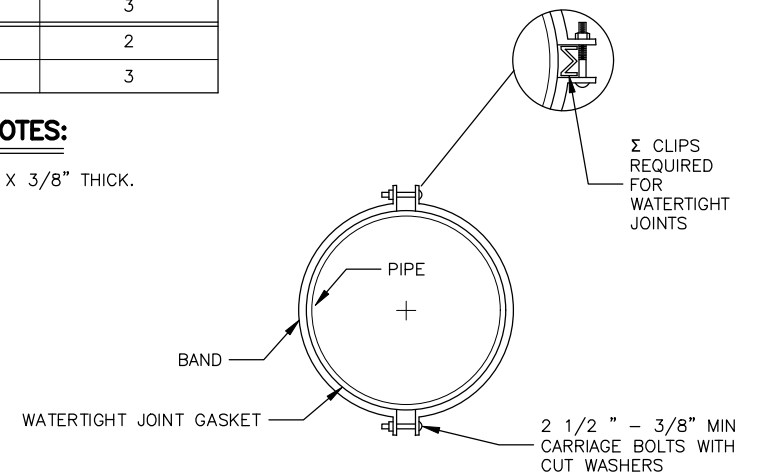

**BIAS BAND END VIEW**

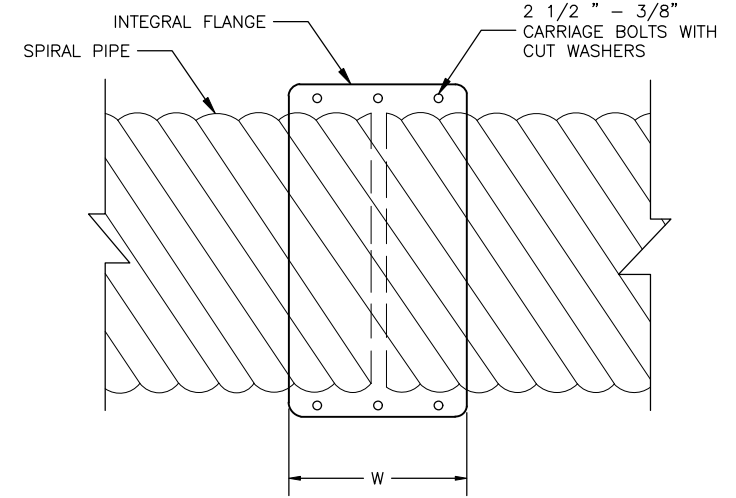

**2-PIECE BIAS BAND**

**GENERAL NOTES:**

1. ALL MATERIAL AND WORKMANSHIP SHALL BE IN ACCORDANCE WITH THE STATE OF ALASKA, STANDARD SPECIFICATIONS FOR HIGHWAY CONSTRUCTION, AND THE PROJECT SPECIAL PROVISIONS.
2. ALL NEOPRENE GASKETS ARE STRIP TYPE OR BUTT-CEMENTED OR VULCANIZED SLEEVE TYPE. MATERIAL MEETS ASTM SPECIFICATION D 1056, TYPE 2 (CLOSED CELL SPONGE), CLASS B, GRADE 3. O-RING GASKETS TO MEET SPECIFICATION ASTM C-443.
3. BAND ANGLE LENGTH IS NOMINAL AND IS GIVEN TO THE NEAREST INCH OF LENGTH. LENGTH OVER 12" MAY CONSIST OF MULTIPLE ANGLES OF SHORTER LENGTH.
4. BOLT QUANTITY VARIES WITH BAND WIDTH, DIAMETER, CONNECTION HARDWARE TYPE, AND NUMBER OF BAND SEGMENTS.
5. PROVIDE ONE-PIECE ANGLE CONNECTOR THRU 42" DIAMETER, 2-PIECE ANGLE CONNECTORS FOR DIAMETERS 48" THRU 90", AND THREE-PIECE ANGLE CONNECTORS FOR DIAMETERS 96" THRU 144", OR AS OTHERWISE REQUESTED.

State of Alaska DOT&PF  
ALASKA STANDARD PLAN  
**BAND COUPLER AND  
HARDWARE SCHEDULE**

Adopted as an Alaska Standard Plan by:   
Lauren Little, P.E.  
Interim Chief Engineer  
Adoption Date: 01/29/2024

Last Code and Sids. Review  
By: BMM Date: 12/13/2023  
Next Code and Standards Review Date: 12/13/2033

D-08.00

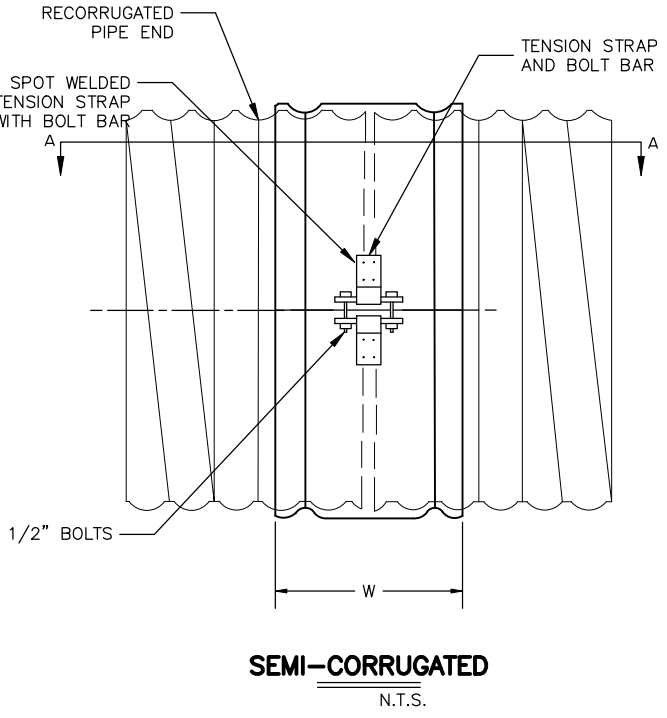
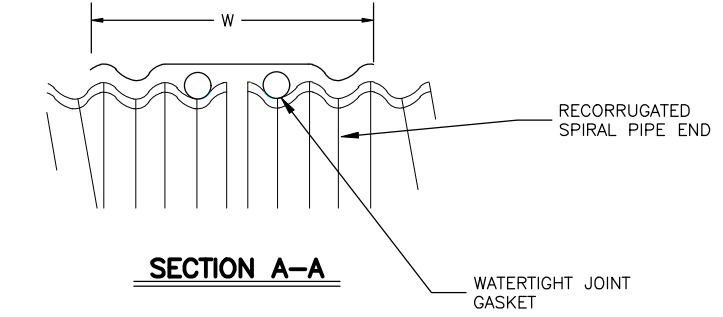
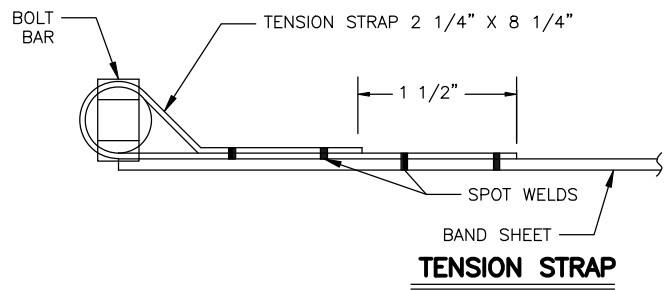

- SEMI-CORRUGATED BAND NOTES:**
1. ANNULAR PIPE WIDTH 2 2/3" X 1/2" CORRUGATIONS WIDTH IS 13 3/8", FOR 3"x1" CORRUGATIONS WIDTH IS 14 3/4"
  2. BOLTS ARE 1/2" X 6" MIN, 1/2" X 8" PREFERRED.
  3. ALTERNATE DESIGNS OF TENSIONS STRAPS ARE PERMISSIBLE IF TENSILE STRENGTH EXCEEDS 7500 LBS.

TYPE 1 BAND					
BAND MATERIAL	PIPE DIA.	PIPE-ARCH SPAN x RISE (IN.)	BAND WIDTH (W)	CONNECTOR WIDTH (W)	BOLT QUANTITY SEE NOTE 2
STEEL	12" - 30"	17x13 TO 35x24	10 1/2"	8"	2/4
	36" - 72"	49x29 TO 83x57	21"	20"	5/10
	54" - 144" SEE NOTE 1	NOT APPROPRIATE			10/15
ALUMINUM ALLOY	12" - 30"	17x13 TO 35x24	10 1/2"	8"	2/4
	36" - 54"	42x29 TO 64x43	21"	20"	5/6, 10/12
	54" - 96" SEE NOTE 1	NOT APPROPRIATE			

- TYPE 1 BAND NOTES:**
1. TYPICALLY 3" X 1" OR 5" X 1" CORRUGATION SIZES.
  2. STACKED BOLT QUANTITY INDICATES NUMBER OF BOLTS FOR ANGLE CONNECTORS THAT ARE ONE OR TWO PIECED. EX 2/4 USES 2 BOLTS FOR SINGLE ANGLE OR 4 BOLTS TOTAL FOR TWO PIECE ANGLE.
  3. NEOPRENE GASKET 12" WIDE X 3/8" THICK.
  4. O-RING GASKETS (APPLICABLE TO STEEL ONLY) ARE 13/16" FOR BANDS WITH PIPE DIAMETER THROUGH 72", AND 7/8" FOR PIPES WITH PIPE DIAMETER OVER 72".
  5. BOLTS ARE 1/2" X 6" MIN, 1/2" X 8" PREFERRED. ANGLE CONNECTOR

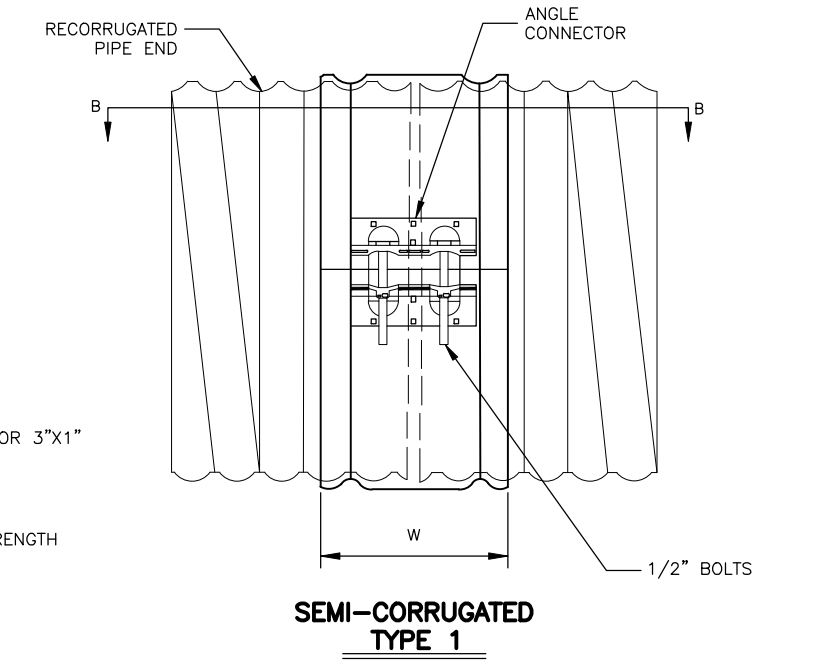
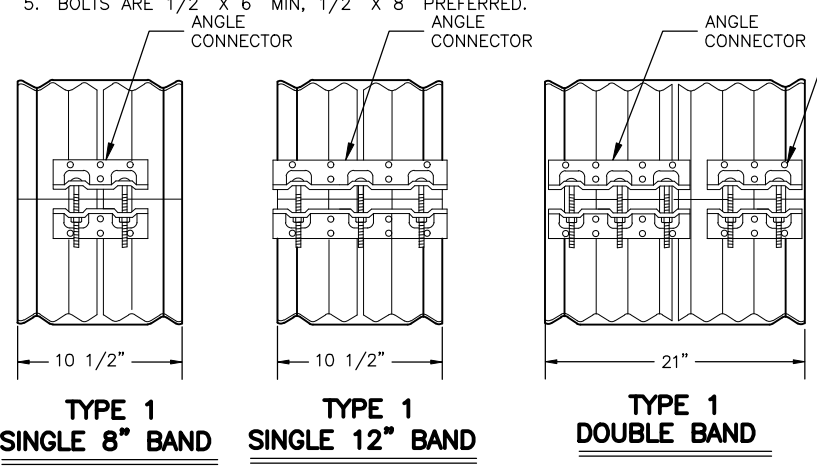

TYPE 2 BAND					
BAND MATERIAL	PIPE DIA.	PIPE-ARCH SPAN x RISE (IN.)	BAND WIDTH (W)	CONNECTOR WIDTH (W)	BOLT QUANTITY SEE NOTE 2
STEEL	12" - 30"	17x13 TO 35x24	10 1/2"	2.25"	2/4
	36" - 72"	49x29 TO 83x57	21"	2.25"x2"	4/8
	54" - 144" SEE NOTE 1	NOT APPROPRIATE			8/12
ALUMINUM ALLOY	12" - 30"	17x13 TO 35x24	10 1/2"	2.25"	2/4
	36" - 54"	42x29 TO 64x43	21"	2.25"x2"	5/6, 10/12
	54" - 96" SEE NOTE 1	NOT APPROPRIATE			

- TYPE 2 BAND NOTES:**
1. TYPICALLY 3" X 1" OR 5" X 1" CORRUGATION SIZES.
  2. STACKED BOLT QUANTITY INDICATES NUMBER OF BOLTS FOR ANGLE CONNECTORS THAT ARE ONE OR TWO PIECED. EX 2/4 USES 2 BOLTS FOR SINGLE ANGLE OR 4 BOLTS TOTAL FOR TWO PIECE ANGLE.
  3. NEOPRENE GASKET 12" WIDE X 3/8" THICK.
  4. O-RING GASKETS (APPLICABLE TO STEEL ONLY) ARE 13/16" FOR BANDS WITH PIPE DIAMETER THROUGH 72", AND 7/8" FOR PIPES WITH PIPE DIAMETER OVER 72".
  5. BOLTS ARE 1/2" X 6" MIN, 1/2" X 8" PREFERRED. BAR & STRAP CONNECTOR

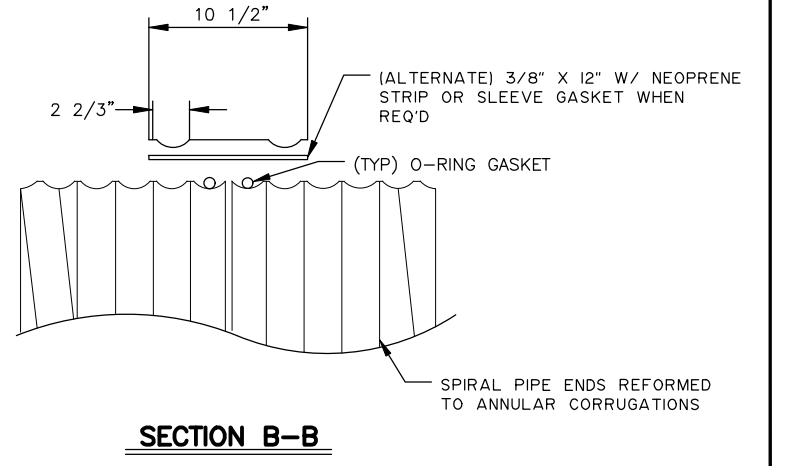
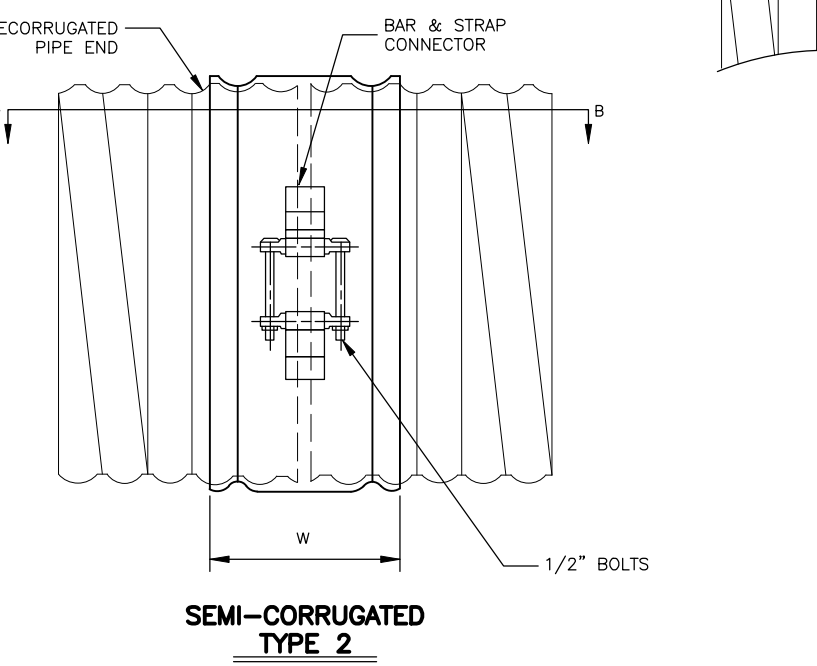
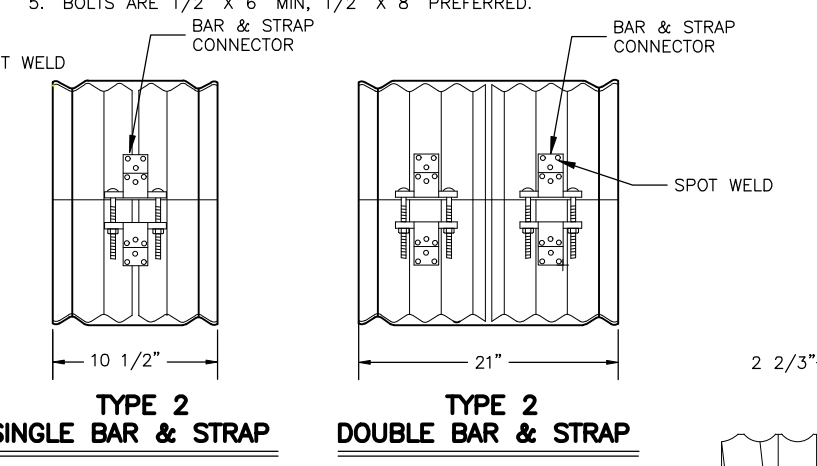

**SEMI-CORRUGATED BANDS (TYPE 1 & 2)**  
N.T.S.

State of Alaska DOT&PF  
ALASKA STANDARD PLAN

**BAND COUPLER AND  
HARDWARE SCHEDULE**

Adopted as an Alaska Standard Plan by:   
Lauren Little, P.E.  
Interim Chief Engineer

Adoption Date: 01/29/2024

Last Code and Sids. Review  
By: BMM Date: 12/13/2023

Next Code and Standards Review Date: 12/13/2033

D-08.00

DIMPLE BAND				
BAND MATERIAL	PIPE DIA.	PIPE-ARCH SPAN x RISE (IN.)	BAND AND CONNECTOR WIDTH (W)	BOLT QUANTITY SEE NOTE 2
STEEL	12" - 30"	17x13 TO 35x24	12"	3/6
	36" - 72"	49x29 TO 83x57	24"	5/6, 10/12
	54" - 144" SEE NOTE 1	42x29 TO 171x110		10/12, 15/18
ALUMINUM ALLOY	12" - 30"	17x13 TO 35x24	12"	3/6
	36" - 54"	42x29 TO 64x43	24"	5/6, 10/12
	36" - 96" SEE NOTE 1	60x46 TO 112x75		

**DIMPLE BAND NOTES:**

1. TYPICALLY 3" X 1" OR 5" X 1" CORRUGATION SIZES.
2. STACKED BOLT QUANTITY INDICATES NUMBER OF BOLTS FOR ANGLE CONNECTORS THAT ARE ONE OR TWO PIECED. EX 3/6 USES 3 BOLTS FOR SINGLE ANGLE OR 6 BOLTS TOTAL FOR TWO PIECE ANGLE.
3. DIMPLE BANDS ARE RESTRICTED TO JOINING FIELD CUT PIPE, EXTENSIONS OF EXISTING PIPE WITH SPIRAL ENDS, AND 3X1 OR 5X1 CORRUGATION PIPE-ARCHES.
4. NEOPRENE GASKET 12" WIDE X 3/8" THICK EXCEPT 1" THICK REQUIRED ON SPIRAL ENDS WITH 1" DEEP CORRUGATIONS.

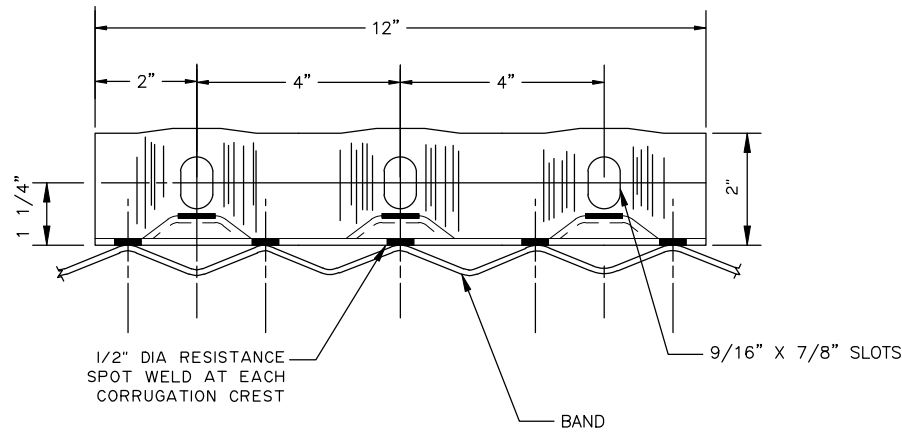

**SIDE VIEW**

ROD AND LUG BAND				
CORRUGATION	PIPE DIA.	BAND WIDTH (W)	ROD DIAMETER (IN.)	ROD QUANTITY SEE NOTE 2
2 3/4" X 1/2"	12" - 21"	12"	3/8"	2
	24" - 54"	12" OR 24"	1/2"	2/4
	60" - 84"	12" OR 24"	5/8"	2/4
3" X 1"	36" - 54"	14" OR 26"	1/2"	2/4
	60" - 84"	14" OR 26"	5/8"	2/4
	84" - 120"	26"	5/8"	4

**ROD AND LUG NOTES:**

1. PROVIDE WIDER BAND UNLESS OTHERWISE SPECIFIED.
2. STACKED ROD QUANTITY INDICATES NUMBER OF RODS FOR NARROW OR WIDE BANDS. EX 2/4 USES 2 RODS FOR NARROW BAND OR 4 RODS TOTAL FOR WIDE BANDS.

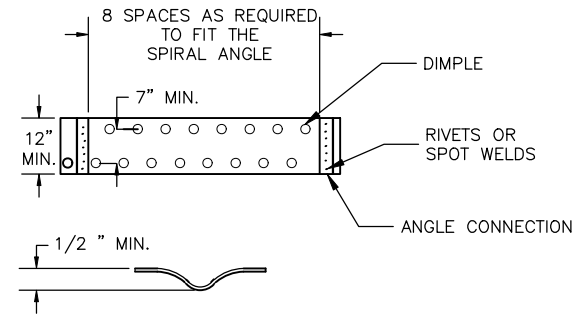

**DIMPLE SECTION**

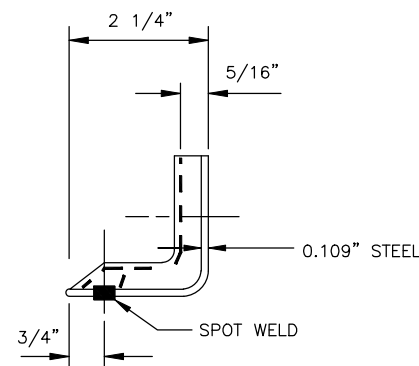

**END VIEW**

**ANGLE CONNECTION DETAILS**

N.T.S.

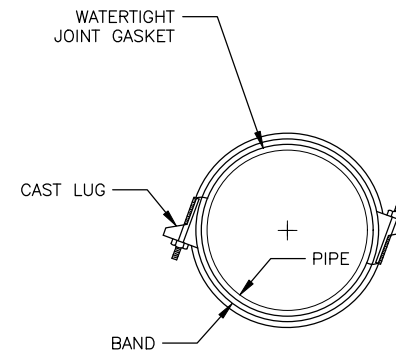

**END VIEW**

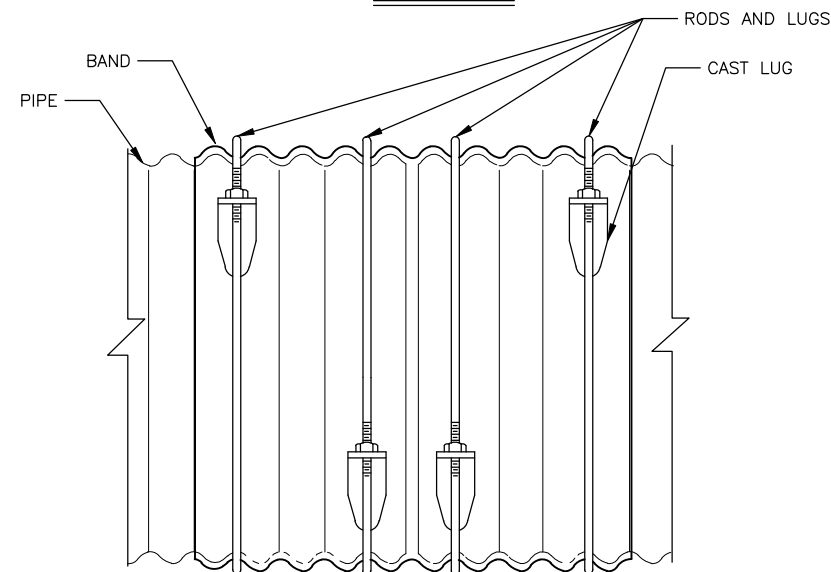

**ROD AND LUG BAND DETAILS**

N.T.S.

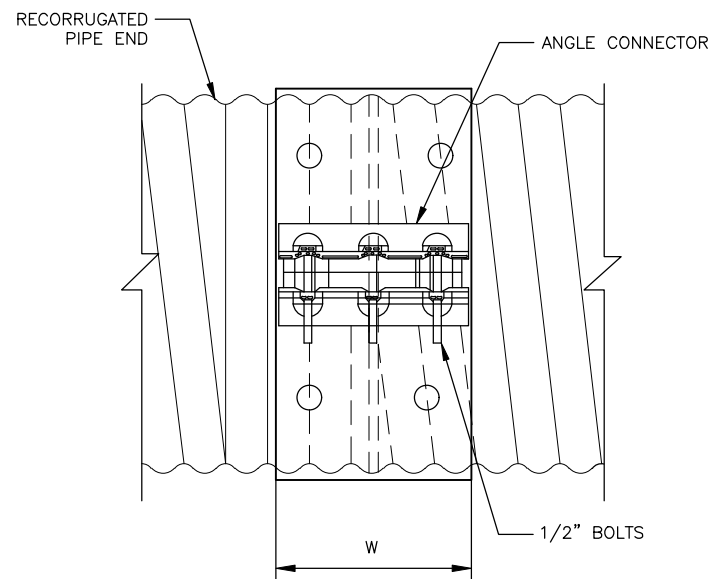

**DIMPLE BAND DETAILS**

N.T.S.

State of Alaska DOT&PF  
ALASKA STANDARD PLAN  
BAND COUPLER AND  
HARDWARE SCHEDULE

Adopted as an Alaska  
Standard Plan by:

Lauren Little, P.E.  
Interim Chief Engineer

Adoption Date: 01/29/2024

Last Code and Sids. Review  
By: BMM Date: 12/13/2023

Next Code and Standards Review Date: 12/13/2033

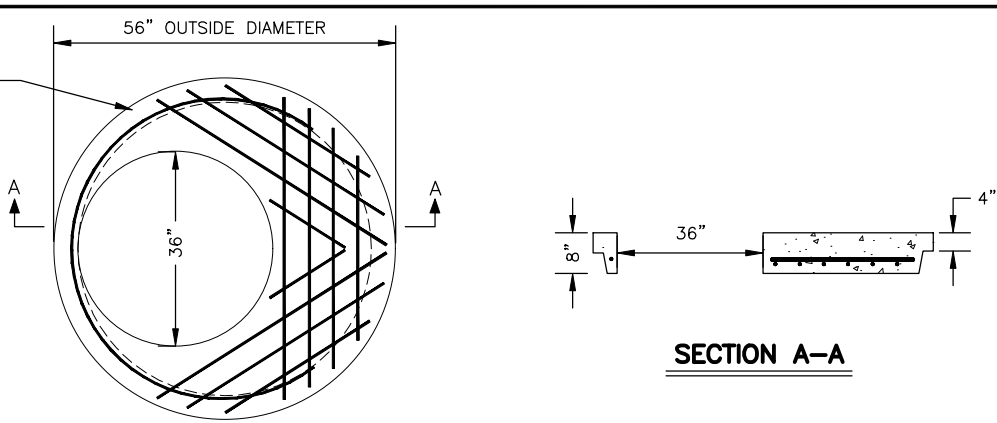
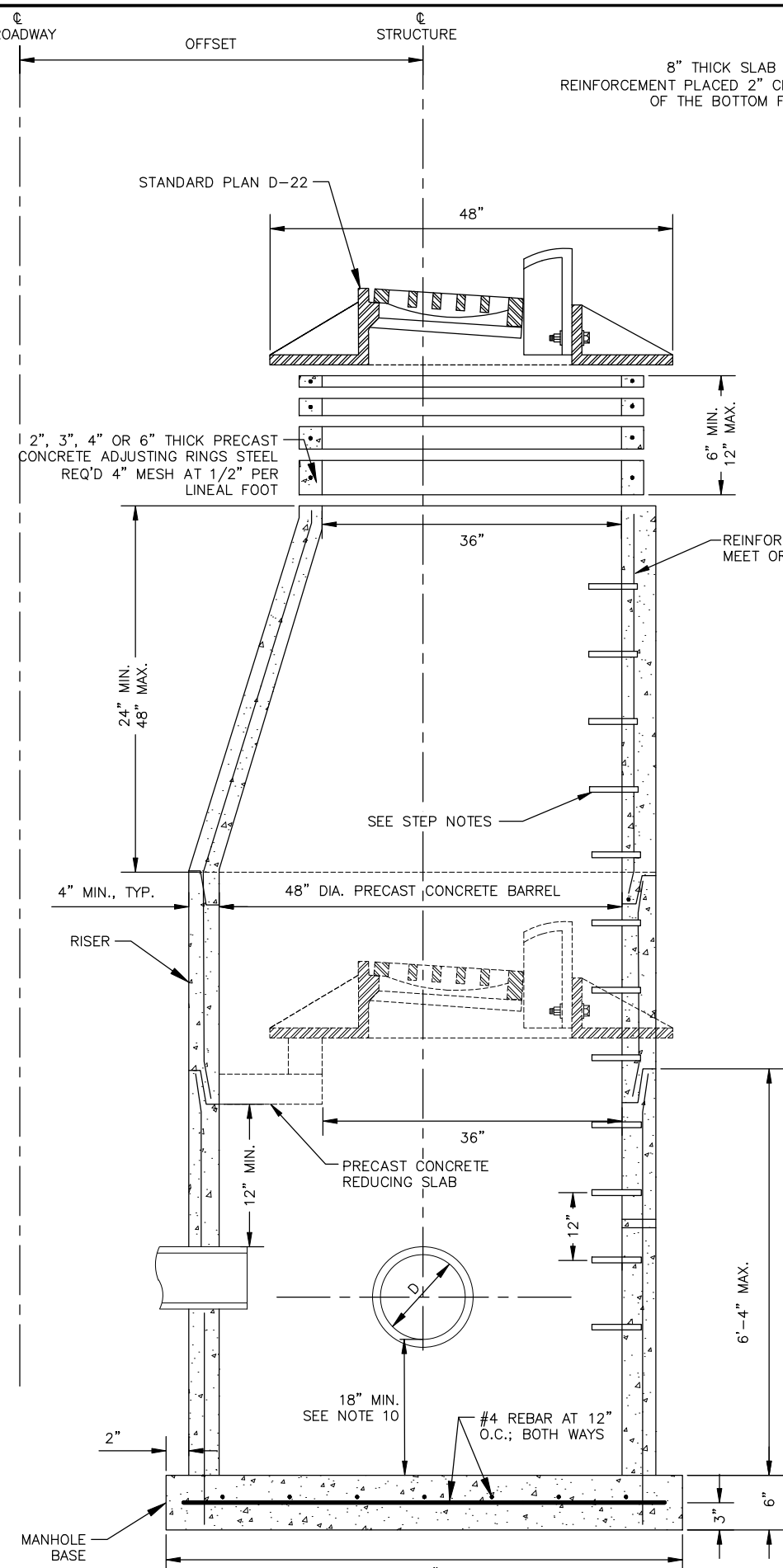

**PRECAST CONCRETE REDUCING SLAB (48" TO 36")**  
N.T.S.

**MANHOLE STEP NOTES:**

1. MEET CURRENT OSHA STANDARDS FOR STEPS AND ACCESS OPENINGS.
2. PLACE STEPS 12" O.C. ON AN UNOBSTRUCTED SIDE OF THE STRUCTURE, 18" MAXIMUM FROM MANHOLE BASE. IF UNOBSTRUCTED SIDE NOT AVAILABLE, PLACE BOTTOM STEP 6" OVER SMALLEST PIPE. WHEN USING A CONE, FIRST LADDER RUNG IS 8" MAXIMUM FROM TOP OF CONE. WHEN USING A FLAT LID, FIRST LADDER RUNG IS 4" MAXIMUM FROM TOP OF RISER.
3. PROVIDE INJECTION MOLDED POLYPROPYLENE COVERED GRADE 60 STEEL STEPS TIGHTLY IMBEDDED AT LEAST 3" INTO CONCRETE.
4. INSTALL STEPS TO RESIST A PULLOUT FORCE OF 1500 LB.
5. THE MINIMUM DIAMETER OF CLEAR ACCESS TO STEPS IS 24".
6. THE CONTRACTOR SHALL TAKE SPECIAL CARE FOR ANY MANHOLE THAT FALLS IN A CURB LINE TO SEE THAT WHEN MANHOLE IS OFFSET DURING INSTALLATION THAT THE STEPS FALL UNDER THE CURB INLET.

**REDUCING SLAB NOTES:**

1. SPACE ALL REBAR AT 6" CENTERS UNLESS OTHERWISE NOTED.
2. MAINTAIN A MINIMUM OF 1 1/2" OF CONCRETE COVER OVER ALL REBAR.
3. REINFORCING STEEL SHOWN IS A MINIMUM PER ASTM C478. PRECAST MFR TO COMPLETE AND SUBMIT SHOP DRAWINGS AND CALCULATIONS FOR ENGINEER'S REVIEW.

**GENERAL NOTES:**

1. THESE DRAWINGS ARE FOR PRECAST REINFORCED CONCRETE FOR HIGHWAY USE. CAST IN PLACE STRUCTURES MAY BE USED AS APPROVED BY THE ENGINEER.
2. MEET THE REQUIREMENTS OF ASTM C-478 FOR ALL DRAINAGE STRUCTURES AND APPURTENANCES.
3. MINIMUM STEEL REQUIRED FOR BARREL AS PER ASTM C-478 SHALL BE IMBEDDED IN BASE SO THAT THE FIRST BARREL SECTION IS CONNECTED TO THE BASE BY CONTINUOUS STEEL. PROVIDE REINFORCING STEEL TYPE AND GRADE PER DOT&PF STANDARD SPECIFICATIONS.
4. USE CLASS A OR CLASS B CONCRETE PER DOT&PF STANDARD SPECIFICATIONS.
5. SEAL RISER JOINTS WITH FLEXIBLE PLASTIC JOINT SEALERS.
6. PROVIDE NON-SHRINK GROUT. PROTECT GROUT DURING CURE IN ACCORDANCE WITH THE MANUFACTURER'S RECOMMENDED METHOD.
7. FORM ALL BLOCK-OUTS.
8. MANHOLE SHALL HAVE A MINIMUM OF ONE 6" GRADE RING.
9. ALL STORM DRAIN MANHOLES AND INLETS SHALL HAVE 18" MINIMUM SUMPS. MANHOLES WITH PETROLEUM SEPARATORS SHALL HAVE 24" MINIMUM SUMPS.
10. OFFSET IS MEASURED TO CENTERLINE OF STRUCTURE.
11. EXTEND PIPE 2" INTO MANHOLE. SEAL PIPE PENETRATIONS WITH NON-SHRINKABLE GROUT MIXED WITH POTABLE WATER PER MANUFACTURER'S RECOMMENDATIONS.
12. CATCH BASIN LEADS SHALL ENTER THE MANHOLE AT LEAST ONE PRIMARY LEAD DIAMETER ABOVE THE TOP OF THE PRIMARY LEAD UNLESS MINIMUM PIPE SLOPES CANNOT BE ACHIEVED.
13. MAXIMUM PIPE DIAMETER SHALL NOT EXCEED HALF OF THE STRUCTURE DIAMETER. PRIMARY LEADS MUST BE A MINIMUM OF 135 DEGREES APART.
14. USE 72" STORM DRAIN MANHOLE OR LARGER WHEN BOTH CATCH BASIN AND ACCESS FUNCTIONS ARE REQUIRED.
15. LIVE LOAD FOR DESIGN OF THE MANHOLE BARRELS, RISERS AND REDUCING SLABS IS AASHTO HL-93 (HS20 AND DESIGN TANDEM AXLE/WHEEL LOADS).
16. A FLAT LID WITH A SMALLER OPENING MAY ALSO BE USED IF CALLED FOR IN THE PLANS.

**STORM DRAIN MANHOLE, TYPE I**  
N.T.S.

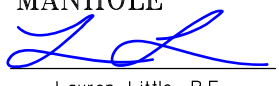
State of Alaska DOT&PF  
ALASKA STANDARD PLAN  
48" STORM DRAIN MANHOLE  
(PRECAST CONCRETE)  
TYPE I MANHOLE  
Adopted as an Alaska  
Standard Plan by:   
Lauren Little, P.E.  
Interim Chief Engineer  
Adoption Date: 01/29/2024

Last Code and Sids. Review  
By: BMM Date: 12/13/2023  
Next Code and Standards Review Date: 12/13/2033

D-35.10



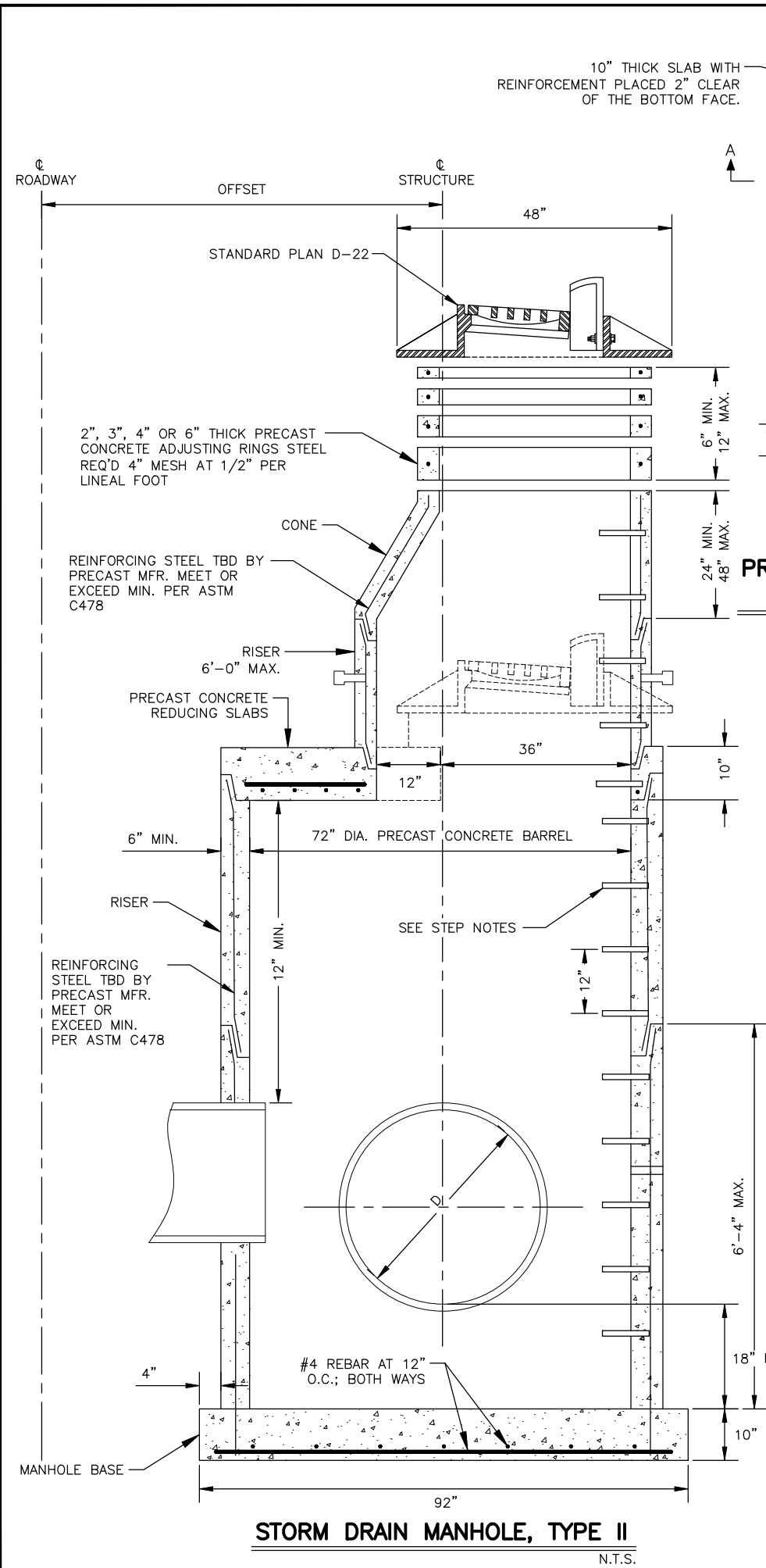

**STORM DRAIN MANHOLE, TYPE II**  
N.T.S.

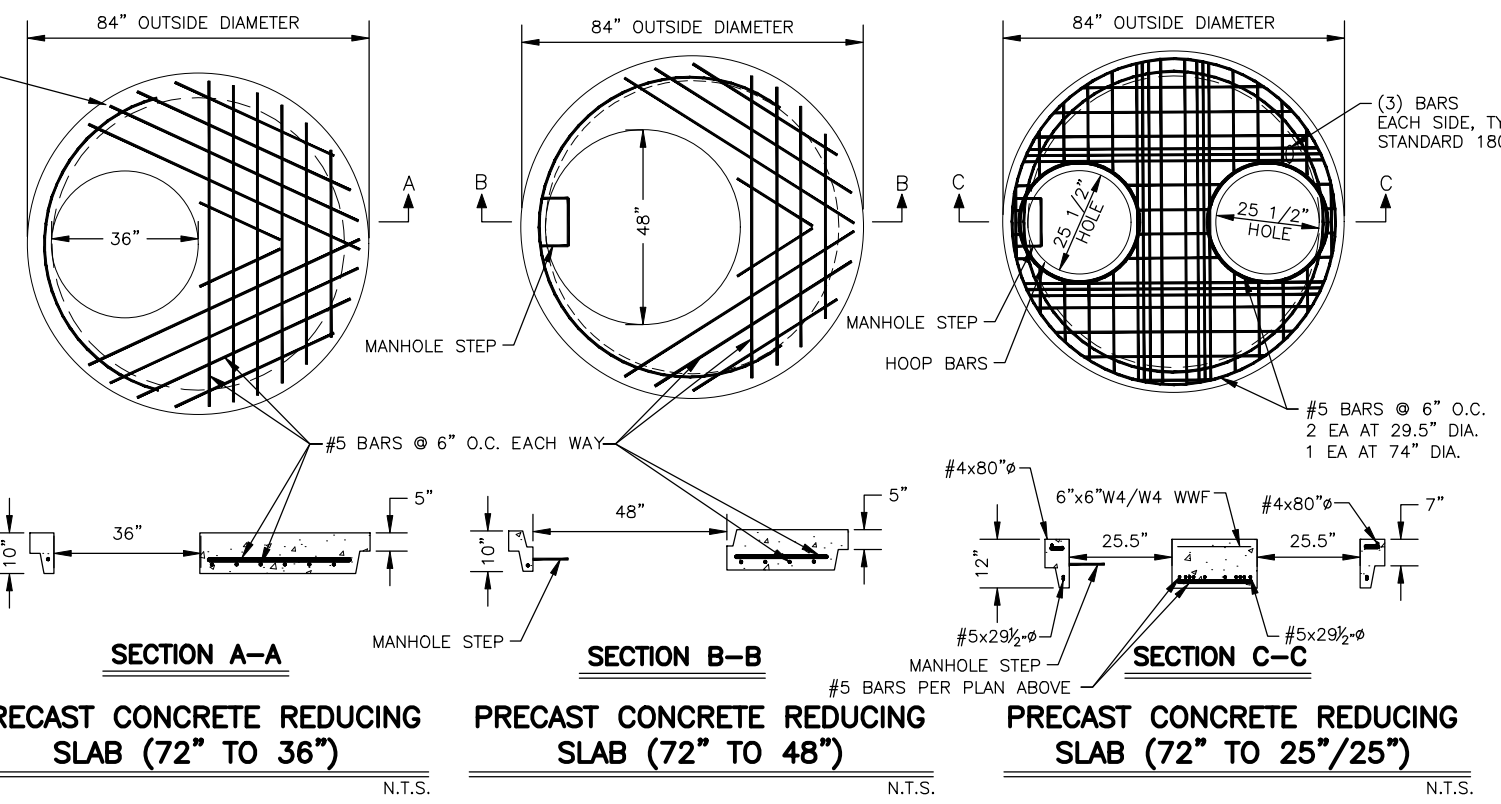

**PRECAST CONCRETE REDUCING SLAB (72" TO 36")**  
N.T.S.

**PRECAST CONCRETE REDUCING SLAB (72" TO 48")**  
N.T.S.

**PRECAST CONCRETE REDUCING SLAB (72" TO 25"/25")**  
N.T.S.

**GENERAL NOTES:**

1. THESE DRAWINGS ARE FOR PRECAST REINFORCED CONCRETE FOR HIGHWAY USE. CAST IN PLACE STRUCTURES MAY BE USED AS APPROVED BY THE ENGINEER.
2. MEET THE REQUIREMENTS OF ASTM C-478 FOR ALL DRAINAGE STRUCTURES AND APPURTENANCES.
3. MINIMUM STEEL REQUIRED FOR BARREL AS PER ASTM C-478 SHALL BE IMBEDDED IN BASE SO THAT THE FIRST BARREL SECTION IS CONNECTED TO THE BASE BY CONTINUOUS STEEL. PROVIDE REINFORCING STEEL TYPE AND GRADE PER DOT&PF STANDARD SPECIFICATIONS.
4. CONCRETE TO HAVE 1 1/2" MINIMUM COVER.
5. USE CLASS A OR CLASS B CONCRETE PER DOT&PF STANDARD SPECIFICATIONS.
6. SEAL RISER JOINTS WITH FLEXIBLE PLASTIC JOINT SEALERS.
7. PROVIDE NON-SHRINK GROUT. PROTECT GROUT DURING CURE IN ACCORDANCE WITH THE MANUFACTURER'S RECOMMENDED METHOD.
8. FORM ALL BLOCK-OUTS.
9. MANHOLE SHALL HAVE A MINIMUM OF ONE 6" GRADE RING.
10. ALL STORM DRAIN MANHOLES AND INLETS SHALL HAVE 18" MINIMUM SUMPS. MANHOLES WITH PETROLEUM SEPARATORS SHALL HAVE 24" MINIMUM SUMPS.
11. OFFSET IS MEASURED TO CENTERLINE OF STRUCTURE.
12. EXTEND PIPE 2" INTO MANHOLE. SEAL PIPE PENETRATIONS WITH NON-SHRINKABLE GROUT MIXED WITH POTABLE WATER PER MANUFACTURER'S RECOMMENDATIONS.
13. CATCH BASIN LEADS SHALL ENTER THE MANHOLE AT LEAST ONE PRIMARY LEAD DIAMETER ABOVE THE TOP OF THE PRIMARY LEAD UNLESS MINIMUM PIPE SLOPES CANNOT BE ACHIEVED.
14. MAXIMUM PIPE DIAMETER IS NOT TO EXCEED HALF OF THE STRUCTURE DIAMETER. PRIMARY LEADS MUST BE A MINIMUM OF 135 DEGREES APART.
15. LIVE LOAD FOR DESIGN OF THE MANHOLE BARRELS, RISERS, AND REDUCING SLABS IS AASHTO HL-93 (HS20 AND DESIGN TANDEM AXLE/WHEEL LOADS).
16. A FLAT LID WITH A SMALLER OPENING MAY ALSO BE USED IF CALLED FOR IN THE PLANS.

**REDUCING SLAB NOTES:**

1. USE NO. 5 FOR ALL REBAR EXCEPT STIRRUPS AND HOOPS.
2. SPACE ALL REBAR AT 6" CENTERS UNLESS OTHERWISE NOTED.
3. MAINTAIN A MINIMUM OF 1 1/2" OF CONCRETE COVER OVER ALL REBAR.
4. REINFORCING STEEL SHOWN IS A MINIMUM PER ASTM C478. PRECAST MFR TO COMPLETE AND SUBMIT SHOP DRAWINGS AND CALCULATIONS FOR ENGINEER'S REVIEW.

**MANHOLE STEP NOTES:**

1. MEET CURRENT OSHA STANDARDS FOR STEPS AND ACCESS OPENINGS.
2. PLACE STEPS 12" O.C. ON AN UNOBSTRUCTED SIDE OF THE STRUCTURE, 18" MAXIMUM FROM MANHOLE BASE. IF UNOBSTRUCTED SIDE NOT AVAILABLE, PLACE STEP 6" OVER SMALLEST PIPE. WHEN USING A CONE, FIRST LADDER RUNG IS 8" MAXIMUM FROM TOP OF CONE. WHEN USING A FLAT LID, FIRST LADDER RUNG IS 4" MAXIMUM FROM TOP OF RISER.
3. PROVIDE INJECTION MOLDED POLYPROPYLENE COVERED GRADE 60 STEEL STEPS TIGHTLY IMBEDDED AT LEAST 3" INTO CONCRETE.
4. INSTALL STEPS TO RESIST A PULLOUT FORCE OF 1500 LB.
5. THE MINIMUM DIAMETER OF CLEAR ACCESS TO STEP IS 24".
6. THE CONTRACTOR SHALL TAKE SPECIAL CARE FOR ANY MANHOLE THAT FALLS IN A CURB LINE TO SEE THAT WHEN MANHOLE IS OFFSET DURING INSTALLATION THAT THE STEPS FALL UNDER THE CURB INLET.

State of Alaska DOT&PF  
ALASKA STANDARD PLAN  
**72" STORM DRAIN MANHOLE (PRECAST CONCRETE)**  
**TYPE II MANHOLE**

Adopted as an Alaska Standard Plan by:   
Lauren Little, P.E.  
Interim Chief Engineer

Adoption Date: 01/29/2024

Last Code and Sids. Review By: BMM Date: 12/13/2023  
Next Code and Standards Review Date: 12/13/2033

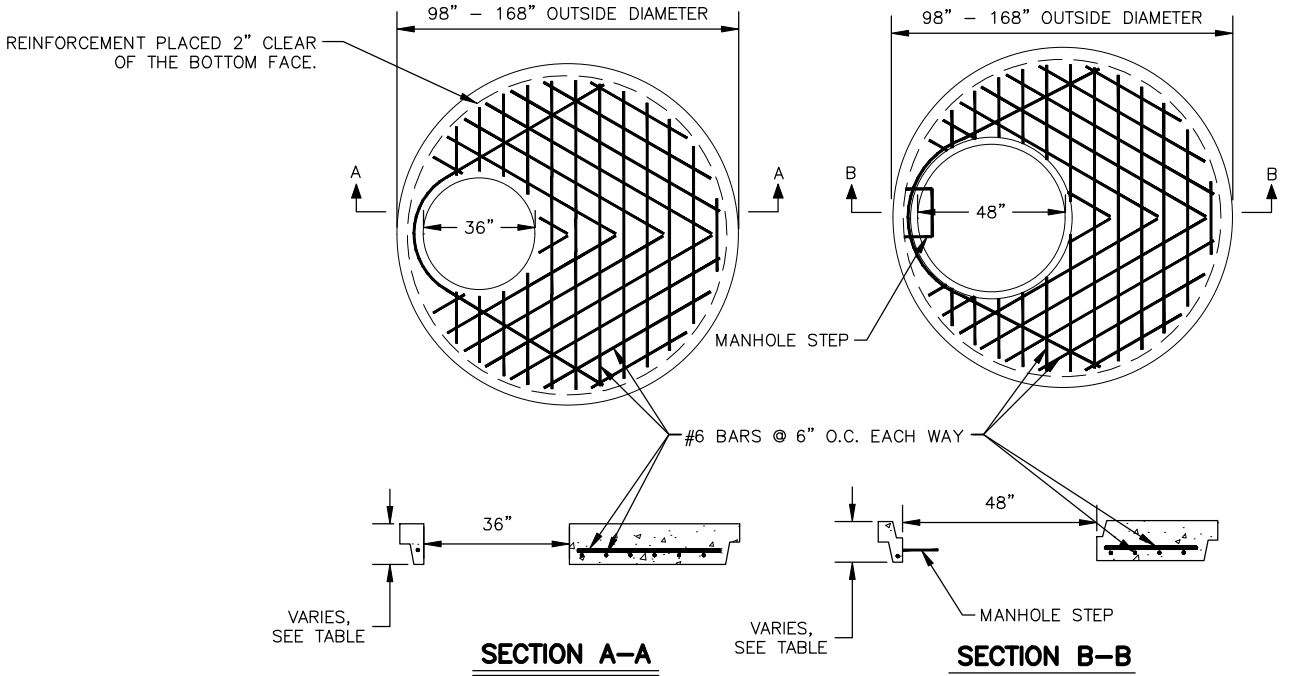
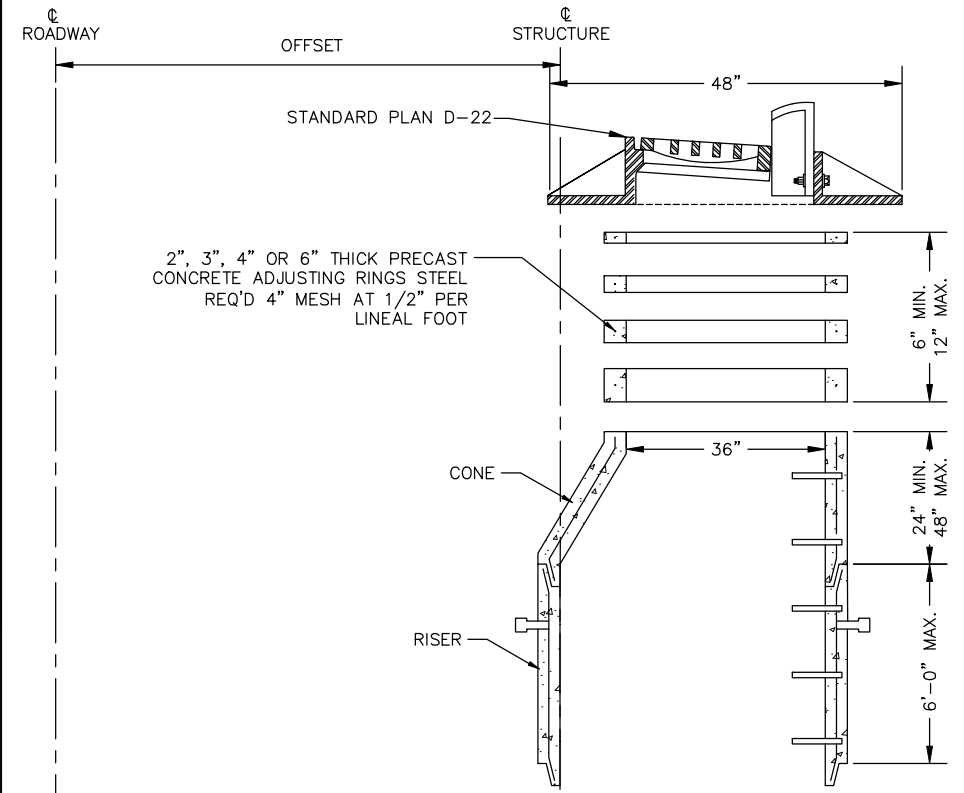

**PRECAST CONCRETE REDUCING SLAB (84"-144" TO 36")**  
N.T.S.

**PRECAST CONCRETE REDUCING SLAB (84"-144" TO 48")**  
N.T.S.

- MANHOLE STEP NOTES:**
1. MEET CURRENT OSHA STANDARDS FOR STEPS AND ACCESS OPENINGS.
  2. STEPS SHALL BE PLACED 12" O.C. ON AN UNOBSTRUCTED SIDE OF THE STRUCTURE, 18" MAXIMUM FROM MANHOLE BASE. IF UNOBSTRUCTED SIDE NOT AVAILABLE, BOTTOM STEP TO BE PLACED 6" OVER SMALLEST PIPE. WHEN USING A CONE, FIRST LADDER RUNG IS 8" MAXIMUM FROM TOP OF CONE. WHEN USING A FLAT LID, FIRST LADDER RUNG IS 4" MAXIMUM FROM TOP OF RISER.
  3. PROVIDE INJECTION MOLDED POLYPROPYLENE COVERED GRADE 60 STEEL STEPS TIGHTLY IMBEDDED AT LEAST 3" INTO CONCRETE.
  4. INSTALL STEPS TO RESIST A PULLOUT FORCE OF 1500 LB.
  5. THE MINIMUM DIAMETER OF CLEAR ACCESS TO STEP IS 24".
  6. THE CONTRACTOR SHALL TAKE SPECIAL CARE FOR ANY MANHOLE THAT FALLS IN A CURB LINE TO SEE THAT WHEN MANHOLE IS OFFSET DURING INSTALLATION THAT THE STEPS FALL UNDER THE CURB INLET.

STRUCTURE TABLE				
MANHOLE I.D.	MIN. WALL THICKNESS	MIN. BASE THICKNESS	MIN. TOP SLAB THICKNESS	MIN. BASE PAD DIAMETER
84"	7"	12"	12"	104"
96"	8"	12"	12"	118"
108"	9"	14"	14"	132"
120"	10"	16"	14"	140"
132"	11"	16"	14"	154"
144"	12"	16"	14"	168"

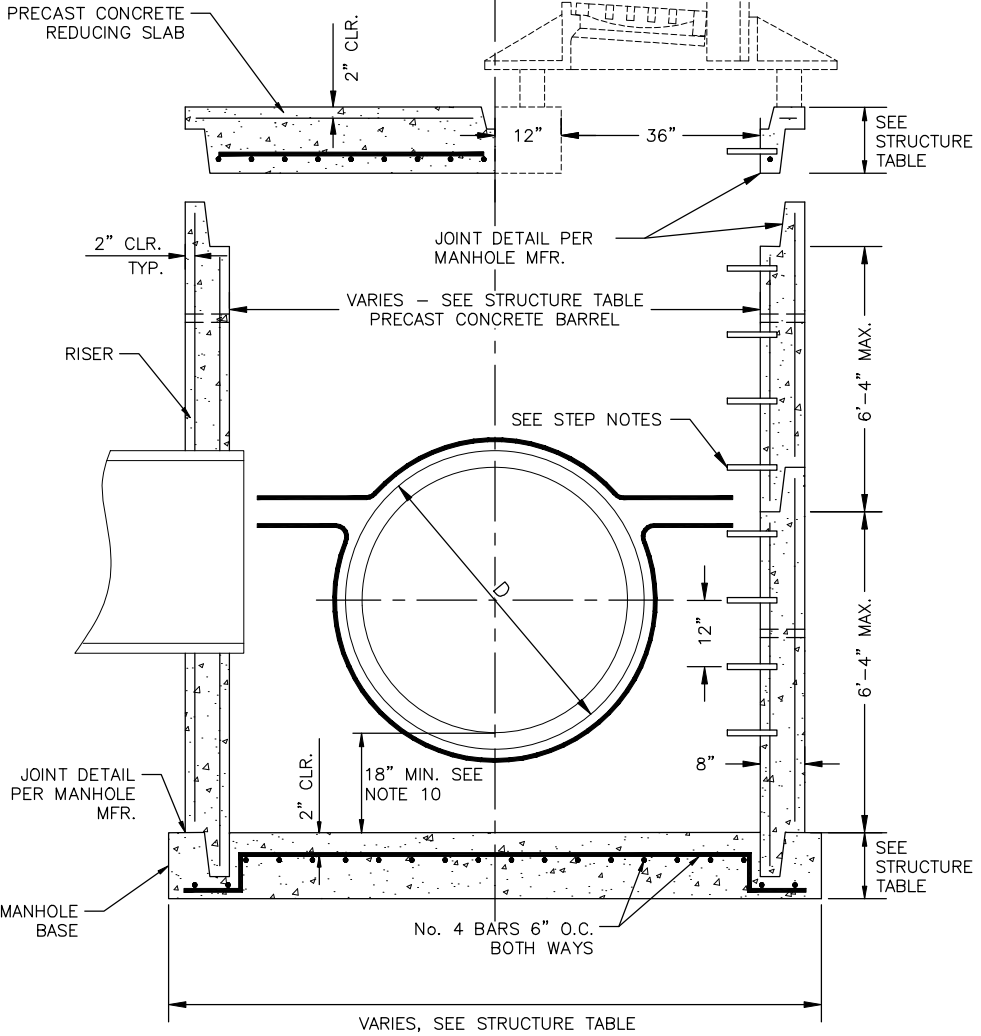

**STORM DRAIN MANHOLE, TYPE III**  
N.T.S.

- REDUCING SLAB NOTES:**
1. USE NO. 6 FOR ALL REBAR EXCEPT STIRRUPS AND HOOPS.
  2. ALL REBAR SHALL BE SPACED AT 6" CENTERS UNLESS OTHERWISE NOTED.
  3. MAINTAIN A MINIMUM OF 1 1/2" OF CONCRETE COVER OVER ALL REBAR.
  4. REINFORCING STEEL SHOWN IS A MINIMUM PER ASTM C478. PRECAST MFR TO COMPLETE AND SUBMIT SHOP DRAWINGS AND CALCULATIONS FOR ENGINEER'S REVIEW.

- GENERAL NOTES:**
1. THESE DRAWINGS ARE FOR PRECAST REINFORCED CONCRETE FOR HIGHWAY USE. CAST IN PLACE STRUCTURES MAY BE USED AS APPROVED BY THE ENGINEER.
  2. MEET THE REQUIREMENTS OF ASTM C-478 FOR ALL DRAINAGE STRUCTURES AND APPURTENANCES.
  3. WHEN BASE PAD IS ATTACHED TO FIRST BARREL SECTION, MINIMUM STEEL REQUIRED FOR BARREL AS PER ASTM C-478 SHALL BE IMBEDDED IN BASE SO THAT THE FIRST BARREL SECTION IS CONNECTED TO THE BASE BY CONTINUOUS STEEL. PROVIDE REINFORCING STEEL TYPE AND GRADE PER DOT&PF STANDARD SPECIFICATIONS.
  4. MINIMUM COVER ON REINFORCING STEEL IS 1" FOR CAST-IN-PLACE PRESTRESSED CONCRETE. ALL OTHER NON-PRESTRESSED CONCRETE TO HAVE 1 1/2" MIN. COVER.
  5. USE CLASS A OR CLASS B CONCRETE PER DOT&PF STANDARD SPECIFICATIONS.
  6. SEAL RISER JOINTS WITH FLEXIBLE PLASTIC JOINT SEALERS.
  7. PROVIDE NON-SHRINK GROUT. PROTECT GROUT DURING CURE IN ACCORDANCE WITH THE MANUFACTURER'S RECOMMENDED METHOD.
  8. FORM ALL BLOCK-OUTS.
  9. MANHOLE SHALL HAVE A MINIMUM OF ONE 6" GRADE RING.
  10. ALL STORM DRAIN MANHOLES AND INLETS SHALL HAVE 18" MINIMUM SUMPS. MANHOLES WITH PETROLEUM SEPARATORS SHALL HAVE 24" MINIMUM SUMPS.
  11. OFFSET IS MEASURED TO CENTERLINE OF STRUCTURE.
  12. EXTEND PIPE 2" INTO MANHOLE. SEAL PIPE PENETRATIONS WITH NON-SHRINKABLE GROUT MIXED WITH POTABLE WATER PER MANUFACTURES RECOMMENDATIONS.
  13. CATCH BASIN LEADS SHALL ENTER THE MANHOLE AT LEAST ONE PRIMARY LEAD DIAMETER ABOVE THE TOP OF THE PRIMARY LEAD UNLESS MINIMUM PIPE SLOPES CANNOT BE ACHIEVED.
  14. MAXIMUM PIPE DIAMETER IS NOT TO EXCEED HALF OF THE STRUCTURE DIAMETER. PRIMARY LEADS MUST BE A MINIMUM OF 135 DEGREES APART.
  15. ALL PENETRATIONS REQUIRE ADDITIONAL #4 HOOP.
  16. LIVE LOAD FOR DESIGN OF THE MANHOLE BARRELS, RISERS AND REDUCING SLABS IS AASHTO HL-93 (HS20 AND DESIGN TANDEM AXLE/WHEEL LOADS).
  17. A FLAT LID WITH A SMALLER OPENING MAY ALSO BE USED IF CALLED FOR IN THE PLANS.

State of Alaska DOT&PF  
ALASKA STANDARD PLAN  
84" TO 144" STORM DRAIN  
MANHOLE  
(PRECAST CONCRETE)  
TYPE III MANHOLE

Adopted as an Alaska  
Standard Plan by:

Lauren Little, P.E.  
Interim Chief Engineer

Adoption Date: 01/29/2024

Last Code and Sids. Review  
By: BMM Date: 12/13/2023

Next Code and Standards Review Date: 12/13/2033

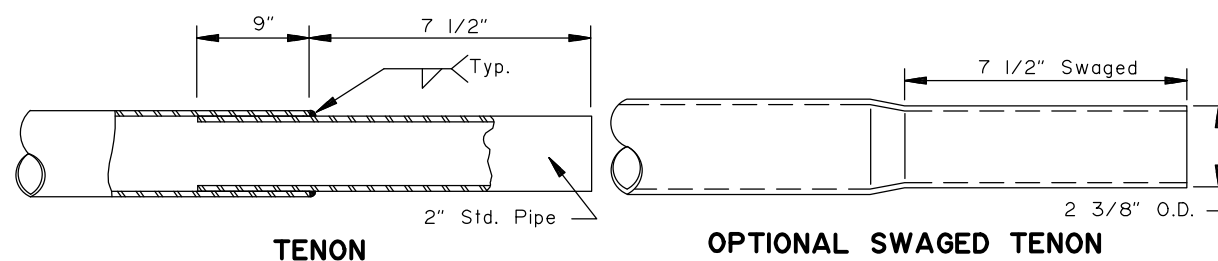
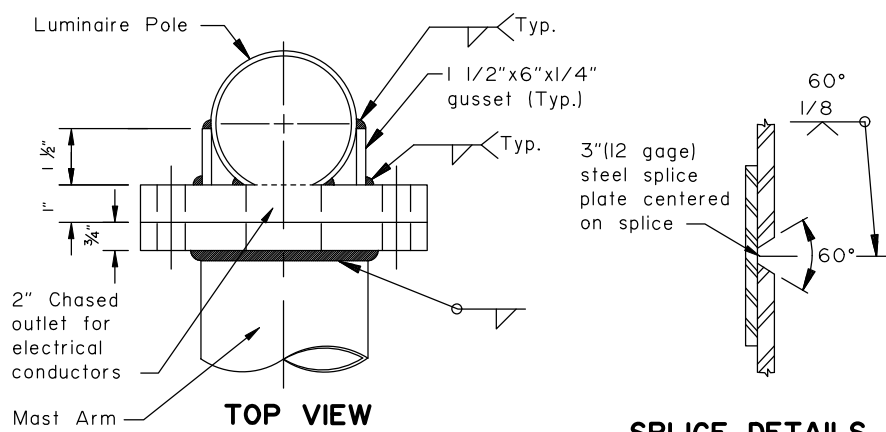

**END OF MAST ARM DETAIL**

**GENERAL NOTES:**

- Design and fabricate Lighting Standards according to AASHTO LTS-6-13, 2019 and 2020 Interim Revisions to (2013 Sixth Edition) Standard Specifications for Structural Supports for Highway Signs, Luminaires, and Traffic Signals. Fatigue and temporary loads are not to be considered.

All shafts shall support the maximum arm lengths shown in the MAST ARM DATA table with luminaire. Assume each offset fixture weighs 30 lbs. and has an effective projected area of 1.5 SF. Assume each Cobra weighs 25 lbs. and has an effective projected area of 0.75 square feet. The electrolier total weight shall not exceed 992 lbs.

- Weld size to be determined by manufacturer.
- Mounting height, if specified in the plans, refers to the height of luminaire above the finished roadway surface. Adjust each pole's shaft length to maintain this difference in elevation whenever slope and/or offset varies.
- Minimum outside diameter at the top of pole equals 3-7/8". Pole diameter shall taper uniformly from the top of pole to the base plate, with a minimum taper rate of 0.14" per foot.
- Mast arm rise may vary ±0.5ft from the values listed in the table.
- Locate the handhole at 90 degrees to the mast arm on the side of pole downstream from traffic flow.
- Furnish all poles with a j-hook to support the illumination tap conductors. Furnish all mast arm poles with a removable raintight cap.
- See ASP L-30 for frangible coupling and skirt details and notes.

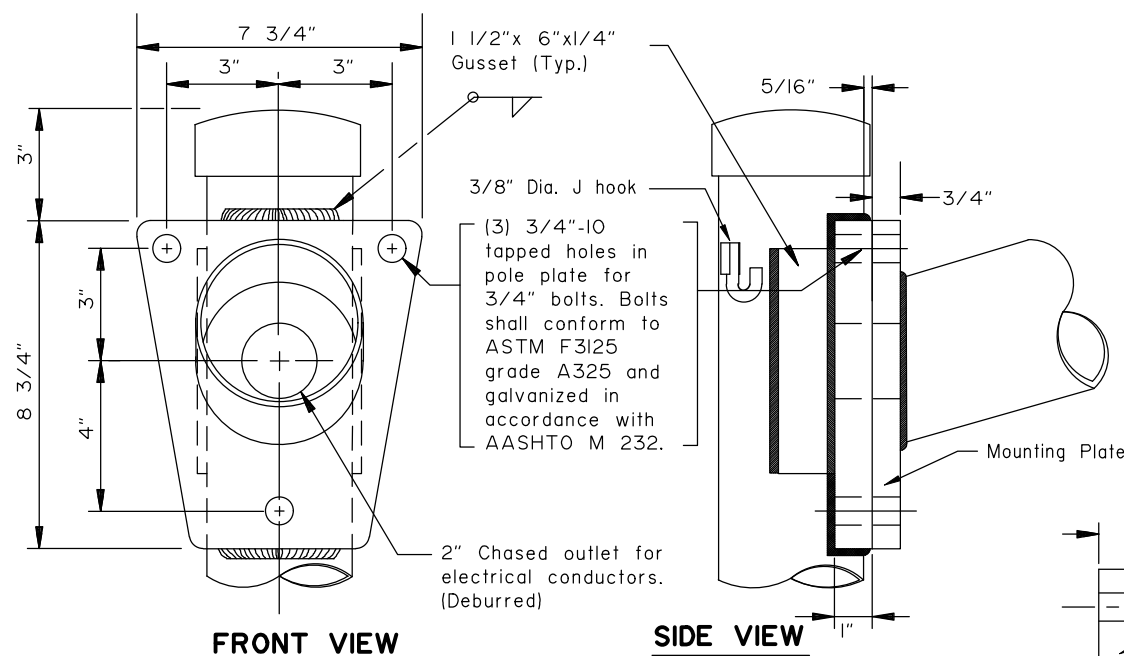

**MAST ARM CONNECTION DETAIL**

MAST ARM DATA		
ARM LENGTH	ARM RISE	SHAFT LENGTH (MAX)
22'-4"	6'-0"	40'
20'-4"	5'-6"	42'
18'-4"	4'-6"	44'
15'-4"	4'-3"	46'
12'-4"	3'-6"	49'
10'-4"	2'-6"	51'
8'-4"	2'-3"	53'
6'-4"	1'-6"	55'
4'-4"	1'-3"	55'
TENON MOUNT		55'

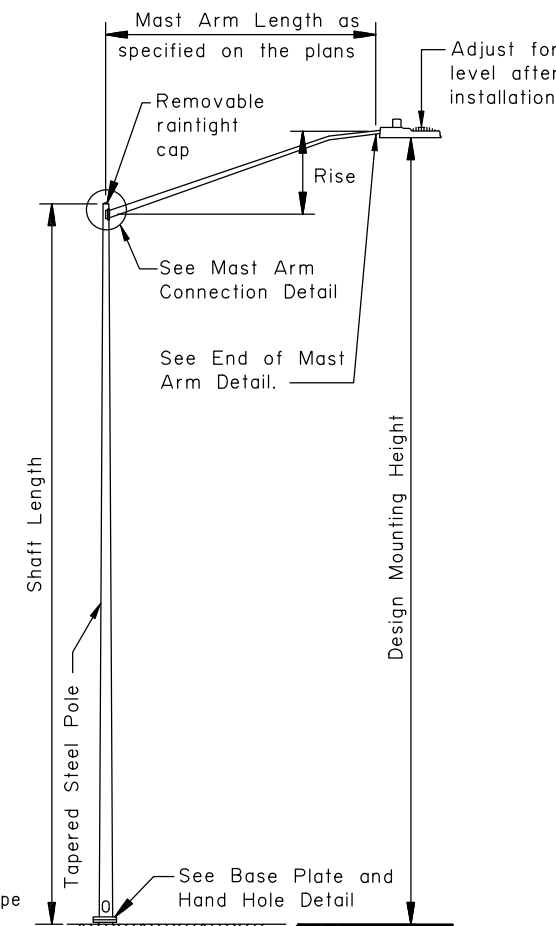

**ELECTROLIER ELEVATION  
COBRA HEAD**

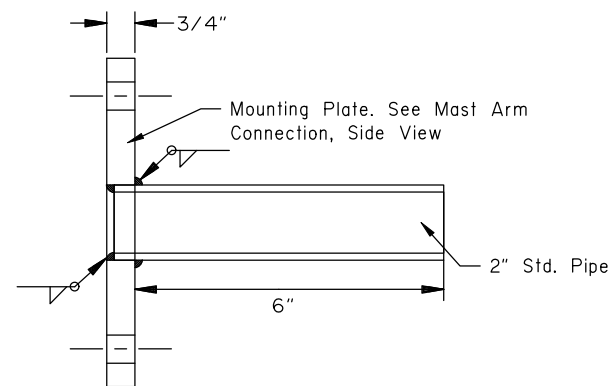

**TENON MOUNT DETAIL**

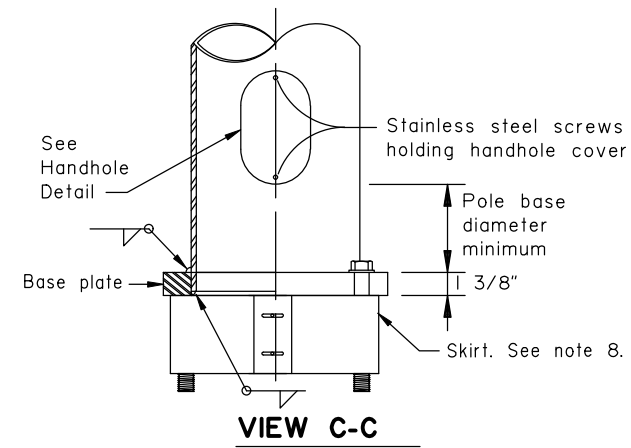
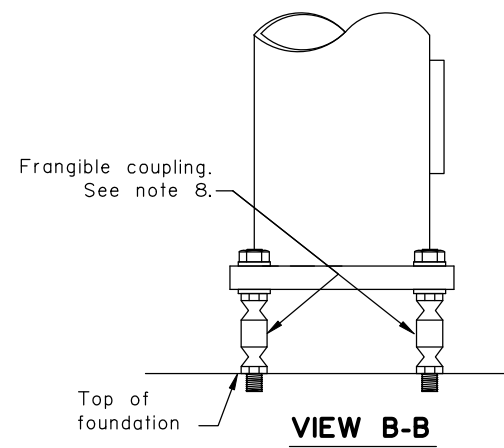
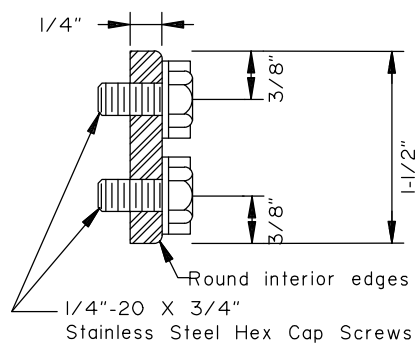
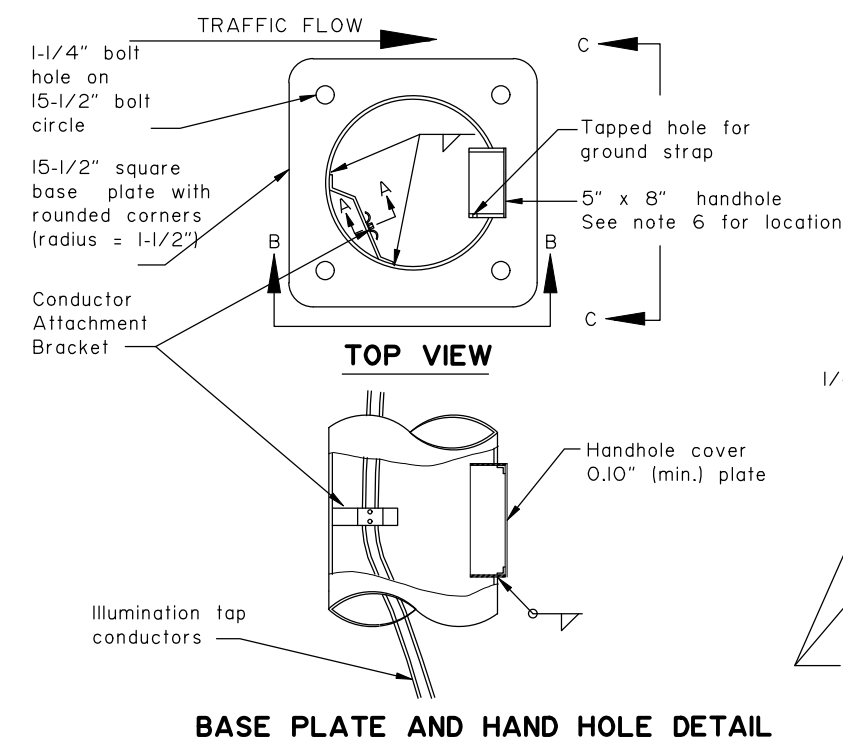

State of Alaska DOT&PF  
ALASKA STANDARD PLAN  
LIGHTING STANDARDS

Adopted as an Alaska Standard Plan by:

Lauren Little, P.E.  
Interim Chief Engineer

Adoption Date: 01/29/2024

Last Code and Stds. Review  
By: CMW Date: 12/19/2023

Next Code and Standards Review Date: 12/19/2033

MATERIAL REQUIREMENTS		
Concrete	Class A	$f'_c = 4000$ PSI
CMP	AASHTO M218	14 GA.
VERTICAL REINFORCING STEEL	AASHTO M31 #8	GR 60
SPIRAL REINFORCING STEEL	AASHTO M31 #5	GR 60
GROUND WIRE		#4 AWG
Frangible Coupling and Anchor	NCHRP 350 TL3 (See note 10)	$V_u = 5.5$ KIPS
Conduit	Sch 40	RMC
Protective Sleeve	Sch 40	PVC

DEPTH TABLE (See design notes for loads)	
GRADE	FOUNDATION DEPTH (ft.)
FLAT TO 6:1	8
>=6:1 TO 3:1	9
>=3:1 TO 1.5:1	10.5

CONTROLLED LOW STRENGTH MATERIAL MIX DESIGN		
ITEM	BATCHING QUANTITIES PER CYD BATCH (LBS.)	APPLICABLE SPECS.
PORTLAND CEMENT CONCRETE	188	701-2.01
Water (52.1 Gal.)	435	712-2.01
Fine Aggregate SSD	3041	703-2.01
Admixture: Air entrainment	2.0 OZ.	711-2.02
<b>Total</b>	<b>3664</b>	

### DESIGN NOTES:

Design Standard: 2013 Standard Specifications for Structural Supports for Highway Signs, Luminaires and Traffic Signals with 2019 and 2020 Interim Revisions (SSSS).

Maximum Unfactored Service Loads (SSSS): 1,500 lbs axial, 1,500 lbs shear, 35,000 ft-lbs moment.

Wind and Soil: Foundations shall not be used for locations over 100 mph basic wind speed as shown in the SSSS figure 3.8.3-1. This foundation is approved for electrolier and breakaway traffic signal applications in cohesionless soils with an NI-60 value of 20 or greater (SPT) and a minimum soil density = 120pcf and friction angle of 32.5 degrees per AASHTO T-206, "Standard Penetration Test" (SPT).

### NOTES:

- This foundation shall not be used if any of the following are encountered; water table above the bottom of foundation, very loose soils, organic soils, cohesive soils (clay), or soils susceptible to frost jacking. If any of these conditions are encountered, stop foundation work and contact the Engineer.
- Place foundation in drilled or excavated hole with centerline of foundation located at the station, offset, and elevation specified in plans. Set foundation to satisfy the conditions depicted in clearance detail.
- Form the foundation in corrugated metal pipe conforming to Subsection 707-2.01 of the Specifications.
- Provide 1.5 extra turns at each end of the spiral reinforcing steel. Reinforcing steel shall not be spliced. Tie vertical reinforcing steel to each intersection of the spiral reinforcing steel.
- Connect ground wire near the top of spiral reinforcing steel with two irreversible connectors as shown. Fasten connectors according to the manufacturers' recommendations including the use of manufacturer specified tools. The ground wire may be bare solid, stranded, or braided copper. Protect ground wire with protective sleeve as shown and fill with silicon sealant.
- Backfill and compact according to Section 205, and Subsections 203-3.04 and 660-3.01 of the Specifications. Use selected material, Type A or controlled low strength material as backfill material. Ensure area below foundation meets compaction requirements and is free of loose material and debris prior to concrete work.
- Install all anchors according to the manufacturer's written installation instructions. Anchors shall be installed plumb. Anchors greater than 1:40 out-of-plumb will result in foundation rejection.
- Grade in depth table refers to fill slopes. If foundation is in a cut slope assume flat grade in table. To determine grade in fill slopes, use the most severe grade found within an 8 foot radius of the center of the foundation.
- If provided couplings have greater design values than  $V_u=5.5$  kips per each coupling (22,000 lbs total), submit stamped engineering calculations, related drawings, and other necessary information as required to verify the adequacy of the foundation design for increased loads.
- Frangible couplings shall be NCHRP 350, Test Level 3 compliant and installed in accordance with the manufacturers written instructions.
- Frangible couplings shall be installed into flush mounted female anchors so that no fixed hardware extends above the foundation top.
- Install all components of the breakaway support system in accordance with the manufacturer's written instructions.
- Fabricate the skirt as shown in detail. Bend each plate to provide corners with a 3/4" radius. The assembled skirt measures about 12-7/8" square.

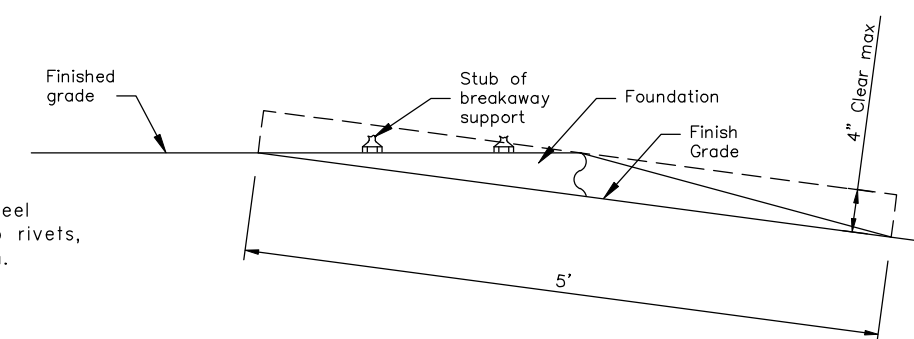
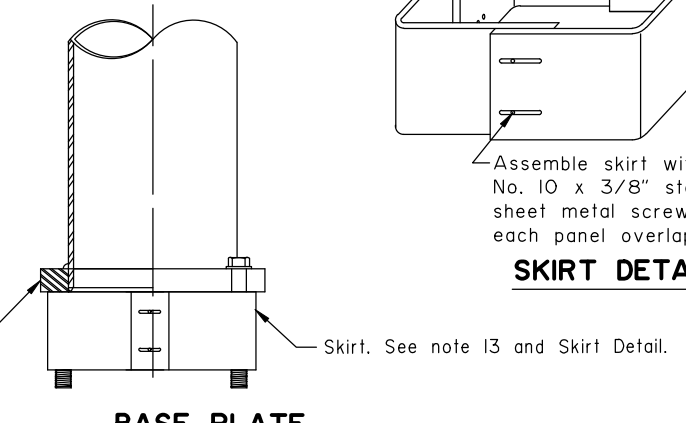
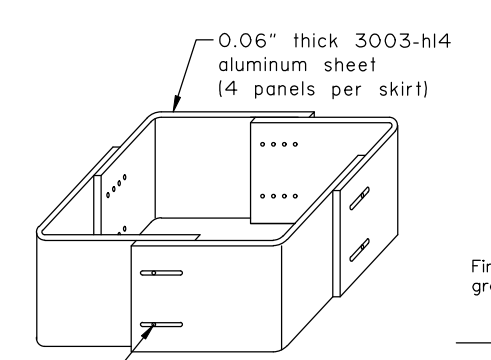
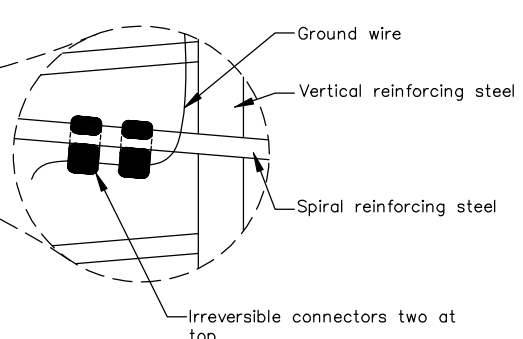
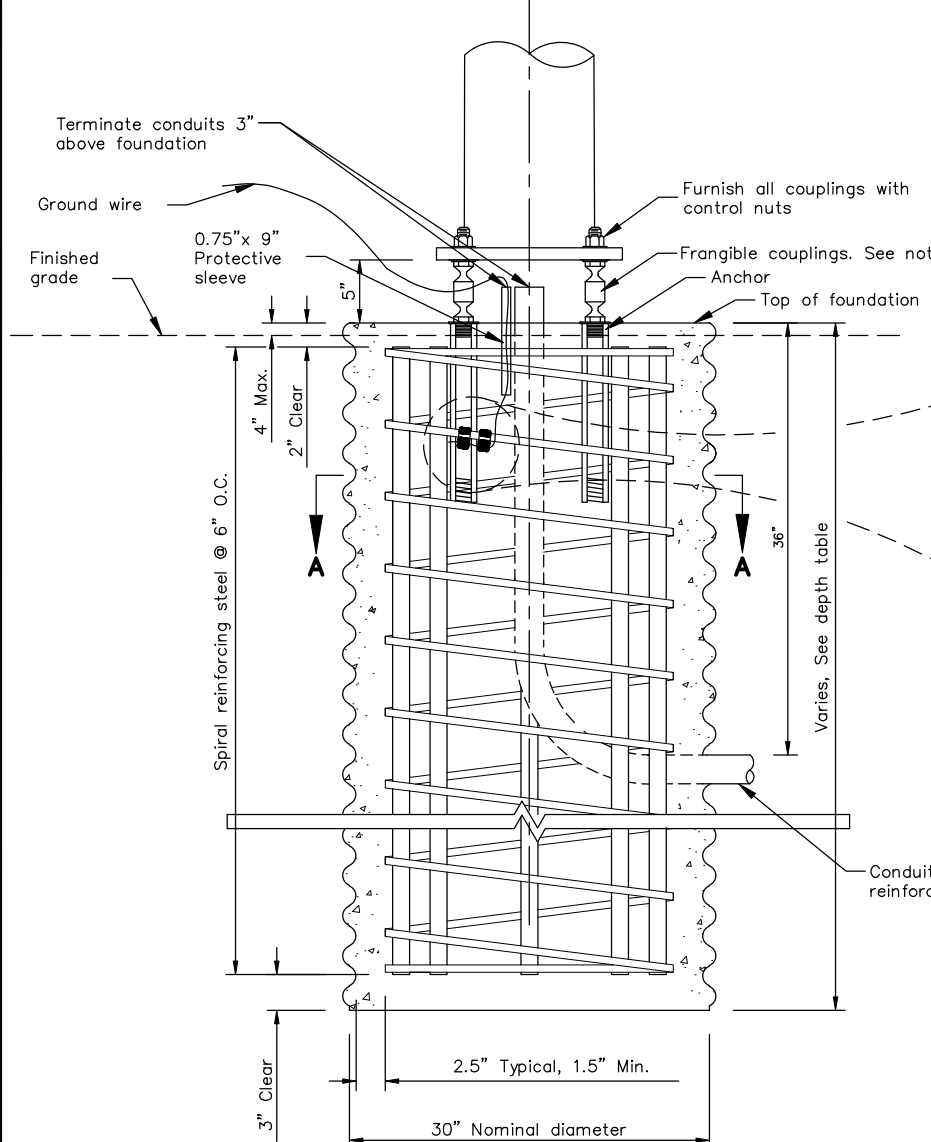
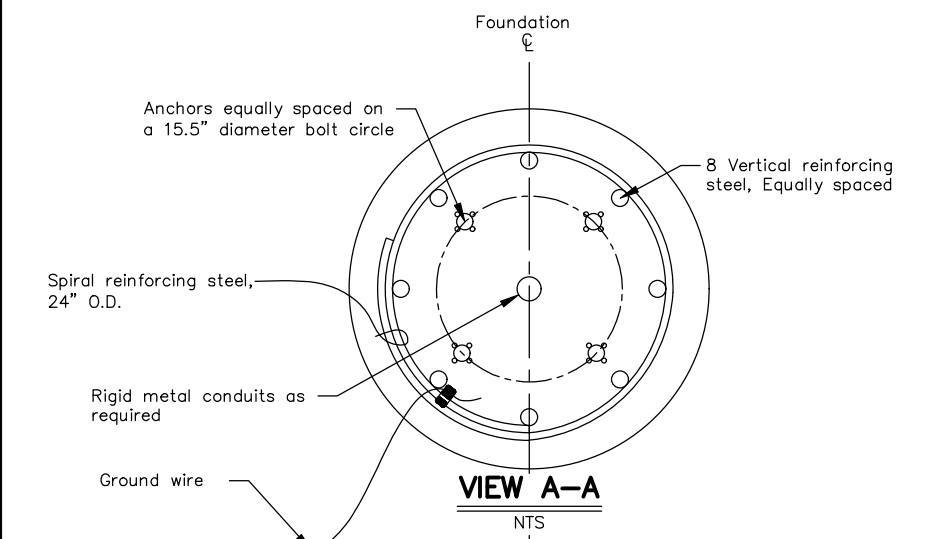

State of Alaska DOT&PF  
ALASKA STANDARD PLAN  
**CONCRETE STREET LIGHT POLE FOUNDATION**

Adopted as an Alaska Standard Plan by:   
Lauren Little, P.E.  
Interim Chief Engineer

Adoption Date: 01/29/2024

---

Last Code and Stds. Review  
By: AH Date: 12/13/2023

Next Code and Standards Review Date: 12/13/2033

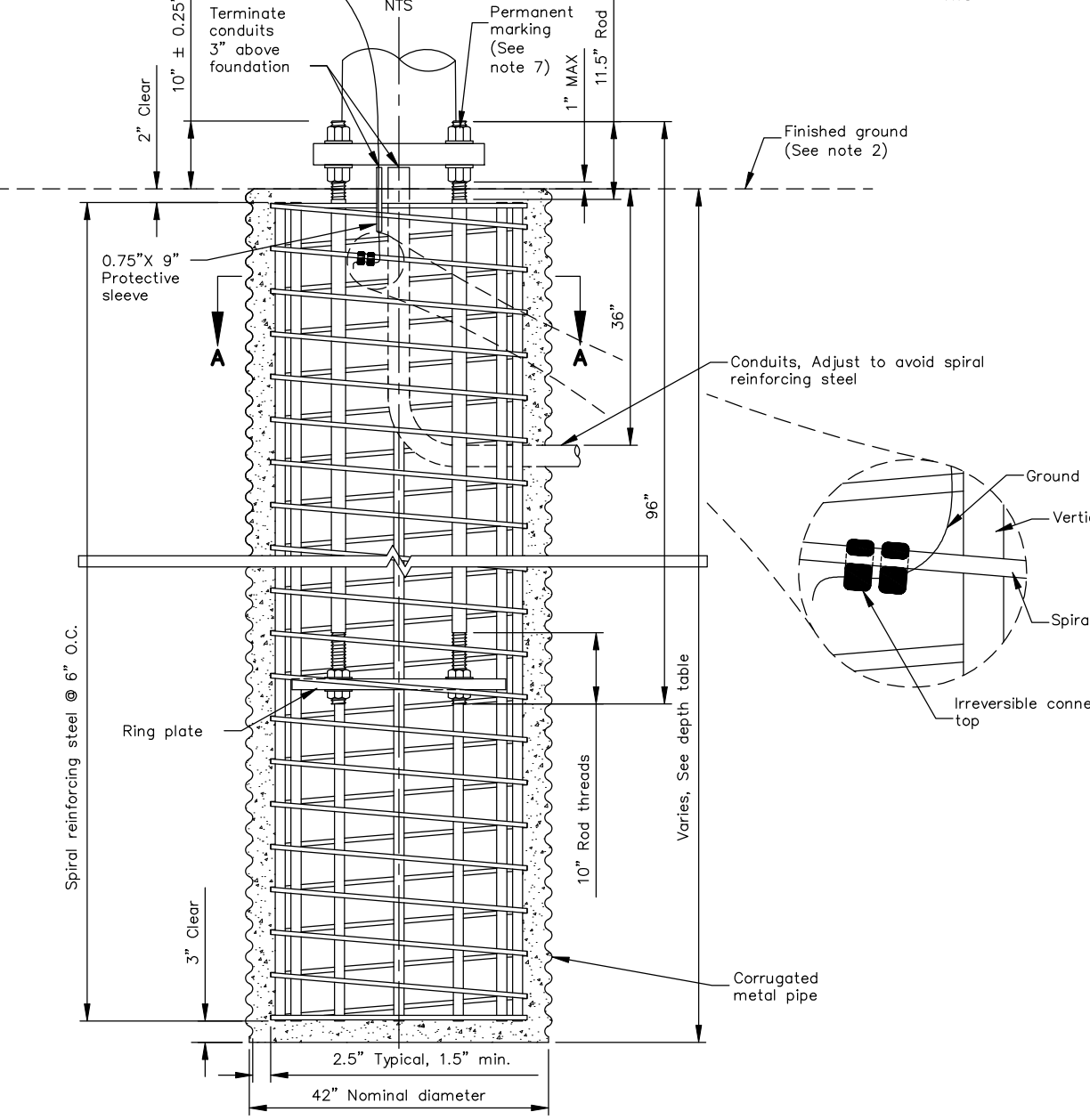
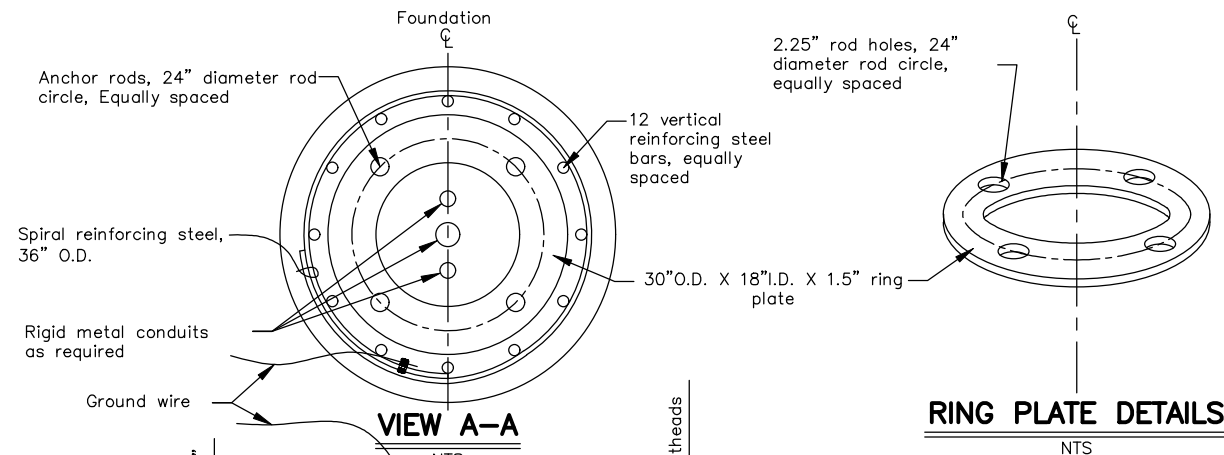

**FOUNDATION DETAILS**  
Skirt omitted for clarity

MATERIAL REQUIREMENTS		
Concrete	Class A	$f'_c = 4000$ psi
CMP	AASHTO M218	14 ga.
Vertical reinforcing steel	AASHTO M31 #9	GR 60
Spiral reinforcing steel	AASHTO M31 #5	GR 60
Ground wire		#4 awg
Anchor rods 2" X 96"	ASTM F1554 S2, S3, & S5	GR 105
Fasteners, washers	ASTM F436	
Fasteners, nuts	AASHTO M292M	
Finish, anchor rods & fasteners	AASHTO M232	
Ring plate	AASHTO M270	GR 36
Conduit	Sch 40	RMC
Protective sleeve	Sch 40	PVC

DEPTH TABLE (See design notes for loads)	
Mastarm length (ft.)	Foundation depth (ft.)
	Single mastarm
$L \leq 40$	10
$40 < L \leq 50$	11
$50 < L \leq 65$	12

CONTROLLED LOW DENSITY MATERIAL MIX DESIGN		
Item	Batching quantities per cy batch (lbs.)	Applicable specs.
Portland Cement	188	701-2.01
Water (52.1 gal.)	435	712-2.01
Fine Aggregate SSD	3041	703-2.01
Admixture Entrainment	Air 2.0 oz.	711-2.02
Total	3664	

**DESIGN NOTES:**

Design Standard: 2013 Standard Specifications for Structural Supports for Highway Signs, Luminaires and Traffic Signals with 2013 Errata 2019 and 2020 Interim Revisions (SSSS).

Maximum Unfactored Service Loads (SSSS):

Axial	Shear	Moment	Torsion	Length
6,500 LBS	5,200 LBS	117,200 FT-LBS	68,800 FT-LBS	$L \leq 40$
7,000 LBS	5,300 LBS	131,200 FT-LBS	98,700 FT-LBS	$40 < L \leq 50$
9,000 LBS	6,400 LBS	215,100 FT-LBS	162,500 FT-LBS	$50 < L \leq 65$

Wind: Foundations shall not be used for locations over 100 mph basic wind speed as shown in the 2013 SSSS figure 3.8.3-1.

Soil: This foundation is approved for traffic signal applications in cohesionless soils with an N1-60 value of 20 or greater per AASHTO T-206, "Standard Penetration Test" (SPT) and soil density = 120 pcf and friction angle of 32.5 degrees.

**NOTES:**

- This foundation shall not be used if any of the following are encountered: water table above the bottom of foundation, very loose soils, organic soils, cohesive soils (clay), slopes steeper than 6:1, or soils susceptible to frost jacking. If any of these conditions are encountered, stop foundation work and contact the engineer.
- Place foundation in drilled or excavated hole with centerline of foundation located at the station, offset, and elevation specified in plans. Set foundation flush with surrounding surface. Grade to drain away from foundation without exposing more than 4" of the foundation from the surrounding ground surface.
- Form the foundation in corrugated metal pipe conforming to Subsection 707-2.01 of the Specifications.
- Provide 1.5 extra turns at each end of the spiral reinforcing steel. Reinforcing steel shall not be spliced. Tie vertical reinforcing steel to each intersection of the spiral reinforcing steel.
- Connect ground wire near the top spiral reinforcing steel with two irreversible connectors as shown. Fasten connectors according to the manufacturers' recommendations including the use of manufacturer specified tools. The ground wire may be bare solid, stranded, or braided copper. Protect ground wire with protective sleeve as shown and fill with silicon sealant.
- The ring plate may be "built up" of multiple steel plates. The minimum thickness for any one plate is 0.5 inches. Fasten the ring plate to anchor rods with nuts and washers on both sides of ring plate as shown. Torque ring plate nuts to 600 ft-lbs.
- Anchor rods are subject to Charpy V-Notch Impact Testing. Submit mill certifications for anchor rods, nuts and washers. Galvanize anchor rods full length. Provide permanent manufacturer's identification and permanent grade identification on each end of anchor rod by steel die stamp. Secure exposed anchor rods with a "ring plate" when not in service. Install anchor rods plumb. Anchor rods greater than 1:40 out-of-plumb will result in foundation rejection.
- Dual mast arms are not included in this standard and shall have custom designs.
- Backfill and compact according to Section 204, and Subsections 203-3.04 and 660-3.01 of the Specifications. Use select material, Type A or controlled low density material as backfill material. Ensure area below foundation meets compaction requirements and is free of loose material and debris prior to concrete work.

State of Alaska DOT&PF  
ALASKA STANDARD PLAN  
CONCRETE 42" DIAMETER  
SIGNAL POLE FOUNDATION

Adopted as an Alaska  
Standard Plan by:   
Lauren Little, P.E.  
Interim Chief Engineer

Adoption Date: 01/29/2024

Last Code and Sids. Review  
By: AH Date: 12/13/2023  
Next Code and Standards Review Date: 12/13/2033

T-52.23

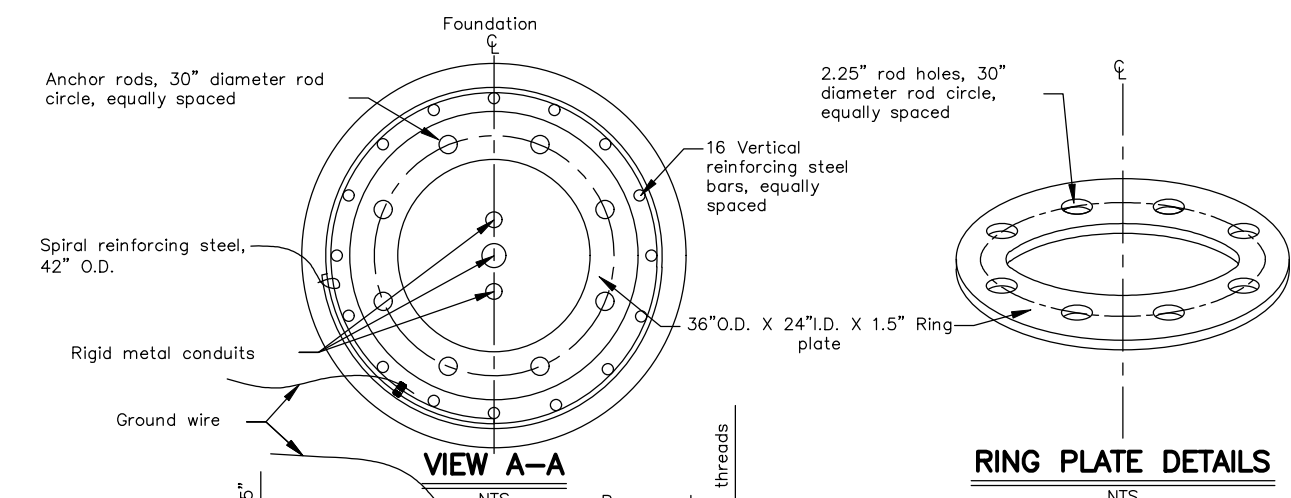

MATERIAL REQUIREMENTS		
Concrete	Class A	$f'_c = 4000$ psi
Cmp	AASHTO M218	14 ga.
Vertical reinforcing steel	AASHTO M31 #9	GR 60
Spiral reinforcing steel	AASHTO M31 #5	GR 60
Ground wire		#4 awg
Anchor rods 2" X 96"	ASTM F1554 S2, S3, & S5	GR 105
Fasteners, washers	ASTM F436	
Fasteners, nuts	AASHTO M292M	
Finish, anchor rods & fasteners	AHTO M232	
Ring plate	AASHTO M270	GR 36
Conduit	Sch 40	RMC
Protective sleeve	Sch 40	PVC

DEPTH TABLE (See Design Notes for Loads)	
Mastarm length (ft.)	Foundation depth (ft.)
	Single mastarm
65 < L ≤ 75	12

CONTROLLED LOW DENSITY MATERIAL MIX DESIGN		
Item	Batching quantities per cy batch (lbs.)	Applicable specs.
Portland cement	188	701-2.01
Water (52.1 gal.)	435	712-2.01
Fine aggregate ssd	3041	703-2.01
Admixture	Air	2.0 OZ.
Entrainment		711-2.02
Total	3664	

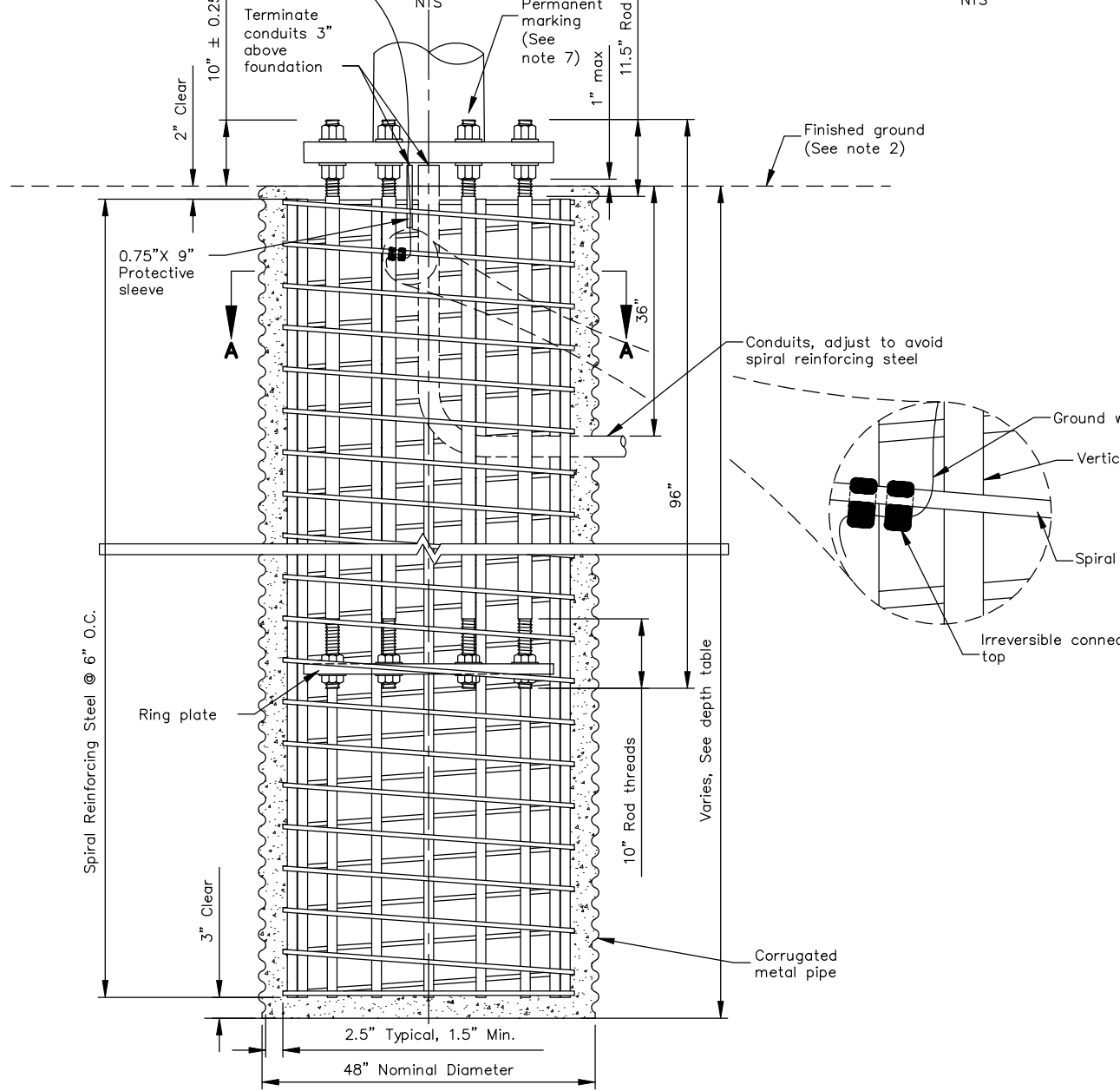

**DESIGN NOTES:**

- Design Standard: 2013 Standard Specifications for Structural Supports for Highway Signs, Luminaires and Traffic Signals with 2013 Errata and 2019 and 2020 Interim Revisions (SSSS).
- Maximum Unfactored Service Loads (SSSS): 11,000 lbs axial, 7,100 lbs shear, 268,400 ft-lbs moment, 197,600 ft-lb torsion.
- Wind: This standard shall not be used for locations over 100 mph basic wind speed as shown in the 2013 SSSS, figure 3.8.3-1
- Soil: This foundation is approved for traffic signal applications in cohesionless soils with an N1-60 value of 20 or greater per AASHTO T-206, "Standard Penetration Test" (SPT) and soil density = 120 pcf and friction angle of 32.5 degrees.

**NOTES:**

- This foundation shall not be used if any of the following are encountered: water table above the bottom of foundation, very loose soils, organic soils, cohesive soils (clay), slopes steeper than 6:1, or soils susceptible to frost jacking. If any of these conditions are encountered, stop foundation work and contact the engineer.
- Place foundation in drilled or excavated hole with centerline of foundation located at the station, offset, and elevation specified in plans. Set foundation flush with surrounding surface. Grade to drain away from foundation without exposing more than 4" of the foundation from the surrounding ground surface.
- Form the foundation in corrugated metal pipe conforming to Subsection 707-2.01 of the Specifications.
- Provide 1.5 extra turns at each end of the spiral reinforcing steel. Reinforcing steel shall not be spliced. Tie vertical reinforcing steel to each intersection of the spiral reinforcing steel.
- Connect ground wire near the top spiral reinforcing steel with two irreversible connectors as shown. Fasten connectors according to the manufacturers' recommendations including the use of manufacturer specified tools. The ground wire may be bare solid, stranded, or braided copper. Protect ground wire with protective sleeve as shown and fill with silicon sealant.
- The ring plate may be "built up" of multiple steel plates. The minimum thickness for any one plate is 0.5 inches. Fasten the ring plate to anchor rods with nuts and washers on both sides of ring plate as shown. Torque ring plate nuts to 600 ft-lbs.
- Anchor rods are subject to Charpy V-Notch Impact Testing. Submit mill certifications for anchor rods, nuts and washers. Galvanize anchor rods full length. Provide permanent manufacturer's identification and permanent grade identification on each end of anchor rod by steel die stamp. Secure exposed anchor rods with a "ring plate" when not in service. Install anchor rods plumb. Anchor rods greater than 1:40 out-of-plumb will result in foundation rejection.
- Dual mast arms are not included in this standard and shall have custom designs.
- Backfill and compact according to Section 204, and Subsections 203-3.04 and 660-3.01 of the Specifications. Use select material, Type A or controlled low density material as backfill material. Ensure area below foundation meets compaction requirements and is free of loose material and debris prior to concrete work.

State of Alaska DOT&PF  
ALASKA STANDARD PLAN  
CONCRETE 48" DIAMETER  
SIGNAL POLE FOUNDATION

Adopted as an Alaska Standard Plan by:   
Lauren Little, P.E.  
Interim Chief Engineer

Adoption Date: 01/29/2024

Last Code and Sds. Review  
By: AH Date: 12/13/2023  
Next Code and Standards Review Date: 12/13/2033