

NOAA Data Report ERL GLERL-30



MEASUREMENTS OF ICE MOTION IN LAKE ERIE
USING SATELLITE-TRACKED DRIFTER BUOYS

Joan E. Campbell
Anne H. Clites
Gordon M. Greene

Great Lakes Environmental Research Laboratory
Ann Arbor, Michigan
March 1987

noaa

NATIONAL OCEANIC AND
ATMOSPHERIC ADMINISTRATION

Environmental Research
Laboratories

NOAA Data Report ERL GLERL-30

MEASUREMENTS OF ICE MOTION IN LAKE ERIE
USING SATELLITE-TRACKED DRIFTER BUOYS

Joan E. Campbell
Anne H. Clites
Gordon M. Greene

Great Lakes Environmental Research Laboratory
Ann Arbor, Michigan
March 1987



**UNITED STATES
DEPARTMENT OF COMMERCE**

**Malcolm Baldrige,
Secretary**

**NATIONAL OCEANIC AND
ATMOSPHERIC ADMINISTRATION**

**Anthony J. Calio,
Administrator**

**Environmental Research
Laboratories**

**Vernon E. Derr,
Director**

NOTICE

Mention of a commercial company or product does not constitute an endorsement by NOAA/ERL. Use for publicity or advertising purposes, of information from this publication concerning proprietary products or the tests of such products, is not authorized.

For sale by the National Technical Information Service, 5285 Port Royal Road
Springfield, VA 22161

CONTENTS

	PAGE
ABSTRACT.....	1
1. INTRODUCTION.....	1
2. METHODS.....	1
3. RESULTS.....	3
4. DISCUSSION.....	5
5. SUMMARY.....	6
6. References.....	7
Appendix A: The observed and interpolated Lake Erie 1984 ice conditions..	9
Appendix B: Buoy and wind velocities.....	17

FIGURES

Figure 1.--The Argos-transmitting buoy with orange flagging.....	2
Figure 2.--The Lake Erie study site.....	3
Figure 3.--The unedited (a) and edited (b) tracks of buoy movement.....	4
Figure 4.--A histogram of buoy speeds.....	5

TABLES

Table 1.--Buoy histories.....	3
-------------------------------	---

MEASUREMENTS OF ICE MOTION
IN LAKE ERIE USING SATELLITE-TRACKED DRIFTER BUOYS*

Joan E. Campbell, Anne H. Clites, and Gordon M. Greene

ABSTRACT. Four Argos tracked drifting buoys were used to measure ice movement on Lake Erie during the winter of 1984. The observed ice drift speeds averaged 8 cm s^{-1} . Speeds as high as 46 cm s^{-1} were measured and 6.5% of all speeds were greater than 20 cm s^{-1} . A comprehensive data set including ice reconnaissance, aerial photographs, and ice thickness measurements was obtained.

1. INTRODUCTION

Both natural processes and human activities are affected by ice movement on Lake Erie. Large-scale ice motion, for example, causes ridging and scouring, destroys offshore structures, and creates hazards to navigation. The extent of the ice cover determines routes for through-lake navigation and the time when the Niagara River ice boom will be removed. The prolonged ice cover near Buffalo, N.Y., due to the Niagara River ice boom, and its potential effect on the local climate are controversial topics (Quinn et al., 1982; Rumer, 1980; Quinn et al., 1980; Rumer et al., 1975; Rumer and Acres, 1974).

Little quantitative information currently exists on ice movement in the lake. Numerical models of ice dynamics in Lake Erie have been developed (Rumer and Yu, 1978; Wake and Rumer, 1979; 1983; Rumer, 1973; Rumer et al., 1981) but have been limited by the lack of an adequate data set for calibration and verification. Although satellite and aircraft imagery have been used to measure ice movement, their resolution is too coarse for thoroughly testing a numerical model (McNutt, 1981). This report describes an experiment designed to measure ice transport rates across the central and eastern basins of Lake Erie in sufficient detail to verify numerical models of ice movement. A secondary goal of the experiment was to test the feasibility of using satellite-tracked drifter buoys to obtain ice movement data.

2. METHODS

Polar Research Laboratory's satellite-tracked Mini-TOD buoys were used to measure ice transport rates. The buoy hulls are constructed of aluminum and fiberglass, and weigh 33 kg. The buoys are 1.5 m long with a maximum diameter of 0.3 m (Fig. 1). The buoys were tracked using the Argos Satellite-Based Data Collection and Platform Location System. Since 1979 this system has provided a method for remotely tracking Langrangian buoys on a global basis (Rosso, 1983). The position of a buoy is calculated from the Doppler shift of its radio signal frequency as it reaches a satellite. This position, as calculated by Service Argos, is accurate to $+ 0.22 \text{ km}$ (Reynolds and Pease, 1982).

*GLERL Contribution No. 469

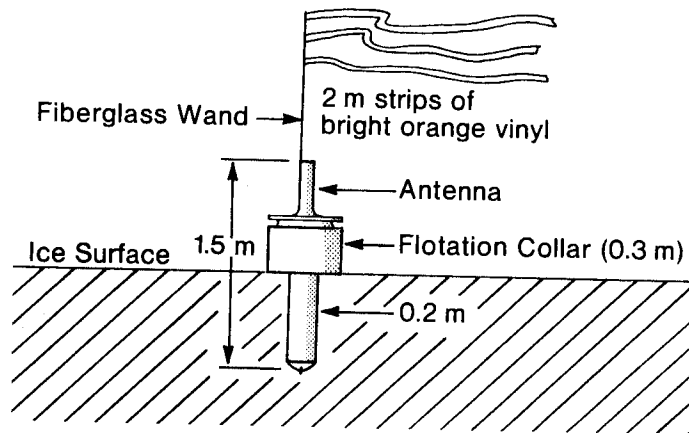

Figure 1.--The Argos-transmitting buoy with orange flagging.

Two drifting buoys were deployed in mid-January when the ice cover was solid. Because of prevailing southwest winds, easterly movement of the ice was anticipated and the buoys were placed approximately 10 km apart in the central basin of Lake Erie to achieve maximum range of movement. After movement of the buoys was observed for 1 week, two more buoys were deployed in the eastern basin to obtain ice drift rates near the Niagara River ice boom. U.S. Coast Guard helicopters were used to deploy drifting buoys on the lake ice. Ice thickness measurements were made at four to six locations within 20 m of the buoy deployment sites.

Once the buoys had been placed in the ice, the assumption was that buoy movement implied ice movement. It was necessary, however, to observe the ice conditions at bi-monthly intervals to determine whether the buoys were still in ice or had moved into open water. A visual search was performed at the last known position of each buoy. If a buoy was not found, the ice conditions were photographed and the ice thickness was measured in the general vicinity of the buoy's last known position.

The Ice Reconnaissance Group at Atmospheric Environment Service, Environment Canada, was provided with updated buoy positions so that weekly visual reconnaissance missions could try to encompass our area of interest. These missions provided us with 70-mm vertical, black-and-white prints of ice in the vicinity of the buoys. Reports of ice thickness made by the Corps of Engineers, Buffalo District, were also used.

Throughout the experiment, four buoys transmitted data that provided information on ice movement from 9 to 58 days. During a 26-day period three buoys provided information from different parts of the lake. This subset of the data is analyzed in the following sections.

3. RESULTS

The experiment began on 12 January 1984 and ended on 13 May 1984. From 31 January to 25 February (26 days), 3 of the 4 buoys provided continuous information. Table 1 summarizes buoy histories throughout the experiment.

Table 1.--Buoy histories

Buoy No.	Deployed	Stopped	Restarted	Recovered
87	12/1/84	21/1/84	--	20/4/84
88	31/1/84	25/2/84	7/4/84	13/5/84
89	21/1/84	27/2/84	17/4/84	19/4/84
98	31/1/84	--	--	19/4/84

The study area included central and eastern basins of Lake Erie (Fig. 2).

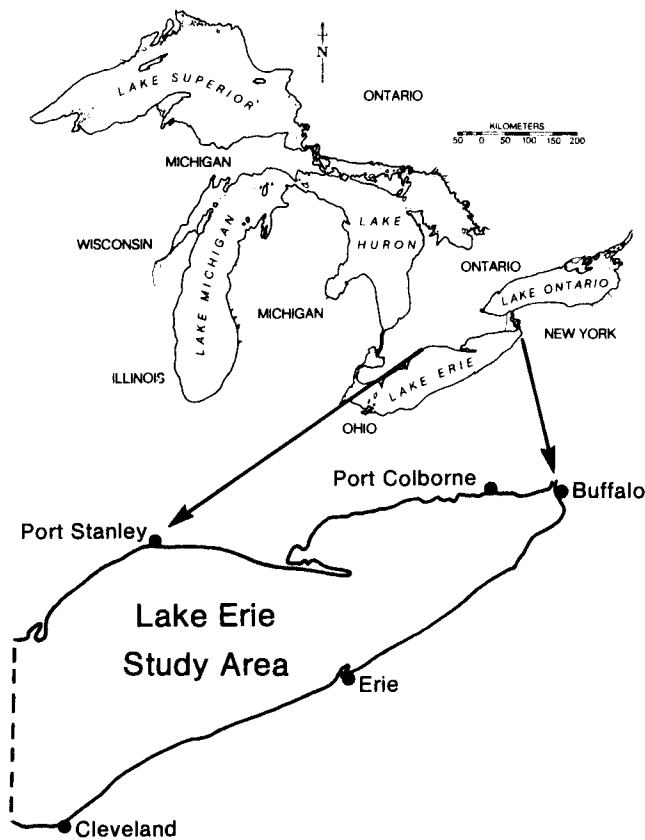

Figure 2.--The Lake Erie study site.

Periodic observations of the ice cover surrounding the buoys confirmed that they remained in the ice and not open water. From successive buoy positions velocity of the ice cover was determined. Tracks of buoy movement for the entire experiment are shown in Figure 3a, the shorter tracks corresponding to the 26-day overlap appear in Figure 3b. Buoy speeds ranged from 0.3 cm s^{-1} to 41.9 cm s^{-1} . Figure 4 is a histogram of buoy speeds.

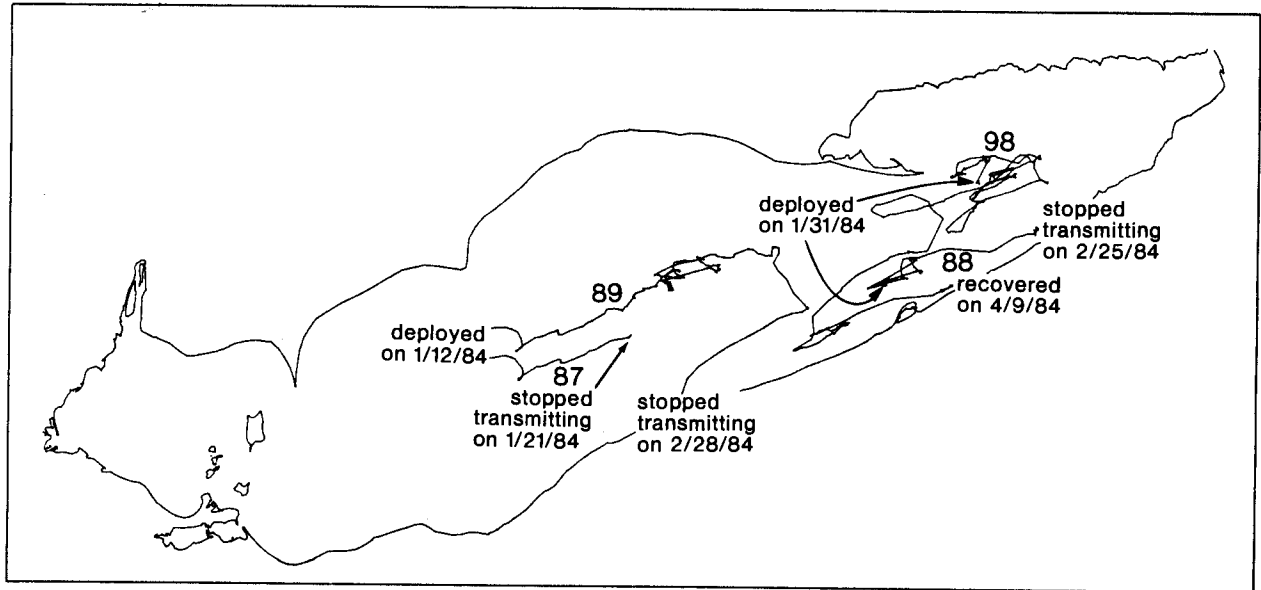

Figure 3a.--The unedited tracks of buoy movement.

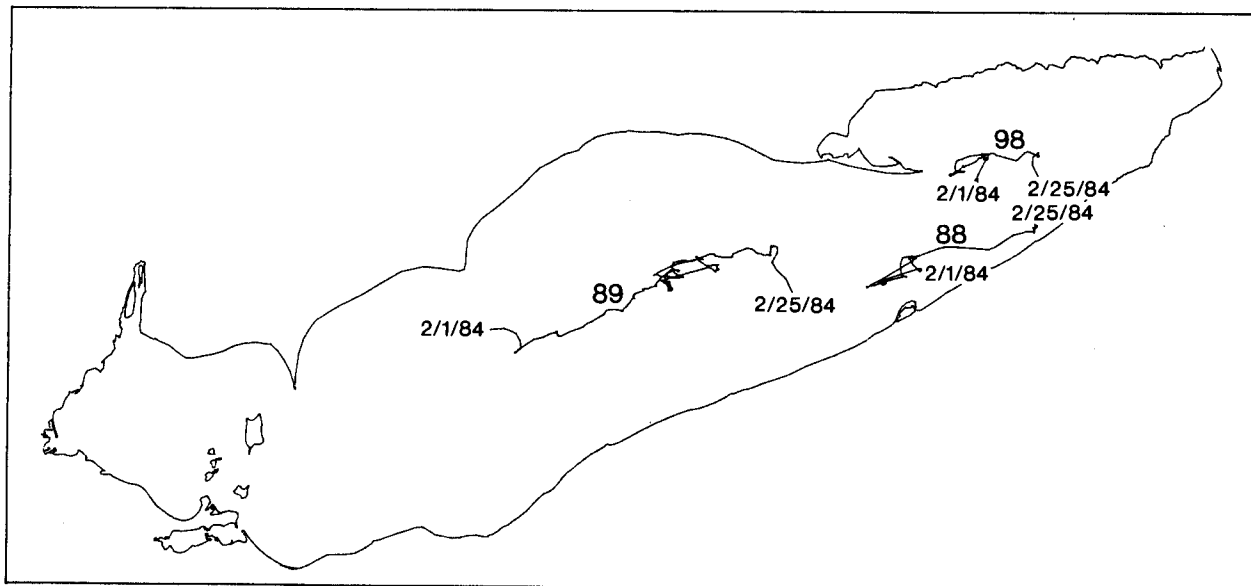

Figure 3b.--The edited tracks of buoy movement.

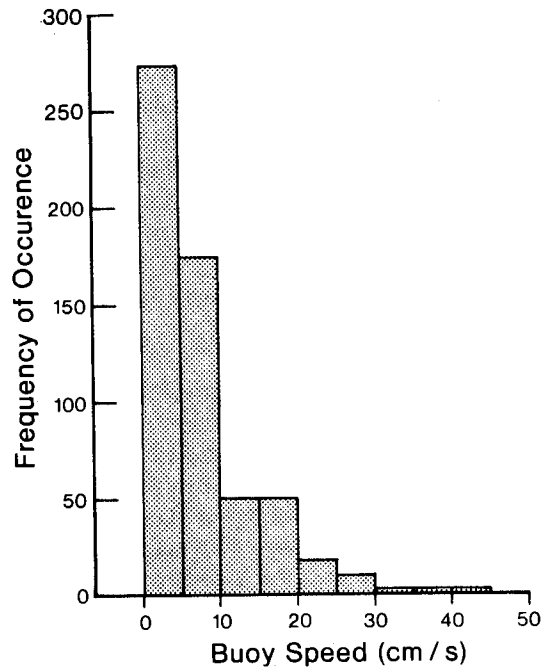

Figure 4.--A histogram of buoy speeds.

The observed ice cover for the eastern two-thirds of Lake Erie and the interpolated ice cover for the whole lake are illustrated in Appendix A. These maps also display ice thickness measurements, buoy location, and areas of ice ridging and rafting. Although these figures are not analyzed in detail in this report, they are included as part of the background data that would be required in addition to the drifter data for ice model calibration and verification.

Wind information was obtained from the airport at Erie, Pa. The velocity vectors for three buoys and the wind vectors are plotted in Appendix B.

4. DISCUSSION

The histogram of buoy speeds (Fig. 4) shows a bias toward the lower end, and the majority between 0 and 5 cm s^{-1} . Similar distributions were seen when the same buoys were used in the open water of Lake Michigan (Pickett et al., 1983). The mean observed speed of the buoys in ice was 8 cm s^{-1} . This is considerably higher than we expected, amounting to almost half the mean speed of 17 cm s^{-1} observed in the open water of Lake Michigan. Although the frequency of occurrence of higher speeds ($> 20 \text{ cm s}^{-1}$) is much less when the

buoys are in ice, it is notable that speeds as high as 46 cm s^{-1} were observed and that 6.5% of all observed speeds were greater than 20 cm s^{-1} .

In Appendix B, the direction of buoy movement does not appear to correlate directly with wind direction. The wind measurements were taken from the Erie, Pa., airport; buoy measurement were taken at mid-lake positions. Although the spatial separation of the measurements could be used to explain the differences, we believe that the ice movement may be more closely related to the direction of the current that would result from the wind on an ice-free lake than to the wind directly. It is well known that mid-lake currents can be opposed to the wind direction in typical wind-induced circulation patterns in the Great Lakes (Pickett, 1980). From Appendix B it appears that this sort of mechanism must govern ice movement as well.

Equipment failure and relocation techniques were limiting factors in this experiment. Lithium batteries would have lasted longer than alkaline and provided more continuous data. The aluminum hull and fiberglass antenna were often not able to withstand the large forces exerted by the ice during ridging and rafting. Two of the hulls were smashed, allowing water to penetrate and destroy the electronics inside. The other two suffered superficial damage. In addition, there was difficulty with the relocation of the buoys after deployment. During this study several systems of relocation were attempted. The first was to attach a fiberglass wand with fluorescent orange flagging to the antennas of the buoys (Fig. 1). Search patterns were flown perpendicular to the wind beginning at the last reported position. This was done to provide maximum visibility from the flagging. Only one attempt was successful. Next, a large ($15 \text{ m} \times 1 \text{ m}$) fluorescent orange tarp was anchored on the ice beside one of the buoys. We hoped this would simplify the visual search. Again we found it inadequate. Fluorescent dye was tested for its marking abilities on the ice; it percolated through the porous surface and was indiscernible within 24 h of use. If the experiments were repeated and relocation of the buoys necessary, affixing a small, continuously transmitting radio to the buoy, which could be relocated with a receiver used from the helicopter, would be recommended.

5. SUMMARY

From 31 January to 25 February 1984, three Argos drifting buoys reported ice movement on central and eastern Lake Erie. Observed speeds ranged between 0 and 46 cm s^{-1} with a mean speed of 8 cm s^{-1} . Movement of the ice did not appear to be correlated with winds measured onshore. We suspect this is due to the movement of ice in a pattern similar to wind-induced circulation patterns in an ice-free lake, which frequently show mid-lake currents opposed to the wind direction (Pickett, 1980). In future experiments on ice movement using satellite-tracked drifting buoys, it would be advisable to use lithium batteries, more durable housings, and a small continuously transmitting radio location beacon on each platform.

6. REFERENCES

- McNutt, L., 1981. Ice conditions in the Eastern Bering Sea from NOAA and Landsat imagery: Winter conditions 1974, 1976, 1977, 1979. NOAA Tech. Memo. ERL PMEL-24, 179pp. National Technical Information Service, Springfield, VA 22161.
- Pickett, R.L., 1980. Observed and predicted Great Lakes winter circulations. J. Phys. Oceanogr. 10(7):1140-1145.
- Pickett, R.L., J.E Campbell, and A.H. Clites, 1983. Satellite-tracked current drifters in Lake Michigan. J. Great Lakes Res. 9(1):106-108.
- Quinn, F.H., R.A. Assel, and D.W. Gaskill, 1980. An evaluation of climatic impact of the Niagara Ice Boom relative to air water temperature and winter severity. NOAA Tech. Memo. ERL GLERL-30, 31 pp. National Technical Information Service, Springfield, VA 22161.
- Quinn, F.H., R.A. Assel, and D.W. Gaskill, 1982. An evaluation of the impact of the Niagara River Ice Boom on the air temperature regime at Buffalo, New York. J. Appl. Meteorol. 21(3):342-349.
- Reynolds, M., and C. Pease, 1982. Drift characteristics of northeastern Bering Sea ice during 1982. NOAA Tech. Memo. ERL PMEL-55, 135 pp. National Technical Information Service, Springfield, VA 22161.
- Rosso, R., 1983. The Argos Data Collection and Location System: Ocean applications. Proceedings, 1983 Symposium on Buoy Technology, New Orleans, LA, April 1983, 1-5.
- Rumer, R.R., 1973. Mathematical model for ice dissipation process. Appendix Report to the International Niagara Working Committee, Contract No. DACW49-73-C-0086.
- Rumer, R.R., 1980. An analysis of the document prepared by Ecology and Environment, Inc., entitled The influence of the Niagara River Ice Boom on gas energy demand.
- Rumer, R.R., and Acres Consulting Services Limited, 1974. Lake Erie-Niagara River Ice Boom Study. International Niagara Board of Control, January 1974.
- Rumer, R.R., and P.M. Yu, 1978. Modelling ice dissipation in eastern Lake Erie. J. Great Lakes Res. 4(2):194-200.
- Rumer, R., C. Atkinson, and S.T. Lavender, 1975. Effects of Lake Erie-Niagara River Ice Boom on the ice regime of Lake Erie. Proceedings, 3rd International Symposium on Ice Problems, IAHR, Hanover, NH, 289-300.
- Rumer, R.R., A. Wake, S.H. Chieh, and R.D. Crissman, 1981. Development of an ice transport model for Great Lakes application. Proceedings, 6th Conference on Port and Ocean Engineering under Arctic Conditions, Vol. II, Universite Laval, Quebec, Canada, 892-900.

Wake, A., and R. Rumer, 1979. Modelling the ice regime of Lake Erie. J. Hydraul. Div. 105:827-844.

Wake, A., and R. Rumer, 1983. Great Lakes ice dynamics simulation. J. Waterw. Port Coast. Ocean Eng. 109(1):86-102.

Appendix A: The observed and interpolated Lake Erie 1984 ice conditions

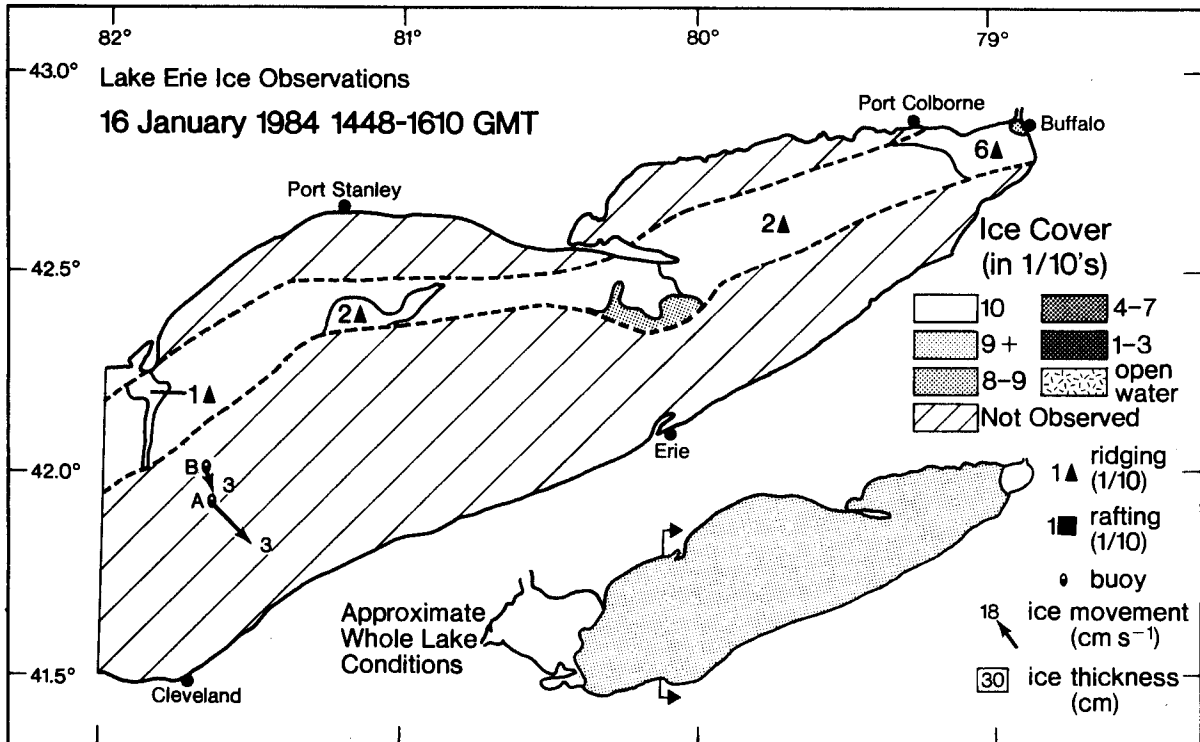
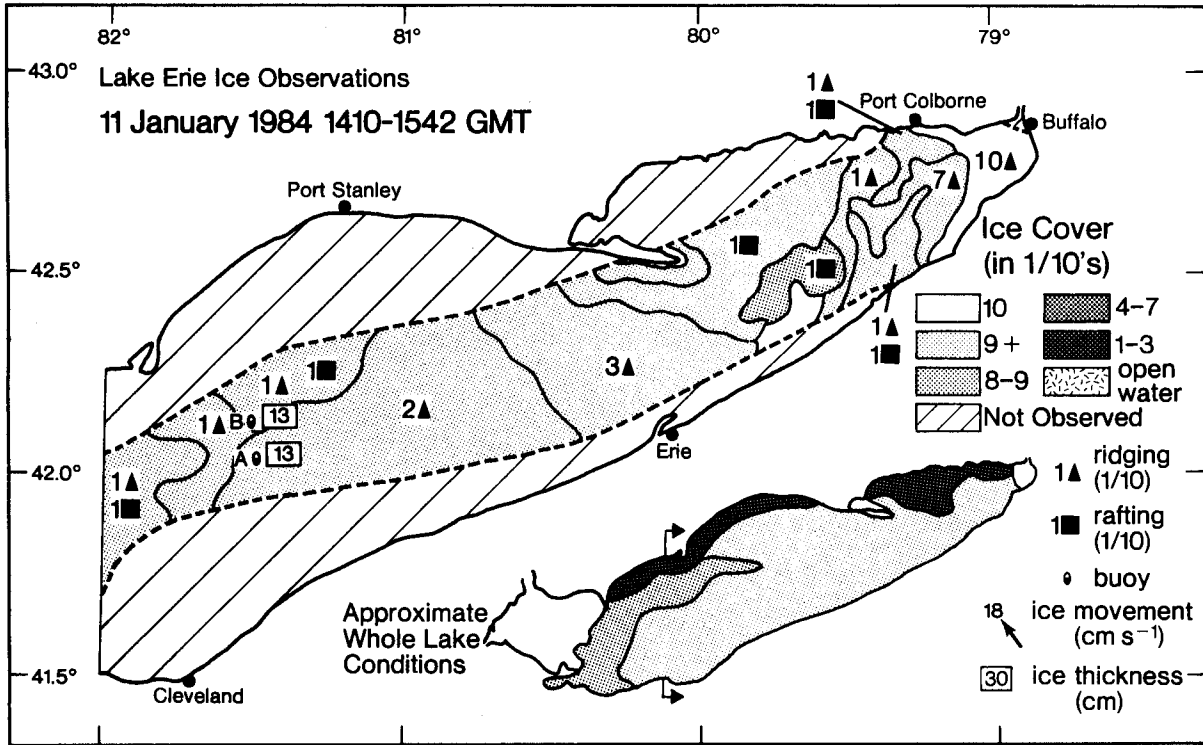

Figure A.--The observed and interpolated Lake Erie 1984 ice conditions.

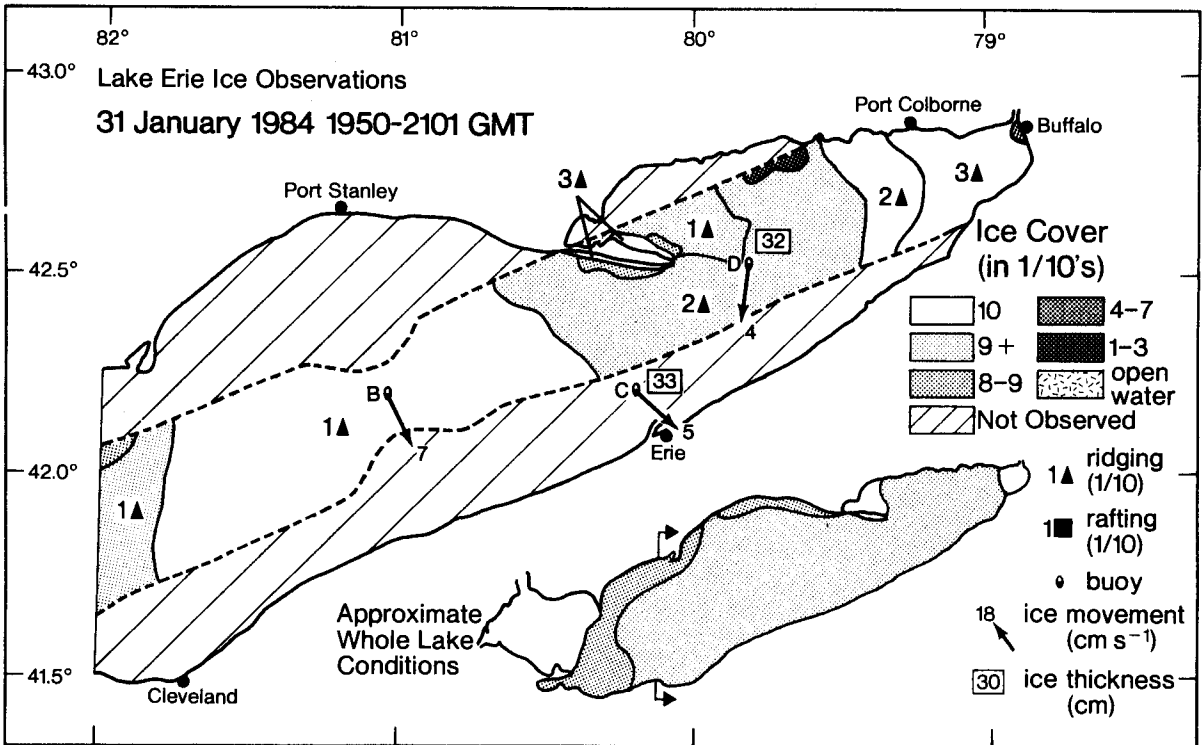
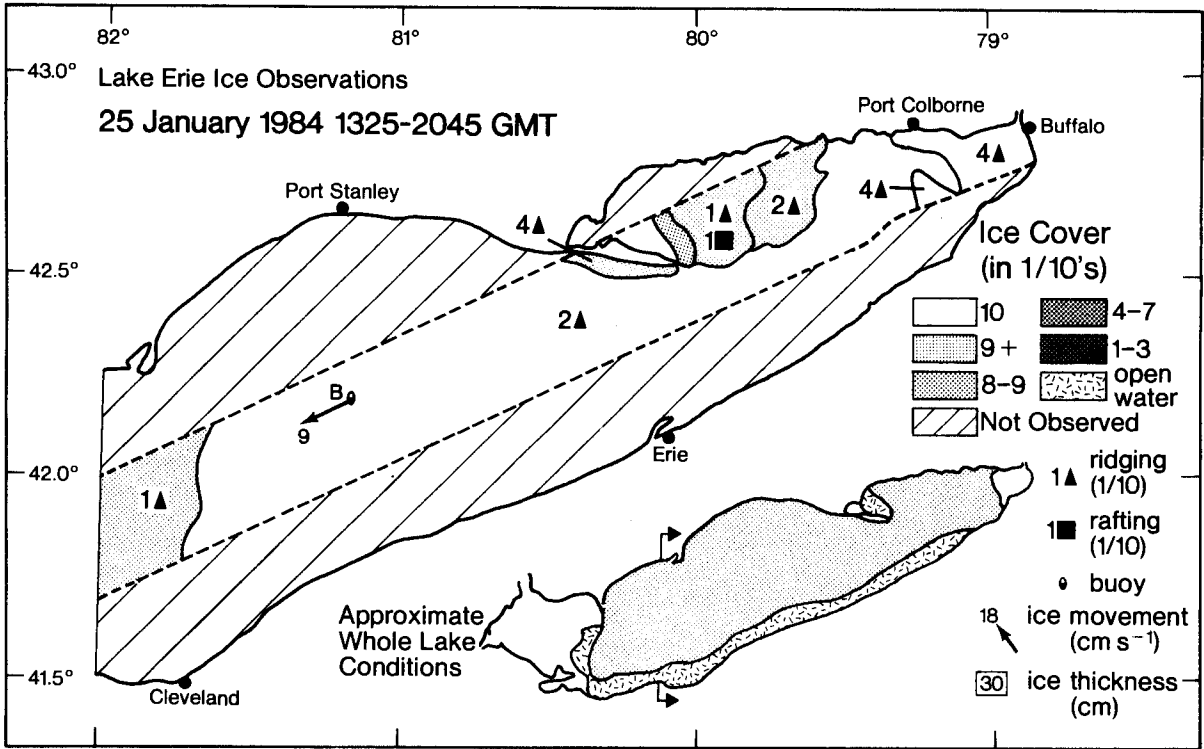

Figure A con.--The observed and interpolated Lake Erie 1984 ice conditions.

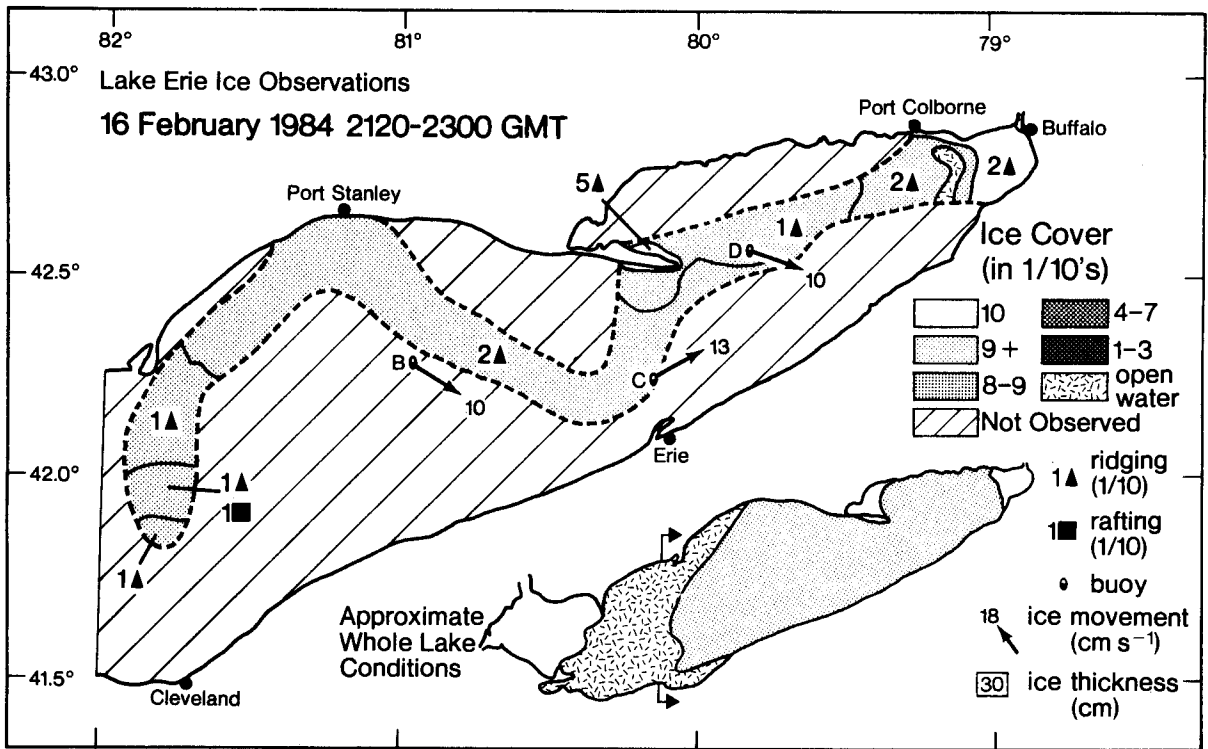
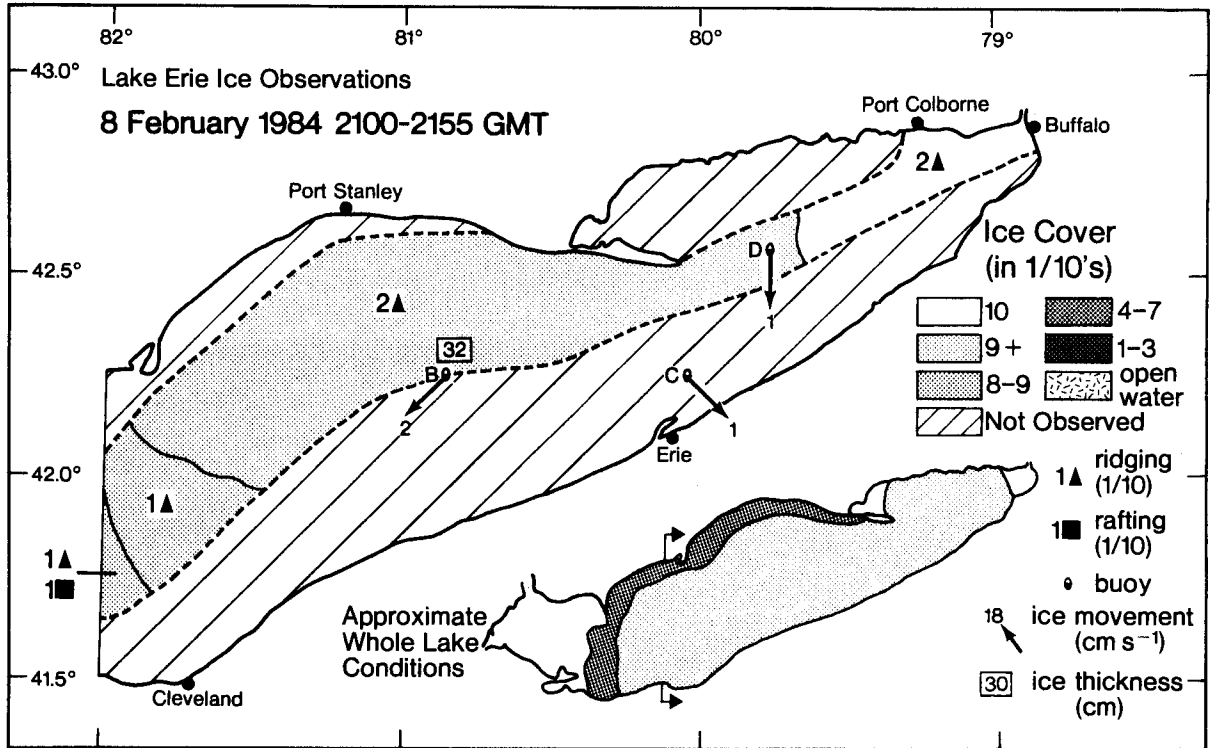

Figure A con.--The observed and interpolated Lake Erie 1984 ice conditions.

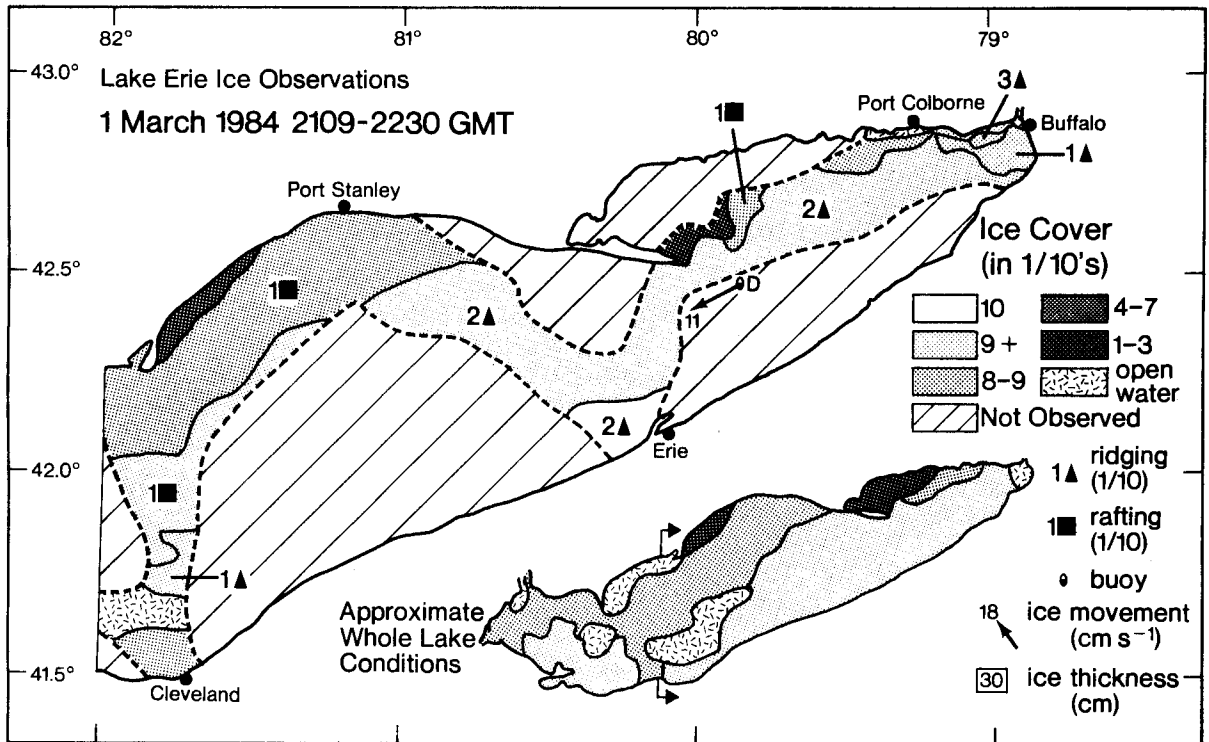
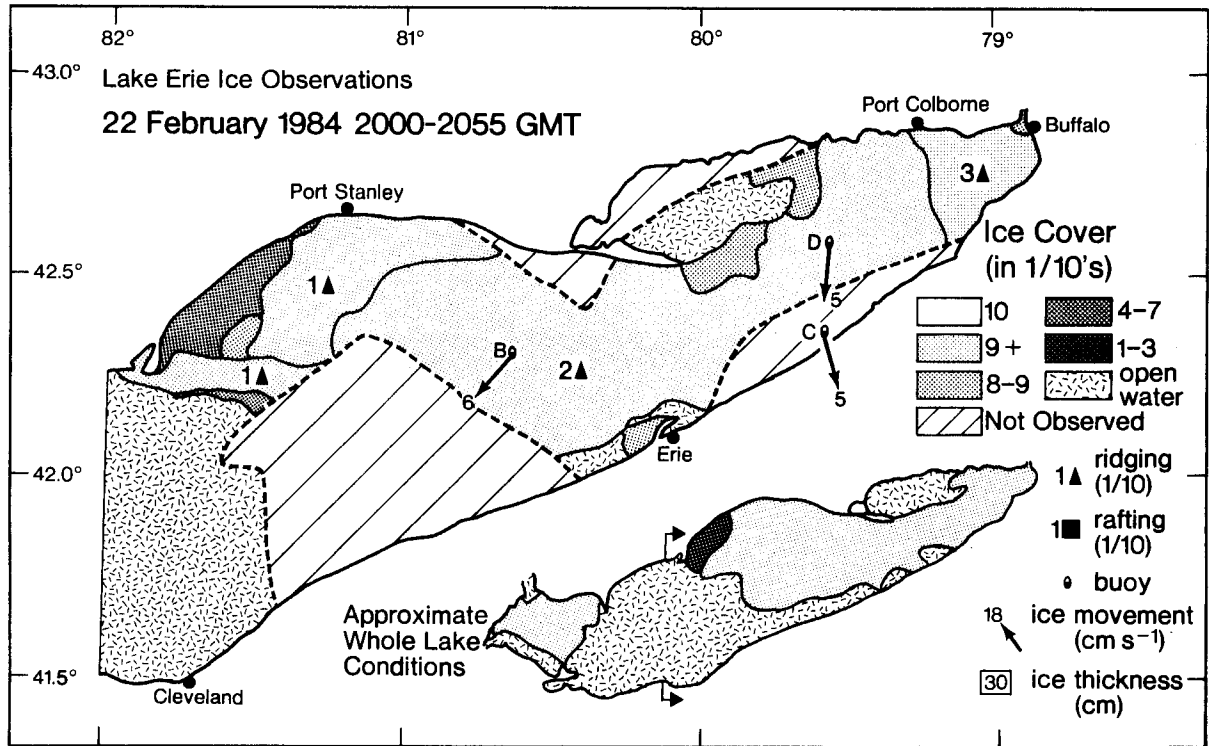

Figure A con.--The observed and interpolated Lake Erie 1984 ice conditions.

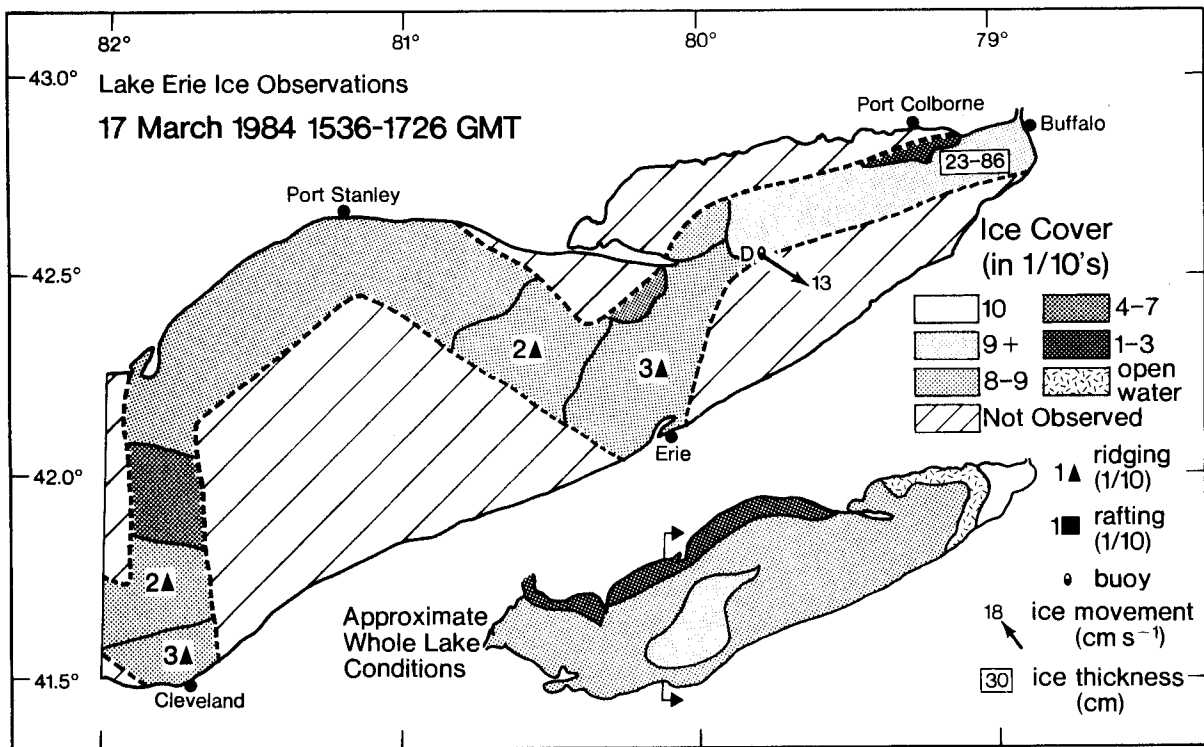
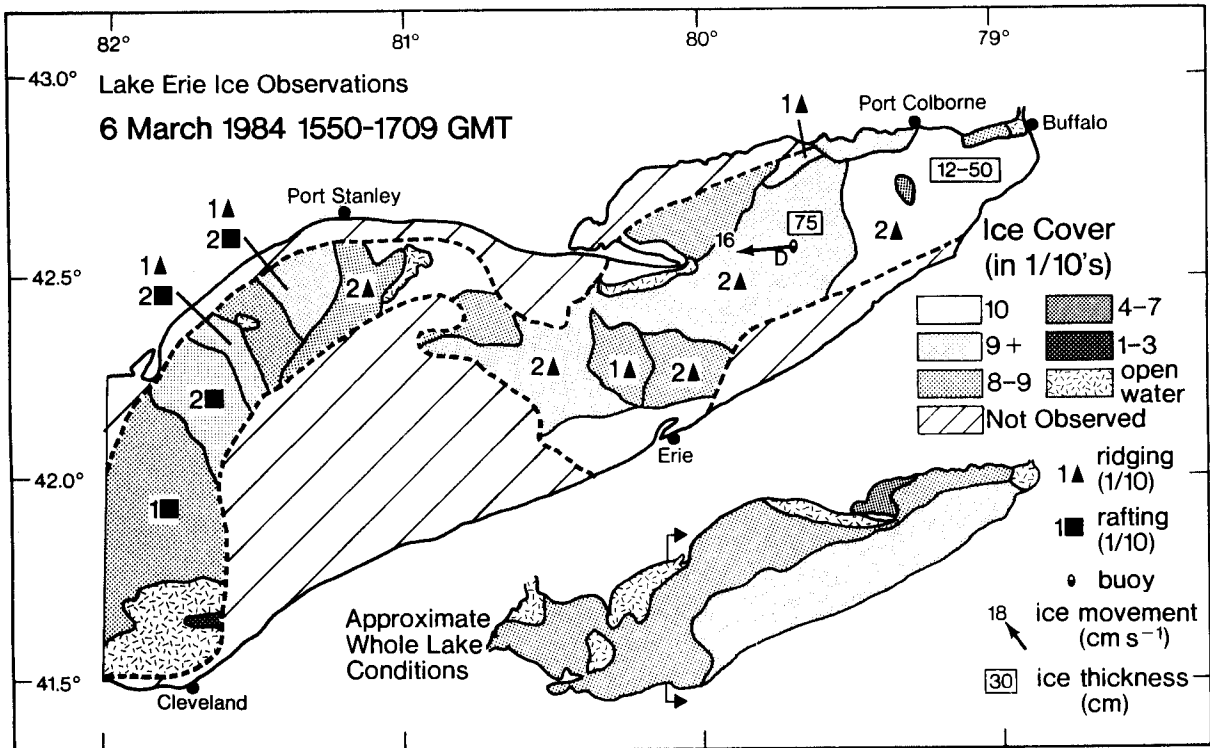

Figure A con.--The observed and interpolated Lake Erie 1984 ice conditions.

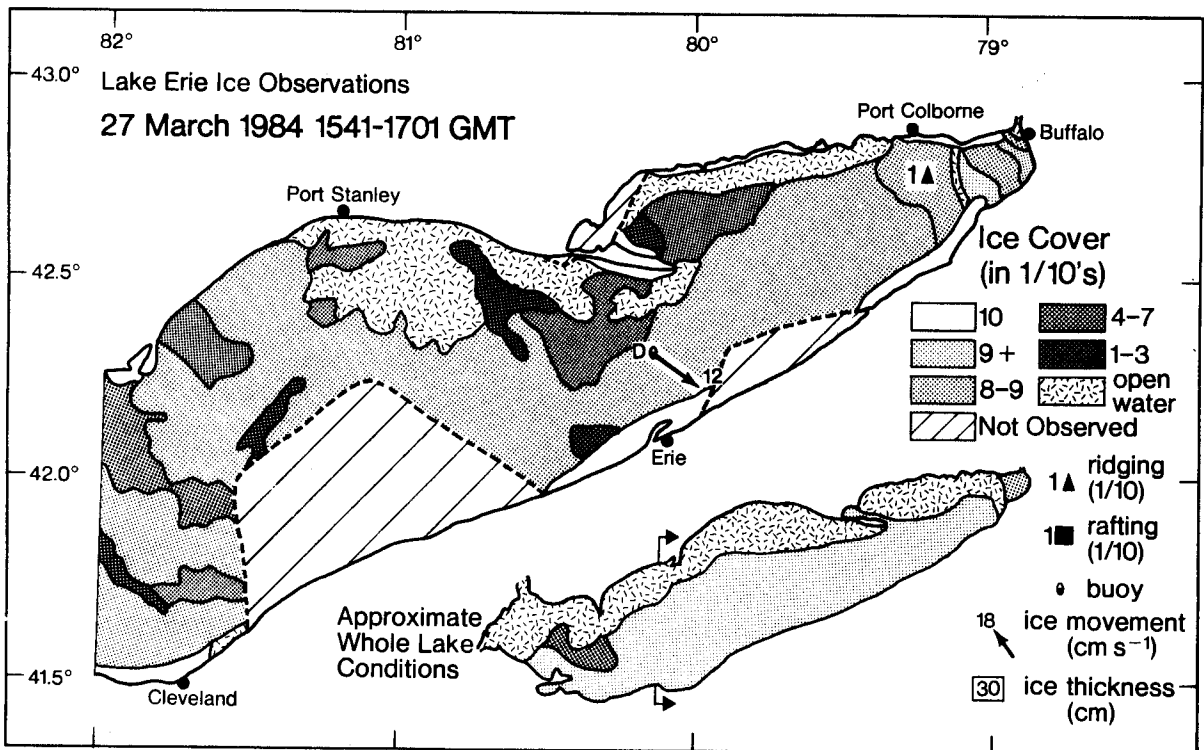
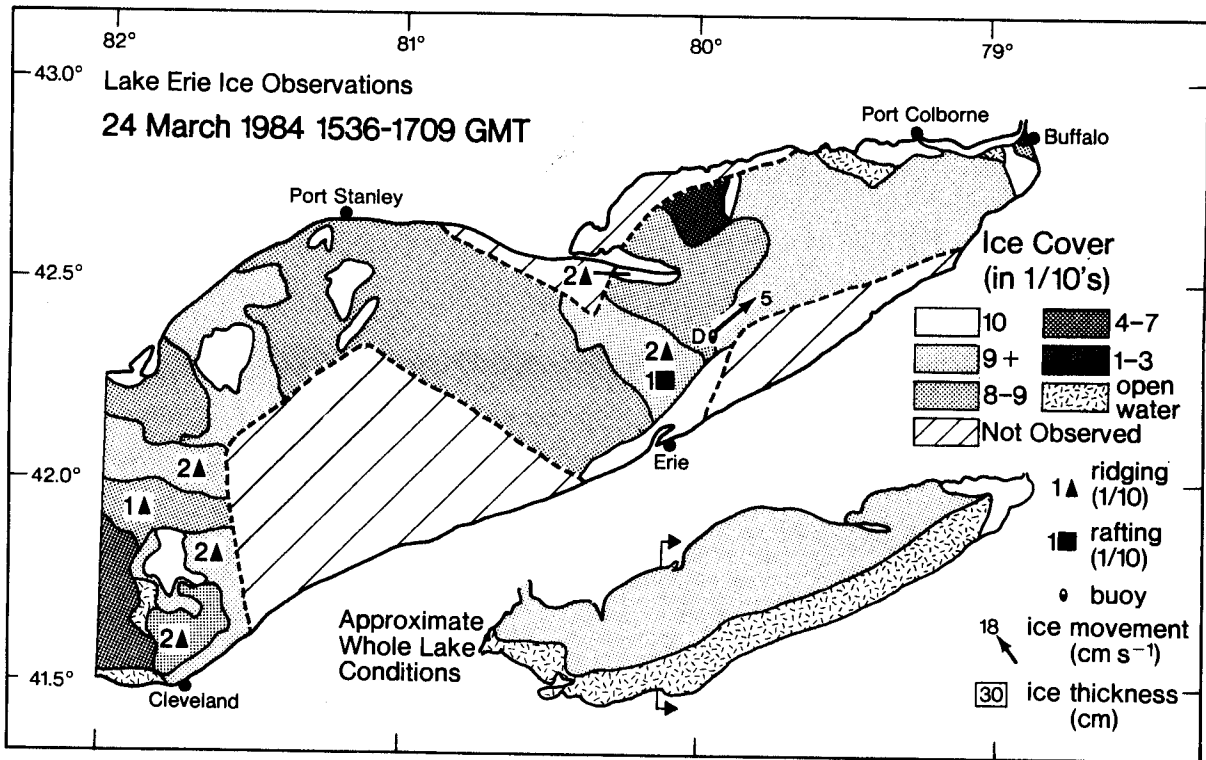

Figure A con.--The observed and interpolated Lake Erie 1984 ice conditions.

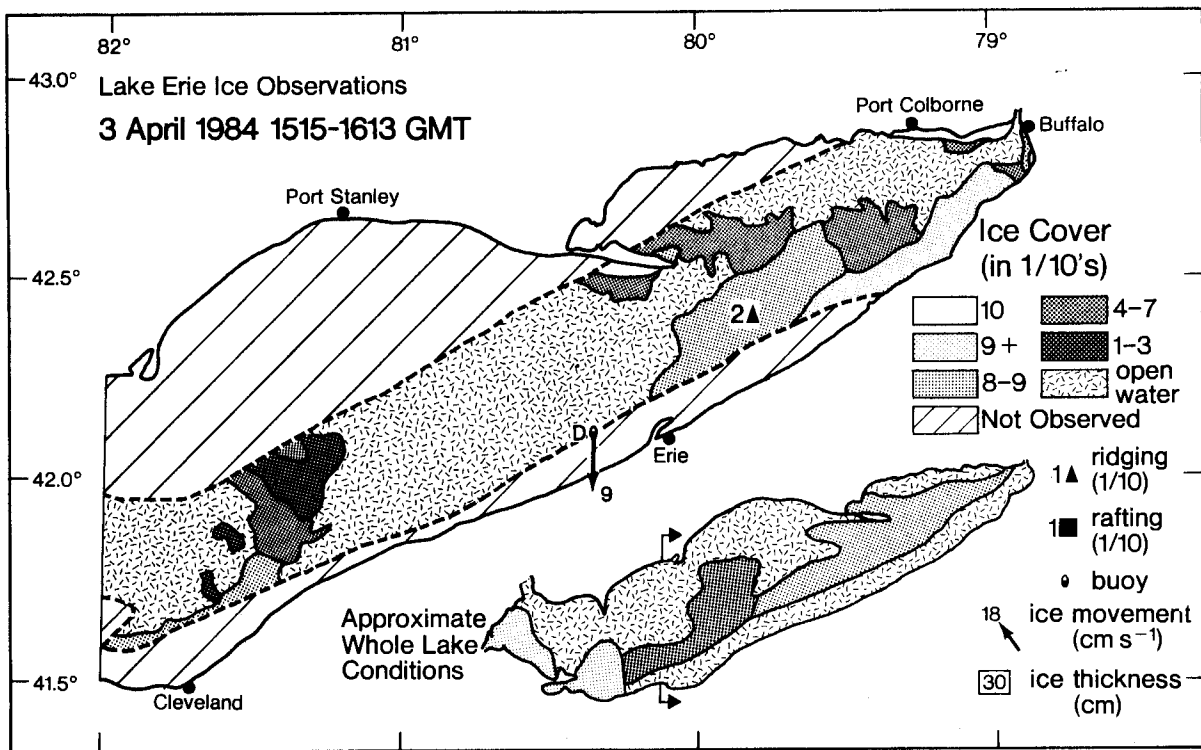
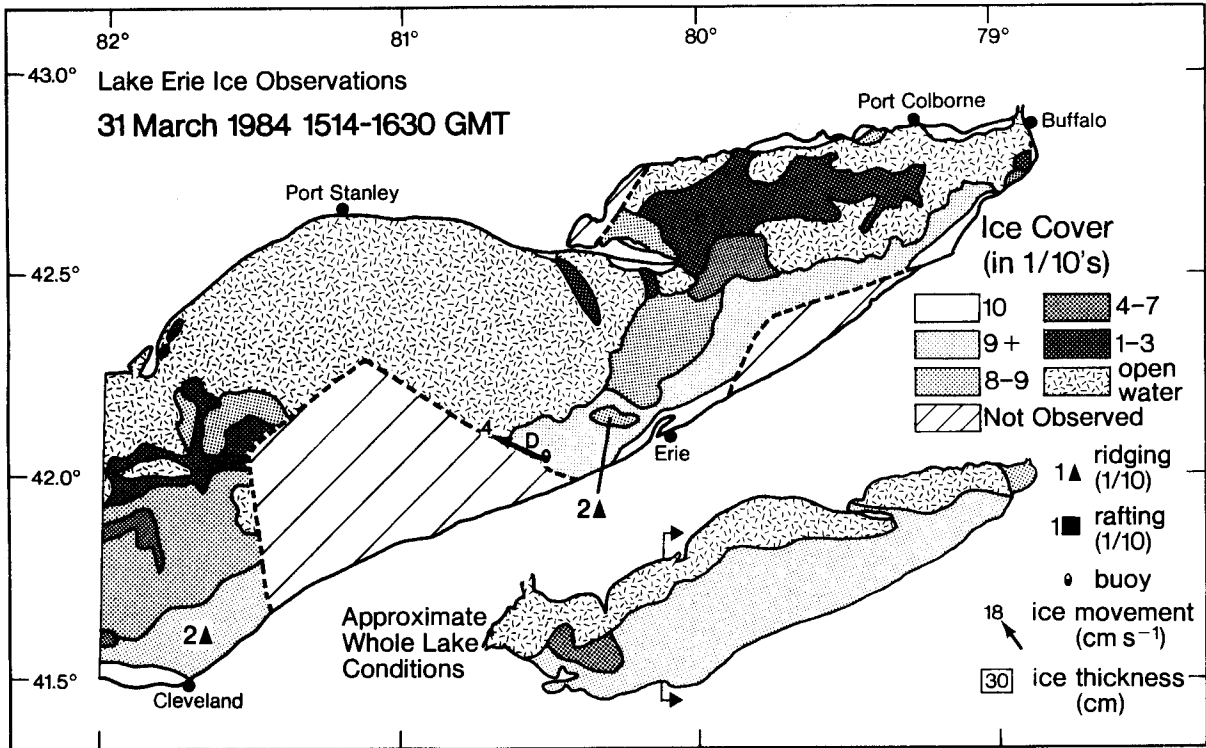

Figure A con.--The observed and interpolated Lake Erie 1984 ice conditions.

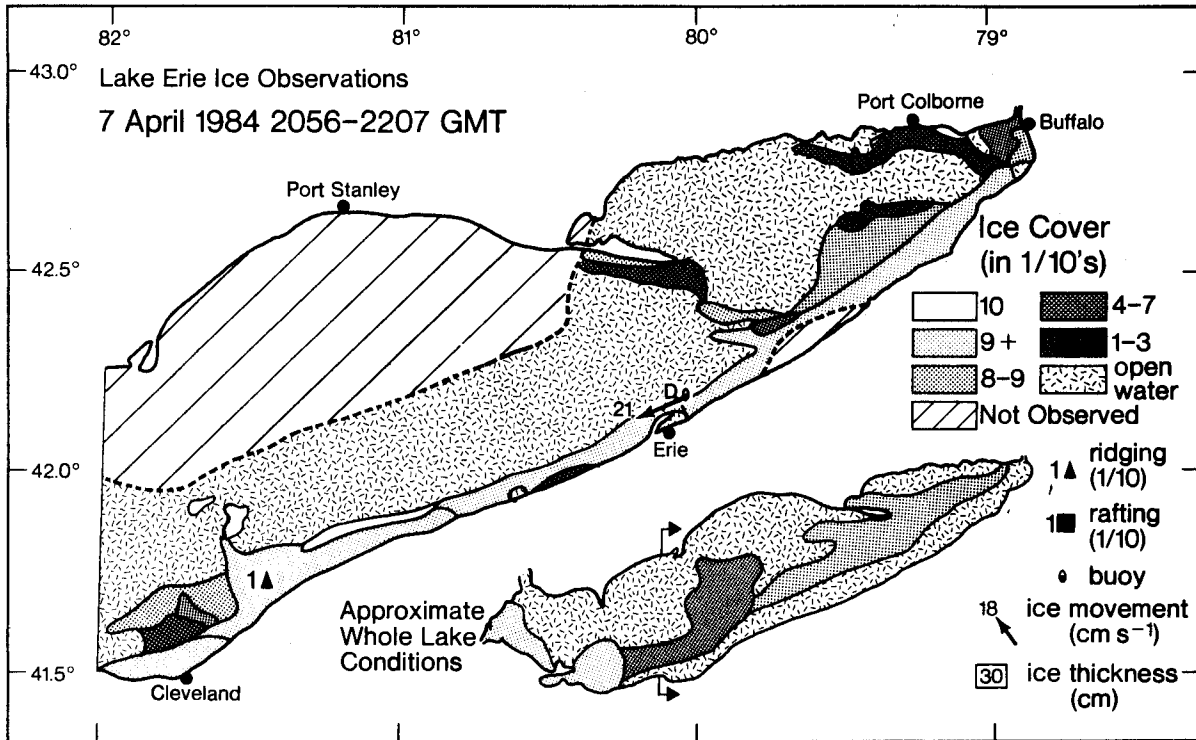

Figure A con.--The observed and interpolated Lake Erie 1984 ice conditions.

Appendix B: Buoy and Wind Velocities

(Buoy velocities are in cm s^{-1} at 1-h intervals; wind velocities are in m/s at 3-h intervals)

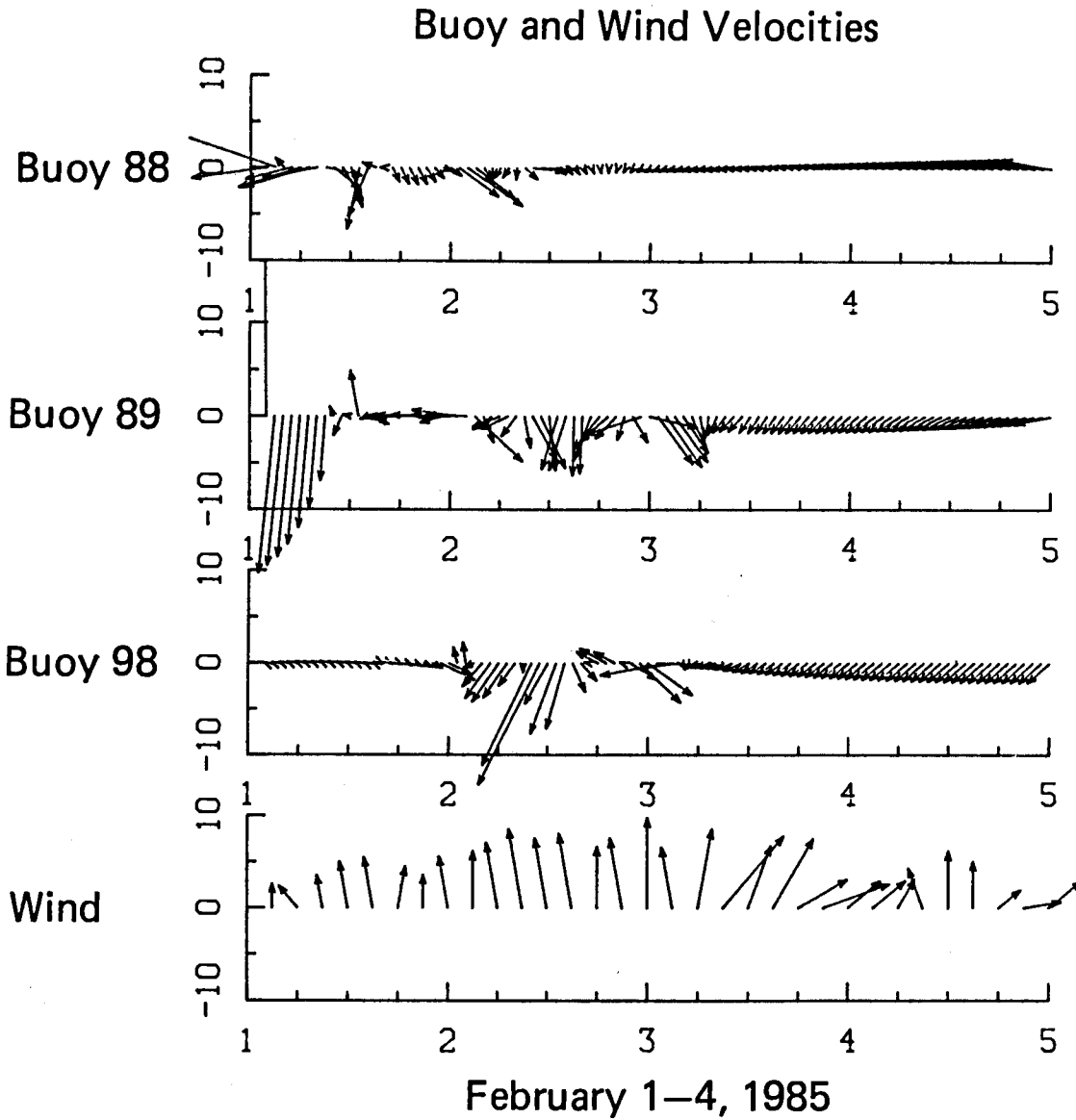

Figure B. The buoy and wind velocity vectors for 1-4 February 1985.

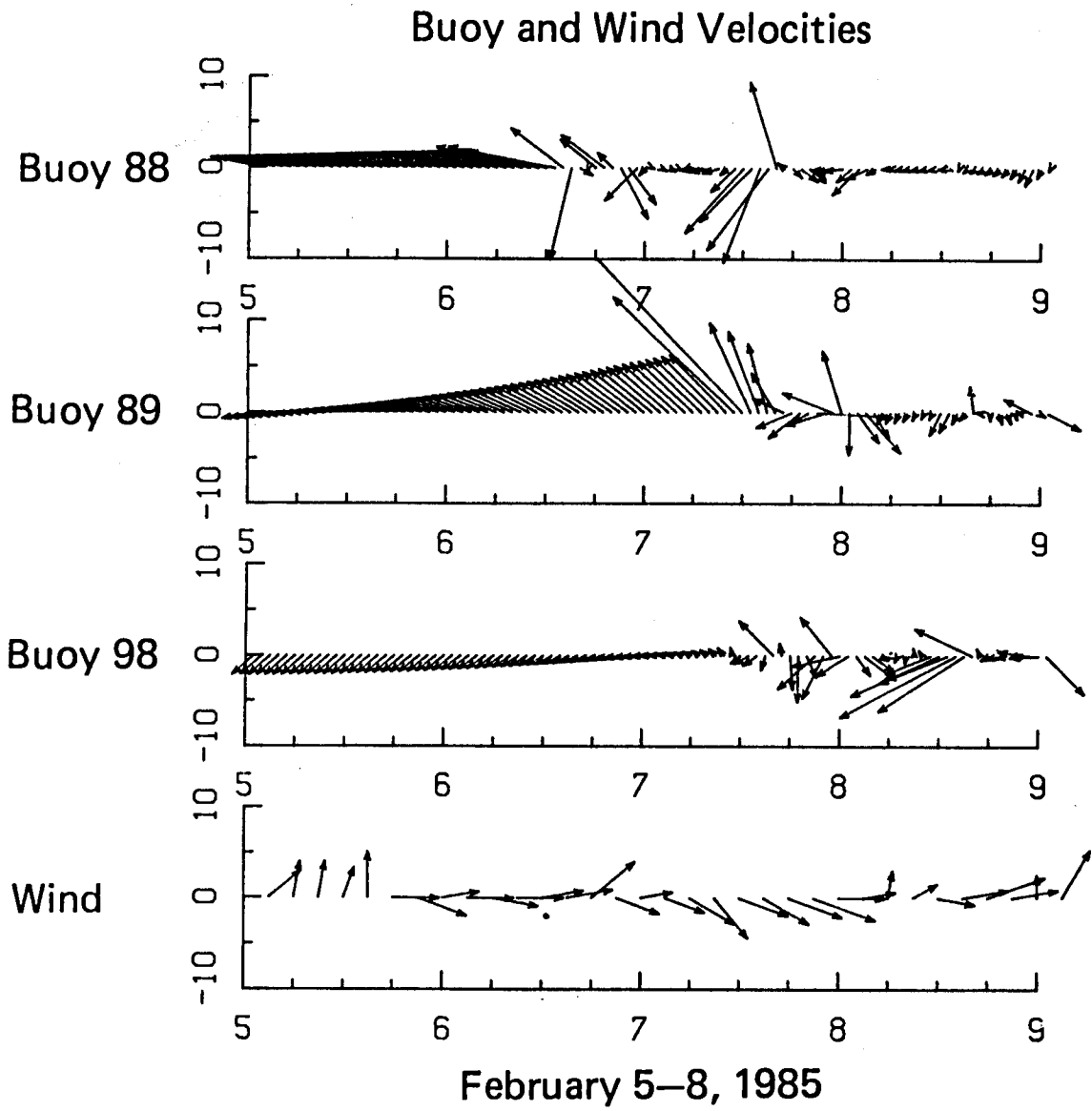

Figure B con.--The buoy and wind velocity vectors for 5-8 February 1985.

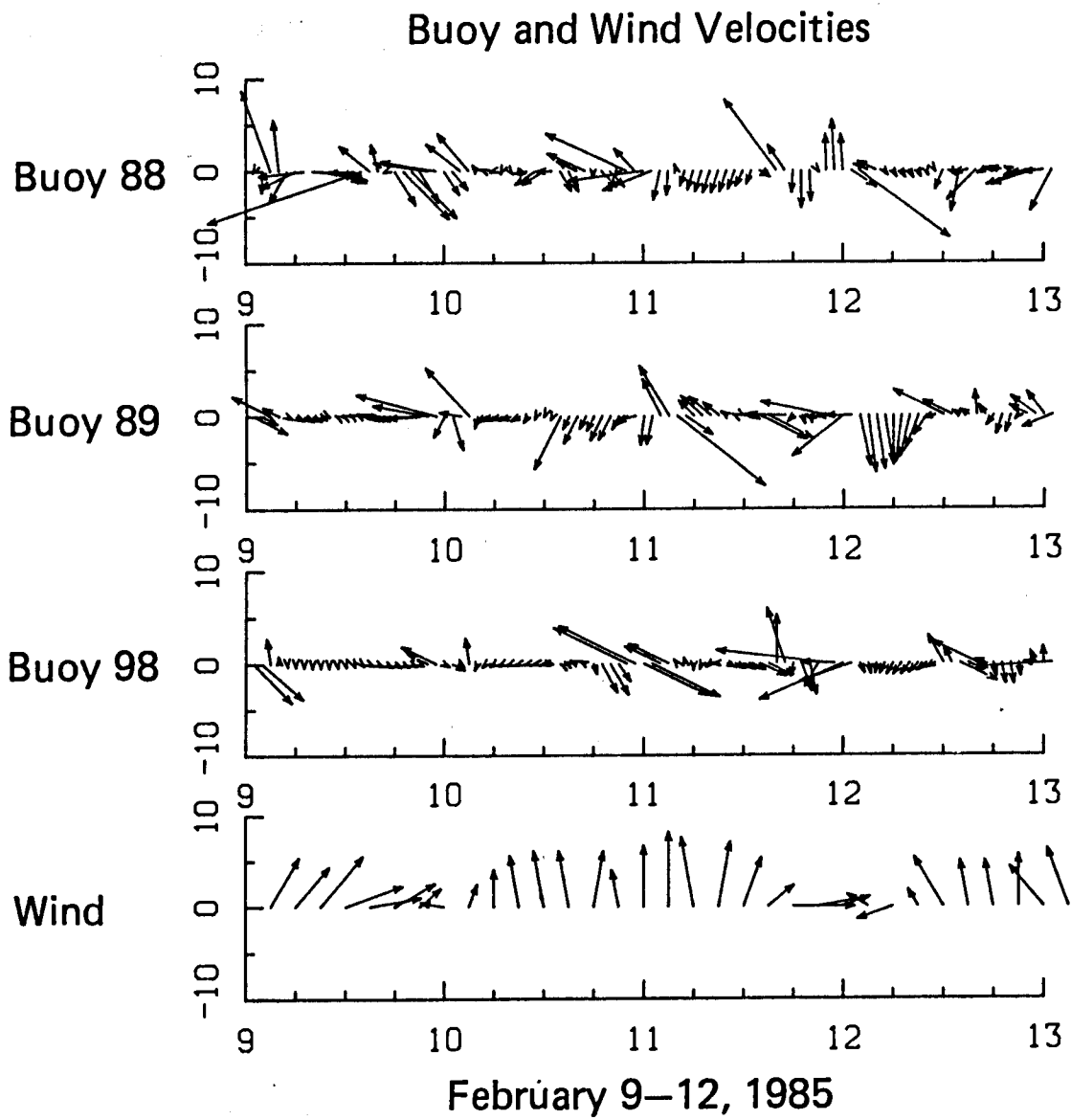

Figure B con.--The buoy and wind velocity vectors for 9-12 February 1985.

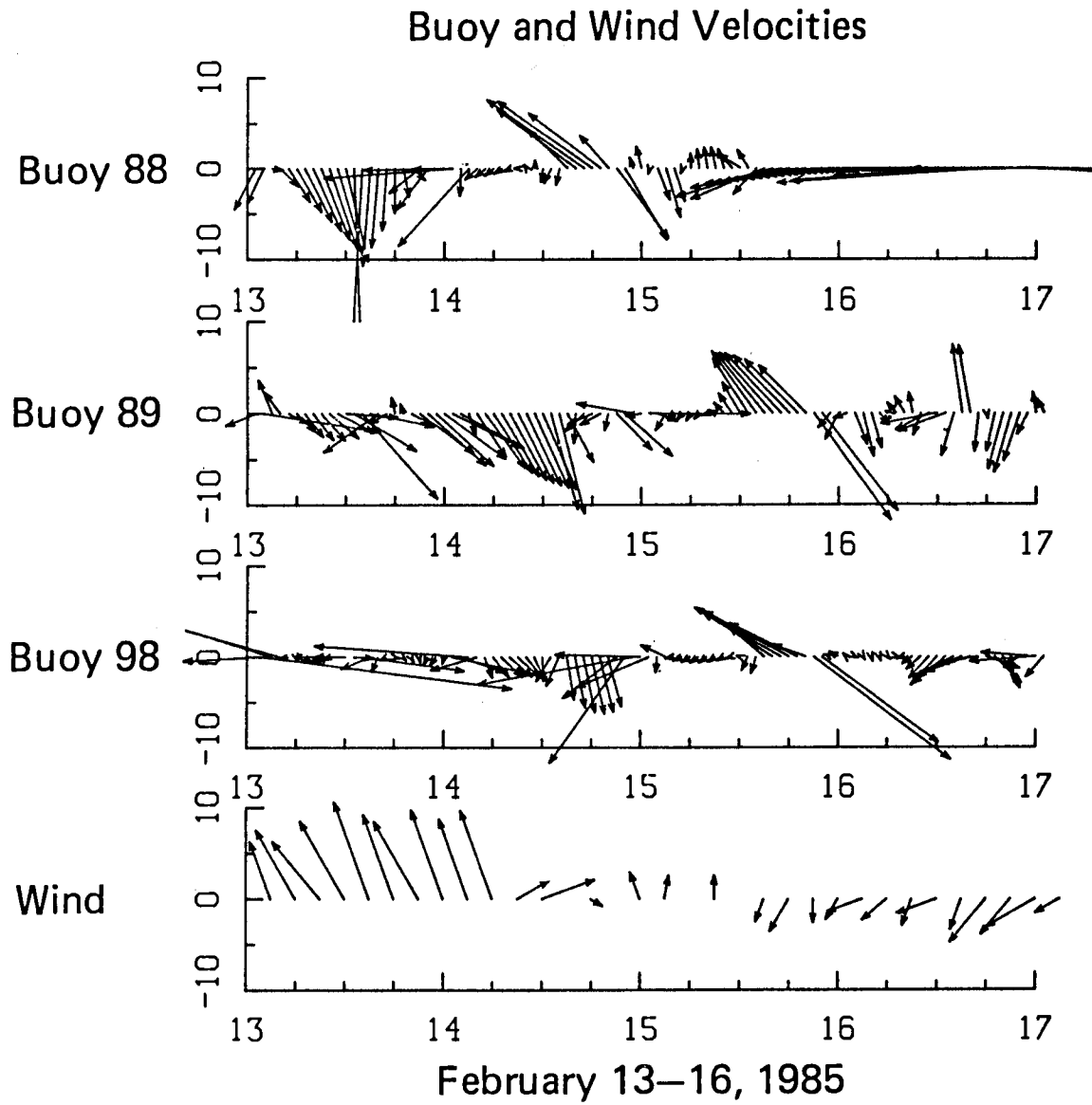

Figure B con.--The buoy and wind velocity vectors for 13-16 February 1985.

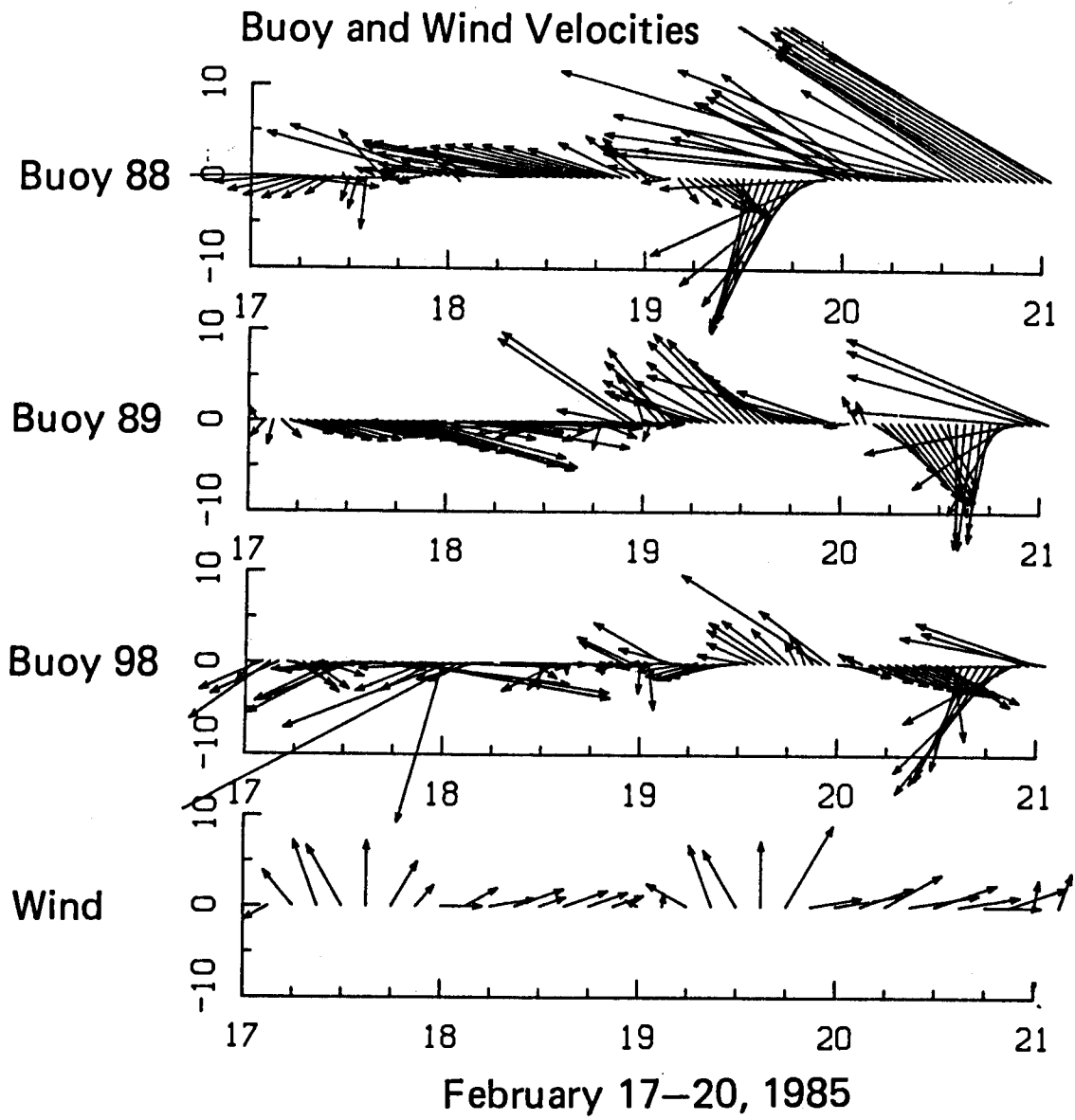

Figure B con.--The buoy and wind velocity vectors for 17-20 February 1985.

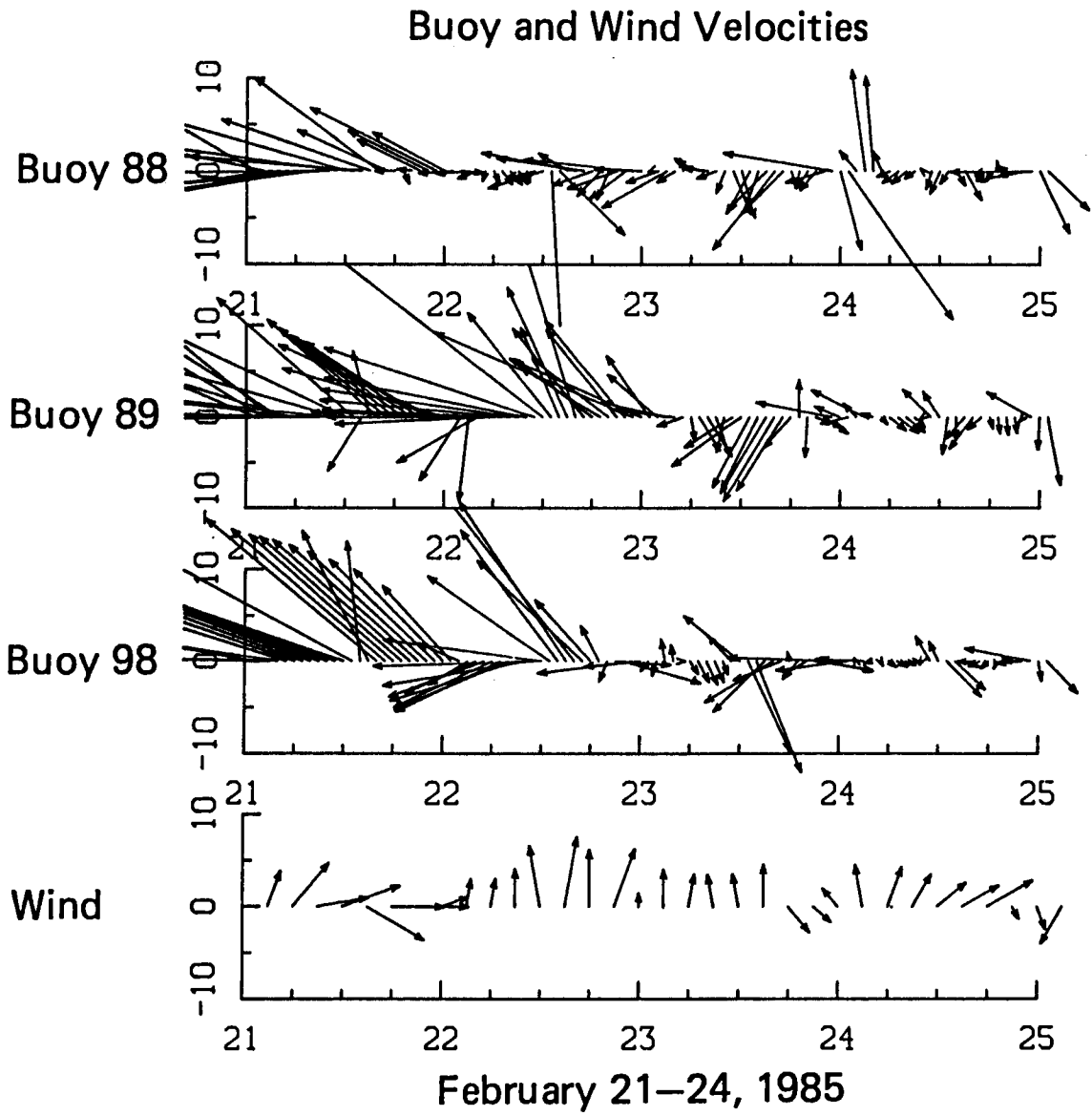

Figure B con.--The buoy and wind velocity vectors for 21-24 February 1985.