

San Antonio and Bexar County Digital Inclusion Roadmap

Fact-base & Compendium

JUNE 2021

Table of contents

3	Fact-base
4	Summary
6	Interviews and Community Engagement
19	Inventory Survey
28	K-12 Questionnaire
33	Size and Nature of the Digital Divide
47	ISP Economics & Engagement
56	Initiative Details
57	Infrastructure
93	Affordable Housing Access
104	Education Sponsored
127	Low-income Internet
149	Device Support
162	Adoption Support
191	Data & Analytics
214	Operating Model
244	Population Segments
250	Implementation Roadmap
273	Funding Databases
290	Asset Maps
291	Access Maps
294	Coverage Maps
300	Community Level Maps

Table of contents

3	Fact-base
4	Summary
6	Interviews and Community Engagement
19	Inventory Survey
28	K-12 Questionnaire
33	Size and Nature of the Digital Divide
47	ISP Economics & Engagement
56	Initiative Details
57	Infrastructure
93	Affordable Housing Access
104	Education Sponsored
127	Low-income Internet
149	Device Support
162	Adoption Support
191	Data & Analytics
214	Operating Model
244	Population Segments
250	Implementation Roadmap
273	Funding Databases
290	Asset Maps
291	Access Maps
294	Coverage Maps
300	Community Level Maps

Table of contents

3	Fact-base
4	Summary
6	Interviews and Community Engagement
19	Inventory Survey
28	K-12 Questionnaire
33	Size and Nature of the Digital Divide
47	ISP Economics & Engagement
56	Initiative Details
57	Infrastructure
93	Affordable Housing Access
104	Education Sponsored
127	Low-income Internet
149	Device Support
162	Adoption Support
191	Data & Analytics
214	Operating Model
244	Population Segments
250	Implementation Roadmap
273	Funding Databases
290	Asset Maps
291	Access Maps
294	Coverage Maps
300	Community Level Maps

Preliminary; additional detail
on the following pages

Our fact-base is organized against four core components

Components	Key Takeaway
Size and nature of the need	More than 130K households (20%+) are estimated to lack adequate internet access , however, the true number of COSA / Bexar households who need improved broadband infrastructure and digital inclusion is even higher; gaps in access are largely driven by barriers to affordability and adoption
Many efforts to address the digital divide are underway today	Many local organizations are investing to address the digital divide with a focus on student needs, but better data and coordination are required to effectively deliver a holistic solution
Closing the divide matters for equity & the economy	Closing the divide is critical to reducing systemic inequities (e.g., education, health, workforce) and driving economic growth in public and private sectors
We are in a unique moment to have an impact	There is significant funding at federal, state & local levels to capitalize on and COSA / Bexar are in a position to both have an impact and serve as a model for others; adherence to key principles (e.g., create a cross-sector coalition, productively engage the community/ISPs) will ensure success

Table of contents

3	Fact-base
4	Summary
6	Interviews and Community Engagement
19	Inventory Survey
28	K-12 Questionnaire
33	Size and Nature of the Digital Divide
47	ISP Economics & Engagement
56	Initiative Details
57	Infrastructure
93	Affordable Housing Access
104	Education Sponsored
127	Low-income Internet
149	Device Support
162	Adoption Support
191	Data & Analytics
214	Operating Model
244	Population Segments
250	Implementation Roadmap
273	Funding Databases
290	Asset Maps
291	Access Maps
294	Coverage Maps
300	Community Level Maps

Breakdown on Community Engagement

Community Outreach | Update

Participation Breakdown: 141 Entities Total

113 Community
Organizations/Businesses

28 K-12 Districts/Charters/Organizations

- Survey Responses: 99 total (89 unique)
- One-on-One Meetings: 30
- Focus Groups Participation: 17
- Representation through Advisory Member: 15
- K-12 Questionnaire Responses: 8
- K-12 Focus Groups Participation: 25

Bexar County ISDS & Charter Schools (K-12)

- Chief Technology Officers - Thursday, April 22, 2021
- Superintendent Update - Tuesday, June 2, 2021
E-Rate Updates
- ISD Questionnaire

Target Focus Groups w/Anchor Organizations

- **Healthcare/Telemedicine**
Monday, June 7, 2021 | 11:00 am - 12:00 pm
- **Veteran/Active Military**
Wednesday, June 2, 2021 | 10:00 am - 11:00 am
- **Business**
Thursday, June 3, 2021 | 11:00 am - 12:00 pm
- **Civic Engagement/Justice System**
Friday, June 18, 2021 | 11:00 am - 12:00 pm
- **Individuals with Disabilities**
Town Hall Thursday, June 24, 2021 | Pending final details
- **Seniors (OATS/Senior Planet/AARP)**
Tele Town/Hall Tuesday, July 6, 2021 (+Social Media)
- **Funders**

Community Outreach | Participation

	Organization Name	Survey	One-on-One	Focus Group	Advisory
1	Adult Years Program	Yes			
2	Adult Youth Vocational Program	Yes			
3	Alamo Colleges District	Yes	Yes		
4	American GI Forum	Yes			
5	American Indians in Texas at the Spanish Colonial Missions	Yes		Yes	
6	Any Baby Can of San Antonio	Yes			
7	Archdiocese of San Antonio		Yes		
8	Artpace San Antonio	Yes			
9	Autism Treatment Center	Yes			
10	Avenida Guadalupe Association	Yes			
11	AYVP	Yes			
12	Bexar County		Yes		
13	Bexar County Commissioners Court (Community Outreach & Engagement)	Yes			
14	Bexar County Education Coalition		Yes		
15	Bexar County Health Collaborative			Yes	
16	Bibliotech		Yes		
17	Big Brothers Big Sisters of South Texas	Yes			
18	Bridges to Care - San Antonio	Yes			
19	Brooks Development Authority		Yes		Yes
20	Centro Cultural Aztlan, Inc.	Yes			
21	Cesar E. Chavez Foundation			Yes	
22	ChildSafe	Yes			
23	City Education Partners	Yes	Yes		Yes
24	City of San Antonio		Yes		Yes
25	City of San Antonio Economic Development Department	Yes			
26	Classical Music Institute	Yes			
27	Community First Health Plans	Yes			
28	Conjunto Heritage Taller	Yes			

Community Outreach | Participation

	Organization Name	Survey	One-on-One	Focus Group	Advisory
29	COPS/Metro	Yes	Yes		
30	COSA Office of Veteran Affairs		Yes	Yes	Yes
31	disABILITYsa	Yes	Yes	Yes	
32	Ella Austin Community Center	Yes			
33	ESC 20*		Yes		Yes
34	Esperanza Peace and Justice Center	Yes			
35	Essence Prep	Yes	Yes		
36	Family Service Association of San Antonio, Inc.	Yes			
37	Family Violence Prevention Services, Inc./The Battered Women and Children's Shelter	Yes			
38	Geekdom		Yes		
39	Girls Inc. of San Antonio	Yes			
40	Good Samaritan Community Services	Yes			
41	Goodwill				Yes
42	Habitat for Humanity of SA	Yes			
43	Healthy Futures of Texas	Yes			
44	Hemisfair	Yes			
45	House of Neighborly Service	Yes			
46	Individuals and Families Impact Council, United Way of Bexar County	Yes			
47	Intercultural Development Research Association	Yes	Yes		Yes
48	Launch SA	Yes			
49	Libraries Without Borders US	Yes			
50	Lift Fund - Women's Business Center WBC-SA			Yes	
51	Lit Communities		Yes		
52	LISC San Antonio	Yes			
53	Louis Escareno Attorney at Law			Yes	
54	Madonna Center, Inc.	Yes			
55	Martinez Street Women's Shelter	Yes			Yes
56	Meals on Wheels San Antonio	Yes			
57	Methodist Healthcare Ministries	Yes	Yes	Yes	Yes

Community Outreach | Participation

	Organization Name	Survey	One-on-One	Focus Group	Advisory
58	Mexican American Civil Rights Institute	Yes			
59	MICRO:SA	Yes			
60	MY Charity	Yes			
61	National Hispanic Institute San Antonio	Yes			
62	North San Antonio Chamber of Commerce	Yes			
63	OATS/Senior Planet		Yes	Yes	Yes
64	Orangetheory Fitness Huebner	Yes			
65	Project QUEST, Inc.	Yes			
66	Project Search/Children's Hospital of San Antonio	Yes			
67	Project Transformation Rio Texas	Yes			
68	Prosper West San Antonio	Yes		Yes	
69	Respite Care of San Antonio	Yes			
70	Restore Education	Yes			
71	Rise Recovery	Yes		Yes	
72	Roy Maas Youth Alternatives	Yes			
73	SA Youth	Yes			
74	SAGE		Yes	Yes	
75	San Antonio Independent School District*	Yes	Yes		Yes
76	SAISD Adult Years Vocational Program	Yes			
77	SAISD/AYVP/ Project SEARCH	Yes			
78	SAMSAT -- San Antonio Museum of Science and Technology	Yes			
79	San Anto Cultural Arts	Yes			
80	San Antonio Clubhouse	Yes			
81	San Antonio Economic Development Foundation		Yes		Yes
82	San Antonio Housing Authority		Yes		
83	San Antonio Library Foundation		Yes		
84	San Antonio Public Library		Yes		
85	SAY Sí	Yes			

Community Outreach | Participation

	Organization Name	Survey	One-on-One	Focus Group	Advisory
86	Social and Health Research Center, Inc.	Yes			
87	Soldiers' Angels	Yes		Yes	
88	Southside First Economic Development Council	Yes	Yes		
89	Southwind Fields	Yes			
90	St. Mary's University Upward Bound Grant	Yes			
91	Steven A. Cohen Military Family Clinic at Endeavors in San Antonio	Yes		Yes	
92	Students of Service (SOS)	Yes			
93	Successful Aging and Living in San Antonio (SAAF)	Yes			
94	TechBloc		Yes		
95	Texas A&M San Antonio		Yes		Yes
96	Texas Veterans Network (AACOG)	Yes		Yes	
97	The Arc of San Antonio	Yes			
98	The Children's Bereavement Center Of South Texas	Yes			
99	THRU Project	Yes			
100	Toyota Motor North America	Yes	Yes		Yes
101	Trinity University - Center for Innovation and Entrepreneurship	Yes	Yes		
102	TRIO Upward Bound- Palo Alto College	Yes			
103	University Health	Yes		Yes	Yes
104	UP Partnership	Yes			
105	Upward Bound, Trinity University, Harlandale and Edgewood ISD	Yes			
106	UT Health San Antonio	Yes			
107	UTSA Small Business Development Center			Yes	
108	VIA Metropolitan Transit	Yes	Yes		
109	Voices for Children of San Antonio	Yes			
110	Webhead	Yes			
111	YMCA of Greater San Antonio	Yes			
112	Youth Code Jam	Yes			
113	YWCA San Antonio	Yes			

Community Outreach | Participation

	School District/Charter/Organization Name (K-12)	Questionnaire	Focus Group
114	Alamo Heights ISD	Yes	Yes
115	Boerne ISD		Yes
116	Brooks Academy of Science and Engineering	Yes	Yes
117	East Central ISD		Yes
118	Edgewood ISD		Yes
119	Eleanor Kolitz Hebrew Lang. Academy	Yes	
120	Ft. Sam Houston	Yes	Yes
121	Grow Associates, LLC		Yes
122	Harlandale ISD	Yes	Yes
123	Jubilee Academy		Yes
124	Judson ISD		Yes
125	Lackland ISD		Yes
126	Lighthouse Charter School		Yes
127	New Frontiers		Yes
128	Northeast ISD	Yes	Yes
129	Northside ISD		Yes
130	Promesa Academy	Yes	
131	Responsive Ed		Yes
132	SA Prep		Yes
133	San Antonio ISD		Yes
134	Schertz Cibolo Universal City ISD		Yes
135	School of Science and Technology		Yes
136	Seguin ISD		Yes
137	Southside	Yes	
138	Somerset ISD		Yes
139	South San Antonio ISD		Yes
140	Southwest ISD		Yes
141	TEA		Yes

Interview findings

Preliminary interview findings | Learnings from current state point to a set of forward-looking priorities for the digital equity plan

Current state



Many efforts are underway in pockets (e.g., Connected Beyond the Classroom, BiblioTech pilot, etc.) but with **limited coordination**, creating **duplicative work** and **gaps** of unmet need

Some areas still **lack adequate broadband infrastructure** due to redlining, outdated copper wire, poor housing structures, and **substandard internet service quality**

Lack of education and comfort (e.g., language barriers, fear of damaging devices, etc.) around digital tools has been a consistent barrier, slowing the progress of current efforts

Measuring progress of recent initiatives and **communicating the need** for digital inclusion has been limited by a lack of compelling metrics to demonstrate value proposition

We have a unique moment to have an impact given federal money on the horizon (e.g., ARPA, infrastructure bill, etc.) as well as the upcoming Texas broadband planning efforts

Forward-looking priorities



- Develop a **shared fact-base** through regular information sharing / touchpoints in order to participate in **coordinated action** on shared initiatives
- Take a **'puzzle' approach to infrastructure**, with tailored and different solutions for specific areas / pops and **multiple time horizons** (e.g., a 3-year and 5-year plan)
- Build a robust support network to **offer 1:1 guidance**, **enable digital skills building** (e.g., BiblioTech / SAHA digital course credits, Texas A&M SA help desk / digital scholars' program)
- Assess the **ROI / community and economic impact of digital inclusion efforts** (e.g., digital as foundational to workforce dev.) and align on a set of shared KPIs to track progress
- Prepare **'shovel ready' projects** and **identify accountability to maximize funding** across sources (bonds, grants, CRA bank loans, etc.)

Lesson learned from current state and efforts underway

There's a lot going on, but limited coordination

- *"There's so much going on. We ran a survey back in April, but that's already almost a year old. We need to do a better job on outreach to know what demographics are served and how"*
- *We should know what groups are doing similar work to know where we're duplicating efforts and where gaps exist....there's too much competition for funding stemming from not being aligned"*

Some families lack access to infrastructure and service quality

- *"Some neighborhoods are still dealing with copper wire, meaning that if it rains they lose internet"*
- *"Lack of adequate housing compounds access problems. Some roofs are so short you can't even put a booster on the house. Others are covered by tree canopies that block signal from reaching the home"*
- *"There's no shared definition of what basic service even means, so ISPs can claim coverage, but the quality of service isn't there"*
- *"Texas is at disadvantage because they don't have the same level of competition among ISPs relative to other states...AT&T has been particularly unwilling to engage"*
- *"Even though the city owns COSANet, legally they can't unlock its potential since the law prevents them from stepping in unless there's a dearth of providers, which isn't the case for San Antonio"*

Insufficient education and comfort around digital are key challenges

- *"A lot of kids are being raised by their grandparents, who often don't speak much or any English and have limited digital knowledge"*
- *"Many people are so afraid of breaking the devices we give them that they don't use them at all"*
- *"To even qualify for many assistance programs, participants are required to present ID, social Security, credit checks...it's almost as if the intent is to prevent people from signing up"*
- *"Some people have privacy concerns and don't feel comfortable with devices installed in their homes collecting data on them"*

Identified forward-looking priorities

Develop a shared fact-base

- "We need a clearing house of data to make sure everyone involved is looking at the same facts; ideally, it would be online for the larger public to access"

Take a 'puzzle' approach to infrastructure

- "The goal is long term adoption, not temporary solutions like EBB; successfully building the puzzles requires stronger coordination across city, county, and philanthropy"
- "Ultimately, we need a 'swiss army knife approach'... Private networks and hotspots are useful but imperfect. I hope in 5 years we turn off these solutions for better direct-to-home, high quality fiber"
- "There's a long-term model where new providers step in to develop networks for school and get to use those same networks to offer other services, like healthcare providers doing telehealth"

Build a robust support network to offer 1:1 guidance

- "1:1 counseling for students, adults, and seniors go a long way in getting people online. You need a dedicated staff to meet the need, around 1:100 counselors to users, not the current 1:300"
- "[Texas A&M] developed a technical support help desk that doubles as a digital scholarship program that has students mentor other students to learn digital skills"
- "We have a program where students can enroll in digital literacy courses, in which they can earn a free laptop or desktop computer upon successful completion of the curriculum"

Assess the ROI / economic impact of digital inclusion efforts

- "We need metrics around money and return on investment in order to clearly communicate the value of digital inclusion to potential funders / other interested parties"
- "[Texas A&M SA] is creating consistent metrics which can be used to demonstrate quantitative impact"

Prepare 'shovel ready' projects / maximize funding

- "We're need our initiatives to be shovel-ready to apply for federal grants...we need to know where to use federal funding versus where to apply for a 10K CRA Bank grant"
- "Additional pilot programs might be needed to qualify for additional grants and demonstrate impact"

Stakeholder and community engagement is a key enabler of success

Engage ISPs in a productive way

- "Discussions with providers should be *friendly and constructive*, focusing on how ISPs can help rather than being an obstruction to the process"
- "There doesn't have to be a winner or loser [between city and ISPs] ...We can make this work with a reasonable rate of return for ISPs but they're still focused on maximizing the rate of return"
- "The city did RFP of ISPs to see if they had better deals for low-income communities; *none of them came up with anything close to the costs we're getting with private wireless model*"

Invest in building a strong coalition

- "The [Dallas] coalition has been a critical component to success and driving progress; *convening bi-weekly to has been useful for community groups to share information and express concerns /needs*"
- "For a long time, the city [of San Antonio] has been trying to everything on its own. That's not going to be how we solve this problem. *It's going to take collaboration, coordination, and partnership*"

Build relationships and deepen trust with community

- "So much of the work we've done in Dallas has been enabled by *high trust and social capital* we've cultivated by *engaging deeply with the community and building relationships*"
- "Our plan and messaging has to be *inclusive of all* the diverse sections of our community... we need to leverage '*trust messengers*' - organizations that already have high degree of trust in communities"

Ensure community involvement in solution

- "When you build programs or solutions *for* people instead of *with* them, it's harder to get them on board with whatever it is you're offering them"
- "*Building relationships with community members comes before telling them what you can do for them; this happens informally through repeated interactions*"

Table of contents

3	Fact-base
4	Summary
6	Interviews and Community Engagement
19	Inventory Survey
28	K-12 Questionnaire
33	Size and Nature of the Digital Divide
47	ISP Economics & Engagement
56	Initiative Details
57	Infrastructure
93	Affordable Housing Access
104	Education Sponsored
127	Low-income Internet
149	Device Support
162	Adoption Support
191	Data & Analytics
214	Operating Model
244	Population Segments
250	Implementation Roadmap
273	Funding Databases
290	Asset Maps
291	Access Maps
294	Coverage Maps
300	Community Level Maps

99 organizations surveyed serve a wide range of populations

survey respondents

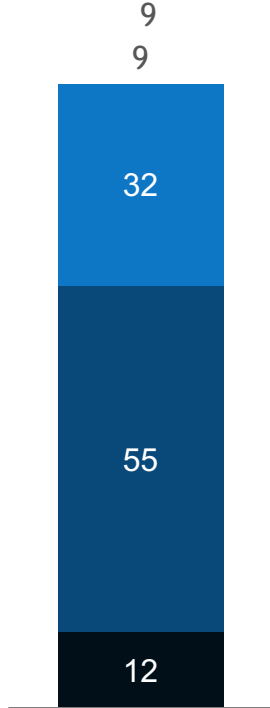

of organizations serving specific populations

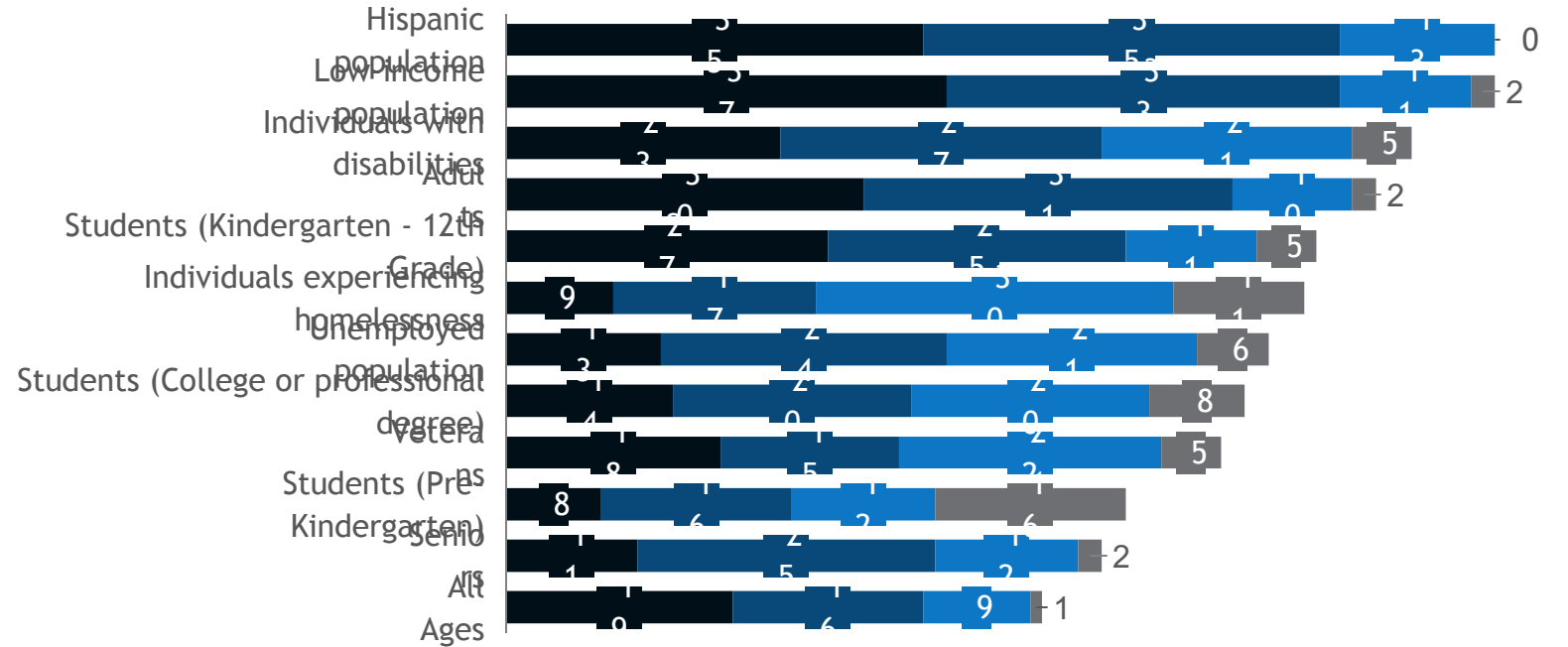

The organizations offer a variety of social services, many of which rely on recipients having internet access

of organizations offering social services



Does your organization rely on residents having internet access and/or device to use some of your services?

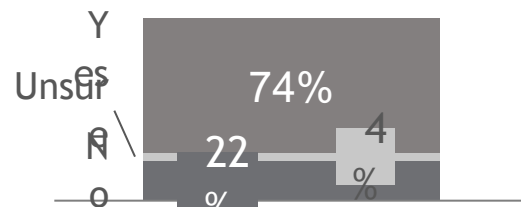

Please provide details on how having access to the internet and/or devices helps residents use your services?

- “ During the pandemic, some of our **economic empowerment and financial literacy courses were hosted remotely**. Same for our youth programming, racial justice and gender equity programming - *YWCA San Antonio*
- “ Many services, or information about said services, are online. Offline resources exist as well, but **may be difficult to access or require separate infrastructure to access** - *Bexar County Commissioners Court*
- “ They are able to **connect via Wi-Fi when on our campus and also have access to a small computer lab**. All of our programs for all ages are dependent on access to the internet for program delivery and reporting of data - *Good Samaritan Community Services*
- “ They are better able to **apply for jobs, conduct research, communicate and stay engaged, and complete online applications** for other programs - *Prosper West San Antonio*

More than 80 organizations offer a variety of digital inclusion services

of organizations offering digital inclusion services

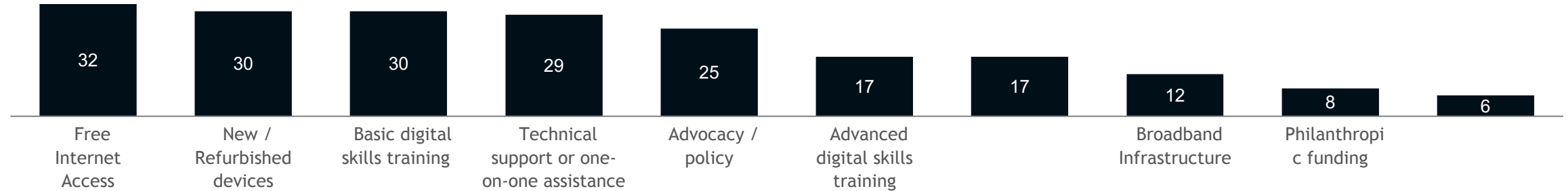

Why does your organization offer and invest in digital inclusion efforts?

- “ It improves **quality of life** for San Antonio area residents and contributes positively to the business climate-San Antonio Chamber of Commerce
- “ It is crucial for inclusion of the disabilities population-Southwind Fields
- “ There is a clear, **geographical digital divide** in San Antonio that needs to be addressed-Libraries Without Borders
- “ Consistent digital connectivity is critical to **help youth and their families access services, education, employment.**-Girls Inc. of San Antonio
- “ The poverty rate in this MSA is the highest in the country. Our students & prospective students need technology to put them on an even playing field. Education can drive social mobility but we need to equip our students for success. **There is no “productivity” without “connectivity”** -Alamo Colleges District
- “ Broadband/digital inclusion impact on **health equity and breaking the cycle of poverty.** As our VP, J Barton, has noted, Digital Inclusion is economic inclusion-Methodist Healthcare Ministries

Funding for digital inclusion services comes mainly from existing budget, federal funding, and philanthropy

Organizations rely on different funding sources...

What have been your funding sources for digital inclusion efforts?

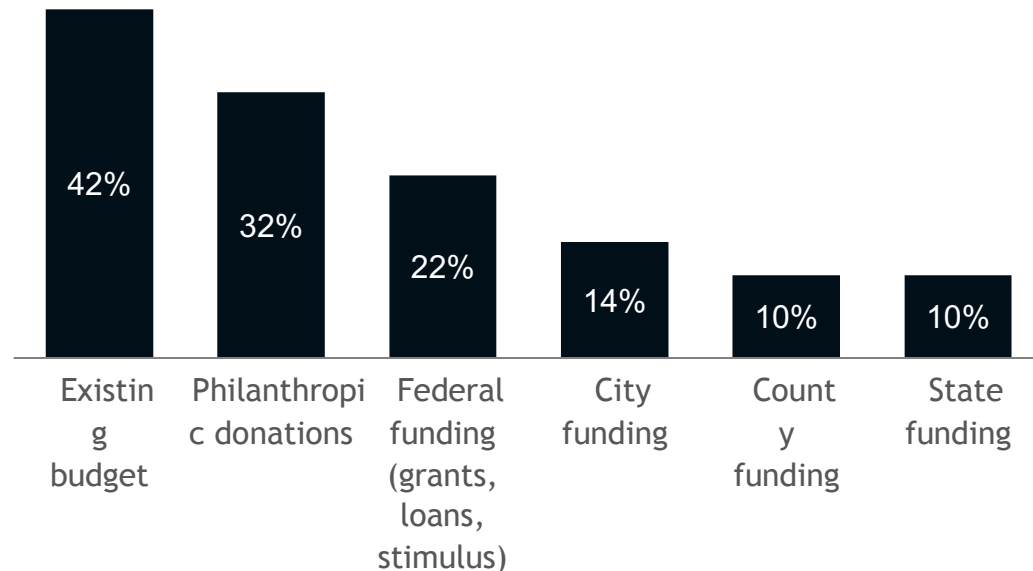

... and would expand if additional funding were available

Please share additional details on efforts your organizations would be interested in pursuing if additional funding were made available

- “ Provide more **internet to individual homes** with stipends to get unlimited data hotspots, [...] new devices and more staff to focus on training and support - *San Antonio Housing Authority*
- “ Providing **telehealth therapy to children with autism** who do not have access to in-person therapy because they are located in a rural area or do not have transportation - *Autism Treatment Center*
- “ Smartphones or tablets for current/former foster youth to provide them **connection to vital resources that prevent homelessness, incarceration and victimization** - *THRU Project*
- “ **Equitable digital literacy courses** for teachers and families - *Intercultural Development Research Association*
- “ Increase both **software and hardware capabilities** to assist a greater number of underserved - *Ella Austin Community Center*

Both organizations and recipients face barriers to digital inclusion

Recipients face barriers to utilizing services

% of organizations whose recipients face a barrier preventing them from fully utilizing the service the organization offers

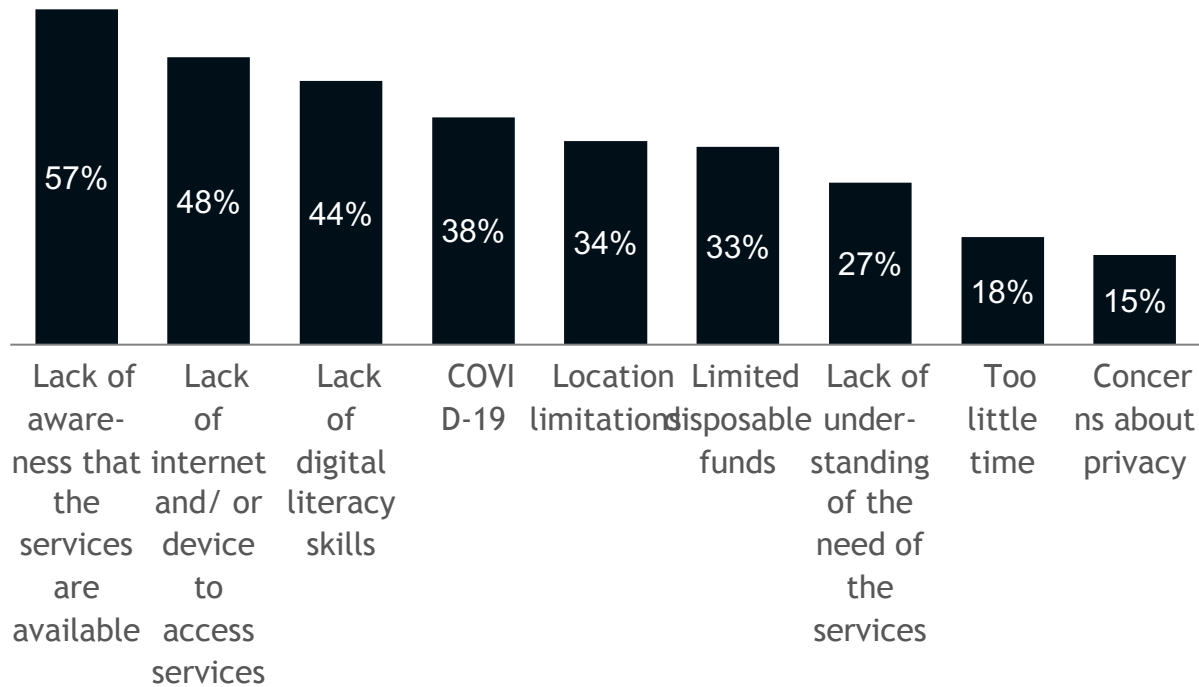

Organizations face barriers to offering services

% of organizations that face a challenge in offering their services

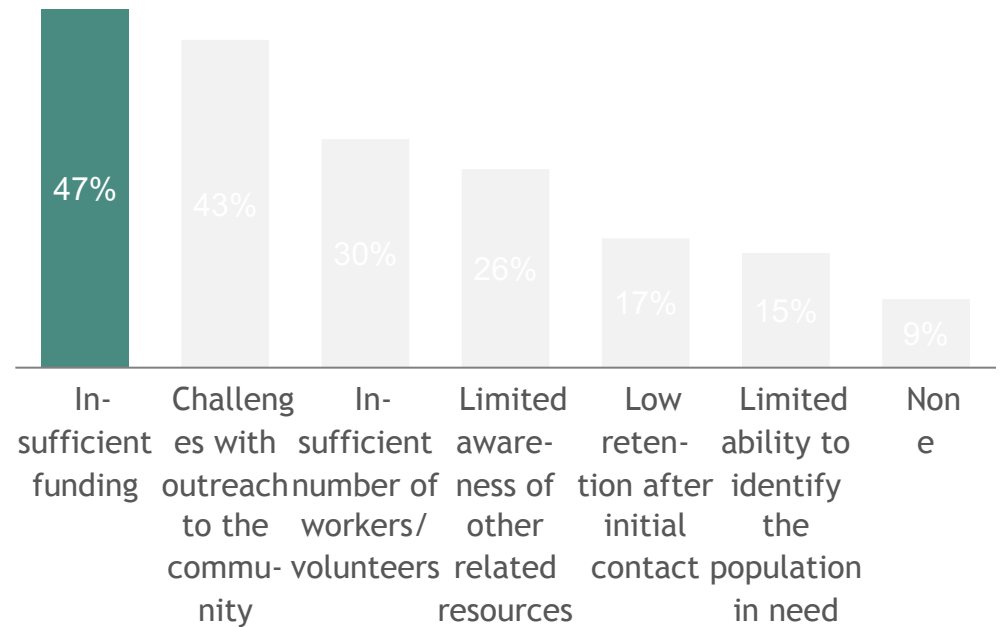

Source: survey of businesses and organizations in San Antonio (n=99)

Support services can help remove some of these barriers

% of organizations that believe a support service would make them better equipped to offer digital inclusion services

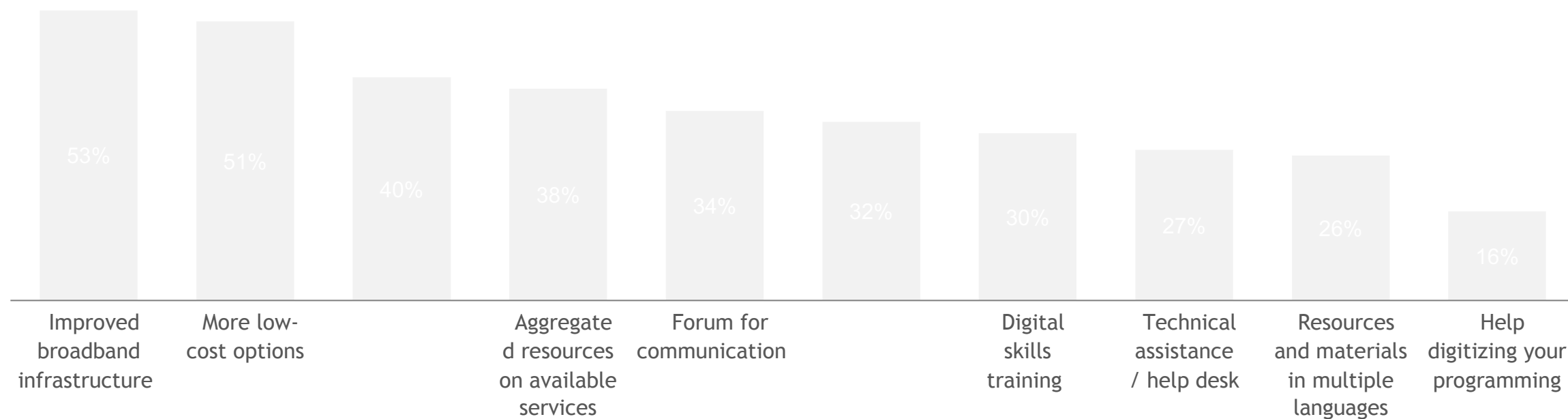

COVID-19 raised the urgency to provide digital services even post-pandemic

Almost 70% of organizations started or expanded their digital inclusion efforts during the pandemic

% of organizations that provided services or support before the pandemic

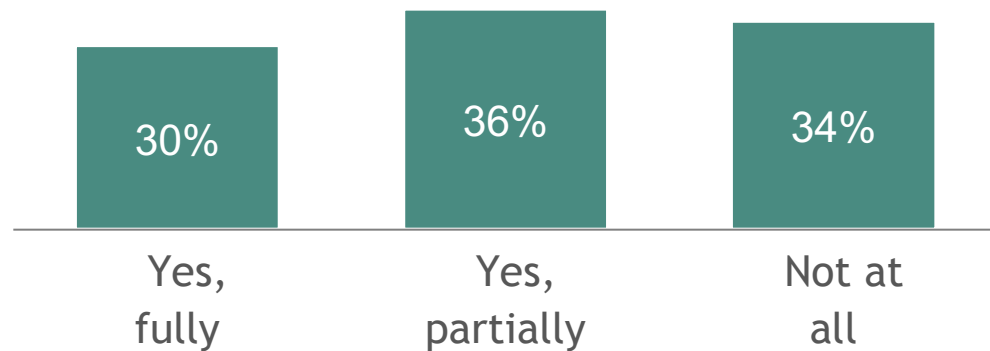

More than 90% of these organizations plan to maintain these services in some capacity post-pandemic

% of organizations that plan to continue services or support after the pandemic

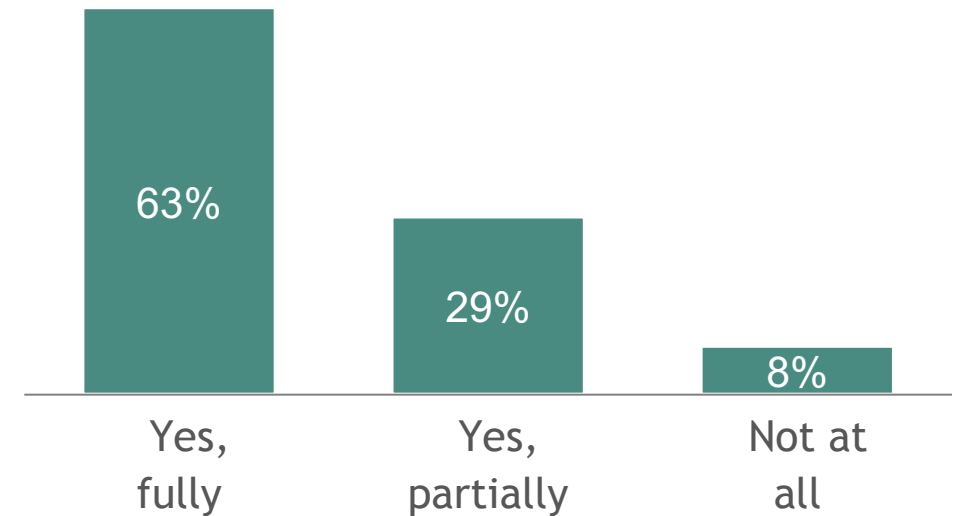

Next steps

Continue to refine fact-base and digital equity plan based on findings from inventory survey

Build out directory (map and table) of community resources, to be made available on public portal

Maintain live inventory survey to collect updated responses and information on an ongoing basis

Table of contents

3	Fact-base
4	Summary
6	Interviews and Community Engagement
19	Inventory Survey
28	K-12 Questionnaire
33	Size and Nature of the Digital Divide
47	ISP Economics & Engagement
56	Initiative Details
57	Infrastructure
93	Affordable Housing Access
104	Education Sponsored
127	Low-income Internet
149	Device Support
162	Adoption Support
191	Data & Analytics
214	Operating Model
244	Population Segments
250	Implementation Roadmap
273	Funding Databases
290	Asset Maps
291	Access Maps
294	Coverage Maps
300	Community Level Maps

Several initiatives pursued to address the broadband internet and device needs of their students



Broadband Internet

- **Hotspot distribution for at-home internet**, some with no data caps
- **Public access Wi-Fi** (e.g., parking lots, parks, school premises)



Devices

- **Chromebook / tablet** lending for use away from school
- **1:1 student to device ratio** in nearly all schools



Digital Literacy

- **Hotlines** for tech support
- Video **digital tutorials** for parents and students
- **Professional development sessions** with parents and staff

Preliminary

Device and connectivity solutions have varied across Bexar County ISDs



Northeast	64,215	Unknown		✓	Unknown	✓	✓	State / Federal grants
Harlandale	12,444	40%		✓	90%	✓	✓	ESSER, E-Rate, State / Federal grants
Southside	5,000	30%	✓	✓	15%	✓		ESSER, State / Federal grants
Alamo Heights	4,917	2%		✓	1%	✓		Philanthropy, School budget
Brooks Academy	3,043	26%	✓	✓	72%	✓		Philanthropy, State / Federal grants
Ft. Sam Houston	1,667	0.3%		✓	0%			School budget
Eleanor Kolitz Hebrew Lang. Academy	467	2%		✓	2%	✓		E-Rate, Philanthropy
Promesa Academy	180	17%		✓	89%		✓	School budget

Key learnings from school connectivity and device distribution efforts

While there have been many learnings and successes....

- “ *"The pandemic created a sense of urgency around getting students connected and got a lot of buy-in"*
- "We're really proud of having gotten to 1:1 devices for all out students"*
- "Teachers have responded well to being pushed out of their comfort zone and adapting to the situation"*
- "A lot of students have thrived under remote learning. We're hoping to keep offering that going forward"*

...There have also been challenges

- “ *"Getting devices back at the end of the year has been an ongoing issue"*
- "The loss rate for devices is much higher than usual, from 5% to 20%"*
- "Offering 24/7 tech support to students and parents through the hotline has really strained our staff"*
- "We still don't have bilingual tech support for families, which might be leaving some people out"*

Identified areas for continued support



Additional devices to account for high loss rate



Centralized device management



Better data on student need (i.e., who needs access, where they are)



Additional staffing to support bilingual tech and digital literacy support

Areas for ongoing K-12 investment in digital

- 1 Maintaining digital curriculums
- 2 Exploring remote / in-person hybrid models
- 3 Planning more robust technology training sessions

Table of contents

3	Fact-base
4	Summary
6	Interviews and Community Engagement
19	Inventory Survey
28	K-12 Questionnaire
33	Size and Nature of the Digital Divide
47	ISP Economics & Engagement
56	Initiative Details
57	Infrastructure
93	Affordable Housing Access
104	Education Sponsored
127	Low-income Internet
149	Device Support
162	Adoption Support
191	Data & Analytics
214	Operating Model
244	Population Segments
250	Implementation Roadmap
273	Funding Databases
290	Asset Maps
291	Access Maps
294	Coverage Maps
300	Community Level Maps

Overarching context | Bexar County is geographically, economically and racially/ethnically diverse, requiring a multi-faceted approach to broadband

Geographically diverse



- Dense urban core with multi-unit buildings
- Rural periphery with low pop. density and single-unit homes



Infrastructure solutions must vary based on topography, assets

Economically diverse

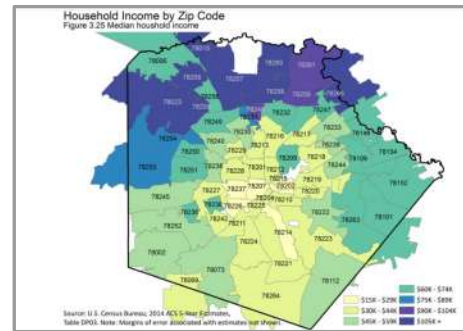

Recall | San Antonio and Bexar residents face a significant digital divide ...



20% (390K) of San Antonio/Bexar residents lack access to broadband



... with significant differences across districts, e.g.,

- District 5: 38% lack access
- District 9: 6% lack access



10% (195K) of San Antonio/Bexar residents lack access to devices

... driven by several factors

Reasons for not using internet (% of respondents)

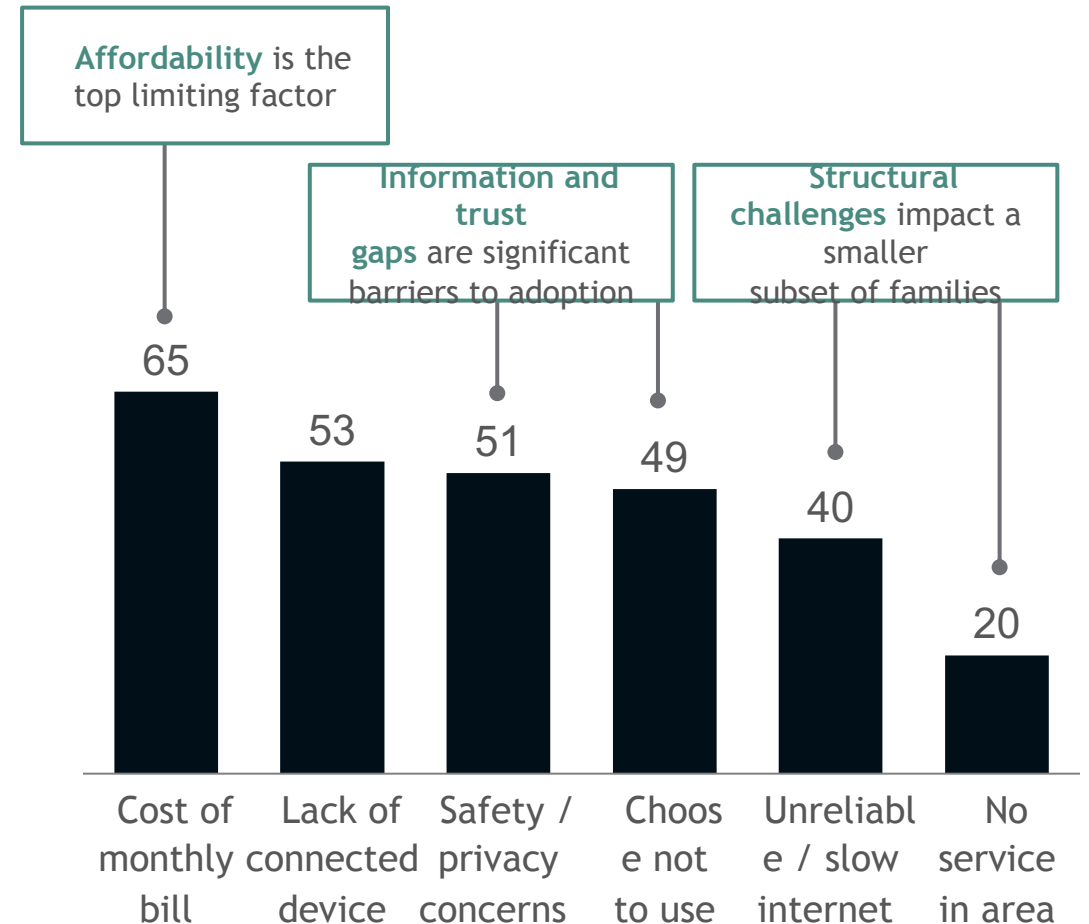

Affordability and adoption are the greatest barriers to access; extent of availability challenges varies by source and service quality

Category	Sources	# and % of households	Considerations
Availability: Unserved	Broadband Now	5K (0.8% of HHDs)	<ul style="list-style-type: none"> Unserved by 25 mbps coverage
	SASpeakUp ¹	27K (4% of HHDs)	<ul style="list-style-type: none"> Reported not having internet because there was no service in their area
Availability: Underserved	Broadband Now	9K (1.4% of HHDs)	<ul style="list-style-type: none"> Unserved by 100+ mbps coverage
	SASpeakUp	53K (8% of HHDs)	<ul style="list-style-type: none"> Reported not having internet because service was slow or unreliable
	Broadband Now	201K (30.1% of HHDs)	<ul style="list-style-type: none"> Unserved by 1 gig coverage
Affordability	SASpeakUp	87K (13% of HHDs)	<ul style="list-style-type: none"> Reported not having internet because could not afford the monthly bill
	ACS data	211K (33% of HHDs)	<ul style="list-style-type: none"> % with income less than \$50K, proxy income for hhd. of 4 eligible for the National School Lunch Program
Adoption	SA SpeakUp	67-100K (10-15% of HHDs)	<ul style="list-style-type: none"> Reported not having internet service because of data & privacy concerns or chose not to²

2. Survey asked if residents had access to the internet. 20% reported a lack of access. The survey then asked those without access "why". 1. 51% of respondents without access said they had security or privacy concerns; 49% of respondents without access said it was because they chose not to. Assumed 0-50% overlap

Low-income households and households with children represent almost 70% of the digital divide in Bexar County

No. of households without internet access in Bexar County

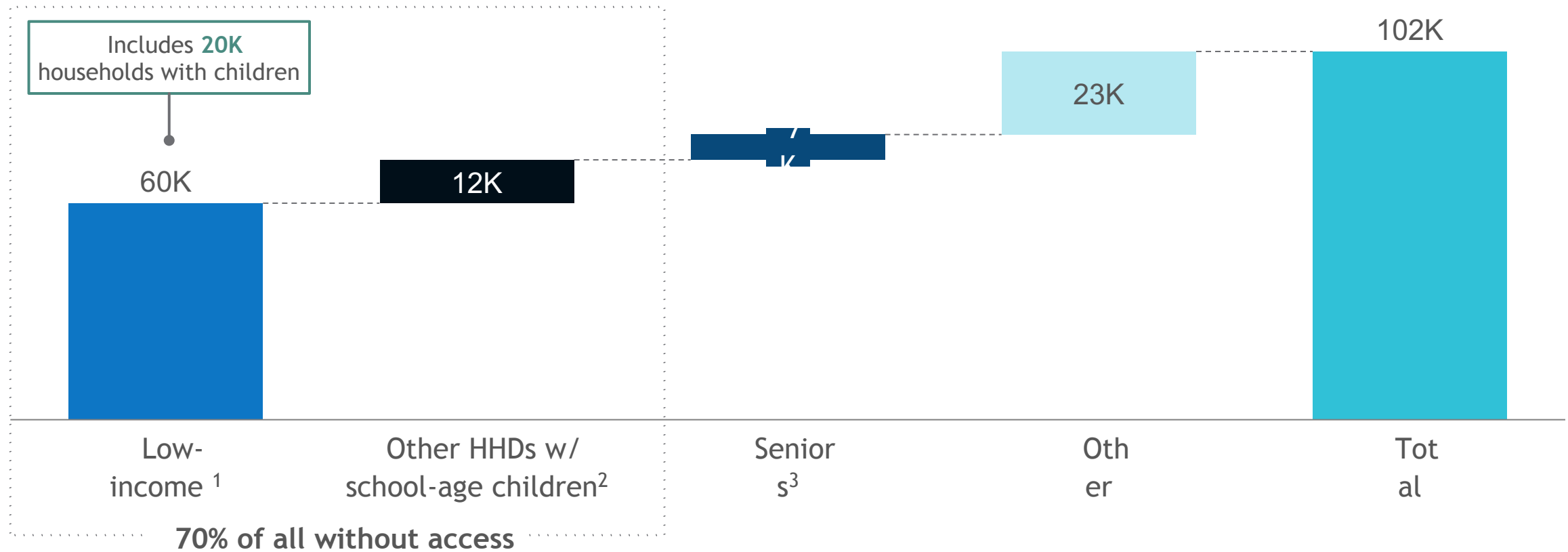

1. Low-income defined as households under \$50k in annual income 2. Excludes low-income families 3. Excludes low-income and families with children
 Source: ACS High-Speed Broadband Data for Bexar County (2019)

Income, Education and English proficiency level correlated with digital access

% with internet access by demographic in Bexar County

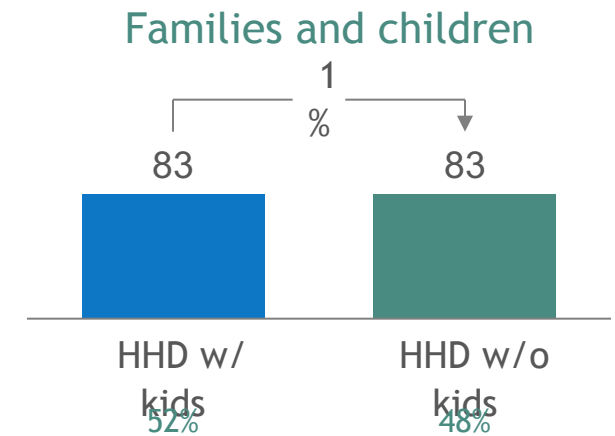
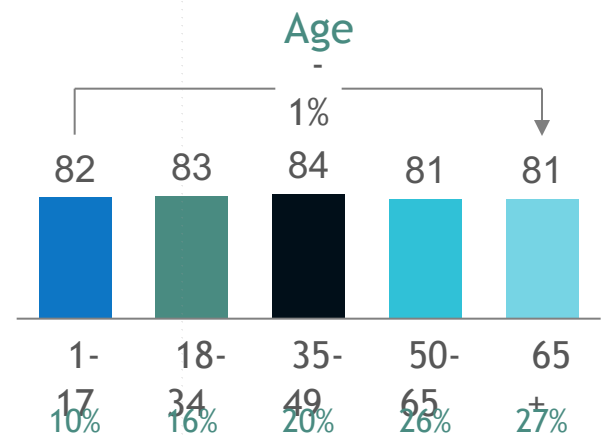
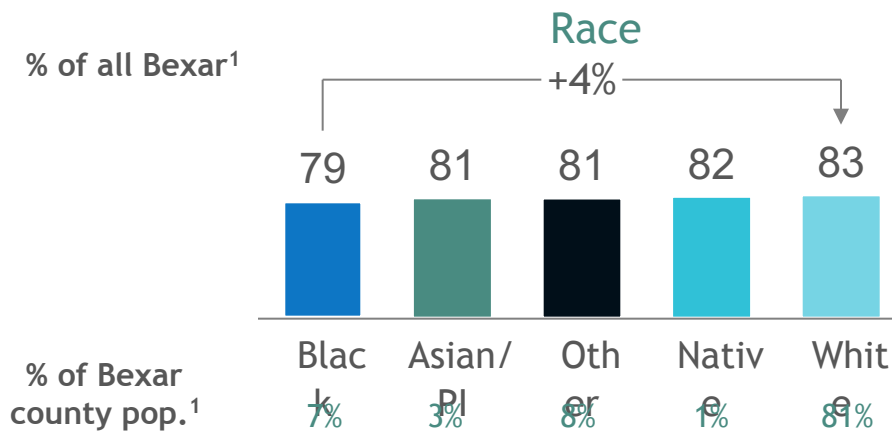
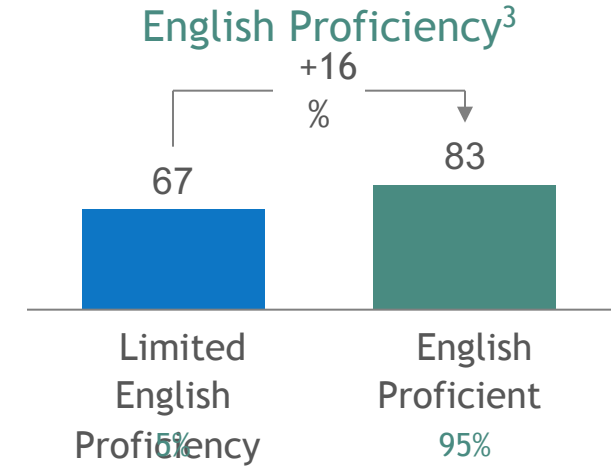
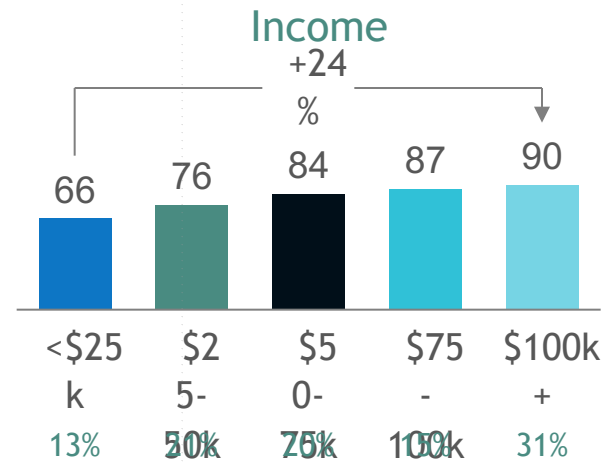
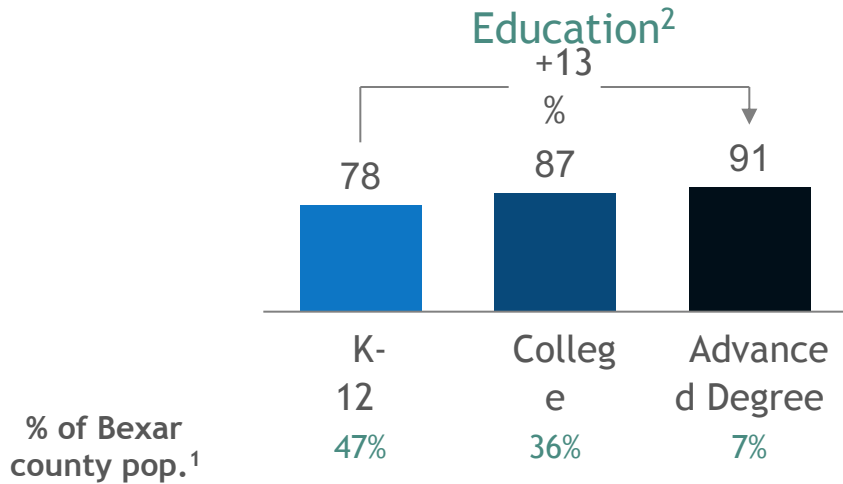

1. Excludes NA responses from total population count 2. Excludes pre-school age children and younger, resulting in less than 100% of total population. 3. Hispanic (60% of population) vs. Non-Hispanic (40% of population) follows a similar pattern, with 80% and 86% connection respectively
 Source: ACS High-Speed Broadband Data for Bexar County (2019)

Affordability is a main barrier to access for Bexar County students & families

- 65%** Residents that say affordability is main barrier to internet access
- \$60k** Income threshold at which digital skills gap shrinks
- \$54k** Median household income in Bexar county

Broadband access by income in San Antonio/Bexar (%)

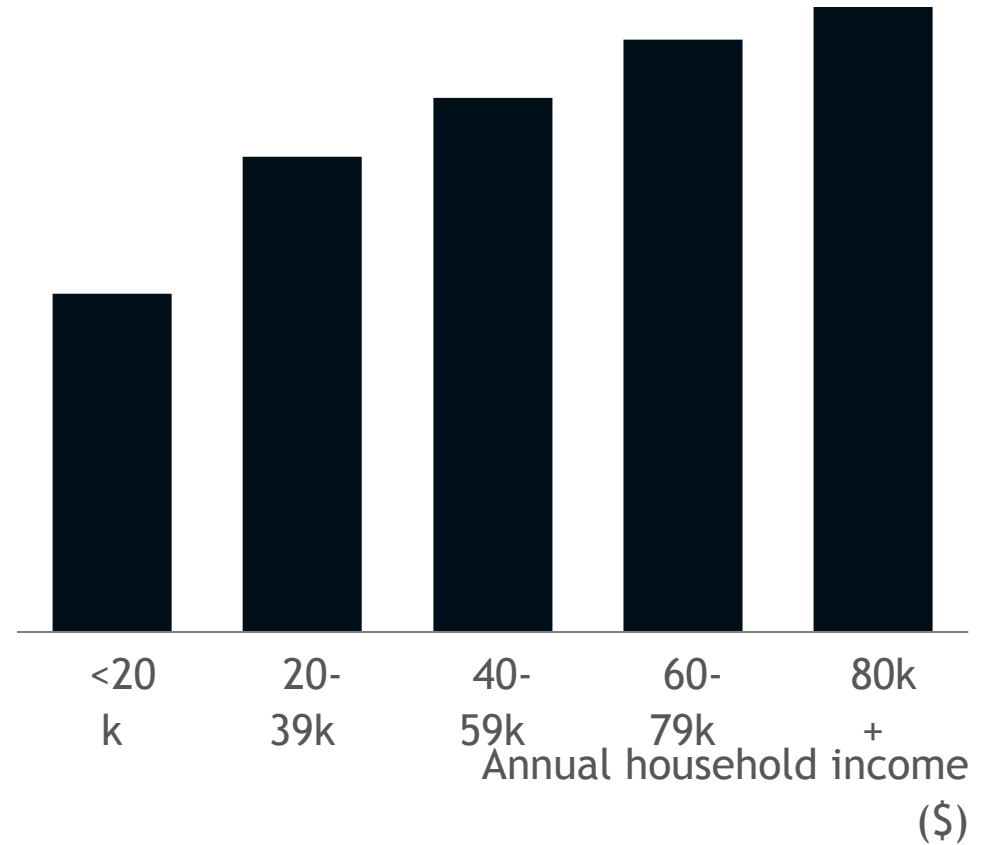

Adoption barriers significantly tied to preexisting socioeconomic challenges and patterns of exclusion

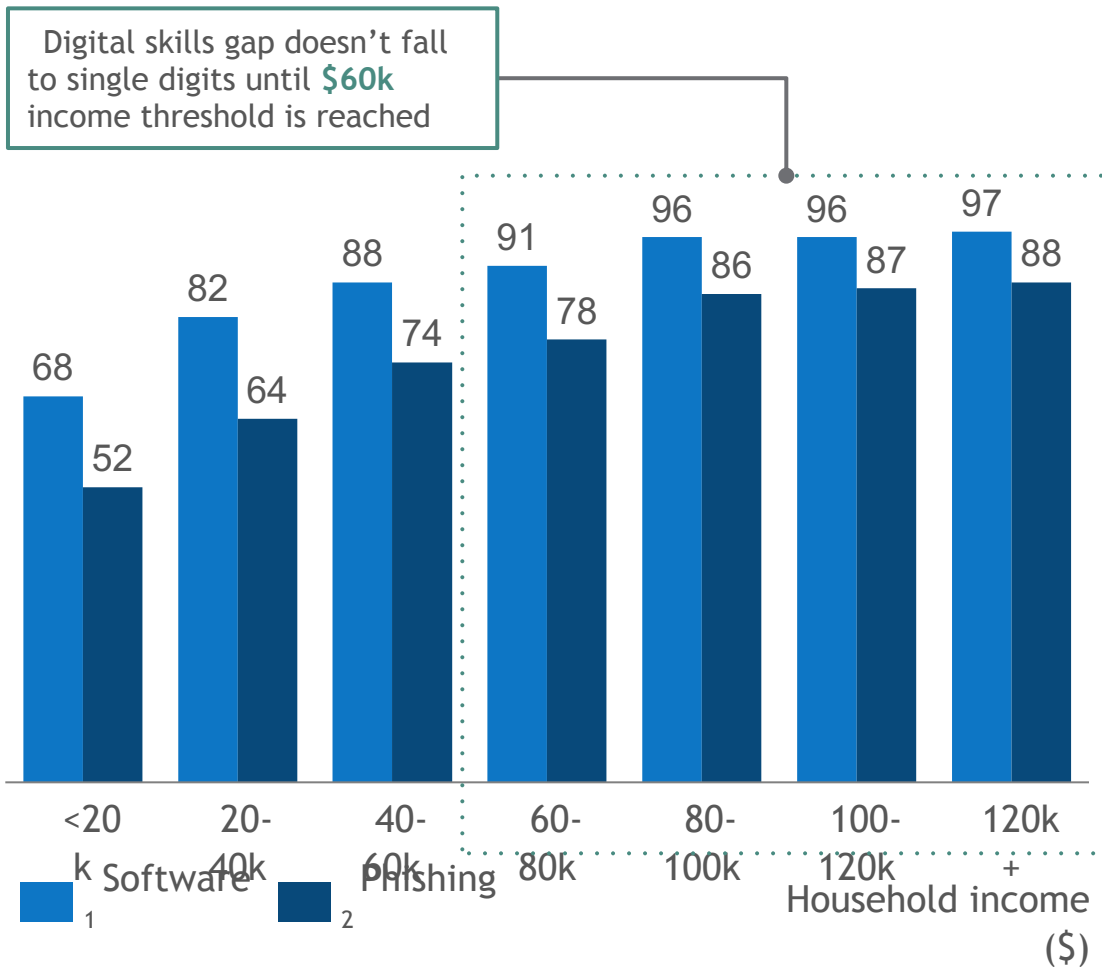

“[AT&T] is basically to the curb in every residence in San Antonio. But there’s a tremendous gap in digital literacy and understanding (how to use) broadband services. We are beginning to look at public education as a way of bridging the Digital Divide because it’s not necessarily infrastructure anymore. It’s costs and competition, which we have a great way of affecting, and it’s also digital literacy, which we have a desperate need to affect.”

- Ron Nirenberg,
Councilmember for San Antonio's 8th District

“[Lack of infrastructure] is not the problem at hand because high and low connectivity areas are less than 5 miles apart. Instead, the driver of this digital divide is the systematic social exclusion and structural oppression of marginalized communities left out in the past from opportunities and resources.”

- Digital Inclusion Survey and Assessment (2019)

1. Respondent proficiency regarding productivity software e.g. Microsoft Word, Excel, etc. 2. Respondents able to detect fraudulent emails collect personal information
Source: Institute for local Self-Reliance; San Antonio Report; Digital Inclusion Survey and Assessment (2019)

Benchmarks | Spread of broadband speed and prices are increasing, even as price for higher speed services falls

Broadband prices by download speed

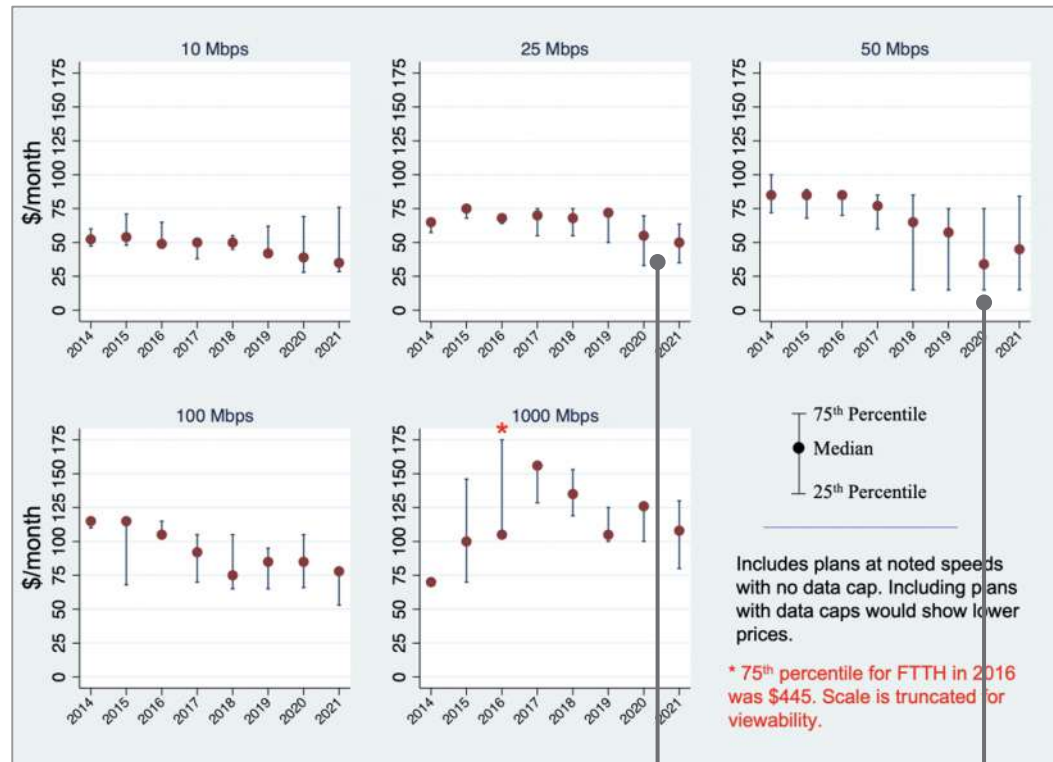

Spread of costs for a given service tier has grown

Cost of 50-100 mbps service have fallen faster than 10-25 mbps service

Price and speed of plans

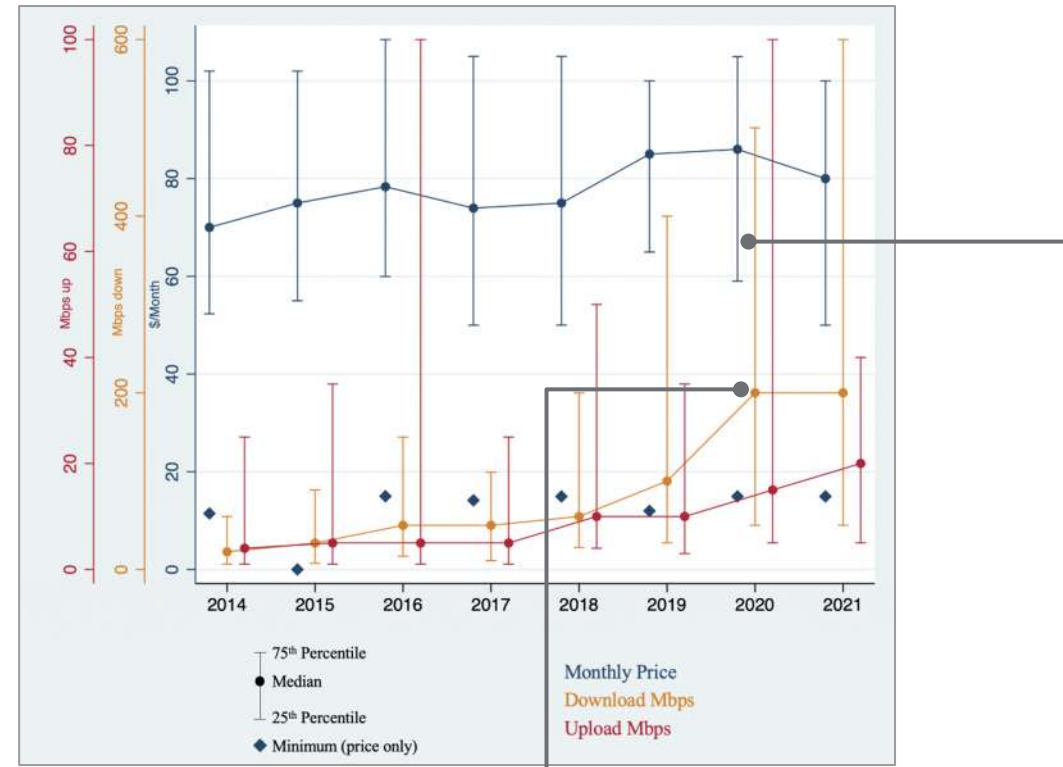

2020 saw the most significant increase in average speeds

The spread between min and max speeds have increased over time

Benchmarks | Other cities offer insight for pricing by speed tier

Speed (download/upload)	# of users	Service Offered	Provider / City	Cost	Implications for SA
12 mbps / 3mbps ¹ or less	1-2	Basic browsing and internet use; SD streaming on 1 device	Frontier (Long Beach)	\$29.99	<ul style="list-style-type: none"> Set county-wide min. speed threshold at either 25/3 or 50/5 Require all services 50/5 or slower to be <\$30/mo Target pricing for 100 / 10 to be \$45/mo Target pricing for 1 gig to be \$50/mo
			Viasat (Huntsville, Detroit, Detroit)	\$50	
25 mbps / 3 mbps	2-3 ¹	Gaming, Alexa; SD/HD streaming (quality varies based on number of devices)	Xfinity (Huntsville, Detroit)	\$25	
			Hughes Net (Huntsville, Detroit, Long Beach)	\$59.99	
50 mbps / 5 mbps	2-4	Gaming, Alexa; HD streaming on multiple devices	Comcast Internet Essentials (for low-income)	\$9.95	
100 mbps / 10 mbps	4+	HD streaming across multiple devices and smart home friendly	Wow! (Huntsville)	\$44.99	
			Spectrum (Long Beach)	\$49.99	
			AT&T (Huntsville, Detroit)	\$59.99	
1 Gbps (1000 mbps)	4+	HD streaming, smart home friendly; no data caps with extras (e.g., free storage)	AT&T (Long Beach)	\$49	
			Rocket Fiber (Detroit)	\$70	
			Google Fiber (Huntsville)	\$50-70	

1. Frontier service only for 6 mbps 2. Hughes Net claims capable for 2-4 devices; Xfinity claims capable for 1-2 devices
 Source: <https://nextcenturycities.org/wp-content/uploads/12.01.20-NCC-Case-Study-Huntsville-Final-1.pdf>; <https://nextcenturycities.org/wp-content/uploads/Detroit-Updated-12220.pdf>; <https://nextcenturycities.org/wp-content/uploads/12.16.20-NCC-Case-Study-Long-Beach-CA-FINAL.pdf>

Population density and income distribution

Population density

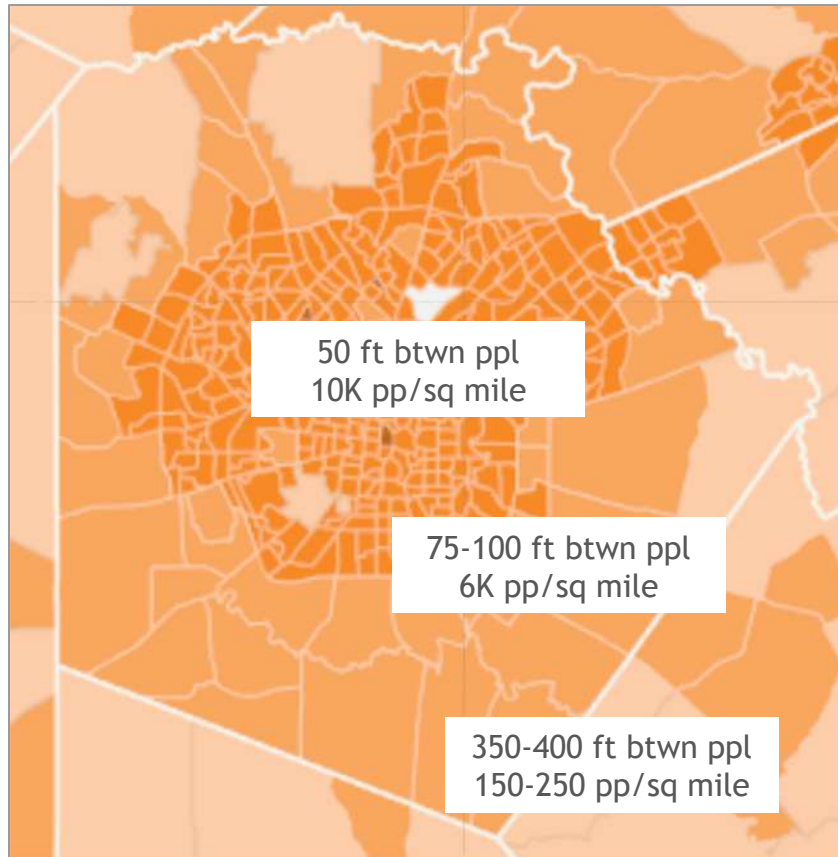

Income distribution

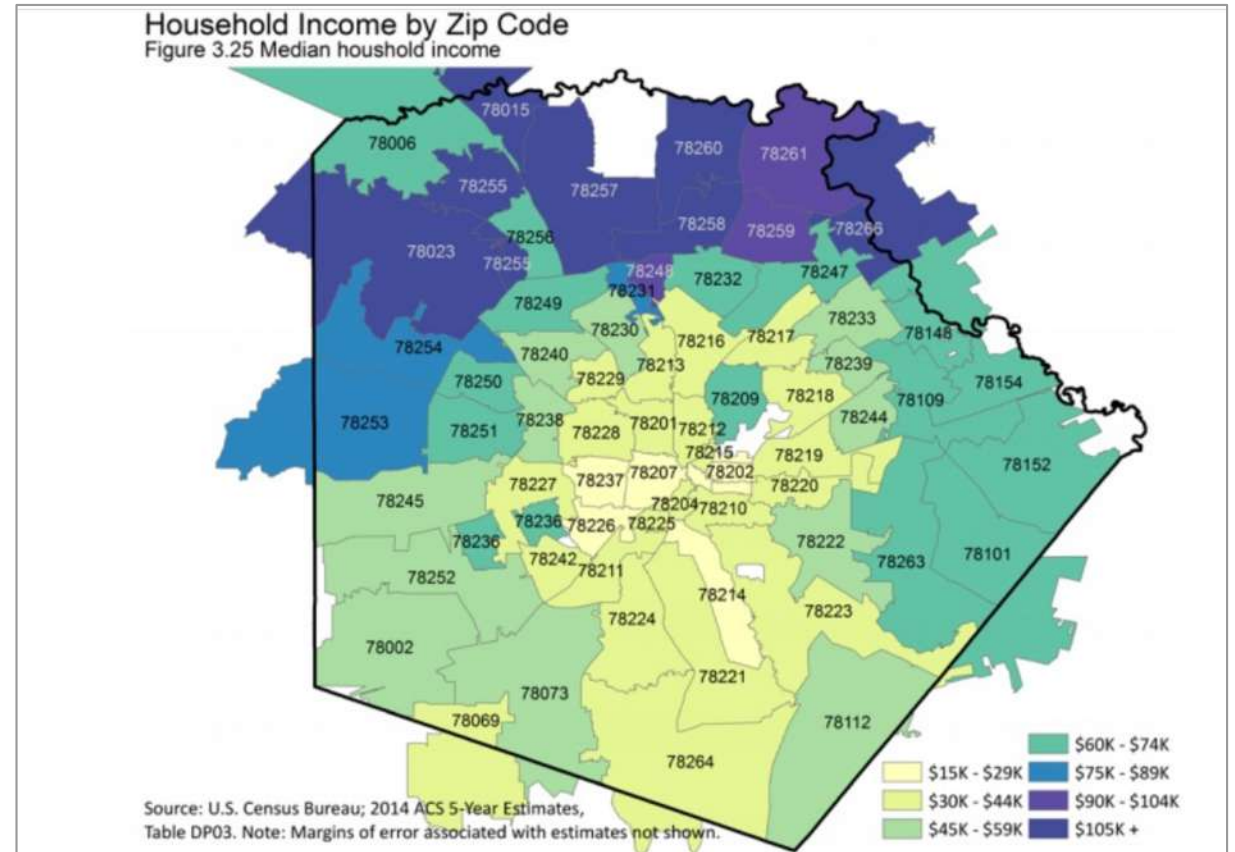

Broadband coverage mapping

DSL, Cable or Fiber Coverage

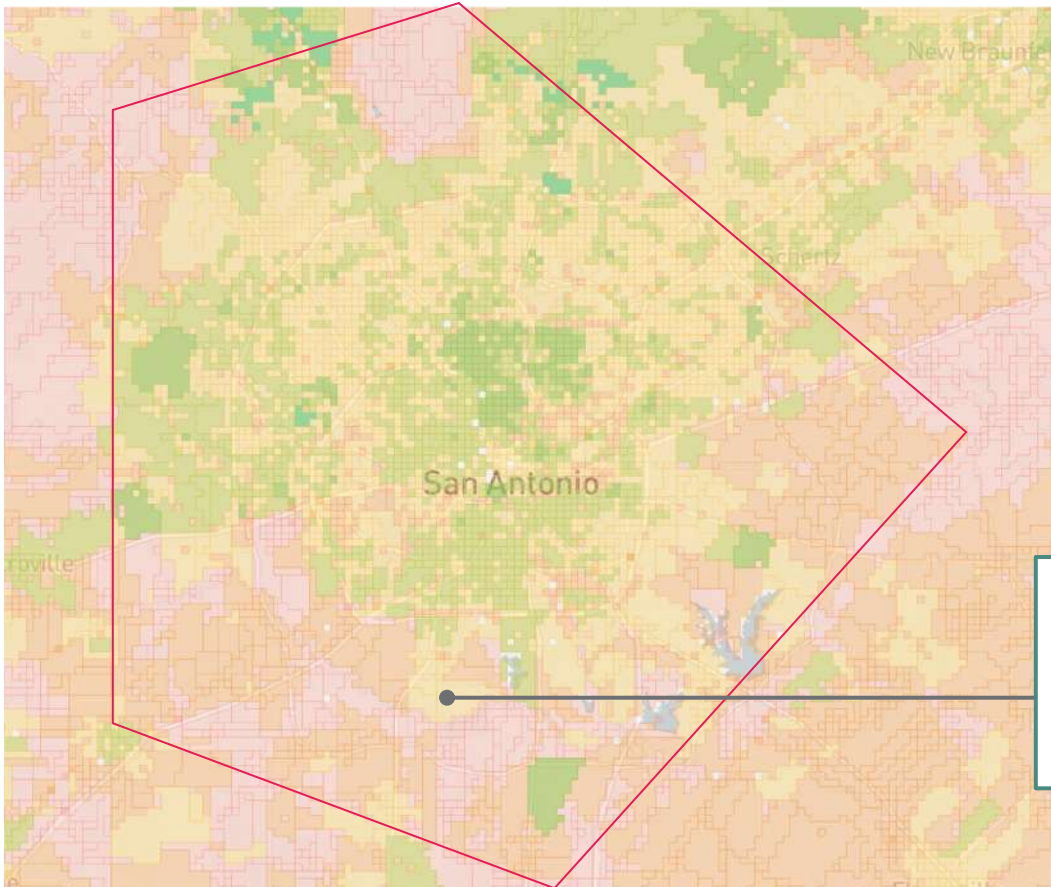

Fiber Coverage

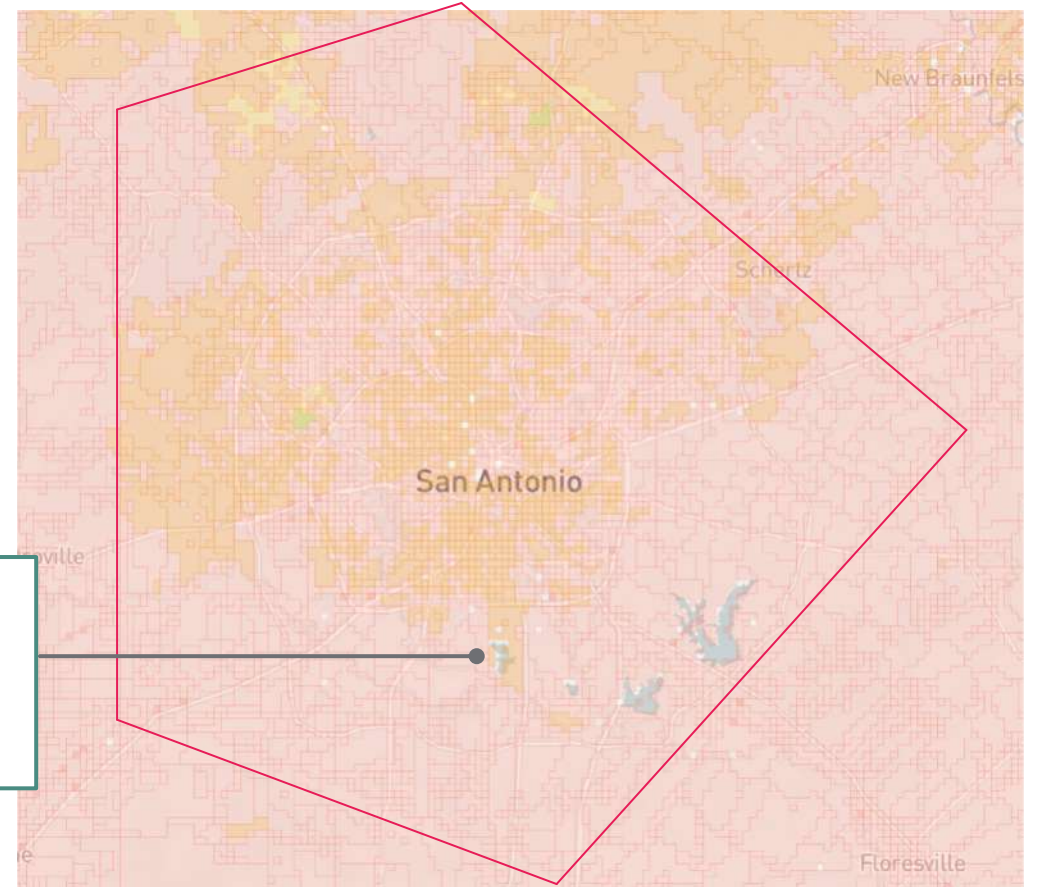

Toyota
Plant
Location

More than 4,000 miles of fiber can be used connect households today or as backbone to extend coverage to additional homes



900 miles of municipally owned COSAnet

- Arranged in two concentric rings around the city¹
- Used for public services e.g., community buildings, public safety departments, remote-operated traffic lights, etc.
- Limited ability to extending access to general public due to legislation



3,000 + miles of privately owned

- **AT&T:** Installed more than 2,600 miles of fiber-optic cable since 2014
- **Google Fiber:** Installed 230 miles of fiber-optic cable, mostly in West SA
- **Zayo Group:** Built 500+ miles of new fiber as part of ESC Fiber 20 program
- **Crown Castle:** Built fiber backhaul
- **Conterra Networks:** Existing circuits serving Edgewood, TBD other districts

CBTC pilots offer model to expand coverage using existing fiber

1. Fiber network owned by city of San Antonio which at present is only used to connect government structures, community buildings, public safety departments, and the city's remote-operated traffic lights. It's managed and maintained by CPS energy.

Source: Institute for local Self-Reliance; San Antonio Report; Digital Inclusion Survey and Assessment (2019)

Context |
Texas law bars municipalities from offering some types of telecommunications services

Prohibited services



Local exchange telephone service

Basic telecommunications service (i.e., end-to-end voice transmission)

Switched access service (i.e., two-way call origination/termination)

Non-prohibited services



Non-voice data transmission service (e.g., standalone **broadband**)

Municipal utilities/public works (e.g., electricity, water)

Case study | Mont Belvieu offers model for legally building a public utility



Overview

Mont Belvieu proactively asked the District Court to address the issue of whether the city could run fiber direct to residents' homes

Mont Belvieu believed it was legally able to deploy a community-wide fiber network as a public service. The court sided with the city

Mont Belvieu issued \$14M in certificates of obligation (COs) to outside investors to fund the deployment of MB Link

MB Link was established as Texas' first municipally owned and operated gigabit internet utility, provides all residents gigabit internet service at \$75/mo. with no data caps



Court reasoning

A municipal broadband network should be considered a public utility (e.g., electricity and water)

“Local exchange telephone service” excludes “non-voice data transmission service” (e.g., standalone broadband)

Fiber optic broadband does not qualify as a “basic telecommunications service”

Table of contents

3	Fact-base
4	Summary
6	Interviews and Community Engagement
19	Inventory Survey
28	K-12 Questionnaire
33	Size and Nature of the Digital Divide
47	ISP Economics & Engagement
56	Initiative Details
57	Infrastructure
93	Affordable Housing Access
104	Education Sponsored
127	Low-income Internet
149	Device Support
162	Adoption Support
191	Data & Analytics
214	Operating Model
244	Population Segments
250	Implementation Roadmap
273	Funding Databases
290	Asset Maps
291	Access Maps
294	Coverage Maps
300	Community Level Maps

Table of contents

3	Fact-base
4	Summary
6	Interviews and Community Engagement
19	Inventory Survey
28	K-12 Questionnaire
33	Size and Nature of the Digital Divide
47	ISP Economics & Engagement
56	Initiative Details
57	Infrastructure
93	Affordable Housing Access
104	Education Sponsored
127	Low-income Internet
149	Device Support
162	Adoption Support
191	Data & Analytics
214	Operating Model
244	Population Segments
250	Implementation Roadmap
273	Funding Databases
290	Asset Maps
291	Access Maps
294	Coverage Maps
300	Community Level Maps

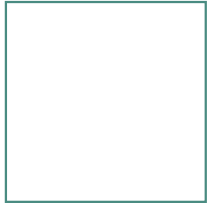

Nature of the problem

Recall | Broadband Access varies significantly across zip codes

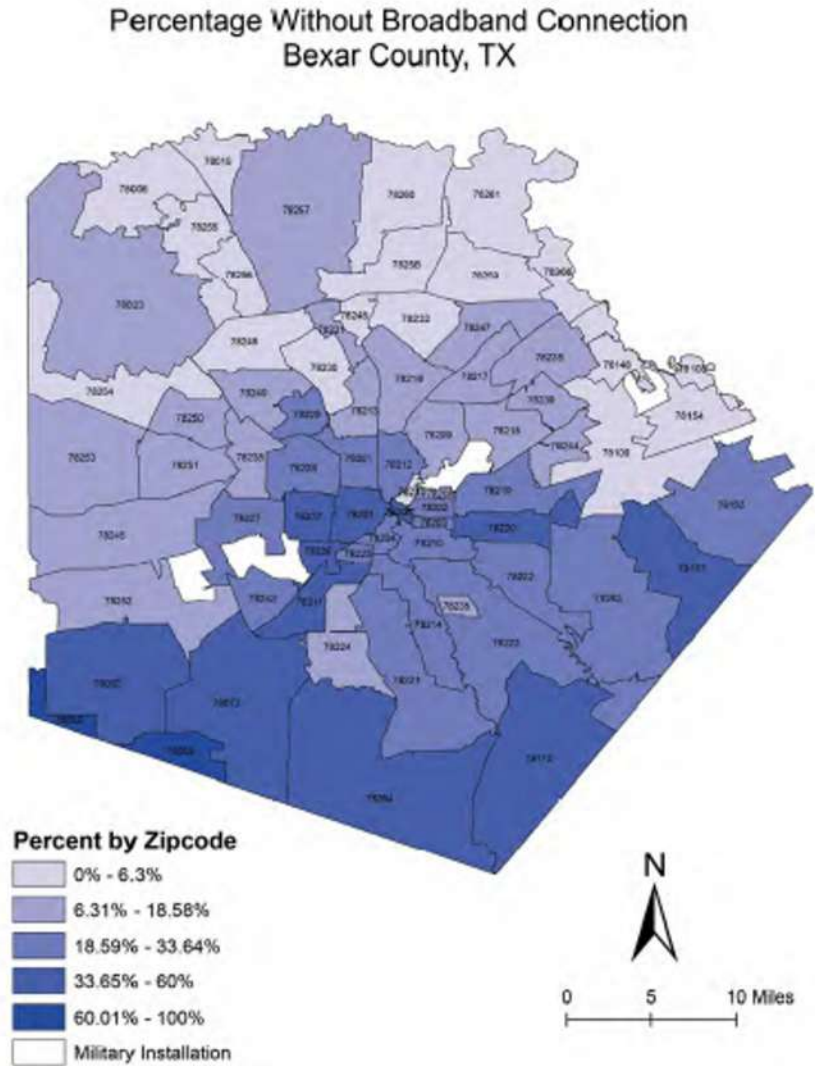

Figure 5: Percentage of Households without Broadband by Zip Code

The Southside and Westside of Bexar County are disproportionately lack access

Lack of Broadband Access by Zip (SASpeakUp)

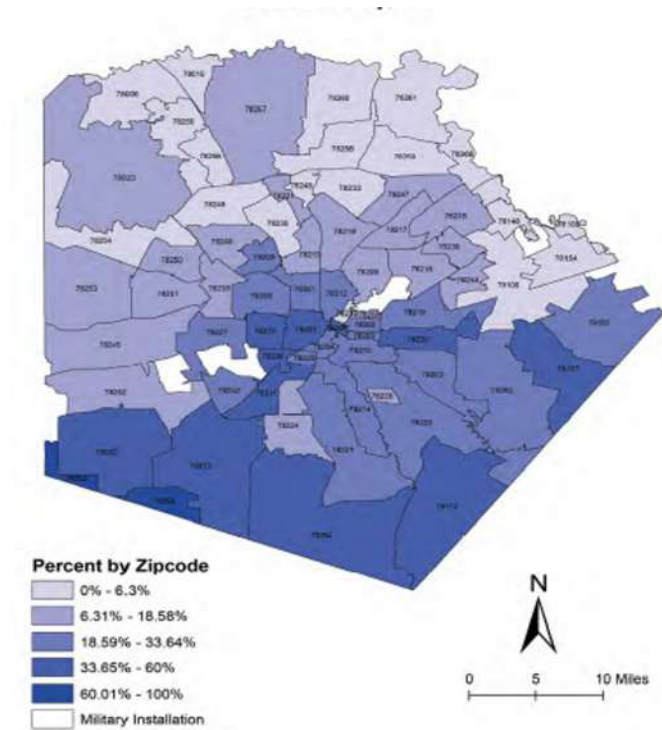
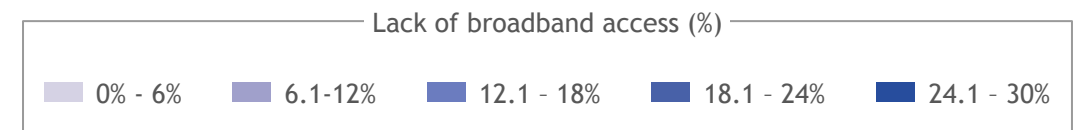
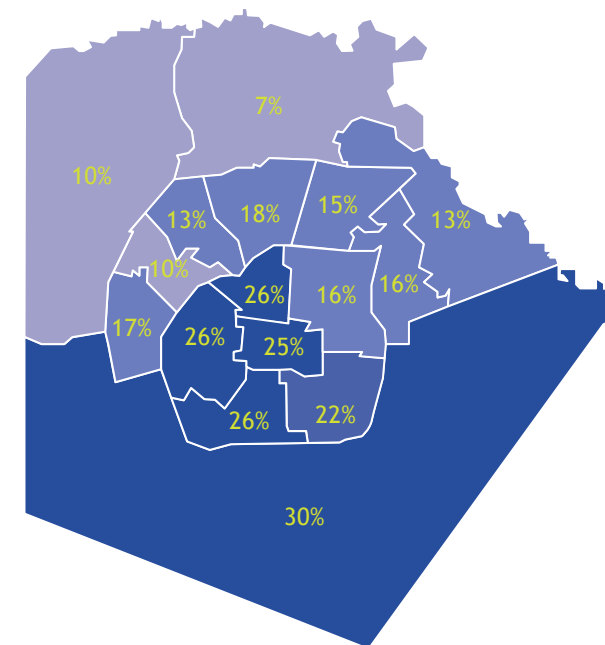

Figure 5: Percentage of Households without Broadband by Zip Code

Lack of Broadband Access by Census Tract (ACS)



Average connectivity speeds experienced by consumers

Average Download Speed, rolling 12 months

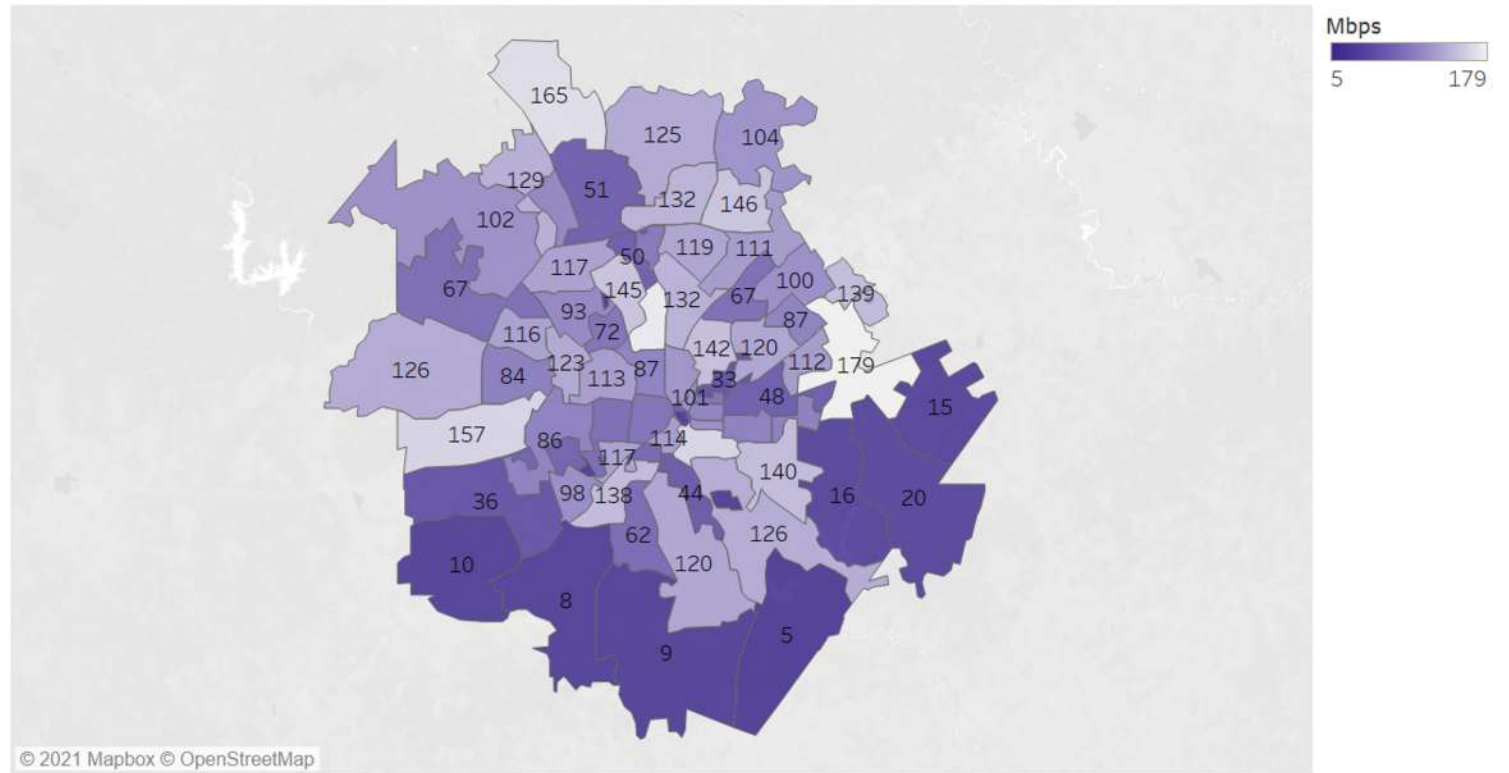

Map based on Longitude (generated) and Latitude (generated). Color shows sum of Average Mbps. Details are shown for Zip. The data is filtered on County, which keeps Bexar.

Some areas on the Southside are served by few providers

Number of providers offering speeds of 100+ Mbps

Number of ISPs present offering speeds of at least 100 Mbps Download / 3 Mbps Upload

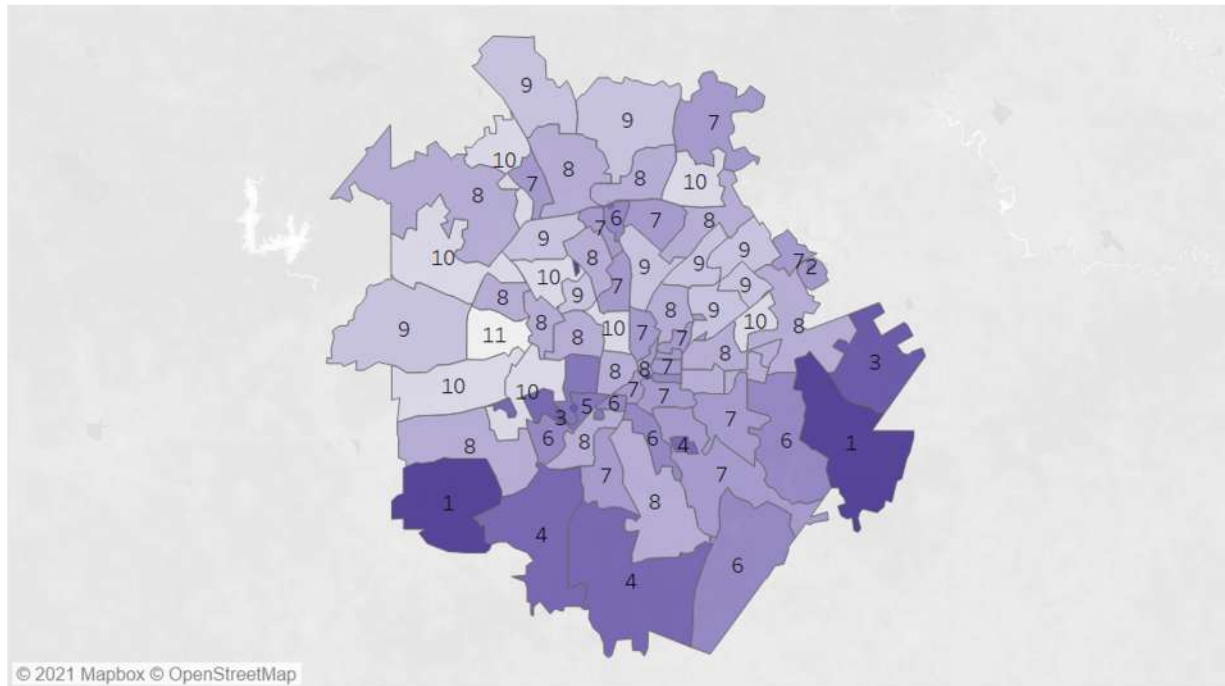

Map based on Longitude (generated) and Latitude (generated). Color shows sum of All100 3. Details are shown for Zip. The data is filtered on County, which keeps Bexar.

Implications for households

- In areas with only one provider, some houses may not be served at all
- Areas with limited provider choice often leads to challenges around affordability and cost of service

Experienced quality in many zip codes is inadequate for basic internet usage

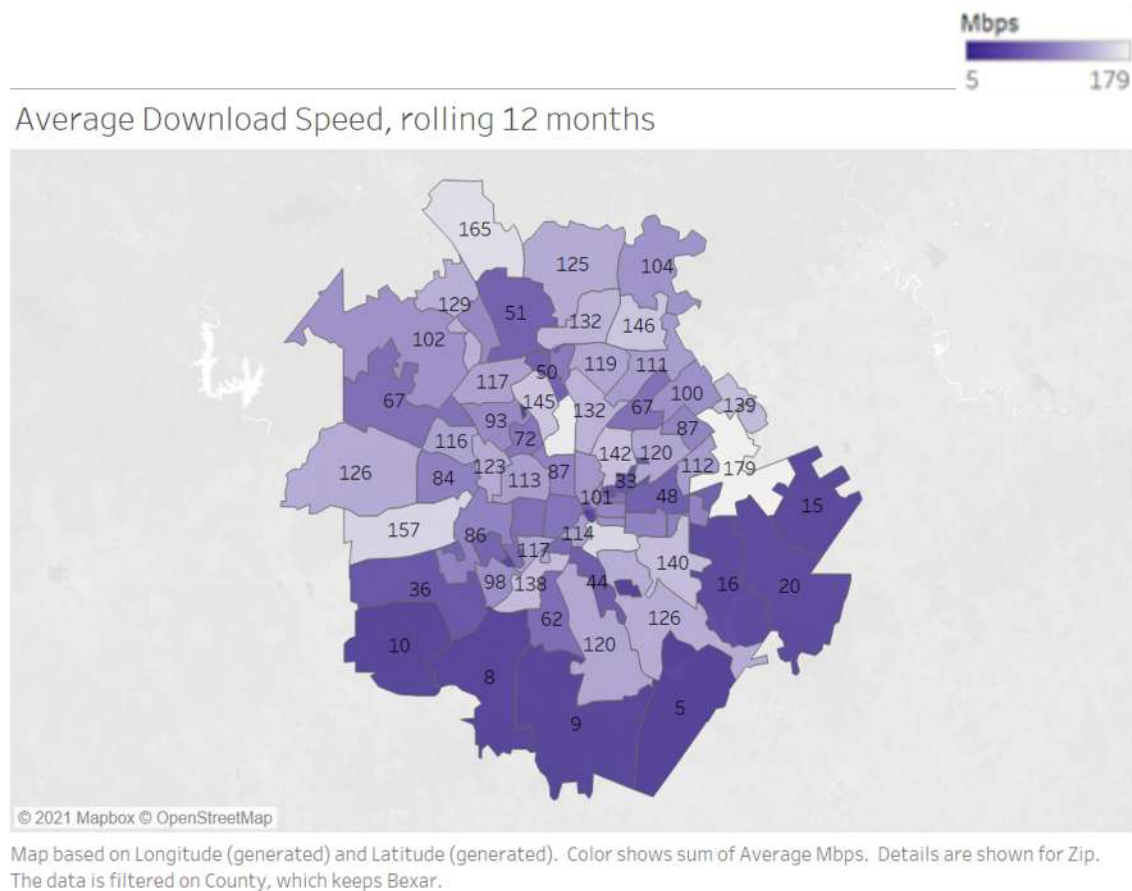

5 Mbps	<1	Unable to support basic internet usage (e.g., group Zoom calls, web browsing, messaging etc.)
25 Mbps	1-2	Supports basic internet usage (e.g., a zoom call)
100 Mbps	3-4	Supports basic and some premium internet usage (e.g., HD streaming)
200+ Mbps	4-5	Support ultra premium usage (4k video streaming, gaming, very large file download)

Several inputs give a directional understanding of where fiber exists today

Reported coverage from BroadbandNow

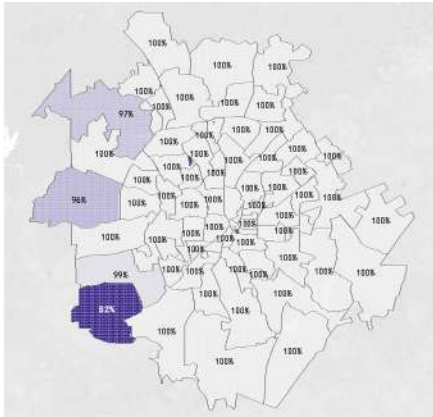

Reported % coverage

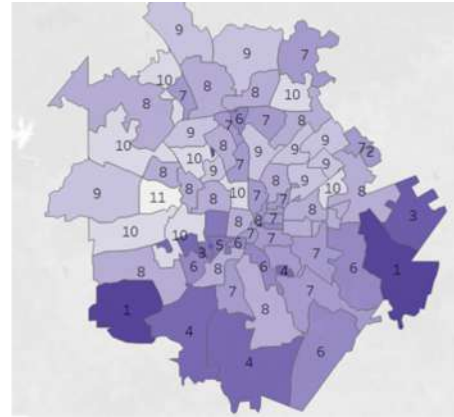

Number of providers



Publicly available fiber lines



Zayo Fiber

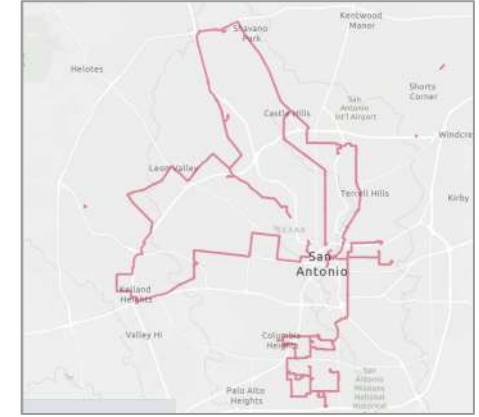

Crown Castle

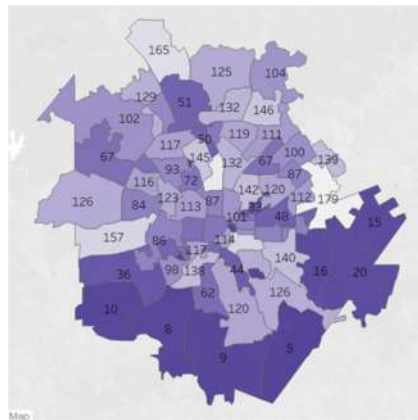

Average speeds

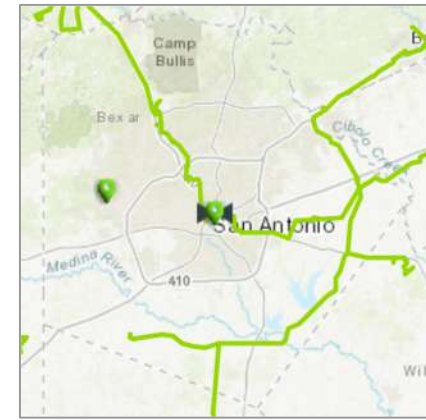

Fiber Light

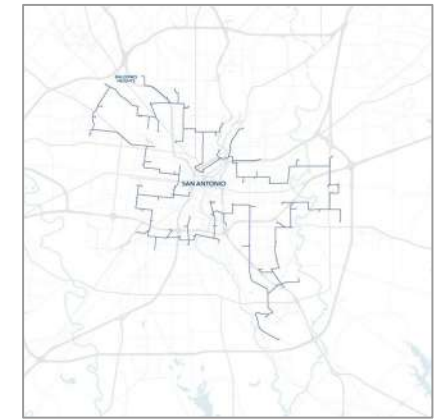

Unite Private Networks

Layered approximation of fiber coverage and number of households without access to fiber

Approximation of extent of fiber by area

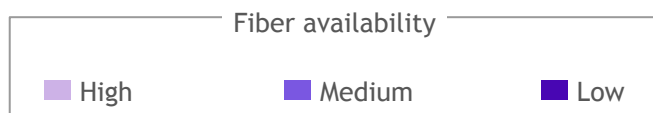
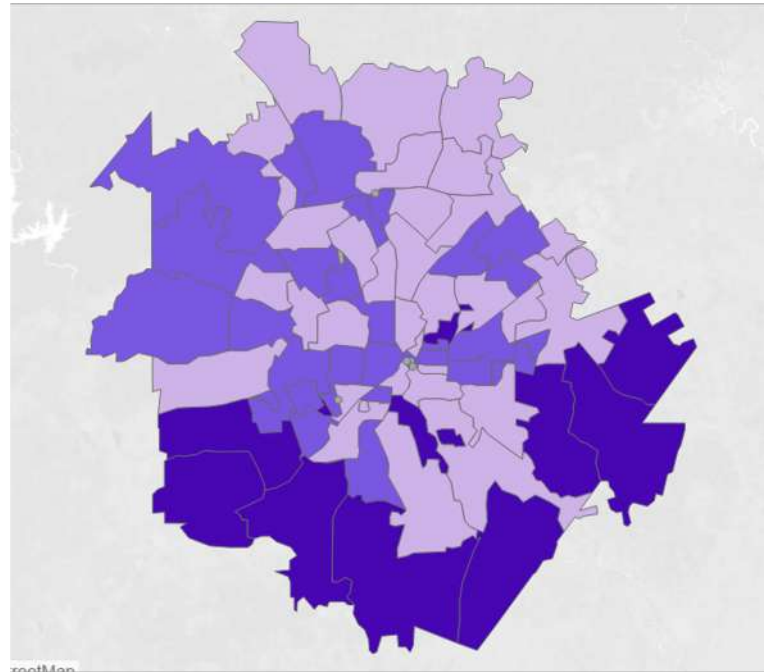

Approximation of the number of households without access to fiber

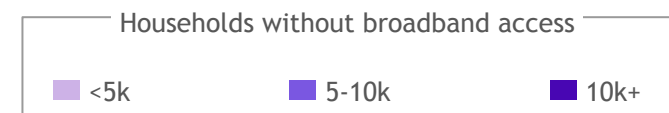
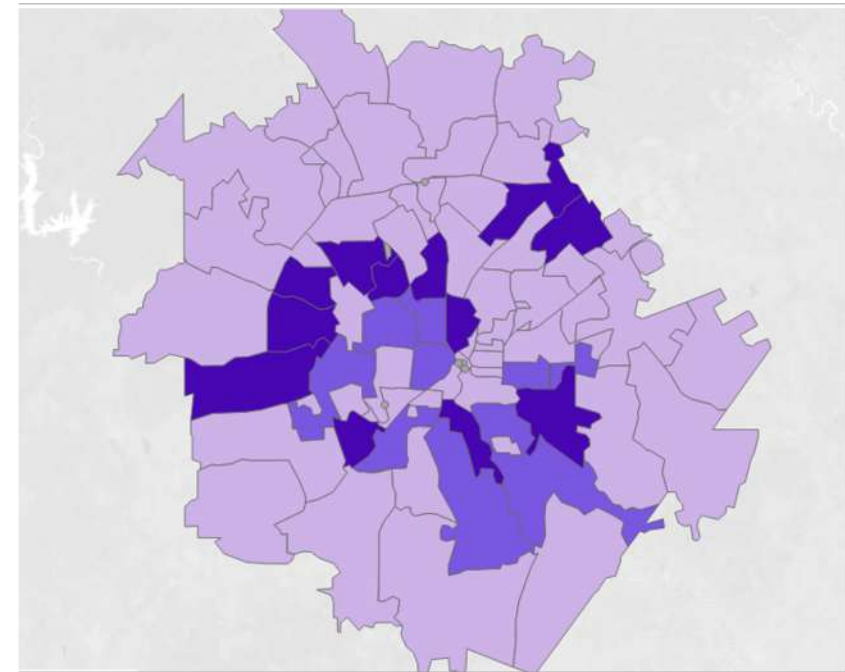

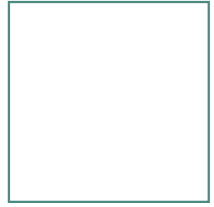

Comparison city research and local efforts

Key themes from infrastructure deployment (fiber)



An incremental approach to fiber deployment can ease financial burden of buildout on municipalities

- **Danville, VA's** community-wide fiber network (nDanville) connected businesses before residential, the more expensive segment to serve directly



For an open access network to succeed, having at least one established ISP on board from the beginning is critical

- **New York's** open access network partners with providers to install, operate, and maintain infrastructure and equipment

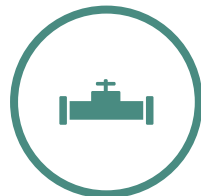

Making use of existing municipal fiber can significantly improve economic viability of deployment

- **Colorado** invested regional fiber network (Project THOR) leveraged 400 miles of existing municipal middle-mile fiber, significantly reducing costs



Local market context should determine whether municipalities pursue middle-mile v. last-mile access

- **Seattle's** initial attempt at a \$2B city-wide fiber network was intended to deliver last-mile internet and services directly to households

Case study | Mont Belvieu offers model for legally building a public utility



Overview

Mont Belvieu proactively asked the District Court to address the issue of whether the city could run fiber direct to residents' homes

Mont Belvieu believed it was legally able to deploy a community-wide fiber network as a public service. The court sided with the city

Mont Belvieu issued \$14M in certificates of obligation (COs) to outside investors to fund the deployment of MB Link

MB Link was established as Texas' first municipally owned and operated gigabit internet utility, provides all residents gigabit internet service at \$75/mo. with no data caps



Court reasoning

A municipal broadband network should be considered a public utility (e.g., electricity and water)

“Local exchange telephone service” excludes “non-voice data transmission service” (e.g., standalone broadband)

Fiber optic broadband does not qualify as a “basic telecommunications service”

Case study | Open Access—Danville, VA

The city's public utility company (water, gas, electricity) launched nDanville, an open access network offering businesses/households speeds between 50 Mbps and 10 Gbps. The network is self-sufficient and returns \$300k/year to the city in profit



Incremental approach

To mitigate risk and lower capex costs, nDanville slowly built out from least to most expensive segments to serve (i.e., from commercial to residential) over 11 years



Established first partner

Gamewood, nDanville's network operator, had an established presence that helped the city attract other ISPs to the network and support residential buildout with triple-play offerings (e.g., phone, internet, TV)



Dig once for future scaling

When permitting various construction projects, Danville includes laying fiber conduit to meet future data demand at scale



Community engagement/marketing

City goes into communities to hold meetings and distribute promotional material ahead of any network expansion to support word-of-mouth marketing and increase take rate

Takeaways

An incremental approach to fiber deployment can ease financial burden of buildout on municipalities

For an open access network to succeed, having **at least one established ISP** on board from the beginning is critical

Triple-play offerings are vital to retain residential customers who expect more than standalone internet

Case study | Project THOR - Colorado

A group of local governments and private partners launched Project THOR, a middle mile fiber network providing backhaul to public facilities, schools, hospitals, and other community anchor institutions



Regional network

Multiple cities share both revenue and cost for deployment / maintenance in addition to aggregating demand across several localities, enabling THOR to charge prices at half the rate of competitors



Repurposing existing municipal fiber

Much of THOR network is made up of dark fiber segments sourced from carriers and public agencies, making the project affordable for the localities involved



Middle-mile access

Rather than enter the fiercely competitive last mile market, THOR's position in middle-mile allows the network to provide access across segments



Network redundancy

The THOR network's rung design prevents a single fiber cut from knocking an entire city offline, which has been a significant attraction to providers

Takeaways

A regional approach to fiber deployment can ease financial /operational burden of buildout on any single municipality

Making use of existing municipal fiber can significantly improve economic viability of deployment

Local market context should determine whether municipalities pursue middle-mile v. last-mile access

LOCAL EFFORTS

Three distinct pilots underway, with Texas A&M SA providing support and evaluation across pilots



CBTC (COSA)

Leveraging existing ISD / COSANet network offer in-home connection via WiFi; current focus on 13K students in SAISD, Edgewood, and Harlandale



CBTC (City Education Partners)

Building a private LTE network on Edgewood's 10 gig circuit and small cells to offer in-home connection via routers



BiblioTech Connect Pilot (County)

Deploying a private LTE network with small cells on water towers to extend wireless service to homes for 100 Southwest ISD students



Evaluation/help desk (Texas A&M SA)

Providing continuous evaluation of pilots through data collection, interviews, and household surveys; piloting a help desk model to support digital adoption / skills

Many efforts are underway to expand broadband infrastructure

Key policies	Description
Connected Beyond the Classroom City Pilot	<ul style="list-style-type: none"> Initiative to leverage and supplement existing ISP/municipal infra. and provide holistic support to connect 20K students; includes 8 ISDs, 3 ISDs and 13K students selected for pilots
BiblioTech District Pilot	<ul style="list-style-type: none"> Initiative to offer free digital library services to children and families. Targeting 100 students; ~50 successfully connected to date
SAHA Public Housing	<ul style="list-style-type: none"> Housing units are being retrofitted to accommodate public Wi-Fi, connecting 30K households
Operation Connectivity	<ul style="list-style-type: none"> Statewide initiative since March to offer device and connectivity to students for free; commitment to support affordability and infra. build-out post pandemic
National hotspot programs	<ul style="list-style-type: none"> Includes 10 GB/mo from Sprint 1 million; 100 GB/year from T-Mobile Project 10 million or 5 GB/mo through ConnectED
VIA Hotspots	<ul style="list-style-type: none"> Transit authority set up free mobile hotspots though fleet of VIAtrans equipped with high-speed Wi-Fi networks

Local Efforts: Broadband Infrastructure

Organizations supporting this type of work

- Good Samaritan Community Services
- UT Health San Antonio
- YMCA of Greater San Antonio
- SAISD/AYVP/ Project SEARCH
- SAISD
- San Antonio Housing Authority
- Madonna Center, Inc.
- Alamo Colleges District
- City Education Partners



Examples of how orgs have supported this initiative

- “ We provide free public wifi at our properties - City Education Partners
- “ We have fund raised and built a private wireless network that extends a school districts existing Internet connection into the neighborhoods and households directly surrounding for school sites in Edgewood ISD - City Education Partners
- “ We have advocated for funding and the creation of a broadband plan in the Texas Legislature, and encouraged our members to do the same - San Antonio Chamber of Commerce

Details | Progress update on CBTC rollout

	SAISD	Edgewood ISD (COSA)	Harlendale ISD	Edgewood ISD (CEP)
Fiber source	COSAnet	ISD fiber		ISD fiber (Conterra Networks)
Deployment	4 posts (fire station, radio tower, 2 libraries)—limited capacity/ capacity mgmt.	Point-to-multi-point from school to home		
Current state	<p>Launched</p> <ul style="list-style-type: none"> • Launched once SAISD could fund PMO • Slow adoption due to recent school breaks, awareness building on benefit vs. hotspots, manual sign-up process 	Completed site assessments; awaiting approval to build		<p>Launched</p> <ul style="list-style-type: none"> • Live at 4 sites with only 12 students connected • Manual outreach processes has slowed adoption
Target reach	<ul style="list-style-type: none"> • 3 neighborhoods • 9K target students 	<ul style="list-style-type: none"> • 3.2K students 	<ul style="list-style-type: none"> • 2 neighborhoods • 800 students 	<ul style="list-style-type: none"> • 800 students

Currently capacity constrained to 1.2K students

ISD using own funds to extend access to full district

Deep Dive | Connected Beyond the Classroom model



- No data caps vs. ISP hotspot programs
- More cost effective (\$8/mo cost vs. \$50/mo ISP rack-rate)
- Addresses both availability and affordability



Limitations

- Lower avg speeds (15/1 mbps for City pilots; 25-50 mbps for CEP pilot) better for individual usage
- Localized deployment limits capacity, capacity management (e.g., on libraries, fire houses)
- Potential municipal headwinds expanding beyond students

CBTC offers model to get households from “none-to-some”, extending overage where none exists and offering services at an affordable rate (vs. existing options)

Learnings

Engage the community, district to support adoption and offer 1:1 support

Assess efforts for ROI

- **CEP pilot:** \$325K investment for 800 students (\$400/student)
- **COSA pilot:** \$27M for ~13K students (\$2K/student)

Consider structural aspects of deployment (e.g., 120 ft tower has the strongest coverage, able to cut through tree canopy)



Recommendation

1

Infrastructure solutions

Detailed recommendations

Preliminary

- 1A **Develop a granular map (e.g., household, neighborhood level) to identify areas without adequate broadband infrastructure today**
 - Identify areas where fiber availability is insufficient, sufficient and affordable, or sufficient but unaffordable
 - Identify other 'hard' assets (e.g., vertical assets, cell/radio towers) that could be leveraged to extend broadband infrastructure
 - Conduct household speed tests to assess quality of service and internet speeds

- 1B **Develop deployment and network design strategies, working collaboratively with internet providers that achieve key metrics (e.g., speed, reliability, cost)**
 - Partner with ISPs to identify and remove barriers to deployment (e.g., legacy copper) in unserved or underserved areas (fiber exists but unaffordable),
 - Deploy municipal open-access network and lease to ISPs for residential service
 - Define standards for adequate service quality to meet the needs of households (e.g., education, telehealth, online job applications)
 - Utilize other financial and policy levers to incentivize ISPs to participate in deployment (e.g., grants, dig once, cost sharing, demand aggregation)
 - In areas where fiber deployment is not feasible, determine and deploy the appropriate mix of alt. last mile tech (e.g., fixed wireless, mesh, satellite)

While ensuring universal access will require a **portfolio of solutions** based on service quality, cost, and local context...

... Fiber should be deployed where feasible given its maturity and speed potential

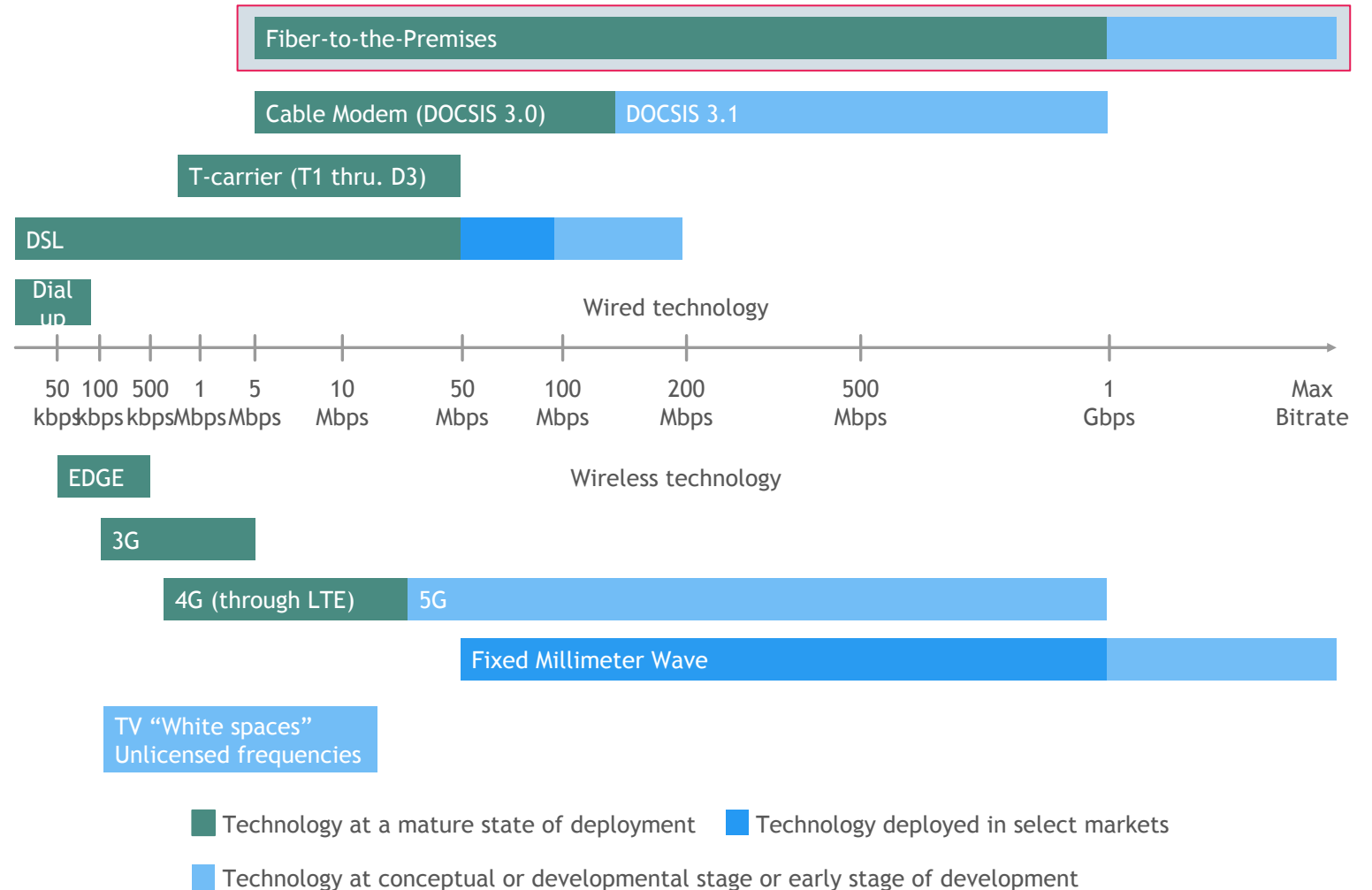

Key questions to inform fiber deployment



What areas lack access to affordable fiber today?

- What areas have no areas to fiber today?
- What access may have some fiber but lack affordable access due to low population density, competition?



What will it cost to deploy in each area?

- Where middle mile costs are necessary?
- What last mile costs are necessary?
- How does this vary by population density?



What are the tools and resources do we have at our disposal?

- What federal, state and local funds do we have right to win?
- What laws and policies can enable deployment (e.g., circumventing municipal restrictions, capacity leasing)?
- What modes of demand aggregation can induce private sector engagement?

COSA / Bexar has several tools at its disposal to engage ISPs and encourage fiber deployment

Illustrative, non-exhaustive



Fiscal levers

- Grants: Target federal funding applicable to broadband deployment (e.g., Broadband Infrastructure Deployment Grant, EDA Appropriation)
- Municipal bonds: Issue municipal bonds backed by COSA / BC assets to finance fiber deployment
- Cost sharing: Divide costs of fiber buildout between COSA / BC and ISPs to reduce financial burden
- CRA loans: Apply to receive bank loans under Community Reinvestment Act to finance deployment
- Demand aggregation: Combine service areas to favorably shift economics for ISPs and encourage investment



Policy levers

- Permitting: Ease ISP permit application requirements to expedite broadband expansion
- Open Access: Sell wholesale access of municipal network to ISPs who, in turn, offer retail services to residents
- Right of way: Allow providers to construct and maintain facilities in the right of public highways
- Dig once: Provide ready-made, buried conduits, enabling providers to more easily and cheaply install fiber

Recall | Municipalities can also support middle and last mile fiber deployment in several ways



Municipal provider

Build infrastructure for city /county to own and operate and provide access directly to residents

- Mont Belvieu, Texas: Developed MB Link, Texas' first municipally owned and operated gigabit internet utility



Wholesaler/Open Access

Build infrastructure but lease/offer access to multiple providers for last mile delivery¹

- Lincoln, Nebraska: Starting in 2012, laid 500 miles of fiber leased to 8 ISPs to become a Smart Gigabit Community

Recommended



Lease-to-own/sell off

Build infra. and transfer management to ISPs who split revenue and costs to deploy with municipality

- Oconee County, South Carolina: Entered 20-year lease-to-own agreement with OneTone for \$6.3M



Grants

Auction grants where ISPs can bid to build broadband infrastructure, with relevant requirements

- Alabama: Provides grants to ISPs to build minimum threshold broadband service (25/3 Mbps) in unserved areas

1. There are a range of models of wholesaler and open access with varying degrees of retail competition. Source: Community Networks; Institute for Local Self-Reliance; BroadbandNow

Recall | Considerations on choosing a path for fiber deployment



Municipal provider

- + Autonomy in deployment
- + Highest demand aggregation
- + Maximize use of existing municipal infrastructure

- Potential legal conflicts
- Greatest ongoing financial burden on city
- Lacks ISP expertise, infrastructure and scale



Wholesaler/Open Access

- + Minimizes friction of middle mile costs
- + Fosters competition among providers
- + Reduces prices through provider capex savings

- City bears financial burden of buildout and maintenance

Recommended



Lease-to-own/sell off

- + Encourages deployment while maintaining accountability
- + Reduces up front investment hurdles

- May create financial risk for the municipality
- Requires a high degree of ongoing collaboration



Grants

- + Fosters competition on innovation, customer service, and price
- + Fully leverages ISP expertise and infrastructure

- Limited ability to drive accountability and ensure universal access
- Limited ability to change the provider economics model

Benefits

Drawbacks

How open access works

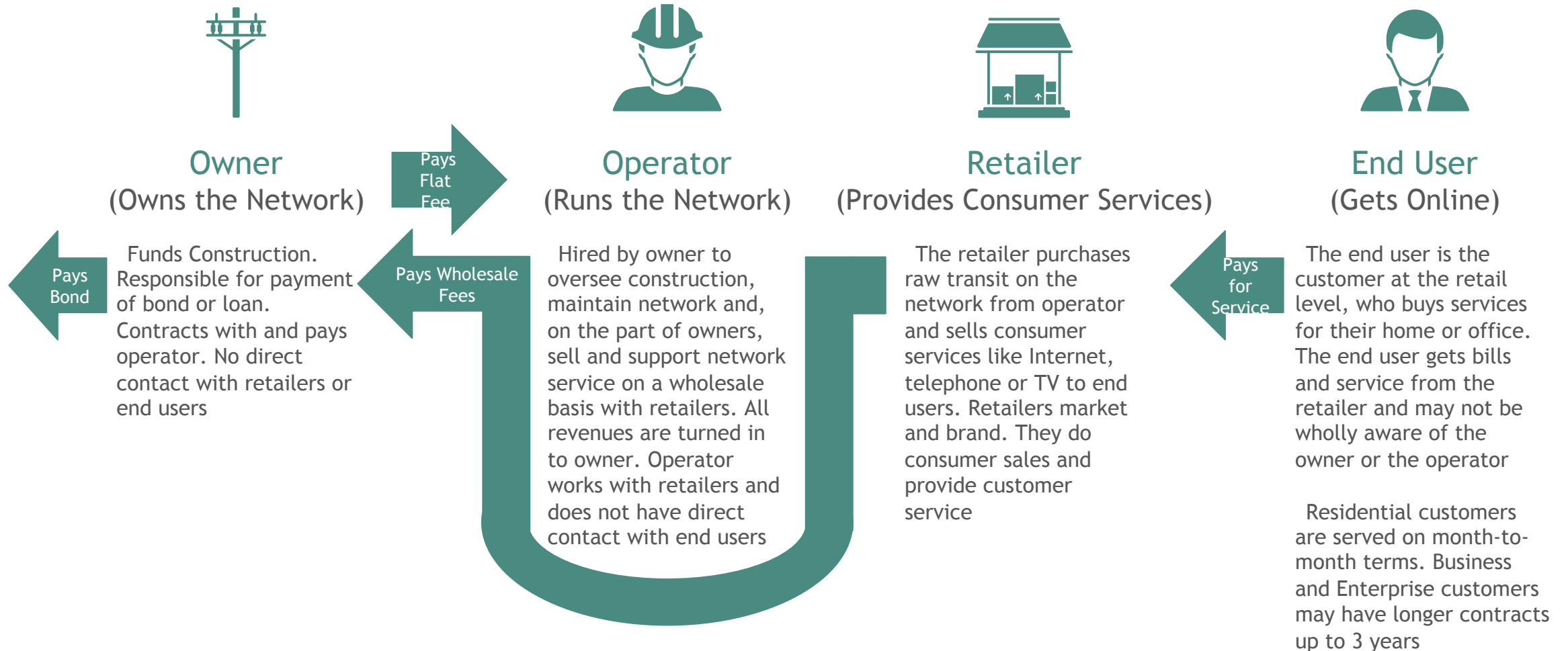

Simplified version of telecommunication network to public internet

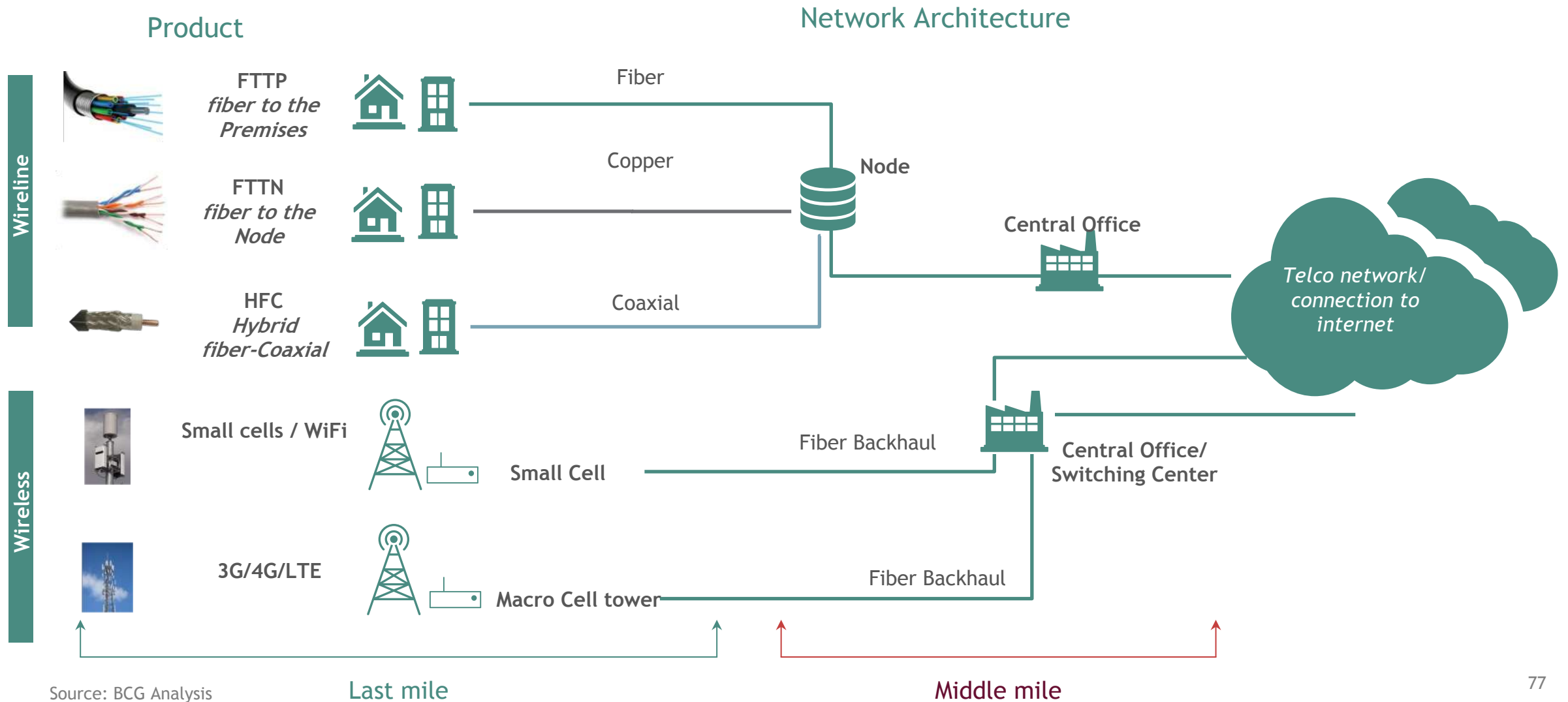

A variety of equipment is required to deliver services from customer to core network

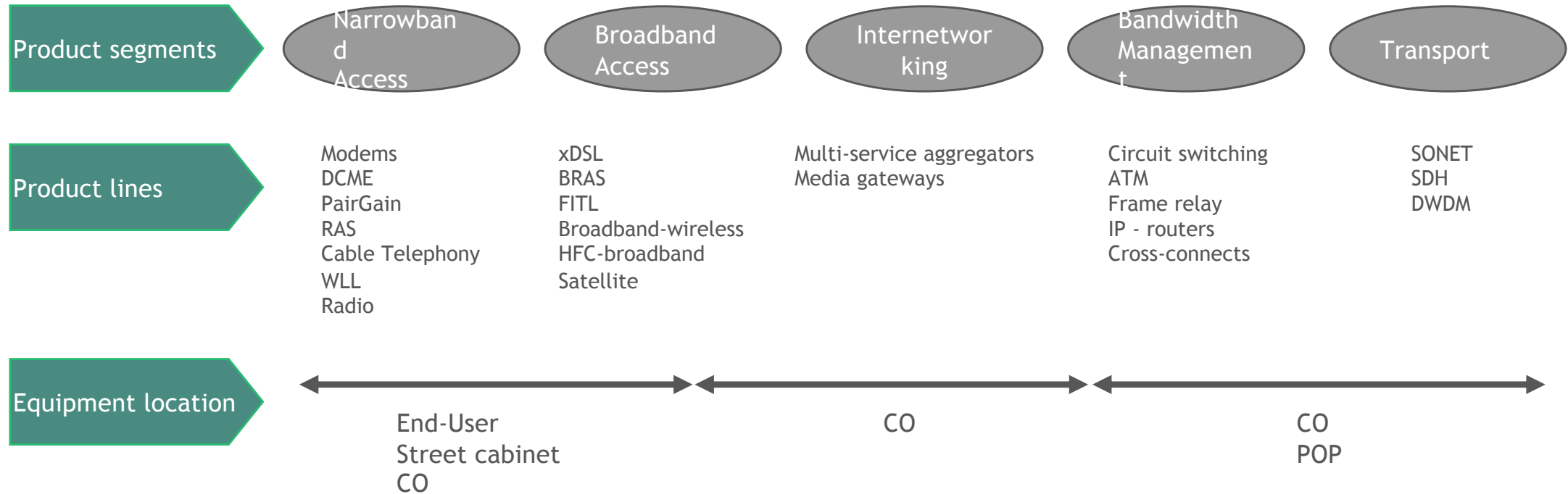

Range of open access models exist, with implications for ISP competition



Middle-mile only

Municipality builds and maintains fiber backbone and leases fiber to ISPs to build last-mile to homes and businesses

- **Project THOR (CO):** A group of local govt' and private partners provide backhaul to public facilities, schools, and hospitals

Least competition from ISPs



Build to commercial

Municipality builds/maintains fiber to individual businesses and leases out to ISPs who offer services (e.g., phone, internet) to customers

- **Mount Vernon, WA:** Started in 1995, fiber network serves government, schools, hospitals, and businesses



Build to residential

Municipality builds / maintains fiber to homes and leases out to ISPs who serve as sales & marketing to customers

- **nDanville (VA):** Open access fiber network serves businesses and households at speeds between 50 Mbps and 10 Gbps

Most competition from ISPs



Recall | Several inputs give a directional understanding of where fiber exists today

Reported coverage from Broad band Now

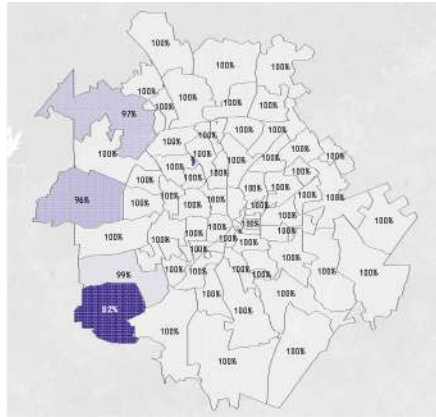

Reported % coverage

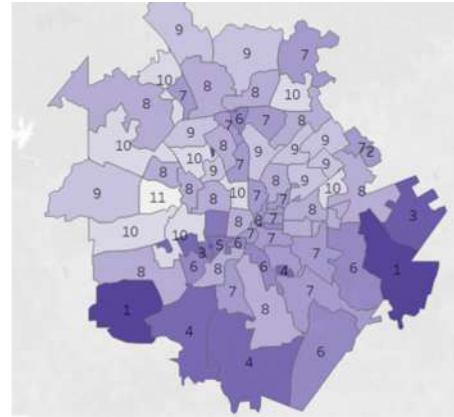

Number of providers



Publicly available fiber lines



Zayo Fiber

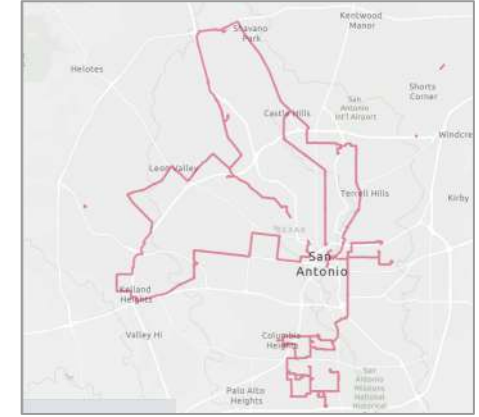

Crown Castle

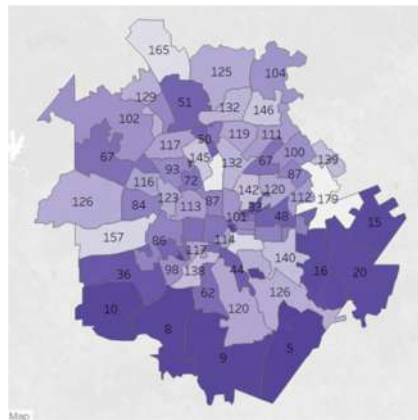

Average speeds

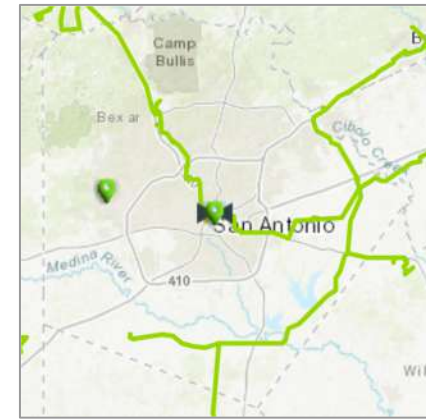

Fiber Light

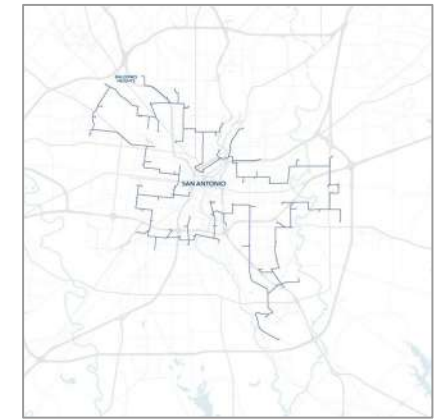

Unite Private Networks

Other deployments should be considered where cost to deploy fiber not economically feasible

Fiber-to-the-home deployment costs per household

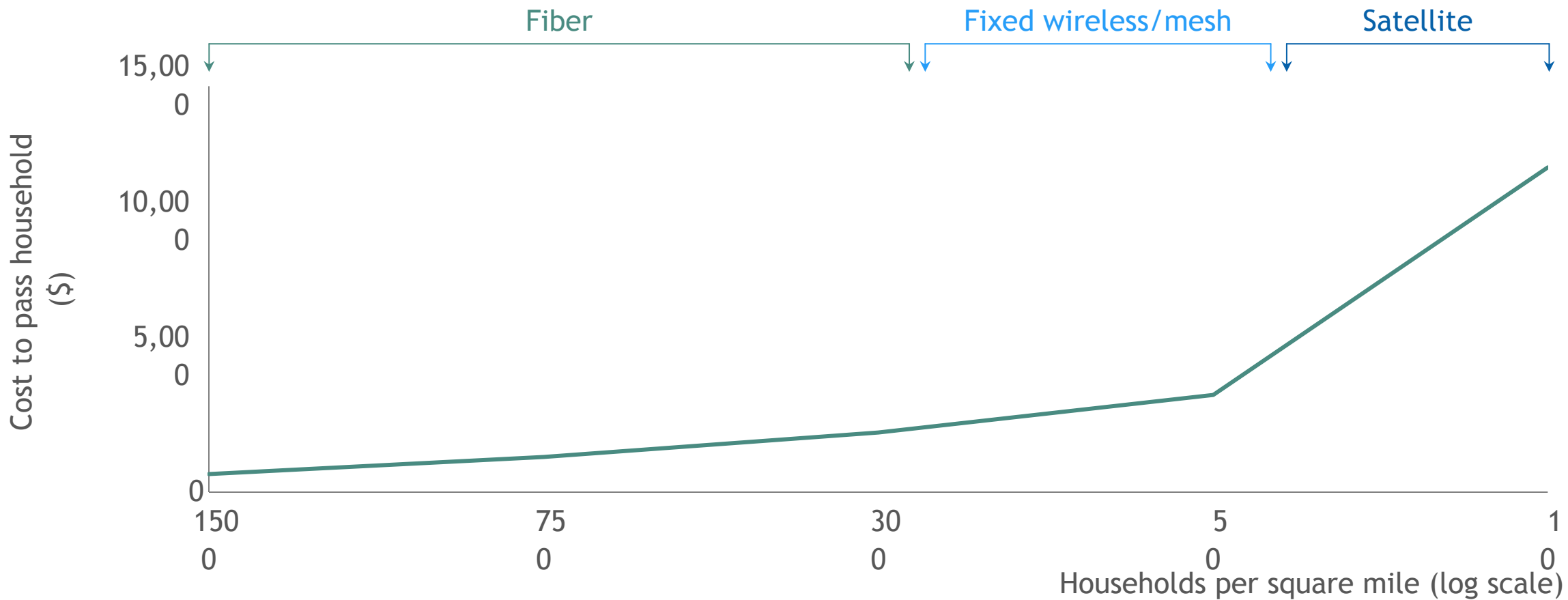

Source: Fiber Broadband Association

Three key alternative technologies to consider



5G point-to-multipoint (P2MP) fixed wireless

Delivers internet connectivity from the main access point to customer receivers via cellular networks

- Rocket Fiber—Detroit, MI: Delivers 1 Gbps P2MP connection shared among several multi-family residential units



Mesh network

Delivers internet connectivity via interconnected networks of devices acting as nodes

- SAHA Cassiano Homes: Delivers Wi-Fi to 1,800 residents over mesh network covering 50 acres









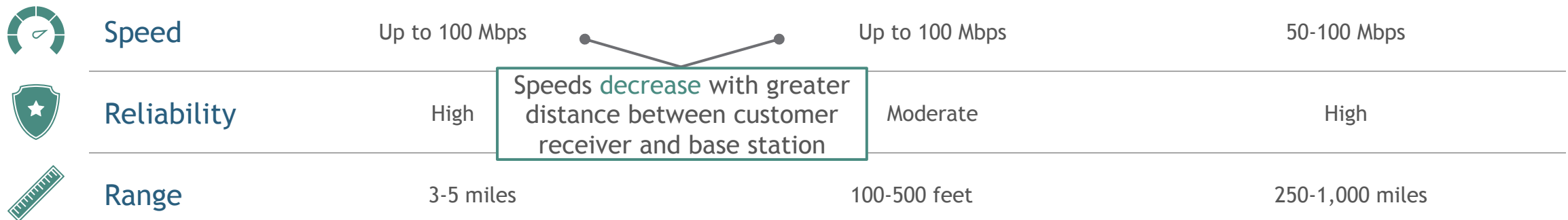

Low earth orbit (LEO) satellite

Delivers internet connectivity via fleet of low earth orbit satellites and customer antennas

- SpaceX Starlink: Delivers internet to 10,000 customers through fleet of 1,500 LEOs



Considerations around deployment of each technology

	P2MP fixed wireless	Mesh network	LEO satellite
 Deployment cost per household	\$200-400 amortized cost for radio tower and equipment (e.g., base station, electronics)	~\$50-100 for radio receiver/node placed on each home	\$500-800 for antenna hardware / installation required for each home
 Monthly household price for service	\$40 to \$100/mo.	\$50 to \$80/mo.	\$60 to \$150/mo.
 Required proximity to fiber	Yes	Yes	No
			
 Recommended usage	Dense urban/peri-urban areas where fiber trenching is not economically feasible	Short range/concentrated areas (e.g., industrial parks, university campuses, public housing) with excess capacity	Low density/rural areas with limited fiber availability
 Recommended % of SA/ Bexar households covered	5-10%	<5%	<5%

Total of **20-30% of households** covered with non-fiber solution

Technology deployment will vary across San Antonio/Bexar

Potential deployments identified

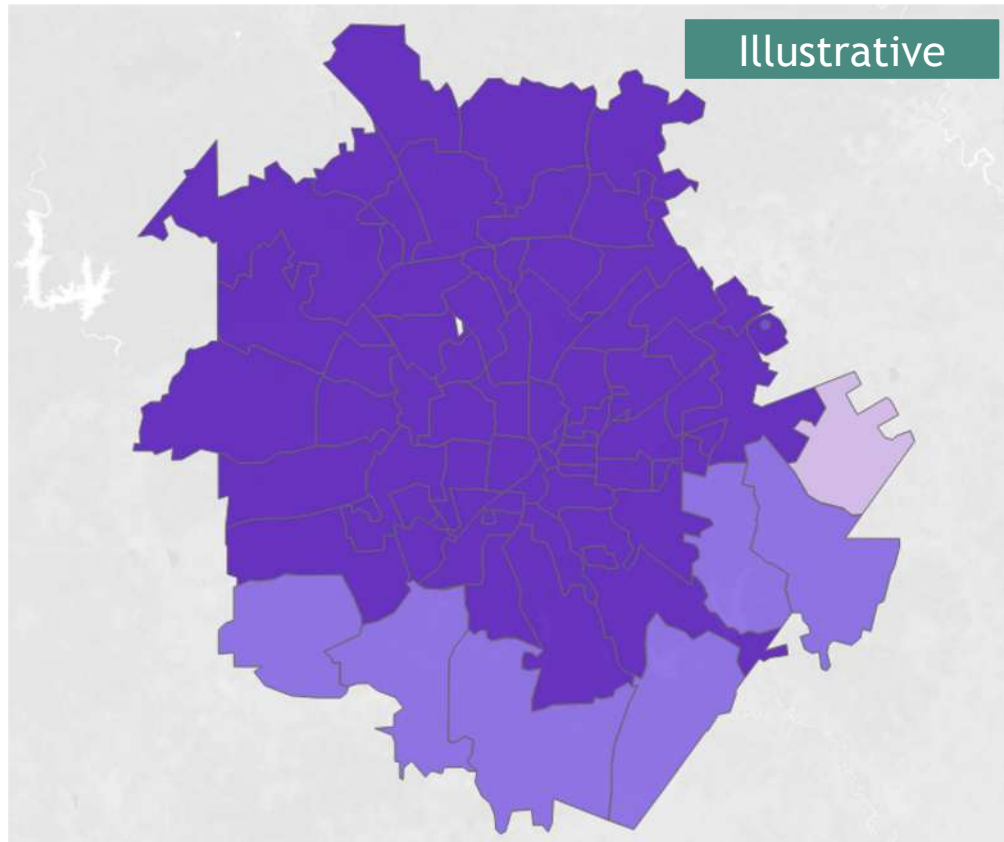



Deployment type ■ Fiber ■ FWA + mesh ■ Satellite

Source: BroadbandNow, 2020 US Census

Categories for deployment

- 

Fiber
Areas with sufficient pop. density (i.e., >250 hhds./sq. mile) to support last mile fiber deployment to homes/businesses
- 

Fixed wireless/mesh
Areas with sufficient pop. density (i.e., 100-250 hhds./sq. mile) to support middle mile fiber deployment
- 

Satellite
Areas with insufficient pop. density (i.e., <100 hhds./sq. mile) for fiber deployment for middle or last mile

Deployments for each technology will vary depending on available infrastructure funding and future unlocked fiber capacity

Table of contents

3	Fact-base
4	Summary
6	Interviews and Community Engagement
19	Inventory Survey
28	K-12 Questionnaire
33	Size and Nature of the Digital Divide
47	ISP Economics & Engagement
56	Initiative Details
57	Infrastructure
93	Affordable Housing Access
104	Education Sponsored
127	Low-income Internet
149	Device Support
162	Adoption Support
191	Data & Analytics
214	Operating Model
244	Population Segments
250	Implementation Roadmap
273	Funding Databases
290	Asset Maps
291	Access Maps
294	Coverage Maps
300	Community Level Maps

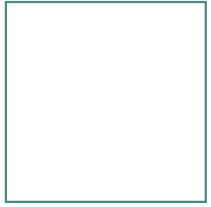

Nature of the problem

Recall | San Antonio and Bexar residents face a significant digital divide...



20% (390K) of San Antonio/Bexar residents lack access to broadband



...With significant differences across districts, e.g.,

- District 5: 38% lack access
- District 9: 6% lack access



10% (195K) of San Antonio/Bexar residents lack access to devices

...Driven by several factors

Reasons for not using internet (% of respondents)

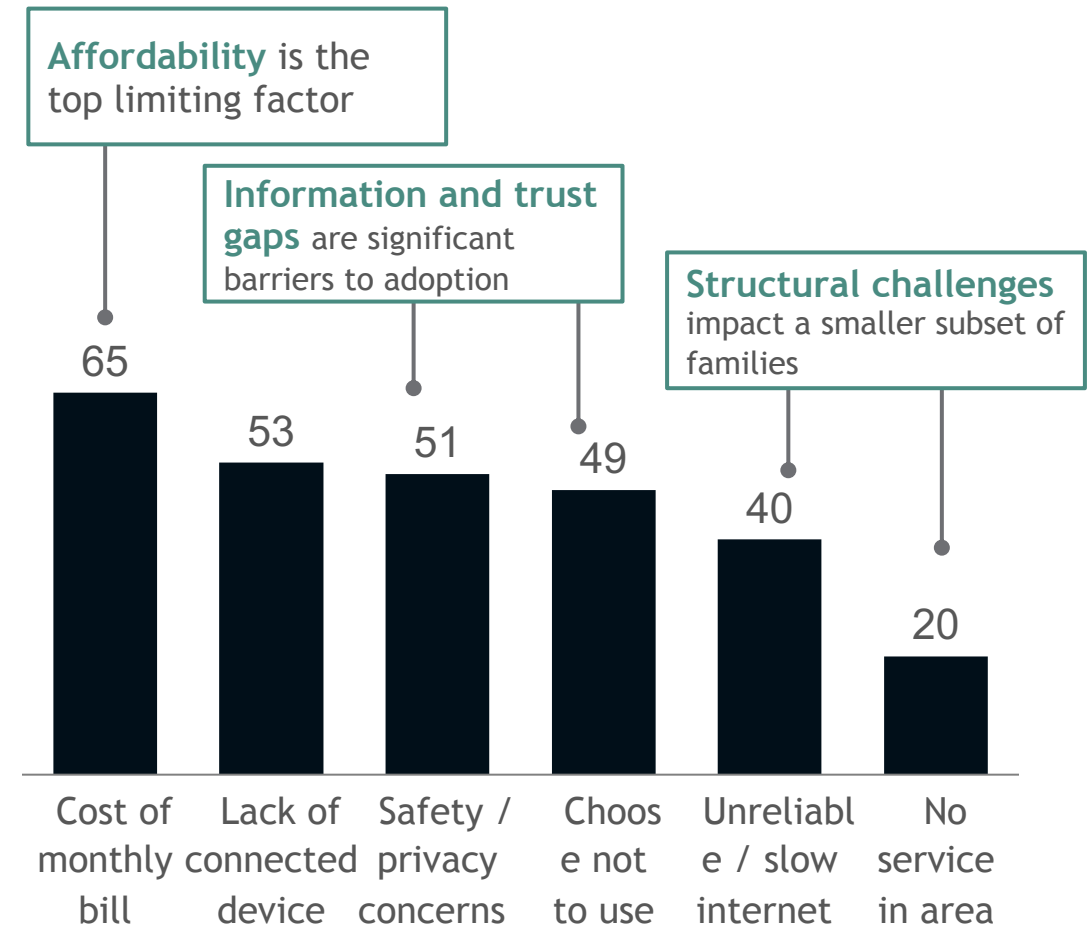

Affordability and adoption are the greatest barriers to access; extent of availability challenges varies by source and service quality

Category	Sources	# and % of households	Considerations
Availability: Unserved	Broadband Now	5K (0.8% of HHDs)	<ul style="list-style-type: none"> Unserved by 25 mbps coverage
	SASpeakUp ¹	27K (4% of HHDs)	<ul style="list-style-type: none"> Reported not having internet because there was no service in their area
Availability: Underserved	Broadband Now	9K (1.4% of HHDs)	<ul style="list-style-type: none"> Unserved by 100+ mbps coverage
	SASpeakUp	53K (8% of HHDs)	<ul style="list-style-type: none"> Reported not having internet because service was slow or unreliable
	Broadband Now	201K (30.1% of HHDs)	<ul style="list-style-type: none"> Unserved by 1 gig coverage
Affordability	SASpeakUp	87K (13% of HHDs)	<ul style="list-style-type: none"> Reported not having internet because could not afford the monthly bill
	ACS data	211K (33% of HHDs)	<ul style="list-style-type: none"> % with income less than \$50K, proxy income for hhd. of 4 eligible for the National School Lunch Program
Adoption	SA SpeakUp	67-100K (10-15% of HHDs)	<ul style="list-style-type: none"> Reported not having internet service because of data & privacy concerns or chose not to²

2. Survey asked if residents had access to the internet. 20% reported a lack of access. The survey then asked those without access "why". 1. 51% of respondents without access said they had security or privacy concerns; 49% of respondents without access said it was because they chose not to. Assumed 0-50% overlap

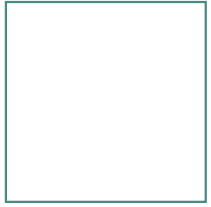

Comparison city research and local efforts

Key themes from affordable housing

Preliminary

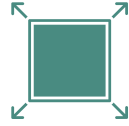

Majority of successful public housing internet access projects occur in waves, starting with specific developments and building out

- *San Francisco's initial attempt to connect all city residents in 2018 failed due to high price tag of \$1.9B*



One strategy has been to team with prominent ISPs to provide free internet for limited time, then move to discounted rates going forward

- *Los Angeles teamed with provider Starry Connect, who promised 6 months of free internet for four prominent public housing developments, then would move to a discounted pricing plan*



Public housing internet initiatives are often coupled with public school initiatives to make sure students have ability to learn remotely

- *Tulsa invested \$5.6M in providing high-speed Wi-Fi to Tulsa Housing Authority complexes and free internet to 20,000 public school families for next year*



Important to also provide digital literacy programs so residents know how to navigate the internet given their new access

- *Chicago and Comcast partnered to not only provide affordable internet to public housing, but also to hold digital literacy lessons at public libraries*

Other city examples: Affordable housing (I/II)

City / County	Stakeholders	Date	How its funded	Why did they do it	Description of actions
Chicago	Chicago Housing Authority, Comcast	2016, Expanded 2019	<ul style="list-style-type: none"> Comcast investing over \$280M in this in other initiatives Users still pay \$9.95 / month 		<ul style="list-style-type: none"> Allowed all HUD-assisted homes (public housing etc) can participate in Comcast's "Internet Essentials" affordable program for low-income families Also will provide digital literacy training at CHI public library Internet Essentials also provided 47K+ subsidized computers for under \$150
Los Angeles	Mayor's Office of Budget and Innovation, Housing Authority of LA, Starry internet, Microsoft	October 2020	<ul style="list-style-type: none"> Starry connect is paying for much of it, with help from Microsoft partnership Unclear how much Mayors office and HACLA are contributing 	<ul style="list-style-type: none"> Internet access is now a necessity specifically with COVID and remote work and learning 	<ul style="list-style-type: none"> Will deliver 6 months of free internet access to residents in four public housing communities (~9K residents) After initial phase, service will continue for \$15/month
San Francisco	City of SF Department of Technology, Mayor office of Housing and Development, Monkeybrains (internet provider)	August 2019	<ul style="list-style-type: none"> Mini grants from the Age Strong Commission and Department of Innovation and Technology (250K total) 	<ul style="list-style-type: none"> One in eight residents lack high speed internet One in seven lack basic digital literacy 	<ul style="list-style-type: none"> Launched "Fiber to Housing" program, providing 1,500 low-income families with access to free-high speed internet Leverages existing municipal fiber resources staff expertise and private sector partnerships (MonkeyBrains)
New York	NYCHA, 5 internet vendors	May 2021	<ul style="list-style-type: none"> Five vendors will charge reduced monthly servicing costs to ten developments Three developments will get for free 	<ul style="list-style-type: none"> To end the digital divide that has become more apparent during Covid-19 pandemic 	<ul style="list-style-type: none"> City executed license agreements with five internet service providers Plan to offer free and low cost high speed broadband to up to 30K residents in NYCHA housing developments

Source: <https://www.thecha.org/news-media/news/comcast-and-chicago-housing-authority-collaborate-close-digital-divide-91000-hud>
https://www.chicago.gov/city/en/depts/mayor/press_room/press_releases/2019/august/ComcastExpansion.html; <https://www.lamayor.org/mayor-garcetti-announces-free-internet-access-residents-four-public-housing-communities>; <https://www1.nyc.gov/office-of-the-mayor/news/338-21/recovery-all-us-new-york-city-free-low-cost-broadband-access-13-nycha>;
<https://sfmayor.org/article/san-francisco-fiber-housing-program-provides-internet-low-income-families>

Other city examples: Affordable housing (II/II)

City / County	Stakeholders	Date	How its funded	Why did they do it	Description of actions
Tulsa	Governor, Mayor, Tulsa public schools, Impact Tulsa	April 2020	<ul style="list-style-type: none"> \$5.6 of State of Oklahoma's allocation of COVID relief funds 	<ul style="list-style-type: none"> 15% of Tulsa families have no internet access at home 1 in 3 households don't have broadband needed for virtual learning 	<ul style="list-style-type: none"> Internet access funding has three focuses \$2.7M will provide high-speed reliable to Tulsa Housing Authority complexes, partnership with Cox to provide free internet for 3 years \$2.4M for internet access to 20K public school families \$500K will fund internet access navigators thru non-profits
Washington DC	DC Office of CTO, DC public schools, Office of State Superintendent	October 2020	<ul style="list-style-type: none"> \$3.3M of federal Cares act money 	<ul style="list-style-type: none"> Critical for families to stay connected in virtual school term 	<ul style="list-style-type: none"> 2 options One year of Comcast internet essentials paid for by DC Government if you have PK-12th grade student Up to \$50/month subsidy on internet, and one-time discount of up to \$100 for laptop
San Jose	City of San Jose, California Emerging Tech Fund, Philanthropic donors	February 2019	<ul style="list-style-type: none"> \$24M funding, \$14M from public -private partnership with telecom companies, \$10M from philanthropic donors 	<ul style="list-style-type: none"> Despite being near Silicon valley, large portions of San Jose lack fast internet needed to get jobs or succeed in school 	<ul style="list-style-type: none"> Bring broadband access to 50,000 low income housing over next decade Teach residents necessary digital skills to stay ahead and increase quality of life

Source: <https://www.cityoftulsa.org/press-room/officials-announce-internet-access-plan-for-tulsa-upcoming-programs-aimed-to-help-tulsans-impacted-by-covid-19/>; <https://www.techtogetherdc.com/internetforall/>; <https://www.mercurynews.com/2019/02/12/san-jose-set-to-launch-new-fund-to-bring-home-internet-to-thousands-of-residents/>

Overview of current SAHA efforts to expand Wi-Fi coverage

SAHA is in the process of expanding public access Wi-Fi to all their properties, focusing first on their “Big 3” campuses on the Westside covering a total of 9k residents at speeds ranging from 50 to 100 Mbps



Progress achieved

SAHA has allocated \$4M for the project through a combination of multiple sources, including:

- City funding
- Federal funding via HUD(i.e., HUD)
- Prize winnings from an innovation competition featuring SAHA's unique solar mesh Wi-Fi network

SAHA has formed effective partnerships with Grande and Spectrum, who have been willing to engage to meet needs of low-income during the pandemic

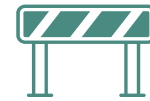

Ongoing challenges

The permitting process has slowed the desired pace up deployment for Wi-Fi network to other campuses

Infrastructure investment required goes beyond solely broadband infrastructure and includes renovations to buildings, many of which have outdated electrical wiring precluding long-term broadband solutions

Sustainability requires stable funding, which is not yet in place for the scope of work SAHA hopes to accomplish

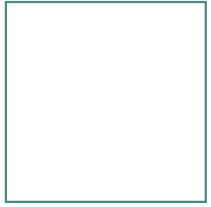

Recommendation

2

Affordable housing solutions

Detailed recommendations

- 2A **Determine required infrastructure upgrades needed to ensure wi-fi access for affordable housing**
 - Offer open public access internet to public housing campuses, including upgrades to older properties (e.g., modern electrical circuitry)
 - Establish other mechanisms to offer lower cost internet (e.g., subsidies, bulk device procurement) for individual household subscriptions
 - Utilize financial and policy levers to incentivize ISPs to participate in deployment (e.g., grants, cost sharing, demand aggregation)
 - Identify both current (e.g., ARPA, CARES) and ongoing (e.g., HUD) funding available to support public housing deployments

- 2B **Partner with other organizations to support residents across the full range of digital access needs (i.e., devices, digital literacy, adoption)**
 - Expand existing partnerships (e.g., Bibliotech, ConnectHome, Goodwill) to create shared pool of community resources that can drive adoption and increase digital literacy / skills support
 - Leverage housing community network to facilitate information sharing among organizations and device procurement for residents

Table of contents

3	Fact-base
4	Summary
6	Interviews and Community Engagement
19	Inventory Survey
28	K-12 Questionnaire
33	Size and Nature of the Digital Divide
47	ISP Economics & Engagement
56	Initiative Details
57	Infrastructure
93	Affordable Housing Access
104	Education Sponsored
127	Low-income Internet
149	Device Support
162	Adoption Support
191	Data & Analytics
214	Operating Model
244	Population Segments
250	Implementation Roadmap
273	Funding Databases
290	Asset Maps
291	Access Maps
294	Coverage Maps
300	Community Level Maps

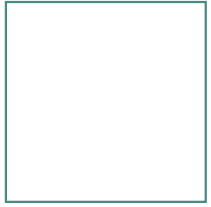

Nature of the problem

Summary | Overview of the devices & connectivity education landscape in SA / Bexar County



Bexar County contains **15 ISDs and 33 charter schools** which operate independently



ESC20 is a regional education agency that has conducted aggregated procurement and laid fiber to connect students at home



The **Texas Education Agency's Operation Connectivity** works to close the statewide K-12 digital divide by leveraging federal programs (e.g., CARES, ECF) and negotiating affordable pricing with ISPs



School districts have been successful in **distributing hotspots and devices and extending school Wi-Fi** but have found getting devices returned and offering effective tech support to be challenging



Moving forward, education efforts can focus on centralized **device management**, better **student needs data**, additional support **staffing / training**, and expansion of **digital curriculum**

Several initiatives pursued to address the broadband internet and device needs of their students



Broadband Internet

- **Hotspot distribution for at-home internet**, some with no data caps
- **Public access Wi-Fi** (e.g., parking lots, parks, school premises)



Devices

- **Chromebook / tablet** lending for use away from school
- **1:1 student to device ratio** in nearly all schools



Digital Literacy

- **Hotlines** for tech support
- Video **digital tutorials** for parents and students
- **Professional development sessions** with parents and staff

Preliminary

Device and connectivity solutions have varied across Bexar County ISDs



ISD	Students	Connectivity %	Connectivity Status	Devices %	Devices Status	Funding Sources
Northeast	64,215	Unknown	✓	Unknown	✓	State / Federal grants
Harlandale	12,444	40%	✓	90%	✓	ESSER, E-Rate, State / Federal grants
Southside	5,000	30%	✓	15%	✓	ESSER, State / Federal grants
Alamo Heights	4,917	2%	✓	1%	✓	Philanthropy, School budget
Brooks Academy	3,043	26%	✓	72%	✓	Philanthropy, State / Federal grants
Ft. Sam Houston	1,667	0.3%	✓	0%		School budget
Eleanor Kolitz Hebrew Lang. Academy	467	2%	✓	2%	✓	E-Rate, Philanthropy
Promesa Academy	180	17%	✓	89%	✓	School budget

Key learnings from school connectivity and device distribution efforts

While there have been many learnings and successes....

- “ *"The pandemic created a sense of urgency around getting students connected and got a lot of buy-in"*
- "We're really proud of having gotten to 1:1 devices for all out students"*
- "Teachers have responded well to being pushed out of their comfort zone and adapting to the situation"*
- "A lot of students have thrived under remote learning. We're hoping to keep offering that going forward"*

...There have also been challenges

- “ *"Getting devices back at the end of the year has been an ongoing issue"*
- "The loss rate for devices is much higher than usual, from 5% to 20%"*
- "Offering 24/7 tech support to students and parents through the hotline has really strained our staff"*
- "We still don't have bilingual tech support for families, which might be leaving some people out"*

Identified areas for continued support



Additional devices to account for high loss rate



Centralized device management



Better data on student need (i.e., who needs access, where they are)



Additional staffing to support bilingual tech and digital literacy support

Areas for ongoing K-12 investment in digital

- 1 Maintaining digital curriculums
- 2 Exploring remote / in-person hybrid models
- 3 Planning more robust technology training sessions

TEA is coordinating state programming and funding for student access

Since March 2020, Operation Connectivity, directed by Governor Greg Abbott, TEA, and Dallas ISD, has worked to close the K-12 digital divide

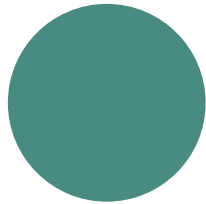

Phase 1: Historical triage using CARES funding

- Identified **\$600M+** in funding across Tech & Instructional Materials Allotment, and COVID relief funds (CARES Act)
- Developed a procurement strategy and negotiated with ISPs to secure a **20-40% discount**, closing the full device gap and ~35% of the internet gap

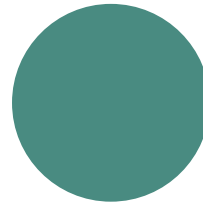

Phase II: Expansion of affordable access through contracting

- **Negotiating with ISPs** to get uniform low pricing on broadband service for students and families
- **Partnering with districts** to deliver hotspots to disconnected students to provide at-home broadband

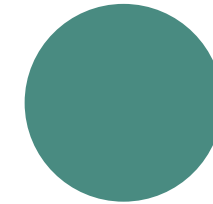

Phase III: Piloting and funding of emerging tech

- Launched RFO for traditional and **innovative technologies**, including radio wave and private LTE networks, to expand infrastructure for the 350K students without a broadband hook-up
- Considering allocating a portion of **\$12B of March 2021 ARP funding** to cover connectivity efforts

Stay up to date on program developments; use the affordable rates that are negotiated, and advocate for the education needs of COSA/Bexar ISDs

Three distinct pilots underway, with Texas A&M SA providing support and evaluation across pilots



CBTC (COSA)

Leveraging existing ISD / COSANet network offer in-home connection via WiFi; current focus on 13K students in SAISD, Edgewood, and Harlandale



CBTC (City Education Partners)

Building a private LTE network on Edgewood's 10 gig circuit and small cells to offer in-home connection via routers



BiblioTech Connect Pilot (County)

Deploying a private LTE network with small cells on water towers to extend wireless service to homes for 100 Southwest ISD students



Evaluation / help desk (Texas A&M SA)

Providing continuous evaluation of pilots through data collection, interviews, and household surveys; piloting a help desk model to support digital adoption / skills

Backup | CBTC offers model to get households from 'none-to-some'



- No data caps vs. ISP hotspot programs
- More cost effective (\$8/mo cost vs. \$50/mo ISP rack-rate)
- Addresses both availability and affordability



Limitations

- Lower avg speeds (15/1 mbps for City pilots; 25-50 mbps for CEP pilot) better for individual usage
- Localized deployment limits capacity, capacity management (e.g., on libraries, fire houses)
- Potential municipal headwinds expanding beyond students

CBTC offers model to get households from 'none-to-some', extending coverage where none exists and offering services at an affordable rate (vs. existing options)

Learnings

Engage the community, district to support adoption and offer 1:1 support

Assess efforts for ROI

- *CEP pilot*: \$325K investment for 800 students (\$400/student)
- *COSA pilot*: \$27M for ~13K students (\$2K/student)

Consider structural aspects of deployment (e.g., 120 ft tower has the strongest coverage, able to cut through tree canopy)

Backup | Progress update on CBTC rollout

	SAISD	Edgewood ISD (COSA)	Harlendale ISD	Edgewood ISD (CEP)
Fiber source	COSAnet	ISD fiber		ISD fiber (Conterra Networks)
Deployment	4 posts (fire station, radio tower, 2 libraries) - <i>limited capacity / capacity mgmt.</i>	Point-to-multi-point from school to home		
Current state	<p>Launched</p> <ul style="list-style-type: none"> Launched once SAISD could fund PMO Slow adoption due to recent school breaks, awareness building on benefit vs. hotspots, manual sign-up process 	<p>Completed site assessments; awaiting approval to build</p>		<p>Launched</p> <ul style="list-style-type: none"> Live at 4 sites with only 12 students connected Manual outreach processes has slowed adoption
Target reach	<ul style="list-style-type: none"> 3 neighborhoods 9K target students 	<ul style="list-style-type: none"> 3.2K students 	<ul style="list-style-type: none"> 2 neighborhoods 800 students 	<ul style="list-style-type: none"> 800 students

Currently capacity constrained to 1.2K students

ISD using own funds to extend access to full district

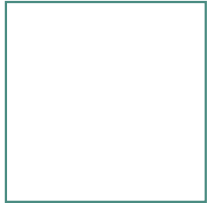

Comparison city research and local efforts

E-Rate funding provides a successful foundation...

E-Rate has successfully provided internet to eligible schools and libraries since 1996

E-rate set up for schools and libraries to flexibly use funds to improve their internet services

Eligible institutions receive discounts from 20% to 90% based on respective level of poverty

Funding requires a competitive bidding process that brings providers to the table

In 2014, the FCC modernized E-Rate to keep up with tech advancement by allowing for broadband reimbursement

E-Rate uses two categories: category 1 for data transmission and internet access, category 2 for infrastructural costs

E-Rate has helped connect 99% of America's K-12 public school and libraries to the internet

...on which to build a sustainable in-home connectivity program

Momentum exists across stakeholders to expand E-Rate funding to include in-home internet



82% of schools and libraries agree that E-Rate is the best solution to support remote learning



38 Senate Democrats wrote a letter to the FCC to include in-home internet in E-Rate language



To support in-home connectivity, E-Rate must evolve its requisite usage definitions and prioritization criteria to:



Cover in-home internet and/or 1:1 devices



Increase funding to cover disconnected students through appropriation or USF expansion



Enable schools to effectively distribute solutions

The K-12 Bridge to Broadband Initiative helps school districts to identify & purchase service for low-income families through regional / national ISPs

National broadband associations¹ and EducationSuperHighway (ESH) formed a partnership to help identify and serve low-income families that lack connectivity

- Built on the recent success of partnerships between school districts and ISPs in Chicago, Atlanta, Philadelphia, Las Vegas, among others
- The program establishes a national framework for broadband providers to work with school districts to identify and connect low-income families through low-cost (e.g., \$10/month) sponsored service agreements paid by the district

The partnership focuses on delivering equitable service through five core pillars to ensure benefit to families in need

- **Sponsor service:** companies create a "sponsored" service offering for districts
- **Identify student need:** companies will work with districts to identify students who need service based on their coverage maps
- **Standardize eligibility:** a baseline set of eligibility standards will be used across the board
- **Facilitate enrollment:** companies will sign families up using minimal personal information
- **Protect privacy:** companies will not target families for marketing if they are covered by the program

Participating internet service providers are positioned to have a significant impact in bridging the digital divide

- Dozens of ISPs have agreed to support this program including Comcast, Charter, Cox, GCI, Mediacom, Midco, Sjoberg's and Vyve; These providers offer broadband service to 80% of U.S. homes (110M households)
- ISPs were willing to join the initiative for near-term PR and longer-term strategic benefits of an expanded consumer base

1. NCTA - The Internet & Television Association, The Rural Broadband Association, USTelecom
Source: Press Releases

Los Angeles Unified School District led efficient procurement and unlocked emergency bond funds to quickly narrow the short-term divide

The LAUSD Superintendent took swift action to close the digital divide, ahead of state-led guidance

- The school board gave the Superintendent authority to address the crisis, centralizing leadership and accelerating the process
- LAUSD ran a rapid procurement process, recognizing there may be supply chain constraints akin to the earlier PPE supply constraints
- LAUSD received a voter-approved, property tax fund \$78M bond authorization, the outcome of 10-year authorization effort

LAUSD distributed devices and hotspots to families through schools, enabling 90% of students to engage in online classes

- Estimated that ~150K students (~25%-35% of the district's 470K K-12 students) were on the wrong side of the digital divide in 2019
- Purchased 185K devices and 200K LTE-enabled iPads/hotspots, largely through a Verizon partnership, supplementing existing 1:1 efforts
- Streamlined distribution process with socially distant pick-ups at schools and no required documentation for eligibility
- Stood-up dedicated IT help desk to assist students logging on, significantly expanding support as school went online

LAUSD recognizes the need for continuing support to ensure ongoing sustainability of device and connectivity efforts, including:

- Developing rigorous use standards to ensure that connectivity is sufficient to enable distanced learning for the entire family
- Identifying additional sources of funding, beyond school budgets, to cover universal access and support costs (e.g. administrative costs, tech support desks)
- Continuing and expanding requisite purchasing, including planning for ongoing repairs / replacements and offering devices to a broader base of students (e.g., including pre-K students)
- Addressing teacher connectivity issues and supporting teachers to effectively teach remotely

Active community leaders in Chattanooga leveraged existing fiber networks to provide high quality, sustainably funded internet

The Enterprise Center brought the appropriate stakeholders to the table to help bridge the digital divide in Hamilton County

- As an economic development partner with a focus on digital equity, the Enterprise center was suited to conduct the connection initiative
- Experts were brought together across the municipal, private sector, and school district to strategically tackle the issue
- EPB served as the key provider and increased adoption of Wi-Fi for students thank to an already built, sophisticated fiber network infrastructure

Identification of students in need and outreach to increase adoption were thoroughly done to support as many families as possible

- While eligibility includes all students under the Free or Reduced Lunch Program (FRLP), about two-third of students, schools helped identify additional underserved populations who required connectivity (e.g. homeless, undocumented, refugee)
- Ensuring trust was the focus of the adoption strategy with established community organizations spreading the word, multilingual pamphlets provided to families, and door to door outreach
- Emphasis is placed on call center and scheduling service quality as well as continued improvements to adoption efforts
- Families receive high-speed fiber service which is far stronger than standard connection and better suited for the virtual learning environment

A sustainable funding model was created by improving the cost model and fundraising through local partners

- By centralizing connectivity through a single payer, costs were greatly lowered with EPB only paying the cost of service without upcharge
- Over \$6M raised to fund the effort across a combination of private sector, district, and philanthropic donors; \$8.2M needed to fund 10-year plan
- Households must re-qualify for the program each year to receive this free, high-speed internet service

Key themes from digital curriculum

Preliminary



Most programs rely on the distribution of hardware such as laptops as the basic pillar for their digital offering

- *Irving Independent School District in Dallas re-allocated resources from vast number of unused books to finance laptops for all students in grades 9-12 and netbooks for middle school students for in-school use*



Some schools extend hardware roll-out to re-design learning spaces for interactive, digital-enabled in-school learning experiences

- *Tampa Preparatory School created IDEA lab where environment is a learning mechanism itself with multiple touch-enabled projectors transforming walls into interactive presentation spaces*



Across the board, schools are moving away from textbook education and digitizing both materials and grading for more relevant, personalized and lower cost education

- *New Tech High School in Napa adopted online grade books that show students performance in each course, as well as learning outcomes averaged across all courses, with "electronic learning portfolios" sampling students' work*



Schools are experimenting with blended and fully virtual learning to reduce per-student cost and increase access

- *Michigan's Walled Lake School District developed an online summer school credit recovery program which reduced cost by 57% per student and started offering online learning opportunities during the semester*

Other city examples: Digital curriculum (I/II)

City / County	Stakeholders	Date	How its funded	Why did they do it	Description of actions
Seattle	Kent School District	2005	Kent 1:1 laptop program; Kent Phoenix Virtual Academy	<ul style="list-style-type: none"> Address equity issues in diverse district, reduce school drop out rate and cost 	<ul style="list-style-type: none"> 1:1 computing program serving 9,000 students Moving away from textbooks allowing teachers to pull more recent resources from the web (goal to have all textbooks available digitally) Virtual programs designed to teach students to think more critically and demonstrate understanding in other ways than just paper and pencil tests - e.g., create a movie, blog or wiki, animation or game, etc.
Tampa	Tampa Preparatory School	2017	IDEA lab (Innovate Design Explore Apply)	<ul style="list-style-type: none"> To create a flexible learning environment 	<ul style="list-style-type: none"> Classrooms equipped with innovative technologies and ergonomic furniture with mobility of bumper cars to create "Active Learning Environments" (ALEs) Moving towards "Expositional Centers of Learning" where teachers and textbook content are no longer the sole source of learning - environment is a learning mechanism itself (multiple touch-enabled projectors transforming walls into interactive presentation spaces) Student-initiated programming & VR curriculum, clubs, etc.
Cumming, GA	Forsyth County Public Schools	2016	Bring Your Own Technology Program	<ul style="list-style-type: none"> To increase student engagement and outcomes 	<ul style="list-style-type: none"> Students are allowed to choose the tools they want and need to direct their own learning Students choose both hardware and software tools, preparing them to arrive with the job skill of adapting how they're individually using technology in a greater environment saturated with tech
Campbell, Wyoming	Campbell County Virtual School	n/a	Public K-6 online school	<ul style="list-style-type: none"> n/a 	<ul style="list-style-type: none"> Families of enrolled students are loaned computer and receive subsidized Internet access and materials incl. CDs, videos, instructional materials and tools to complete interactive online elements of program

Source: <https://www.ed.gov/oii-news/use-technology-teaching-and-learning>, <https://www.k12blueprint.com/sites/default/files/Case-Study-Kent-SD.pdf>, <https://thelearningcounsel.com/article/12-school-districts-honored-their-innovative-digital-curriculum-transition-strategies>, <https://tampaprep.org/learn/innovative-spaces/>

Other city examples: Digital curriculum (II/II)

City / County	Stakeholders	Date	How its funded	Why did they do it	Description of actions
Dallas	Irving Independent School District	2014	1:1 laptop implementation	<ul style="list-style-type: none"> • Reallocate resources (unused textbooks to laptops) 	<ul style="list-style-type: none"> • Replacing textbooks with computerized versions of texts (146K unused textbooks in warehouse equivalent to 15K new laptop computers) • Faculty shifting from textbook learning to wide array of digital curriculum • Laptops for all students in grade 9-12 to take home, netbook computers available for all middle school students during school day
Bay Area, Milwaukee, Nashville, Washington D.C.	Rocketship Education	2006	Chain of free, public K-5 college prep K-5 charter schools	<ul style="list-style-type: none"> • Catalyze transformative change in low-income communities through scalable and sustainable public school model 	<ul style="list-style-type: none"> • Elementary charter school network with hybrid model: students attend Learning Lab using computers, which doesn't require presence of certified teachers who are engaged in planning while students are in Lab • Rocketship reinvests savings in training, response to intervention, higher teacher salaries, facilities and academic deans
Mooresville, NC	Mooresville Graded School District	2006	Digital Conversion Initiative	<ul style="list-style-type: none"> • Promote use of technology to improve teaching and learning 	<ul style="list-style-type: none"> • Use of laptop computers and other technologies as instructional tools • Shift to digital textbooks
Napa, California	New Tech Network / New Technology High School	2008	Online grade books	<ul style="list-style-type: none"> • Inspire students to be responsible, resilient, and personally successful in the rapidly changing 21st century 	<ul style="list-style-type: none"> • Student work is assessed, and feedback is made available to students via online grade books that are continually updated so that students can see how they are doing in each course, but also on each of their learning outcomes averaged across all courses • Electronic learning portfolios contain examples of students' work

Source: <https://www.ed.gov/oii-news/use-technology-teaching-and-learning>, <https://www.k12blueprint.com/sites/default/files/Case-Study-Kent-SD.pdf>, <https://thelearningcounsel.com/article/12-school-districts-honored-their-innovative-digital-curriculum-transition-strategies>, <https://tampaprep.org/learn/innovative-spaces/>

Indianapolis used state grants and led district execution in a decentralized model that bridged local digital divides

The state of Indiana deployed GEER funds to help close the digital divide through a needs-based, competitive grant program

- Rather than distributing funding to states using a formula, grants applications allow districts to express their relative need for funds
- The grant program forced districts to think strategically around how funds would be invested and gave them choice in how to bridge their divide
- Grant money could be spent by the district to improve device availability, connectivity, and educator capacity

Grant requests were reviewed by the state for quality and overall need to inform the amount to be funded

- District grant requests were rubric evaluated across demonstration of needs, quality of execution plan (including sustainability), evidence of efficient budget usage, and definition of performance benchmarks with district equity and existing technological infrastructure also considered
- Quality assurance was employed to ensure that districts were allocating reasonable costs per line item and requesting an appropriate number of devices based on past student survey results
- High request volumes led to \$1 of funds provided for each ~\$3-4 dollars requested, partially due to some unreasonably high requests
- Stranded investment opportunities, initiatives that could not be funded, were pointed to other state departments and philanthropy funds

Districts led provisioning of devices and connectivity, with Indianapolis finding success through effective collaboration

- Districts who receive funding have full jurisdiction over the services they purchase and distribute to students in need
- Indianapolis public schools created an 11 district coalition (~10% of students) to increase purchasing power during procurement
- A group of Indianapolis-area philanthropies raised \$2.6 million to help Indianapolis schools narrow the divide with devices and hotspots
- Organized RFP for connectivity, ultimately partnering with T-Mobile for 2 years, with districts driving procurement and distribution; request for hotspots from schools has dropped from 38K in the Spring when the pandemic first hit to 21K in the Fall
- Participated in statewide grant program, receiving ~20% of available funds to be distributed to districts to continue narrowing the divide



Recommendation

3

Education sponsored solutions

Detailed recommendations

Preliminary

- 3A Standup school-centric connectivity and device programs, including sponsored service programs and 1:1 models**
 - Encourage schools to maximize E-Rate to ensure high quality, reliable internet in schools and leverage funds that support remote learning (e.g., ECF)
 - Support 1:1 device / hotspot programs made possible by bulk purchasing, ISP student rates, and gov. support (e.g., Operation Connectivity, relief funds)
 - Set up service contracts with providers, extending existing relationships where possible, to cover the cost of new devices, replacements, and repairs

- 3B Elevate schools as a locus for adoption support of available low-cost programs**
 - Conduct data assessments to understand the existing needs of their students
 - Support information sharing and adoption around available low-income programs (e.g., EBB, Lifeline), supporting cost of service if possible
 - Standup help desks (e.g., through IT depts) to troubleshoot software issues, support program enrollment, and help families navigate once connected

- 3C Build digital skills leveling into the backbone of learning, boosting digital literacy across grade levels**
 - Embed digital standards into curriculum and upskill teachers so that they can provide basic digital instruction to students
 - Invest in supportive resources to help students learn virtually (e.g., online digital literacy courses, digital resource centers)

- 3D Expand capacity to support cross-school and cross-district efforts through hiring and aggregated procurement / service delivery**
 - Standup district-wide help desks to troubleshoot issues faced by students
 - Engage in consortium purchasing to maximize volume discounts, share the execution burden, and increase ISP engagement

Overview of the FCC's ~\$7B Emergency Connectivity Fund to be distributed through the E-Rate mechanism

First window of applications will apply for *purchases for the coming school year* (July 1, 2021 - June 30, 2022) with a second window to *reimburse past invoices* since the beginning of school closures (March 1, 2020 - June 30, 2021)¹



Who is eligible?

All E-Rate eligible **K-12 schools, libraries, and consortia** who made purchases to meet the **remote learning needs** (e.g., in-home Wi-Fi, loanable devices) of students, staff, and library patrons

E-Rate excludes **for-profit schools and schools with endowments** valued at over \$50M



What can be purchased?

Reasonable support amounts in line with typical solution costs:

- \$400 reimbursement for devices
- \$250 reimbursement for hotspot
- \$10-\$25 monthly internet service
- Cost of modems & routers (amount under USAC discretion)

Schools / libraries can **fully cover** (vs. the 20-90% E-Rate discount) device and service **purchases that support remote learning**, excluding the purchase of mobile phones or the building of new networks²



How do I apply?

Schools and libraries will apply using the **existing E-Rate application**

Schools must certify that they are only seeking support for students / staff who would otherwise lack devices or broadband sufficient to engage in remote learning

Libraries must provide patrons with **eligible use policies moving forward**, which explains that equipment is for those without access to services sufficient for educational needs

Operation Connectivity has stood up a program to support all Texas ISDs through the ECF application

1. If it appears that demand far exceeds supply in the initial window, the FCC may open a second “prospective” window for the coming school year before opening an application window for reimbursements; 2. Network construction is eligible only if no commercially available Internet access service for purchase is available to reach students, school staff, and library patrons in their homes

Table of contents

3	Fact-base
4	Summary
6	Interviews and Community Engagement
19	Inventory Survey
28	K-12 Questionnaire
33	Size and Nature of the Digital Divide
47	ISP Economics & Engagement
56	Initiative Details
57	Infrastructure
93	Affordable Housing Access
104	Education Sponsored
127	Low-income Internet
149	Device Support
162	Adoption Support
191	Data & Analytics
214	Operating Model
244	Population Segments
250	Implementation Roadmap
273	Funding Databases
290	Asset Maps
291	Access Maps
294	Coverage Maps
300	Community Level Maps

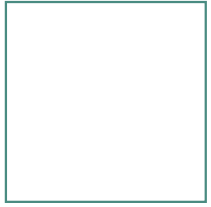

Nature of the problem

Summary | Overview of the affordability barriers faced by SA / Bexar County



An estimated **90K Bexar County households** (~70% of disconnected households) face affordability barriers, reporting that they cannot afford the monthly internet bill



Studies show that \$60K income is the threshold at which the digital skills gap shrinks and the **median household income in Bexar County is \$54K**



Preexisting **socioeconomic challenges and systematic social exclusion** continue to leave marginalized communities out of digital opportunities and resources

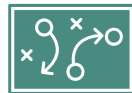

Addressing affordability requires a **segmented approach by population** that leverages both existing government programs and launches new low-cost internet programs

San Antonio and Bexar households face a significant digital divide...



20%+ (130K+) of San Antonio / Bexar households lack access to broadband



...With significant differences across districts, e.g.,

- District 5: 38% lack access
- District 9: 6% lack access



10%+ (65K+) of San Antonio/Bexar households lack access to devices

...Driven by several factors

Reasons for not using internet (% of respondents)

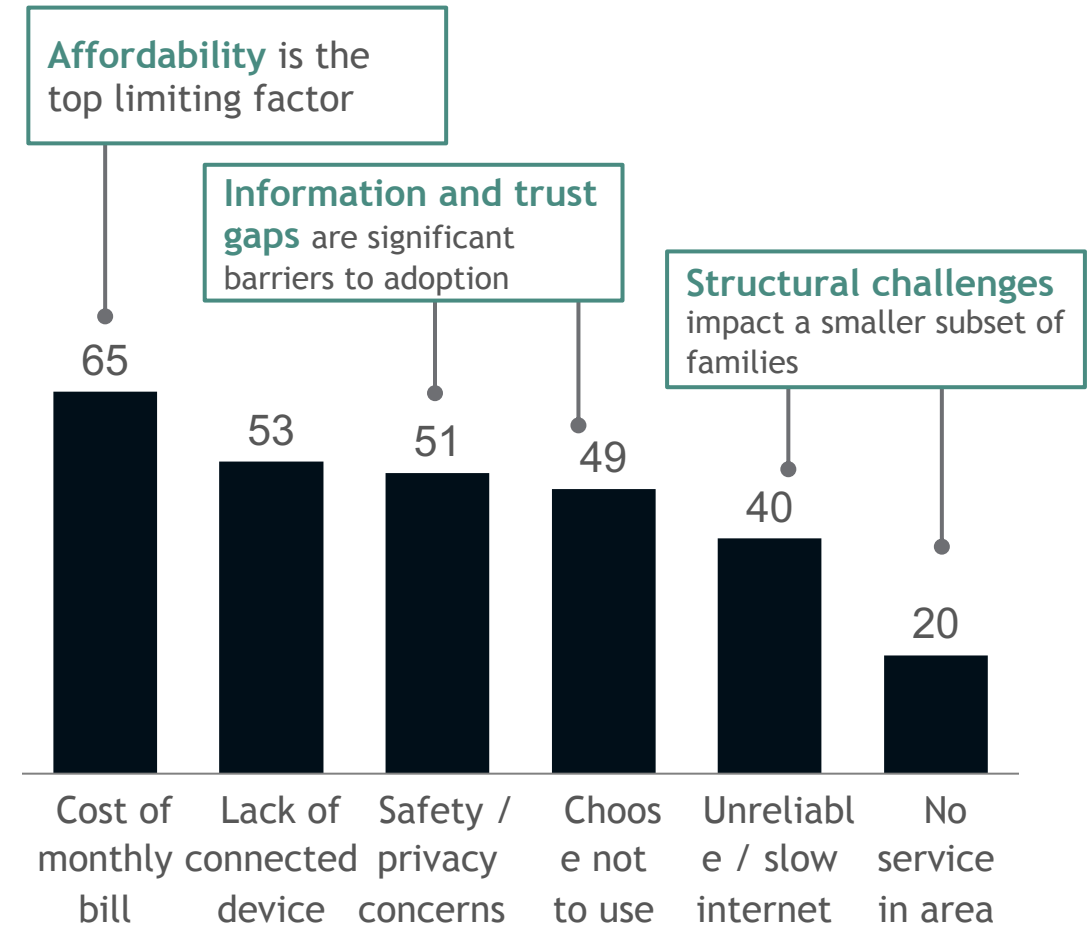

Current assessment of the size and nature of the digital divide in SA / Bexar by number of households

Size of the divide



Households (20%+ of all hhds.) without adequate broadband access



Households (10%+ of all hhds.) without connected devices

Barriers to adoption



Availability

50K

Households (40% of disconnected hhds.) lack access to reliable, adequate (100 mbps) coverage



Affordability

90K

Households (70% of disconnected hhds.) report not having access because they cannot afford their monthly bill



Adoption

Up to 130K

Households (up to 100% of disconnected hhds.) face adoption barriers including lack of comfort with digital tools, language barriers, etc.

Households may face more than one barrier

Affordability and adoption are the greatest barriers to access; extent of availability challenges varies by source and service quality

Category	Sources	# and % of households	Considerations
Availability: Unserved	Broadband Now	5K <i>(0.8% of HHDs)</i>	<ul style="list-style-type: none"> • Unserved by 25 mbps coverage
	SASpeakUp ¹	27K <i>(4% of HHDs)</i>	<ul style="list-style-type: none"> • Reported not having internet because there was no service in their area
Availability: Underserved	Broadband Now	9K <i>(1.4% of HHDs)</i>	<ul style="list-style-type: none"> • Unserved by 100+ mbps coverage
	SASpeakUp	53K <i>(8% of HHDs)</i>	<ul style="list-style-type: none"> • Reported not having internet because service was slow or unreliable
	Broadband Now	201K <i>(30.1% of HHDs)</i>	<ul style="list-style-type: none"> • Unserved by 1 gig coverage
Affordability	SASpeakUp	87K <i>(13% of HHDs)</i>	<ul style="list-style-type: none"> • Reported not having internet because could not afford the monthly bill
	ACS data	211K <i>(33% of HHDs)</i>	<ul style="list-style-type: none"> • % with income less than \$50K, proxy income for hhd. of 4 eligible for the National School Lunch Program
Adoption	SA SpeakUp	67-100K <i>(10-15% of HHDs)</i>	<ul style="list-style-type: none"> • Reported not having internet service because of data & privacy concerns or chose not to²

2. Survey asked if residents had access to the internet. 20% reported a lack of access. The survey then asked those without access "why". 1. 51% of respondents without access said they had security or privacy concerns; 49% of respondents without access said it was because they chose not to. Assumed 0-50% overlap

Affordability is a main barrier to access for Bexar County students & families

65%

Residents that say affordability is main barrier to internet access

\$60k

Income threshold at which digital skills gap shrinks

\$54k

Median household income in Bexar county

Broadband access by income in San Antonio/Bexar (%)

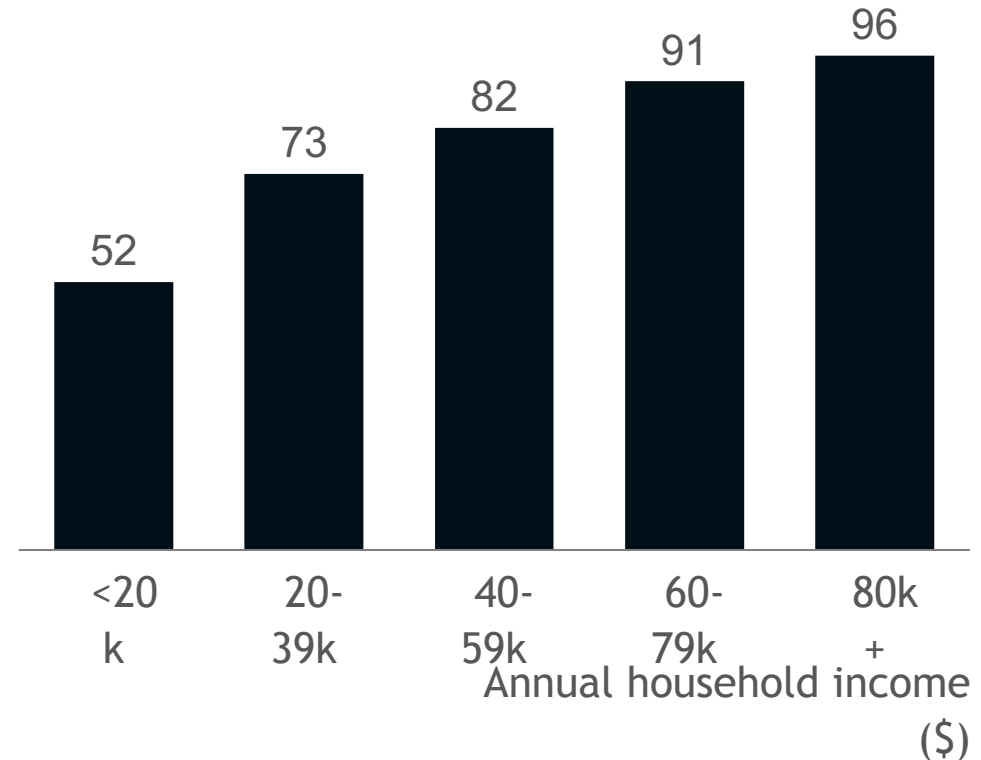

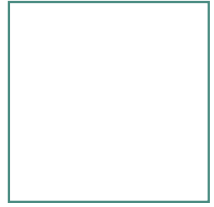

Comparison city research and local efforts

Lifeline program overview and limitations



Policy Design

- Established in 1985 to make communications services more affordable for low-income customers across the nation
- Provides monthly subsidy of \$9.25 for either a phone or internet service for qualifying low-income households (e.g., income below 135% of federal poverty line)
- Funded through the Universal Service Fund, costing \$972M in 2018
- Requires telecom companies to provide minimums of 1,000 minutes for cellphone service and 1.024 GBs of data for broadband plans
- Requires an annual renewal in which users must prove that they still qualify for the subsidy



Current Shortcomings

- Current subsidy of \$9.25 provides insufficient internet speeds, especially in households with multiple users; monthly discount of \$25-50+ likely required
- Low adoption rates due to poor outreach and marketing with only ~25% of eligible households enrolling in 2018; program would cost \$3.9B if fully utilized¹
- Many users put their Lifeline subsidy towards phone plans, leaving them without internet
- Program has faced criticism due to high levels of fraud and abuse (e.g., enrollment of deceased persons)
- Providers' offerings not universal due to lack of broadband availability

1. <https://www.attpublicpolicy.com/universal-service/understanding-the-potential-cost-of-an-expanded-lifeline-program/>

Key themes from expansion of free internet

Preliminary



Successful internet expansion programs leverage existing public infrastructures to provide access quickly at a low cost

- *Seattle launched the "Internet for All" initiative to expand free Wi-Fi across public libraries, parks & recreation community centers, and will further be exploring locations such as homeless shelters, senior living facilities, etc.*



Most large-scale expansion efforts rely on public-private partnerships between the government, nonprofits and technology companies

- *NYC partnered with a consortium of tech companies to create LinkNYC, converting phone booths across the city into Wi-Fi hotspots that generate Ad revenue*



There's a strong focus on providing access to free internet for students to enable remote learning outside of schools

- *Chicago launched program to provide 100,000 students with free internet in their households for a minimum of four years funded by the CARES Act*

Other city examples: Free internet expansion (I/II)

City / County	Stakeholders	Date	How its funded	Why did they do it	Description of actions
Portland	The City of Portland, Multnomah County	April 2016	Digital Equity Action Plan	<ul style="list-style-type: none"> Remove cost barrier to broadband adoption in order to help low-income residents get online 	<ul style="list-style-type: none"> Leverage networks shared by public institutions to extend free WiFi into low-income neighborhoods (Multnomah County Library, City of Gresham, Parkrose School District, Portland Public School District, etc.)
Seattle	City of Seattle	September 2020	Internet for All	<ul style="list-style-type: none"> Improve access in "digital equity zones" across the city 	<ul style="list-style-type: none"> Expand free or low-cost connectivity options in targeted areas of the city (e.g., Seattle Public Library, Seattle Parks & Recreation Community Centers, etc.) Conduct WiFi assessments for small businesses and community providers (homeless shelter, nutrition sites, senior living facilities and centers, etc.) Develop mapping application for public WiFi Partner with Seattle Public Schools to increase hotspot devices available for distribution to students Partner with BIPOC organizations to explore new models
New York City	City in partnership with consortium of tech companies	2012 / 2020	LinkNYC Project	<ul style="list-style-type: none"> Connect underserved residents (18% of households don't have home internet, 40% only have phone or home access, not both) 	<ul style="list-style-type: none"> Reimagine the thousands of phone booths across NYC's as Wi-Fi hotspots through public private partnership City provides sidewalk real estate and access to underground conduit in exchange for tech companies designing, installing and maintaining the terminals (operated by Google subsidiary Sidewalk Labs); revenues generated through Ads Note: only 1,800 kiosks (of planned 7,500) were installed so far to connect with nodes to form a network)
New York City	New York City	2020	NYC's Internet Master Plan	<ul style="list-style-type: none"> "" 	<ul style="list-style-type: none"> Master Plan to optimize "open access" and "neutral host" infrastructure

Other city examples: Free internet expansion (II/II)

City / County	Stakeholders	Date	How its funded	Why did they do it	Description of actions
San Jose	City of San Jose	2019	Digital Inclusion Fund	<ul style="list-style-type: none"> 1/10th of residents without home access 	<ul style="list-style-type: none"> Goal to connect 50,000 households over the next 10 years (\$24M program)
San Francisco	City and Country of San Francisco's Department of Technology, Mayor's Office of Housing and Community Development, Monkeybrains	2018	Fiber to Housing	<ul style="list-style-type: none"> To provide free, high-speed internet to low-income households by leveraging existing municipal fiber resources 	<ul style="list-style-type: none"> Leverage 170 miles of existing fiber to create the Community Broadband Network, providing wireless broadband to low-income households in partnership with non-profits Provide Wi-Fi at 38 Housing Authority sites, 24 Senior Technology Centers, and a number of non-profit run sites that serve low-income populations Free internet is delivered through fiber-optic and ethernet cabling in the affordable housing unit and through an open Wi-Fi network
Baltimore	City of Baltimore and partners	May 2020	Baltimore Digital Equity Coalition	<ul style="list-style-type: none"> Close digital divide (2 in 5 households do not have wireline internet service) 	<ul style="list-style-type: none"> Partnership between government and nonprofits, parents and teachers, foundations, school leaders E.g. Project Waves, which is providing free internet through internet access points on rooftops
Chattanooga	City of Chattanooga, Hamilton County Schools, EL. Power Board	July 2020	HCS EdConnect	<ul style="list-style-type: none"> Provide broadband access for students 	<ul style="list-style-type: none"> Provide free internet access to 17,700 households with students on the free or reduced lunch program (\$8.2M) to connect more than 32,000 students

Alabama issued state vouchers and collaborated with ISPs to unlock broad and rapid deployment of services

The Alabama Department of Economic and Community Affairs (ADECA) acted quickly to set up a broadband expansion program

- When it became apparent in July that students would not be returning to school in the Fall, ADECA quickly partnered with CTC Technology & Energy, a telecommunications contractor, to devise a statewide mechanism to roll out broadband internet quickly and efficiently
- Program aimed at low income students (~450K across Alabama), focusing on students where affordability was a barrier to adoption
- Focused on offering fixed broadband solutions where possible to remove adoption barriers due to one-time fixed costs (e.g., installation fees and equipment costs)

With strong ISP participation, a voucher program was rapidly designed and distributed to low-income families across the state

- Contracts were negotiated and signed with 38 ISPs in just 3 weeks, with state-wide pricing for service fees, installation, and equipment costs
- Qualifying families were sent vouchers with customized list of provider suggestions based on what ISPs could serve their address, but families could apply the voucher to any address; program maximized family's ability to choose their service provider
- Families with no ISP coverage were mailed hotspots; families who already had coverage were able to obtain service credit from providers
- Billing contracts were set up directly with the state, eliminating the need for families to undergo credit checks or provide billing information
- Unless families opt-out, ISPs can offer families plan options to consider when CARES funding expires at end of the year

ADECA continues to push adoption as school begins, with a variety of techniques employed to engage students

- 250K+ vouchers have already been sent with ~10% adoption after just 10 days
- ADECA promoted the program through local nonprofits, school superintendents, robocalls, social media campaigns, ISP marketing materials (within contract confines), and an ADECA ambassador center support families through the voucher process

Municipal bonds can be a mechanism to expand broadband access



Call to action for bond usage

Municipal bonds have historically been used to **finance public projects** (e.g., roads, schools)

Advocacy has grown around bond usage for digital inclusion:



TechBloc CEO, David Heard, pushed for **inclusion of digital infrastructure** in San Antonio's 2022 bond program



Forbes and Pew Trusts have advocated for the **potential of municipal fiber bonds**



Benefit of muni broadband bonds

Enables **city-sponsored digital infrastructure buildout**, akin to roadways, power, water projects

Creates **public-private partnership** between the city and ISP where residents are able to **affordably repay the investment** over time

Lowers prices and improves services through ISP competition, incentivizing strong performance for contracts renewals



Examples of municipal bonds



Salt Lake City communities combined to finance a **fiber network to homes**, allowing **all service providers** to operate to lower service costs



New Hampshire towns have issued bonds to **construct fiber networks**, funding the bond payments through **~\$10 monthly subscriber fees**

Consider municipal bond model and take necessary local steps to include proposal for City council

Texas to potentially unlock additional broadband funding through federal sources and the state budget via House Bill 5

Preliminary

Proposed elements of the House's Bill 5 Budget for 2022-2023



~\$3-4M of the state budget to go towards **administrative broadband funding** (e.g., creation of a Statewide Broadband Development Office)



Allocation of **\$100M of federal funding** towards broadband development programs



Expansion of digital programming in colleges (e.g., ~\$1M for UT Austin College of Fine Arts, ~\$1.8M for UT Permian Basin) and digital inclusion for libraries (e.g., ~\$3.75M in funding)



Provision of funding for **additional broadband projects** (e.g., ~\$550K for Monahans Broadband Project, ~\$250K for Cameron County broadband expansion)

*Advocate for state funds to be allocated to COSA / Bexar priority areas;
Identify areas where the state can play a state-wide role (vs. rural focus)*

Local Efforts: Low-income internet (I/II)

Organizations expanding internet access

- Good Samaritan Community Services
- San Anto Cultural Arts
- VIA Metropolitan Transit
- UTSA Small Business Development Center
- UT Health San Antonio
- The Children's Bereavement Center Of South Texas
- YMCA of Greater San Antonio
- Adult Years Program
- AYVP
- SAISD/AYVP/ Project SEARCH
- SAISD
- San Antonio Housing Authority
- Roy Maas Youth Alternatives
- Libraries Without Borders US
- Girls Inc. of San Antonio
- Madonna Center, Inc.
- Alamo Colleges District

Examples of how orgs have supported this initiative

- “ We offer **free internet access at our offices** and teach basic digital arts - San Anto Cultural Arts
- “ We **offer free WiFi** at all Transit Centers and ALL of our buses and VIAtrans vehicles - VIA Metropolitan Transit
- “ We have a small center with a small number of **laptops available for public use** - VIA Metropolitan Transit
- “ RMYA provides youth the use of **onsite computers to access resources, obtain documents, school work, and job applications** - Roy Maas Youth Alternatives



Local Efforts: Low-income internet (II/II)

Organizations providing low-cost internet or devices

- SAISD
- Southwind Fields
- Family Service Association of San Antonio, Inc.
- Alamo Colleges District

Examples of how orgs have supported this initiative

- “ We can provide emergency assistance to enable people to obtain or retain their broadband access - Family Service Association of San Antonio
- “ Students are eligible to purchase technology devices and hot spots at reduced rates - Alamo Colleges District



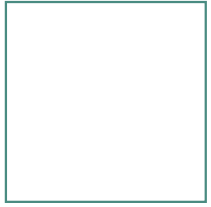

Recommendation

4

Low-income internet solutions

Detailed recommendations

Preliminary

- 4A **Partner with community organizations to connect as many residents as possible to available low-income solutions**
 - Drive awareness campaigns through trusted organizations to enroll households in low-income internet programs (e.g., Lifeline, EBB, Internet Essentials)
 - Direct residents to existing free internet and digital skills building programs in the community (e.g., OATS, libraries)

- 4B **Expand free internet to create holistic "safety net" access through the extension of public networks and opening of existing Wi-Fi hotspots to the public**
 - Work with ISPs and community organizations to create a campaign advertising their free and low-income broadband service
 - Leverage community nodes for public, internet expansion projects (e.g., public transportation, parking lots, libraries), ensuring adequate security measures
 - Standup public computer labs in the community (e.g., libraries) so that disconnected residents can access internet and find support outside the home

- 4C **Consider new programs to subsidize internet for low-income families**
 - Standup voucher program or public broadband rebates to discount service costs for eligible households
 - Leverage municipal bulk procurement (e.g., build on Operation Connectivity) or municipal bonds to increase public access to low-cost internet options

- 4D **Enforce affordability targets and advocate for increased funding to make service more affordable when engaging across stakeholders**
 - Include affordability minimums in grant criteria or for usage of municipal fiber
 - Build transparent affordability targets (e.g., benchmark across services) when negotiating pricing with ISPs
 - Partner with state governments to increase support and funding around affordable broadband initiatives

Addressing affordability requires a segmented approach by population

Illustrative, non exhaustive

Example initiatives

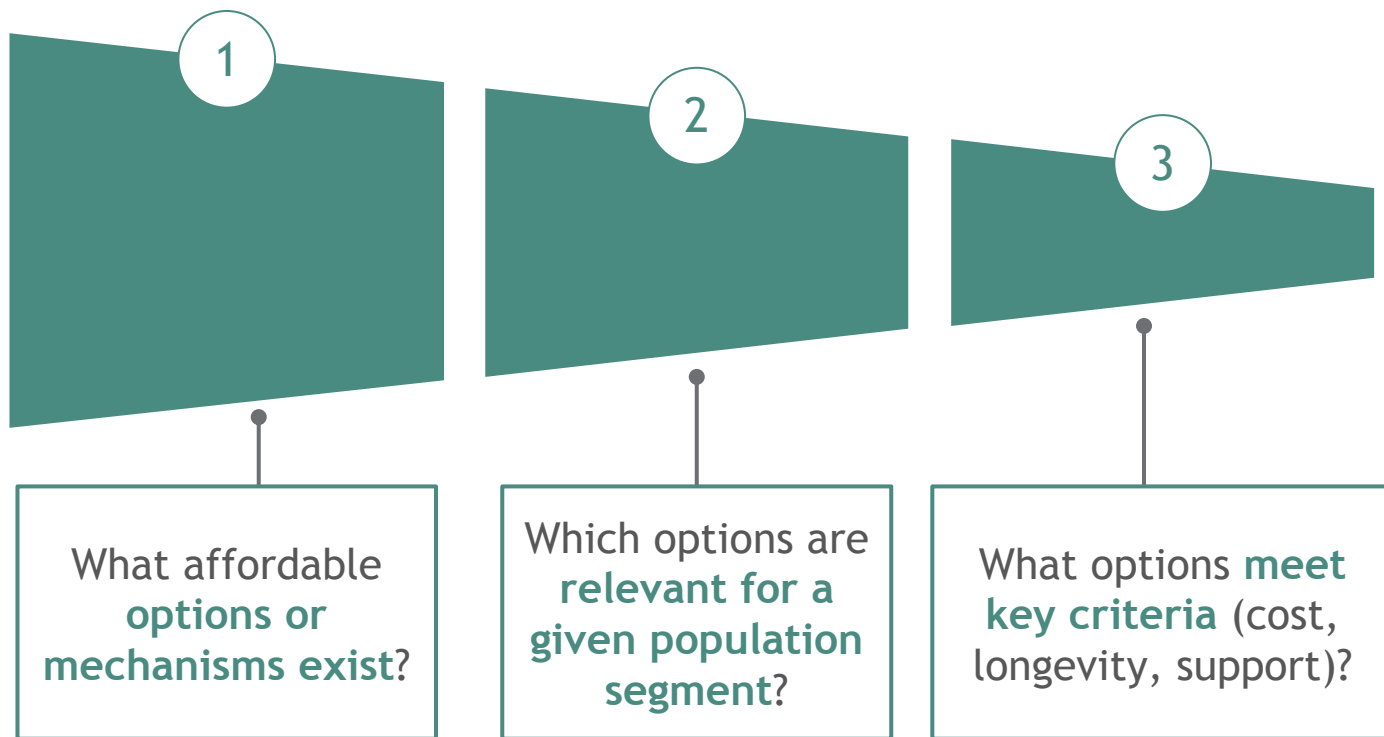

Sponsored service / E-Rate program for students

Free public WiFi for hhds in affordable housing

Adoption campaign for ISP plans for low-income hhds.

EBB/public rebate supplement for low-income hhds.

Key components of the Emergency Broadband Benefit Program (EBB) launching on Wednesday, May 12th

1 What is covered?

- Up to a \$50/month discount on broadband service and equipment rentals (\$75/month for hhds on Tribal lands)
- A one-time discount of up to \$100 for a laptop, tablet, or desktop (with co-pay of \$10 to \$50)

2 Who is offering?

- ~70 participating ISPs in Texas, including AT&T, Charter, Comcast, Frontier, Grande
- The FCC reimburses the ISPs directly, reducing the payment logistics on households

3 Who is eligible?

- Households at or below 135% federal poverty guidelines
- Households that qualify for Lifeline, participate in the free and reduced lunch program, received a Pell grant, or participate in Tribal specific programs

4 How it works?

- Households apply either online, mail-in, or through participating broadband providers
- Once approved, households choose a participating ISP
- Households will need to opt-in or request to continue services when funds run out

Note: the program is available to eligible new, prior, and existing customers; users with previous broadband debt are still allowed to participate in the program

Coordinating with the City and County to drive EBB adoption campaign



Build Awareness

- Arm community organizations (e.g., Texas A&M, SAHA), school districts, and libraries with digestible promotional materials (illustrative example on next page)
- Share EBB information through City / County channels (e.g., website, newsletter, social media)



Stand up support network

- Set up City / County call centers to support EBB enrollment process
- Partner with community orgs, schools, libraries to enroll families and direct questions to the hotline
- Upload helpful links to a City / County resource center, sharing the latest application / support information and FAQs

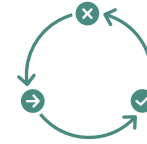

Create feedback channels

- Create channels (e.g., EOD Zoom call, Google form) for call centers, residents, ISPs to share questions, feedback, and pain points
- Incorporate feedback into refined materials / processes and expand the set of support community orgs to build a broader adoption ecosystem

A successful launch of the EBB program, coordinated by SA / Bexar, can **build trust in the community** and increase momentum behind a **supportive, digital ecosystem** of community orgs, ISDs, and philanthropies that will **organically engage disconnected households** (e.g., reveals adoption needs and key barriers faced)

Table of contents

3	Fact-base
4	Summary
6	Interviews and Community Engagement
19	Inventory Survey
28	K-12 Questionnaire
33	Size and Nature of the Digital Divide
47	ISP Economics & Engagement
56	Initiative Details
57	Infrastructure
93	Affordable Housing Access
104	Education Sponsored
127	Low-income Internet
149	Device Support
162	Adoption Support
191	Data & Analytics
214	Operating Model
244	Population Segments
250	Implementation Roadmap
273	Funding Databases
290	Asset Maps
291	Access Maps
294	Coverage Maps
300	Community Level Maps

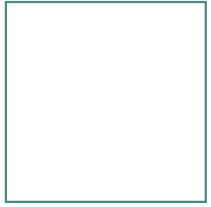

Nature of the problem

Recall | San Antonio and Bexar residents face a significant digital divide...



20% (390K) of San Antonio/Bexar residents lack access to broadband



...With significant differences across districts, e.g.,

- District 5: 38% lack access
- District 9: 6% lack access



10% (195K) of San Antonio/Bexar residents lack access to devices

...Driven by several factors

Reasons for not using internet (% of respondents)

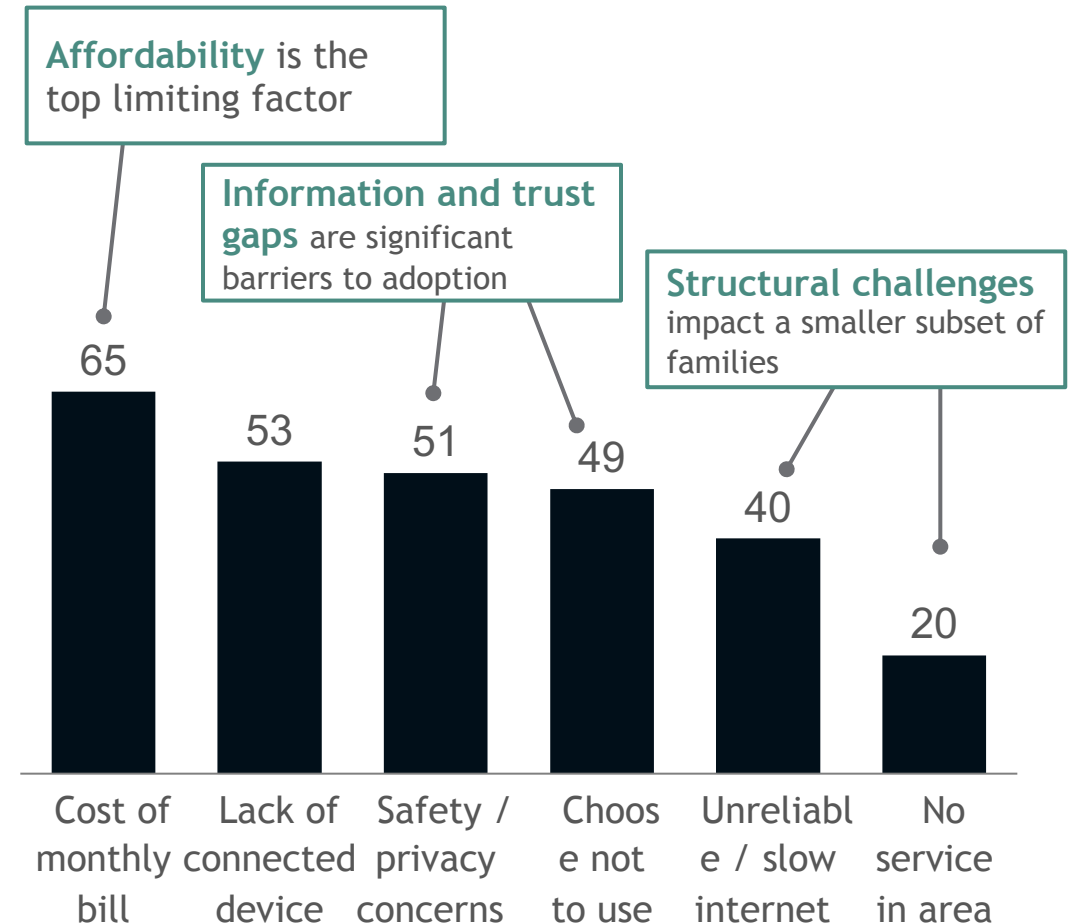

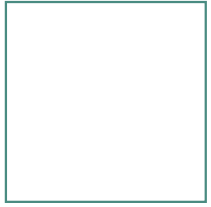

Comparison city research and local efforts

*Preliminary*Key themes from
device support

Many cities get residents to **recycle old devices to be refurbished and distributed**, substantially less investment than purchasing new devices

- *New Orleans government runs city wide device donation program where they destroy data, refurbish devices and donate or sell cheaply to low-income population*

Details on following page



Initiatives often focus on **distributing devices to public school population to support remote learning** and get more donation traction

- *Newark's Board of Education gave out 16,000 new and used devices to public schools in the first six months of the COVID-19 pandemic, leading to 98% of students having access to a laptop or tablet*



If cities **work with large tech / telecom players**, they often will pay for large portion of initiative as part of their social impact campaigns

- *Dallas mayor's office teamed with Siemens, who made \$2M to underserved communities, including 200 laptop donation to Dallas public schools*



Many local governments **partner with charitable organizations** to capitalize on resources, donations and knowledge

- *Phoenix Chamber of commerce teamed up with local United Way organization on refurbished laptop distribution, and youth programing and technology funding*

Key themes from device refurbishment/recycling



Partnering with recycling or refurbishment non-profits will provide access to existing distribution channels and refurbishment technologies

- *Philadelphia works with two non-profits to pick up and refurbish old devices and redistribute them to low-income families*



Establish refurbishment and redistribution programs for devices in public libraries and schools and scale by department or district

- *Maryland partners with EduCycle to recondition and upgrade old computers in university libraries, and distributes additional computers to public schools*



Organize drives and assign dedicated collection days for electronic waste, offering curbside pickup on select occasions

- *Sonoma has dedicated days for electronic waste collection from homes, along with county sites for year-round recycling*



Recycling guides are important resources to educate residents and to streamline refurbishment process

- *Santa Clara provides a detailed guide with instructions on how to reuse, recycle and discard electronic items*

Other city examples: Device support (I/III)

Atlanta	Atlanta Public School district, Comcast	April 2020	<ul style="list-style-type: none"> Fundraising effort with \$300K goal, already exceeded 	<ul style="list-style-type: none"> To address vast discrepancy in tech access made apparent once schools were shut down in pandemic 	<ul style="list-style-type: none"> Previously district has distributed over 15K district owned ipads and laptops to middle school students Now raising money to pay for laptop child can keep and 12 months of internet access Initial goal of \$350K enough to help 1,500 students
New Orleans	Information Technology & Innovation (City Government Org)	August 2020	<ul style="list-style-type: none"> People donate their old devices, government partnerships to wipe and refurbish 	<ul style="list-style-type: none"> New Orleans has one of lowest connectivity rates in US 	<ul style="list-style-type: none"> City is facilitating a device donation program which helps low-income residents acquire computers Also running basic digital skills education and business software application training
Newark	Newark Board of Education	September 2020	<ul style="list-style-type: none"> District purchased 9,000 new low cost devices and received 648 donated devices 	<ul style="list-style-type: none"> When pandemic hit, district said they needed 10,400 low-cost chrome books so students could participate in digital learning 	<ul style="list-style-type: none"> School district has given out 16,000 new and used laptops since between April-Sept 2020, now 98% of children have access to a laptop or tablet These actions came after shortages of devices due to income inequality, funding constraints and shipment delays
New York	NY Public Schools, Verizon	November 2020	<ul style="list-style-type: none"> Verizon is supporting remote learning effort with \$43M commitment 	<ul style="list-style-type: none"> COVID-19 has forced children in NY to learn remotely, which cannot be done without access 	<ul style="list-style-type: none"> 15 NYC Title I middle schools joined Verizon innovative learning in 2020, with free devices and internet access Verizon also donated mobile hotspots to 20k students and COVID grants to education non-profits

Listed initiatives organized by cities

Source: <https://www.ajc.com/news/local-education/350-000-raised-far-give-atlanta-students-computers-more-needed/XYnjCp6kfSKUu3uOwhFl4L/>; <https://nola.gov/iti/digital-equity-overview/resources/>; <https://www.njspotlight.com/2020/09/newark-laptops-students-remote-access-distance-learning-chrome-books-tablets/>; <https://www.globenewswire.com/news-release/2020/11/30/2136861/0/en/Verizon-supports-remote-learning-in-New-York-City-with-43M-commitment-impacting-39-000-students.html>

Other city examples: Device support (II/III)

St. Paul / National	PC's for People	2008-present	<ul style="list-style-type: none"> • 501 C(3) non profit • Monetary donations, and donations of computers and devices 	<ul style="list-style-type: none"> • Charitable organization • US is largest producer of electronic waste in the world 	<ul style="list-style-type: none"> • Have refurbished and distributed over 155K computers around the US • Have connected over 165K families to the internet • Recycled of 8M pounds of technology
National	FCC Emergency Broadband	December 2020	<ul style="list-style-type: none"> • Emergency Broadband Connectivity fund of \$3.2B in treasury 	<ul style="list-style-type: none"> • Help low income households stay connected during pandemic 	<ul style="list-style-type: none"> • Providing discount of up to \$50/month toward broadband services for eligible households • Offer one-time discount of up to \$100 to purchase laptop or other device
Phoenix	United Way, Greater Phoenix Chamber	November 2020	<ul style="list-style-type: none"> • Charitable donations of (3M in cash and \$700K in donated goods) 	<ul style="list-style-type: none"> • 20% of Arizona K-12 students don't have broadband internet • 100K students in Maricopa county don't have computer 	<ul style="list-style-type: none"> • Raised \$3M through grants to non-profits and schools • Supported school districts and funded hot spots • Partnered with PHX Chamber on refurbished laptop distribution
Dallas	Siemens, Dallas Mayor	February 2021	<ul style="list-style-type: none"> • \$2M pledge from Siemens USA 	<ul style="list-style-type: none"> • Siemens wants to give back to underserved communities in pandemic, began with Dallas ISP 	<ul style="list-style-type: none"> • Donated 200 laptops to select Dallas low-income neighborhood schools • In addition, \$2M pledge to Comm Development Financial Institution Funds to support social and economic equity • Additional Donations to HBCU's

Listed initiatives organized by private and charitable organizations

Other city examples: Device support (III/III)

Saint Paul/ Denver/ Baltimore	City of St Paul, PCsforPeople	1998	PCsforPeople	<ul style="list-style-type: none"> • Provide affordable computers to those in need 	<ul style="list-style-type: none"> • Offer business secure recycling solutions • Donates refurbished items to low-income individuals and nonprofits
Maryland	Towson University, EduCycle	2020	EduCycle Computer Reconditioning Program	<ul style="list-style-type: none"> • Reconditions old computers to provide students with upgrades 	<ul style="list-style-type: none"> • EduCycle expands the lifespan of computers by upgrading the system without having to invest in a new machine • Used computers are sourced through departments in the university and donations • Additional computers are donated to public schools
Arizona	Arizona Schools	2001	Arizona Students Recycling Used Technology	<ul style="list-style-type: none"> • To support Arizona's technical education and contribute to a sustainable future 	<ul style="list-style-type: none"> • AZStrut takes donated used technology, refurbishes and redistributes to student families, schools and library lending programs
Santa Cruz	City of Santa Cruz	2018	Resource Recovery Facility	<ul style="list-style-type: none"> • To create a resource to encourage residents to recycle sustainably 	<ul style="list-style-type: none"> • Residents can bring used devices to public libraries for recycling or refurbishment • City offers once a year pick up of old items and bulky items by appointment • Guide provides alternative ways to recycle and reuse
Philadelphia	City of Philadelphia, At&T, Retrievr	2019	PHLDonateTech	<ul style="list-style-type: none"> • Provide access to devices for families in need 	<ul style="list-style-type: none"> • Retrievr will pick up donations of 25 items or more and refurbish to donate to non-profits (smaller donations will be forwarded to NERDit foundation)
Sonoma	Sonoma County Waste Management Agency	2019	Zero Waste Sonoma	<ul style="list-style-type: none"> • To help residents recycle in an environmentally responsible way 	<ul style="list-style-type: none"> • Residents or businesses can drop off electronic waste at designated sites • Dedicated days for e-waste collection • Offers recycling guides, resources and support

Source: <https://zerowastesonoma.gov/about>; <https://cityofsantacruz.recyclist.co/guide/?embeddedguide=true>; <https://azstrut.org/>; <https://zerowastesonoma.gov/about>; <https://cityofsantacruz.recyclist.co/guide/?embeddedguide=true> <https://www.towson.edu/technology/facultystaff/hardwaresoftware/buying/reconditioning.html>; <https://www.pcsforpeople.org/about-us/>; <http://www.mayorsfundphila.org/initiatives/phldonatetech/>

Current efforts underway to supply free/low-cost devices

Operation Connectivity

- Statewide initiative since March to offer devices (e.g., laptops, tablets) and connectivity to students for free; from May-Dec. 2020 acquired 4.5M devices at cost of \$200M

Bibliotech/SAHA Partnership

- As part of extension of digital library services to public housing, Bibliotech offers technology courses that, upon completion, award a free laptop or desktop PC to graduates

School 1:1 programs

- Extension of existing school district programs (e.g., in SAISD) to ensure each student has one laptop or Chromebook; includes costs for maintenance and repair

San Antonio Public Library Foundation

- Device donation program for seniors, raising \$150K to distribute over 100 tablets and laptops

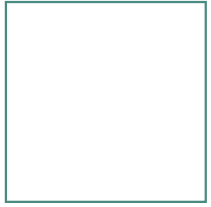

Recommendation

5

Device-related solutions

Detailed recommendations

Preliminary

- 5A **Develop comprehensive understanding of need and technical requirements**
 - Conduct outreach (e.g., surveys, door-to-door) to determine household need and how it breaks down by sub-group (e.g., seniors, students, veterans)
 - Define technical specifications required for hardware, software and security protections that can enable cross-sector applications (e.g., education, health)

- 5B **Establish mechanisms to sustainably supply devices to residents**
 - Identify available funding streams that can support device procurement
 - Collaborate with community groups and local businesses on device donation drives to recycle unneeded devices
 - Establish financial incentives (e.g., subsidies, rebates) to encourage the private sector to supply needed devices through innovative solutions
 - Coordinate local businesses participation in device recycling through key community economic anchor institutions (e.g., SAEDF)
 - Encourage ISPs to offer free devices (e.g., service contracts covering device costs & replacements/repairs; device bundling that includes free Wi-Fi)

- 5C **Determine appropriate distribution channels to support device distribution**
 - Assess methods to best enable organizations already engaged in free/low-cost device procurement (e.g., school districts, Goodwill, SAHA, BiblioTech)
 - Explore opportunities to connect device support with other relevant aspects of digital equity strategy (e.g., adoption support)



Multiple potential strategies to make connected devices more accessible



Service contracts

Partner with wireless providers to offer service contracts that cover the cost of new devices, replacements, and repairs



Bundling device & connectivity

Wireless providers could offer bundling services that would offer low-income subscribers connected devices with embedded Wi-Fi/other connectivity options at no additional cost



Donation of connectivity devices

Business and community partners can be encouraged to help provide devices for residents to connect to the internet. Work with wireless carriers to create or expand personal Wi-Fi hotspot account programs with schools and other nonprofits

Table of contents

3	Fact-base
4	Summary
6	Interviews and Community Engagement
19	Inventory Survey
28	K-12 Questionnaire
33	Size and Nature of the Digital Divide
47	ISP Economics & Engagement
56	Initiative Details
57	Infrastructure
93	Affordable Housing Access
104	Education Sponsored
127	Low-income Internet
149	Device Support
162	Adoption Support
191	Data & Analytics
214	Operating Model
244	Population Segments
250	Implementation Roadmap
273	Funding Databases
290	Asset Maps
291	Access Maps
294	Coverage Maps
300	Community Level Maps

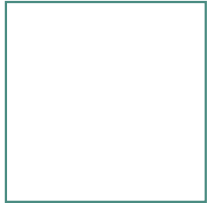

Nature of the problem

Summary | Overview of the (non-financial) adoption barriers faced by SA / Bexar County



It is possible that all the 130K+ Bexar County households with adequate broadband face adoption barriers, with **67K to 100K households** (50-75%) explicitly saying so



~50% of residents have cited **safety / privacy concerns** and "**choose not to use**" as reasons for not using the internet



Preexisting **socioeconomic challenges** and **systematic social exclusion** continue to leave marginalized communities out of digital opportunities and resources



Bexar County is a racially diverse area, with a **largely Hispanic population** that has historically faced adoption barriers (e.g., language needs, distrust in gov, hesitancy sharing personal info)



Adoption efforts may need to **build on previously unlocked affordability solutions** (e.g., low-cost internet, federal program)

San Antonio and Bexar households face a significant digital divide...



20%+ (130K+) of San Antonio / Bexar households lack access to broadband



...With significant differences across districts, e.g.,

District 5: 38% lack access

District 9: 6% lack access



10%+ (65K+) of San Antonio/Bexar households lack access to devices

...Driven by several factors

Reasons for not using internet (% of respondents)

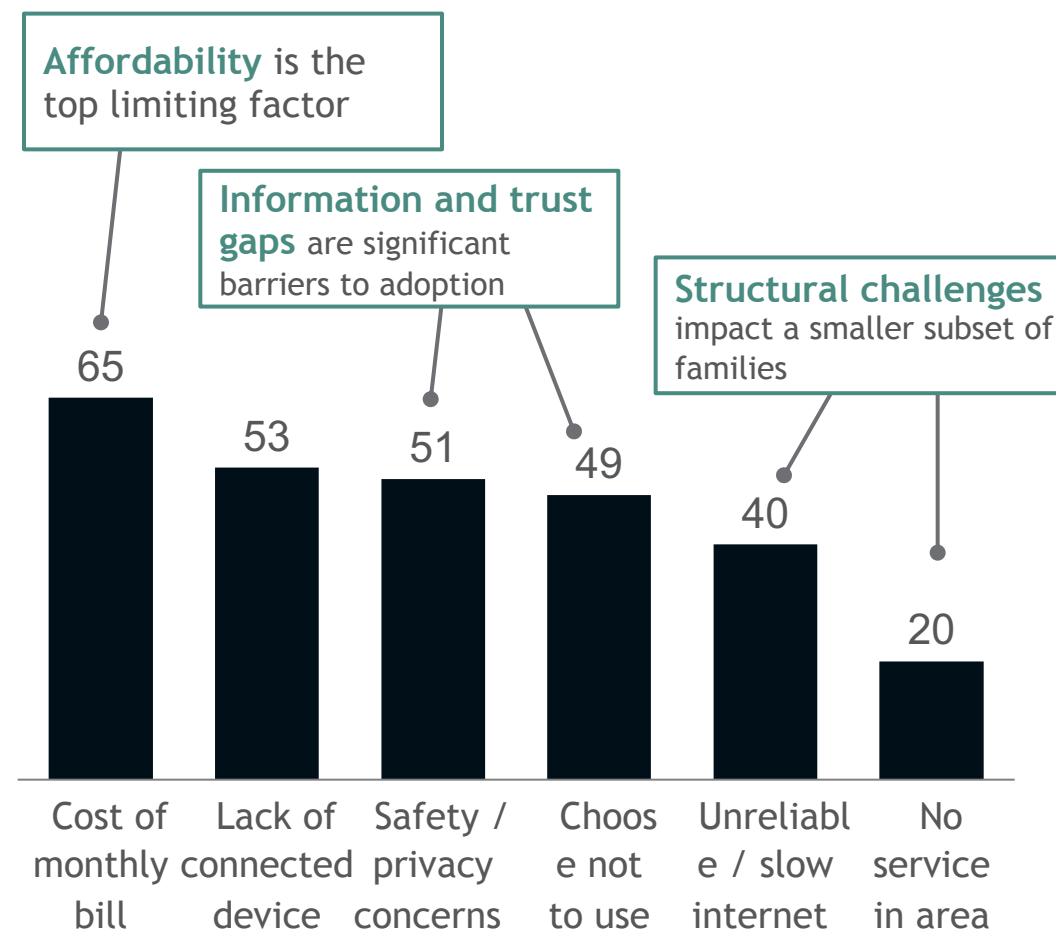

Current assessment of the size and nature of the digital divide in SA / Bexar by number of households

Size of the divide



Households (20%+ of all hhds.) without adequate broadband access



Households (10%+ of all hhds.) without connected devices

Barriers to adoption



Availability

50K

Households (40% of disconnected hhds.) lack access to reliable, adequate (100 mbps) coverage



Affordability

90K

Households (70% of disconnected hhds.) report not having access because they cannot afford their monthly bill



Adoption

Up to 130K

Households (up to 100% of disconnected hhds.) face adoption barriers including lack of comfort with digital tools, language barriers, etc.

Households may face more than one barrier

Affordability and adoption are the greatest barriers to access; extent of availability challenges varies by source and service quality

Category	Sources	# and % of households	Considerations
Availability: Unserved	Broadband Now	5K <i>(0.8% of HHDs)</i>	<ul style="list-style-type: none"> • Unserved by 25 mbps coverage
	SASpeakUp ¹	27K <i>(4% of HHDs)</i>	<ul style="list-style-type: none"> • Reported not having internet because there was no service in their area
Availability: Underserved	Broadband Now	9K <i>(1.4% of HHDs)</i>	<ul style="list-style-type: none"> • Unserved by 100+ mbps coverage
	SASpeakUp	53K <i>(8% of HHDs)</i>	<ul style="list-style-type: none"> • Reported not having internet because service was slow or unreliable
	Broadband Now	201K <i>(30.1% of HHDs)</i>	<ul style="list-style-type: none"> • Unserved by 1 gig coverage
Affordability	SASpeakUp	87K <i>(13% of HHDs)</i>	<ul style="list-style-type: none"> • Reported not having internet because could not afford the monthly bill
	ACS data	211K <i>(33% of HHDs)</i>	<ul style="list-style-type: none"> • % with income less than \$50K, proxy income for hhd. of 4 eligible for the National School Lunch Program
Adoption	SA SpeakUp	67-100K <i>(10-15% of HHDs)</i>	<ul style="list-style-type: none"> • Reported not having internet service because of data & privacy concerns or chose not to²

2. Survey asked if residents had access to the internet. 20% reported a lack of access. The survey then asked those without access "why". 1. 51% of respondents without access said they had security or privacy concerns; 49% of respondents without access said it was because they chose not to. Assumed 0-50% overlap

Adoption barriers significantly tied to preexisting socioeconomic challenges and patterns of exclusion

“[AT&T] is basically to the curb in every residence in San Antonio. But there’s a tremendous gap in digital literacy and understanding (how to use) broadband services. We are beginning to look at public education as a way of bridging the Digital Divide because **it’s not necessarily infrastructure anymore**. It’s costs and competition, which we have a great way of affecting, and it’s also digital literacy, which we have a desperate need to affect.”

*-Ron Nirenberg, Councilmember
for San Antonio's 8th District*

“[Lack of infrastructure] is not the problem at hand because high and low connectivity areas are less than 5 miles apart. Instead, **the driver of this digital divide is the systematic social exclusion and structural oppression of marginalized communities** left out in the past from opportunities and resources.”

*-Digital Inclusion Survey
& Assessment (2019)*

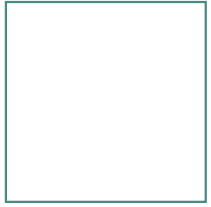

Comparison city research and local efforts

Successful local and national awareness campaigns require a thorough, decentralized approach with clear messaging

Key elements of strong awareness campaigns



Multiple channels should be leveraged including online (e.g., email, websites, social media) and offline (e.g., flyers, radio, phone calls)



Messages must reach families in their **normal day-to-day** (e.g., on commute, at store) and come from **trustworthy sources** (e.g., teachers, community leaders, celebrities)



Short, catchy phrases with **strong, resonating messaging** enable an exponential chain of information sharing via word-of-mouth



The information must be **clear and actionable** in order to unlock real change



Example awareness campaigns

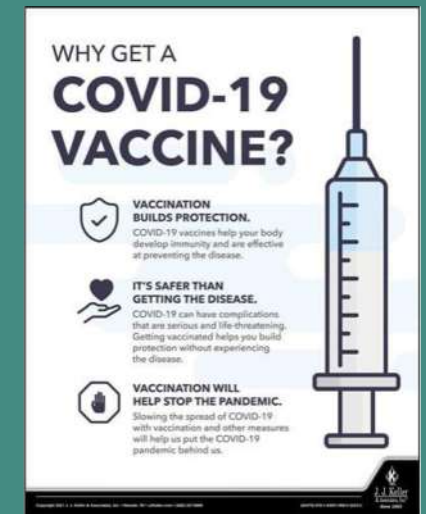

The Digital Navigator model, supported by NDIA, helps communities achieve digital inclusion

Digital Navigators are individuals who address the whole digital inclusion process – home connectivity, devices, and digital skills – with community members through repeated interactions

How Digital Navigator Program works



Identify and map digital inequities



Identify digital inclusion assets



Identify digital inclusion programming gaps



Build a broad-based digital equity coalition

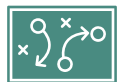

Create a digital equity plan



Implement the digital equity plan

In almost any community, a dedicated Digital Navigator is a key component of any successful digital equity plan. Navigators can be volunteers or cross-trained staff who already work in any number of community organizations including:



Social service agencies



Libraries



Health services

Case study | Philadelphia

Context: In 2021, The City of Philadelphia announced two new organizations with Digital Navigator services and emphasized how the program can provide digital support to residents during the pandemic and beyond. Digital Navigators will assist residents in the following ways:

- Find and apply for affordable internet connectivity
- Obtain low-cost or free computers
- Offer support with simple online tasks
- Link to online digital literacy training

Key themes from digital skill leveling / badging programs

Preliminary



Offering digital skills programs in different languages, locations, and media can **enable residents to gain access to resources** and upskill at their convenience

- *Austin hosts multilingual classes, offered both at the public library and online along with offering courses to earn technical support certification*



Digital literacy certification programs are offered at two levels: to **enable basic digital access** to those in need, and to **equip students or job seekers** with coding or robotics skills

- *Baltimore's programs allow residents to earn basic badges for computer skills as well as advanced credentials from Microsoft Office or IBM*



Teacher and tutors should be **trained through dedicated programs and resources** on how to provide digital literacy training to residents

- *Philadelphia provides grants to organizations to train Digital Navigators and provide them with skills to train seniors and residents in need*



Local government can support existing digital skill leveling programs by **providing funding via grants** and **facilitating as a hub** for various digital literacy initiatives

- *Seattle gave out grants to several digital literacy initiatives, while Chicago collects and hosts several digital trainings on their platform*

Digital Skill Leveling / Badging Programs - (I/II)

Baltimore	City of Baltimore, Microsoft	2021	Digital Alliance	<ul style="list-style-type: none"> Improving digital skills is considered essential, and especially crucial to support residents adapt to new normal 	<ul style="list-style-type: none"> Online programs for residents to earn credentials in coding and robotics through Microsoft learning partnership or IBM skills Digicamp to introduce students to IT careers and provide tech workshops Microsoft prepares city employees on how to give digital literacy trainings
Austin	Office of Telecommunications and Regulatory Affairs	2016	Austin Free-Net	<ul style="list-style-type: none"> Part of the digital inclusion strategic plan, designed to overcome barriers to resident participation in digital society 	<ul style="list-style-type: none"> Bilingual classes for seniors, homeless and general population, offered online and at recreation and resource centers Literacy program focuses on basic digital skills, including using a computer/tablet and going online Accelerate IT certificate to train individuals for free in providing tech support (funded by Texas Workforce Commission grant)
San Jose	City of San Jose Parks, Recreation and Neighborhood Services, Mayor's Office of technology and Innovation	2020	SJ Access	<ul style="list-style-type: none"> Close digital divide through expanding digital adoption and literacy skills in communities 	<ul style="list-style-type: none"> Offer basic levels of digital classes for older adults focused on computer usage and finding, organizing and sharing information online Self-taught online courses on using email, navigating operating system, word processor, using online storage and websites Offers multi-lingual programs

Source: <https://www.sanjoseca.gov/your-government/departments-offices/parks-recreation-neighborhood-services/digital-literacy> ; <https://technical.ly/baltimore/2021/03/29/microsoft-digital-literacy-courses/>; <https://www.austintexas.gov/departments/community-technology>; <https://austinfreenet.net/classes/dlprogram/>

Digital Skill Leveling / Badging Programs - (II/II)

Chicago	City of Chicago, Microsoft, Google	2020	Chicago Connected	<ul style="list-style-type: none"> To support families that lack access to digital resources and are in need 	<ul style="list-style-type: none"> Resources for public school students, and higher education Basic and advanced training courses available in public libraries and online (through Google Workspace and Microsoft Office)
Philadelphia	City of Philadelphia, universities, and other non-profits	2020	Digital Literacy Alliance / Digital Navigator	<ul style="list-style-type: none"> Enabling digital access to residents and communities in response to the pandemic 	<ul style="list-style-type: none"> Organizations in the community will create Digital Navigator positions; Navigator will provide remote digital literacy training and help residents apply for internet access
Seattle	Seattle IT, various digital literacy programs	2020	Technology Matching Fund	<ul style="list-style-type: none"> Funding organizations that are focused on women and young adults in low-income neighborhoods 	<ul style="list-style-type: none"> Literacy Source provides basic computer and digital literacy skills Organizations focused on educating Eritrean, Somali and Filipino neighborhoods Education Mobile Youth Workshops to provide digital cinematic skills Young Women Empowered provides coding and digital skills certificates, host panel speakers and workshops

Source: <https://www.chicago.gov/city/en/sites/chicago-connected/home.html>; <https://www.phila.gov/2020-05-28-city-announces-recipients-of-the-digital-literacy-alliances-fast-track-grant-cycle-to-promote-digital-access-during-covid-19/>; <https://statescoop.com/seattle-distributes-345000-to-digital-literacy-organizations/>; <https://youngwomenempowered.org/our-programs/tech/>

Adoption efforts underway in SA / Bexar County offer models to scale

Illustrative, Non-Exhaustive

Texas A&M help desk / digital scholars program

- The university is piloting a help desk to develop digital literacy among students; once students graduate for the program, they can work in it for \$10/hour and help others learn digital skills

SAHA ConnectHomeSA

- Through ConnectHomeSA / BiblioTech, digital literacy course are offered covering computer / internet basics, productivity software (e.g., Word, PowerPoint), cybersecurity / privacy, etc.

OATS catalyst partner program

- Senior Planet developed a train-the-trainer model in which they recruit volunteers from orgs deeply connected to seniors and train them to teach seniors digital skills

SAISD digital courses / tutorials

- SAISD offers students digital citizenship courses, basic digital tutorial sessions for parents and students, and a technical help desk to answer question student / families have on digital

Comprehensive list of local adoption efforts to be built out via Inventory Survey

OATS / Senior Planet offers the wrap-around digital skill building to launch a Digital Navigator program

A San Antonio based program that has increased digital engagement in the elderly community by developing an effective "train the trainer" model



Senior Planet Virtual courses (non-exhaustive)

- Personal finance
- Online RX / health resources
- Intro. to social media
- How to spot fake news
- Contacting lawmakers
- Cybersecurity / privacy



Why it works

OATS is successfully expanding digital inclusion for seniors with its key values:

- Ensure seniors **feel positively engaged** in their learning and not made to feel old / ashamed
- Select trainers who **have the patience** to teach seniors digital and don't get frustrated easily
- Design **services / messaging around specific needs** of the demographic it serves



Measuring impact



Net promoter score seniors give to OATS courses



SA OATS seniors who saw measurable improvement in their social connectedness

SAPL, Bibliotech, SAHA, among others offering similar digital literacy skills training

Need for digital across use cases builds motivation for adoption and creates opportunities to practice usage

Example



Learn something new and have fun with FREE online events!

Senior Planet from AARP in San Antonio helps people 60 and older learn to use technology to reach their goals, find community, and thrive in the digital world.

- Learn to use your phone or computer
 - Get moving with a group fitness class
 - Save money by paying your bills online
- ...and so much more!

Have a technology question? Call our hotline:

📞 210-504-4862

Or visit us online:

www.seniorplanet.org/sanantonio

SENIOR PLANET
SAN ANTONIO FROM AARP

Minimize other barriers to adoption (e.g., cost) and create opportunities to practice usage

Highlight technology as beneficial to holistic well-being

Motivate action by highlighting use cases specific to the populations of interest

Make it clear and easy to access supporting resources across channels

Coordinating with the City and County to drive EBB adoption campaign

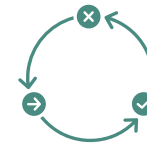

Build Awareness

- Arm **community organizations** (e.g., Texas A&M, SAHA), **school districts**, and **libraries** with digestible promotional materials (illustrative example on next page)
- **Share EBB information** through City / County channels (e.g., website, newsletter, social media)

Stand up support network

- Set up **City / County call centers** to support EBB enrollment process
- Partner with **community orgs**, **schools**, **libraries** to enroll families and direct questions to the hotline
- **Upload helpful links** to a City / County resource center, sharing the latest application / support information and FAQs

Create feedback channels

- Create channels (e.g., EOD Zoom call, Google form) for call centers, residents, ISPs to **share questions, feedback, and pain points**
- Incorporate feedback into **refined materials / processes** and expand the set of support community orgs to **build a broader adoption ecosystem**

A successful launch of the EBB program, coordinated by SA / Bexar, can **build trust in the community** and increase momentum behind a **supportive, digital ecosystem** of community orgs, ISDs, and philanthropies that will **organically engage disconnected households** (e.g., reveals adoption needs and key barriers faced)

Local Efforts: Adoption support (I/IV)

Organizations aggregating informational / resources and building awareness

- Texas Veterans Network
- Good Samaritan Community Services
- UT Health San Antonio
- MICRO:SA
- North San Antonio Chamber of Commerce
- American Indians in Texas at the Spanish Colonial Missions
- Intercultural Development Research Association
- Southwind Fields
- Libraries Without Borders US
- San Antonio Clubhouse

Examples of how orgs have supported this initiative

- “ We provide resources and **serve as an extended resource that executes functional responsibilities** to aid small businesses in performing tasks necessary to be more sustainable and/or productive - MICRO:SA
- “ We equip students **with knowledge of how to access resources**, connectivity and appropriately navigate online spaces- Intercultural Development Research Association



Local Efforts: Adoption support (II/IV)

Organizations providing technical support or one-on-one assistance

- Texas Veterans Network
- Good Samaritan Community Services
- UTSA Small Business Development Center
- UT Health San Antonio
- The Children's Bereavement Center Of South Texas
- Intercultural Development Research Association
- Adult Years Program
- SAISD/AYVP/ Project SEARCH
- SAISD
- San Antonio Housing Authority
- Libraries Without Borders US
- Family Service Association of San Antonio, Inc.
- Madonna Center, Inc.
- LISC San Antonio
- San Antonio Clubhouse
- Habitat for Humanity of SA
- Alamo Colleges District

Examples of how orgs have supported this initiative

- “ We provide resources and **serve as an extended resource that executes functional responsibilities** to aid small businesses in performing tasks necessary to be more sustainable and/or productive - MICRO:SA
- “ Our program allows **students with disability to participate without loss of information**. The speech to text allows the student to search, complete and participate - Project SEARCH
- “ Students use **personal cell phones on worksites to find products and for Via transit bus stop times** - Adult Years Program
- “ Our staff will provide **technical assistance to navigate the digital options** we use in delivering our services - Habitat for Humanity of SA

Local Efforts: Adoption support (III/IV)

Organizations providing basic digital skills training

- Rise Recovery
- Good Samaritan Community Services
- Youth Code Jam
- SAMSAT -- San Antonio Museum of Science and Technology
- UT Health San Antonio
- Webhead
- Intercultural Development Research Association
- YMCA of Greater San Antonio
- Adult Years Program
- MY Charity
- SAISD/AYVP/ Project SEARCH
- SAISD
- Bexar County Commissioners Court
- San Antonio Housing Authority
- Southwind Fields
- Libraries Without Borders US
- Family Service Association of San Antonio, Inc.
- Girls Inc. of San Antonio
- San Antonio Clubhouse
- Alamo Colleges District
- National Hispanic Institute at San Antonio

Examples of how orgs have supported this initiative

- “ We are partners with UTHSC to **provide tele-peer support services** across three regions in Texas - Rise Recovery
- “ Our main digital literacy focus is **basic digital skills training through our sponsored program, Microsoft-SAMSAT Digital Academy**, including training both older high school students and adults - SAMSAT
- “ We **teach computer basics and offer hands-on training** on usage - San Antonio Clubhouse
- “ We utilize a multitude of platforms for engagement. Students and families are not only exposed to them **but are trained on them and by the time they finish their leadership experience are able to navigate and master these platforms** - National Hispanic Institute at San Antonio

Local Efforts: Adoption support (IV/IV)

Organizations providing advanced digital skills training

- Good Samaritan Community Services
- Youth Code Jam
- SAMSAT -- San Antonio Museum of Science and Technology
- Intercultural Development Research Association
- Adult Years Program
- Adult Youth Vocational Program
- SAISD/AYVP/ Project SEARCH
- SAISD
- San Antonio Housing Authority
- Madonna Center, Inc.
- Alamo Colleges District

Examples of how orgs have supported this initiative

- “ We teach **coding, computer science, digital literacy, cybersecurity, digital Safety, STEM education,** parent/guardian resources and support - Youth Code Jam
- “ Through our Broadway Bank-sponsored Computer Literacy for the Workplace program, **we deliver selected computer literacy training classes** - SAMSAT



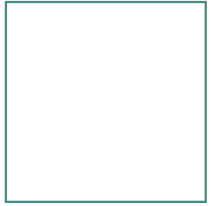

Recommendation

6

Adoption solutions

Detailed recommendations

Preliminary

- 6A Conduct multi-channel campaigns to spread awareness across population segments**
 - Establish a network of trusted grassroots orgs to reach households and publicize programs catered to specific populations
 - Drive awareness campaigns through multiple channels and languages
 - Distribute flyers in commonly-visited locations (e.g., grocery, doctor's office)

- 6B Create help desks and other forums for personalized technical support to help households enroll in programs and connect to the internet**
 - Stand up hotlines (e.g., City or County call center, Texas A&M help desk) and train employees to guide families through enrollment
 - Engage minority-focused CBOs to ensure culturally relevant assistance
 - Partner with organizations already in touch with specific populations (e.g., veterans, seniors, public housing) to get households enrolled

- 6C Engage in widespread digital skills leveling through 1:1 digital training programs and the expansion of digital literacy and learning across sectors**
 - Stand up Digital Navigator programs that provides 1:1 digital training to newly connected individuals in the community, building on the successful OATS model
 - Partner with education entities (e.g., K-12, higher ed, job training, libraries) to advocate for standardized digital competencies (e.g., defined digital skill credentials) in school curriculums and workforce programs

- 6D Coordinate adoption initiatives and strategy across stakeholders**
 - Engage key stakeholders to align on adoption plans and aggregate existing efforts for each major initiative (e.g., EBB, E-Rate, 5G rollout)
 - Create feedback channels and a data collection strategy (e.g., surveys) to continually improve the adoption support network

Many pathways exist to help families achieve digital inclusion

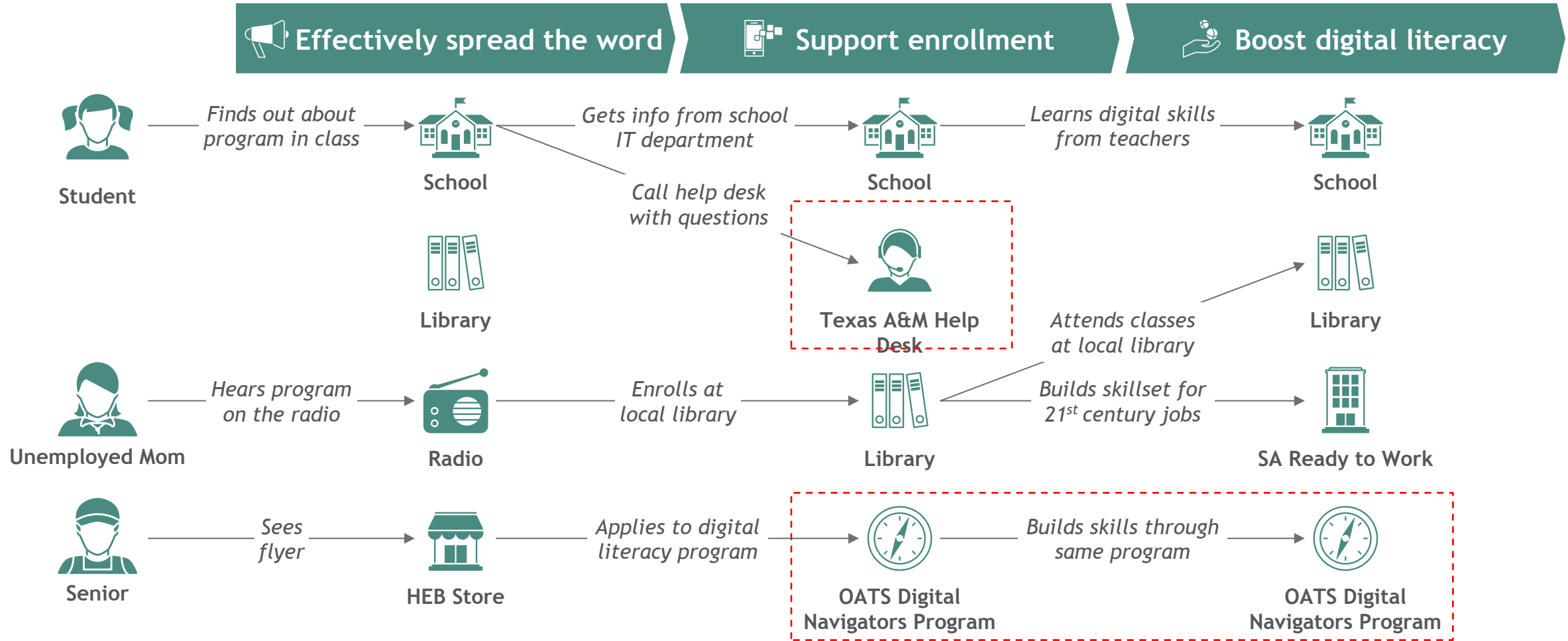

 Deep dive topic

Effective adoption ecosystems require a coordinated but decentralized approach that targets as many disconnected subgroups as possible

Raise awareness by sharing engaging, digestible messages through trusted channels

Illustrative, Non-exhaustive

Core principles to employ...

- Select organizations that are "**network weavers**" and trusted by disconnected families
- Reach families in their **normal day-to-day** (e.g., on commute)
- Help families **understand the benefit** of internet and **discuss any existing signup concerns**
- Share information in **languages / terms they understand** via online and offline channels
- Clearly **identify next steps**



...when raising awareness for digital programs across stakeholders

Schools / Libraries (via staff, newsletters)

- Bibliotech
- SA Public Libraries
- Schools (ISDs, charter, private)

Gov Agencies (via website, emails)

- Bexar County
- SA (Innovation, EDD, Equity)
- Mayor's Office

Community Organizations (via word-of-mouth, PR team)

- AARP
- Alamo Workforce
- City Education Partners
- COPS / Metro Alliance
- Faith-based Orgs
- LISC
- Methodist Healthcare
- OATS / Senior Planet
- SA Ready to Work
- SA2020
- SAHA
- Southside First
- Texas A&M San Antonio
- Up Partnership
- USAA

Frequently Visited Places (via flyers, employees)



- Food Banks
- Goodwill Industries
- HEB
- Parks & Rec
- Senior Centers
- Tax Offices
- VIA Metro Transit

Media Outlets (via ads, articles, posts)

- Magazines
- Newspapers
- Radio stations
- Social media
- TV advertisements

*Coordinating hub to meet regularly (e.g., biweekly) with coalition of community organizations **to solicit input, ensure buy-in** for upcoming campaigns, and **add to the SA network** of grassroots organizations*

Community organizations should tailor their adoption strategy based on the population they are interacting with

	Population	Available Solution(s)	Adoption Strategy
	Small Business	City / County grants, municipal networks	<ul style="list-style-type: none"> • Increase awareness for local programs that offer funding to develop small businesses through existing government channels • Create a municipal network that small businesses can connect to at affordable prices
	Households	Low-income subsidies	<ul style="list-style-type: none"> • Leverage community organizations that reach all corners of the community to spread word (e.g., phone calls, door-to-door) of affordable options (e.g., Lifeline)
	Veterans	Low-income subsidies	<ul style="list-style-type: none"> • Work with veteran organizations (e.g., Endeavors, AACOG, NVOP) to connect veterans with affordable broadband options • Socialize workforce programs, highlighting that digital skills unlock job opportunities
	Seniors	Low-income subsidies	<ul style="list-style-type: none"> • Connect seniors to broadband through existing communities (e.g., nursing homes) and programs that work closely with them already (e.g., AARP, OATS)
	Students	School-sponsored solutions (e.g., E-Rate, 1:1 device programs)	<ul style="list-style-type: none"> • Work with school districts and libraries to socialize available programs and support digital training • Leverage education funds (e.g., E-Rate, grants) to help close the homework gap
	Public Housing	Affordable housing initiatives	<ul style="list-style-type: none"> • Support ongoing initiatives (e.g., SAHA) to provide internet and digital literacy to public housing by offering available resources and funding

Two centralized call centers can be stood up to build on the enrollment efforts of school, libraries, and CBOs



City / County Call Center

- **Trained call center** staffed by the city and county can also support digital initiatives
- Staff would **pre-screen and enroll** callers in select digital programs
- Additional resources including **FAQs and ISP contact information** would be provided
- Potential to **use one phone number** between the two call centers to support higher call volumes



Texas A&M Help Desk

- Texas A&M is standing up a help desk to serve as a **one-stop-shop** for all digital questions
- Program **hires, coaches, and certifies** high school / college students to manage the front-line help desk
- Requests are **processed and tracked through ticketing systems** shared between A&M and ISDs
- Their digital scholars program increases the number of **trained community ambassadors**, creating a multiplicative effect for digital inclusion

Community organizations can route households to call centers and, once enrolled, call centers can point users to community support programs (e.g., Digital Navigator programs, library resources) to build their digital toolkit

Digital Navigator programs are a proven model for onboarding new digital users



Who is a digital navigator?

Hired volunteers or staff from:

- Libraries
- Social service agencies
- CBOs
- Philanthropies

Leverages **support from community members** with local knowledge who have familiarity interacting with people



How does the program work?

- The program **trains staff** to teach digital equity, providing each new user an assigned navigator
- Navigators assess needs and point users to helpful resources, including **digital tools and online services** (e.g., rent, food support, healthcare, education)



Why does it work?

- Continual, one-on-one contact with trusted community members ensures **each individual's needs will be met**
- The framework centralizes support to **concurrently identifies and solve gaps** in digital understanding

- **Successful Digital Navigator programs** have been stood up in Philadelphia, Minnesota, Salt Lake City, Cleveland, Seattle, Nashville, Austin, Portland, Denver, Providence, and more
- **Existing SA orgs** have capabilities to support these programs (e.g., OATS, SAPL, Bibliotech)

Three key actions for the coordinating hub to enable an effective adoption ecosystem



Coordinate adoption campaigns

- Partner with community orgs to maximize adoption and troubleshoot challenges for **government programs and digital equity initiatives**
- **Support the campaign effort** where needed (e.g., collect program info, create multilingual collateral, prepare call centers, identify funding)
- **Align on a communication strategy** to share upcoming programs with key distribution points and the network of grassroots organizations



Aggregate resources and best practices

- Post resources (e.g., helpful links, directory of digital inclusion entities) on the **community portal** of the City / County website
- Provide best practice digital inclusion efforts from **municipality exemplars**
- Identify the **KPIs that corporations are looking for** in order to inform how business can be brought to the city



Create feedback channels

- Create forums for community organizations and call centers to **share questions, feedback, and pain points** across the customer journey
- **Incorporate findings into refined processes** and expand the network of support organizations to build a broader adoption ecosystem
- Collect / analyze population data over time to **inform future digital initiatives**

Table of contents

3	Fact-base
4	Summary
6	Interviews and Community Engagement
19	Inventory Survey
28	K-12 Questionnaire
33	Size and Nature of the Digital Divide
47	ISP Economics & Engagement
56	Initiative Details
57	Infrastructure
93	Affordable Housing Access
104	Education Sponsored
127	Low-income Internet
149	Device Support
162	Adoption Support
191	Data & Analytics
214	Operating Model
244	Population Segments
250	Implementation Roadmap
273	Funding Databases
290	Asset Maps
291	Access Maps
294	Coverage Maps
300	Community Level Maps

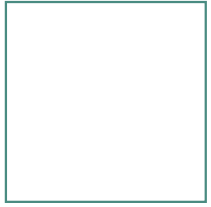

Nature of the problem

Identified areas for continued effort around data and analytics



Performance metrics to measure success and communicate the impact of digital access



Public facing online portals/dashboards to direct residents to community resources and provide status updates on progress

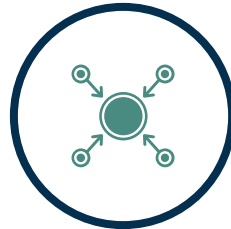

Centralized, continuous data collection with clear accountabilities and ownership



Robust analytics on collected data to optimize solution initiatives and refine data collection/aggregation processes



Improved stakeholder coordination and information sharing

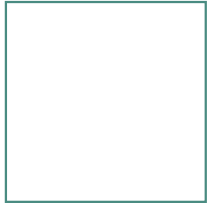

Comparison city research and local efforts

Key themes from data and analytics



Local governments **conduct surveys and collect data from residents and families** to quantify digital connectivity

- **New York** Digital Equity Survey asked teachers about student devices and digital access and collected data by grade level and by location of use



Tracking **broadband infrastructure** is essential to monitor, maintain or expand digital network assets as needed

- **Los Angeles** tracks hard assets like building infrastructure using small cell nodes to identify and monitor



Information on **community resources** should be updated and disseminated regularly to residents

- **Portland** Digital Inclusion Network page allows users to share on-the-ground information and provides a community directory with links to resources



Presenting a **comprehensive view of digital divide** will help identify any gaps as well as spread awareness in residents

- **North Carolina** uses a map to display various data points, including hard assets, soft assets and unmet digital needs in the community

Case study | Portland, OR - Digital Inclusion Network (DIN)

In response to COVID-19, Portland's Digital Inclusion Network has been collaboratively working to overcome digital access barriers faced by underserved populations. As part of their efforts, tracking and disseminating data has been central.

Action tracker/resource portal

- Provides a virtual space for information sharing and communications among community orgs involved in expanding access
- Captures on the ground experiences and resource needs to crowd-source solutions
- Shares information about connectivity, devices, technical support services, and funding support with community

Services organized by household need with organizations ready to support each area

Community directory

Provides publicly available information on the following:

- Areas to access public Wi-Fi
- List of low-cost internet providers/device programs
- Technical support/ digital literacy courses

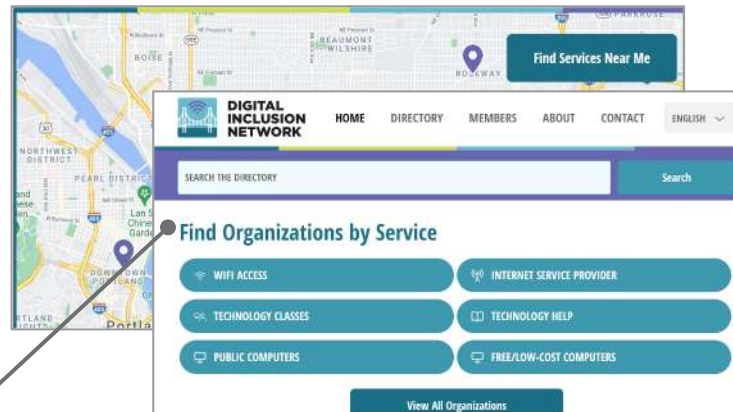

Community need dashboard

Integrates GIS maps of digital access and local efforts in order to:

- Measure and track impact
- Identify gaps in service and unmet need
- Track racial and socio-economic equity

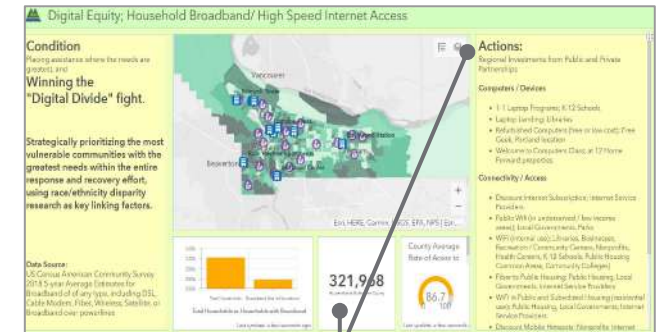

Provides status update of digital divide performance metrics with gaps prioritized for future action

Case study | North Carolina offers model for San Antonio/Bexar County mapping efforts

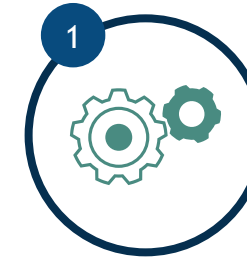
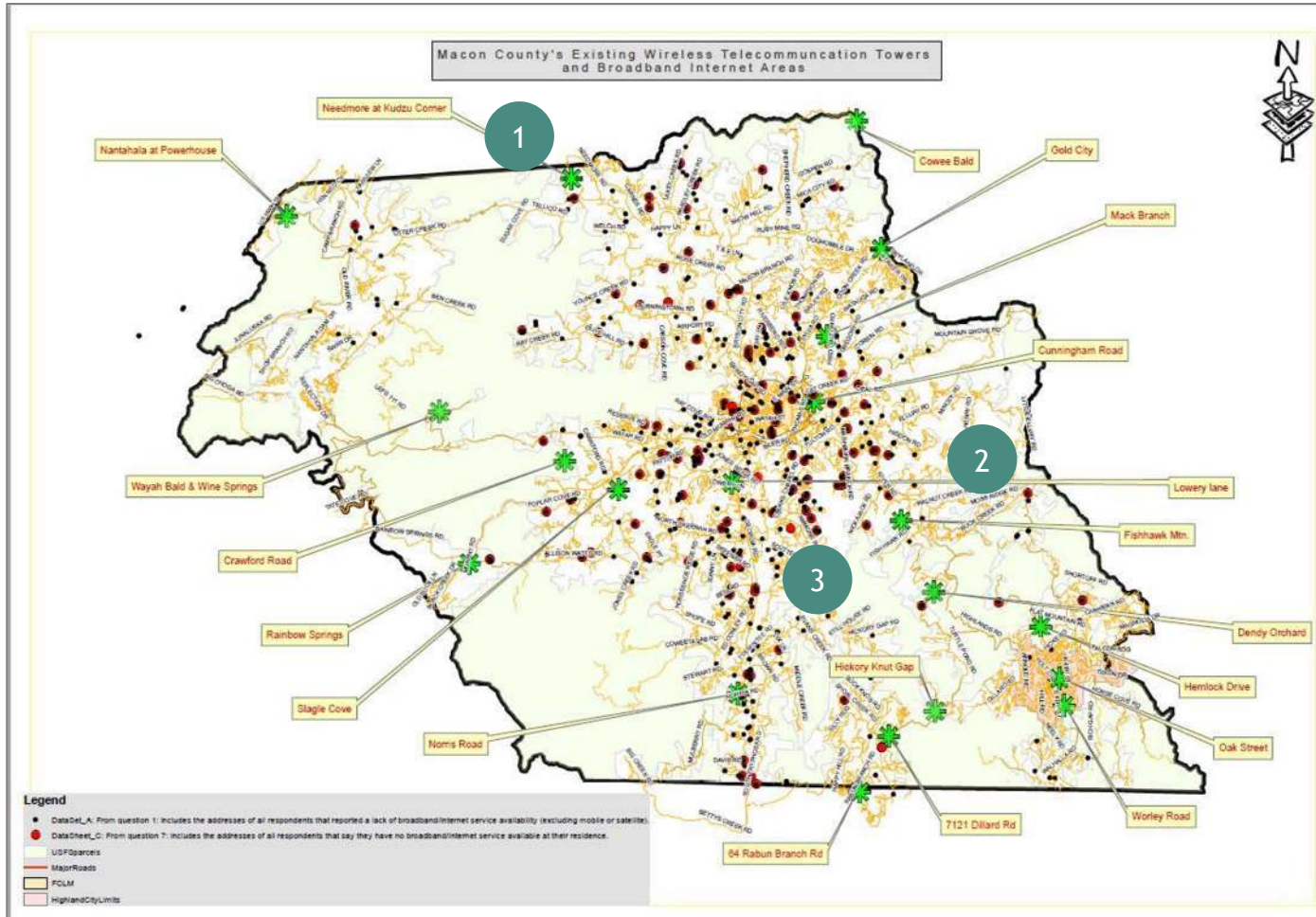

1 Hard assets
GIS data offers inventory of assets (e.g., buildings, water towers, capital projects, community-owned land, utilities)



2 Soft assets
Includes higher-ed institutions, civic groups, nonprofits, businesses and other organizations that offer expertise, volunteer support & advocacy experience



3 Underserved need
Red and black dots indicates where survey respondents reported a lack of internet access

Case study | Iowa - Signify Health Community Care Network

To address social determinants of health outcomes, Signify developed a statewide coordinated Community Care database that integrates social care with medical services by collaborating with local social service and state health organizations



Action tracker/resource portal

- Fragmented data collection process
- Difficulty tracking vulnerable, transient populations
- Maintaining privacy protections



26

Participating agencies and organizations



Community directory

- CBOs
- Health care plans/providers
- Non-profits
- Foundations
- Local governments
- State agencies



400K

Individuals identified in need of both clinical and social care



Community need dashboard

- Connect members to non-medical needs (e.g., transportation, housing and health management)
- Coordinate health and social services across organizations
- Track and measure both health /non-health patient needs
- Safely share patient information in a secure system



7M

Successfully completed services

Impact

LA Census Partnership Digital Equity Data Tracking

- City of LA partnered with Census's recent American Community Survey data to track digital divide
- Tracks computer and internet access, building infrastructure with small cell nodes, school and digital access and public wifi access points
- Users can use interface to create customized digital divide maps
- Links to GetConnectedLA where users can find information on accessing low-cost internet, computers and training sessions

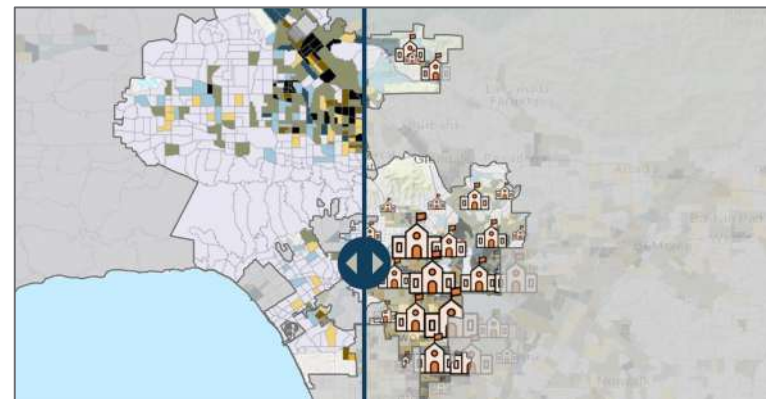

University of Chicago Tracking of CHI digital divide

Received grant from data.org to map Chicago digital divide

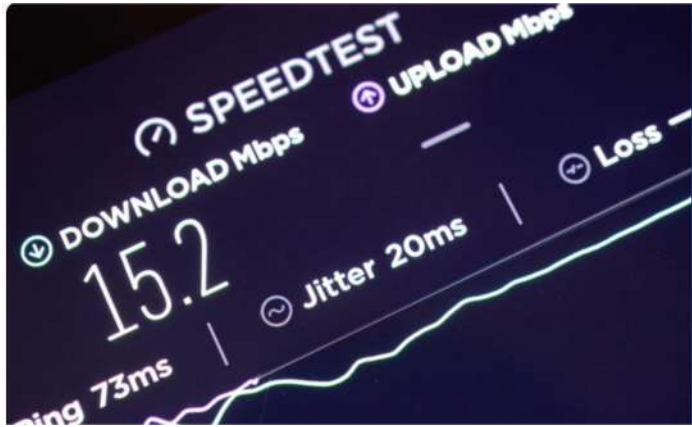

Will track indicators such as lack of fiber connectivity, to speed, to broadband access



Will use data science, machine learning and will gather data from communities and online resources

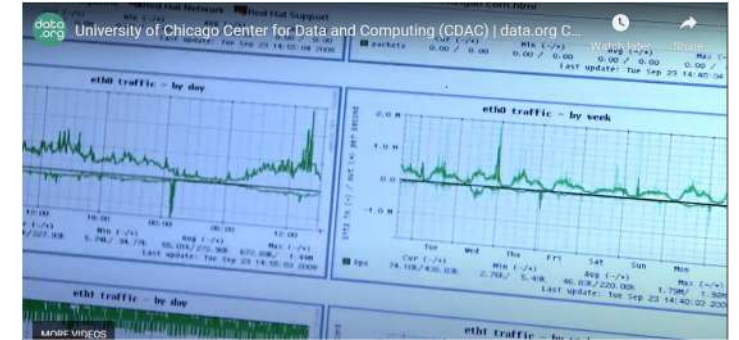

New York Digital Equity Survey

Received ~5K responses from teachers on student devices and digital access

SURVEY PARTICIPATION				
	Submitted	%	Not Submitted	%
Rest of State Public Schools	2,652	99.8%	6	0.2%
New York City	1,583	100%	0	-
Big 4	175	100%	0	-
853, 4201, 4410, and State Operated Schools	236	99.2%	2	0.8%
Charter Schools	289	88.9%	36	11.1%
BOCES	37	100%	0	-
TOTAL	4,972	99.1%	44	0.9%

Contains grade-level and other breakdowns of NYC and other cities

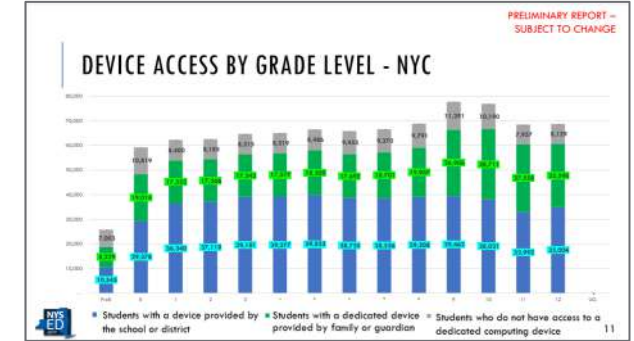

Have NYC specific data on student access to devices at home

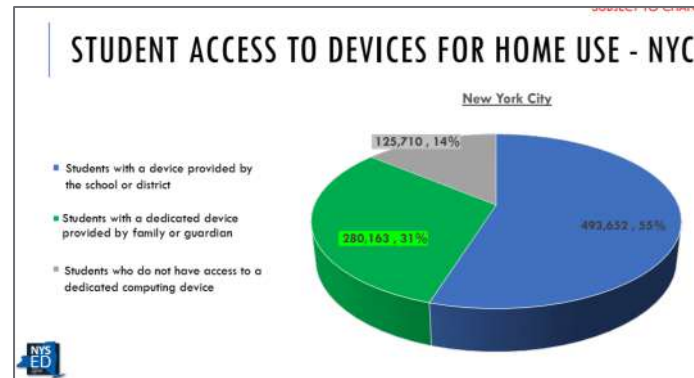

Learnings from the performance metrics of comparison cities and municipalities



Use performance metrics for two key reasons: (a) **internal improvement**, (b) **external transparency, call to action, and fundraising**

- **Seattle** released analysis that identified broadband gaps and called on city leaders, ISPs, community groups, to support residents



Work to understand **the most underserved areas** in the community through surveys and fiber maps

- **Philadelphia** is standing up a program with local ISPs to understand where households are disconnected with have the poorest bandwidths



Standup efforts to track **outcomes-based metrics** to better understand the true impact of digital programs

- **Chattanooga** is tracking data usage and **Ramsey County, Minnesota** analyzed the social ROI of its TechPak initiative















Measure a balance of **output metrics** (e.g., families connected, devices distributed) and **outcome metrics** (e.g., usage, digital literacy)

- **Chicago Connected** ran a survey highlighting how many students were connected and their engagement once logged on

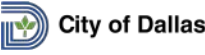







Example metrics used by cities across output vs. outcome measures

Illustrative, Non-Exhaustive

Often tracked **output** metrics

Metric	Examples
Students enrolled	  
Devices/hotspots distributed	 
Households connected	  (Houston)
Wi-Fi Extenders implemented	  (Portland)
Available infra. and speeds	 
New route miles of fiber	  (Chattanooga)

Often tracked **outcome** metrics

Metric	Examples
Data usage	 (Chattanooga)
Reasons for using internet	
Digital literacy	  (Portland)
Workforce training	 CITY OF KANSAS CITY, MISSOURI  (Portland)
Community orgs engaged	 CITY OF KANSAS CITY, MISSOURI 
Social ROI	 RAMSEY COUNTY

KPIs should measure both the technical progress of solutions and the outcomes/impact on the target population

State broadband offices have begun creating detailed dashboards with cities planning to follow suit

Illustrative, Non-Exhaustive

North Carolina Dashboard

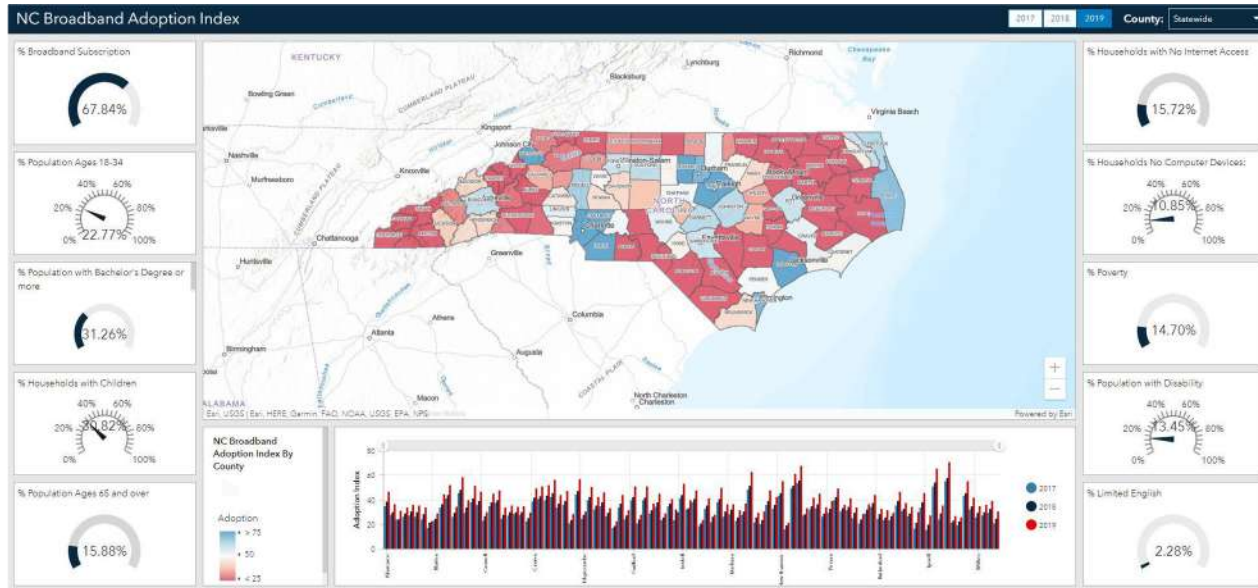

Arkansas Dashboard

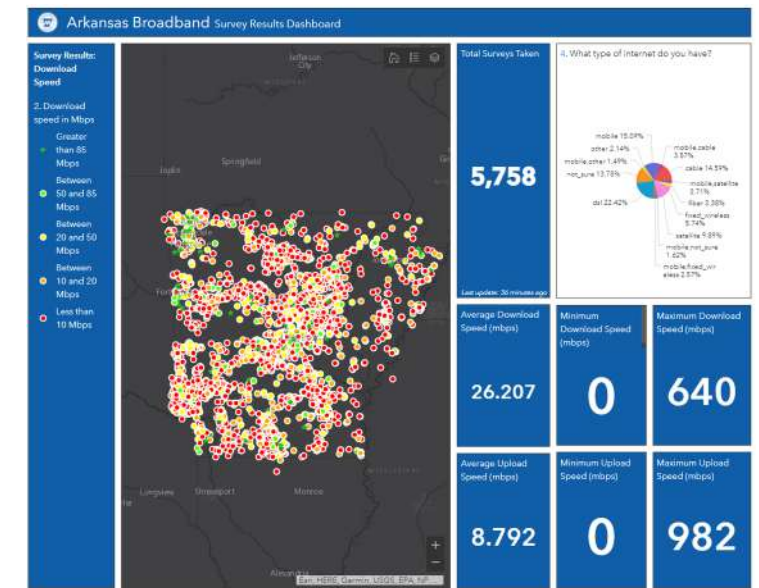

Adoption metrics tracked:

- Broadband subscription rate
- % Poverty
- % Population with Bachelor's
- % Population with disabilities
- % Households with children

Availability metrics tracked:

- % with 25/3 available
- % with 100/20 available
- % Population with fiber
- % Population with no ISPs
- % Houses build after 2010

Speed survey metrics tracked:

- Surveys taken
- Internet type
- Average upload/download speeds
- Min and max upload/download speeds

Seattle, Salt Lake City, Austin have indicated plans to evaluate digital inclusion on community dashboards

Next Century cities identified best practice output and outcome-oriented metrics

Dimensions to consider when measuring success of digital programs



Output Metrics

- Take rates:** Measure the overall number of households and businesses that have gotten online
- Diversity of institutions:** Determine if connectivity reaches all corners of the community



Outcome Metrics

- Financial stability:** Understand the sustainability of the business model based on take rates and returns on investment (e.g., public investment brings tangible and intangible benefits to the community)
- New businesses:** Measure if new companies have set up shop in the community/existing businesses take advantage of new opportunities
- Mutually beneficial partnerships:** Determine if partnerships have formed with stakeholders that maximize benefits and mitigate risk for all parties
- Engaged community:** Assess if the community involved is in and supportive of the project and if the work serves true community needs

Both **output and outcome-oriented metrics** are needed to understand the full narrative around the **impact of a coalition's work**

Texas A&M evaluation | Connected Beyond the Classroom data collection and visualization



Data dashboard

Utilizing data visualization software (e.g., Tableau) to create multiple data dashboards for real-time decision-making by school administrators with plans to develop public facing versions



Key performance metrics

Tracking over 50 KPIs covering infrastructure (e.g., internet speeds, equipment functionality) and household impact (e.g., parental engagement, academic improvements)



Surveys

Collecting over 20K survey responses from students, parents teachers, and administrators on digital access barriers facing students to design targeted solutions around them

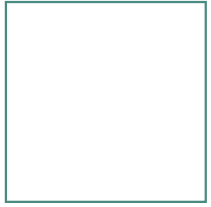

Recommendation

7

Data & analytics solutions

Detailed recommendations

- 7A Understand household level needs through surveys and direct usage data
 - Partner with Texas A&M on data evaluation and explore opportunities to scale data collection/analysis beyond students
 - Develop process for continuous online household surveying with embedded speed tests to stay current on the evolving needs of residents
 - Create feedback channels to continually improve data collection mechanisms
- 7B Build and maintain comprehensive database of 'hard' assets (e.g., fiber lines, light poles) sourced from existing (e.g., COSA permitting) and new mapping
 - Leverage city & county data collection/mapping of broadband infrastructure
 - Partner with organizations and companies specializing in mapping and asset assessment to verify and refresh data
- 7C Develop comprehensive inventory of community resources for digital inclusion
 - Develop process for continuous community inventory surveying
 - Crowdfund community directory of existing resources via grant applications
 - Encourage community members to continuously self-report data
- 7D Establish single source of truth to manage internal data collection/ownership and external data infrastructure (e.g., public dashboard, equity maps)
 - Develop aggregated data outputs (e.g., dashboard, online portal, mapping) to inform targeted solutions, track progress over time, and rally external support
 - Establish regular cadence of touchpoints to support information sharing and coordination across involved stakeholders
 - Create mechanisms for ongoing community/stakeholder engagement and plan activation (e.g., town halls, awareness campaigns, research reports)
 - Establish accountability and ownership for individual data pieces (e.g., maps) and tracking of key metrics

Data collection will evolve from proxies to direct inputs over time

Proposed categories of KPIs to assess SA/Bexar's digital strategy

Bold = topline metric to track

ROI

- **Social ROI on digital investments across local, state, and federal funding**
- Inclusive growth (e.g., employment rate, GDP, graduation rates, equity maps)
- Business-related KPIs (e.g., number of STEM graduates, digitally advanced city)
- Impact of broadband across other sectors (e.g., health, traffic)

Note: ROI metrics require add'l analysis to derive impact associated with broadband access

Increase Usage

- **Usage of digital across key use cases (e.g., workforce, telehealth)**
- Average GB usage per household and average speeds
- Digital standards and usage in education programs
- Digital skills/certifications (e.g., ability to navigate website, search the web)

Drive Adoption

- **# and % of households without home internet and/or devices (by segment)**
- % of households with physical infrastructure (across benchmark speeds)
- **# and % of households who cannot afford internet/devices (with gov. programs)**
- **# and % of households who have distrust in current digital programs**

Backup | Key metrics to be tracked across a variety of data sources and compiled on a centralized hub

Illustrative, Non-Exhaustive			
Category	Metric	Tracking Mechanism	Potential Source
ROI	Social ROI on digital investments across local, state, and federal funding	➤ Analyses from third-party companies to quantify Social ROI of digital equity programs	Analytics groups/companies
	City growth (e.g., employment rate, GDP, graduation rates, equity maps)	➤ Regression analyses to determine the impact of broadband (vs. other factors) on city growth metrics	Analytics groups/companies
Increase Usage	Usage of digital across key use cases (e.g., workforce, telehealth)	➤ Digital usage from standards from various use case organizations (e.g., SA Ready to Work)	Various community organizations
	Digital standards and usage in schools	➤ Connected Beyond the Classroom statistics and Local/Microsoft data around usage	City
Overcome Adoption	# and % of households without home internet or device (by segment)	➤ School/household surveys	Texas A&M, ESC20
	Enrollment in digital literacy/navigators programs (e.g., OATS)	➤ Reoccurring touchpoints with OATS and other Digital Navigator programs	Various community organizations
Overcome Barriers	% of households with physical infrastructure (across benchmark speeds)	➤ BroadbandNow, FCC, ACS data on household access, speed test data, local fiber maps	City/County (e.g., permitting, IT office), Connected Nation
	# and % of households who cannot afford broadband (with gov. programs)	➤ School/household surveys and ACS income data	Texas A&M, ESC20

Metrics to be tracked across different entities but brought together in a single dashboard

Performance metrics to be integrated across both a public facing dashboard and research reports

Illustrative, Non-Exhaustive

Dashboard Metrics

Tracks overall adoption and each leg of the stool to measure progress, improve coordination across stakeholders, and inform future solutions

Adoption: Overall broadband/device subscription rate across geographies

Availability:

- % of households with 25/3 and 100/20 available
- # and % of households with fiber access, miles of new fiber deployed
- % of households with no ISPs
- % of households build after 2010

Affordability:

- # and % of households that can't afford broadband (with gov. programs)
- % of households enrolled in Lifeline, other gov. programs
- % of households below the poverty line
- Broadband prices and service options (including low-cost options)

Devices:

- % of households with a device available
- Device prices (including low-cost options)

Adoption:

- # and % of households who have distrust in current digital programs
- % of households that speak limited English
- % of households with children
- % of population 65 and older
- % of population with disabilities

Research Report Metrics

Highlights the ROI of programs for future digital advocacy and fundraising

Return on Investment:

- Social ROI on digital investments across local, state, and federal funding
- Inclusive growth (e.g., employment rate, GDP, graduation rates) due to broadband access
- Business-related KPIs (e.g., number of STEM graduates, digitally advanced city)

Increase in Usage:

- Usage of digital across key use cases (e.g., workforce, telehealth)
- Average GB usage and speed per household
- Digital standards and usage in education programs
- Digital skills/certifications (e.g., ability to navigate website, search the web)

Community Engagement:

- Enrollment in digital literacy/navigators programs (e.g., OATS)
- Creation of partnerships and assessment of community engagement



Example Dashboard - Tracking Digital Equity Progress

Overall subscription rates for year, region, and population

Barrier

- Availability
- Affordability
- Devices
- Adoption

Year

- '18
- '19
- '20
- '21

Region

- Countywide

Population

- All populations

Bexar County Digital Divide Status

- Broadband: 78.4%
- Devices: 92.1%

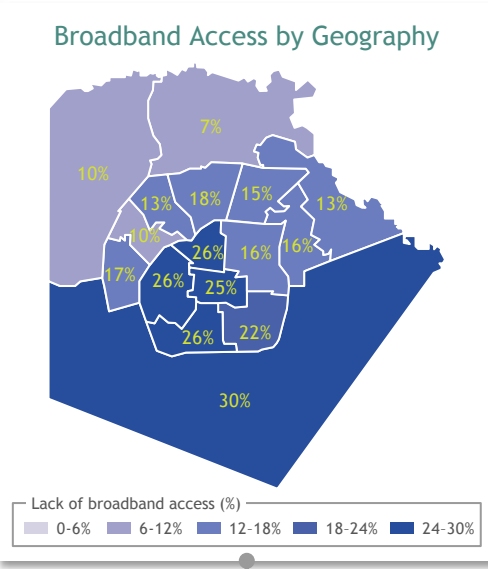

Metrics

- Households with 25/3: 94.3 (407K households)
- Households with 100/20: 76.1% (329K households)
- Households with fiber: 47.1% (310 miles of new fiber deployed)
- Households with no ISPs: 8.1% (35K households)

Ability to toggle dashboard across barriers, year, region, and population to assess desired demographic and fully utilize available data

Scrollable output-oriented metrics for the given barrier

Mapped visual of barrier status across the County

Several tactics should be employed to ensure that the defined KPIs are integrated across the community



Publicize KPIs on the community website with rationales for why each metric is being tracked



Report progress on defined KPIs on an ongoing basis through monthly/quarterly newsletters



Use KPIs in the economic narrative to support future requests for investment



Require grants applications to use the defined KPIs, ensuring that grantees track these metrics

Table of contents

3	Fact-base
4	Summary
6	Interviews and Community Engagement
19	Inventory Survey
28	K-12 Questionnaire
33	Size and Nature of the Digital Divide
47	ISP Economics & Engagement
56	Initiative Details
57	Infrastructure
93	Affordable Housing Access
104	Education Sponsored
127	Low-income Internet
149	Device Support
162	Adoption Support
191	Data & Analytics
214	Operating Model
244	Population Segments
250	Implementation Roadmap
273	Funding Databases
290	Asset Maps
291	Access Maps
294	Coverage Maps
300	Community Level Maps

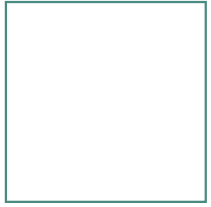

Nature of the problem

Summary | Overview of the current coordination model in SA/Bexar County



Digital equity has become an increasingly important issue in SA/Bexar County with **multiple organizations** engaging in efforts to bridge the digital divide



The city has often been pulled in to support these efforts, but in an **ad hoc manner** that added work to employees who already have full plates



The digital divide is an issue that **forces stakeholders to come together** in a coordinated way that they have not previously



A **dedicated digital equity program**, organized by a coordinating body, should be stood up to aggregate and maximize the ongoing efforts in SA/Bexar County

99 organizations surveyed serve a wide range of populations

survey respondents

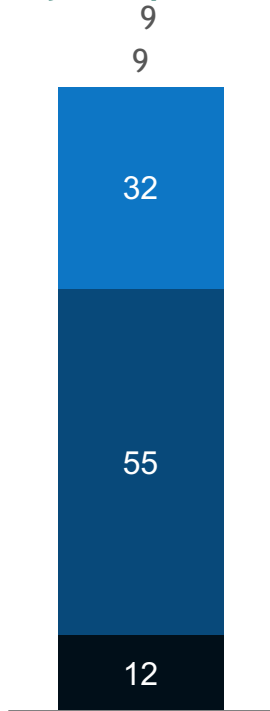

Public Sector
Social Sector
Private Sector

of organizations serving specific populations

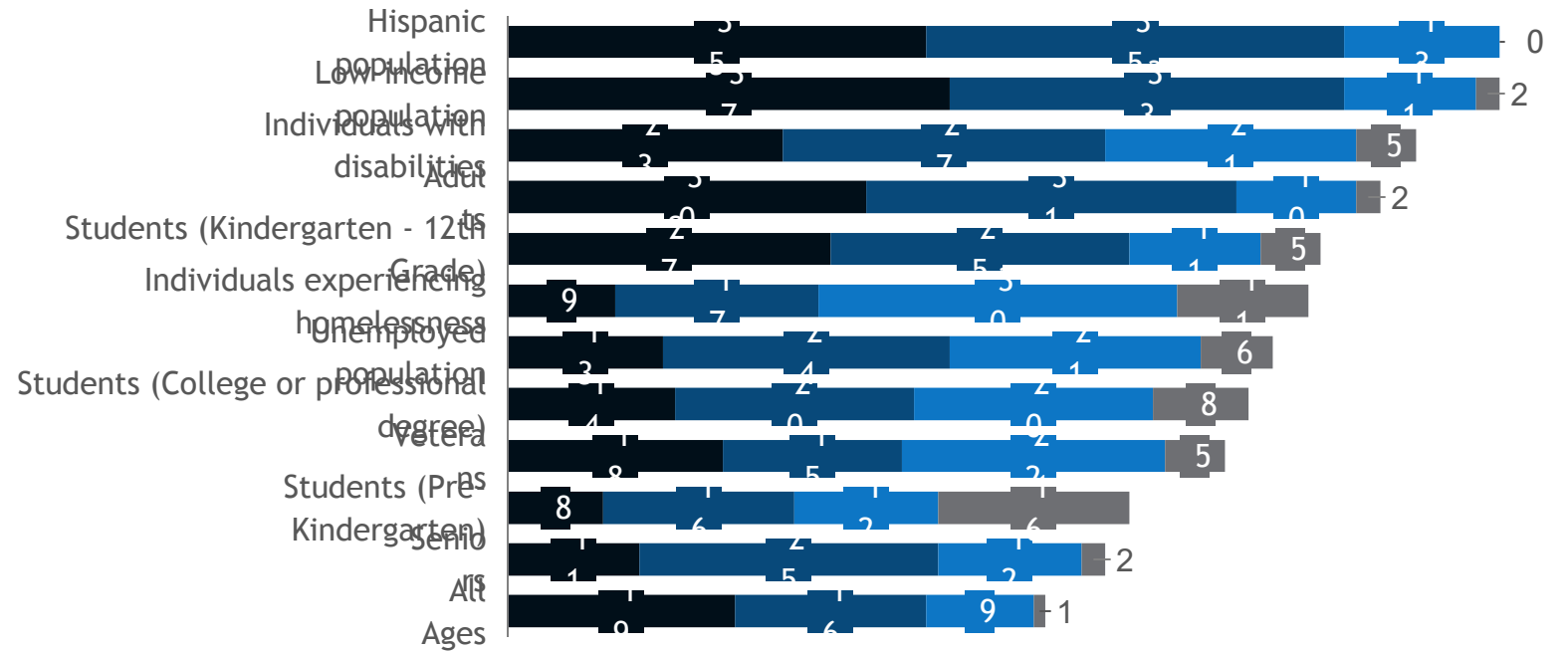

Primary recipient for our work
A key population we serve
A population we serve, but not our primary target
A population we rarely serve

More than 80 organizations offer a variety of digital inclusion services

of organizations offering digital inclusion services

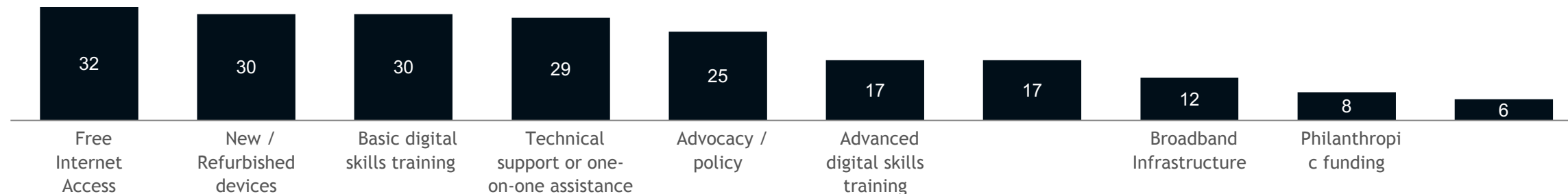

Why does your organization offer and invest in digital inclusion efforts?

- “ It improves **quality of life** for San Antonio area residents and contributes positively to the business climate-San Antonio Chamber of Commerce
- “ It is crucial for inclusion of the disabilities population-Southwind Fields
- “ There is a clear, **geographical digital divide** in San Antonio that needs to be addressed-Libraries Without Borders
- “ Consistent digital connectivity is critical to **help youth and their families access services, education, employment.**-Girls Inc. of San Antonio
- “ The poverty rate in this MSA is the highest in the country. Our students & prospective students need technology to put them on an even playing field. Education can drive social mobility but we need to equip our students for success. **There is no “productivity” without “connectivity”** -Alamo Colleges District
- “ Broadband/digital inclusion impact on **health equity and breaking the cycle of poverty.** As our VP, J Barton, has noted, Digital Inclusion is economic inclusion-Methodist Healthcare Ministries

Lesson learned from current state and efforts underway

There's a lot going on, but limited coordination

- “There's so much going on. We ran a survey back in April, but that's already almost a year old. We need do to a better job on outreach to know what demographics are served and how”
- We should know what groups are doing similar work to know where we're duplicating efforts and where gaps exist there's too much competition for funding stemming from not being aligned”

Invest in building a strong coalition

- “The [Dallas] coalition has been a critical component to success and driving progress; convening bi-weekly to has been useful for community groups to share information and express concerns/needs”
- “For a long time, the city [of San Antonio] has been trying to everything on its own. That's not going to be how we solve this problem. It's going to take collaboration, coordination, and partnership”

Prepare “shovel ready” projects/maximize funding

- “We're need our initiatives to be shovel-ready to apply for federal grants...we need to know where to use federal funding versus where to apply for a 10K CRA Bank grant”
- “Additional pilot programs might be needed to qualify for additional grants and demonstrate impact”

Ensure community involvement in solution

- “When you build programs or solutions for people instead of with them, it's harder to get them on board with whatever it is you're offering them”
- “Building relationships with community members comes before telling them what you can do for them; this happens informally through repeated interactions”

Assess the ROI/economic impact of digital inclusion efforts

- “We need metrics around money and return on investment in order to clearly communicate the value of digital inclusion to potential funders/other interested parties”
- “[Texas A&M SA] is creating consistent metrics which can be used to demonstrate quantitative impact”

Develop a shared fact-base

- “We need a clearing house of data to make sure everyone involved is looking at the same facts; ideally, it would be online for the larger public to access”

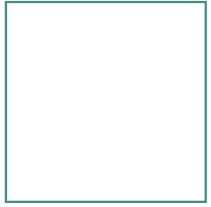

Comparison city research and local efforts

Key findings from relevant benchmarks for broadband and other service delivery



Majority of municipal broadband initiatives have historically been led at the city level, often out of financial necessity due to capital constraints

- Seattle's initial attempt at city-wide fiber network with Gigabit Squared failed due to inadequate funding



One persistent challenge of placing strategy ownership at the city-level is balancing broadband priorities with day-to-day activities

- New York is deploying digital equity initiative while simultaneously maintaining core IT infrastructure systems for 8M residents across public safety, human services, education, economic development, and more



Utilities have historically been an effective way to deliver basic services given their community focus and resilience to political shifts

- CPS serves all Bexar and portions of 7 surrounding counties while simultaneously supporting multiple community outreach programs



Non-profits can be catalysts for change but overall strategy is often managed by entities able to receive public and community funds

- Blandin Foundation conducts feasibility studies for Minnesota to help prepare state/federal grant proposals and identify areas for investment, which has helped the state lead in expanding broadband deployment

LA County-Digital Equity Regional Team Structure

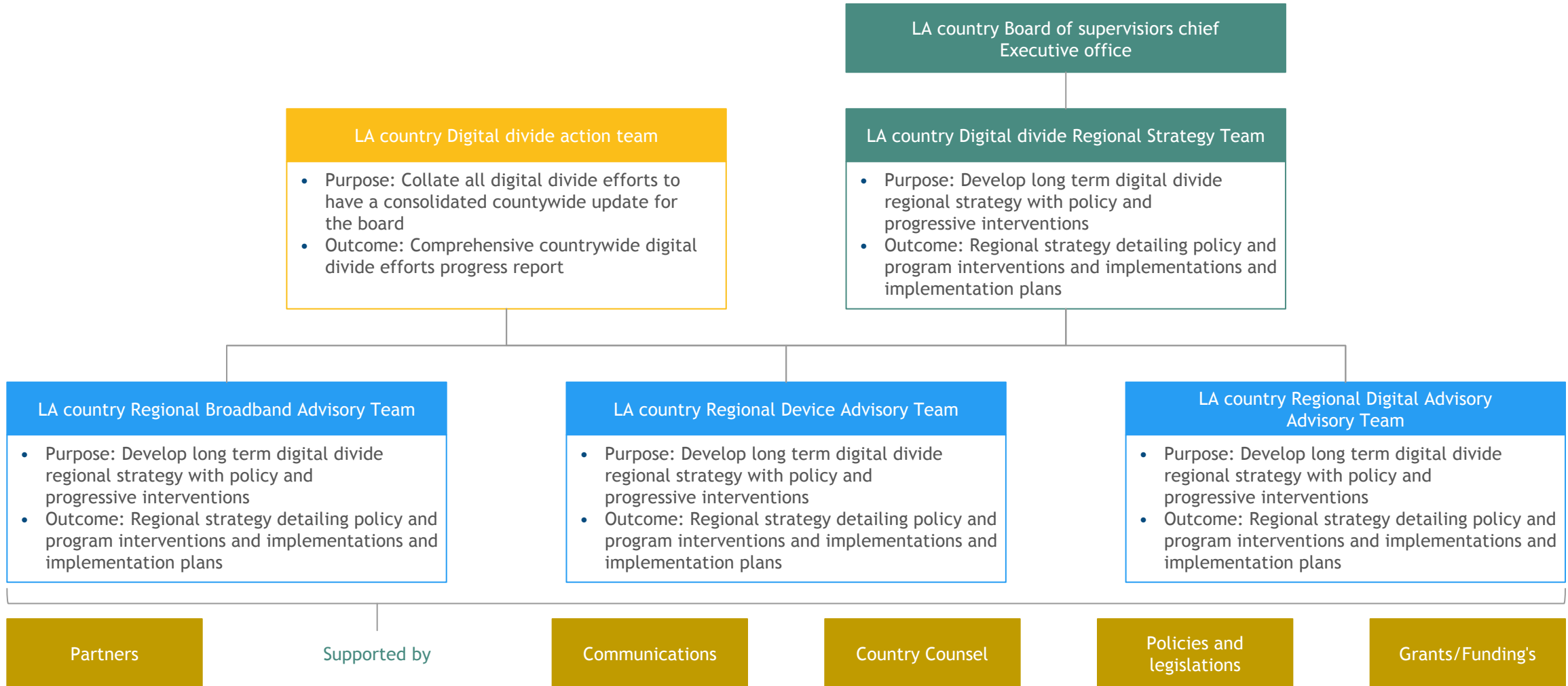

DC Office of the CTO

5 top priorities include “Partner to address the digital divide and help prepare for digitally-enabled jobs in the economic recovery”

	Legal D. Matties 3 FTEs/1 Vacant	Chief Technology Officer L. Parker 351 FTEs/32 Vacant		Agency Fiscal Officer P. Peng 10 FTEs		
OCTO Central C. Harrison 30 FTEs/5 Vacant	Security S. Cherukuri 10 FTEs/3 Vacant	Customer Experience Vacant 85 FTEs/11 Vacant	Data B. Krucoff 22 FTEs	Infrastructure A. Weldon 60 FTEs/3 Vacant	DC-NET H. Lofton 87 FTEs/6 Vacant	Applications S. Miller 43 FTEs/3 Vacant
Deputy Chief of Staff T. Faruk 5 FTEs	Engineering Ops 6 FTEs	Telecom Gov Vacant 10 FTEs/1 Vacant	Data Integration 2 FTEs	NOC L. Joseph 14 FTEs	DC-NET Warehouse A. Ahorrio 6 FTEs	Application Solutions C. Marshall 43 FTEs/2 Vacant
Communications N. Liggett 4 FTEs	GRC Vacant 2 FTEs/1 Vacant	OCTOhelps S. Todd 61 FTEs/8 Vacant	Data Curation M. Fields 6 FTEs	Mainframe G. Minter 23 FTEs/1 Vacant	DC-NET Ops T. Johnson 23 FTEs/4 Vacant	Quality Assurance M. Shibly 8 FTEs
Property Mgmt D. Johnson 5 FTEs/1 Vacant	SOC Vacant 1 FTEs/2 Vacant	Business Relationship Managers 2 FTEs/1 Vacant	Data Dev M. Sokol 7 FTEs	ECIS T. Evans 15 FTEs/1 Vacant	Voice Ops I. Joseph 24 FTEs/1 Vacant	DMV Vacant 7 FTEs/1 Vacant
Connect DC D. Squires 4 FTEs		Web Service M. Rupert 11 FTEs	Data Analytics M. Bentivegna	Citywide Messaging B. Augustine 5 FTEs/1 Vacant	ISP/OSP P. Noble 17 FTEs	PASS A. Damireddy 2 FTEs/1 Vacant
HCM Vacant 4 FTEs/2 Vacant					Engineering S. Singh 2 FTEs	PeopleSoft J. Pothireddy 9 FTEs
					Data Center Fac I. Gibson 6 FTEs	

Chicago Connected stood up a coordinated digital equity partnership across stakeholders



Early stakeholder engagement created program urgency

- Project began with authentic parent voice-Kids First Chicago elevated the voices of families impacted by the digital divide
- Chicago benefits from a history of investing in public school education
- Investments from Citadel and Crown Family Philanthropies spurred the launch of Chicago Connected
- Program raised \$50M to serve approximately 100,000 Chicago public school students



Chicago Connected partnership bridged coalition of stakeholders

- The City of Chicago led strategic vision to secure public and private funding
- Chicago Public Schools (CPS) determined eligibility and led daily operations
- Comcast and RCN served as broadband providers and T-Mobile served as the major cellular hotspot provider
- United Way of Metro Chicago and Children First Fund served as fiscal agents to ensure security/data privacy
- Kids First Chicago and 35 CBOs led community engagement efforts by serving as critical conduits to eligible families



Coalition unlocked multiple digital equity efforts

- Designed and executed a sustainable, sponsored service program to provide internet to eligible families
- Organized four years of funding, with philanthropy and CARES funding the first two years and CPS funding thereafter
- Led dedicated community outreach efforts to increase enrollment

Key themes from digital investment across benchmark municipalities

Preliminary



Leveraging existing communication infrastructure enables a low cost municipal broadband solution that can be implemented in a short span

- Pittsburgh's DragonNet cost the city \$1.2M and used existing CBRS network to provide free internet access to students in 40 days



Successful city digital investments complement existing educational initiatives, receiving financial support and community buy-in

- Philadelphia expanded its municipal broadband K12 initiative to include pre-K12 families, extending free internet access to new neighborhoods



Providing free broadband as part of smart city planning or digital infrastructure upgrades is a more scalable and effective solution

- Las Vegas free broadband network was deployed as part of the IoT solutions for city's streetlights among other smart city pilot programs



To ensure fiscal and legal compliance, the internet bandwidth should be limited, and filter out malicious or illegal content

- Boston offers free outdoor Wi-Fi in several public areas, but limits usage per device and limits user from accessing illegal content (e.g., gambling websites)

Other City Examples: City Digital Investment-(I/II)

City/ County	Stakeholder	Date	Initiative name	Amount Invested	Funding Source	Why did they do it	Description of actions
Pittsburg	City of Pittsburg, Pittsburg Community schools	2021	DragonNet	\$1.2M	<ul style="list-style-type: none"> Grants (public safety sales tax + utility funds) Strengthening People and Revitalizing Kansas (SPARK) task force 	<ul style="list-style-type: none"> Schools require access to dependable internet connectivity to support remote and hybrid learners, especially during the pandemic 	<ul style="list-style-type: none"> Antennas placed in schools and public places to provide connection to the district's network Used existing fiber optic cables that carry CBRS and was deployed in 40 days School monitors access to network and content through firewalls and filters
Las Vegas	City of Las Vegas, Clark County School district	2020	Innovate Vegas	Part of \$30M funds for smart city	<ul style="list-style-type: none"> AT&T, Ubicquia, and city funds 	<ul style="list-style-type: none"> Part of the smart city and innovate Vegas initiatives to promote mobility, public safety and economic growth 	<ul style="list-style-type: none"> Installed CBRS on disenfranchised area, created VPN and provided broadband connectivity to students through school-provided computers/tablets
State of Oregon	State, Oregon State University, Oregon Health & Science University, Portland State University, University of Oregon	2019	Link Oregon	\$8.39M for ramp up from federal grants	<ul style="list-style-type: none"> Initial funding through founding institutions, and longer-term financing through Oregon State University E-rate and Federal grants 	<ul style="list-style-type: none"> Enabling access to rural and remote communities facing broadband access challenges 	<ul style="list-style-type: none"> Provides network connectivity to K-12 and higher education, research and healthcare organizations, libraries, federally recognized tribes, and state and local government agencies Fiber capacity was sourced through existing telco providers, consolidating demand for fiber under one banner helped Link Oregon support network upgrades to rural communities

Source: <https://commenco.com/pittsburg-ks-pittsburg-community-schools-work-to-bridge-digital-divide/>; <https://www.fourstateshomepage.com/news/pittsburg-city-commission-approves-funding-for-wireless-program/>; <https://www.meritalkslg.com/articles/pittsburg-kan-looks-to-bridge-digital-divide-for-k-12-students/>; <https://urgentcomm.com/2020/09/16/ubicquia-prepares-to-expand-streetlight-based-small-cell-smart-grid-solutions-portfolio/>; <https://www.lv.net/Free-Downtown-Wi-fi.htm>; https://www.oregonlegislature.gov/citizen_engagement/Reports/OBAC%202020%20Report%2011-1-2020.pdf

Other City Examples: City Digital Investment-(II/II)

City/ County	Stakeholder	Date	Initiative name	Amount Invested	Funding Source	Why did they do it	Description of actions
Boston	City of Boston	2014	WickedFreeWif i	\$600K a year	<ul style="list-style-type: none"> Funded by Boston's general funds, and partners, including US Department of Housing and Urban Development's Choice Neighborhoods program 	<ul style="list-style-type: none"> Closing digital divide and enable access of internet to more families and businesses 	<ul style="list-style-type: none"> WiFi designed to work indoors Content is filtered to prevent access to malicious and illegal content, bandwidth is limited
Santa Clara	City of Santa Clara, Silicon Valley Power	2013	SVPMeterConn ect Wifi	N/A	<ul style="list-style-type: none"> Funding was by the city as part of the initiative to replace old electric meters 	<ul style="list-style-type: none"> Providing free digital literacy training, affordable internet service to those without access 	<ul style="list-style-type: none"> New electric meters provide free, outdoor internet Content is filtered to prevent access to malicious and illegal content, bandwidth is limited
Philadelphi a	City of Philadelphia, School District of Philadelphia	2021	PHLConnectED	\$17M	<ul style="list-style-type: none"> Funding and support by Community Learning Center, ExCiTe Center at Drexel university, and other community programs 	<ul style="list-style-type: none"> Providing access to families to support educational needs, during the pandemic 	<ul style="list-style-type: none"> Families need to qualify for service Dedicated 211 hotline to provide information, screen for eligibility and support

Source: <https://www.govtech.com/network/boston-launches-wicked-free-wi-fi.html>; <https://www.boston.gov/departments/innovation-and-technology/how-wicked-free-wi-fi-works>; <https://bunewsservice.com/bostons-free-wi-fi-doesnt-fill-promised-gaps/>; <https://www.nbcbayarea.com/news/local/santa-clara-gets-free-wi-fi-via-high-tech-meters/2049865/>; <https://www.philasd.org/technologyservices/gettingconnected/>; <https://www.phila.gov/2021-03-12-the-city-of-philadelphia-marks-one-year-anniversary-of-schools-closing-with-phlconnected-updates-and-milestones/>; <https://www.phila.gov/2020-08-06-city-of-philadelphia-launches-phlconnected-to-connect-k-12-students-to-the-internet-and-provide-tech-support-for-the-upcoming-school-year/#:~:text=This%20phase%20of%20PHLConnectED%20will,%248%20million%20in%20year%20two.>

COMP CITY RESEARCH

Municipal bonds can be a mechanism to expand broadband access



Call to action for bond usage

Municipal bonds have historically been used to finance public projects (e.g., roads, schools)

- Advocacy has grown around bond usage for digital inclusion



TechBloc CEO, David Heard, pushed for inclusion of digital infrastructure in San



Antonio's 2022 bond program



Forbes and Pew Trusts have advocated for the potential of municipal fiber bonds



Benefit of muni broadband bonds

- ✓ Enables city-sponsored digital infrastructure buildout, akin to roadways, power, water projects
- ✓ Creates public-private partnership between the city and ISP where residents are able to affordably repay the investment over time
- ✓ Lowers prices and improves services through ISP competition, incentivizing strong performance for contracts renewals



Examples of municipal bonds



Salt Lake City communities combined to finance a **fiber network to homes**, allowing **all service providers** to operate to lower service costs



New Hampshire towns have issued bonds to **construct fiber networks**, funding the bond payments through **~\$10 monthly subscriber fees**

Consider municipal bond model and take necessary local steps to include proposal for City council

Recent analysis projects significant social return on investment for the Ramsey County TechPak initiative



What is the TechPak Initiative?

- TechPak is an initiative that brought computers, internet, and digital literacy training to Ramsey County, MN residents who experienced economic impacts due to COVID-19¹
- The initiative is run by a cross-sector partnership of Tech Dump (device refurbisher), Literacy Minnesota (digital skills builder), Saint Paul Public Library (community touchpoint), and Ramsey County (coordinator)
- Packs include a refurbished laptop, a hotspot, and an assigned “digital navigator” to provide individual support; 2,150 TechPaks were awarded to residents from September to December 2020
- Ramsey County CARES Act funding financed the program (e.g., \$1.5K cost per TechPak)

1. Include job loss, reduced hours, change of household income or have other barriers due to COVID-19
Source: Ecotone Analytics



Positive Social Return on Investment

For every \$1 spent on the TechPak initiative, there is a projected \$2.40 in social ROI

- \$1.82 increased earnings, educational attainment, quality of life, mental health
- \$0.54 increased tax revenues
- \$0.04 reduced public-school costs
- Additional reduced climate risk

Projected \$3.7K lifetime benefit per recipient vs. \$1.5K cost per TechPak (including support)

Connecting half of the disconnected households in Ramsey County would yield upwards of \$25M in total benefits

Key themes from community activation efforts in benchmark municipalities

Preliminary



Successful activation programs **shape their initiatives around the community**, rather than reshape community around digital approach

- **Kansas City** initiative partnered with churches and local faith-based organizations to do literacy programs, as these are trusted community institutions



Philanthropic/private sector players can use their platforms to bring stakeholders together and build momentum for digital equity programs

- **Kids First Chicago** published a report that elevated the voices of families directly impacted by the digital divide to unlock private/philanthropic investment and stakeholder engagement to launch Chicago Connected



Activate digital equity plans through City/County websites, news/media press, and the voices of key stakeholders (e.g., Mayor)

- **San Francisco** formed a citywide digital equity initiative, publicizing their strategic plan and equity playbook through the Mayor's website and news articles to build program momentum



Offer **centralized resources such as playbooks or public portals** to engage local organizations and the community

- **Portland** enables community organizations to share information and helps residents get connected through a resource portal that includes a community directory and community need dashboards (**deep dive on next page**)

Portland's centralized resource portal serves as a best practice to replicate

In response to COVID-19, Portland's Digital Inclusion Network has been collaboratively working to overcome digital access barriers faced by underserved populations. As part of their efforts, tracking and disseminating data has been central

Action tracker/resource portal

- Provides a virtual space for information sharing and communications among community orgs involved in expanding access
- Captures on the ground experiences and resource needs to crowd-source solutions
- Shares information about connectivity, devices, technical support services, and funding support with community

Community directory

Provides publicly available information on the following:

- Areas to access public Wi-Fi
- List of low-cost internet providers/device programs
- Technical support/digital literacy courses

Community need dashboard

Integrates GIS maps of digital access and local efforts in order to:

- Measure and track impact
- Identify gaps in service and unmet need
- Track racial and socio-economic equity

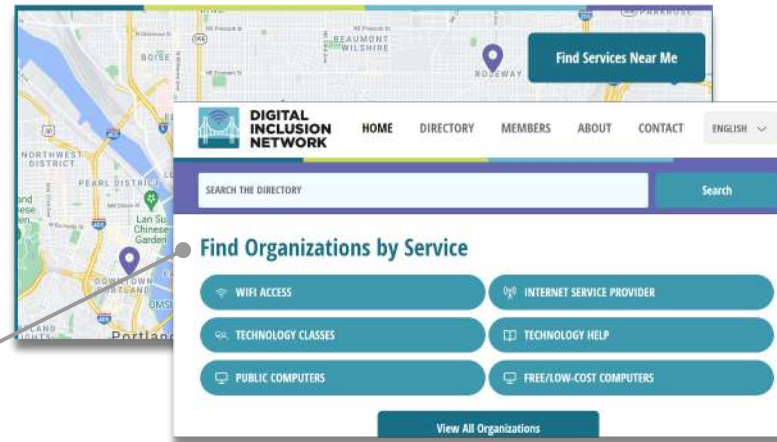

Services organized by household need with organizations ready to support each area

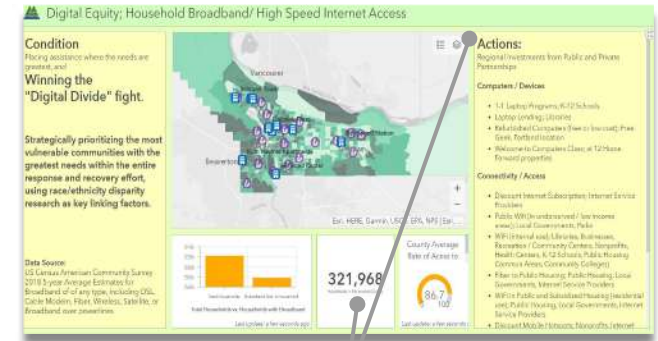

Provides status update of digital divide performance metrics with gaps prioritized for future action

Other City Examples: Community Activation-(I/II)

City/ County	Stakeholders	Date	Initiative name	Why did they do it	Description of actions
San Francisco	City of San Francisco, Community-based organizations	2019	SF Digital Equity Strategic Plan	<ul style="list-style-type: none"> Internet and technology is now vital necessity, but 100k San Franciscans lack broadband or basic digital skills 	<ul style="list-style-type: none"> Form coalition of community orgs to collaborate with to advance digital equity services Build tech capacity of community-based orgs to ensure partners can assist residents with tech needs Offer centralized resources like Digital Equity playbook and workshops for these orgs
Portland	City of Portland Gov, group of community stakeholders	2014-present	Digital Inclusion Network	<ul style="list-style-type: none"> To raise awareness of digital equity gaps and develop solutions 	<ul style="list-style-type: none"> Brought together group of community orgs and stakeholders to raise awareness of digital equity and develop solutions Share Digital Equity Action Plan with orgs and individuals to encourage adoption and support by CBO's school districts, and local businesses
Washington DC	District of Columbia CTO, non-profits, academic institutions	September 2015	Connect.DC	<ul style="list-style-type: none"> Previous plans have been successful with adoption rate increase from 58% to 76% '08-'13, but still much more room to grow 	<ul style="list-style-type: none"> Connect.DC partners with community-based orgs to generate content that addresses issues of non-adopters (e.g., an app that helps returning citizens find employers who hire those with criminal backgrounds) Partners with community organizations to offer tech courses and certification (e.g., Byte Back)
Kansas City	City of Kansas City MO, mayors office, local churches and community orgs	2017	Digital Equity Strategy plan (collaboration with faith-based and community groups)	<ul style="list-style-type: none"> Key groups who need digital equity cannot be reached through normal channels 	<ul style="list-style-type: none"> This is just one tenet of a larger strategy, but this part is.. Partner with churches to do digital literacy programs Get more tech in churches for year-round use with hot spots Goal is to fit into community rather than shape the community to current digital approach

Source: https://sfmohcd.org/sites/default/files/SF_Digital_Equity_Strategic_Plan_2019.pdf; <https://www.portlandoregon.gov/oct/73860>; https://connect.dc.gov/sites/default/files/dc/sites/connect/page_content/attachments/State%20of%20the%20Digital%20Divide%20Report.pdf; <https://www.digitalinclusion.org/wp-content/uploads/2020/07/DigitalEquityStrategicPlan.pdf>

Other City Examples: Community Activation-(II/II)

City/ County	Stakeholders	Date	Initiative name	Why did they do it	Description of actions
Austin	City of Austin	2014	Digital Inclusion Plan	<ul style="list-style-type: none"> Internet and technology is now vital necessity, but 100k San Franciscans lack broadband or basic digital skills 	<ul style="list-style-type: none"> Utilizing community partners and assets including.. Transportation-Public access labs and other facilities should be located near existing bus or rail stops Community Advancement Network: Advance digital inclusion as CAN goal that can be measured on Community Dashboard Community programs: encourage to update their institutional goals to reflect Digital Inclusion Strategy priorities.
Chicago	Chicago Housing Authority, community partners	N/A	CHA Digital Inclusion	<ul style="list-style-type: none"> Residents need digital access to seek employment, education, banking etc. 	<ul style="list-style-type: none"> Youth have opportunity to participate in CHI City of Learning coding challenges, and FUSE camps during summer Mobile technology van contains 30 laptops, and leads digital trainings, and can be found at parks and community events Chicago Digital Learn partnership with Public libraries offering courses in English and Spanish to build computer skills and confidence
Salt Lake City	Salt Lake City Council, Department of Public Services	2020	Engage and Include community	<ul style="list-style-type: none"> 13.3% of households in Salt Lake City have no internet and 5.4% have no computer 	<ul style="list-style-type: none"> Develop interactive community dashboard to access information from community and city government Build digital equity partnerships with city leaders, community members and local organizations

Source: http://austintexas.gov/sites/default/files/files/Digital_Inclusion_Strategy_ADOPTED.pdf; <https://www.thecha.org/residents/services/digital-inclusion>; http://www.slcdocs.com/council/agendas/2020agendas/September/1F/F1_Resolution_DigitalEquityPolicyofSaltLakeCity.pdf

LOCAL EFFORTS

CPS and SAWS offer models for effective service delivery through a public utility

<p>Service area</p>	<p>Serves all of Bexar County and portions of surrounding counties with a focus on sustainable, affordable access</p>
<p>Ownership and structure</p>	<p>Led by a CEO and supported by a cross-sector Board of Trustees with relevant expertise, appointed by City Council and Mayor</p> <ul style="list-style-type: none"> • CPS: Board members have backgrounds in cybersecurity, education, real estate, and law • SAWS: Board members have backgrounds in health care, finance, consulting, and academia
<p>Funding</p>	<p>Receives revenue for service fees charged to residents/customers and levies fees tied to impact and demand</p> <ul style="list-style-type: none"> • CPS/SAWS: Service extends to all Bexar and beyond due to demand aggregation incentivizing service • SAWS: Charges developers “impact fees”, based on the estimated average water demand, to ensure that new infrastructure extensions ‘pay their own way’
<p>Community engagement</p>	<p>Facilitates cross-sector partnerships with public, private sector, and non-profit stakeholders and engage community to understand their needed</p> <ul style="list-style-type: none"> • CPS: Series of committees and programs to understand concerns, offer financial assistance, and support community education • SAWS: Series of committees and programs to solicit feedback, convene CBOs and conduct broader philanthropic efforts

LOCAL EFFORTS

Local Efforts: Operating Model (I/II)

Organizations supporting advocacy/policy

- Texas Veterans Network
- UT Health San Antonio
- MICRO:SA
- Webhead
- North San Antonio Chamber of Commerce
- American Indians in Texas at the Spanish Colonial Missions
- Intercultural Development Research Association
- San Antonio Chamber of Commerce
- Bexar County Commissioners Court
- Southwind Fields
- Libraries Without Borders US
- Family Service Association of San Antonio, Inc.
- LISC San Antonio
- Voices for Children of San Antonio



Examples of how orgs have supported this initiative

- “ We support policies pushing for equity start up funding or incentives for existing companies. Big companies get the funding or existing nonprofits with very little impact to improve technical workforce skills-Webhead
- “ Our organization's focus is to support the business community/members and in doing so, we advocate for needed resources, including technology and availability of technology for employers' greatest assets, their employees-North San Antonio Chamber of Commerce
- “ We have advocated for funding and the creation of a broadband plan in the Texas Legislature, and encouraged our members to do the same-San Antonio Chamber of Commerce

LOCAL EFFORTS

Local Efforts: Operating Model (II/II)

Organizations supporting advocacy/policy

- UT Health San Antonio
- Webhead
- Bexar County Commissioners Court
- THRU Project
- LISC San Antonio
- City Education Partners

Examples of how orgs have supported this initiative

- “ We provide funding to purchase software, equipment, and training on specific software-LISC San Antonio
- “ We have fund raised and built a private wireless network that extends a school districts existing Internet connection into the neighborhoods and households directly surrounding for school sites in Edgewood ISD-City Education Partners



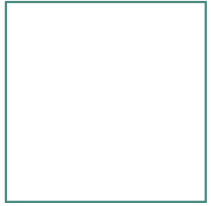

Recommendation

8

Operating model solutions

Detailed recommendations

Preliminary

- 8A Create the governance structure across public and private entities
 - Define the operating model, governance, and accountability to best leverage public assets/funding and private capabilities around community-based efforts
 - Organize around the public sector, acting on near-term initiatives and opportunities (e.g., ARPA), while pursuing a more durable structure of a utility
 - Sustain the cross-sector coalition that builds on the momentum of current efforts and carries work forward through close public sector partnership
- 8B Standup a digital equity team with sufficient resourcing to activate the strategic plan and carry the work forward
 - Develop resourcing plan to support peak activation and then steady state
 - Lineup teams for execution across initiatives with detailed workplans and charters that define owners, timelines, milestones and associated costs
- 8C Secure endorsement and funding for the plan and maintain the digital strategy and goals with a lens for equity
 - Obtain endorsement for the digital inclusion plan from stakeholders across the public, private and non-profit sectors by sharing the digital inclusion narrative
 - Unlock sufficient funding from federal, state, local, and philanthropic sources, advocating for the need by highlighting the ROI/cross-sector benefit of digital
 - Drive towards program milestones and long-term aspiration, prioritizing highest need populations to ensure digital access is expanded equitably
- 8D Engage the community to ensure buy-in and develop execution partnerships through multilingual and disability accessible forums
 - Setup reoccurring meetings and town halls to engage key local partners who are leaders in the digital equity community (e.g., SAPL, Texas A&M, OATS)
 - Compile a directory of digital inclusion entities and best practices on a community portal for the public to use

Our public-private-community partnership will champion the SA/Bexar digital equity plan and drive this work forward

Public-private-community structure

Plan Owners
Own the strategic plan and drive work forward

 City & County Leadership	 Cross-sector Coalition
--	--

Supporting Stakeholders
Leverage existing capabilities to support digital initiatives

 School Districts & Libraries	 State & Federal Policymakers
 Internet Service Providers	 Private Sector & Corp Foundations
 Community Organizations	 Philanthropies & NGOs

Key activities to drive digital equity

City & County leadership will make use of funding to organize and act on initiatives, partnering with key stakeholders on ownership and execution

The cross-sector coalition, SA Digital Connects, will galvanize support and funding for the plan and coordinate engagement across the community. We do so with SA Talent/SAEDF as our fiscal agent

Several models for consideration; community-owned utility uniquely positioned to own and drive strategy

Structure for ED	ED sits within municipal department and operates with funding and logistical support from city/county	ED runs a community-owned entity with funding and board representation from city, county and/or private funders	ED sits within an existing non-profit and partners with city/county, private, and community leads for activation
Options for COSA/Bexar	<ul style="list-style-type: none"> • COSA IT department • Bexar County IT department 	<ul style="list-style-type: none"> • CPS • New utility/co-op entity 	<ul style="list-style-type: none"> • Philanthropic/community organization (e.g., SAEDF)
Considerations	<ul style="list-style-type: none"> ✓ Incrementally builds from current staffing model ✓ Facilitates ability to both direct and receive public funding ✓ Intricately ties broadband strategy to public priorities ✓ Closely links initiatives with supporting functions (e.g., permitting, help desk) 	<ul style="list-style-type: none"> ✓ Facilitates ability to receive public capital but maintains financial separation from city/county ✓ Cements broadband as a priority, not subject to political whims ✓ Maintains managerial flexibility through independent governance 	<ul style="list-style-type: none"> ✓ Facilitates strong advocacy and public promotion of broadband initiatives ✓ Enables fluid engagement across various sectors (e.g., local govt., CBOs) ✓ Provides additional insulation from bureaucratic/political pressures

Recommended

Within the utility model, potential to leverage new or existing structure

	Existing entity	New entity
Description	Create a specialized subsidiary within existing electrical utility	Establish a new entity funded by public sources with an independent board
Considerations	<ul style="list-style-type: none"> ✓ Leverages deep expertise in managing a complex infrastructure network ✓ Closely connects to existing investment (e.g., 800 miles of CPS-owned fiber) ✓ Provides existing asset base (e.g., call centers poles, bucket trucks) that can lower costs through transfer pricing 	<ul style="list-style-type: none"> ✓ Enables dedicated focus on the objectives of broadband access with broadband-specific expertise (e.g., service issues, workforce skillsets) ✓ Separates broadband delivery model (e.g., open access) from energy model (e.g., residential provider) ✓ Separates potential legal challenge associated with municipal broadband provision from utility energy provision
		Best fit approach

Preliminary operating model proposal for a utility

What is the organizational construct/set of constructs needed to get the work done?



A new **community-owned utility** is responsible for the overall accountability & execution of the broadband strategy

What is the scope of the work and objectives to be accomplished?



The remit spans the full range of what is needed - **creating a call to action, engaging stakeholders, actively seeking funds and executing initiatives** (including infrastructure investment)

Where does overall accountability for the broadband strategy reside?



The overall **accountability lies with the new utility**; the board of trustees, with representation from the city, county, community and experts, holds the utility accountable for meeting community needs

How do we keep a cross-sector coalition of stakeholders engaged throughout?



The utility keeps stakeholders engaged through the **board of trustees, multiple forums for community engagement, and a commitment to transparency and info sharing**, all with the support of strong community partners

Three inputs considered to identify resourcing needs

- 1 **Benchmarked Sources**
 - Examined the structure and operating model of broadband offices in other states (e.g., Illinois, Minnesota, Colorado) and exemplar cities/counties
- 2 **SA/Bexar County Initiatives**
 - Incorporated the work for our ten initiatives and resources required to complete them
- 3 **Advisory Group**
 - Leveraged key players in the SA/Bexar County digital landscape to identify key elements of a high-quality digital equity team **(quotes from discussion to the right)**

Advisory Group Input

“When everyone owns the implementation, no one owns it. It might not be one person, maybe it's a group, but they need to **wake up every day fully focused** on solving this problem”

“We need a **city-wide field-organizing approach**, with someone at the center who is aligned to community values and adds capacity”

“In order to do any of this to work, we need **mutual accountability across all partners ...** from a team that is representative of our community”

“We need resourcing against each initiative. Successful implementation **comes down to staffing**”

Table of contents

3	Fact-base
4	Summary
6	Interviews and Community Engagement
19	Inventory Survey
28	K-12 Questionnaire
33	Size and Nature of the Digital Divide
47	ISP Economics & Engagement
56	Initiative Details
57	Infrastructure
93	Affordable Housing Access
104	Education Sponsored
127	Low-income Internet
149	Device Support
162	Adoption Support
191	Data & Analytics
214	Operating Model
244	Population Segments
250	Implementation Roadmap
273	Funding Databases
290	Asset Maps
291	Access Maps
294	Coverage Maps
300	Community Level Maps

Closing the Digital Divide | E-Justice

Challenges

- Defendants and plaintiffs in online court are more likely to be digitally excluded or illiterate if unemployed, uneducated, disabled, elderly, homeless, indigenous or rurally located
- Those who are digitally excluded and unable to access justice have a greater likelihood of experiencing legal problems

Organizations already involved

Microsoft: Partnered with Argentine courts to develop an online portal that allows users to upload/download legal documents with digital signatures verified by Azure Active Directory

Zylab: Software company that creates digital knowledge platforms for both law firms and government entities which make it easy to obtain, view and use information

Solutions



Assisted digital support

- Offer multi-channel technical support that is tailored to different user needs, including face-to-face support, telephone help and web-chat assistance



Expansion of mobile access

- Create intuitive mobile applications for accessing justice services that focus should be on digitally excluded people for whom mobile devices provide a ubiquitous and affordable internet access point



Enhanced data gathering

- Conduct end-to-end pilots of online justice services, learning how best to meet that needs of participants at each stage of the justice process
- Research how people behave in an online environment and choose between assisted digital channels
- Collect and make available the widest range of data possible to support research by external experts

Closing the Digital Divide | Workforce development

Challenges

- As intelligent technologies (e.g., Big Data, AI, etc.) continue to proliferate, many workers face a **double disadvantage**—a higher risk of technological disruption from automation and fewer resources to embrace new career pathways
- **60%** of employers think that less than **25%** of their workforce is ready to work with new technologies and machines
- Today's skilling ecosystem focuses on the unemployed or those entering the workforce for the first time, rather than those at risk of becoming unemployed

Organizations already involved

The Markle Foundation: Developed an initiative to help American workers and employers adapt to the digital economy by fostering the adoption of skills-based talent management practices

Opportunity@Work: Increases economic mobility for underrepresented segments of the workforce by expanding inclusive, skills-based hiring among employers

Solutions



Career mapping

- Help workers **envision a different future** for their careers by exposing them to new career options, learning pathways, types of support and resources, and peers who have successfully made the same transition



Future-proof skills

- Facilitate a mutual transformation of expectations between employers and employees so workers receive the time, funding and support necessary to access **lifelong learning** opportunities



Putting skills into practice

- Enable workers to build work history and **'test drive'** new job opportunities / skills through short-term work placements that provide real value to employers



Networking

- Sustain workers' drive for lifelong learning by connecting them to skill-sharing, mentorship, networking and peer-to-peer support

Closing the Digital Divide | Telehealth

Challenges

- **34 million** Americans lack access to fixed broadband at speeds of at least 25 megabits per second (Mbps) for downloads and 3 Mbps for uploads
- **22%** of Americans in rural areas and **28%** of Americans in tribal lands lack broadband coverage—as opposed to **1.5%** of Americans in urban
- People with **communication-related disabilities** may not be able to use video-based, remote services, leading to some telehealth initiatives reinforce rather than narrow the digital divide

Organizations already involved

La Union del Pueblo Entero (LUPE): Health on Wheels (HoW) program along South Texas border meant to broaden access to health care in low-resource communities

Methodist Healthcare Ministries: developed the Turning Point pilot program for diabetic patients that uses a smartphone digital app to monitor diabetes progress and offer real-time support

Solutions



Understand how the digital divide manifests in community

- Perform a simple digital needs assessment to screen for digital access and literacy during patient intake as well as collect patient demographic information



Make telehealth offerings accessible to vulnerable patients

- Offer phone / virtual visits outside of traditional working hours to increase access for essential workers and patients who lack access to video technology



Connect patients with the technology necessary for virtual visits

- Share low-cost broadband options in area with patients (e.g., Lifeline, Internet Essentials, etc.)
- Help connect patients who struggle to use manual technology with adaptive alternatives (e.g., assistive keyboards or mouse alternatives)



Build patients' digital literacy

- Partner with local community organizations, such as public libraries and community centers, to offer digital literacy courses



Raise community awareness of telehealth offerings

- Market the availability of telehealth options across multiple communication channels that will reach vulnerable patients

Closing the Digital Divide | Veterans

Challenges

- One of the pressing issues facing Veterans in rural communities is the lack of **fast, reliable internet service**, or any internet service at all
- According to VHA's Office of Rural Health, **42%** of rural Veterans enrolled in VA do not have internet access that would support their use of VA telehealth and other online services

Organizations already involved

Walmart and Philips: Set up remote clinics—known as Atlas sites—for Veterans to access telehealth services closer to their homes as well as lending iPads to Veterans without home internet

T-Mobile: Connected Veterans to their health care providers on a secure line from any location on all devices with free T-Mobile service that used up none of their data

Solutions



Mapping

- Undertake detailed mapping effort of available broadband in rural areas to develop an accurate data set of resources that can be dedicated to unserved communities where the need is greatest



Satellite technology

- Invest in **satellite internet connectivity** for rural areas that either have little to no available broadband or are cost prohibitive regarding potential buildout of fiber networks



Fixed wireless solutions

- Deploy **fixed wireless technologies** to cover the last mile to the customer where specific features of surrounding landscape or terrain (e.g., miles of wilderness or farmland) make deploying fiber prohibitive



Deliver low-cost connected devices

- **Wireless providers could offer bundling services** that would offer low-income subscribers connected devices with embedded Wi-Fi/other connectivity options at no additional cost
- **Business and community partners can be encouraged to help provide devices** for residents to connect to the internet

Closing the Digital Divide | Access for Seniors

Challenges

- **One-third** of adults ages 65 and older report they've never used the internet, and **half** don't have internet access at home
- Of those who do use the internet, **nearly half** say they need someone else's help to set up or use a new digital device
- Even within their age group, there is significant variation in skills linked to people's education, income and autonomy of use, creating a "**second-level digital divide**"

Organizations already involved

Little Brothers Friendly of the Elderly: Tech Allies program offers older adults the opportunity to learn how to use a tablet device through an 8-week training course

Teeniors: Tech-savvy teens and young adults who help seniors learn technology (smartphone, computer, software) through one-on-one, personal coaching

Solutions



Goal-directed learning

- Research shows that that most older people have a **strong motivation to learn new skills** and to continue living fully through learning
- In order to get older adults to learn a new tech skill or more fully engage with technology, **they must see a clear reason for it**



Patient practice

- Teaching older adults new tech skills requires time, patience and practice. When teaching older adults digital skills, **a well-written set of steps** are crucial to remind older people how to use a new skill online
- The **ability to practice new skills** is also key. Ideally, older adults would attend regular classes and be supplied with a tablet/laptop to practice on during the week



Tackling discomfort

- Though some older adults may express a lack of interest in technology, this can reflect an **underlying fear of technology and lack of skills** rather than a true lack of desire to use digital tools
- Appropriate training can help to quell those fears and generate interest by making the **elderly more comfortable with digital tools**

Table of contents

3	Fact-base
4	Summary
6	Interviews and Community Engagement
19	Inventory Survey
28	K-12 Questionnaire
33	Size and Nature of the Digital Divide
47	ISP Economics & Engagement
56	Initiative Details
57	Infrastructure
93	Affordable Housing Access
104	Education Sponsored
127	Low-income Internet
149	Device Support
162	Adoption Support
191	Data & Analytics
214	Operating Model
244	Population Segments
250	Implementation Roadmap
273	Funding Databases
290	Asset Maps
291	Access Maps
294	Coverage Maps
300	Community Level Maps

Overview of plan accountability and activation

Our effort is working towards developing a broadband and digital equity ownership plan and roadmap for the community of SA / Bexar. We are aiming for a singular plan, with the support of all the key stakeholders across the public, private and social sectors behind it

As we think about the op model, including accountability and activation of this plan, we are pushing on two fronts

First, **how the public sector can organize and begin to act on initiatives** given near-term needs and opportunities (e.g., ARPA), while pursuing **setting up a more durable structure of a utility to carry it forward**. The near-term focus of this effort will be on:

- Determining a detailed plan of action to expand digital access (e.g., fiber investment) given influx of funds
- Hiring / dedicating the resourcing capabilities and standing-up the structure needed to get the work done
- Partnering with key stakeholders, including ISPs and community organizations, on shared ownership of initiatives
- Owning detailed mapping of fiber lines and other hard assets to inform infrastructure build-out

Second, in parallel, **how we will organize and sustain the cross-sector coalition** that builds directly on the momentum of our current effort and carries it forward, partnering closely with the public sector. The near-term focus of this effort will be on:

- Advocating for the needed investment across sectors to make the plan a reality
- Continuing to engage the community, build trust and galvanize support for our plan
- Coordinating information sharing (e.g., resource portal) and action across stakeholders (e.g., Ed & public sector)
- Raising philanthropic funding to support execution
- Holding the public sector accountable, including tracking KPIs and maintaining a pulse on the "state of broadband"

Backup | Responsibilities to be driven individually and together across the public and private sector teams

What the public sector owns

- Hire / assign resourcing to get work done
- Allocate City / County funding to key programs
- Build out infrastructure
- Own mapping of fiber lines / other hard assets
- Pursue more durable structure of a broadband utility

What is shared

- Define op. model and governance
- Drive shared ownership of digital initiatives
- Align on messaging and priorities of the unified plan

What the private sector owns

- Advocate for additional investment across sectors
- Engage community and build trust for our plan
- Coordinate information sharing (e.g., portal)
- Engage philanthropies and ISPs for programming and funding
- Hold the public sector accountable, including tracking KPIs

Three key actions needed in the near-term to make the plan a reality



Secure funding across available buckets

Isolate the needed funding uses and appropriate sources; take necessary actions to secure broadband-earmarked funds across sources



Obtain key stakeholder endorsements

Ensure support from key stakeholders (e.g., funders, advisors / community leaders, mayor, judge, city/county reps) to champion the plan and advocate for investment



Identify who can carry the baton forward

Identify who in the near-term (i.e., before ED is hired) can be responsible for each of the key action items needed for plan activation

Secure Funding

An estimated investment of \$600M over the next 3 years and \$90M annually thereafter is needed to close the digital divide

One-time (through Dec '24) and ongoing funding required to fully close the SA/Bexar Digital Divide

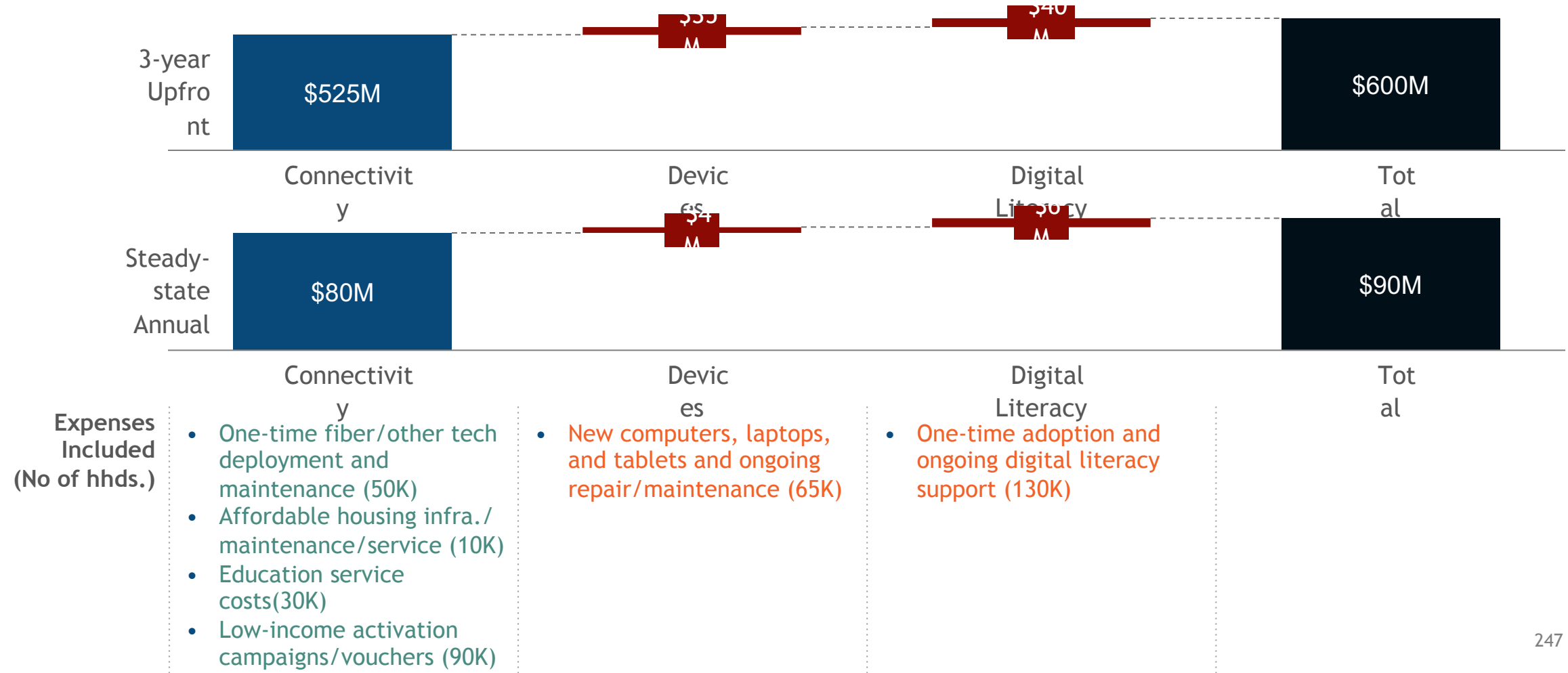

Preliminary, to be refined

Rationale for 3-year upfront (through Dec '24) and steady state annual costs

Priorities	3-Year Upfront	Steady State Annual	Initiative & associated costs	Household Reach
Access	~\$525M	~\$80M		
	~\$400M	~\$40M	Infrastructure Deployment: <ul style="list-style-type: none"> Deploy middle mile fiber and run a reverse auction to provide residential service of 100/100 speeds (\$400M) Support maintenance of fiber infrastructure (\$40M) 	210K hhds.
	~\$15M	~\$4M	Affordable housing connectivity¹: <ul style="list-style-type: none"> Invest in connectivity through SAHA and affordable housing entities by deploying infrastructure (\$5M) and covering service (\$10M) Maintain infrastructure (\$1M) and continue coverage of service costs (\$3M) 	10K hhds.
	~\$25M	~\$9M	Education Sponsored¹: <ul style="list-style-type: none"> Conduct connectivity purchasing, largely through ECF in the first year (\$25M), and then cover ongoing service costs (\$9M) Engage in device purchasing through ECF and 1:1 district programs, as well as ongoing repair and maintenance costs through service contracts Stand up support desks and adoption resources through school IT departments 	30K hhds.
	~\$80M	~\$27M	Low-Income Internet: <ul style="list-style-type: none"> Drive activation campaigns for existing programs like EBB and Lifeline (\$40M) Manage a SA / Bexar County specific voucher program (\$40M) Develop and expand sponsored service programs (\$27M) 	90K hhds.
Devices	~\$30M	~\$4M	Device Support²: <i>(incl. education / affordable housing)</i> <ul style="list-style-type: none"> Create grants for philanthropies to refurbish and distribute devices (\$15M) Drive device donation campaigns through private sector / philanthropy (\$15M) Cover repair and maintenance of devices (\$4M) 	65K hhds.
Digital Literacy	~\$45M	~\$6M	Adoption Support²: <i>(incl. education / affordable housing)</i> <ul style="list-style-type: none"> Drive adoption campaigns to enroll households in available programs (\$25M) Set up digital literacy programs through trusted community orgs (\$20M) Continue to support and expand digital literacy and skilling programs (\$6M) 	130K hhds.
Total	~\$600M	~\$90M		

Includes cross-cutting costs of ~\$5M 3-year upfront and ~\$2M steady state annual for a 10-15 person team and data & analytics costs

1. Non-connectivity costs sit in the respective devices and digital literacy rows. 2. Device and adoption support also cover education and affordable housing populations (e.g., through 1:1 purchasing / service contracts and citywide activation campaigns / Digital Navigators programs)

Preliminary, to be refined

Backup | Potential 3-year upfront & steady state annual funding sources (I/II)

		<i>Bold = Proposed funding source to leverage</i>	Illustrative
Access	Infrastructure deployment	Upfront: \$400M	<ul style="list-style-type: none"> Municipal bond: Utilize a bond to cover the high upfront costs of infrastructure State recovery: Advocate for state matching programs for infrastructure City / County recovery: Incentivize fiber buildout through reverse auctions
		Steady State: \$40M	<ul style="list-style-type: none"> ISPs: Cover maintenance costs in return for public capital investment State budget: Apply for grants through the state broadband office to cover maintenance City / County capital budget: Pay for required maintenance, potentially through utility
	Affordable housing connectivity	Upfront: \$15M	<ul style="list-style-type: none"> State recovery: Advocate for provision of internet in affordable housing City / County recovery: Fund connectivity infrastructure and service costs Philanthropy: Continue to support the standup of affordable housing connectivity
		Steady State: \$4M	<ul style="list-style-type: none"> SAHA Budget: Cover connectivity costs through annual budget (e.g., grants) City / County affordable housing budget: Cover infra. maintenance and service costs
Education sponsored	Upfront: \$25M	<ul style="list-style-type: none"> Federal programs: Leverage ECF to provide students with devices / connectivity ESSER / GEER: Use sector-specific funds to connect students 	
	Steady State: \$9M	<ul style="list-style-type: none"> Federal government: Advocate for an expanded E-Rate program School district budgets: Cover service costs / device maintenance for students 	
Low-income internet	Upfront: \$80M	<ul style="list-style-type: none"> Federal programs: Use EBB to connect low-income residents to highspeed internet City / County recovery: Standup voucher program for when EBB ends 	
	Steady State: \$27M	<ul style="list-style-type: none"> ISPs: Negotiate affordable pricing, potentially in return for capital investment Federal government: Advocate for an expanded Lifeline program City / County budget: Cover cost to continue voucher program 	

Preliminary, to be refined

Backup | Potential 3-year upfront & steady state annual funding sources (II/II)

		<i>Bold = Proposed funding source to leverage</i>		Illustrative
Devices	Device support	Upfront: \$30M	<ul style="list-style-type: none"> City / County recovery: Create grants for philanthropies to purchase / distribute devices Philanthropy: Collect and refurbish donated devices 	
		Steady State: \$4M	<ul style="list-style-type: none"> ISPs: Negotiate service contracts to cover ongoing cost of repairs and maintenance City / County budget: Pay for required devices maintenance 	
Digital Literacy	Adoption support	Upfront: \$45M	<ul style="list-style-type: none"> City / County budget: Cover upfront adoption campaign costs State recovery: Stand up adoption and digital literacy programs City / County recovery: Fund City / County wide adoption campaigns Philanthropy: Support one-off awareness campaigns 	
		Steady State: \$6M	<ul style="list-style-type: none"> State budget: Apply for grants to cover ongoing digital literacy program costs City / County budget: Cover ongoing digital literacy programs 	
Cross-Cutting	Data & analytics	Upfront: \$1M	<ul style="list-style-type: none"> NTIA Connecting Minority Community: Apply for grant to fund data & analytics costs Texas A&M: Use university funds to build data capability City / County recovery: Cover data & analytics costs 	
		Steady State: >\$1M	<ul style="list-style-type: none"> City / County budget: Cover data & analytics costs 	
Cross-Cutting	Operating model	Upfront: \$4M	<ul style="list-style-type: none"> Philanthropy: Cover employee salaries for first three years City / County recovery: Cover employee salaries for first three years 	
		Steady State: \$1M	<ul style="list-style-type: none"> City / County budget: Cover ongoing employee salary 	

Preliminary, to be refined

3-year upfront funding asks across major available buckets

Breakdown is illustrative - infra. could be funded through a mix of recovery funds / city budget or entirely through a bond, depending on the flexibility and likelihood of obtaining respective funding buckets

Illustrative
☆ One-time funding opportunity

☆	Federal programs (ARPA)	\$65M	\$50-100M	<ul style="list-style-type: none"> Education Sponsored: \$25M Low-income Internet¹: \$40M 	<ul style="list-style-type: none"> ➤ Conduct activation campaigns to get residents signed programs (e.g., EBB, ECF)
☆	State Recovery (ARPA)	\$125M	\$50-150M	<ul style="list-style-type: none"> Infrastructure Deployment: \$100M Affordable Housing: \$5M Adoption Support: \$20M 	<ul style="list-style-type: none"> ➤ Coordinate with Bexar County state legislative delegation to advocate for broadband priorities
☆	City / County recovery (ARPA)	\$65M	\$50-100M	<ul style="list-style-type: none"> Affordable Housing: \$10M Low-income Internet²: \$40M Device Support: \$15M 	<ul style="list-style-type: none"> ➤ Pursue endorsements and necessary City / County conversations to secure funds in the second tranche of ARPA funds
	State broadband office	\$0M	\$0M	<ul style="list-style-type: none"> N/A 	
	City operating budget	\$25M	TBD	<ul style="list-style-type: none"> Adoption Support: \$25M 	<ul style="list-style-type: none"> ➤ Advocate for incorporation of adoption campaigns into the city's general fund
☆	Municipal bond	\$300M	TBD	<ul style="list-style-type: none"> Infrastructure Deployment: \$300M 	<ul style="list-style-type: none"> ➤ Coordinate actions to raise importance of bond to Council and the voting public; identify sponsors for matching
	Philanthropy / NGOs	\$20M	TBD	<ul style="list-style-type: none"> Device Support: \$15M Operating Model: \$4M 	<ul style="list-style-type: none"> ➤ Continue 1:1 outreach with specific asks for investment, highlighting the social ROI
	Private Sector / Foundations	\$0M	TBD	<ul style="list-style-type: none"> N/A 	
	Total	\$600M	\$150-350M+		

Potential to investigate additional funding sources and grants (e.g., NTIA) to cover initiative costs

1. Assumes EBB will last 18 months given current usage rates. 2. Extension of EBB to potentially reduce the funding required to cover low-income internet

Obtain Endorsements

Path forward to obtain key stakeholder endorsements

1	Funders (i.e., Toyota, HEB)	Share strategic plan details in weekly meetings	
2	Advisory Committee		Support, champion, and publicly advocate for the plan
3	Community Organizations	Host town halls, focus groups and 1:1 discussions to share efforts	
4	Mayor		Prioritize digital inclusion as an agenda item
5	County Judge	Sequence 1:1 meetings facilitated through existing relationships to share plan, framed around members' specific interests (e.g., smart cities, urban dev., ed.)	
6	City Council		Prioritize and earmark funds for broadband (e.g., ARPA, city budget, bond)
7	County Commissioners		
8	Bexar County state legislative delegation	Align broadband strategy with state funding priorities	Prioritize and earmark funds for broadband (e.g., ARPA)
9	COSA Dept. Mgmt. (IT, Office of Innovation)	Conduct joint comparison and alignment of agendas with relevant staff leads (TBD based on input from city reps)	Align broadband strategy and city/county agendas, including budget prioritization
10	Bexar County Department managers		
11	Chambers of Commerce	Host session to share strategic plan details	Include digital inclusion in their city/county scorecards

Key questions

Who are the most **influential stakeholders for each funding stream** (state, county, city)?

What is the **right sequencing** of conversations?

When should these conversations take place?

Who are the **"trusted voices"** who are best positioned engage each stakeholder?

Support for digital and social equity has come from the SA City Council

District	Name	Why Digital Matters	Owner
District 1	Mario Bravo	"The unemployed and underemployed in our city are our number one focus... We need to... make sure that we are training for jobs that meet local needs "	TBD
District 2	Jalen McKee-Rodriguez	"One [Council Consideration Request] is a right to internet ordinance that would establish municipally owned broadband that would make it accessible to everyone"	TBD
District 3	Phyllis Viagran	"I believe closing the digital divide is critical. I'll work to bring broadband infrastructure to our neighborhoods"	TBD
District 4	Adriana Rocha Garcia	"Dr. Garcia has a passion for working with organizations that help San Antonio's most underrepresented demographics "	TBD
District 5	Teri Castillo	"Now is the time to take bold action and build on existing home rehabilitation programs, historical tax credits, and use public funds for the working people of San Antonio"	TBD
District 6	Melissa Cabello Havrda	"I want to facilitate rehabilitation and new construction incentives for housing... and offer high-quality infrastructure and technology options "	TBD
District 7	Ana Sandoval	"By using the concept of equity to guide our infrastructure investments, we aim to ensure that we provide every SA resident a minimum level of service and quality infrastructure"	TBD
District 8	Manny Peláez	"Digital inclusion initiatives are a big priority of mine... we plan to launch [a pilot program] to increase accessibility to LTE internet to K-12 "	TBD
District 9	John Courage	"I'm also a huge proponent of having our City be a better supporter of K-12 education... The better educated our workforce is , the stronger our City and economy will be"	TBD
District 10	Clayton Perry	"SA also has the reputation for being one of the poorest and most economically segregated cities in the country... we need to do more to help our small and microlocal businesses "	TBD

Each council member needs an owner (e.g., Anita, Luisa, Brian, DeAnne) to start the digital equity conversation

Identify timeline and owners

Key milestones for the SA / Bexar digital strategy to implement and achieve over the next 5 years

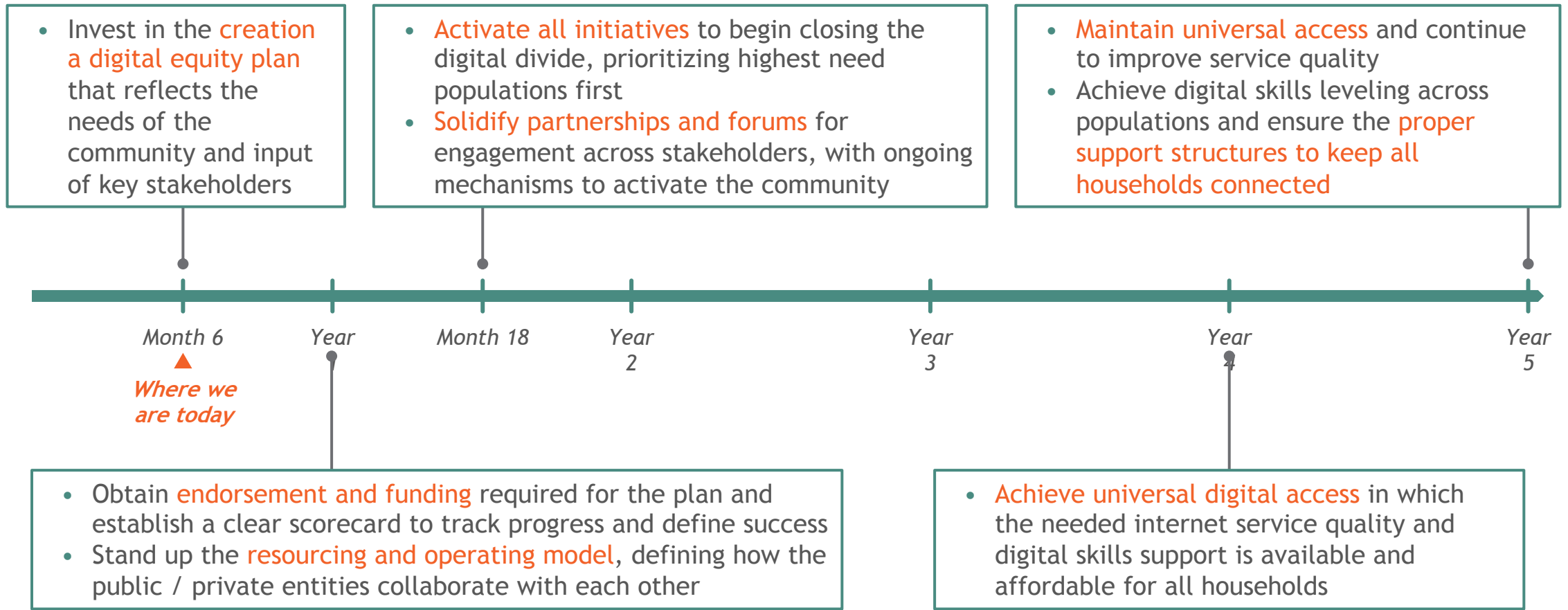

We have identified key performance measures to track progress against our strategy and will capture key metrics on a public dashboard

Key performance measures

- 1 **Access:** Households using home internet and devices at the service quality standards
- 2 **Availability:** Households with infra. access at 100/ 100 and avg. speeds at committed rates
- 3 **Affordability:** Households who have access to internet options that cost <1% of their income
- 4 **Adoption:** Households comfortable/motivated to adopt (e.g., no discomfort w/tech reported)
- 5 **Equity:** Relative access across geography and population segments (education, income, etc.)
- 6 **Peer Performance:** Ranking vs. other cities (e.g., National Equity Atlas)

Additional analyses are needed to assess the societal benefit attributed to digital access (e.g., GDP impact, business formation)

Example metrics dashboard

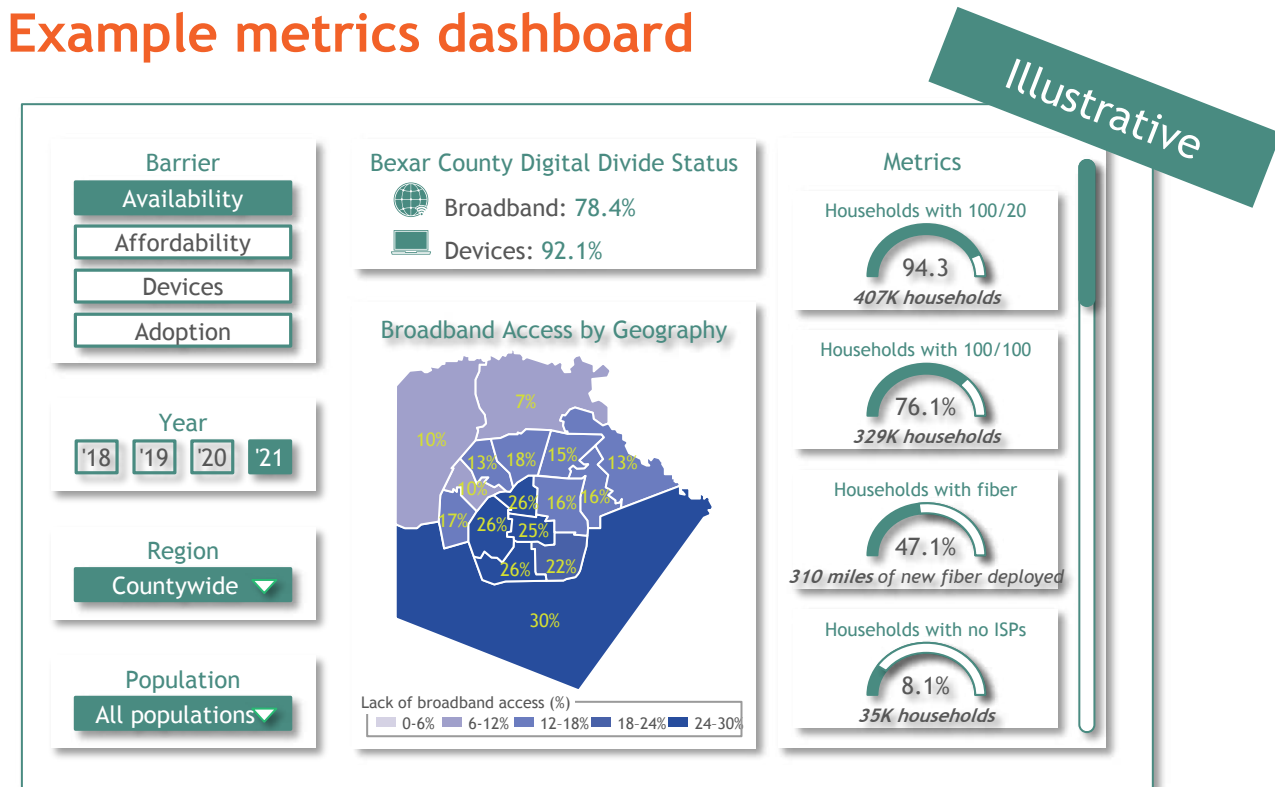

Dashboard to include the ability to toggle across barriers, year, region, and population







Our public-private-community partnership will champion the SA / Bexar digital equity plan and drive this work forward

Public-private-community structure

Cross-Sector Coalition
Own the strategic plan and drive work forward

 City & County Leadership	 Philanthropic & Private Leaders
---	--

Supporting Stakeholders
Leverage existing capabilities to support digital initiatives

 Education Instit. & Libraries	 Local, State & Fed Policymakers
 Internet Service Providers	 Private Sector & Corp Foundations
 Community Organizations	 Philanthropies & NGOs
 Residents and households of San Antonio / Bexar County	

Key activities to drive digital equity

The plan is a **single strategy, jointly owned**; together, we will collaboratively implement initiatives and optimize funds for the best possible outcome

City & County leadership will make use of funding to organize and act on initiatives, partnering with key stakeholders on ownership and execution

The philanthropic & private sector leaders of SA Digital Connects will galvanize support and funding for the plan and coordinate engagement across the community, partnering to ensure the public sector maintains action & funding on digital access. We do so with SA Talent/SAEDF as our fiscal agent

Achieving our goal requires cross-stakeholder support, engagement, and implementation



City, county, state, and federal policymakers to prioritize and unlock sustainable funding for digital equity and enabling regulation/policy



Private sector to champion the need for digital investment and help implement digital initiatives (e.g., STEM programming, infra. nodes)



Service providers to ensure solutions can be provided affordably and reliably



Community organizations to elevate the needs of the community and serve as key points of contact to drive adoption and support digital skills



Ed entities (K-12, higher ed, libraries, workforce dev) to expand digital/tech curriculum and serve as focal points for data collection and execution



Philanthropies to catalyze investment and support ongoing research, data collection, and execution towards closing the digital divide

All stakeholders must come together and leverage their unique expertise to sustainably close the divide

Four buckets of near-term action steps to activate the plan

Owner Group	Outcome	Activities	Owner (Proposed)
Shared (Coalition + Public)	Release plan to the public	1 Prepare the narrative for publication (e.g., content, design)	Candelaria, Anita
		2 Finalize other materials including collateral and FAQs	Candelaria, Anita
		3 Translate all relevant materials into Spanish	Candelaria, Anita
		4 Determine press strategy (e.g., news outlets, email listservs) to publicize plan to community	Candelaria, Anita
		5 Determine event structure (e.g., press vs. stage) and plan event(s) to coincide with the plan release	Candelaria, Anita
		6 Release plan and make it publicly available on the City website for future reference	Candelaria, Anita
Coalition (Philanthropic/ Private Sector Leaders)	Secure all needed endorsements	7 Identify authors and signers of the plan	Diane
		8 Obtain buy-in from our funders and advisory committees	Anita
		9 Coordinate & obtain endorsements from City Council, Commissioners, Mayor, County Judge	Diane
		1 Engage key community orgs to solicit input and build support/endorsement for the plan	Anita
	Formalize coalition structure	0 Share plan with households/community (including through City GPA platform)	Anita, Candelaria
		1 Socialize plan with ISPs and solicit input so that they endorse (at min. do not oppose) the plan	Diane, Luisa
		1	
		2 Run PMO where advocacy / private sector actions are needed to secure funding from identified sources	Diane, Anita, Luisa
		1	
		3	
		1 Manage hiring and onboarding of the Executive Director	Diane
		4 Select and hire the Executive Director	Funders
		1 Define the timeline , meeting cadence, roles, and stakeholder groups for the coalition	Diane, Anita
		5 Assign members of community orgs to serve on each coalition group	Anita, Candelaria
		1	
		6	
		1 Plan events to ensure ongoing engagement with community orgs (e.g., town halls)	Anita
		7	
		1	
		8	
		1 Create and share an preliminary MoU between the City and County to define plan ownership	Brian, Diane
		9 Take ownership and refine initiatives as needed to get into the form for funding proposals	Brian / Candelaria
		2 Determine path forward on public investments options (e.g., open access, public rebate, bond)	Craig, Brian
		0 Utilize City/County asset maps to inform strategy and determine next steps to refine mapping	John R.
2 Partner with ISPs on the tech requirements needed to inform the RFP / procurement process	Craig, Brian, John		
1 Finalize investment needs and align funding sources to the required uses	Brian / Candelaria		

Note: Diane to [OB all activities, as relevant](#); Laura to [determine best County engagement points of contact](#)

Proposed timing for first-year activities

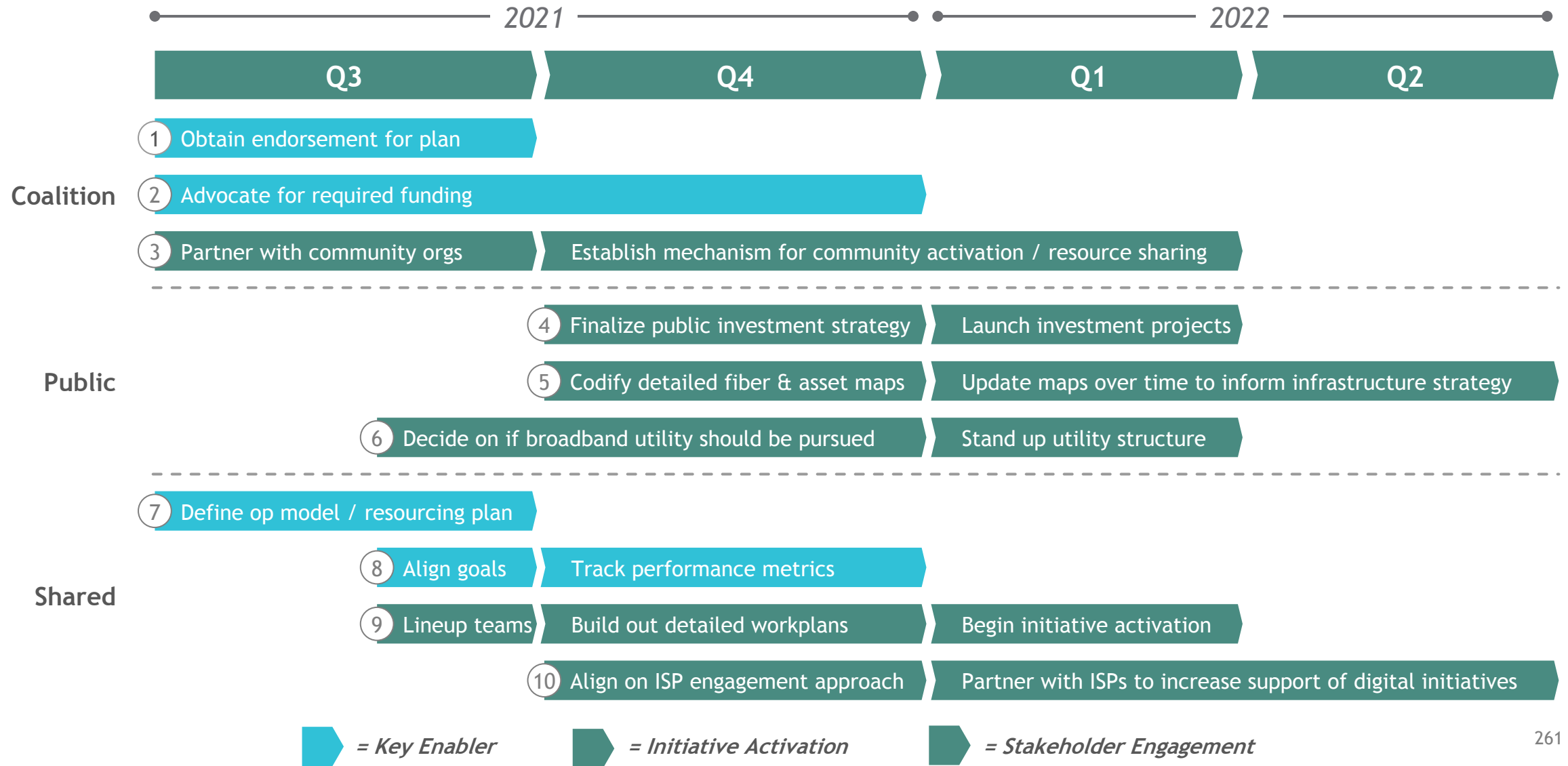

Timeline of key activities and initiative tasks against 5-year outlook

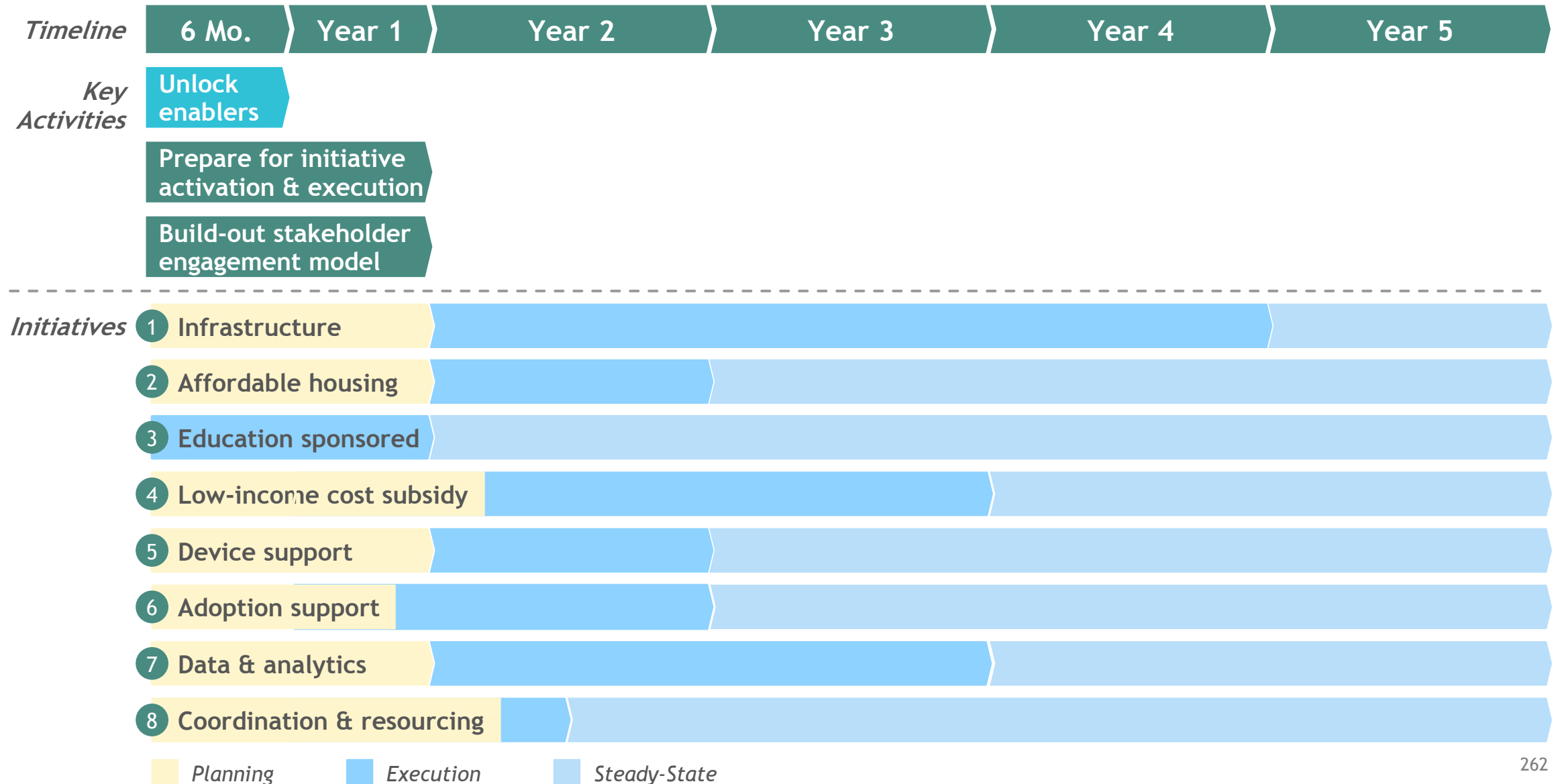

Digital Divide Initiative Scope benchmarks

City	\$ spent	# of people served	\$ per individual / household	Scope
New York	\$157M	600K underserved residents	~\$250 / individual	<ul style="list-style-type: none"> Largest sum made at city level, investment in 5G for all \$75% of new 5G light poles in underserved area, allowing telecom companies to reserve 7,500 poles for 5g and track franchisees to make sure using minority owned business
Chicago	\$50M	100K students	~\$500 / individual	<ul style="list-style-type: none"> Provide free internet to 100k student in households for minimum of four years
San Jose	\$24M	50k households	~\$500 / household	<ul style="list-style-type: none"> Connecting 50k households with universal access and connectivity, as well as offering digital skills classes
Detroit	\$23M	51K students	~\$450 / individual	<ul style="list-style-type: none"> Giving 51K students computer tablets and internet connectivity by end of 19-20 school year \$17M on tablets, \$6M on internet access
Chattanooga	\$8.3M	12k students and counting	~\$700 / individual	<ul style="list-style-type: none"> Rollout of fiber deployments at no charge to families with k-12 students who qualify for free lunch over ten years
Tulsa	\$5.6M	2,500 families	~2,200 / family	<ul style="list-style-type: none"> Bringing high-speed wifi to all Tulsa Housing Authority complexes, providing one free year
Charlotte	\$3.25M	2,000 households +	~\$1,600 / household	<ul style="list-style-type: none"> Invest \$1.5M to provide public wifi network in pilot sites in select public spaces and residential areas (~2,000 households) Invest \$1M to provide internet connectivity for remote learning at CMS network schools \$750K for learning labs and digital navigator programs
Newark	\$2.5M	6,600 students	~\$400 / individual	<ul style="list-style-type: none"> Wanted to use \$2.5M in grant money from federal gov to buy 6,600 new devices and hotspots, but didn't receive the money
Sacramento	\$1M	10,000 households	~\$100 / household	<ul style="list-style-type: none"> Collaborated with United Way and other orgs to offer free broadband access to 10K households affected by pandemic
San Diego	\$500K	N/A		<ul style="list-style-type: none"> Free Wi-Fi at 300 new locations, hundreds of new laptops to check out from libraries, 900 new mobile hotspots

Source: Sources from previous pages <https://durkan.seattle.gov/wp-content/uploads/sites/9/2020/09/Internet-for-All-Seattle-Report-FINAL.pdf>; <https://www.kpbs.org/news/2021/apr/20/mayor-gloria-expands-access-4-all-program-provide-/>; <https://www.craigslist.com/education/23-million-public-private-fund-get-tablets-internet-access-detroit-students>; <https://statetechmagazine.com/article/2021/03/how-4-cities-are-trying-close-digital-divide>

Backup | Detailed actions of each first-year key activity

Key Enablers

- 1 Obtain endorsement for the digital inclusion plan from key stakeholders**
 - Align on strategy with funders / advisors
 - Socialize plan and obtain buy-in from city county and commissioner court
 - Obtain support of mayor / county judge
- 2 Coordinate advocacy to secure required funding across sources**
 - Advocate for City / State funding
 - Maximize federal emergency dollars
 - Solicit private / philanthropic funds
- 3 Define the operating model and develop a resourcing plan**
 - Align on governance and accountability between public and private entities
 - Assign key roles on digital equity team
 - Determine plan for peak and steady state
- 4 Finalize key performance metrics to track progress and measure program success**
 - Refine the aspiration to inform KPIs
 - Define key performance metrics and identify mechanisms to measure them
 - Find hub to centralize data and analyses

Initiative Activation

- 5 Finalize strategy for public investment (e.g., open access, public rebate)**
 - Align on potential public investments
 - Vote on public projects to implement
 - Launch approved investment projects
- 6 Codify detailed fiber and asset maps to inform infrastructure deployment strategy**
 - Leverage existing city fiber, hard, and soft asset maps as a starting point
 - Engage third parties like Connected Nation, BroadbandNow, to verify data
 - Update maps to inform infra. strategy
- 7 Pursue the durable structure of a utility to carry broadband accessibility forward**
 - Decide if utility model should be pursued
 - Engage ISPs to discuss implications for the future around costs and regulations
 - Stand up durable broadband utility
- 8 Lineup execution teams and build-out detailed workplans**
 - Assign teams to execute each initiative
 - Detail workplans with owners, timelines, milestones, and associated costs
 - Launch initiatives, helping to alleviate pain points and support scaling

Stakeholder Engagement

- 9 Align on ISP engagement approach and begin conversations to build the collaboration and partnership model**
 - Determine strategy to partner with ISPs and identify key points of contact
 - Build rapport with ISPs through shared initiatives (e.g., adoption support, RFPs)
 - Push for deeper collaboration to make ISPs part of the digital equity solution
- 10 Create mechanism for ongoing community engagement, coordination, and activation**
 - Partner with community orgs for ad hoc efforts (e.g., awareness campaigns)
 - Establish touchpoints for ongoing engagement (e.g., meetings, town halls)
 - Setup centralized digital resources, like a community portal, to support households

Table of contents

3	Fact-base
4	Summary
6	Interviews and Community Engagement
19	Inventory Survey
28	K-12 Questionnaire
33	Size and Nature of the Digital Divide
47	ISP Economics & Engagement
56	Initiative Details
57	Infrastructure
93	Affordable Housing Access
104	Education Sponsored
127	Low-income Internet
149	Device Support
162	Adoption Support
191	Data & Analytics
214	Operating Model
244	Population Segments
250	Implementation Roadmap
273	Funding Databases
290	Asset Maps
291	Access Maps
294	Coverage Maps
300	Community Level Maps

COSA / Bexar can make use of available funding at federal, state & local levels



Federal



State



Local

Overview

The federal government unlocked **recovery funds** to connect households in COVID and continued **existing programs** to expand broadband access

Various **statewide initiatives** have been launched in Texas to increase digital equity

Local **city, county, and philanthropic funds** support community-based initiatives and municipal projects

Funds Available

- Recovery funds (e.g., CARES, CRRSA including EBB, ARPA)
- Existing programs (E-Rate, Lifeline)

- Operation Connectivity (education-focused)
- State budgets (e.g., new broadband legislation)

- City / County budgets
- Municipal broadband bonds

COSA / Bexar Actions

- Capture **available recovery dollars** where applicable
- Help orgs and households **apply for ongoing programs** while advocating for increased funds

- Leverage the **funds and negotiated pricing** unlocked by Operation Connectivity
- Ensure **adequate funding is passed** in new state legislation

- Identify the **best strategies** (e.g., municipal bonds, emerging tech) to connect communities
- **Fund community / city projects** where support is needed most

For each relevant major funding source, several key questions to consider

- Which specific funding streams intersect can be applied to broadband?
- Who is responsible for the funds and how are they allocated?
- How much funding is available to our focus geographies (e.g., state, county, city)?
- What are the allowable uses of funds?
- What plans are already in place for use of the funds? Where is there an opportunity to influence future plans?

Federal | Several buckets of recovery funds can be used for broadband access

Non-exhaustive

Coronavirus Aid, Relief, and Economic Security (CARES) Act

- COVID Relief Funding allocations to states for flexible use, including broadband
- Education Stabilization Fund allocations for distance learning
- USDA and FCC broadband programs to expand access

Coronavirus Response and Relief Supplemental Appropriations (CRRSA)

- Emergency Broadband Benefit (EBB) Fund to connect low-income households to internet
- Assistance for new or existing USDA, NTIA and FCC broadband programs
- Rental Assistance administered by state agencies (including broadband services)

The American Rescue Plan Act (ARPA)

- Coronavirus State and Local Fiscal Recovery Funds for flexible use, including broadband
- Coronavirus Capital Project Fund for infrastructure projects, with emphasis on connectivity
- Others including school/library connectivity funding through E-Rate, inclusion of broadband as an eligible use of the Homeowner Assistance fund, expansion of the Rental Assistance fund

American Jobs Plan (not yet enacted)¹

- Infrastructure focused transformation creating jobs and raising wages, with significant funding proposed for Broadband
- Infrastructure investments across transportation, water, electricity, and broadband services
- Goal of 100 percent high-speed broadband infrastructure coverage to un/underserved areas

Strategies must be developed to isolate Federal funds and maximize capture of the Bexar County broadband share

1. American Jobs Plan conference bill estimated for August at earliest

Federal | Potentially \$500M of recovery funding available for Bexar broadband



Broadband

\$50-100M

For COSA/Bexar broadband

	Bexar Broadband (\$M)
• Emergency Broadband Benefit	25-50
• E-rate funding	25-50

Partner with CBOs to drive EBB program awareness and adoption and support ISDs to implement E-rate



Other use cases

100-250M

For COSA/Bexar broadband

	Bexar (\$M)	Est. Broadband Allocation (\$M)
• Education (e.g., ESSER, GEER)	1,300	75-200
• Health (e.g., FCC telehealth)	250	25-50
• Housing (e.g., Rental Assistance)	220	<5

Engage relevant stakeholders (e.g., LEAs, CBOS) to prioritize digital use cases, raise awareness for programs



State and Local Gov't Fiscal Recovery

\$100-200M

For COSA/Bexar broadband

	Bexar (\$M)	Est. Broadband Allocation (\$M)
• State fiscal recovery fund	1,200	50-150
• County fiscal recovery fund	400	25-50
• City fiscal recovery fund	330	25-50
• State capital projects fund	30	<10

Advocate for State funding to be allocated to digital divide needs; partner with County and City officials on local processes secure funding for broadband

The funding for broadband is not guaranteed; the amount funding captured by Bexar County will vary depending on the initiative taken and priorities of those in charge

Federal | Existing federal funding can support broadband on an ongoing basis

Illustrative

Federal funding database ...

Details the owning agency, eligible expenses/recipients, and FY20 funding across programs

Emergency federal funding that can support broadband efforts (I/III)

Source	Size (\$)	Description	Distribution channel	SA Action Steps	Relevance for SA
Community health Initiatives	22B	Covers community health centers, public health workers, and other public health	Disbursements to health care providers based on formulas tracking patient intake.	Work with providers to support telehealth initiatives	

Emergency federal funding that can support broadband efforts (II/III)

Source	Total size	SA broadband share	Description	Distribution channel	SA Action Steps
Coronavirus State Fiscal Recovery			Provides flexible funds to be used	Funds directly sent to	Partner with governor's office and

Emergency federal funding that can support broadband efforts (III/III)

Source	Total size	SA broadband share	Description	Distribution channel	SA Action Steps
Tribal Broadband Connectivity Grant	\$1B	~\$5M	Supports infrastructure deployment (adoption) affordability on tribal lands	Tribal governments and organizations apply to receive grants	Apply through NTIA to access grant
Broadband Infrastructure Deployment Grant	\$2.8B	~\$5M	Advances deployment of fixed broadband service in qualifying areas	Projects under partnerships between state governments and either a local government or ISP within the state are eligible to apply	Apply through NTIA to access grant
Connecting Minority Communities Pilot Program	\$285M	~\$5M	Provides grants to minority institutions to support broadband development/adoption	HBCUs, Tribal colleges/universities, or other minority institutions are eligible	Apply through NTIA to access grant
Community health Initiatives	\$22B	\$6-25M	Covers community health centers, public health workers, and other public health investments	Disbursements to providers based on formulas tracking patient intake, operating expenses, and other criteria	Coordinate with providers to identify any unmet need and gaps in access
VA funding expansion ¹	\$16.7B	\$6-25M	Supports COVID-19 related health care, information technology, facility requirements, and telehealth	Funds spent within the VA supporting internal initiatives	Contact local VA to coordinate digital inclusion efforts
FCC telehealth Initiatives	\$200M	~\$5M	Supports health care professionals in providing information services and devices for telehealth services	Health care providers receive reimbursements for related expenses	Coordinate with providers to identify any unmet need and gaps in access
HHS Public Health and Social Services Emergency Fund	\$1.80M	~\$5M	Increase funds to DHPG to expand services and capacity for rural hospitals, including telehealth	Disbursements to health care providers calculated as a proportion of previous Medicare payments	Coordinate with providers to identify any unmet need and gaps in access
Emergency Rental Assistance	\$22B	~\$5M	Assists households that unable to pay rent/utilities due to COVID-19	State housing agencies receive funds to be disbursed to residents	Work with community orgs to spread awareness
Emergency Homeowner Assistance	\$10B	~\$5M	Assists households that unable to pay mortgage/utilities due to COVID-19	State housing agencies receive funds to be disbursed to residents	Work with community orgs to spread awareness

¹ Combined total of VA telecommunications funding (2.7B, CARES Act) and overall VA funding expansion (\$14.5B, ARF)
Source: American Rescue Plan (2021); National Law Review; National Association of Counties

... can be used to match COSA/Bexar initiatives to available grants



NTIA Broadband Infrastructure Deployment Grant to build fiber and expand access



Workforce Innovation and Opportunity Act (WIOA) to fund employment programs, including digital literacy trainings



Community Development Block Grant (CDBG) to support digital programs in affordable housing



Student Support and Academic Enrichment Program to improve use of technology/digital literacy programming for students

Full database included in appendix

Assess full list of COSA/Bexar broadband initiatives And available grants to determine which to act on

State | Texas to potentially unlock additional broadband funding through federal sources and the state budget via House Bill 5

Preliminary

Proposed elements of the House's Bill 5 Budget for 2022-2023



~\$3-4M of the state budget to go towards **administrative broadband funding** (e.g., creation of a Statewide Broadband Development Office)



Allocation of **\$100M of federal funding** towards broadband development programs



Expansion of digital programming in colleges (e.g., ~\$1M for UT Austin College of Fine Arts, ~\$1.8M for UT Permian Basin) and digital inclusion for libraries (e.g., ~\$3.75M in funding)



Provision of funding for **additional broadband projects** (e.g., ~\$550K for Monahans Broadband Project, ~\$250K for Cameron County broadband expansion)

*Advocate for state funds to be allocated to COSA / Bexar priority areas;
Identify areas where the state can play a state-wide role (vs. rural focus)*

State | TEA is coordinating state funding for student access

Since March 2020, Operation Connectivity, directed by Governor Greg Abbott, TEA, and Dallas ISD, has worked to close the K-12 digital divide

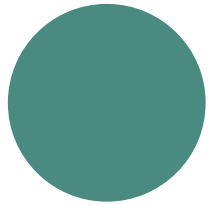

Phase 1: Historical triage using CARES funding

- Identified **\$600M+** in funding across Tech & Instructional Materials Allotment, and COVID relief funds (CARES Act)
- Developed a procurement strategy and negotiated with ISPs to secure a **20-40% discount**, closing the full device gap and ~35% of the internet gap

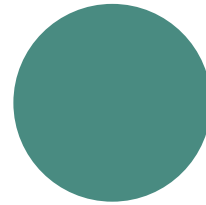

Phase II: Expansion of affordable access through contracting

- **Negotiating with ISPs** to get uniform low pricing on broadband service for students and families
- **Partnering with districts** to deliver hotspots to disconnected students to provide at-home broadband

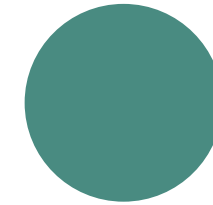

Phase III: Piloting and funding of emerging tech

- Launched RFO for traditional and **innovative technologies**, including radio wave and private LTE networks, to expand infrastructure for the 350K students without a broadband hook-up
- Considering allocating a portion of **\$12B of March 2021 ARP funding** to cover connectivity efforts

Stay up to date on program developments; use the affordable rates that are negotiated, and advocate for the education needs of COSA/Bexar ISDs

Local | Municipal bonds can be a mechanism to expand broadband access



Call to action for bond usage

Municipal bonds have historically been used to finance public projects (e.g., roads, schools)

Advocacy has grown around bond usage for digital inclusion:



TechBloc CEO, David Heard, pushed for inclusion of digital infrastructure in San Antonio's 2022 bond program



Forbes and Pew Trusts have advocated for the potential of municipal fiber bonds



Benefit of muni broadband bonds

Enables city-sponsored digital infrastructure buildout, akin to roadways, power, water projects

Creates public-private partnership between the city and ISP where residents are able to affordably repay the investment over time

Lowers prices and improves services through ISP competition, incentivizing strong performance for contracts renewals



Examples of municipal bonds



Salt Lake City communities combined to finance a **fiber network to homes**, allowing **all service providers** to operate to lower service costs



New Hampshire towns have issued bonds to **construct fiber networks**, funding the bond payments through **~\$10 monthly subscriber fees**

Consider municipal bond model and take necessary local steps to include proposal for City council

COSA / Bexar should focus on capturing available funding in the near-term and then advocate and unlock sustainable funding sources



Near-Term

Capture available funding, engaging schools, libraries, and community organizations to maximize spending and adoption of emergency federal / state funds

Key Actions

- Advocate at state level and partner on processes at the county and city levels to have for **federal recovery funds allocated to broadband uses**
- **Partner with community orgs to drive adoption** of broadband affordability programs (e.g., EBB, Lifeline, Rental Assistance)
- **Attract catalytic philanthropic donors** to fill gaps



Longer-Term









Advocate and unlock sustainable funding sources (e.g., government, private) to maintain and expand upon existing digital inclusion programming and infrastructure

Key Actions

- Advocate for **expanded sustainable federal funding** (e.g., E-Rate, digital literacy, improved Lifeline) and continue to apply for existing federal grants
- Partner with the state to allocate **sufficient funding and resources** in Texas' broadband plan
- Consider **new local strategies** (e.g., municipal bonds, public rebate) to connect communities

It is critical to identify who will drive these actions forward and how it will be coordinated

Emergency federal funding that can support broadband efforts (I/III)

	Source	Size (\$)	Description	Distribution channel	SA Action Steps	Relevance for SA
Health	Community health initiatives	22B	Covers community health centers, public health workers, and other public health investments	Disbursements to health care providers based on formulas tracking patient intake, operating expenses, and other criteria	Work with providers to support telehealth initiatives	
	VA funding expansion ¹	16.7B	Supports COVID-19 related health care, information technology, facility requirements, and telehealth	Funds spent within the VA supporting internal initiatives	Work with VA to support digital initiatives; raise awareness with vets	
	FCC telehealth initiatives	200M	Supports health care professionals in providing information services and devices for telehealth services	Health care providers receive reimbursements for related expenses	Work with providers to support telehealth initiatives	
	HHS Public Health and Social Services Emergency Fund	180M	Increase funds to DHHS to expand services and capacity for rural hospitals, including telehealth	Disbursements to health care providers calculated as a proportion of previous Medicare payments	Work with providers to support telehealth; but limited Bexar eligibility	
Housing	Emergency Rental Assistance	22B	Assists households that unable to pay rent/utilities due to COVID-19	State housing agencies receive funds to be disbursed to residents	Raise resident awareness and help them apply	
	Homeowner Assistance	10B	Assists households that unable to pay mortgage/utilities due to COVID-19	State housing agencies receive funds to be disbursed to residents	Raise resident awareness and help them apply	
Recovery Aid	Coronavirus State Fiscal Recovery Fund	220B	Provides broadband funds for underserved/underserved areas (i.e., without wireline access at 25/3 Mbps)	Funds directly sent to state government	Advocate for state government to prioritize digital divide efforts	
	Coronavirus Local Fiscal Recovery Fund	130B	Provides broadband funds for underserved/underserved areas (i.e., without wireline access at 25/3 Mbps)	Funds directly sent to local governments	Advocate for state government to prioritize digital divide efforts	
	Coronavirus Capital Projects Fund	10B	Provides funds for high-quality broadband, connectivity infrastructure, devices, and equipment	State governments may apply for grants from the Treasury Department	Advocate for state government to prioritize digital divide efforts	

 See next page for TX details

1. Combined total of VA telecommunications funding (2.2B, CARES Act) and overall VA funding expansion (\$14.5B, ARP)
Source: American Rescue Plan (2021); National Law Review; National Association of Counties

SA/Bexar County to receive **\$700M+** in Recovery Aid, Texas another \$17B that can be used for broadband efforts

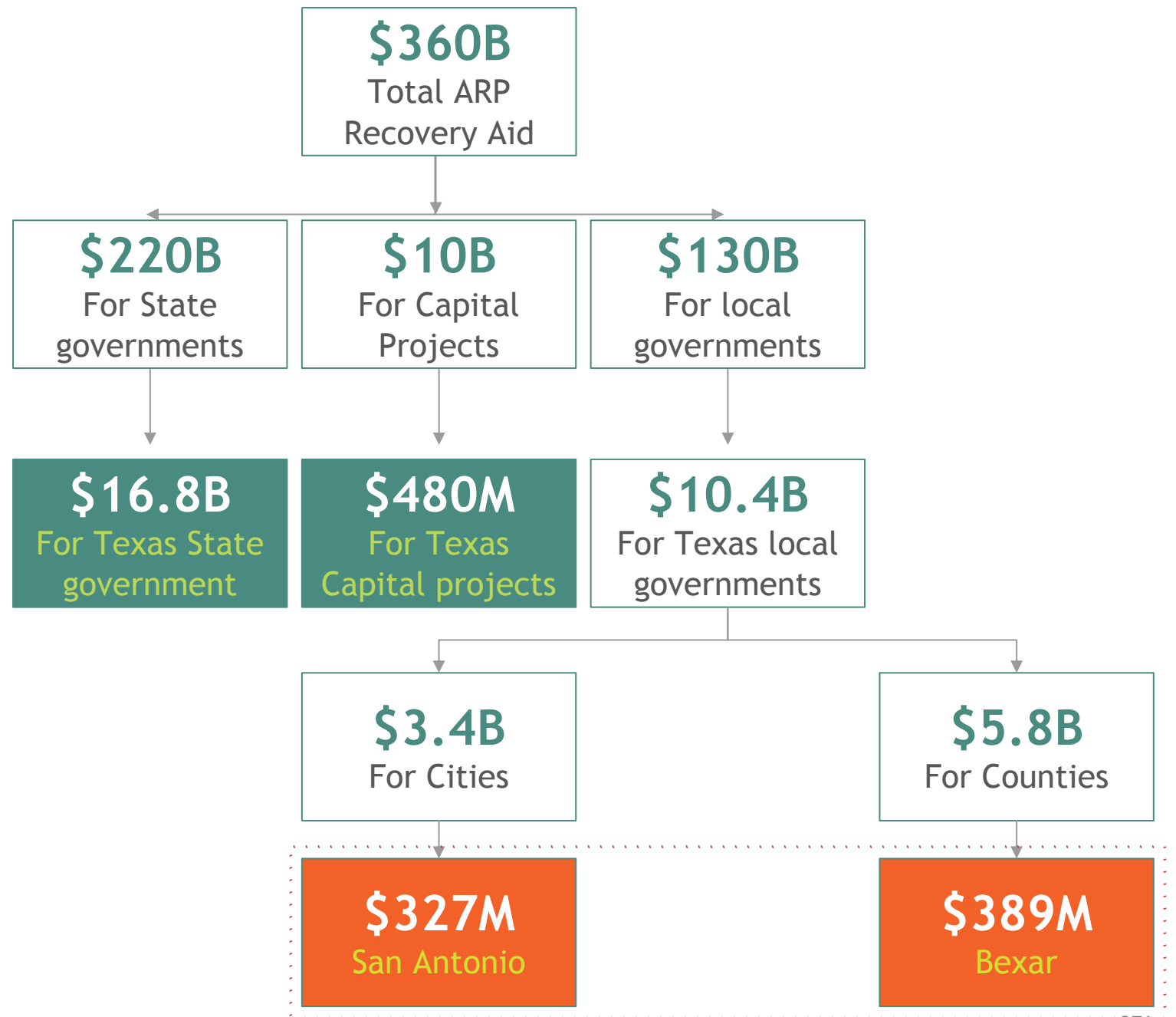

Emergency federal funding that can support broadband efforts (II/III)

	Source	Total size	SA broadband share	Description	Distribution channel	SA Action Steps
Recovery Aid	Coronavirus State Fiscal Recovery Fund	\$220B	\$100M+	Provides flexible funds to be used for a variety of purposes relating to COVID-19 fiscal recovery	Funds directly sent to state government	Partner with governor's office and state legislature to allocate additional funding for digital agenda
	Coronavirus Local Fiscal Recovery Fund	\$130B	\$50-100M	Provides flexible funds to be used for a variety of purposes relating to COVID-19 fiscal recovery	Funds directly sent to local governments	Work with local stakeholders to identify unmet needs determine most effective fund allocation
	Coronavirus Capital Projects Fund	\$10B	<\$5M	Provides flexible funds to be used in the areas of work, education, and health monitoring	State governments may apply for grants from the Treasury Department	Partner with governor's office and state legislature to allocate additional funding for digital agenda
Education	ESSER ¹	\$190B	\$100M+	Provides flexible relief funds for K-12 students impacted by the pandemic	LEAs must apply to SEAs in order to access subgrants. Allocation based on Title I formula	Apply through TEA to access grants for ISDs
	GEER ²	\$4.3B	<\$5M	Provides flexible relief funds for K-12 students impacted by the pandemic	Governors may provide subgrants LEAs after submitting grant request to Department of Education	Partner with governor's office to provide subgrants to ISDs
Broadband	Emergency (E-rate) Connectivity Fund	\$7.1B	\$25-50M	Funds connectivity and devices for in-home use	Eligible schools and libraries can solicit competitive bids and select providers	Negotiate with ISPs on behalf of ISDs to reach most favorable terms for service
	Emergency Broadband Benefit (FCC)	\$3.2B	\$25-50M	Provides subsidy to low-income households for broadband in form of monthly discount	Households apply through providers; providers will submit for reimbursement	Work with community groups to spread awareness and encourage mass program participation
	Economic Adjustment Assistance (EAA) Program	\$3B	<\$5M	Subsidizes broadband projects in economically distressed communities	Municipal and local governments are eligible to apply for grants	Contact regional office for Economic Development Administration (EDA) to submit grant application

1. Combined total of ESSER I (\$13.2B, CARES Act), ESSER II (\$54.3B, CRRSA), and ARP ESSER 2. Combined total of GEER I (\$1B, CARES Act) and GEER II (CRRSA)
 Source: American Rescue Plan (2021); National Law Review; National Association of Counties

Emergency federal funding that can support broadband efforts (III/III)

	Source	Total size	SA broadband share	Description	Distribution channel	SA Action Steps
Broadband	Tribal Broadband Connectivity Grant	\$1B	<\$5M	Supports infrastructure deployment /adoption/affordability on tribal lands	Tribal governments and organizations apply to receive grants	Apply through NTIA to access grant
	Broadband Infrastructure Deployment Grant	\$288M	<\$5M	Advances deployment of fixed broadband service in qualifying areas	Projects under partnerships between state governments and either a local government or ISP within the state are eligible to apply	Apply through NTIA to access grant
	Connecting Minority Communities Pilot Program	\$285M	<\$5M	Provides grants to minority institutions to support broadband development/adoption	HBCUs, Tribal colleges/ universities, or other minority institutions are eligible	Apply through NTIA to access grant
Health	Community health initiatives	\$22B	\$5-25M	Covers community health centers, public health workers, and other public health investments	Disbursements to providers based on formulas tracking patient intake, operating expenses, and other criteria	Coordinate with providers to identify any unmet need and gaps in access
	VA funding expansion ¹	\$16.7B	\$5-25M	Supports COVID-19 related health care, information technology, facility requirements, and telehealth	Funds spent within the VA supporting internal initiatives	Contact local VA to coordinate digital inclusion efforts
	FCC telehealth initiatives	\$200M	<\$5M	Supports health care professionals in providing information services and devices for telehealth services	Health care providers receive reimbursements for related expenses	Coordinate with providers to identify any unmet need and gaps in access
	HHS Public Health and Social Services Emergency Fund	\$180M	<\$5M	Increase funds to DHHS to expand services and capacity for rural hospitals, including telehealth	Disbursements to health care providers calculated as a proportion of previous Medicare payments	Coordinate with providers to identify any unmet need and gaps in access
Housing	Emergency Rental Assistance	\$22B	<\$5M	Assists households that unable to pay rent/utilities due to COVID-19	State housing agencies receive funds to be disbursed to residents	Work with community orgs to spread awareness
	Homeowner Assistance	\$10B	<\$5M	Assists households that unable to pay mortgage/utilities due to COVID-19	State housing agencies receive funds to be disbursed to residents	Work with community orgs to spread awareness

1. Combined total of VA telecommunications funding (2.2B, CARES Act) and overall VA funding expansion (\$14.5B, ARP)
 Source: American Rescue Plan (2021); National Law Review; National Association of Counties

Ongoing Federal Funding (I/III)

Agency	Program	Description	Eligible Recipient	FY'20 Funding
FCC	High-cost Program (incl. Connect America, Rural Digital Opp., 5G Funds)	Broadband infra. for rural, high-cost areas at rates comparable to urban	Eligible telco carriers	\$4.5B
National Science Foundation	Platforms for Advanced Wireless Research	Experimental research and evaluation on next-gen wireless tech	Libraries, schools, ISPs, SMBs, hospitals, utilities	\$9M
National Science Foundation	Smart and Connected Communities	Research pairs tech/social advances with comm. engagement/econ. dev.	Same as above + state/local govt.	\$43M
National Science Foundation	Spectrum/Wireless Innovation enabled by Future Technologies	Research on effective wireless spectrum utilization	Higher education institutions	\$12M
U.S. Department of Transportation	BUILD (F/k/a TIGER)	Supports capital infrastructure projects incl. connecting communities/people to jobs, services, and education etc.	State/local govts., tribal entities	\$1B
> Federal Highway Administration	Realty Program (Utility Right-of-way) and Utilities Program	Funding for construction/maintenance of highways/public services	State / local govts., tribal entities	TBD
FEMA / DHS	State Homeland Security Program and Urban Areas Security Initiative	Cybersecurity, enhancing infrastructure resiliency incl. broadband deployment	State Administrative Agency deploys fund within the state/ UASIs	FY'21: \$505M to SHSP,; \$705M to UASI.
FEMA / DHS	Emergency Management Performance Grants	Purchase of comms. tech/devices for wireless broadband network buildout	FEMA awards funds directly to all states/territories	FY'21: \$355M
U.S. Department of Transportation	INFRA Grants	Funding highway/freight projects, incl. broadband deployment	TBD	\$906M
National Science Foundation	Campus Cyberinfrastructure (CC*)	Invests in cyberinfrastructure, innovation for science applications	Higher education institutions, non-profits	\$17M

Availability

Ongoing Federal Funding (II/III)

	Agency	Program	Description	Eligible Recipient	FY'20 Funding
Afford.	FCC	Lifeline	Discount on phone/broadband service for low-income HHs	Eligible telco carriers	FY'19: \$982M
	Employment and Training Admin.	Workforce Innovation and Opportunity Act (WIOA)	Workforce dev/employment programs, incl. digital literacy training	Higher education institution, state/local govts.	\$5.5B
Adoption	Employment and Training Admin.	Trade Adjustment Assistance Community College/Career Training Program	Worker trainings/programs in manufacturing, health care, IT, etc.	Community colleges	\$1.9B
	Employment and Training Admin.	Workforce Development in Telco. Sector	Apprenticeship programs for telco. careers to meet network infra. needs	Employers	\$6M
	Institute of Museum and Library Services	Grants to States Program	Support America's museums, libraries, and related organizations	Libraries, state/local govts.	\$166M
Econ. Dev.	Economic Development Administration	Disaster Supplemental Notice of Funding Opportunity	Develop/improve assets so that businesses can form, grow, innovate	Libraries, non-profit orgs, higher education, state/local govt., tribal entities	FY'19: \$587 Million
	Economic Development Administration	Public Works and Economic Adjustment Assistance Programs	Supports economic development e.g., job creation, investment, innovation	Libraries, non-profit orgs, higher education, state/local govt., tribal entities	FY'20: \$200M
	HUD Community Planning and Development Office	Section 108 Loan Guarantee	Federally guaranteed loans for physical and economic revitalization projects.	State/local govts., non-profit, rural recipients	\$300M

Ongoing Federal Funding (III/III)

	Agency	Program	Description	Eligible Recipient	FY'20 Funding
Econ. Dev.	Community Development Financial Institutions Fund	New Markets Tax Credit Program	Business investment in underserved low-income communities	Community Development Entities (CDEs)	\$5B
	Office of the Comptroller of the Currency (OCC)	Community Reinvestment Act (CRA)	Encourages financial institutions to help meet the credit needs of low-income comm.	TBD	TBD
Public Housing	HUD Community Planning and Development Office	Community Development Block Grant (CDBG)	Support for affordable housing and economic revitalization	State/local govts., non-profit, rural recipients	\$3.4B
	HUD Office of Multifamily Housing	Neighborhood Networks (multifamily housing)	Community tech. centers for digital opportunity to low-income residents of HUD	HUD Property Owners	\$4.5B
Education	Department of Education	Improving Basic Programs Operated by LEAs	Investment in academic achievement of low-income students	State/local govts., rural recipients	\$16B
	Department of Education	Student Support/Academic Enrichment Program	Improving the conditions for learning/digital literacy for all students.	K-12 schools, state/local govt.	\$1.2B
	Department of Education	Strengthening Institutions	Strengthen academic quality of higher ed. that supports low-income students	Higher education institutions	\$107M
	FCC	E-Rate Program	Schools/libraries receive discounts on costs of in-school internet	Libraries, K-12 schools	FY'19: \$4B
Health	Universal Service Administrative Company	Connected Care Pilot Program (and Emergency COVID-19 Telehealth Program)	A three-year pilots for support connected care and telehealth over the long term	Non-profits, health care provider	FY'21: \$250M

Table of contents

3	Fact-base
4	Summary
6	Interviews and Community Engagement
19	Inventory Survey
28	K-12 Questionnaire
33	Size and Nature of the Digital Divide
47	ISP Economics & Engagement
56	Initiative Details
57	Infrastructure
93	Affordable Housing Access
104	Education Sponsored
127	Low-income Internet
149	Device Support
162	Adoption Support
191	Data & Analytics
214	Operating Model
244	Population Segments
250	Implementation Roadmap
273	Funding Databases
290	Asset Maps
291	Access Maps
294	Coverage Maps
300	Community Level Maps

Table of contents

3	Fact-base
4	Summary
6	Interviews and Community Engagement
19	Inventory Survey
28	K-12 Questionnaire
33	Size and Nature of the Digital Divide
47	ISP Economics & Engagement
56	Initiative Details
57	Infrastructure
93	Affordable Housing Access
104	Education Sponsored
127	Low-income Internet
149	Device Support
162	Adoption Support
191	Data & Analytics
214	Operating Model
244	Population Segments
250	Implementation Roadmap
273	Funding Databases
290	Asset Maps
291	Access Maps
294	Coverage Maps
300	Community Level Maps

Recall | Broadband Access varies significantly across zip codes...

Percentage Without Broadband Connection Bexar County, TX

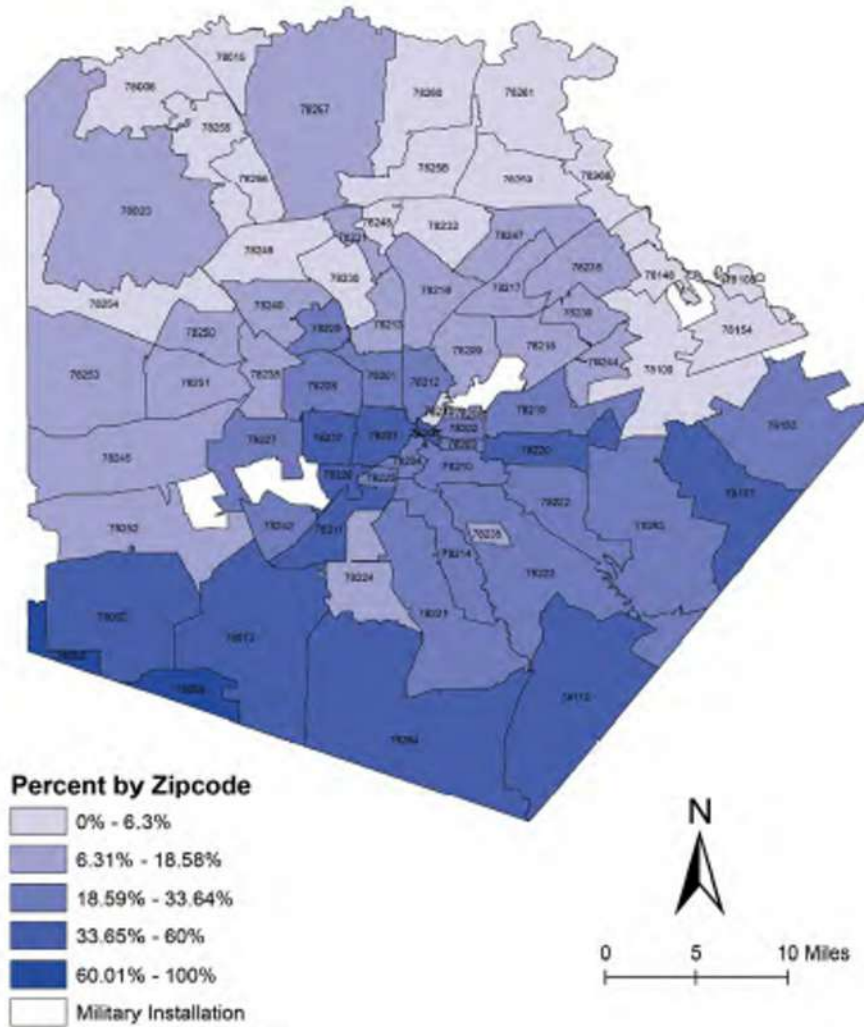

Figure 5: Percentage of Households without Broadband by Zip Code

Source: Digital Inclusion Survey and Assessment (2019)

The Southside and Westside of Bexar County are disproportionately lack access

Lack of Broadband Access by Zip (SASpeakUp)

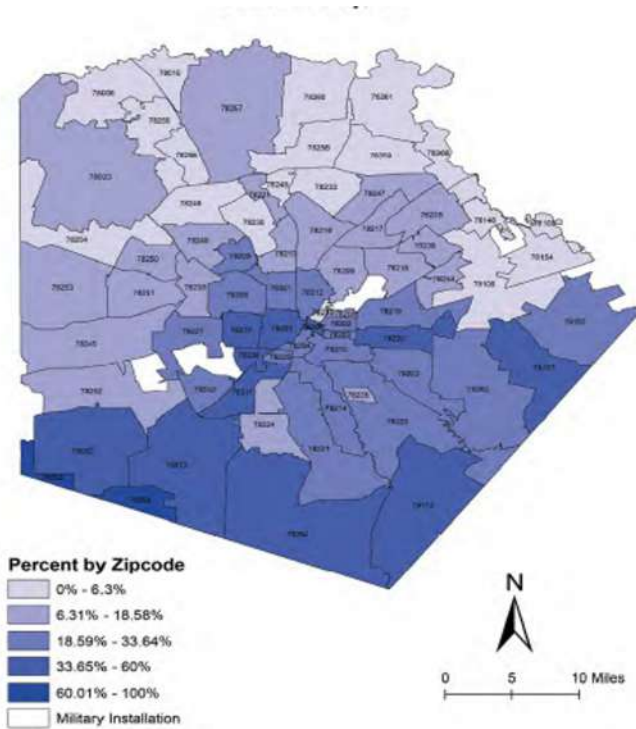

Figure 5: Percentage of Households without Broadband by Zip Code

Lack of Broadband Access by Census Tract (ACS)

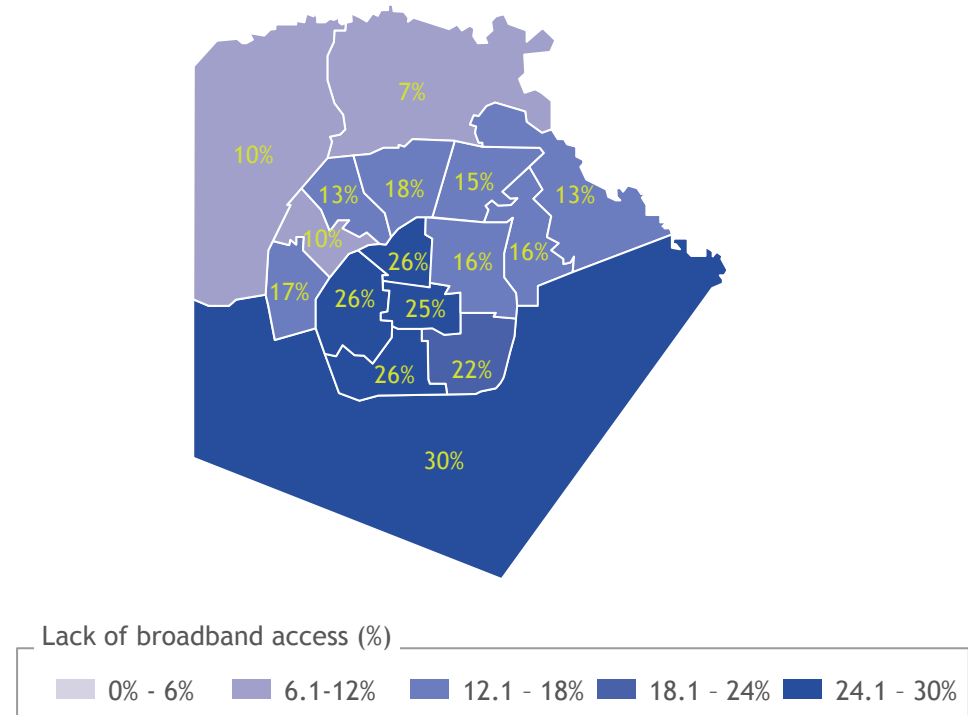
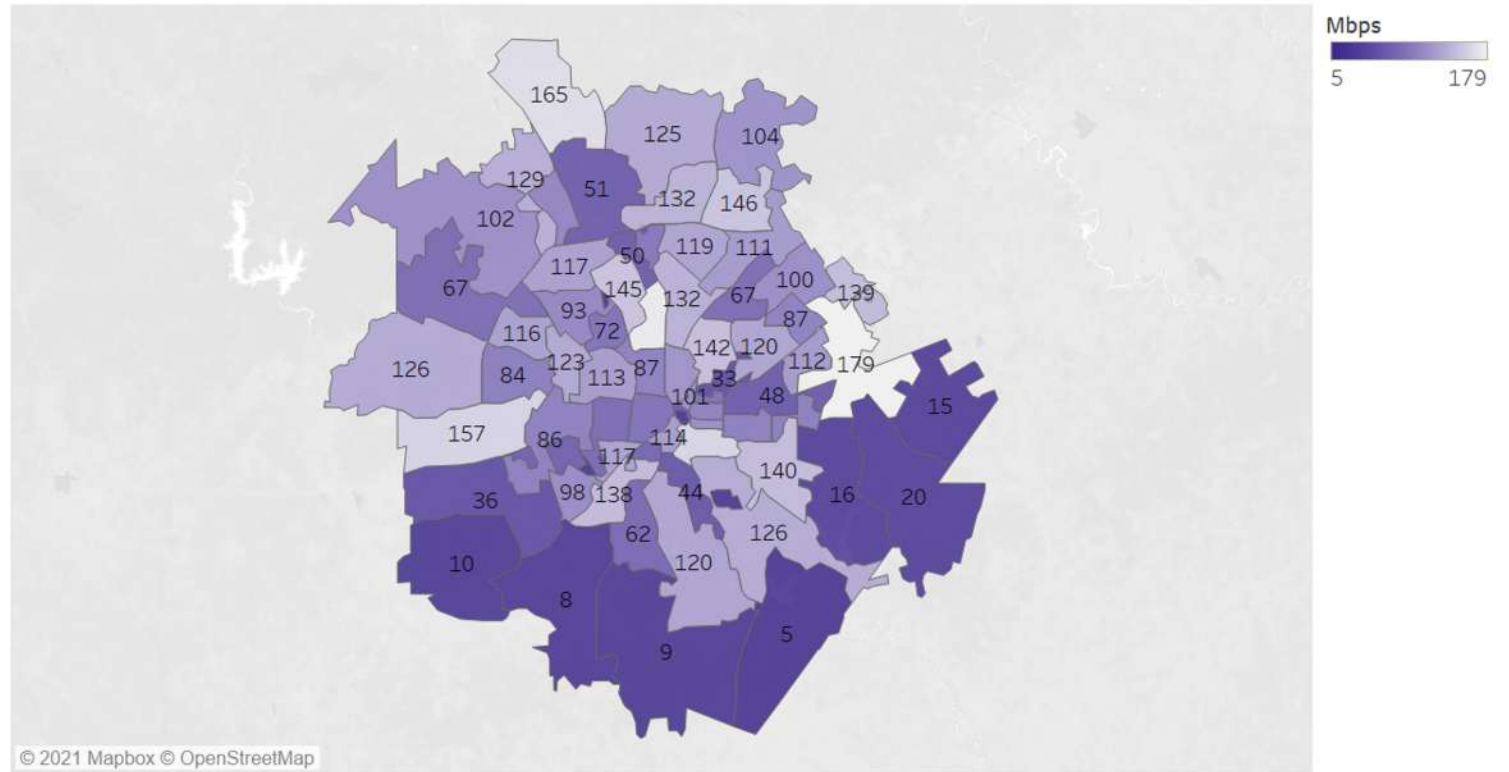

Table of contents

3	Fact-base
4	Summary
6	Interviews and Community Engagement
19	Inventory Survey
28	K-12 Questionnaire
33	Size and Nature of the Digital Divide
47	ISP Economics & Engagement
56	Initiative Details
57	Infrastructure
93	Affordable Housing Access
104	Education Sponsored
127	Low-income Internet
149	Device Support
162	Adoption Support
191	Data & Analytics
214	Operating Model
244	Population Segments
250	Implementation Roadmap
273	Funding Databases
290	Asset Maps
291	Access Maps
294	Coverage Maps
300	Community Level Maps

... and average connectivity speeds experienced by consumers

Average Download Speed, rolling 12 months



Map based on Longitude (generated) and Latitude (generated). Color shows sum of Average Mbps. Details are shown for Zip. The data is filtered on County, which keeps Bexar.

Despite high reported infrastructure coverage in national data sources, lived experience shows gaps in actual service coverage and quality

While BroadbandNow shows average 99% coverage 100+ Mbps across Bexar....

...lived experiences tell a different story

- “Some neighborhoods are still dealing with copper wire, meaning that if it rains they lose internet”
- “Lack of adequate housing compounds access problems. Some roofs are so short you can't even put a booster on the house. Others are covered by tree canopies that block signal from reaching the home”
- “There's no shared definition of what basic service even means, so ISPs can claim coverage, but the quality of service isn't there”
- “A provider can service one house in a zip code and call it covered, but that does not mean every house is served”

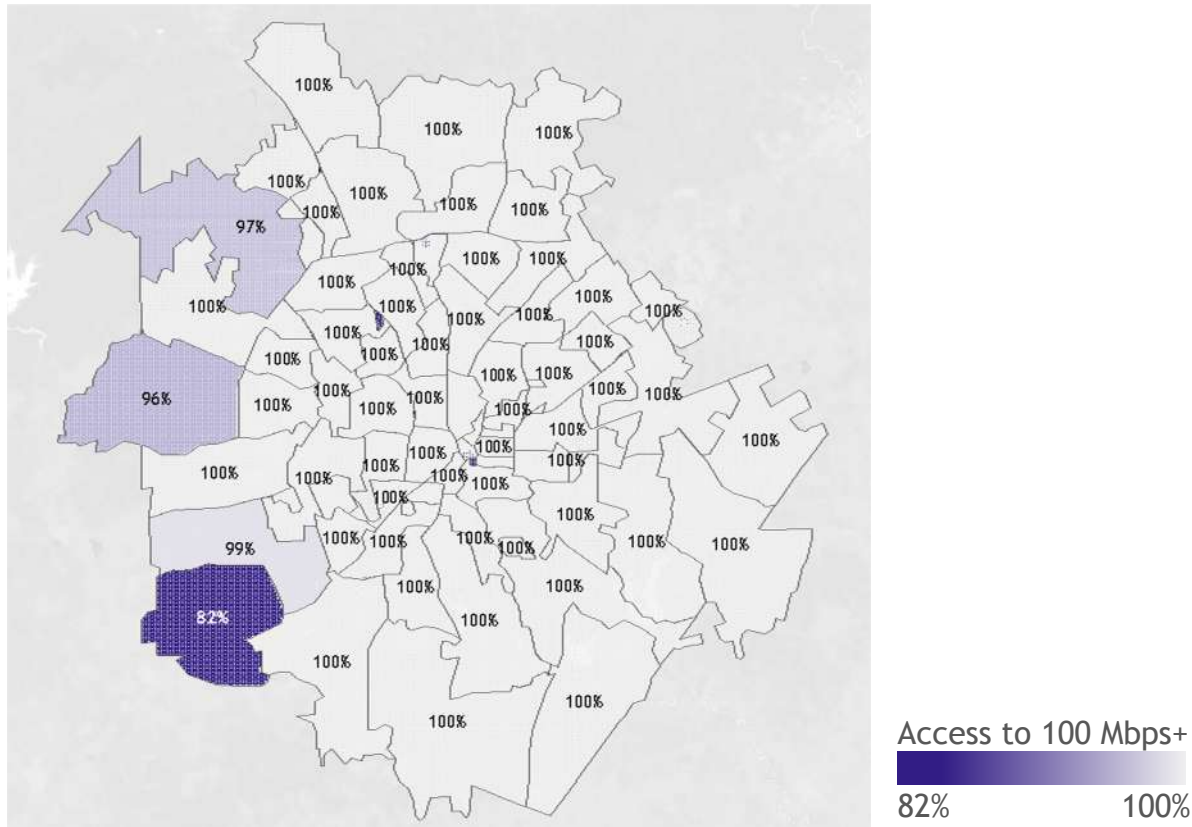

Some areas on the Southside are served by few providers

Number of providers offering speeds of 100+ Mbps

Number of ISPs present offering speeds of at least 100 Mbps Download / 3 Mbps Upload

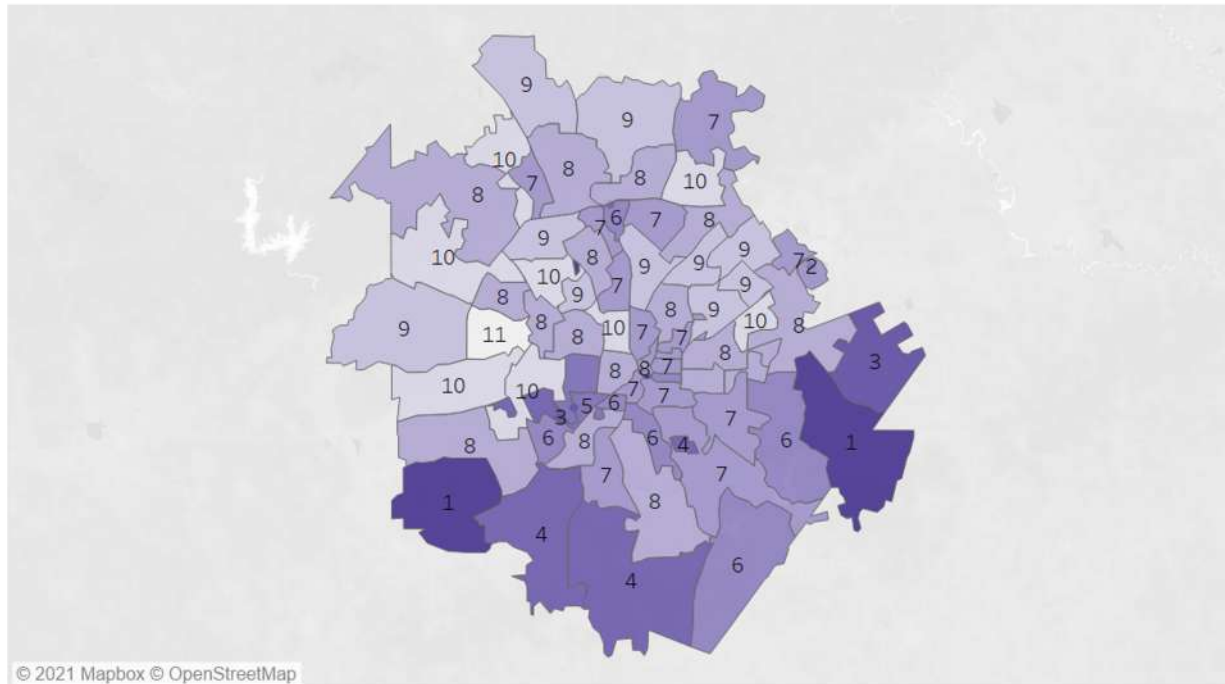

© 2021 Mapbox © OpenStreetMap

Map based on Longitude (generated) and Latitude (generated). Color shows sum of All100 3. Details are shown for Zip. The data is filtered on County, which keeps Bexar.

Implications for households

- In areas with only one provider, some houses may not be served at all
- Areas with limited provider choice often leads to challenges around affordability and cost of service

Layered approximation of fiber coverage and number of households without access to fiber

Approximation of extent of fiber by area

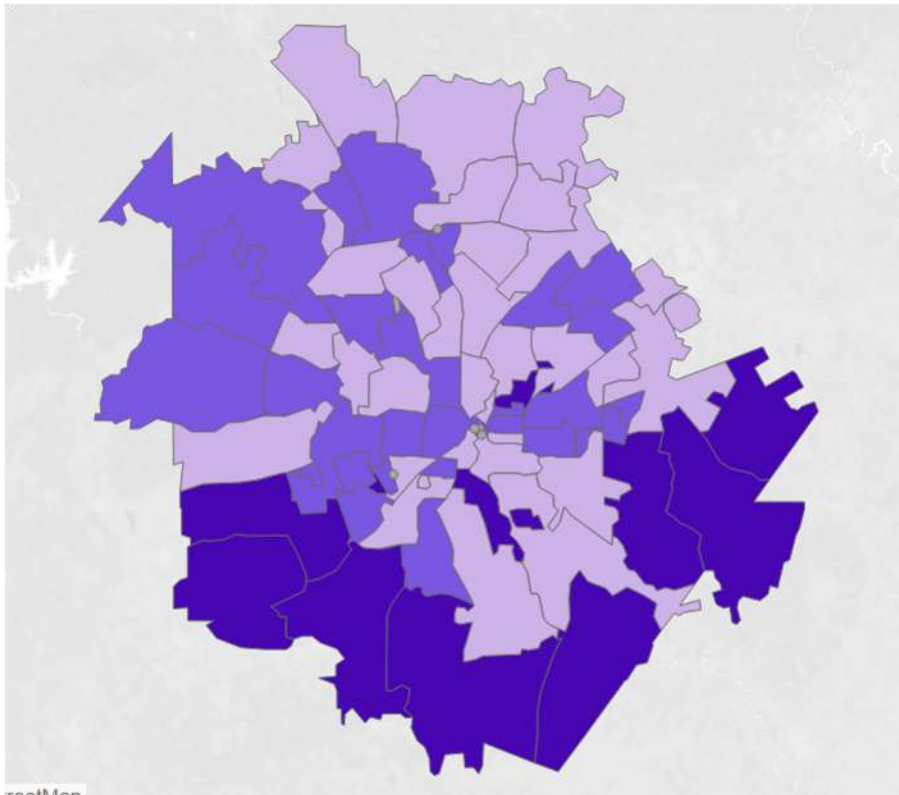

Approximation of the number of households without access to fiber

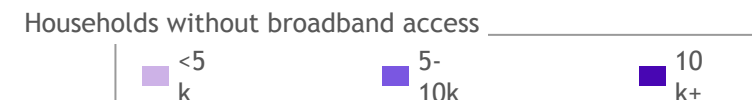
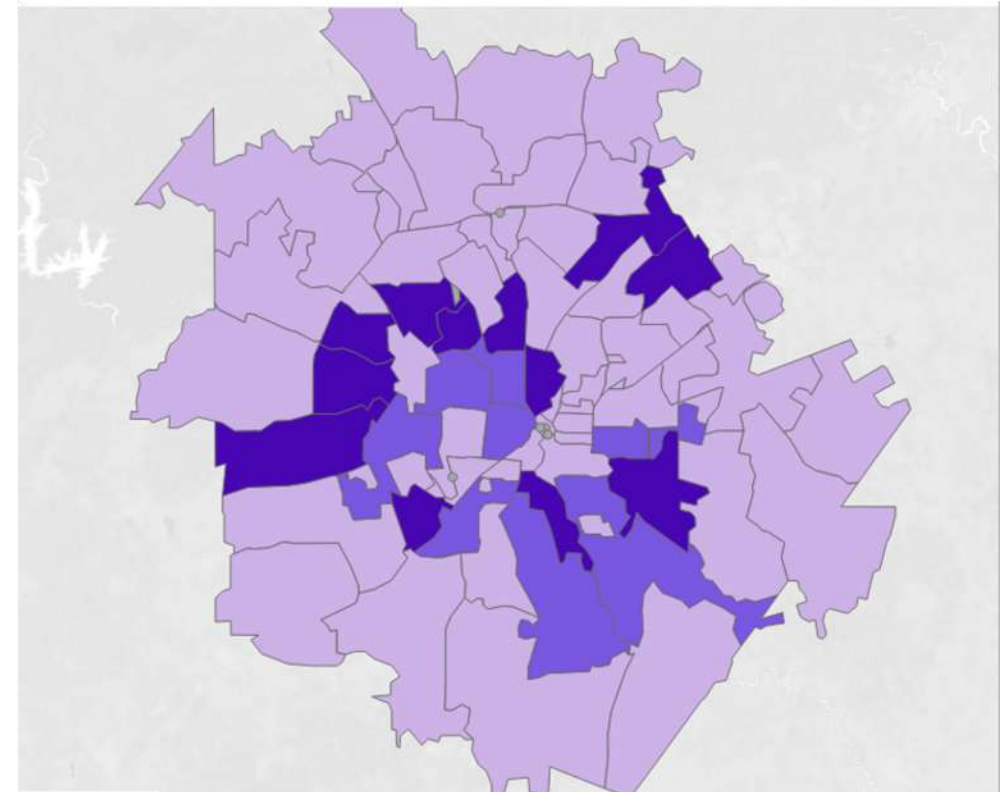

Mapping efforts can build on existing municipal and provider fiber maps

COSA maps

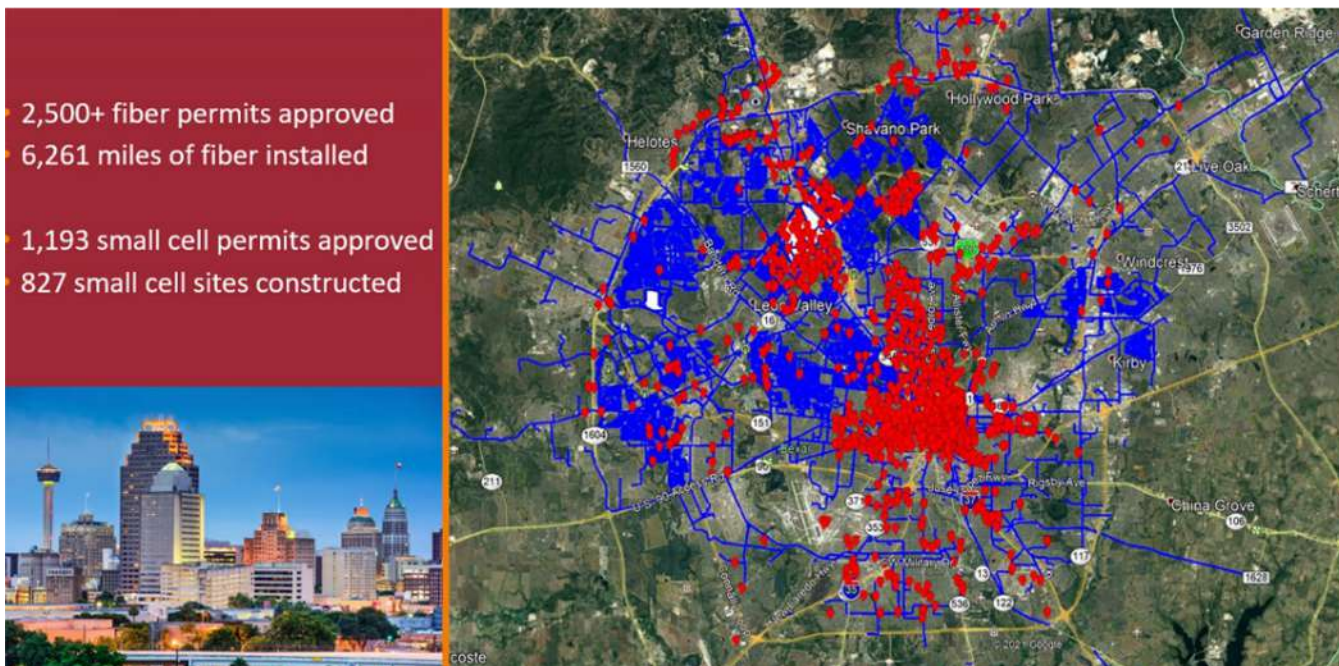

ISP maps

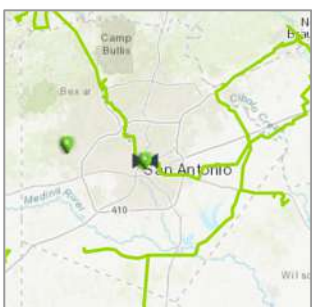

Fiber Light



Zayo Fiber



Crown Castle



Unite Private Networks

Source: COSA; Zayo; Crown Castle; Fiber Light; Unite Private Networks

Aggregating data

SA/Bexar city incorporate existing municipal proprietary maps with other sources to develop **comprehensive hard asset maps** that can be leveraged to inform targeted solutions and support the RFP and procurement process

Table of contents

3	Fact-base
4	Summary
6	Interviews and Community Engagement
19	Inventory Survey
28	K-12 Questionnaire
33	Size and Nature of the Digital Divide
47	ISP Economics & Engagement
56	Initiative Details
57	Infrastructure
93	Affordable Housing Access
104	Education Sponsored
127	Low-income Internet
149	Device Support
162	Adoption Support
191	Data & Analytics
214	Operating Model
244	Population Segments
250	Implementation Roadmap
273	Funding Databases
290	Asset Maps
291	Access Maps
294	Coverage Maps
300	Community Level Maps

Preliminary mapping offers insight into household need and points to next steps for future iterations



What this is



What this is not

	✓	✗
1 Without adequate digital <u>access</u>	Self-reported usage to reliable internet and devices (from SASpeakUp, ACS)	Verified adoption based on usage (e.g., from Microsoft, Google)
2 Facing <u>availability</u> barriers	Self-reported slow / unavailable service (from SASpeakUp) and recorded zip-level avg. speeds (from BroadbandNow)	Validated assessment of realized speeds (e.g., from speed tests) and household-level fiber / asset maps
3 Facing <u>affordability</u> barriers	Household self-reported inability to afford a monthly bill (from SASpeakUp)	Comparison of household income to cost of available services and price benchmarks

Preliminary

Access | Households without adequate digital access by Precinct

Households per precinct in 000s¹

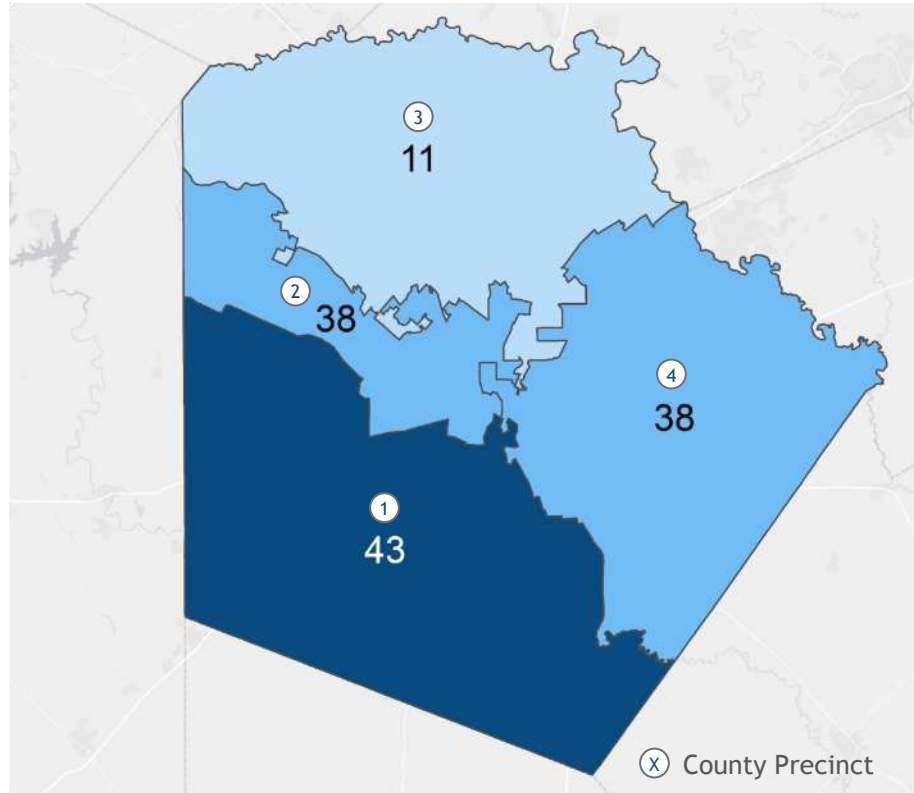

	Households without internet			
Precinct 1	43K	26%	21K	13%
Precinct 2	38K	23%	17K	10%
Precinct 3	11K	17%	7K	5%
Precinct 4	38K	23%	20K	12%
County Total (SA+Bexar)	130K	20%	65K	10%

1. Based on Census ACS and SASpeakUp responses of residents reporting that they lack access to the internet
Source: SASpeakUp (2019); US Census (2020); BCG analysis

Availability | Households with limited broadband availability by Precinct

Households per precinct in 000s¹

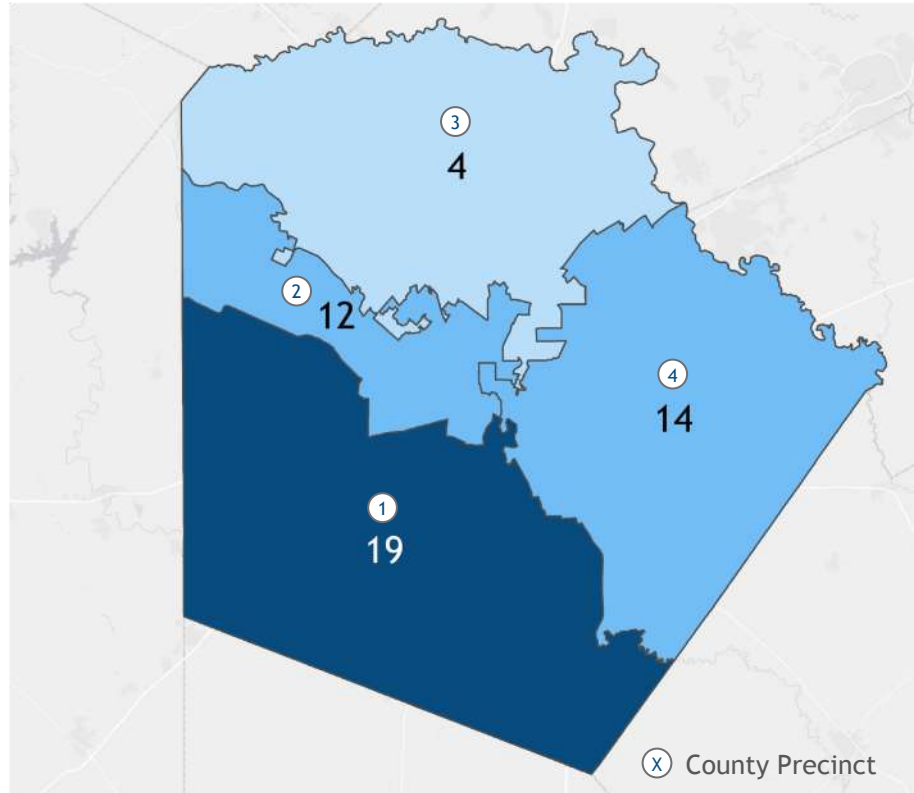

	Households with limited broadband availability		
Precinct 1	19K	43K	44%
Precinct 2	12K	38K	31%
Precinct 3	4K	16K	33%
Precinct 4	14K	38K	38%
County Total (SA+Bexar)	50K	130K	38%

1. Based on SASpeakUp responses reporting slow or unavailable service as residents' primary reason for not using the internet and BroadbandNow data on average speed per zip code
Source: SASpeakUp (2019); BroadbandNow; BCG analysis

Affordability | Households with limited broadband affordability by Precinct

Households per precinct in 000s¹

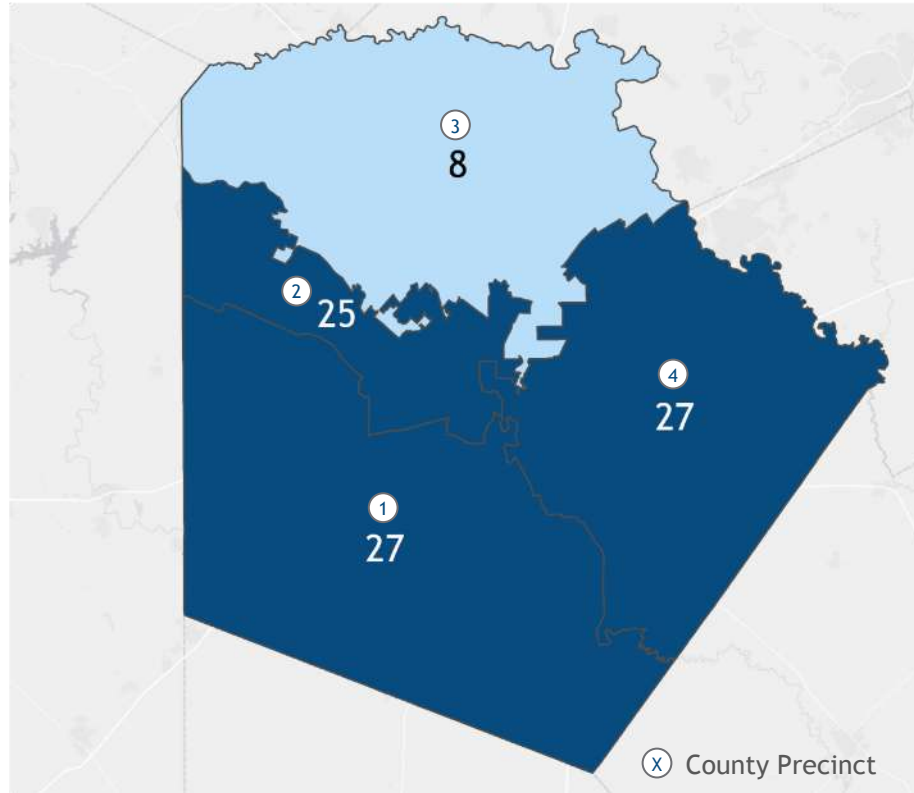

	Households without affordable internet		
Precinct 1	27K	43K	64%
Precinct 2	25K	38K	66%
Precinct 3	8K	16K	75%
Precinct 4	27K	38K	72%
County Total (SA+Bexar)	90K	130K	68%

1. Based on SASpeakUp responses of residents reporting that high internet plan pricing is their primary reason for not using the internet
Source: SASpeakUp (2019); BCG analysis

Preliminary

Access | Households without adequate digital access by District

Households per district in 000s¹

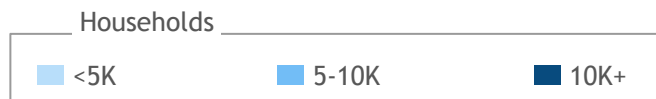
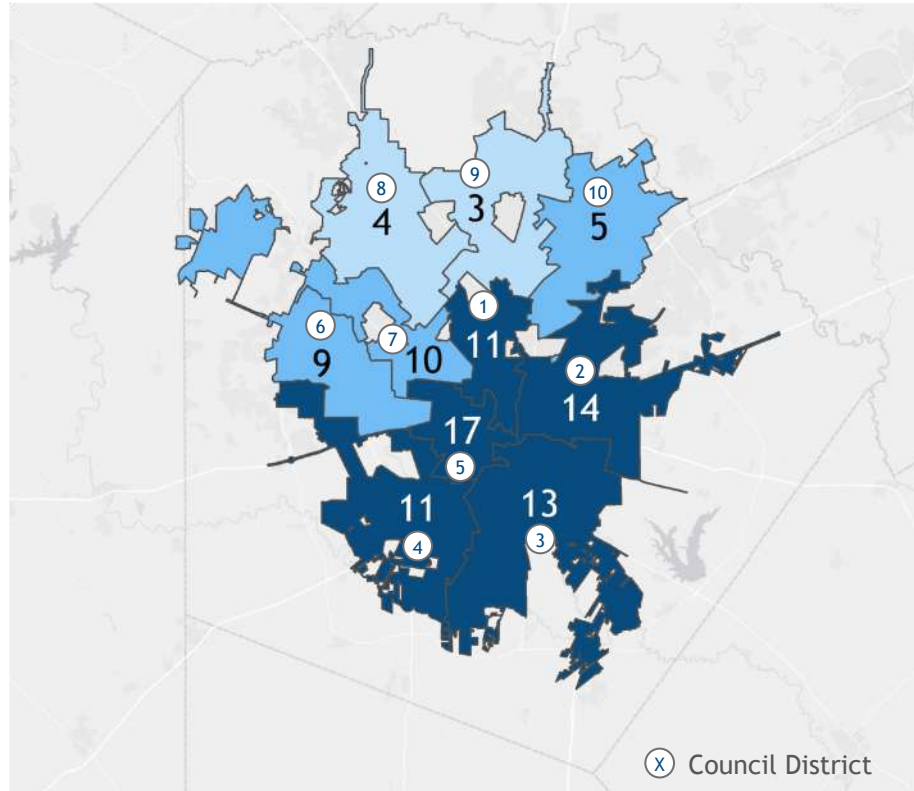

	Households without internet			
District 1	11K	25%	6K	14%
District 2	14K	27%	6K	12%
District 3	13K	25%	7K	14%
District 4	11K	23%	6K	12%
District 5	17K	38%	11K	23%
District 6	9K	17%	4K	7%
District 7	10K	18%	4K	7%
District 8	4K	7%	2K	4%
District 9	3K	6%	3K	6%
District 10	5K	9%	2K	6%
City total	100K	20%	53K	10%
County Total (SA+Bexar)	130K	20%	65K	10%

1. Based on Census ACS and SASpeakUp responses of residents reporting that they lack access to the internet
Source: SASpeakUp (2019); US Census (2020); BCG analysis

Availability | Households with limited broadband availability by District

Households per district in 000s¹

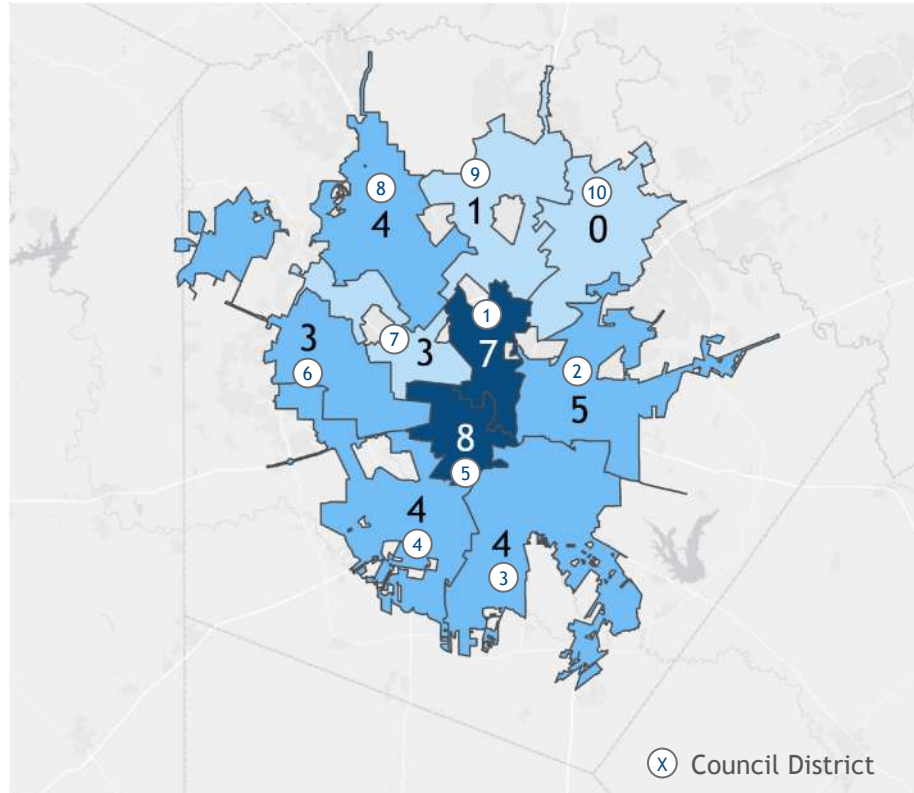

	Households with limited broadband availability		
District 1	7K	11K	64%
District 2	5K	14K	36%
District 3	4K	13K	32%
District 4	4K	11K	39%
District 5	8K	17k	44%
District 6	3K	9K	32%
District 7	3K	10K	29%
District 8	4K	4K	100%
District 9	1K	3K	50%
District 10	<1K	5K	<1%
City total	40K	100K	41%
County Total (SA+Bexar)	50K	130K	38%

1. Based on SASpeakUp responses reporting slow or unavailable service as residents' primary reason for not using the internet and BroadbandNow data on average speed per zip code
 Source: SASpeakUp (2019); BroadbandNow; BCG analysis

Affordability | Households with limited broadband affordability by District

Households per district in 000s¹

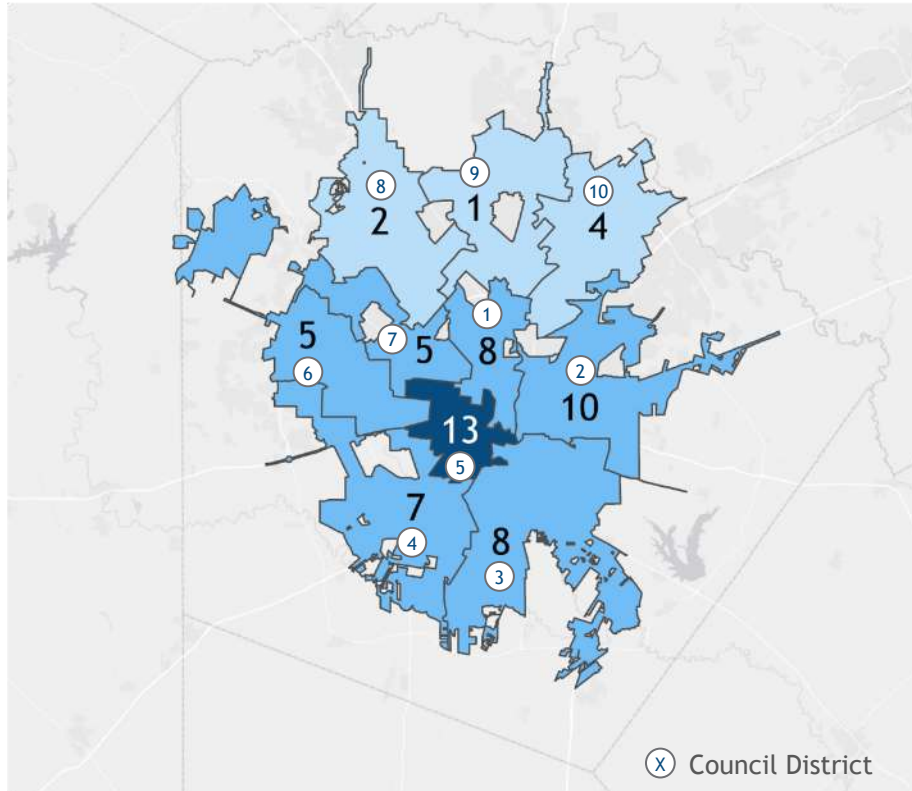

	Households without affordable internet		
District 1	8K	11K	75%
District 2	10K	14K	69%
District 3	8K	13K	65%
District 4	7K	11K	59%
District 5	12K	17k	73%
District 6	5K	9K	52%
District 7	5K	10K	53%
District 8	2K	4K	50%
District 9	1K	3K	50%
District 10	5K	5K	80%
City total	64K	100K	65%
County Total (SA+Bexar)	90K	130K	69%

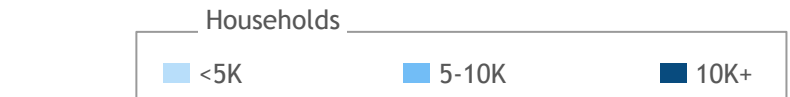

1. Based on SASpeakUp responses of residents reporting that high internet plan pricing is their primary reason for not using the internet
 Source: SASpeakUp (2019); BCG analysis

Preliminary

Access | Households without adequate digital access by Census block

Households per precinct in 000s¹

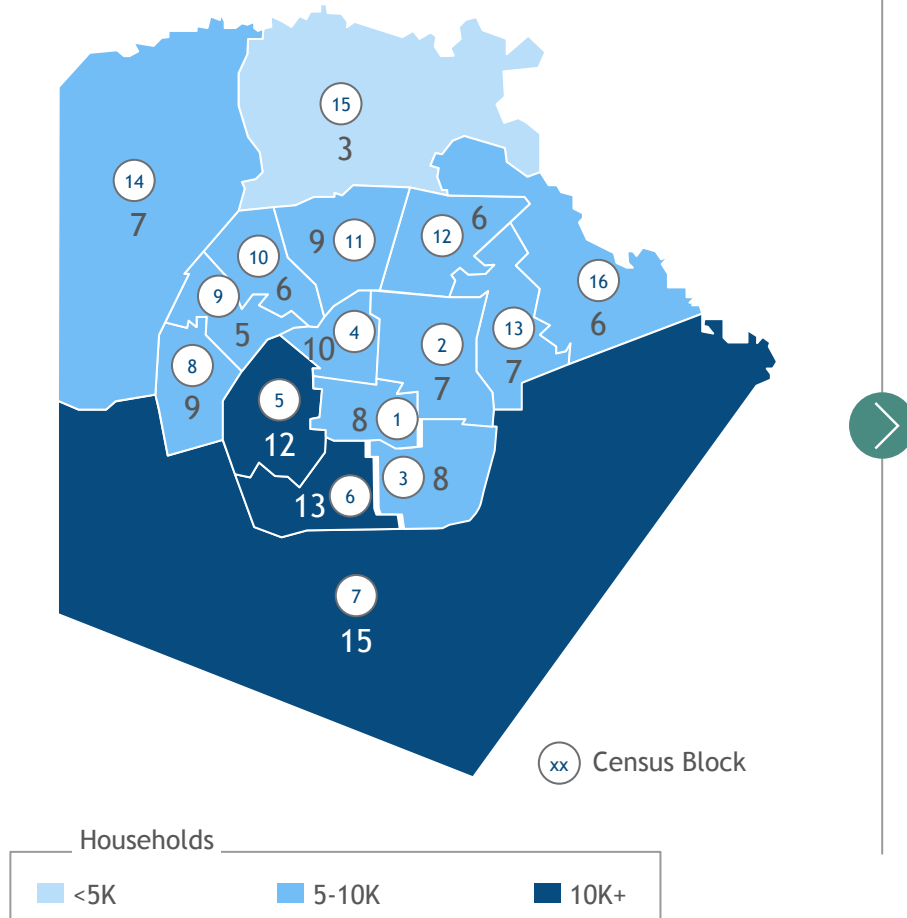

	Households without internet			
Block 1	8K	28%	9K	36%
Block 2	7K	18%	6K	15%
Block 3	8K	25%	9K	26%
Block 4	10K	29%	7K	22%
Block 5	12K	29%	13K	32%
Block 6	13K	29%	14K	31%
Block 7	15K	33%	8K	17%
Block 8	9K	19%	4K	9%
Block 9	5K	12%	3K	7%
Block 10	6K	15%	6K	15%
Block 11	9K	20%	3K	7%
Block 12	6K	16%	3K	10%
Block 13	7K	18%	6K	17%
Block 14	7K	12%	4K	7%
Block 15	3K	8%	<1K	1%
Block 16	6K	15%	3K	7%
County Total (SA+Bexar)	130K	20%	100K	15%

1. Based on Census ACS and SASpeakUp responses of residents reporting that they lack access to the internet Source: SASpeakUp (2019); ACS (2019); BCG analysis

Preliminary

Availability | Households with limited broadband availability by Census block

Households per precinct in 000s¹

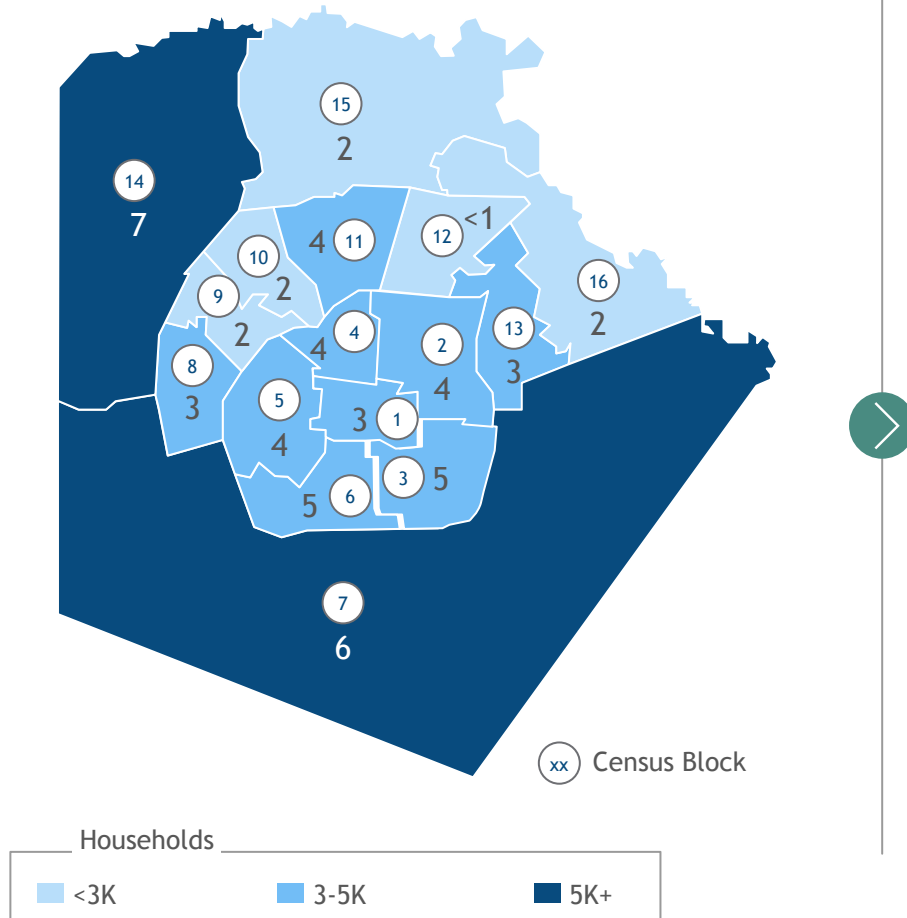

	Households with limited broadband availability		
Block 1	3K	8K	44%
Block 2	4K	7K	64%
Block 3	5K	8K	64%
Block 4	4K	10K	39%
Block 5	4K	12K	32%
Block 6	5K	13K	44%
Block 7	6K	15K	36%
Block 8	3K	9K	32%
Block 9	2K	5K	39%
Block 10	2K	6K	39%
Block 11	4K	9K	50%
Block 12	<1K	6K	<1%
Block 13	3K	7K	36%
Block 14	7K	7K	100%
Block 15	2K	3K	50%
Block 16	2K	6K	36%
County Total (SA+Bexar)	56K	130K	43%

1. Based on Census ACS and SASpeakUp responses reporting slow or unavailable service as residents' primary reason for not using the internet
 Source: ACS (2019); SASpeakUp (2019); BCG analysis

Preliminary

Affordability | Households with limited broadband affordability by Census block

Households per precinct in 000s¹

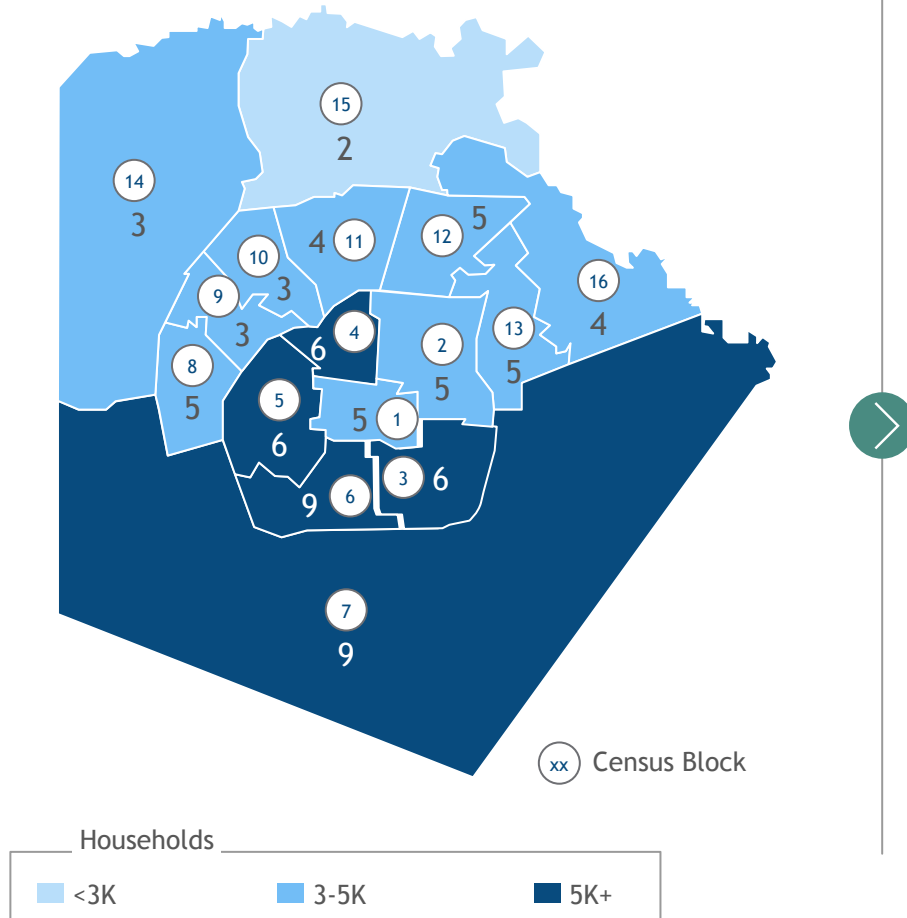

	Households without affordable internet		
Block 1	5K	8K	73%
Block 2	5K	7K	75%
Block 3	6K	8K	75%
Block 4	6K	10K	59%
Block 5	6K	12K	52%
Block 6	9K	13K	73%
Block 7	9K	15K	62%
Block 8	5K	9K	52%
Block 9	3K	5K	59%
Block 10	3K	6K	59%
Block 11	4K	9K	50%
Block 12	5K	6K	80%
Block 13	5K	7K	69%
Block 14	3K	7K	50%
Block 15	2K	3K	50%
Block 16	4K	6K	66%
County Total (SA+Bexar)	82K	130K	63%

1. Based on Census ACS and SASpeakUp responses of residents reporting that high internet plan pricing is their primary reason for not using the internet
 Source: ACS (2019); SASpeakUp (2019); BCG analysis

Next steps

Household need

- Develop process for continuous household surveying and speed tests to stay current on the evolving needs of residents
- Collaborate with Texas A&M on data evaluation and explore opportunities to scale data collection beyond students
- Create feedback channels to continually improve data collection mechanisms

Availability

- Integrate existing city fiber mapping (e.g., Public Works / permitting) into comprehensive fiber map
- Partner with companies specializing in fiber mapping and asset assessment (e.g., ConnectedNation)
- Establish ownership of comprehensive mapping data sourced from city and service providers



Thank You