



Modeling global ocean biogeochemistry in support of field and satellite missions

Cecile S. Rousseaux

*Universities Space Research Association
NASA Global Modeling and Assimilation Office*

NOAA Ocean Color Coordinating Group (NOCCG) March 24th, 2021



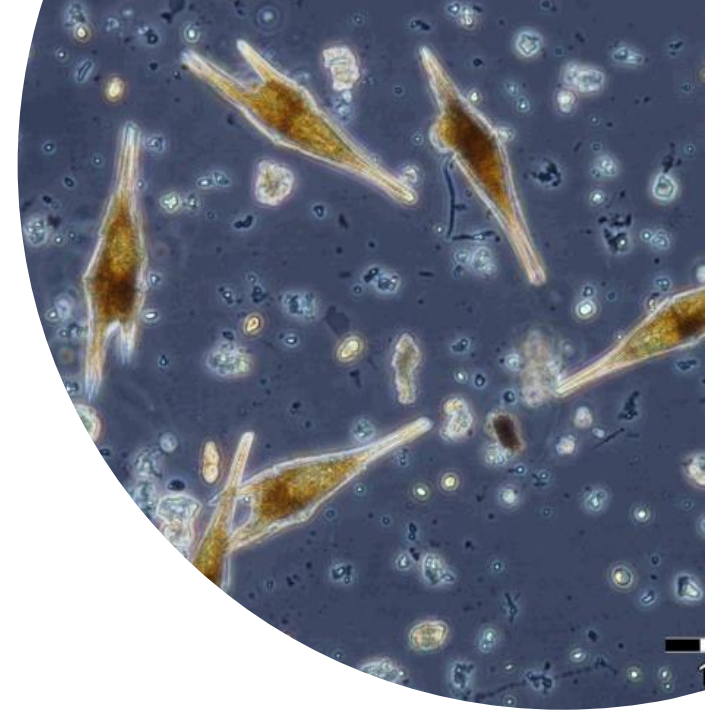
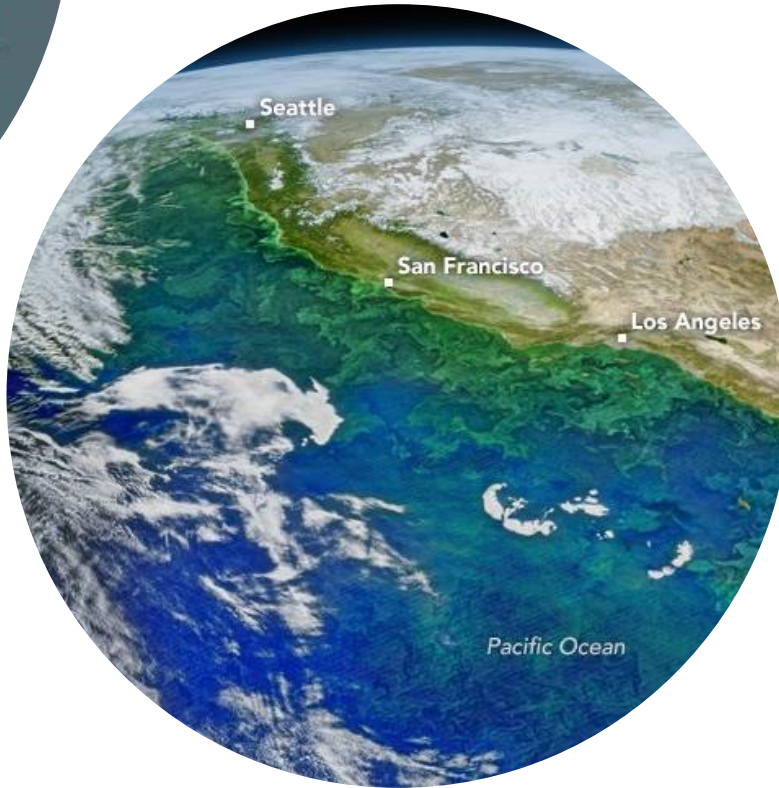
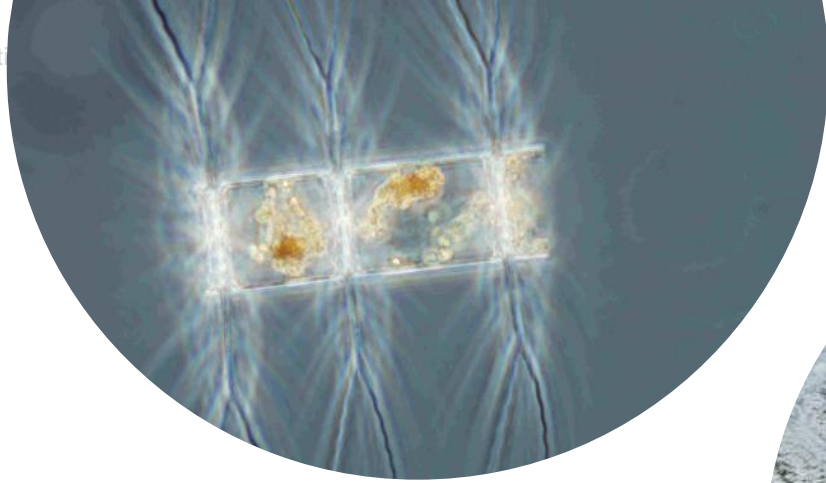

Why do we care?



The NASA Ocean Biogeochemical Model (NOBM)

- Global
- 2/3x1.25 degrees (Poseidon) or 1 degree (MOM)
- Forced by Reanalysis products (winds, humidity, shortwave, longwave radiation, etc) and satellite data (aerosols and clouds)
- Assimilates chlorophyll, absorption of Colored Dissolved Organic Matter and Particulate Inorganic Carbon (SeaWiFS, MODIS-Aqua, VIIRS)
- Used for climate research (e.g., trend analysis, El Niño effects), instrument development (e.g., PACE), field sampling design (e.g., EXPORTS) and seasonal ocean biogeochemical forecast (NASA Modeling, Analysis, and Prediction Project)

The NASA Ocean Biogeochemical Model (NOBM)

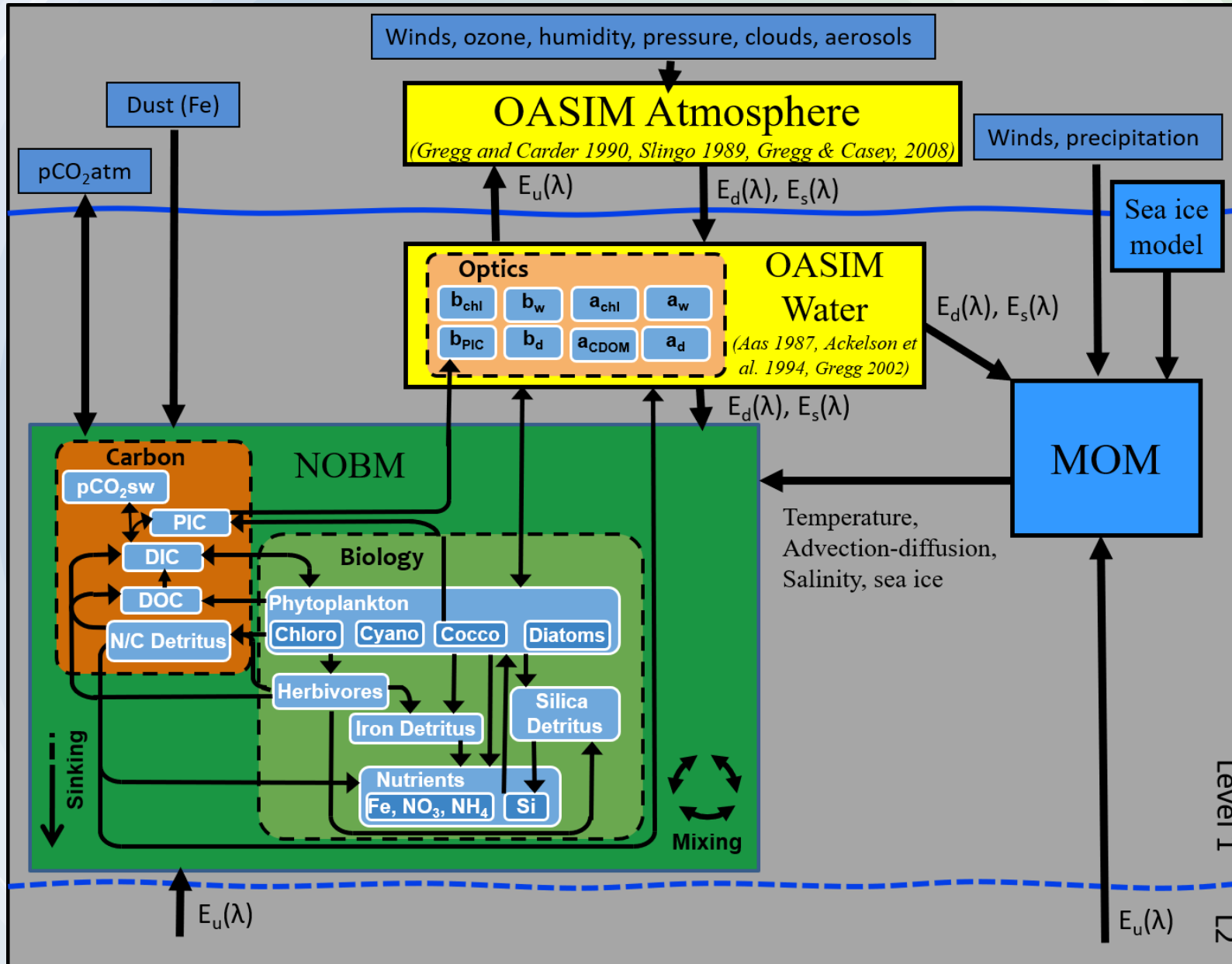

Plankton, Aerosol, Cloud, ocean Ecosystem (PACE)

- PACE: first global hyperspectral ocean color mission. Focused on global ecosystem structure, physics, health, & carbon dynamics to resolve reasons & consequences of change in today's oceans & atmospheres to predict and prepare for tomorrow's Earth
- Mission to launch in ~2022-2023
- Hyperspectral ocean color instrument (350-800, 5nm)
- Two polarimeters
- 1-km² ground sample distance at nadir
- Monthly lunar calibration of all science detectors
- ± 20-deg tilt to avoid sun glint
- 2-day global coverage

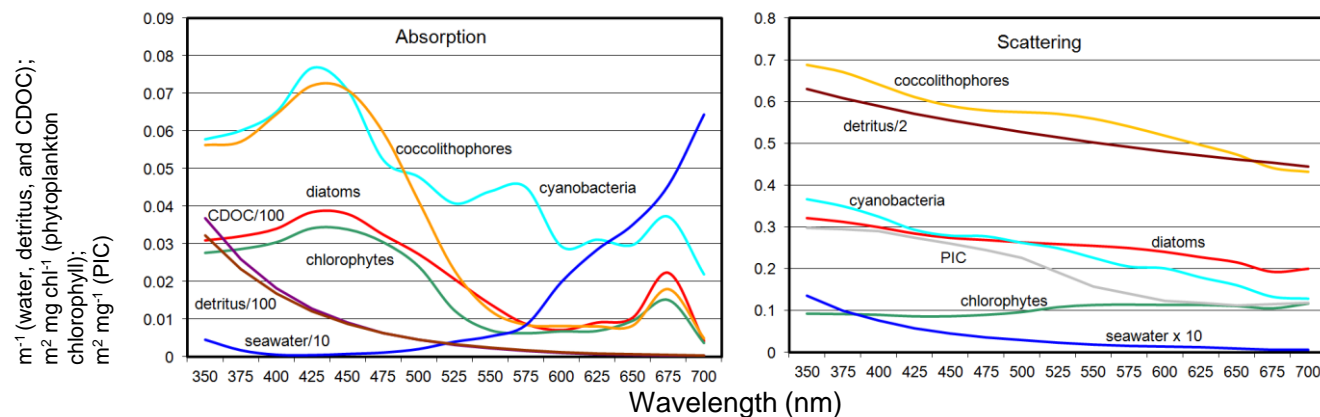

Rousseaux, C.S. (PI) "Phytoplankton Composition algorithms for PACE".

PACE Science Team (NNH13ZDA001N-PACEST), Grant # NNX15AE81G, 2015-2019;

Rousseaux, C.S. (PI) "Phytoplankton Algorithms and Data Assimilation: Preparing a Pre-launch Path to Exploit PACE Spectral Data".

PACE Science Team (NNH19ZDA001N-PACESAT), Grant # 80NSSC20M0208, 2020-2023

- Objectives of our proposals:
 1. Develop relationships between water leaving radiances and phytoplankton community composition using a radiation model, in situ data, and an established global biogeochemical model
 2. Develop a framework to assimilate hyperspectral water leaving radiance in a global Earth System Model

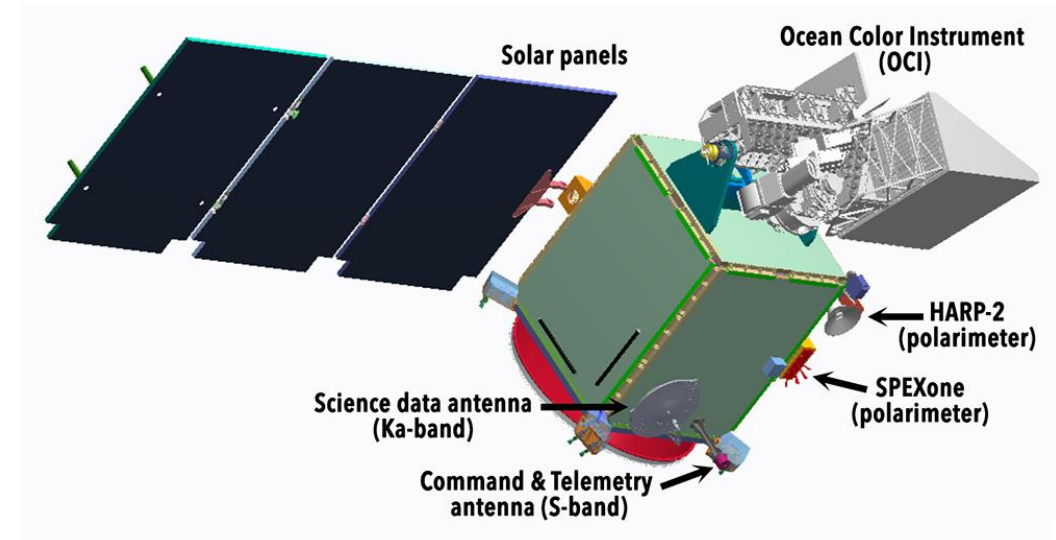
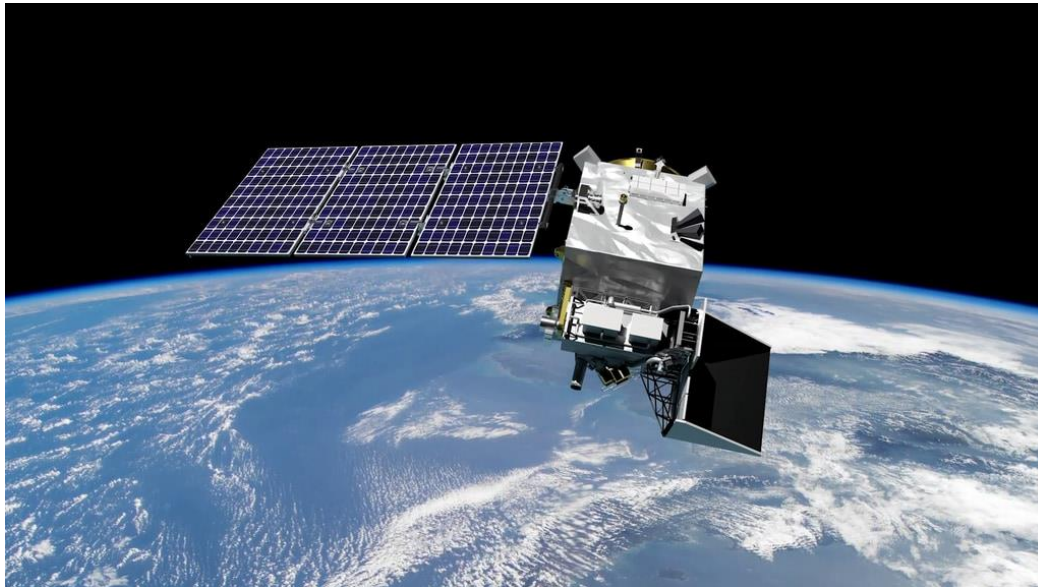

Objective 1: Develop relationships between water leaving radiances and phytoplankton community composition using a radiation model, in situ data, and an established global biogeochemical model

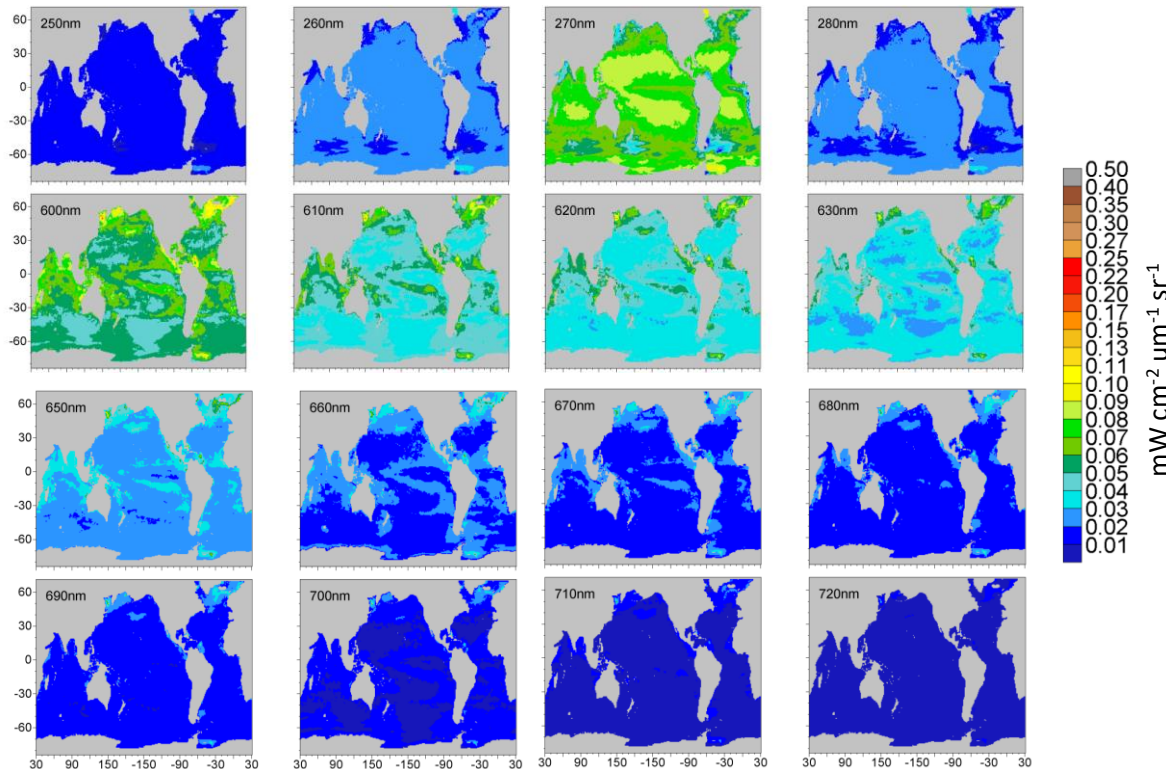

- Produced a 1-nm upwelling radiance data set using the NASA Ocean Biogeochemical Model and the Ocean-Atmosphere Spectral Irradiance Model (OASIM)-PACE simulated dataset

Model normalized water-leaving radiances for selected wavelengths in the ultraviolet, long visible, and near-infrared region.

- Gregg W.W. and Rousseaux C.S. 2017. Simulating PACE Ocean Global Radiances. *Frontiers in Marine Science*, doi: 10.3389/fmars.2017.00060
- Gregg W.W. and Rousseaux C.S. 2016. Directional and Spectral Irradiance in Ocean Models: Effects on Simulated Global Phytoplankton, Nutrients, and Primary Production. *Frontiers in Marine Science*, doi: 10.3389/fmars.2016.00240

- This simulated dataset was validated against existing multispectral ocean color satellite data

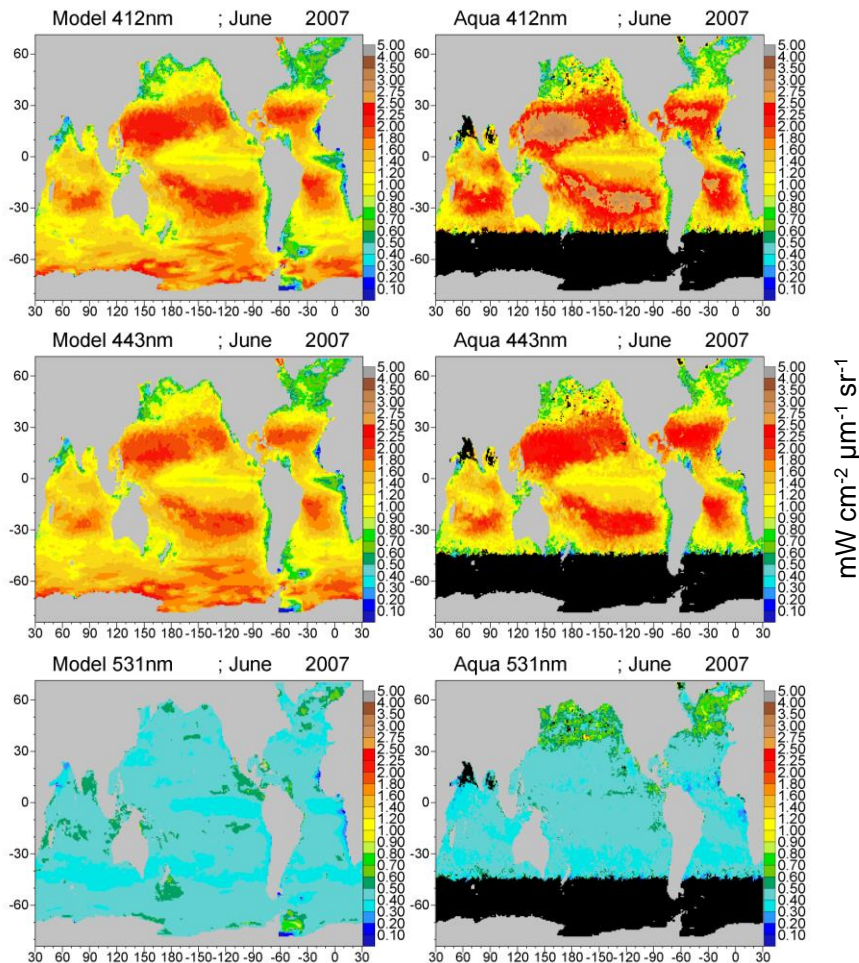

Model normalized water-leaving radiances $L_w N(\lambda)$ for 412nm and 443nm compared to MODIS-Aqua radiances.

	Median	Difference	Diff %	SIQR	r	N
412	1.428	-0.106	-7.4%	0.163	0.950	420498
443	1.403	0.008	0.6%	0.107	0.936	420615
488	1.100	-0.046	-4.2%	0.081	0.827	420664
531	0.416	-0.033	-7.9%	0.055	0.459	420664

The simulated dataset was used in several applications. For example:

- Test the effects that spectral and directional light have in simulations of ocean radiative transfer model ([Gregg and Rousseaux 2016](#)).
- Develop a test granule simulation to use for algorithm development and other post-processing efforts by the PACE Project Team (GMAO and PACE Project collaboration-POC: Patricia Castellanos).

- Develop relationships between water leaving radiances and phytoplankton community composition
 1. Use OASIM to generate water leaving radiances for individual and assemblages of phytoplankton functional groups, as well as other optically active constituents (water, detrital material, CDOM, and particulate inorganic carbon)
 2. Spectral analyses including band ratios, derivative analysis and clustering techniques (Lin et al. 2013; Torrecilla et al. 2011; Xi et al. 2017).
 3. Test the ability of the algorithms to derive phytoplankton concentration and composition in a natural environment at the global scale
 4. Use in situ data withheld from algorithm development to derive bias and uncertainties

Objective 2: Develop a framework to assimilate hyperspectral water leaving radiance in a global Earth System Model

- Use the Joint Effort for Data assimilation Initiative (JEDI), a framework that allows for the assimilation of a variety of variables within GEOS-NOBM
- JEDI: Joint Center for Satellite Data Assimilation (JCSDA, NOAA/NASA) project, aim to provide a unified data assimilation framework for research and operational use for different components of the Earth system and various applications
- Compare the model output from a run assimilating multi-spectral data products (chlorophyll, PIC and aCDOM) with the model output from a model run that assimilates hyperspectral water leaving radiances
- Produce Level-4 products of existing data product or new product if algorithm not currently available

Assimilated VIIRS Chlorophyll Sep 1 2013

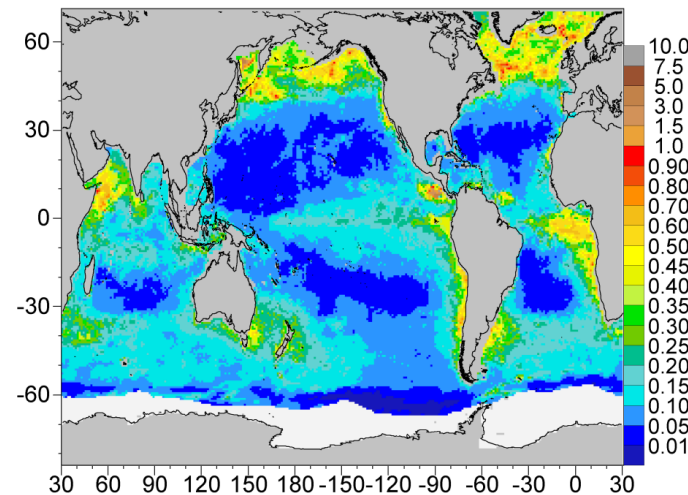

Ice fields are shown in white.

Daily VIIRS Chlorophyll Sep 1 2013

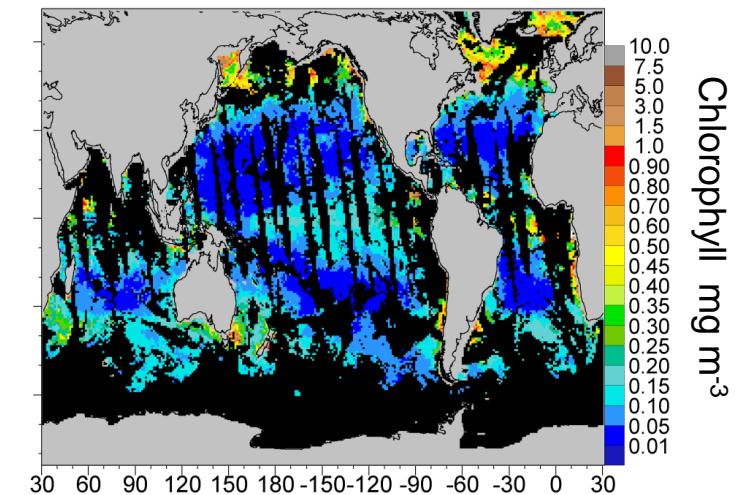

Missing data is shown in black.

Seasonal Forecast of Ocean Biogeochemistry

Rousseaux C.S. (PI) "Seasonal Forecast of Ocean Biogeochemistry". NASA Modeling, Analysis, and Prediction Program (NNH16ZDA001N-MAP), Proposal # 80NSSC17K0268, 2017-2021

1997-98 El Niño

Motivation

- Forecasting recruitment of lower trophic levels (currently using temperature and currents for example)
- Forecasting effects of climate variability on lower trophic levels
 - ✓ Strategic rather than reactive marine resource management
- Phytoplankton directly affect heat content through the absorption of light
 - ✓ Improved forecast of ocean heat balances and atmospheric events that depends on heat balance
- Phytoplankton directly influence carbon fluxes with the atmosphere
 - ✓ Improved skills of future carbon estimates

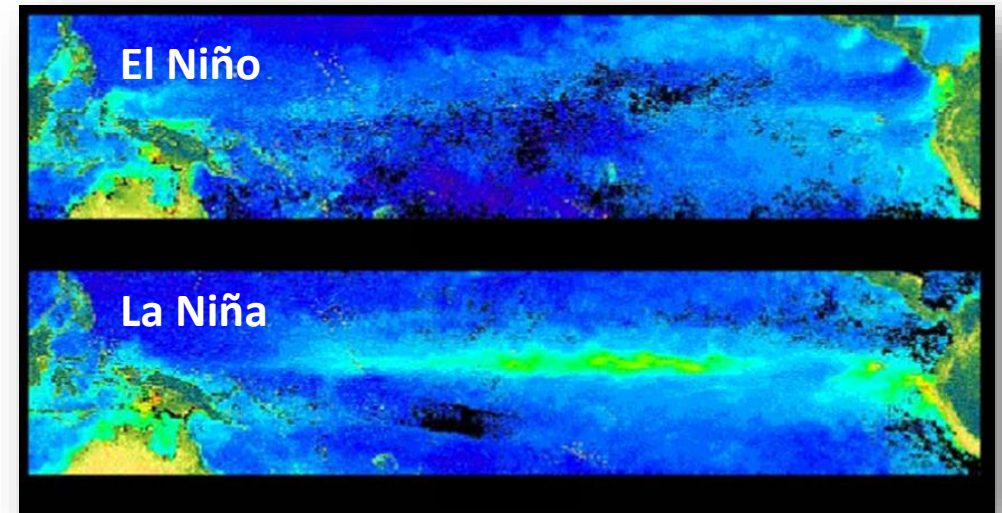
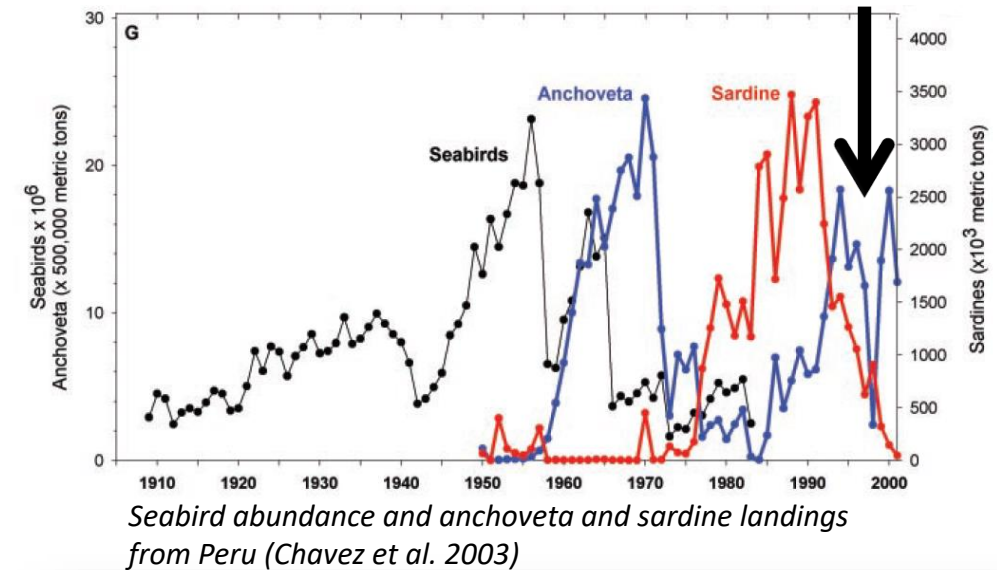

Approach

- NASA Ocean Biogeochemical Model
- GMAO sub-seasonal to seasonal forecast (Molod et al. 2020)
- Initial conditions produced using satellite ocean color assimilation and forcing by MERRA-2
- Assess skills of 51 retrospective forecasts of chlorophyll from February 2012 until December 2016 in 12 major oceanographic regions

NASA Ocean Biogeochemical Model (NOBM)

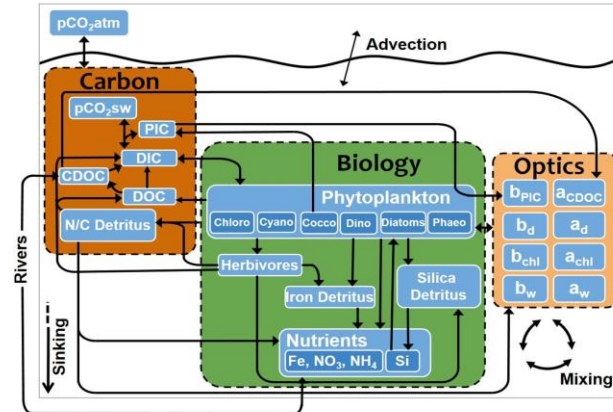

+Assimilation of Suomi-National Polar-orbiting Partnership ocean color data
 + NASA Global Modeling and Assimilation Office Subseasonal to Seasonal forecast forcing data

9-month forecast of chlorophyll concentration

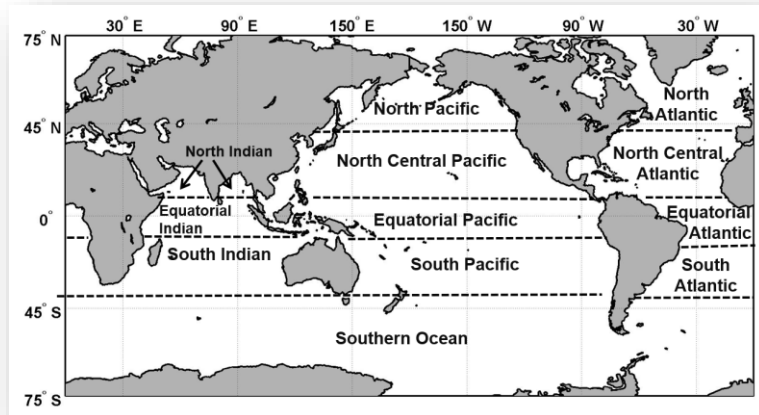
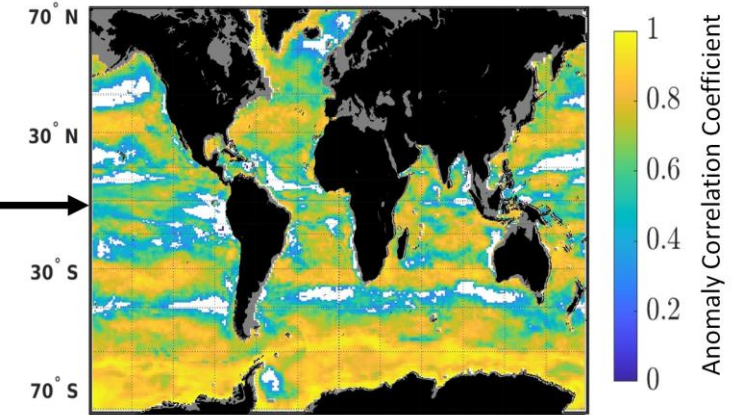

System Performance	Free run	MERRA-2	No
	Assimilation run	MERRA-2	Yes
Forecast initial conditions	Assimilation run	MERRA-2	Yes
Forecasts	Free run	GMAO-S2S forecast	No

Rousseaux, C.S., Gregg, W.W., Ott, L. 2021. Assessing the skills of a seasonal forecast of chlorophyll in the global pelagic oceans. *Remote Sensing*, 2021, 13(6), 1051; <https://doi.org/10.3390/rs13061051>

Rousseaux, C. S., and W. W. Gregg (2017), Forecasting Ocean Chlorophyll in the Equatorial Pacific, *Frontiers in Marine Science*, 4(236).

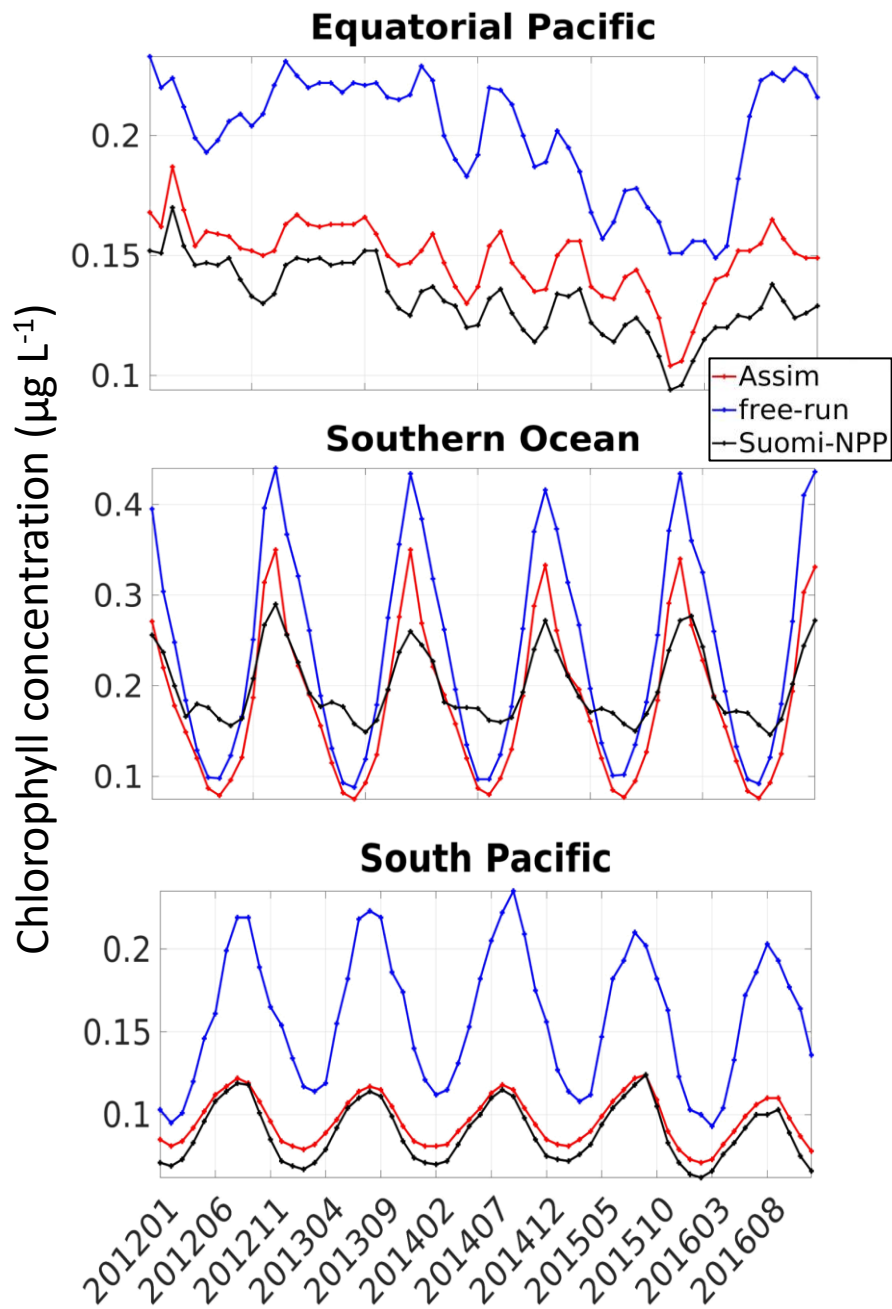

System performance

- Chlorophyll concentration from free-run significantly correlated to those from Suomi-NPP in all regions except the North Indian
- Assimilation decreases uncertainties in all regions
- Overall ability of the free-run to simulate the right seasonal and interannual cycle but not always the right magnitude

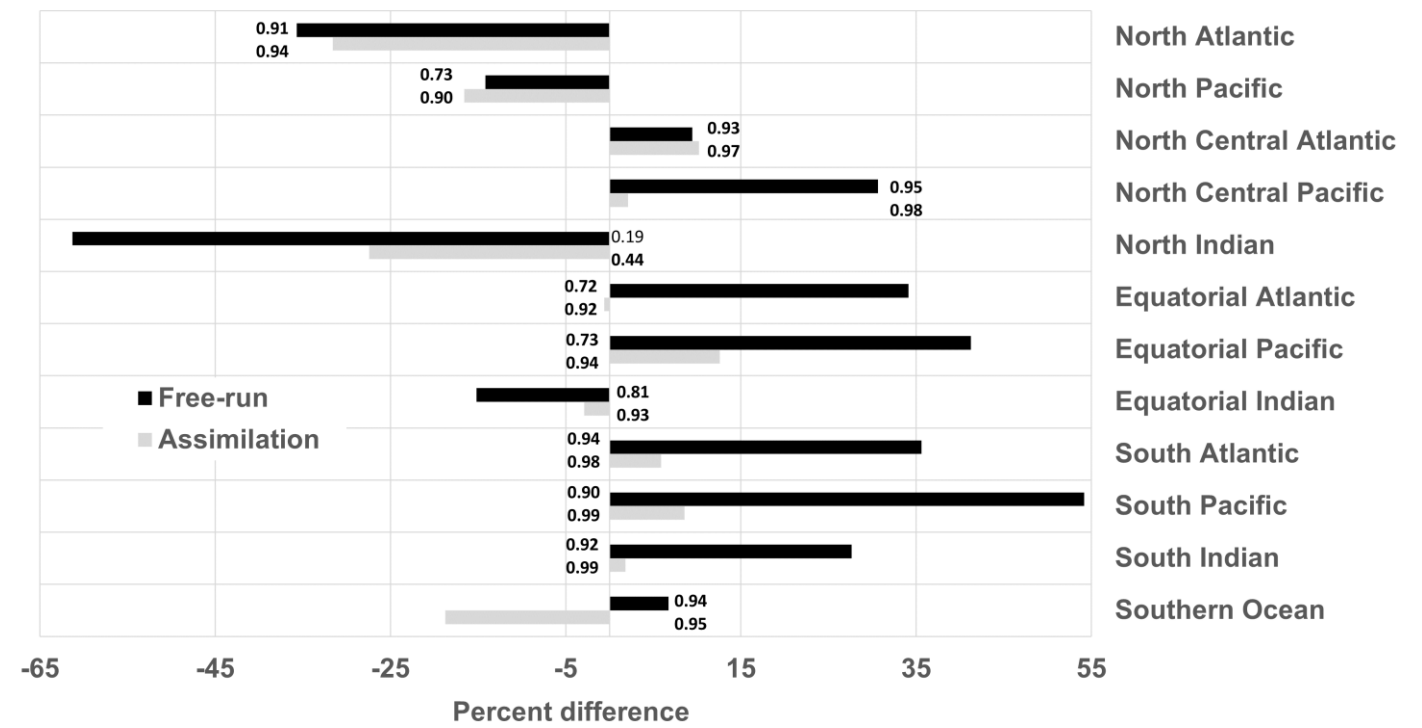

- Significant ACCs for the majority of regions and lead months
- ACC decrease significantly with lead month but remains significant
- Bias in the system impacts the skills of the forecast (note bias do exist in satellite data)
- If ACC with seasonal cycle removed, ACC still higher for forecast than for a persistence simulation.

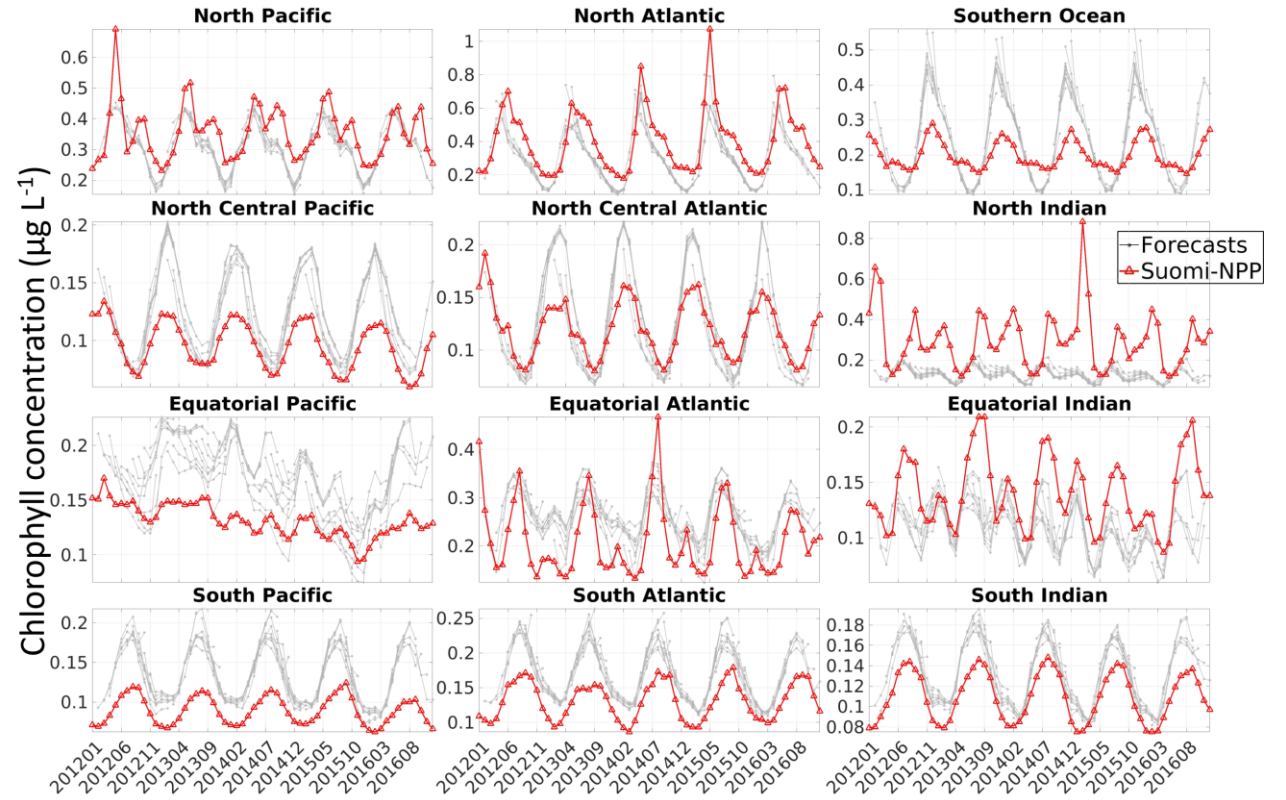

Rousseaux, C.S., Gregg, W.W., Ott, L. 2021. Assessing the skills of a seasonal forecast of chlorophyll in the global pelagic oceans. *Remote Sensing*, 2021, 13(6), 1051; <https://doi.org/10.3390/rs13061051>

Anomaly Correlation Coefficient for Lead 1-month forecast

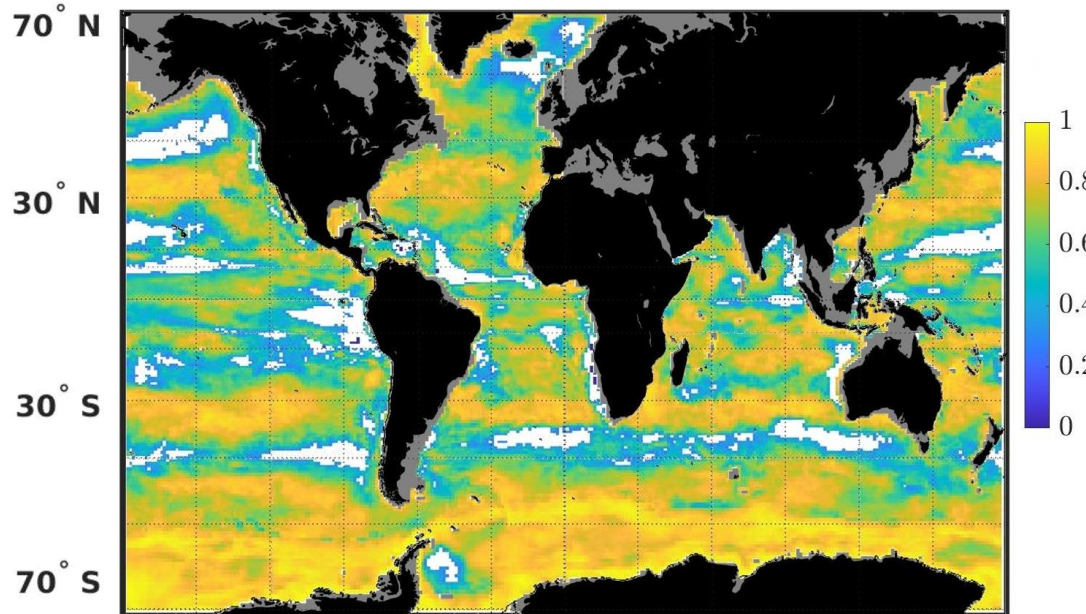

Percent difference with Suomi- NPP for Lead 1-month forecast

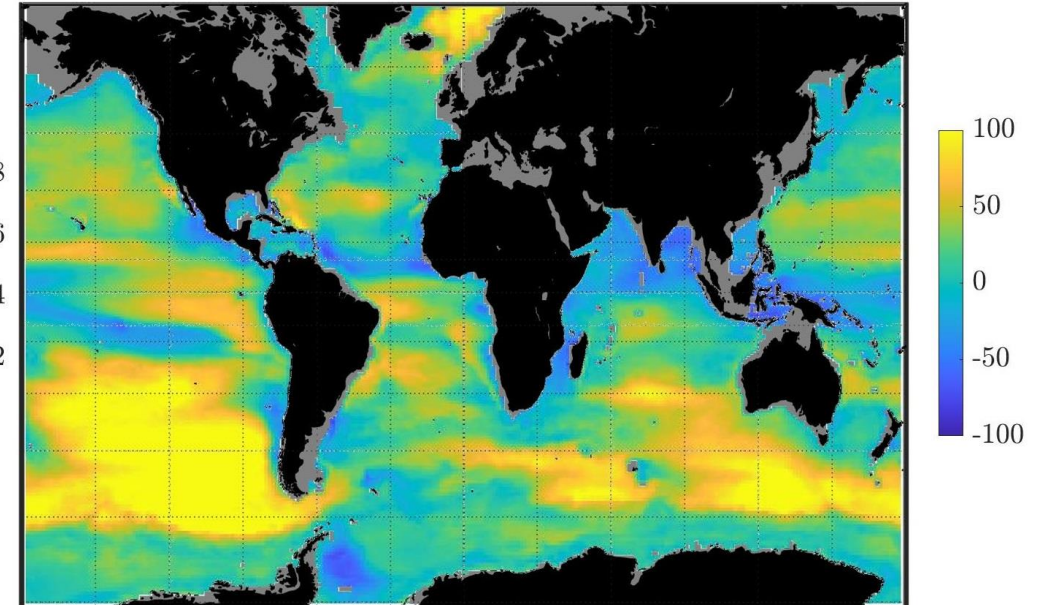

- Results suggests the potential for skillful global biogeochemical forecasts on seasonal timescales of chlorophyll, primary production and harmful algal blooms that could support fisheries management and other applications.

Rousseaux, C.S., Gregg, W.W., Ott, L. 2021. Assessing the skills of a seasonal forecast of chlorophyll in the global pelagic oceans. Remote Sensing, 2021, 13(6), 1051; <https://doi.org/10.3390/rs13061051>

Export Processes in the Ocean from RemoTe Sensing (EXPORTS)

Rousseaux C.S. (PI) "Observation-System Simulation Experiments (OSSEs) and seasonal forecasts to support EXPORTS". Ocean Biology and Biogeochemistry (NNH15ZDA01N-OBB), Proposal # 15-OBB15-0004, 2017-2021

- NASA Multi-platform Program to understand how much photosynthetically–produced carbon in the surface oceans is transported to the deep ocean.
- Support of field campaign by:
 - (1) Providing overview of biogeochemical conditions using hindcasts
 - (2) Provide updated forecast in the months leading up to field sampling

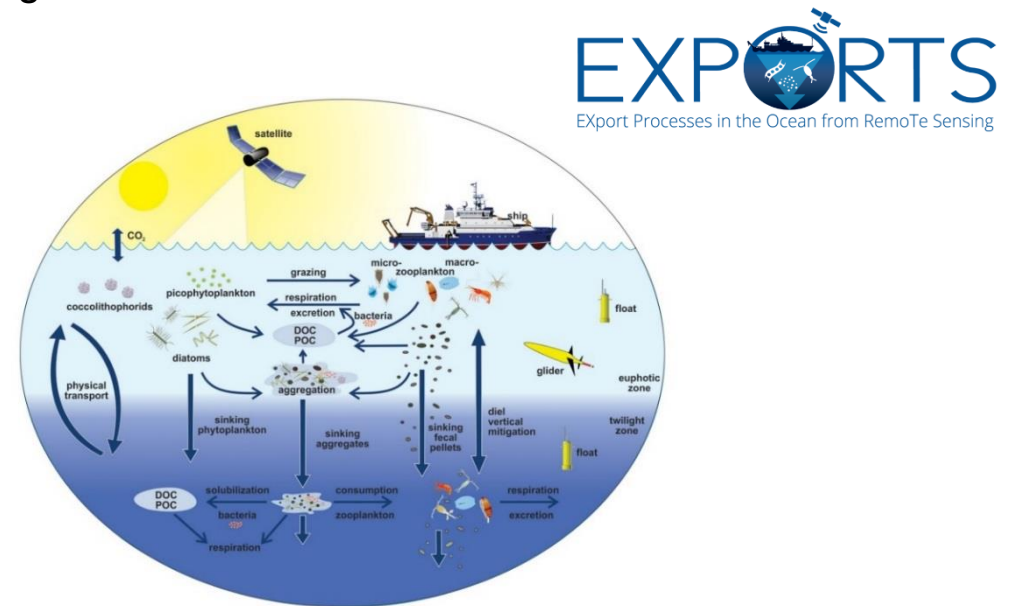
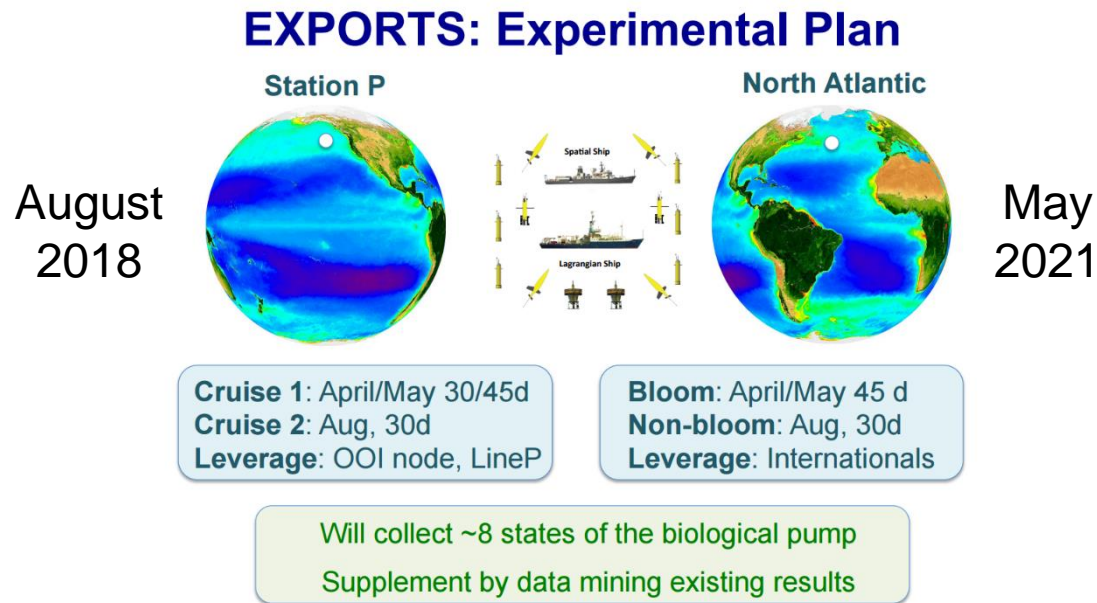

FIGURE 1 | The EXPORTS conceptual diagram illustrates the links among the ocean's biological pump and pelagic food web and our ability to sample these components from ships, satellites, and autonomous vehicles. Light blue waters are the euphotic zone (E₂), while the darker blue waters represent the twilight zone (T₂). Figure is adapted from Steinberg (in prep.) and the U.S. Joint Global Ocean Flux Study (JGOFS) (http://usjgofs.whoi.edu/images/biological_pump.tif).

Wrapping up...

The use of global ocean biogeochemical models have many potential applications including:

- Preparing for satellite and field campaigns (e.g., EXPORTS, PACE)
- Producing sensitivity analysis and simulated data (e.g., PACE)
- Tackling research questions such as the effects of climate variability on ocean biogeochemistry
- The assimilation of satellite ocean color provides global coverage as well as products that are currently not available through remote sensing alone
- Potential for skillful global biogeochemical seasonal forecasts of chlorophyll, primary production and harmful algal blooms that could support fisheries management and other applications.
- In forecasting systems, the assimilation of satellite ocean color can also improve those initial conditions that have been shown to be critical in improving the skills of the forecasting system
- The new era of hyperspectral data will open the door to a series of applications and challenges.